

DATE	DESCRIPTION	REV.
9.17.04	CHANGE AS PER ECN 04-104	F
8.15.11	ECN 11-106; ADD FLATNESS	G

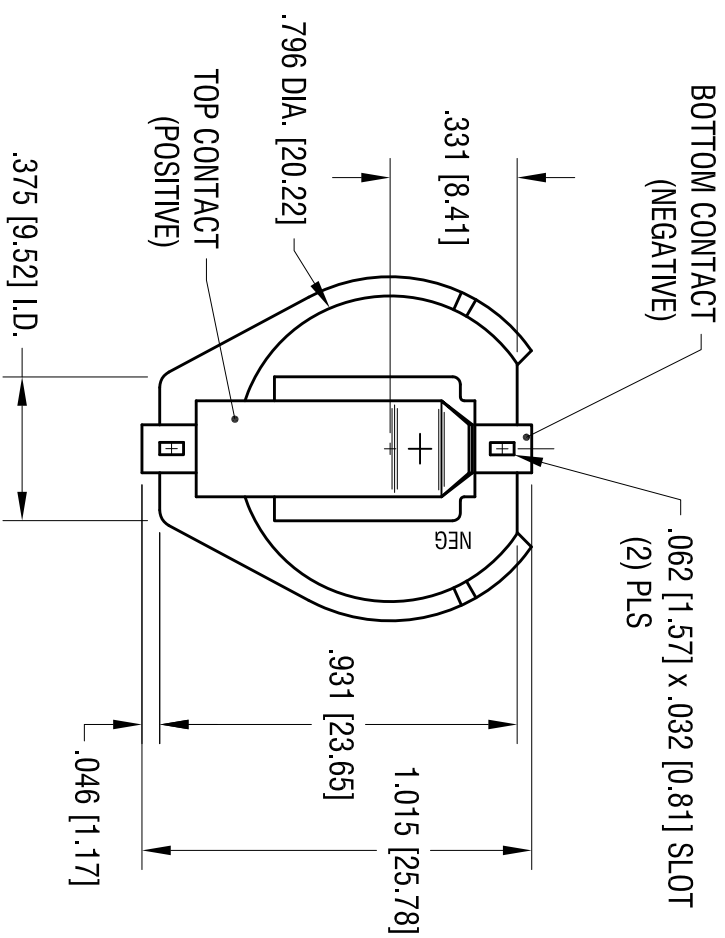

- NOTES:
1. BASE:
MAT'L - HIGH TEMPERATURE NYLON (UL 94V-0)
COLOR BLACK
 2. CONTACTS (TOP AND BOTTOM):
MAT'L - .015 [0.38] THK SPRING STEEL
FINISH: TIN NICKEL PLATE

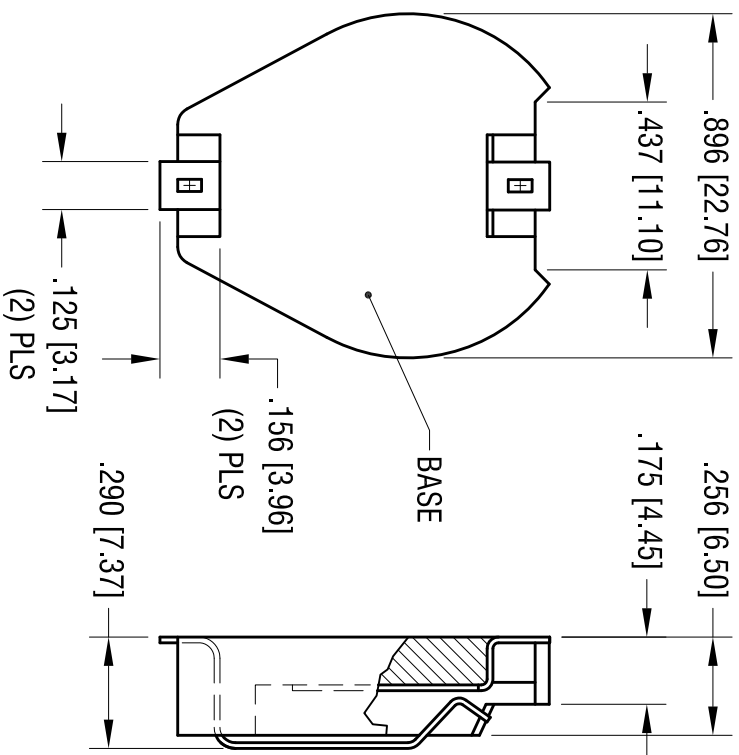
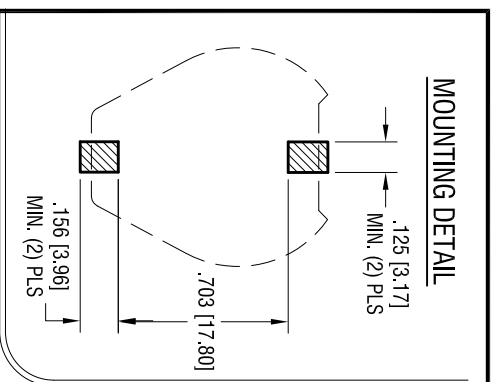
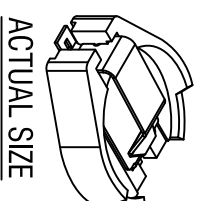

THIS DOCUMENT IS THE PROPERTY OF KEYSTONE ELECTRONICS CORP. AND SHALL NOT BE REPRODUCED, DISTRIBUTED OR USED AS A BASIS FOR MANUFACTURE WITHOUT PRIOR WRITTEN PERMISSION FROM KEYSTONE ELECTRONICS CORP.

KEYSTONE ELECTRONICS CORP.

www.keystec.com • ASTORIA, N.Y. 11105-2017 • Tel (718) 956-8900

PART NAME

20mm BATTERY HOLDER, SMT

MATERIAL

AS NOTED

FINISH

AS NOTED

TOLERANCES	INCH	[MM]	CODE	DRN BY	DATE
DECIMAL	± .010	[± 0.25]	C	BOONE	12.14.92
ANGULAR	± 1°			LN	SCALE 2X
				App'd	DWG NO. 1061