

Introduction

Lattice has extended its family of high-speed serial backplane devices with the ORSO42G5 and ORSO82G5 devices. Built on the Series 4 reconfigurable embedded System-on-a-Chip (SoC) architecture, the ORSO42G5 and ORSO82G5 are high-speed transceivers with aggregate bandwidths of over 10 Gbps and 20 Gbps respectively. These devices are targeted toward users needing high-speed backplane interfaces for SONET and other non-SONET applications. The ORSO42G5 has four channels and the ORSO82G5 has eight channels of integrated 0.6-2.7Gbps SERDES channels with built-in Clock and Data Recovery (CDR), along with more than 400K usable FPGA system gates. The CDR circuitry, available from Lattice’s high-speed I/O portfolio (sysHSI™), has already been used in numerous applications to create STS-48/STM-16 and STS-192/STM-64 SONET/SDH interfaces. With the addition of protocol and access logic, such as framers and Packet-over-SONET (PoS) interfaces, designers can build a configurable interface using proven backplane driver/receiver technology. Designers can also use the device to drive high-speed data transfer across buses within a system that are not SONET/SDH based. The ORSO42G5 and ORSO82G5 can also be used to provide a full 10 Gbps backplane data connection and, with the ORSO82G5, support both work and protection connections between a line card and switch fabric.

The ORSO42G5 and ORSO82G5 support a clockless high-speed interface for interdevice communication on a board or across a backplane. The built-in clock recovery of the ORSO42G5 and ORSO82G5 allows higher system performance, easier-to-design clock domains in a multiboard system and fewer signals on the backplane. Network designers will benefit from using the backplane transceiver as a network termination device. Sister devices, the ORT42G5 and the ORT82G5, support 8b/10b encoding/decoding and link state machines for 10 Gbit Ethernet (XAUI) and Fibre Channel. The ORSO42G5 and ORSO82G5 perform SONET data scrambling/descrambling, streamlined SONET framing, limited Transport OverHead (TOH) handling, plus the programmable logic to terminate the network into proprietary systems. The cell processing feature in the ORSO42G5 and ORSO82G5 makes them ideal for interfacing devices with any proprietary data format across a high-speed backplane. For non-SONET applications, all SONET functionality is hidden from the user and no prior networking knowledge is required. The ORSO42G5 and ORSO82G5 are completely pin-compatible with the ORT42G5 and ORT82G5 devices.

Table 1. ORCA ORSO42G5 and ORSO82G5 Family – Available FPGA Logic

| Device | PFU Rows | PFU Columns | Total PFUs | FPGA Max User I/O | LUTs | EBR Blocks ² | EBR Bits (K) | FPGA System Gates (K) ¹ |
|----------|----------|-------------|------------|-------------------|--------|-------------------------|--------------|------------------------------------|
| ORSO42G5 | 36 | 36 | 1296 | 204 | 10,368 | 12 | 111 | 333-643 |
| ORSO82G5 | 36 | 36 | 1296 | 372 | 10,368 | 12 | 111 | 333-643 |

1. The embedded core, Embedded System Bus, FPGA interface and MPI are not included in the above gate counts. The System Gate ranges are derived from the following: Minimum System Gates assumes 100% of the PFUs are used for logic only (No PFU RAM) with 40% EBR usage and 2 PLLs. Maximum System Gates assumes 80% of the PFUs are for logic, 20% are used for PFU RAM, with 80% EBR usage and 4 PLLs.
2. There are two 4K x 36 (144K bits each) RAM blocks in the embedded core which are also accessible by the FPGA logic.

Table of Contents

| | | | |
|---|----|--|-----|
| Introduction | 1 | Sample Initialization Sequences – ORSO82G5 | 70 |
| Table of Contents | 2 | Reset Conditions | 72 |
| Embedded Function Features | 3 | SERDES Characterization Test Mode (ORSO82G5 Only) | 73 |
| Programmable Features | 4 | Embedded Core Block RAM | 74 |
| Programmable Logic System Features | 5 | Register Maps | 76 |
| Description | 6 | Types of Registers | 77 |
| What Is an FPSC? | 6 | Absolute Maximum Ratings | 108 |
| FPSC Overview | 6 | Recommended Operating Conditions | 108 |
| FPSC Gate Counting | 6 | SERDES Electrical and Timing Characteristics | 108 |
| FPGA/Embedded Core Interface | 6 | High Speed Data Transmitter | 109 |
| ispLEVER Development System | 7 | High Speed Data Receiver | 110 |
| FPSC Design Kit | 7 | External Reference Clock | 112 |
| ORSO82G5/42G5 FPGA Logic Overview | 7 | Pin Descriptions | 113 |
| ORCA Series 4 FPGA Logic Overview | 7 | Power Supplies | 118 |
| PLC Logic | 8 | Power Supply Descriptions | 118 |
| Programmable I/O | 8 | Recommended Power Supply Connections | 118 |
| Routing | 9 | Recommended Power Supply Filtering Scheme | 118 |
| System Level Features | 9 | Package Information | 120 |
| MicroProcessor Interface | 9 | Package Pinouts | 120 |
| System Bus | 9 | Package Thermal Characteristics Summary | 148 |
| Phase-Locked Loops | 9 | θ_{JA} | 148 |
| Embedded Block RAM | 10 | Ψ_{JC} | 148 |
| Configuration | 10 | θ_{JC} | 148 |
| ORSO42G5 and ORSO82G5 Overview | 10 | θ_{JB} | 148 |
| Embedded Core Overview | 11 | FPSC Maximum Junction Temperature | 149 |
| ORSO42G5 and ORSO82G5 Main Operating Modes - Overview | 12 | Package Thermal Characteristics | 149 |
| Embedded Core Functional Blocks - Overview | 13 | Heat Sink Vendors for BGA Packages | 149 |
| Loopback - Overview | 14 | Package Parasitics | 149 |
| FPSC Configuration - Overview | 15 | Package Outline Drawings | 150 |
| ORSO42G5 and ORSO82G5 Embedded Core | | Part Number Description | 151 |
| Detailed Description | 16 | Device Type Options | 151 |
| Top Level Description - Transmitter (TX) and Receiver (RX) Architectures | 16 | Ordering Information | 151 |
| Detailed Description - SERDES Only Mode | 19 | Conventional Packaging | 151 |
| 32:8 MUX | 21 | Lead-Free Packaging | 152 |
| SONET Mode Operation – Detailed Description | 24 | | |
| SONET Mode Transmit Path | 30 | | |
| SONET Mode Receive Path | 33 | | |
| Cell Mode Detailed Description | 49 | | |
| Cell Mode Transmit Path | 52 | | |
| Cell Mode Receive Path | 56 | | |
| Cell Extractor | 56 | | |
| Receive FIFO | 57 | | |
| Input Port Controllers | 57 | | |
| IPC Receive Cell Mode Timing Core/FPGA | 59 | | |
| Reference Clock Requirements | 67 | | |
| Sample Initialization Sequences – ORSO42G5 | 69 | | |

Embedded Function Features

- High-speed SERDES programmable serial data rates of 0.6 Gbps to 2.7 Gbps.
 - Asynchronous operation per receive channel (separate PLL per channel).
 - Transmit pre-emphasis (programmable) for improved receive data eye opening.
 - Provides a 10 Gbps backplane interface to switch fabric using four work and, with the ORSO82G5, four protect 2.5 Gbit/s links. Also supports port cards at rates between 0.6 Gbps and 2.7 Gbps.
 - Allows wide range of applications for SONET network termination, as well as generic data moving for high-speed backplane data transfer.
 - No knowledge of SONET/SDH needed in generic applications. Simply supply data (75 MHz-168.75 MHz clock) and at least a single frame pulse.
 - High-Speed Interface (HSI) function for clock/data recovery serial backplane data transfer without external clocks.
 - Four- or eight-channel HSI functions provide 2.7 Gbps serial user data interface per channel for a total chip bandwidth of >10Gbps or >20 Gbps (full duplex).
 - SERDES has low-power CML buffers and support for 1.5V/1.8V I/Os.
 - SERDES HSI automatically recovers from loss-of-clock once its reference clock returns to normal operating state.
 - Powerdown option of SERDES HSI receiver and/or transmitter on a per-channel basis.
 - Ability to mix half-rate and full-rate between the channels with the same reference clock.
 - Ability to configure each SERDES block independently with its own reference clock.
 - STS-48 framing in SONET mode.
 - Programmable enable of SONET scrambler/descrambler, A1/A2 insertion and B1 generation and checking.
 - Insertion and checking of link assignment values to facilitate interconnection and debugging of backplanes.
 - Optional AIS-L insertion during loss-of-frame.
 - Optional RDI-L insertion to indicate remote far-end defects for maintenance capabilities.
 - SPE signal marks payload bytes in SONET mode.
 - Frame alignment across multiple ORSO42G5 and ORSO82G5 devices for work/protect switching at STS-768/STM-256 and above rates.
 - Supports transparent mode where Transport OverHead (TOH) bytes are user-generated in the FPGA.
 - Supports two modes of in-band management and configuration with TOH byte extraction/insertion by the Embedded core. A1/A2 and B1 insertion can be independently enabled.
 - AUTO_SOH where the embedded core inserts the A1/A2 framing bytes, performs the B1 calculation and inserts the B1 byte. All other bytes are passed through unchanged from the FPGA logic as in transparent mode.
 - AUTO_TOH where all of the overhead bytes are set by the embedded core. Most of the bytes are set to zero. At the receive side, all of the TOH bytes except those set to a non-zero value can be ignored.
 - Optional A1/A2 corruption, B1 byte corruption, and K2 byte corruption for system debug purposes.
 - Built-in boundary scan (*IEEE*® 1149.1 and 1149.2 JTAG), including the SERDES interface.
 - FIFOs align incoming data across all eight channels (ORSO82G5 only), groups of four channels, or groups of two channels. Optional ability to bypass alignment FIFOs for asynchronous operation between channels is also provided. (Each channel includes its own recovered clock and frame pulse).
-

-
- Optional cell processing blocks included. Cell processing includes cell creation, extraction, idle cell insertion and deletion asynchronous from line rates. Four cell sizes supported:
 - 77 bytes per cell (75 bytes of data payload)
 - 81 bytes per cell (79 bytes of data payload)
 - 85 bytes per cell (83 bytes of data payload)
 - 93 bytes per cell (91 bytes of data payload)
 - Automatic cell striping across either pairs of SERDES links or, for the ORSO82G5, all eight SERDES links.
 - Addition of two 4K X 36 dual-port RAMs accessible by the programmable logic.

Programmable Features

- High-performance programmable logic:
 - 0.16 μm 7-level metal technology.
 - Internal performance of >250 MHz.
 - Over 400K usable system gates.
 - Meets multiple I/O interface standards.
 - 1.5V operation (30% less power than 1.8V operation) translates to greater performance.
 - Traditional I/O selections:
 - LVTTTL (3.3V) and LVCMOS (2.5V, and 1.8V) I/Os.
 - Per pin-selectable I/O clamping diodes provide 3.3V PCI compliance.
 - Individually programmable drive capability:
24 mA sink/12 mA source, 12 mA sink/6 mA source, or 6 mA sink/3 mA source.
 - Two slew rates supported (fast and slew-limited).
 - Fast-capture input latch and input Flip-Flop (FF)/latch for reduced input setup time and zero hold time.
 - Fast open-drain drive capability.
 - Capability to register 3-state enable signal.
 - Off-chip clock drive capability.
 - Two-input function generator in output path.
 - New programmable high-speed I/O:
 - Single-ended: GTL, GTL+, PECL, SSTL3/2 (class I and II), HSTL (Class I, III, IV), ZBT, and DDR.
 - Double-ended: LVDS, bused-LVDS, and LVPECL. Programmable (on/off), internal parallel termination (100 Ω) is also supported for these I/Os.
 - New capability to (de)multiplex I/O signals:
 - New DDR on both input and output.
 - New 2x and 4x downlink and uplink capability per I/O.
 - Enhanced twin-block Programmable Function Unit (PFU):
 - Eight 16-bit Look-Up Tables (LUTs) per PFU.
 - Nine user registers per PFU, one following each LUT, and organized to allow two nibbles to act independently, plus one extra for arithmetic operations.
 - New register control in each PFU has two independent programmable clocks, clock enables, local set/reset, and data selects.
 - New LUT structure allows flexible combinations of LUT4, LUT5, new LUT6, 4 \rightarrow 1 MUX, new 8 \rightarrow 1 MUX, and ripple mode arithmetic functions in the same PFU.
 - 32 x 4 RAM per PFU, configurable as single-port or dual-port. Create large, fast RAM/ROM blocks (128 x 8 in only eight PFUs) using the Supplemental Logic and Interconnect Cell (SLIC) decoders as bank drivers.
 - Soft-Wired LUTs (SWL) allow fast cascading of up to three levels of LUT logic in a single PFU through fast internal routing which reduces routing congestion and improves speed.
 - Flexible fast access to PFU inputs from routing.
 - Fast-carry logic and routing to all four adjacent PFUs for nibble-wide, byte-wide, or longer arithmetic functions, with the option to register the PFU carry-out.
-

-
- Abundant high-speed buffered and nonbuffered routing resources provide 2x average speed improvements over previous architectures.
 - Hierarchical routing optimized for both local and global routing with dedicated routing resources. This results in faster routing times with predictable and efficient performance.
 - Supplemental Logic and Interconnect Cell (SLIC) provides eight 3-statable buffers, up to a 10-bit decoder, and PAL™-like AND-OR-Invert (AOI) in each programmable logic cell.
 - New 200 MHz embedded block-port RAM blocks, 2 read ports, 2 write ports, and 2 sets of byte lane enables. Each embedded RAM block can be configured as:
 - 1—512 x 18 (block-port, two read/two write) with optional built in arbitration.
 - 1—256 x 36 (dual-port, one read/one write).
 - 1—1K x 9 (dual-port, one read/one write).
 - 2—512 x 9 (dual-port, one read/one write for each).
 - 2 RAMS with arbitrary number of words whose sum is 512 or less by 18 (dual-port, one read/one write).
 - Supports joining of RAM blocks.
 - Two 16 x 8-bit Content Addressable Memory (CAM) support.
 - FIFO 512 x 18, 256 x 36, 1Kx 9, or dual 512 x 9.
 - Constant multiply (8 x 16 or 16 x 8).
 - Dual variable multiply (8 x 8).
 - Embedded 32-bit internal system bus plus 4-bit parity interconnects FPGA logic, MicroProcessor Interface (MPI), embedded RAM blocks, and embedded standard cell blocks with 100 MHz bus performance. Included are built-in system registers that act as the control and status center for the device.
 - Built-in testability:
 - Full boundary scan (*IEEE* 1149.1 and Draft 1149.2 JTAG).
 - Programming and readback through boundary scan port compliant to *IEEE* Draft 1532:D1.7.
 - TS_ALL testability function to 3-state all I/O pins.
 - New temperature-sensing diode.
 - Improved built-in clock management with Programmable Phase-Locked Loops (PPLLs) provide optimum clock modification and conditioning for phase, frequency, and duty cycle from 15 MHz up to 420 MHz. Multiplication of the input frequency up to 64x and division of the input frequency down to 1/64x possible.
 - New cycle stealing capability allows a typical 15% to 40% internal speed improvement after final place and route. This feature also enables compliance with many setup/hold and clock to out I/O specifications and may provide reduced ground bounce for output buses by allowing flexible delays of switching output buffers.
 - PCI local bus compliant for FPGA I/Os.

Programmable Logic System Features

- Improved *PowerPC*® 860 and *PowerPC* II high-speed synchronous MicroProcessor Interface can be used for configuration, readback, device control, and device status, as well as for a general-purpose interface to the FPGA logic, RAMs, and embedded standard cell blocks. Glueless interface to synchronous *PowerPC* processors with user-configurable address space provided.
 - New embedded system bus facilitates communication among the MicroProcessor Interface, configuration logic, Embedded Block RAM, FPGA logic, and embedded standard cell blocks.
 - Variable size based readback of configuration data with the built-in MicroProcessor Interface and system bus.
 - Internal, 3-state, and bidirectional buses with simple control provided by the SLIC.
 - New clock routing structures for global and local clocking significantly increases speed and reduces skew.
 - New local clock routing structures allow creation of localized clock trees.
 - Two new edge clock routing structures allow up to six high-speed clocks on each edge of the device for improved
-

setup/hold and clock to out performance.

- New Double-Data Rate (DDR) and zero-bus turn-around (ZBT) memory interfaces support the latest high-speed memory interfaces.
- New 2x/4x uplink and downlink I/O capabilities interface high-speed external I/Os to reduced speed internal logic.
- ispLEVER™ development system software. Supported by industry-standard CAE tools for design entry, synthesis, simulation, and timing analysis.
- Meets Universal Test and Operations PHY Interface for ATM (UTOPIA) levels 1, 2, and 3; as well as POS-PHY3.

Description

What Is an FPSC?

FPSCs, or Field-Programmable System Chips, are devices that combine field-programmable logic with ASIC or mask-programmed logic on a single device. FPSCs provide the time to market and the flexibility of FPGAs, the design effort savings of using soft Intellectual Property (IP) cores, and the speed, design density, and economy of ASICs.

FPSC Overview

Lattice's Series 4 FPSCs are created from Series 4 *ORCA* FPGAs. To create a Series 4 FPSC, several columns of Programmable Logic Cells (see FPGA Logic Overview section for FPGA logic details) are added to an embedded logic core. Other than replacing some FPGA gates with ASIC gates, at greater than 10:1 efficiency, none of the FPGA functionality is changed—all of the Series 4 FPGA capability is retained: Embedded Block RAMs, MPI, PCMs, boundary scan, etc. The columns of programmable logic are replaced at the right of the device, allowing pins from the replaced columns to be used as I/O pins for the embedded core. The remainder of the device pins retain their FPGA functionality.

FPSC Gate Counting

The total gate count for an FPSC is the sum of its embedded core (standard-cell/ASIC gates) and its FPGA gates. Because FPGA gates are generally expressed as a usable range with a nominal value, the total FPSC gate count is sometimes expressed in the same manner. Standard-cell ASIC gates are, however, 10 to 25 times more silicon-area efficient than FPGA gates. Therefore, an FPSC with an embedded function is gate equivalent to an FPGA with a much larger gate count.

FPGA/Embedded Core Interface

The interface between the FPGA logic and the embedded core has been enhanced to allow a greater number of interface signals than on previous FPSC architectures. Compared to bringing embedded core signals off-chip, this on-chip interface is much faster and requires less power. All of the delays for the interface are precharacterized and accounted for in the ispLEVER Development System.

ORCA Series 4 based FPSCs expand this interface by providing a link between the embedded block and the multi-master 32-bit system bus in the FPGA logic. This system bus allows the core easy access to many of the FPGA logic functions including the Embedded Block RAMs and the MicroProcessor Interface.

Clock spines also can pass across the FPGA/embedded core boundary. This allows for fast, low-skew clocking between the FPGA and the embedded core. Many of the special signals from the FPGA, such as DONE and global set/reset, are also available to the embedded core, making it possible to fully integrate the embedded core with the FPGA as a system.

For even greater system flexibility, FPGA configuration RAMs are available for use by the embedded core. This supports user-programmable options in the embedded core, in turn allowing for greater flexibility. Multiple embedded core configurations may be designed into a single device with user-programmable control over which configurations are implemented, as well as the capability to change core functionality simply by reconfiguring the device.

ispLEVER Development System

The ispLEVER development system is used to process a design from a netlist to a configured FPGA. This system is used to map a design onto the *ORCA* architecture, and then place and route it using ispLEVER development system timing-driven tools. The development system also includes interfaces to, and libraries for, other popular CAE tools for design entry, synthesis, simulation, and timing analysis.

FPSC Design Kit

Development is facilitated by an FPSC design kit which, together with ispLEVER and third-party synthesis and simulation engines, provides all software and documentation required to design and verify an FPSC implementation. Included in the kit are the FPSC configuration manager and/or compiled *Verilog* simulation model, *HSPICE* and/or IBIS models for I/O buffers, and complete online documentation. The kit's software couples with ispLEVER, providing a seamless FPSC design environment.

ORSO82G5/42G5 FPGA Logic Overview

The following sections provide a brief overview of the main architectural features of the ORSO82G5/42G5 FPGA logic. For more detailed information, refer to the ORCA Series 4 FPGA Data Sheet which can be found on the Lattice web site at www.latticesemi.com. The ORCA Series 4 FPGA Data Sheet provides detailed information required for designing with the ORSO82G5/42G5 device. Topics covered in the ORCA Series 4 Data Sheet include:

- FPGA Logic Architecture
- FPGA Routing Resources
- FPGA Clock Routing Resources
- FPGA Programmable Input/Output Cells (PICs)
- FPGA Embedded Block RAM (EBR)
- Microprocessor Interface (MPI)
- Phase-Locked Loops (PLLs)
- Electrical Characteristics
- FPGA Timing Characteristics
- Power-up
- Configuration

ORCA Series 4 FPGA Logic Overview

The *ORCA* Series 4 architecture is a new generation of SRAM-based programmable devices from Lattice. It includes enhancements and innovations geared toward today's high-speed systems on a single chip. Designed with networking applications in mind, the Series 4 family incorporates system-level features that can further reduce logic requirements and increase system speed. *ORCA* Series 4 devices contain many new patented enhancements and are offered in a variety of packages and speed grades.

The hierarchical architecture of the logic, clocks, routing, RAM, and system-level blocks create a seamless merge of FPGA and ASIC designs. Modular hardware and software technologies enable system-on-chip integration with true plug-and-play design implementation.

The architecture consists of four basic elements: Programmable Logic Cells (PLCs), programmable I/O cells (PIOs), Embedded Block RAMs (EBRs), and system-level features. These elements are interconnected with a rich routing fabric of both global and local wires. An array of PLCs are surrounded by common interface blocks which provide an abundant interface to the adjacent PLCs or system blocks. Routing congestion around these critical blocks is eliminated by the use of the same routing fabric implemented within the programmable logic core. Each PLC contains a PFU, SLIC, local routing resources, and configuration RAM. Most of the FPGA logic is performed in the PFU, but decoders, *PAL*-like functions, and 3-state buffering can be performed in the SLIC. The PIOs provide

device inputs and outputs and can be used to register signals and to perform input demultiplexing, output multiplexing, uplink and downlink functions, and other functions on two output signals. Large blocks of 512 x 18 block-port RAM complement the existing distributed PFU memory. The RAM blocks can be used to implement RAM, ROM, FIFO, multiplier, and CAM. Some of the other system-level functions include the MPI, PLLs, and the Embedded System Bus (ESB).

PLC Logic

Each PFU within a PLC contains eight 4-input (16-bit) LUTs, eight latches/FFs, and one additional Flip-Flop that may be used independently or with arithmetic functions.

The PFU is organized in a twin-block fashion; two sets of four LUTs and FFs that can be controlled independently. Each PFU has two independent programmable clocks, clock enables, local set/reset, and data selects. LUTs may also be combined for use in arithmetic functions using fast-carry chain logic in either 4-bit or 8-bit modes. The carry-out of either mode may be registered in the ninth FF for pipelining. Each PFU may also be configured as a synchronous 32 x 4 single- or dual-port RAM or ROM. The FFs (or latches) may obtain input from LUT outputs or directly from invertible PFU inputs, or they can be tied high or tied low. The FFs also have programmable clock polarity, clock enables, and local set/reset.

The SLIC is connected from PLC routing resources and from the outputs of the PFU. It contains eight 3-state, bidirectional buffers, and logic to perform up to a 10-bit AND function for decoding, or an AND-OR with optional INVERT to perform *PAL*-like functions. The 3-state drivers in the SLIC and their direct connections from the PFU outputs make fast, true, 3-state buses possible within the FPGA, reducing required routing and allowing for real-world system performance.

Programmable I/O

The Series 4 PIO addresses the demand for the flexibility to select I/Os that meet system interface requirements. I/Os can be programmed in the same manner as in previous *ORCA* devices, with the additional new features which allow the user the flexibility to select new I/O types that support High-Speed Interfaces.

Each PIO contains four programmable I/O pads and is interfaced through a common interface block to the FPGA array. The PIO is split into two pairs of I/O pads with each pair having independent clock enables, local set/reset, and global set/reset. On the input side, each PIO contains a programmable latch/Flip-Flop which enables very fast latching of data from any pad. The combination provides for very low setup requirements and zero hold times for signals coming on-chip. It may also be used to demultiplex an input signal, such as a multiplexed address/data signal, and register the signals without explicitly building a demultiplexer with a PFU.

On the output side of each PIO, an output from the PLC array can be routed to each output Flip-Flop, and logic can be associated with each I/O pad. The output logic associated with each pad allows for multiplexing of output signals and other functions of two output signals.

The output FF, in combination with output signal multiplexing, is particularly useful for registering address signals to be multiplexed with data, allowing a full clock cycle for the data to propagate to the output. The output buffer signal can be inverted, and the 3-state control can be made active-high, active-low, or always enabled. In addition, this 3-state signal can be registered or nonregistered.

The Series 4 I/O logic has been enhanced to include modes for speed uplink and downlink capabilities. These modes are supported through shift register logic, which divides down incoming data rates or multiplies up outgoing data rates. This new logic block also supports high-speed DDR mode requirements where data are clocked into and out of the I/O buffers on both edges of the clock.

The new programmable I/O cell allows designers to select I/Os which meet many new communication standards permitting the device to hook up directly without any external interface translation. They support traditional FPGA standards as well as high-speed, single-ended, and differential-pair signaling. Based on a programmable, bank-oriented I/O ring architecture, designs can be implemented using 3.3V, 2.5V, 1.8V, and 1.5V referenced output levels.

Routing

The abundant routing resources of the Series 4 architecture are organized to route signals individually or as buses with related control signals. Both local and global signals utilize high-speed buffered and nonbuffered routes. One PLC segmented (x1), six PLC segmented (x6), and bused half chip (xHL) routes are patterned together to provide high connectivity with fast software routing times and high-speed system performance.

Eight fully distributed primary clocks are routed on a low-skew, high-speed distribution network and may be sourced from dedicated I/O pads, PLLs, PLC logic or the Embedded Core. Secondary and edge-clock routing is available for fast regional clock or control signal routing for both internal regions and on device edges. Secondary clock routing can also be sourced from any I/O pin, PLLs, PLC logic or the Embedded Core.

The improved routing resources offer great flexibility in moving signals to and from the logic core. This flexibility translates into an improved capability to route designs at the required speeds when the I/O signals have been locked to specific pins.

System Level Features

The Series 4 also provides system-level functionality by means of its MicroProcessor Interface, Embedded System Bus, block-port Embedded Block RAMs, universal Programmable Phase-Locked Loops, and the addition of highly tuned networking specific Phase-Locked Loops. These functional blocks allow for easy glueless system interfacing and the capability to adjust to varying conditions in today's high-speed networking systems.

MicroProcessor Interface

The MPI provides a glueless interface between the FPGA and *PowerPC* microprocessors. Programmable in 8-, 16-, and 32-bit interfaces with optional parity to the *Motorola*® *PowerPC* 860 bus, it can be used for configuration and readback, as well as for FPGA control and monitoring of FPGA status. All MPI transactions utilize the Series 4 Embedded System Bus at 66 MHz performance.

The MicroProcessor Interface (MPI) provides a system-level interface, using the system bus, to the FPGA user-defined logic following configuration, including access to the Embedded Block RAM and general logic. The MPI supports burst data read and write transfers, allowing short, uneven transmission of data through the interface by including data FIFOs. Transfer accesses can be single beat (1 x 4 bytes or less), 4-beat (4 x 4 bytes), 8-beat (8 x 2 bytes), or 16-beat (16 x 1 bytes).

System Bus

An on-chip, multimaster, 32-bit system bus with 4-bit parity facilitates communication among the MPI, configuration logic, FPGA control, and status registers, Embedded Block RAMs, as well as user logic. The Embedded System Bus offers arbiter, decoder, master, and slave elements. Master and slave elements are also available for the user-logic and a slave interface is used for control and status of the embedded backplane transceiver portion of the ORSO42G5 and ORSO82G5.

The system bus control registers can provide control to the FPGA such as signaling for reprogramming, reset functions, and PLL programming. Status registers monitor INIT, DONE, and system bus errors. An interrupt controller is integrated to provide up to eight possible interrupt resources. Bus clock generation can be sourced from the MicroProcessor Interface clock, configuration clock (for slave configuration modes), internal oscillator, user clock from routing, or from the port clock (for JTAG configuration modes).

Phase-Locked Loops

Up to eight PLLs are provided on each Series 4 device, with four user PLLs generally provided for FPSCs, including the ORSO42G5 and ORSO82G5. In the FPSCs, these PLLs can only be driven by the FPGA resources. Programmable PLLs can be used to manipulate the frequency, phase, and duty cycle of a clock signal. Each PLL is capable of manipulating and conditioning clock outputs from 15 MHz to 420 MHz. Frequencies can be adjusted from 1/8x to 8x, the input clock frequency. Each programmable PLL provides two outputs that have different multiplication factors but can have the same phase relationships. Duty cycles and phase delays can be adjusted in

12.5% of the clock period increments. An automatic input buffer delay compensation mode is available for phase delay. Each PLL provides two outputs that can have programmable (12.5% steps) phase differences.

Embedded Block RAM

New 512 x 18 block-port RAM blocks are embedded in the FPGA core to significantly increase the amount of memory and complement the distributed PFU memories. The EBRs include two write ports, two read ports, and two byte lane enables which provide four-port operation. Optional arbitration between the two write ports is available, as well as direct connection to the high-speed system bus.

Additional logic has been incorporated to allow significant flexibility for FIFO, constant multiply, and two-variable multiply functions. The user can configure FIFO blocks with flexible depths of 512K, 256K, and 1K including asynchronous and synchronous modes and programmable status and error flags. Multiplier capabilities allow a multiply of an 8-bit number with a 16-bit fixed coefficient or vice versa (24-bit output), or a multiply of two 8-bit numbers (16-bit output). On-the-fly coefficient modifications are available through the second read/write port.

Two 16 x 8-bit CAMs per embedded block can be implemented in single match, multiple match, and clear modes. The EBRs can also be preloaded at device configuration time.

Configuration

The FPGAs functionality is determined by internal configuration RAM. The FPGAs internal initialization/configuration circuitry loads the configuration data at powerup or under system control. The configuration data can reside externally in an EEPROM or any other storage media. Serial EEPROMs provide a simple, low pin-count method for configuring FPGAs.

The RAM is loaded by using one of several configuration modes. Supporting the traditional master/slave serial, master/slave parallel, and asynchronous peripheral modes, Series 4 also utilizes its MicroProcessor Interface and Embedded System Bus to perform both programming and readback. Daisy chaining of multiple devices and partial reconfiguration are also permitted.

Other configuration options include the initialization of the embedded-block RAM memories and FPSC memory as well as system bus options and bit stream error checking. Programming and readback through the JTAG (*IEEE 1149.2*) port is also available meeting In-System Programming (ISP) standards (*IEEE 1532 Draft*).

ORSO42G5 and ORSO82G5 Overview

The ORSO42G5 and ORSO82G5 FPSCs provide high-speed backplane transceivers combined with FPGA logic. The ORSO42G5 and ORSO82G5 devices are based on the 1.5V OR4E04 ORCA FPGA and have a 36 x 36 array of Programmable Logic Cells (PLCs). The embedded core, which contains the backplane transceivers, is attached to the right side of the device and is integrated directly into the FPGA array. A top level diagram of the basic chip configuration is shown in Figure 1.

Figure 1. ORSO42G5 and ORSO82G5 Basic Chip Configuration

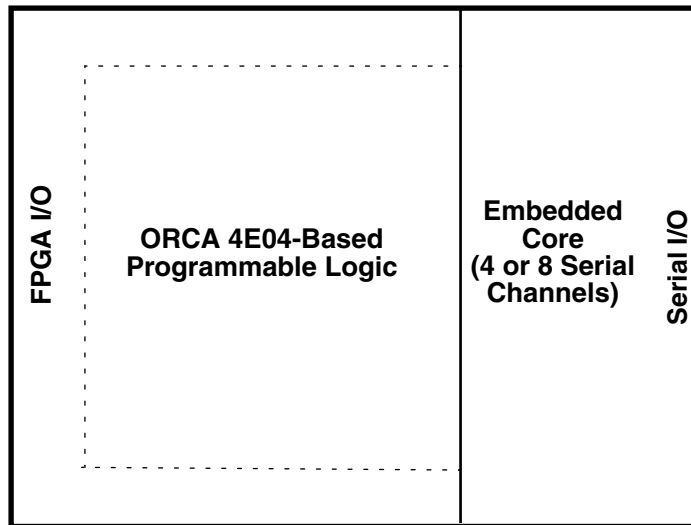

The ORSO42G5 and ORSO82G5 support aggregate bandwidths over 10Gbps and are targeted towards users needing high-speed backplane interfaces for SONET and other non-SONET proprietary backplanes. For non-SONET applications, all SONET functionality is hidden from the user and no prior networking knowledge is required.

Built using Series 4 reconfigurable System-on-a-Chip (SoC) architecture, the ORSO42G5 and ORSO82G5 contain the FPGA base array and an embedded core supporting eight serial data channels, with clock and data recovery functions, and provides SONET framing, scrambling/descrambling and cell processing on a single monolithic chip to enable high-speed asynchronous serial data transfer between system devices. Devices can be on the same PC-board, on separate boards connected across a backplane or connected by cables. The ORSO42G5 and ORSO82G5 are completely pin-compatible with the ORT42G5 and ORT82G5 devices.

The ORSO42G5 and ORSO82G5 are considered pseudo-SONET devices because they do not support full overhead processing, pointer processing or meet all SONET jitter/timing requirements. The ORSO42G5 and ORSO82G5 are designed primarily for use as SONET backplane devices and not for network termination. Although they format and process data as SONET frames, they cannot terminate data directly on a SONET ring without additional functionality being implemented in the FPGA logic because the embedded core is not fully SONET compliant on a stand-alone basis.

The ORSO42G5 and ORSO82G5 embedded cores support the following:

- Section/Line Overhead: A1/A2 (framing bytes), B1 (BIP-8), K2 (APS)
- Alarms: OOF (Out Of Frame), B1 error, RDI
- Two modes of automatic Transport OverHead (TOH) generation and insertion
- AIS-L insertion
- SPE signal generation which support +/- stuff events (but no pointer processing)

Embedded Core Overview

The functions in the embedded core portion of the ORSO42G5 and ORSO82G5 devices include:

- Eight channel 2.7 Gbps serializer/deserializer functions with Clock and Data Recovery (CDR).
- Eight-bit Interface to the Series 4 system bus for control and status information exchange.

- Support for OC-48 and OC-192 (in block OC-48) formats.
- SONET framing, scrambling and SONET Mode channel alignment.
- Performance monitoring functions such as Bit Interleaved Parity (BIP-8) generation and checking and Out-Of-Frame (OOF) and Remote Defect Indication (RDI-L) detection.
- Cell Mode cell creation and extraction, idle cell insertion/deletion, destriping and striping functions.
- Additionally, there are two independent memory blocks in the core. Each embedded RAM block has a capacity of 4K words by 36 bits.

The ORSO42G5 and ORSO82G5 embedded cores contain, respectively, four-channel and eight-channel clock and data recovery macrocells and logical blocks performing functions such as SONET framing, scrambling/descrambling and cell processing. The channels each operate from 0.6 to 2.7 Gbps with per channel CDR functionality. The CDR interface enables high-speed asynchronous serial data transfer between system devices. Devices can be on the same PC-board, on separate boards connected across a backplane, or connected by cables. Figure 2 shows a top level block diagram of the backplane driver logic in the embedded core (embedded RAM not shown).

Figure 2. Top Level Block Diagram ORSO42G5 and ORSO82G5 Embedded Cores

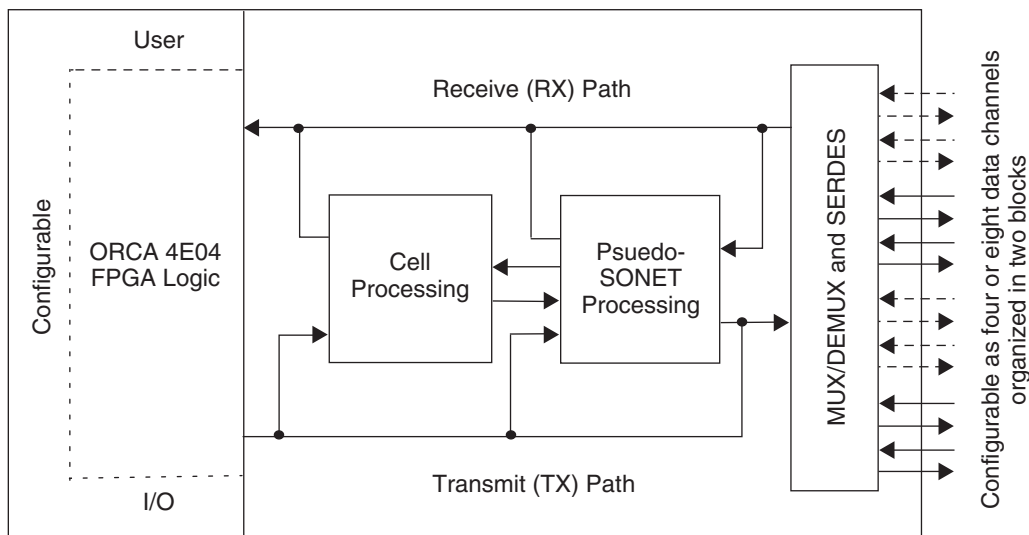

ORSO42G5 and ORSO82G5 Main Operating Modes - Overview

The ORSO42G5 and ORSO82G5 support four and eight 0.6 to 2.7 Gbps serial data channels respectively, which can operate independently or can be combined together (aligned) to achieve higher bit rates. The mode of operation of the core is defined by a set of control registers, which can be written through the system bus interface. The status of the core is stored in a set of status registers, which can be read through the system bus interface.

The serial data channels support OC-48 rates on each channel. The standard OC-48 rate, 2.488 Gbits, is used as the nominal data rate for the technical discussions that follow. OC-192 is also supported but is transmitted and received in block OC-48 links. The scrambled data stream conforms to the GR-255 specified polynomial sequence of $1+x^6+x^7$.

There are three main operating modes in the ORSO42G5 and ORSO82G5 as described below:

- SERDES only (bypass) mode
- SONET mode
- Cell mode
 - Two-link sub-mode
 - Eight-link sub-mode (ORSO82G5 only)

There are sub-modes that can be derived by enabling or disabling certain functions through programmable register bits. Also, in cell mode, either the two-link alignment mode, for up to four alignment groups, or the eight-link alignment mode, where all eight links are combined into a single group, may be selected.

Data are processed in the transmit direction (FPGA to Backplane) as follows:

- In the **SERDES only mode**, there is the option to bypass all of the SONET and cell functions and pass raw 32-bit data from the FPGA into the 32:8 MUX block. In this mode, the user is responsible for providing an adequate ones transition density in the transmitted stream for clock and data recovery at the receive end of the link.
- In the **SONET mode**, a SONET frame is constructed around the input data and overhead bytes are inserted where appropriate. The 32-bits of data per channel are scrambled before being converted to 8-bits by the 32:8 MUX block and serialized by the SERDES.
- In the **cell mode**, 160 bits of data from the FPGA is sent to the Output Port Controller-8 block (for the ORSO82G5 only, the block is also referred to as OPC8 since it services eight links) or 40 bits of data to an Output Port Controller-2 block (referred to as the OPC2) which perform cell striping across the different SERDES links. The cells are then transferred to the SONET clock domain of 77.76 MHz through a Transmit FIFO. A SONET frame is constructed around the cell payload and overhead bytes inserted where appropriate before being sent to the MUX block. The data are then converted to 8 bits by the 32:8 MUX block before being serialized by the SERDES.

Data are processed in the receive direction (Backplane to FPGA) as follows:

- In the **SERDES only mode**, there is the option to bypass all of the SONET and cell functions and pass raw 32-bit data from the 8:32 DEMUX block into the FPGA interface.
- In the **SONET mode**, the descrambled data are sent to an alignment FIFO that performs lane-to-lane deskew and aligns data within an alignment group to a single clock domain and frame pulse. The SPE indicator is provided to the FPGA along with 32 bits of aligned data. There is an option to bypass the alignment FIFOs and pass data directly from the descrambler to the FPGA. This mode is programmable and can be controlled per channel.
- In the **cell mode**, the SONET framed data are descrambled and passed into a cell extractor which extracts cells from the payload portion of the SONET frame. The cells are passed through a FIFO which performs lane-to-lane deskew and a clock domain transfer from the SONET clock domain to the cell processing domain. The cells are passed into the input port controller block (referred to as IPC8 or IPC2 depending on whether eight or two links are serviced) which performs cell destriping before sending them to the FPGA interface. This cell processing feature makes the ORSO42G5 and ORSO82G5 ideal for interfacing devices with proprietary data formats across a backplane.

Embedded Core Functional Blocks - Overview

Each channel contains transmit path and receive path logic as shown in Figure 2. Data are processed on a channel by channel basis in the SERDES only and SONET modes. Channel by channel processing is also performed in the cell mode by the Input Port Controller (IPC) and Output Port Controller (OPC) blocks. Support for loopback is also provided but is not shown in Figure 2. The following sections will give an overview of the pseudo SONET protocol supported by the ORSO42G5 and ORSO82G5 and a top level overview of the macrocells, which provide the SERDES Only, SONET and cell mode functionality.

SERializer and DESerializer (SERDES)

Each SERDES block is a block transceiver containing two or four channels for serial data transmission, with a per-channel selectable data rate of 0.6-2.7 Gbps. Each SERDES block features high-speed CML interfaces and is designed to operate in SONET backplane applications. The transceiver is controlled and configured via an 8-bit slave interface on the system bus. Each channel has dedicated registers that are readable and writable. The device also contains global registers for control of common circuitry and functions. There are two SERDES blocks, A and B, in the embedded portion of the device. Each block supports full duplex serial links in the ORSO82G5 (Slice A contains channels AA, AB, AC, and AD while slice B contains channels BA, BB, BC, and BD). A similar naming

convention is used for the ORSO42G5. Slice A contains channels AC and AD while Slice B contains channels AC and AD.

Each SERDES block contains its own dedicated PLLs for transmit and receive clock generation. The user provides a reference clock of the appropriate frequency (one per SERDES block). The receiver PLLs extract the clock from the serial input data and retime the data with the recovered clock. Clock divider circuitry also provides reference clocks for the FPGA logic.

8:32 MUX and 32:8 DEMUX

The purpose of the MUX/DEMUX block is to provide a wide, low-speed interface at the FPGA portion of the ORSO42G5 and ORSO82G5 for each channel or data lane. The interface to the SERDES macro runs at 1/8th the bit rate of the data lane. The MUX/DEMUX converts the data rate and bit-width so the FPGA core can run at 1/4th this frequency (i.e., 1/32nd the SERDES rate). This gives a range of 18.75 MHz-84.38 MHz for the data crossing the FPGA/embedded core boundary on SERDES only and SONET modes.

SONET Transmit OverHead (TOH) Processing, Framer and Scrambler/Descrambler (SONET and Cell Modes)

In the transmit direction, the TOH block is responsible for processing the 144 (48 x 3) TOH bytes at the beginning of each row of the transport frame. The TOH bytes may be transmitted transparently from the FPGA logic or may be inserted by the TOH block (AUTO_SOH and AUTO_TOH modes).

The TOH block can perform A1/A2 corruption by inverting the A1/A2 bytes under software control. The block can also force B1 errors by inverting the B1 byte or inject a fault indication by forcing the K2 byte to "0000110". In the receive direction, the errors will be detected and alarms set. In SONET mode, all TOH bytes can optionally be sent transparently from the FPGA.

For each of the receive channels, the framer logic outputs four bytes (32-bits) of received data that are frame-aligned and a frame pulse that is one clock-wide. The framer is responsible also for detecting the in-frame and Out-Of-Frame status of the incoming data and sends out alarms (interrupts) on detecting an Out-Of-Frame (OOF) state.

In the transmit direction, the scrambler logic scrambles the outgoing data using the standard SONET polynomial $1 + x^6 + x^7$. In the receive direction, the descrambler logic descrambles the incoming data using the same polynomial.

Multichannel Alignment FIFO and SPE Generation (for SONET mode)

In SONET mode, the incoming data on the channels can be independent of one another or can be synchronized in several ways. Two channels within a SERDES block can be aligned together. Alternately, four channels can be aligned to form a communication channel with a bandwidth of 10 Gbps. Finally, in the ORSO82G5, the alignment can be extended across all of the SERDES to align all eight channels.

Individual channels within an alignment group can be disabled (i.e., power down) without disrupting other channels. A disabled channel can also be aligned to its group without a disruption to the remaining channels. This holds true only if the disabled channel had been previously enabled during alignments.

Cell Extraction, Striping and Destriping (for Cell Mode)

In the cell mode, cells are distributed across two-links or, in the ORSO82G5, across eight-links. In the TX direction, cell data from the FPGA are "striped" across links within a link group. In the receive direction cell processing blocks extract cells from the link groups and send them to the FPGA. This function is referred to as "destriping".

Loopback - Overview

There are two types of loopback that can be utilized inside the embedded core of the ORSO42G5 and ORSO82G5, near end loopback and far end (line side) loopback. Both of these loopbacks are controlled by control registers inside the ORSO42G5 and ORSO82G5 core, which are accessible from the system bus and the Micro-Processor Interface (MPI).

Dual Port RAMs

There are two independent memory blocks in the core. Each memory block has a capacity of 4K words by 36 bits. It has one read port, one write port, and four byte-write-enable (active-low) signals. The read data from the memory block is registered so that it works as a pipelined synchronous memory block. These memory blocks are completely independent of the backplane driver blocks. They are only accessible from the FPGA logic and are not connected to the system bus.

FPSC Configuration - Overview

Configuration of the ORSO42G5 and ORSO82G5 occurs in two stages: FPGA bit stream configuration and embedded core setup.

Prior to becoming operational, the FPGA goes through a sequence of states, including power-up, initialization, configuration, start-up, and operation. The FPGA logic is configured by standard FPGA bit stream configuration means as discussed in the Series 4 FPGA data sheet.

The options for the embedded core are set via registers that are accessed through the FPGA system bus. The system bus can be driven by an external PPC compliant microprocessor via the MPI block or via a user master interface in FPGA logic. A simple IP block, that drives the system by using the user interface and uses very little FPGA logic, is available in the *MPI/System Bus* application note (TN1017). This IP block sets up the embedded core via a state machine and allows the ORSO42G5 and ORSO82G5 to work in an independent system without an external MicroProcessor Interface.

ORSO42G5 and ORSO82G5 Embedded Core Detailed Description

The ORSO42G5 and ORSO82G5 have four and eight channels respectively, with a high-speed SERDES macro that performs clock data recovery, serializing and deserializing functions. There is also additional logic for SONET mode and cell mode data synchronization formatting and scrambling/descrambling. For all modes, the data paths can be characterized as the transmit path (FPGA to backplane) and receive path (backplane to FPGA); however the interface signal assignments between the FPGA logic and the core differ depending on the operating mode selected.

The three main operating modes in the ORSO42G5 and ORSO82G5 are:

- SERDES only mode
- SONET mode
- Cell mode
 - Two-link sub-mode
 - Eight-link sub-mode (ORSO82G5 only)

The SONET and cell modes each support sub-modes that can be selected by enabling or disabling certain functions through programmable register bits. Following the basic TX and RX architecture descriptions, the data formatting and logical implementations supporting each of the operational modes are described.

Top Level Description - Transmitter (TX) and Receiver (RX) Architectures

The next sections give a top level description of the transmitter and receive architectures. The high-speed transmit and receive serial data can operate at 0.6-2.7 Gbps depending on the state of the control bits from the system bus and the provided reference clock. For all of the architecture and clock distribution descriptions, however, the standard SONET STS-48 rate of 2,488.32 Mbits/s (i.e., REFCLK_[P:N] = 155.52 MHz for the full rate modes) is assumed.

Transmitter Architecture

The transmitter section accepts parallel data for transmission from the FPGA logic, formats it for transmission and serializes the data. It also accepts the low-speed reference clock at the REFCLK input and uses this clock to synthesize the internal high-speed serial bit clock. The serialized transmitted data are available at the differential CML output pins to drive either an optical transmitters, coaxial media or a circuit board backplane.

The top level transmit architecture is shown in Figure 3. The main logical blocks in the transmit path are:

- Output Port Controllers (OPCs) which contain the cell processing logic.
- SONET processing logic.
- Transmit SERDES and 32:8 MUX.

Depending on the mode of operation, the FPGA to backplane data path may include or bypass the various logical blocks.

Figure 3. Top Level Overview, TX Path Logic, Single Channel

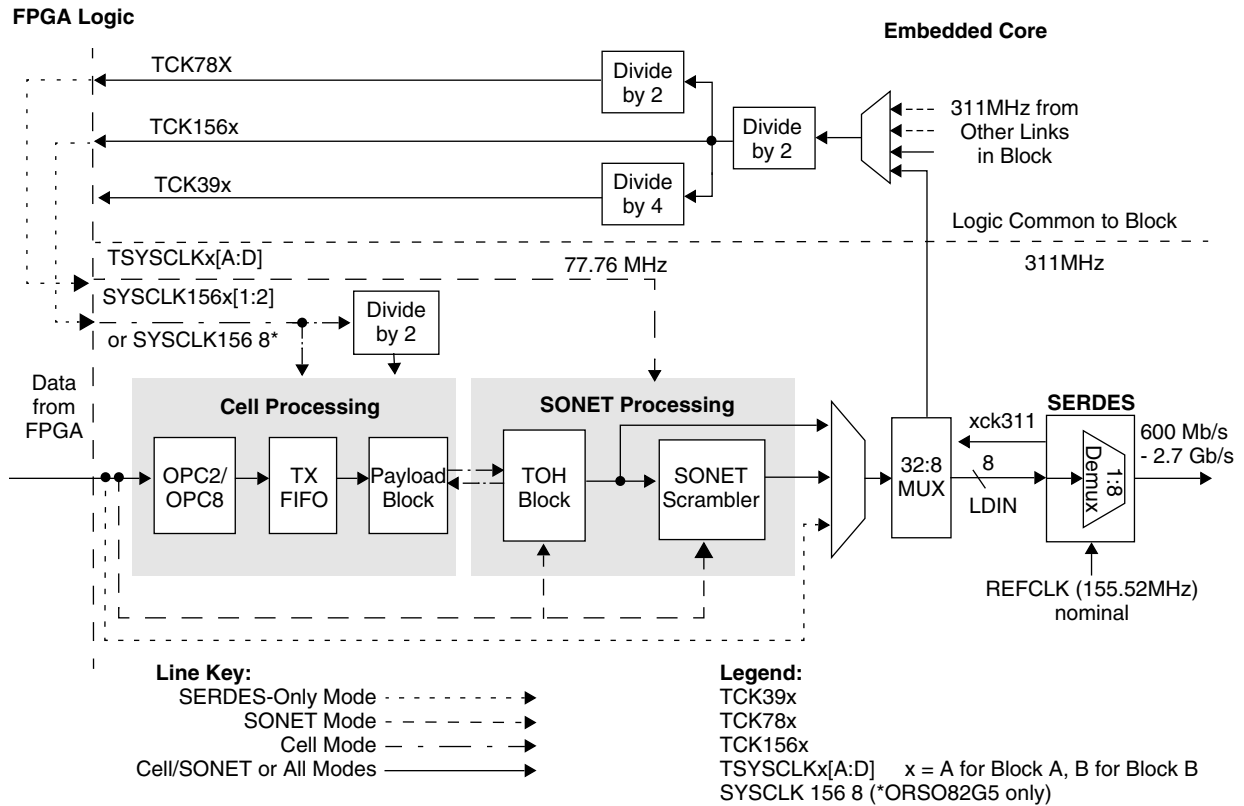

Receiver Architecture

The receiver section receives high-speed serial data at the external differential CML input pins. These data are fed to the clock recovery section which generates a recovered clock and retimes the data. Therefore the receive clocks are asynchronous between channels. The data are then optionally framed, reformatted, aligned and passed to the FPGA logic in various parallel data formats.

The top level receiver architecture is shown in Figure 4. The main logical blocks in the receive path are:

- Receive SERDES and 8:32 DEMUX.
- SONET processing logic.
- Input Port Controllers (IPCs) which contain the cell processing logic.

Depending on the mode of operation, the FPGA to backplane data path may include or bypass the various logical blocks.

Figure 4. Top Level Overview, RX Path Logic, Single Channel

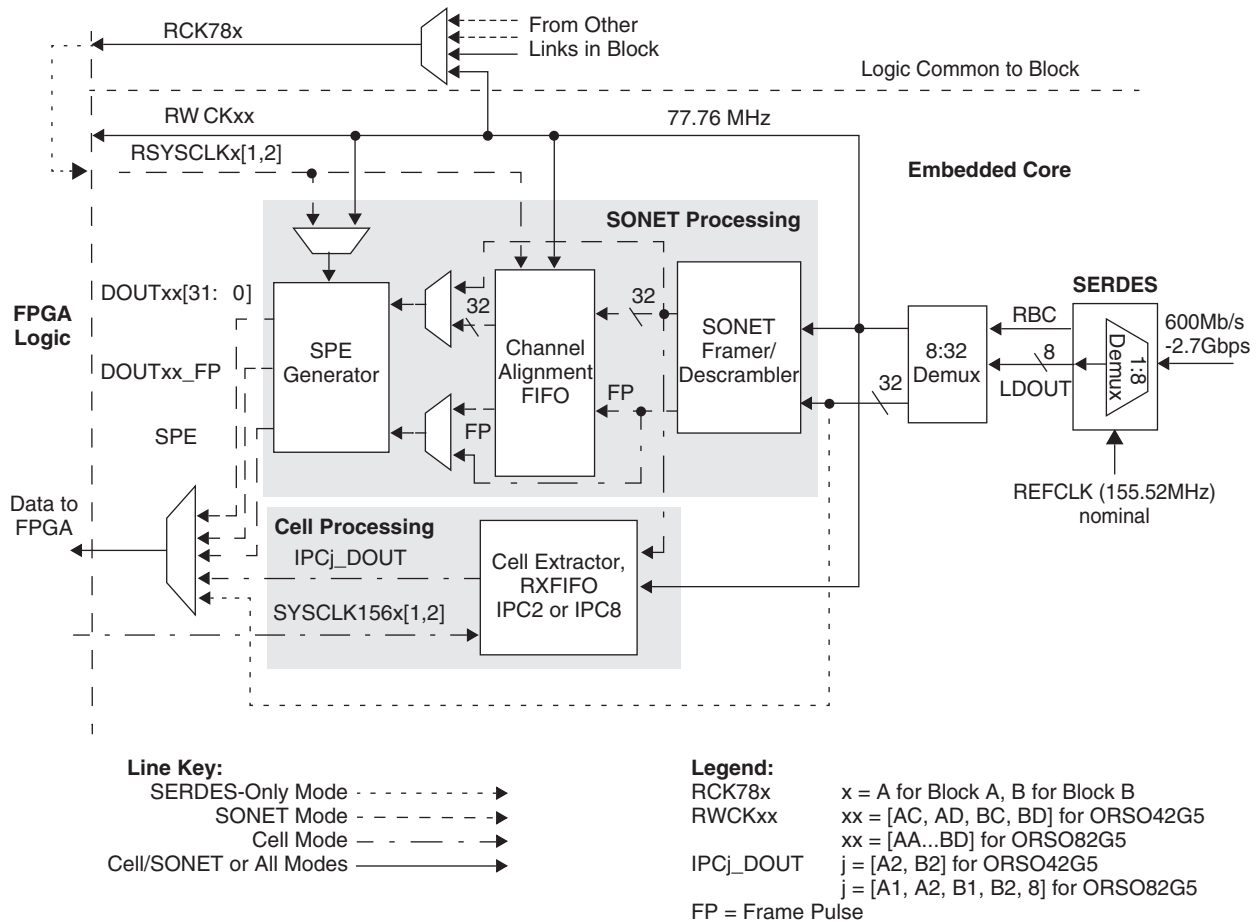

In either the SONET or cell mode, data from the DEMUX is then passed through a framer which word aligns and frames the data. Data are then processed based on cell mode or SONET mode selection.

In the SONET mode, the descrambled data are sent to an alignment FIFO that performs lane-to-lane deskew and optionally aligns data within a multi-channel alignment group. In addition, supervisory features such as BIP error check, OOF check, RDI monitoring and AIS-L insertion during OOF are also implemented. All the supervisory features are controlled through programmable register bits.

In the cell mode, the framed data are then descrambled and passed into a cell extractor which extracts cells from the payload portion of the SONET frame. The cells are passed through a FIFO that performs lane-to-lane deskew and a clock domain transfer from 77.76 MHz to 155.52 MHz. A key feature in cell mode is the ability to use idle cell insertion and deletion for automatic rate matching between the clock domains. The cells are then passed to the IPC2 block (or, in the ORSO82G5, to the IPC8 block) which perform cell destripping before sending the cells to the FPGA logic across the Core/FPGA interface.

SERDES Transmit and Receive PLLs

The high-speed transmit and receive serial data can operate at 0.6 to 2.7 Gbps depending on the state of the control bits from the system bus. Table 2 shows the relationship between the data rates, the reference clock, and the internal transmit TCK78x clocks.

Table 2. Transmit PLL Clock and Data Rates

| Data Rate | Reference Clock | TCK78x | Rate |
|------------|-----------------|-----------|------|
| 0.6 Gbps | 75.00 MHz | 18.75 MHz | Half |
| 1.0 Gbps | 125.00 MHz | 31.25 MHz | Half |
| 1.244 Gbps | 155.52 MHz | 38.88 MHz | Half |
| 1.35 Gbps | 168.75 MHz | 42.19 MHz | Half |
| 2.0 Gbps | 125.00 MHz | 61.50 MHz | Full |
| 2.488 Gbps | 155.52 MHz | 77.76 MHz | Full |
| 2.7 Gbps | 168.75 MHz | 84.38 MHz | Full |

Notes:

1. The selection of full-rate or half-rate for a given reference clock speed is set by the TXHR bit in the transmit control register and can be set per channel. (For cell mode all channels of a group must have the same TXHR selection.)

The receiver section receives high-speed serial data at its differential CML input port. These data are fed to the clock recovery section which generates a recovered clock and retimes the data. This means that the receive clocks are asynchronous between channels. The retimed data are deserialized and presented as a 8-bit parallel data on the output port. RWCKx receive byte clocks are divide-by-4 clocks of the RBC (recovered byte clock) clock provided by the SERDES. This is the clock used in the internal receive functions of the embedded core.

The reference clock is also used by the receive PLL for operation when the input data are not toggling appropriately. Table 3 shows the relationship between the data rates, the reference clock, and the RWCKx clocks.

Table 3. Receive PLL Clock and Data Rates

| Data Rate | Reference Clock | RWCKx Clocks | Rate |
|------------|-----------------|--------------|------|
| 0.6 Gbps | 75.00 MHz | 18.75 MHz | Half |
| 1.0 Gbps | 125.00 MHz | 31.25 MHz | Half |
| 1.244 Gbps | 155.52 MHz | 38.88 MHz | Half |
| 1.35 Gbps | 168.75 MHz | 42.19 MHz | Half |
| 2.0 Gbps | 125.00 MHz | 61.50 MHz | Full |
| 2.488 Gbps | 155.52 MHz | 77.76 MHz | Full |
| 2.7 Gbps | 168.75 MHz | 84.38 MHz | Full |

Note: The selection of full-rate or half-rate for a given reference clock speed is set by the RXHR bit in the receive control register and can be set per channel. (For cell mode all channels of a group must have the same RXHR selection).

The differential reference clock is distributed to all channels in a SERDES block. Each channel has a differential buffer to isolate the clock from the other channels. The input clock is preferably a differential signal; however, the device can operate with a single-ended input. The input reference clock directly impacts the transmit data eye, so the clock should have low jitter. In particular, jitter components in the DC-5 MHz range should be minimized.

Detailed Description - SERDES Only Mode

The SERDES only (or bypass) mode is the simplest of the three operating modes for the ORSO42G5 and ORSO82G5. In this mode, all of the SONET and cell logic block functions are bypassed and data are transferred directly between the MUX and DEMUX blocks to and from the FPGA interface. This mode is utilized when the user wants to perform all data processing and uses only the SERDES portion of the Embedded Core. For example, this mode could be utilized to replace an existing design using stand-alone SERDES and FPGAs.

The basic data paths in the transmit and receive directions are shown in Figure 5. In general, the descriptions in this section are written to describe the SERDES only mode, although the “SERDES blocks” are also used in SONET and cell mode operation. At the backplane interface, data are transmitted and received serially over pairs

of differential 0.6 to 2.7 Gbit/s links. At the FPGA/Embedded Core interface, the data are transferred across 32-bit buses. The SERDES blocks themselves are organized as two blocks. Each of the data paths is identified with a block and channel identifier (i.e., AC, AD, BC, BD or AA,...,BD).

Each channel has a 32-bit TX bus, 32-bit RX bus, a recovered clock, a transmit clock input and a transmit start signal.

Figure 5. Basic Data Flows - SERDES Only Mode

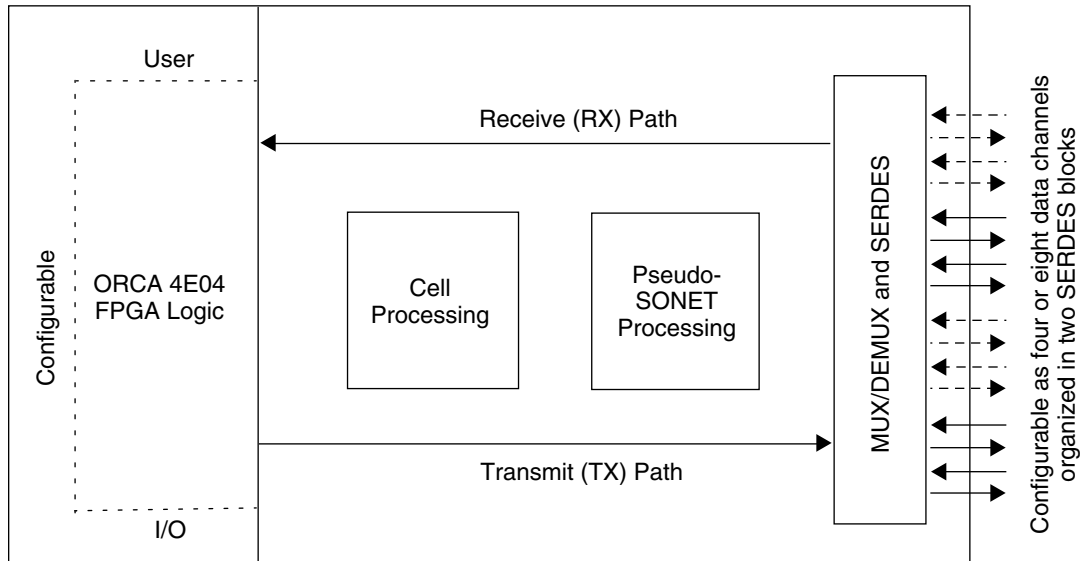
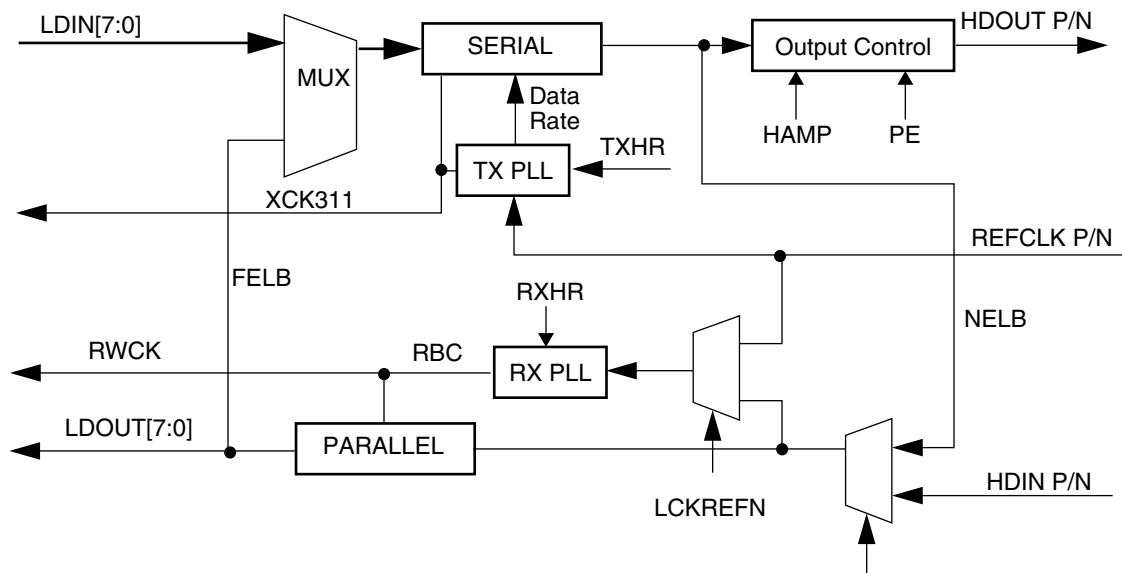

Figure 6 shows a block diagram of a single channel of the SERDES block. The transmitter section accepts either scrambled or un-scrambled data at the parallel input port. It also accepts the low-speed reference clock at the REF-CLK input and uses this clock to synthesize the internal high-speed serial bit clock. The serialized data are available at the differential CML output terminated in 86 Ω to drive either an optical transmitter, coaxial media or a circuit board/backplane.

Figure 6. SERDES Functional Block Diagram for One Channel



The receiver section receives high-speed serial data at its differential CML input port. These data are fed to the clock recovery section which generates a recovered clock and retimes the data. This means that the receive clocks are asynchronous between channels. The retimed data are deserialized and presented as an 8-bit parallel data on the output port. Two-phase receive byte clocks are available synchronous with the parallel words.

A fractional band-gap voltage generator is included on the design. An external resistor ($3.32\text{ k}\Omega \pm 1\%$), connected between the pins REXT and VSSREXT generates the bias currents within the chip. This resistor should be able to handle at least $300\text{ }\mu\text{A}$.

32:8 MUX

The MUX block is responsible for converting 32 bits of data at 77.76 MHz to 8 bits of data at 311.04 MHz. It will contain a small elastic store for clock domain transfer between the write clock from the FPGA to the divide-by-4 clock from the SERDES output clock (XCK311). It is recommended to use the clocking scheme shown later in Figure 27, Figure 28 and Figure 29 to guarantee that this elastic store will not be overrun. The 32:8 MUX is also responsible for producing the divide-by-4 clock from the SERDES output clock (XCK311) which is 311.04 MHz at a line rate of 2.488 Gbps.

In the MUX block 32-bit data synchronous to the 77.76 MHz is multiplexed to LDOUTx[7:0] synchronous to the 311.04 MHz SERDES output clock. Parallel 32-bit data can be received directly from the FPGA logic (SERDES only mode) or from the payload sub-block. Bit and byte alignment for the MUX block is shown in Figure 7.

Figure 7. Bit and Byte Alignment for MUX Block

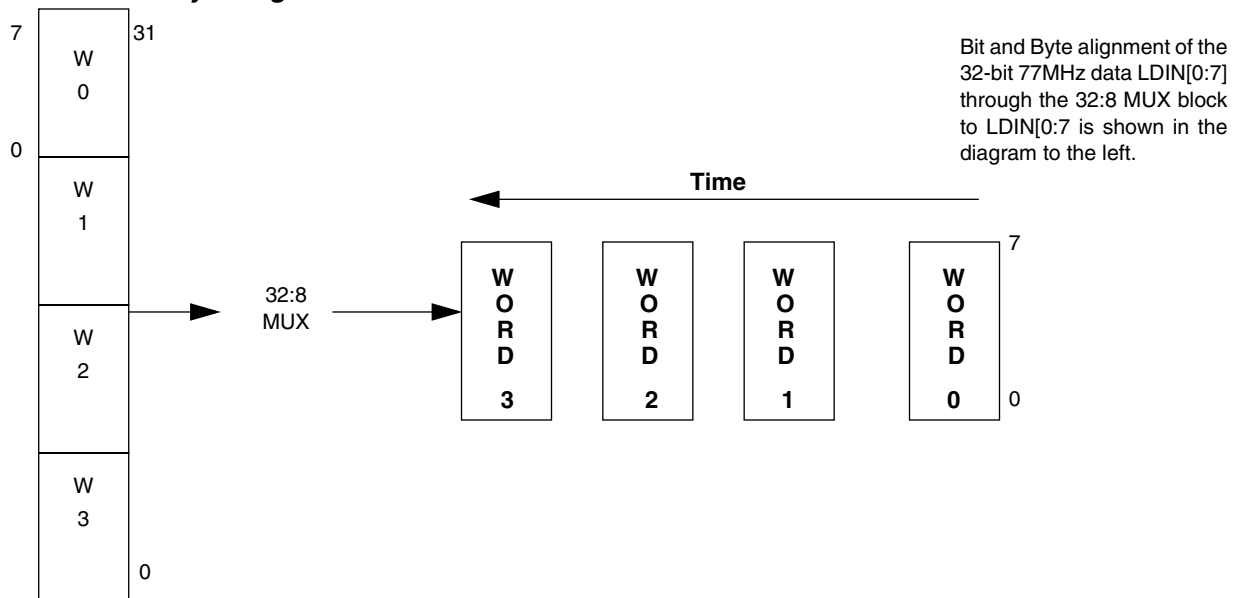

The serialized data are available at the differential CML outputs to drive either an optical transmitter, coaxial media, or circuit board/backplane. The transmitter’s CML output buffer is terminated on-chip by 86Ω to optimize the data eye as well as to reduce the number of discrete components required. The differential output swing reaches a maximum of 1.2 V_{PP} in the normal amplitude mode. A half amplitude mode can be selected via configuration register bit HAMP_xx. Half amplitude mode can be used to reduce power dissipation when the transmission medium has minimal attenuation or for testing of the integrity (loss) of the physical medium.

A programmable preemphasis circuit is provided to boost the high frequencies in the transmit data signal to maximize the data eye opening at the far-end receiver. Preemphasis is particularly useful when the data are transmitted over backplanes or low-quality coax cables which have a frequency-dependent amplitude loss. For example, for FR4 material at 2.5 GHz, the attenuation compared to the 1.0 GHz value is about 3 dB. The attenuation is a result of skin effect loss of the PCB conductor and the dielectric loss of the PCB substrate. This attenuation causes intersymbol interference which results in the closing of the data eye at the receiver.

Since this effect is predictable for a given type of PCB material, it is possible to compensate for this effect in two ways - transmitter preemphasis and receiver equalization. Each of these techniques boosts the high frequency components of the signal but transmit preemphasis is preferred due to the ease of implementation and the better power utilization. It also gives a better signal-to-noise ratio because receiver equalization amplifies both the signal and the noise at the receiver.

Applying too much preemphasis when it is not required, for example when driving a short backplane path, will also degrade the data eye opening at the receiver. In the ORSO42G5 and ORSO82G5, the degree of transmit preemphasis can be programmed per channel with two control register bits as shown in Table 4. The high-pass transfer function of the preemphasis circuit is given by the following equation, where the value of a is shown in Table 4.

$$H(z) = (1 - az^{-1})$$

Table 4. Preemphasis Settings

| PE1 | PE0 | Amount of Preemphasis (a) |
|-----|-----|------------------------------|
| 0 | 0 | 0% (No Preemphasis, Default) |
| 0 | 1 | 12.5% |
| 1 | 0 | 12.5% |
| 1 | 1 | 25% |

SERDES Receive Path

The receiver section receives high-speed serial data at its differential CML input port. These data are fed to the clock recovery section which generates a recovered clock and retimes the data. Each SERDES receive channel has its own PLL and this means that the receive clocks are asynchronous between channels. This also enables each receive channel to either operate in half-rate or full-rate mode. The retimed data are deserialized and presented as a 8-bit parallel data on the output port. Two-phase receive byte clocks (RBC0 and RBC1) are available synchronous with the parallel words. RBC0 has its rising edge aligned to the center of the receive byte. RBC1 has its falling edge aligned to the center of the receive byte. The 8-bit data (LDOUT) as shown in Figure 8, changes on a single clock edge (rising edge of RBC0 or falling edge of RBC1).

Figure 8. SERDES Receive Path Timing

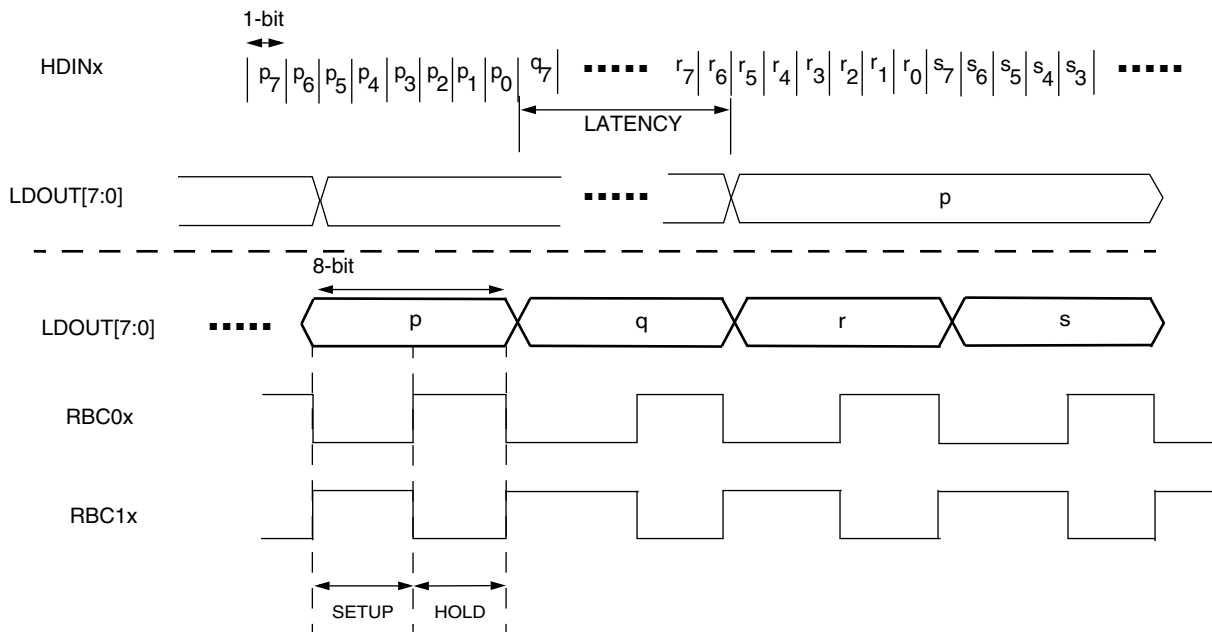

The receive PLL has two modes of operation as follows: lock to reference and lock to data with retiming. The control bit LCKREFN_xx selects the operating mode. When setup to lock to data and no data or invalid data are present on the HDINP and HDINN pins, the receive VCO will not lock to data and its frequency can drift outside of the nominal ± 100 ppm range. Under this condition, the receive PLL will lock to REFCLK for a fixed time interval and then will attempt to lock to receive data. The process of attempting to lock to data, then locking to clock will repeat until valid input data exists. The default mode is lock to reference.

The recovered byte clock (RBC0) is only centered on the data when operating in the lock to data mode. In the lock to reference mode, RBC0 is not centered on the data and may not capture the correct byte value.

The SERDES receives MSB first and LSB last. Hence LDOUTx[7] is the bit that is received first and LDOUTx[0] is the bit that is received last.

8:32 DEMUX

The SERDES provides an eight bit data bus, and a clock, RBC0, which has a rising edge which occurs in the center of the valid data region. The DEMUX block will create one 32-bit data word from the single 8-bit bus. The DEMUX block will also provide a 77.76 MHz clock (divide-by-4 clock of RBC0) called RWCKxx to the rest of the logic blocks such as the framer, descrambler, cell extractor and FIFOs.

Figure 9. 8:32 DEMUX Block

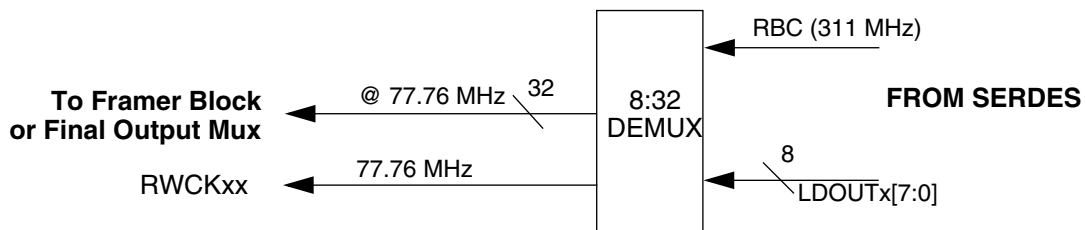

In the DEMUX block, LDOUTx[7:0] is demultiplexed to a 32-bit data bus synchronous to the derived 77.76 MHz clock generated by dividing the 311.04 MHz clock by four. The 77.76 MHz clock is used by the remaining embedded blocks, as well as being fed to the FPGA. Receive data from the DEMUX block is unframed. Parallel data can be sent directly to the FPGA logic (SERDES only mode) or to the framer block for processing. Bit and byte alignment for the DEMUX block is shown in Figure 10.

Figure 10. Bit and Byte Alignment for DEMUX Block

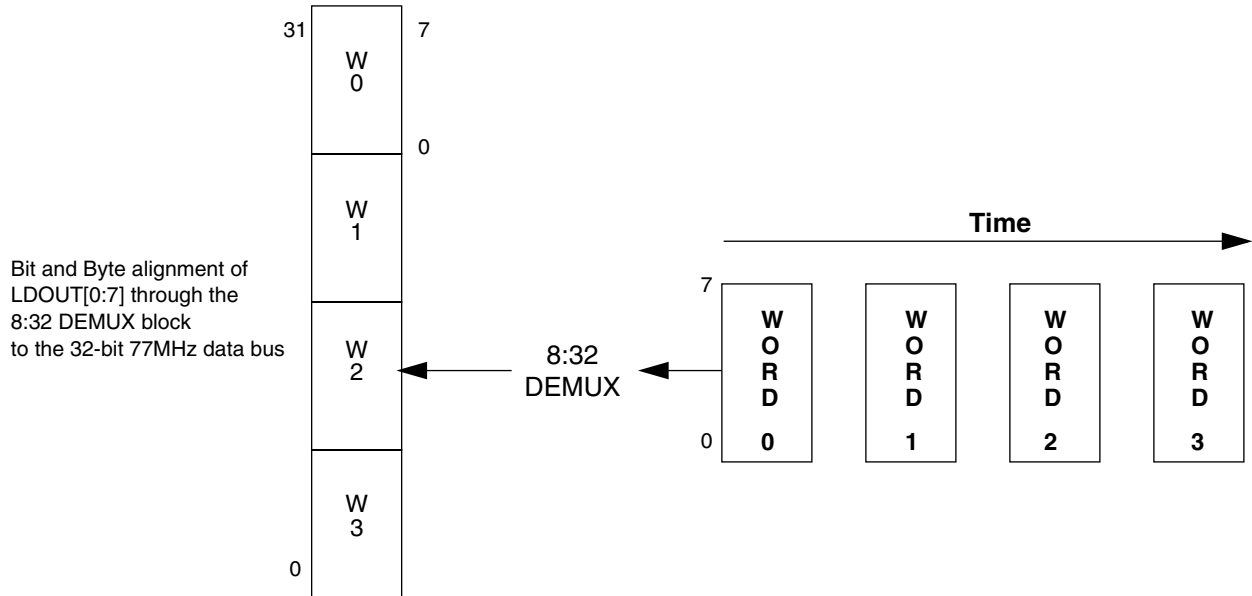

SONET Mode Operation – Detailed Description

The following sections describe the data processing performed in the SONET logic blocks. The basic data flows in the SONET Mode are shown in Figure 11. At a top level, the descriptions are separated into processing in the transmit path (FPGA to serial link) and processing in the receive path (serial link to FPGA). In general, the descriptions in the next sections are written to describe SONET mode operation, although some of the “SONET logic blocks” are also used in cell mode operation. The various processing options are selected by setting bits in control registers and status information is written to status registers. Both types of registers can be written and/or read from the System Bus. Memory maps and descriptions for the registers are given in Table 21 through Table 36.

Figure 11. Basic Data Flows - SONET Mode

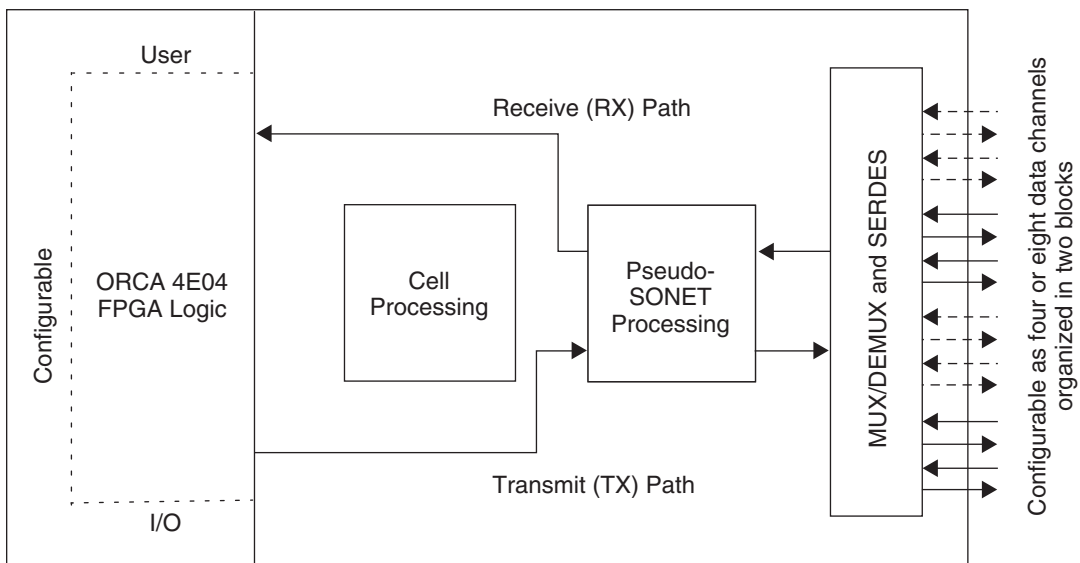

In the SONET mode, the transmit block receives 32-bit wide data from the FPGA (DINxx) on each of its channels along with a frame pulse (DINxx_FP) per channel and a transmit clock (TSYCLKxx). Typically this will represent a STS-48 stream on each link. The data are first passed through a TOH block which will generate all the timing pulses that are required to isolate individual overhead bytes (e.g., A1, A2, B1, D1-D3, etc.). The timing pulse gener-

ation will be based on the system frame pulse (DINxx_FP) received from the FPGA logic, hence it is recommended that, for multi-channel alignment at the receiver, the frame pulses for the channels in an alignment group be synchronized. The data are then scrambled before being sent to the SERDES.

In the receive direction, the two SONET blocks process the receiving channels which can be treated as STS-192 streams or as independent STS-48 streams. The clocks for the received data are recovered from the received serial data streams and a serial to parallel conversion is performed on the data. The frame format of the incoming data are reconstructed (optional). The data then is descrambled using the standard SONET polynomial and a B1 parity error check is performed on the data from the previously transmitted frame.

In the SONET mode, the incoming serial data streams can be aligned by groups of two, four or, in the ORSO82G5, eight. When doing multichannel alignment of two or more data streams, the receiver can handle the data streams with frame offsets of up to 18 78MHz clock cycles due to timing skews between cards and along backplane traces or other transmission medium. For multichannel alignment capability to operate properly, it should be noted that while the skew between channels can be very large, they must operate at the exact same frequency (0 ppm frequency deviation), thus requiring that the transmitters sourcing the data being received be driven by the same clock source. It is highly recommended that the frame pulses, DINxx_FP, for all links in an alignment group be synchronized. (See Table 11 and Table 12 for details of the core/FPGA transmit direction signal assignments.)

The received data streams are processed and passed to the FPGA logic as 32-bit words. In SONET mode, DOUTxx[31:0] carries the 32 bit data from the alignment FIFO of the respective channel and an accompanying frame pulse, DOUTxx_FP. Other core/FPGA carries miscellaneous information such as OOF, BIPERR, and SPE indicator. (See Table 13 and 14 for details of the core/FPGA receive direction signal assignments.)

Basic SONET Frame Format

An STS-N frame can be broadly divided into the Transport OverHead (TOH) and the Synchronous Payload Envelope (SPE) areas. The TOH comprises of bytes that are used for framing, error detection and various other functions. The start of the SPE can begin at any point in a SONET frame. The start of the SPE is determined using the pointer bytes located in the TOH. The basic STS-1 frame is shown in Figure 12. Higher rate STS_N signals are created by byte interleaving N STS-1 signals. Some TOH bytes have slightly different functions in STS-N frames than in the basic STS-1 frame. The ORSO42G5 and ORSO82G5 offer two options for processing the TOH bytes, as discussed in a later section.

Figure 12. STS-1 Frame Format

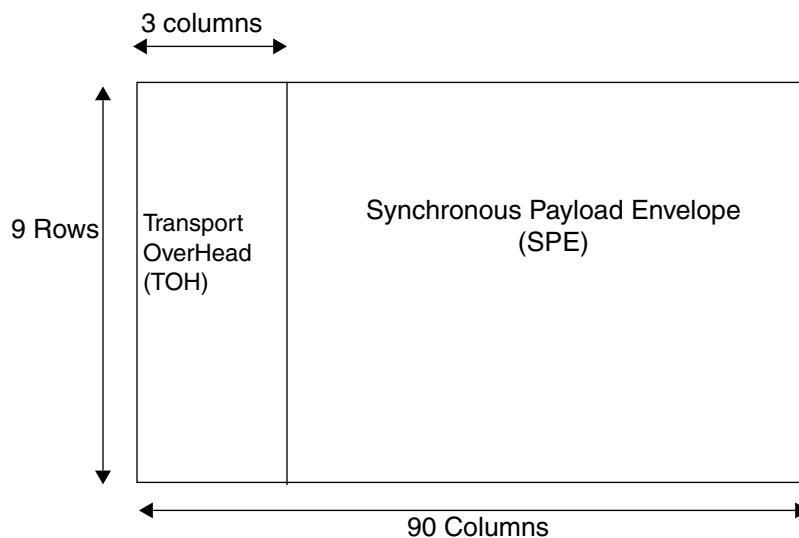

Supported Data Formats

The ORSO42G5 and ORSO82G5 in the SONET mode support the following formats:

- Single OC-48 on each of the channels at a bit rate of 2.488 Gbps.
- OC-192 received in block OC-48 format on four channels at a combined rate of 9.952 Gbps.

The ORSO42G5 and ORSO82G5 SERDES will operate at the OC-12 rate of 622 MHz. For this rate, REFCLK is set to 77 MHz and the SERDES is used in half rate mode. However the embedded core SONET framing/processing logic is fixed at the OC-48 rate and therefore can not talk directly with standard STS-12 devices. In order to interoperate with standard STS-12 devices, the user must bypass the SONET functionality in the ORSO embedded core (SERDES-only mode) and implement all framing, TOH and scrambling/descrambling functionality in FPGA logic.

Figure 13 reveals the byte-ordering of the individual STS-48 streams. STS-192 is supported but it must be received in the block STS-48 format as shown in Figure 14. Each OC-48 stream is composed of byte-interleaved OC-1 data as described in GR-253 standard. Note that the SPE data is not touched by the core.

Figure 13. Byte Ordering of Input/Output Interface in STS-48 Mode

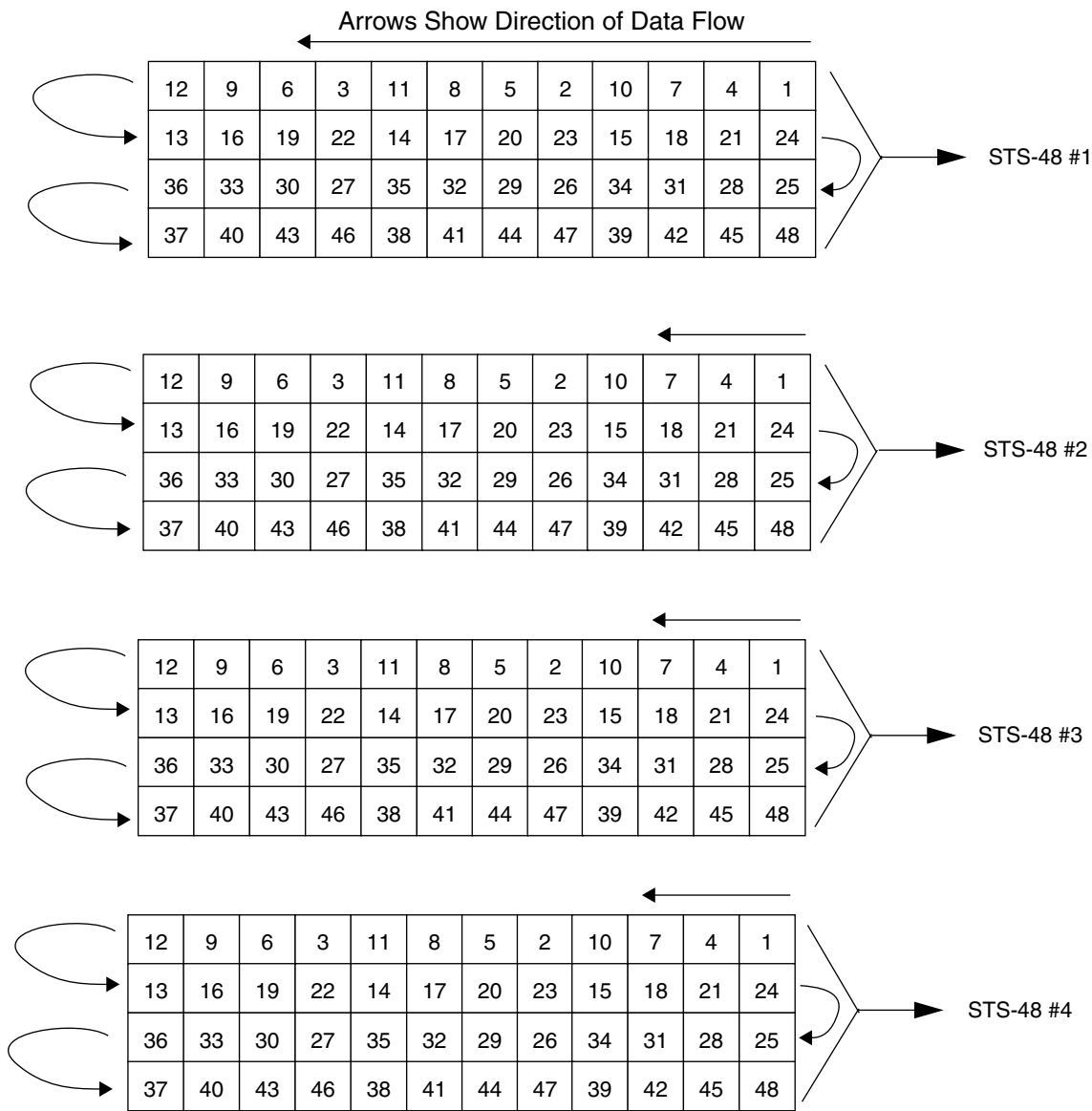
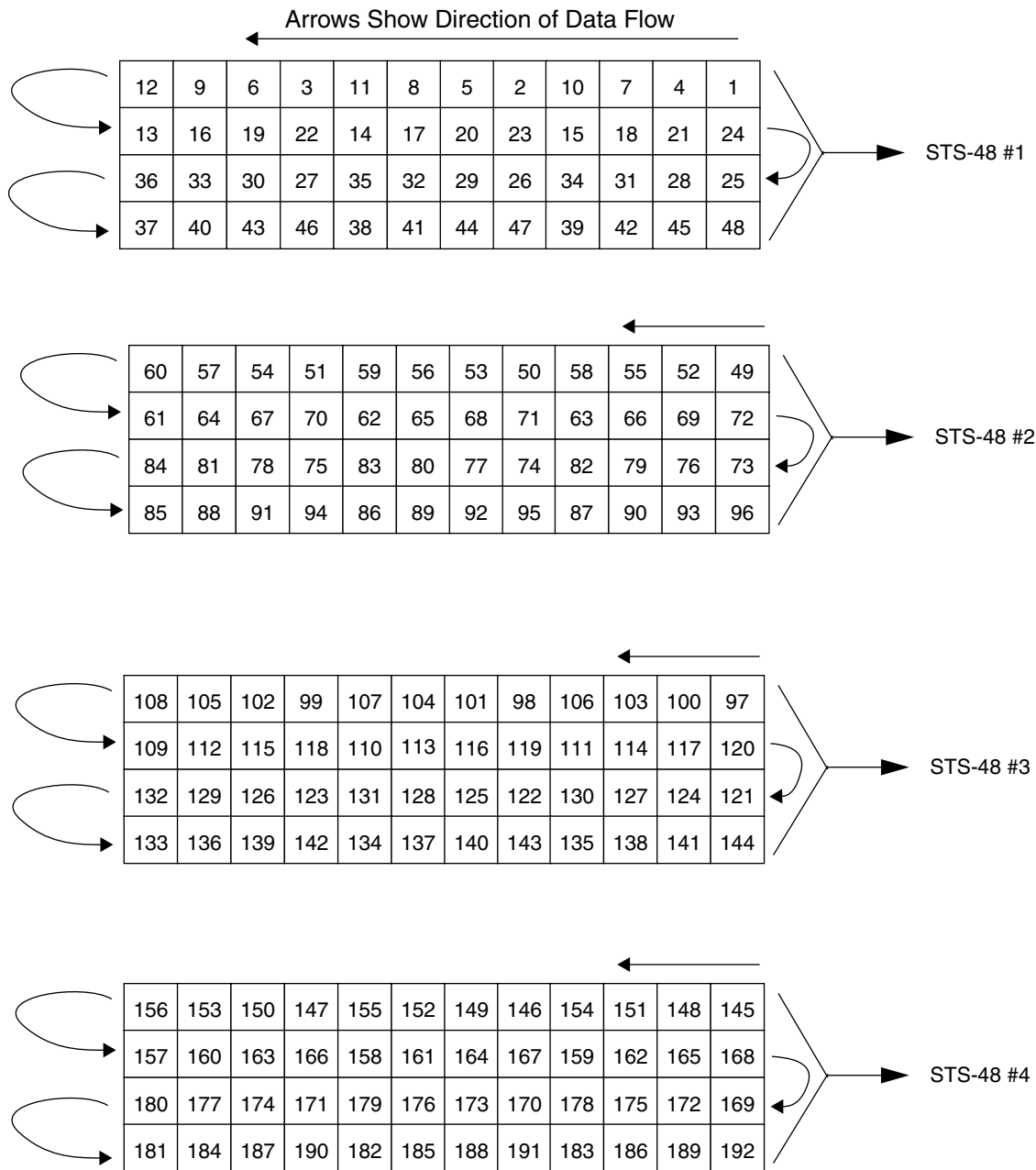

Figure 14. Byte Ordering of Input/Output Interface in STS-192 (Block STS-48) Mode



STS-192 in
block STS-48 format

SONET TOH Byte Definitions

The Transport OverHead bytes of the SONET frame can be used for in-band configuration, service, and management since it is carried along the same channel as data. In the ORSO42G5 and ORSO82G5 in-band signaling can be efficiently utilized, since the total cost of overhead is only 3.3%. The overhead bytes in an STS-1 header are shown in Table 15 (The path overhead bytes are in the SPE.)

Figure 15. SONET Overhead Bytes

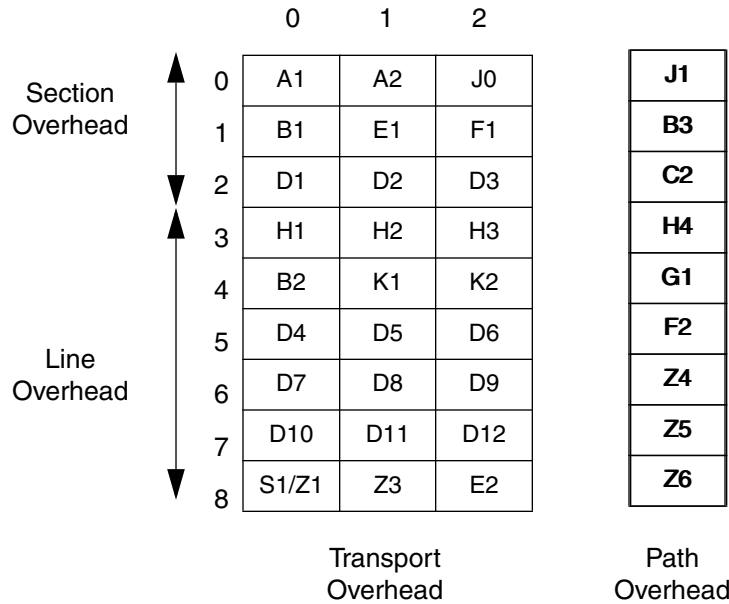

When used in true SONET applications, all or most TOH bytes will be generated in the FPGA logic or by an external device. Two modes are provided for this application – transparent and AUTO_SOH. In transparent mode all bytes from the FPGA logic are passed through unchanged.

In AUTO_SOH mode the embedded core inserts the A1/A2 framing bytes, performs the B1 calculation and inserts the B1 byte. A1/A2 and B1 insertion can be independently enabled. This avoids the need to do SONET scrambling in the FPGA logic. All other bytes are passed through unchanged from the FPGA logic as in transparent mode.

When used for applications that transfer non-SONET data, an AUTO_TOH mode is provided. In this mode, all of the overhead bytes are set by the embedded core. Most of the bytes are set to zero. At the receive side, all of the TOH bytes except those set to a non-zero value can be ignored in the AUTO_TOH mode.

The TOH bytes have the following functions in true SONET applications.

Section Overhead Bytes:

- A1, A2 – These bytes are used for framing and to mark the beginning of a SONET frame. A1 has the value 0x F6 and A2 has the value 0x28.
- J0 -Section Trace Message – This byte carries the section trace message. The message is interpreted to verify connectivity to a particular node in the network.
- B1 - Section Bit Interleaved Parity (BIP-8) byte – This byte carries the parity information which is used to check for transmission errors in a section. The computed parity value is transmitted in the next frame in the B1 position. It is defined only for the first STS-1 of a STS-N signal. The other bytes have a default value of 0x00.

- E1 - Section order wire byte - This byte carries local orderwire information, which provides for a 64 Kbps voice channel between two Section Termination Equipment (STE) devices.
- F1 - Section user channel byte - This byte provides a 64 Kbits/s user channel which can be used in a proprietary fashion.
- D1, D2, D3 - Section Data Communications Channel (SDCC) bytes - These bytes provide a 192 Kbits/s channel for transmission of information across STEs. This information could be for control and configuration, status monitoring, alarms, network administration data etc.

Line Overhead Bytes:

- H1, H2 - STS Payload Pointers (H1 and H2) - These bytes are used to locate the start of the SPE in a SONET frame. These two bytes contain the offset value, in bytes, between the pointer bytes and the start of the SPE. These bytes are used for all the STS-1 signals contained in an STS-N signal to indicate the individual starting positions of the SPEs. They bytes also contain justification indications, concatenation indications and path alarm indication (AIS-P).
- H3 - Pointer Action Byte (H3) - This byte is used during frequency justifications. When a negative justification is performed, one extra payload byte is inserted into the SONET frame. The H3 byte is used to hold this extra byte and is hence called the pointer action byte. When justification is not being performed, this byte contains a default value of 0x00.
- B2 - Line Bit-Interleaved Parity code (BIP-8) byte - This byte carries the parity information which is used to check for transmission errors in a line. This is a even parity computed over all the bytes of the frame, except section overhead bytes, before scrambling. The computed parity value is transmitted in the next frame in the B2 position. This byte is defined for all the STS-1 signals in an STS-N signal.
- K1, K2 - Automatic Protection Switching (APS channel) bytes - These bytes carry the APS information. They are used for implementing automatic protection switching and for transmitting the line Alarm Indication Signal (AIS-L) and the Remote Defect Indication (RDI-L) signal.
- D4 to D12 - Line Data Communications Channel (DCC) bytes - These bytes provide a 576 Kbps channel for transmission of information.
- S1 - Synchronization Status - This byte carries the synchronization status of the network element. It is located in the first STS-1 of an STS-N. Bits 5 through 8 of this byte carry the synchronization status.
- Z1 - Growth - This byte is located in the second through Nth STS-1s of an STS-N and are allocated for future growth. An STS-1 signal does not contain a Z1 byte.
- M0 - STS-1 REI-L - This byte is defined only for STS-1 signals and is used to convey the Line Remote Error Indication (REI-L). The REI-L is the count of the number of B2 parity errors detected by an LTE and is transmitted to its peer LTE as feedback information. Bits 5 through 8 of this byte are used for this function.
- E2 - Orderwire byte - This byte carries for line orderwire information.

SONET Mode Transmit Path

The transmit block performs the following functions in SONET mode:

- A1 and A2 insertion and optional corruption
- BIP-8 parity calculation, B1 byte insertion and optional corruption. (B1 byte is inverted.)
- Performs RDI insertion (K2 byte is set to "0000 0110").
- Scrambling of outgoing data with optional scrambler disabling.

In either STS-192 or STS-48 mode, each link operates at an STS-48 rate.

TX Frame Processor

The Tx_Frame_Processor (TFP) block is the primary data processing block in the both SONET mode and cell mode. It organizes the cell data into a SONET frame before sending it to the SERDES. The TFP is on the TSY-CLKxx clock domain (77.76 MHz). In SONET mode, the 32-bit data comes from the FPGA interface. (In cell mode the data comes from the cell processing block as described in the cell mode section) The TFP block contains three major sub-blocks: payload block, TOH block and scrambler block. The interfaces for the TFP block are shown in Figure 16.

Figure 16. TX Frame Processor (TFP) Block Diagram

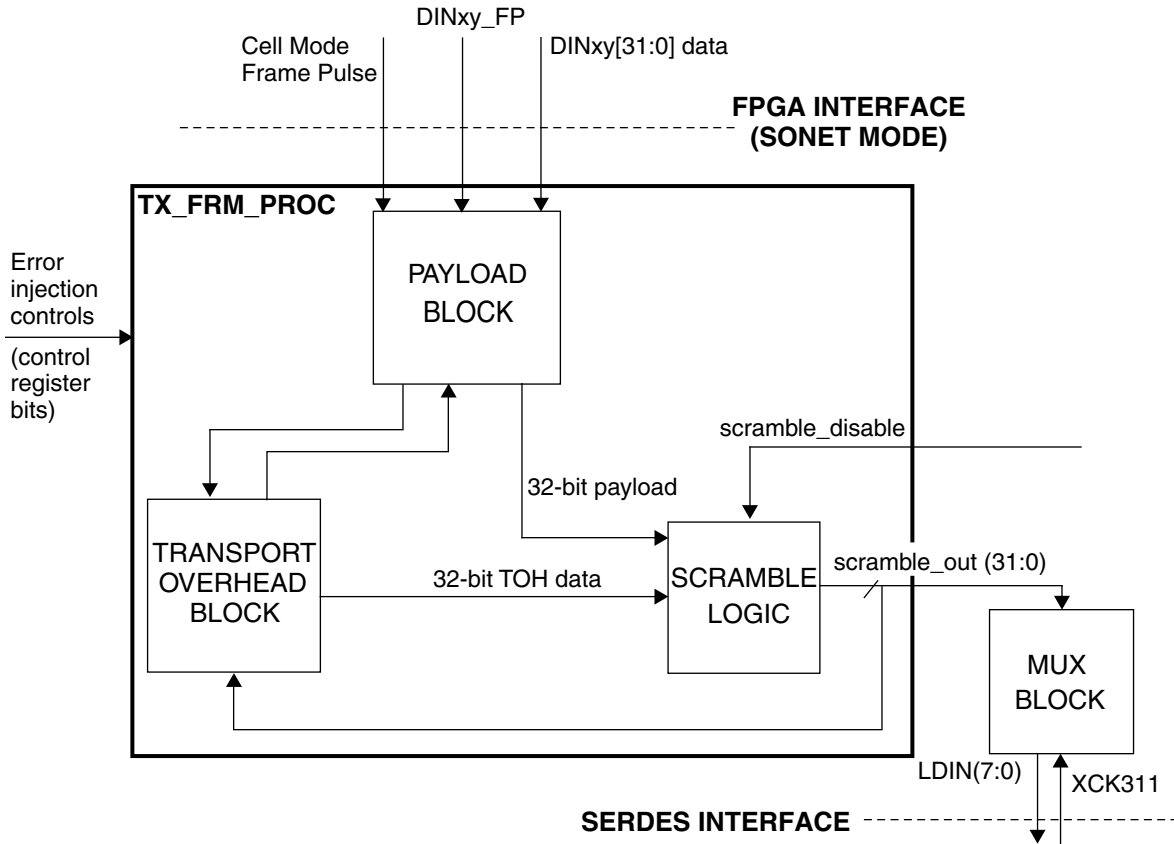

Payload Sub-block

The Payload sub block is activated by the cell mode frame pulse (cell mode) or DINxx_FP from FPGA (SONET mode). A pulse on this signal indicates the start of a frame.

In SONET mode, only two types of data bytes are in each frame:

- TOH bytes
- SPE data bytes

There are $N \times 3$ ($N = 48$) bytes of TOH per row and there are a total of 9 rows in a SONET frame. The rest of the bytes in each row are SPE data bytes in SONET mode.

TOH Sub-block

This block is responsible formatting the 144 (48×3) bytes of TOH at the beginning of each row of the transport frame. All TOH bytes may be transmitted transparently from the FPGA logic using the transparent mode. Alternatively, some or all TOH bytes may be inserted by the TOH block (AUTO_SOH and AUTO_TOH mode). The TOH data is transferred across the FPGA/core interface as 32-bit words, hence 36 clock cycles (12×3) are needed to transfer a TOH row. TOH insertion is controlled by software register bits as shown in the Register Map tables.

Table 5. Inserted TOH Values (All 0x) in AUTO_SOH Mode

| | | |
|---|---------|-----|
| A1 = F6 | A2 = 28 | J0 |
| B1 = calculated, 1st. STS-1 B1 = 00, other STS-1s | E1 | F1 |
| D1 | D2 | D3 |
| H1 | H2 | H3 |
| B2 | K1 | K2 |
| D4 | D5 | D6 |
| D7 | D8 | D9 |
| D10 | D11 | D12 |
| S1 | M1 | E2 |

The TOH values inserted in AUTO_SOH mode are shown in Table 5. If a specific value is not listed in the table, the bytes are transmitted transparently from the FPGA logic as in the transparent mode. Optionally K2 can be inserted by the core using the FORCE_RDI_xx control register bits. A1/A2 and B1 insertion can be independently enabled.

The TOH values inserted in AUTO_TOH mode are shown in Table 6. The values are for all STS-1s in the STS-48 frame unless noted otherwise.

Table 6. Inserted TOH Values (All 0x) in AUTO_TOH Mode

| | | |
|---|---|---|
| A1 = F6 | A2 = 28 | J0 = STS-1 ID, every 4th. STS-1 J0 = 00, other STS-1s |
| B1 = calculated, 1st. STS-1 B1 = 00, other STS-1s | E1 = 00 | F1 = link number, 1st. STS-1 F1 = 00, other STS-1s |
| D1 = 00 | D2 = 00 | D3 = 00 |
| H1 = 62, 1st. STS-1 H1 = 93 other STS-1s | H2 = 0A, 1st. STS-1 H2 = FF other STS-1s | H3 = 00 |
| B2 = 00 | K1 = 00 | K2 = 06 for RDI, K2 = 00 otherwise, 1st. STS-1 K2 = 00, other STS-1s |
| D4 = 00 | D5 = 00 | D6 = 00 |
| D7 = 00 | D8 = 00 | D9 = 00 |
| D10 = 00 | D11 = 00 | D12 = 00 |
| S1 = 00 | M1 = 00 | E2 = 00 |

The TOH block can perform A1/A2 corruption by inverting the A1/A2 bytes and also can force B1 errors by inverting the B1 byte. A RDI can be injected by forcing the K2 byte to "00000110". In SONET mode, all TOH bytes can be transparently sent from the FPGA as an option. Error and RDI insertion are controlled by software register bits as shown in the Register Map tables.

Scramble Sub-block

The scrambler scrambles the incoming 32-bit data using the standard SONET polynomial $1 + x^6 + x^7$. The scrambler can be disabled by a software register bit.

32:8 MUX

The MUX block is responsible for converting 32 bits of data at 77.76 MHz to 8 bits of data at 311.04 MHz. It will contain a small elastic store for clock domain transfer between the write clock from the FPGA to the divide-by-4 clock from the SERDES output clock (XCK311). It is recommended to use the clocking scheme shown to guaran-

tee that this elastic store will not be overrun. The 32:8 MUX is also responsible for producing the divide-by-4 clock from the SERDES output clock (XCK311) which is 311.04 MHz at a line rate of 2.488 Gbps.

SONET Mode Transmit Timing

Figure 17 shows the transmit clocks and a recommended clocking scheme. As shown, TCK78[A,B] can be used to the source TSYCLKxx signals. It is a requirement that TSYCLKxx be frequency locked to the corresponding TCK78[A,B] clock signal derived from REFCLK_[A:B].

Figure 17. Transmit Clocking Diagram in SONET Mode

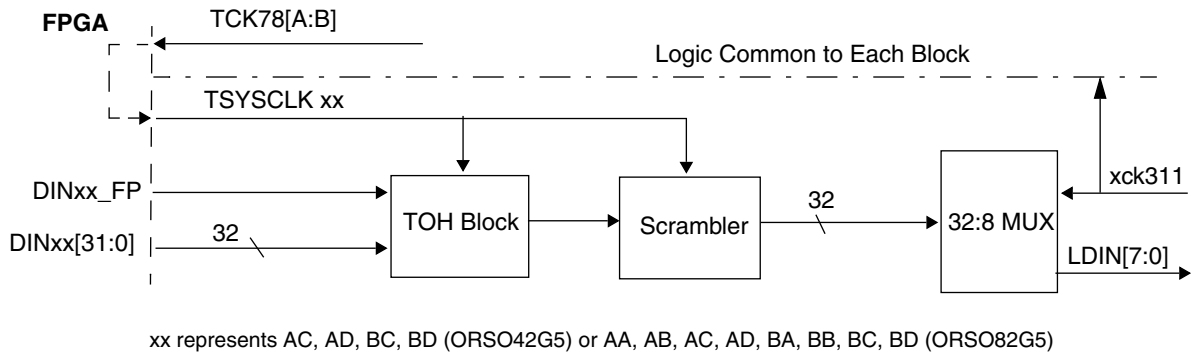

- When operating in SONET mode, the entire SONET frame is sent by the user. Optionally the TOH bytes can be overwritten by the transmit block (AUTO_SOH or AUTO_TOH) before sending to scrambler and SERDES block.
- Each SONET frame is 125 μs given a 155.52MHz reference clock.
- The frame starts with 36 clock cycles (77.76 MHz) of TOH followed by 1044 clock cycles of SPE, followed by 36 clock cycles of TOH, 1044 cycles of SPE etc. for all nine rows.

Figure 18. Transmit SONET Mode

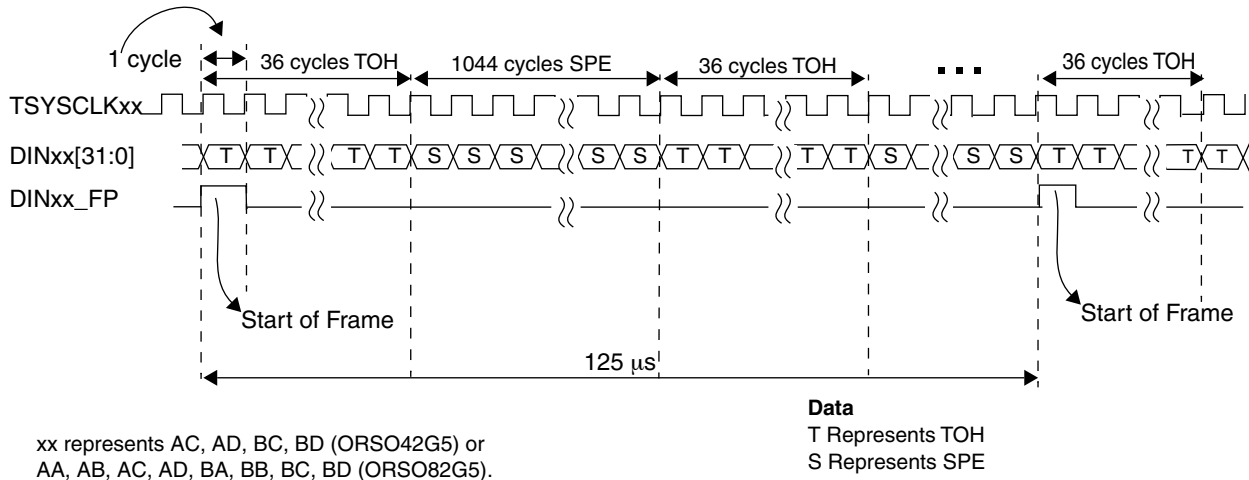

SONET Mode Receive Path

The receiver block receives a byte from the SERDES blocks for each of the channels. The byte arrives at the receiver block at 311.04 MHz. This data are not frame-aligned or word aligned. The data are first passed through a divide-by-4 DEMUX which produces a 32-bit word at 77.76 MHz. Data from the DEMUX is then passed through a framer which aligns and frames the data. Data are processed based on cell mode or SONET mode.

In the SONET mode, the descrambled data are sent to an alignment FIFO that performs lane-to-lane deskew and aligns data within an alignment group to the RSYCLK clock domain. Both the write and read clocks to the align-

ment FIFO should be at exactly the same frequency (0 ppm difference), i.e., from a common clock source. Later in this data sheet, Figures 22, 23, 27, 28, and 29 show the recommended clocking scheme to adhere to this requirement. In addition, supervisory features such as BIP error check, OOF check, RDI monitoring and AIS-L insertion during OOF are also implemented. All the supervisory features are controlled through programmable register bits.

Framer

The frame and byte phase of the bits within the 32-bit word from the DEMUX is random. For each of the STS-48 channels, the framer outputs 4 bytes (32-bits) that are frame-aligned and a frame pulse that is one clock-wide. The transition from A1 bytes to A2 bytes should happen on a 32-bit boundary. If any two consecutive bytes of the 4-byte-aligned word match the A1-A2 pattern (0xF628 in standard SONET framing), the byte-aligned word will be byte rotated to achieve frame alignment.

Framer State Machine (FSM)

The framer FSM is responsible for detecting the in-frame and Out-Of-Frame status of the incoming data and sends out alarms (interrupts) on Out-Of-Frame (OOF). The framer is a pseudo-SONET framer in the sense that it does not support LOF or SEF detect-alarm signal as specified in the GR-253 standard.

The framer has a fast frame mode where a single good framing pattern can cause the framer state machine to go the “in_frm” state and a single bad frame can cause the state machine to declare “OOF” (See Fig. 19). The fast frame mode can be set by the software register bit, FFRM_EN_xx.

The FSM is a four byte framer and searches for the framing pattern based on the 32-bit words. Accordingly, the framing pattern is four A1 bytes (F6,F6,F6,F6) followed by four A2 bytes (28,28,28,28).

The framer FSM comes out of reset in the “OOF” state with the OOF alarm set. The framer goes in frame if it finds 2 consecutive frames with the desired framing bytes and goes out of frame if it finds 4 consecutive frames with at least one framing bit error in each frame. Frame timing is also synchronized based on the STS-48 row and column counters. This corresponds to SONET specification that it will take two consecutive valid framing patterns to frame to an incoming signal. Outside the “OOF” state, the OOF alarm output is low.

Figure 19. Transmit Clocking Diagram in SONET Mode

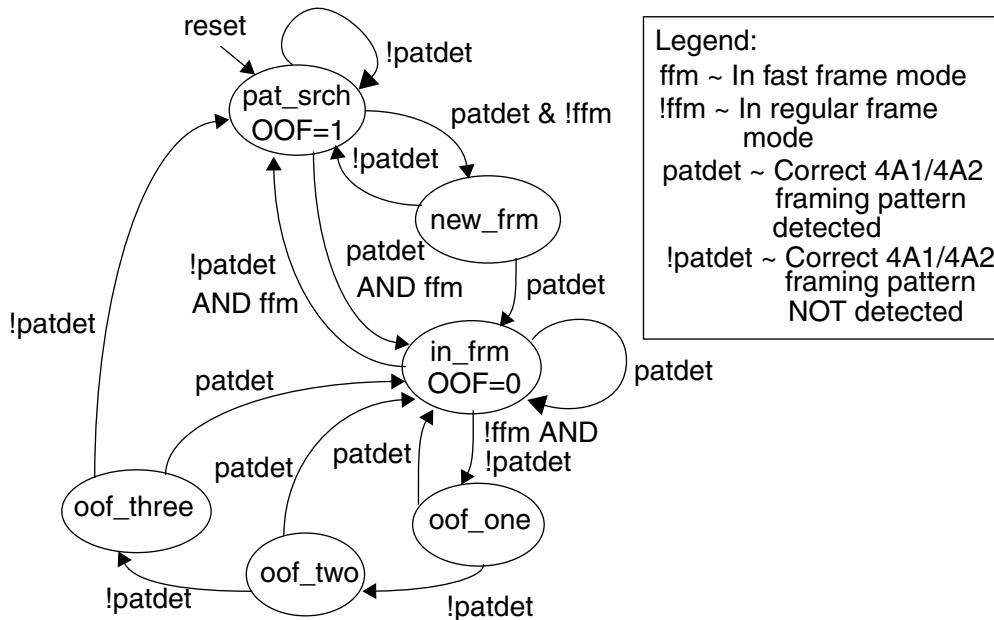

Section (B1) BIP-8 Calculator

The section BIP-8 B1 byte in a given STS-N frame contains the scrambled BIP value for all scrambled bytes of the previous frame. Except for the A1,A2 and J0 section overhead bytes, all bytes in a frame are scrambled. The Section (B1) BIP-8 is calculated as the even parity of all bits in the current STS-48 frame. This value is compared to the Section Overhead B1 byte of the next frame. B1 error counters are available that monitors the number of B1 errors on a per-channel basis. A B1 parity error flag is also generated as a software alarm bit.

Descrambler

The data from the framer is descrambled using the SONET/SDH standard generator polynomial $1 + x^6 + x^7$. The descrambling is performed in parallel on each 32-bit word per channel, synchronized to the frame pulse and can be disabled through the software register bit.

RDI (Remote Defect Indicator) Monitor

The line RDI (RDI-L) is monitored through bits 2-0 of the K2 byte. Within the 32-bit descrambled data, a pattern of "110" on bits 26-24 will indicate a RDI-L status. RDI-L must be detected in two consecutive frames before an RDI alarm register bit is set. If `fast_frame_mode` is enabled, then the RDI alarm register bit will be set if RDI-L is detected in one frame.

Receive FIFO

Clock domain transfers and multi-link de-skew are one of the most critical parts of this device. The main clock domain transfer for the datapath is handled by the receive FIFO. For each link, there are two FIFOs. A 24 x 33 FIFO is used in SONET mode.

The use of the FIFO is controlled by configuration bits.

- Data can be sent from the descrambler directly to the FPGA bypassing the alignment FIFO. Data from each channel will have an associated clock (RWCKxx at 77.76 MHz). Each channel will also provide a FP and SPE indicator along with the data. Descrambling can be inhibited through the `DSCR_INH_xx` control bit.
- Data can be sent directly from the 8:32 DEMUX block to the FPGA bypassing the alignment FIFO and SONET framer and descrambler. Data from each channel will have an associated clock. No SPE or FP indicator is provided with the data.

Receive FIFO in SONET mode

The receive FIFO used in SONET mode will allow for an inter-link skew of about 300 ns (24 x 32 = 768 bits, 400 ps per bit gives 307 ns). The FIFO is written at 77.76 MHz and read at 77.76 MHz. Once frame synchronization has occurred, the write control logic will cause data to be written to the memory. The write control block is required to insure that the word containing the first A1 byte is written to the same location (address 0) in the FIFO. The synchronization algorithm issues a sync pulse and sync error signals to the read control block based on the alignment option chosen. This sync pulse will coordinate the reading of the FIFOs.

The read control logic synchronizes the reading of the FIFO for the streams that are to be aligned. The block begins reading when the FIFO sync sub block signals that all of the applicable A1s with the appropriate margin have been written to the FIFO. All of the read blocks to be synchronized begin reading at the same time and same location in the memory (address 0). The block also takes the difference between the write and read address to indicate the relative skews between the links. If this difference exceeds a certain limit (programmable), then an alarm (alignment overflow) is provided to the register interface.

Multi-channel Alignment in SONET Mode – ORSO42G5

The alignment FIFO allows the transfer of all data to a common clock. The FIFO sync block allows the system to be configured to allow the frame alignment of multiple slightly varying data streams. This optional alignment ensures that matching SERDES streams will arrive at the FPGA end in perfect data sync. It is important to note that for all aligned channels in a group, the SERDES transmitters on the other side of the high-speed link must all be transmitting data at exactly the same frequency (0 ppm difference), i.e., using a common clock source.

The ORSO42G5 has a total of four channels (two per SERDES block). The incoming data of these channels can be synchronized in several ways, or they can be independent of one other. Two channels within a SERDES can be

aligned together, channels C and D to form a pair as shown in Figure 20. Alternately, all four channels in the SERDES blocks can be aligned together to form a communication channel with a bandwidth of 10 Gbps as shown in Figure 21.

Figure 20. Twin Channel Alignment – ORSO42G5

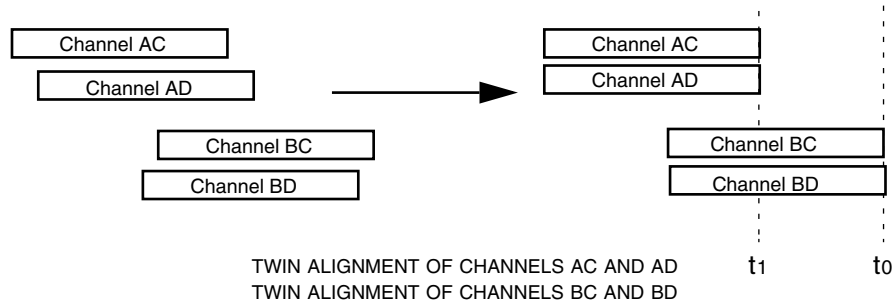
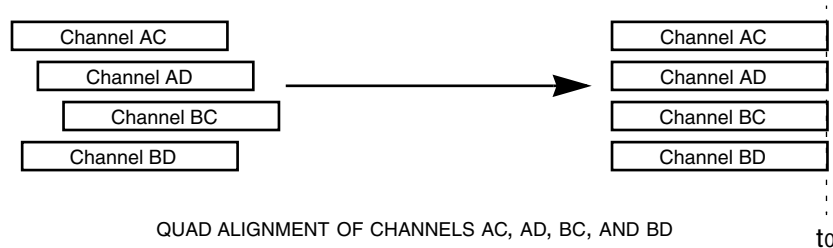

Figure 21. Quad Channel Alignment of SERDES Blocks A and B – ORSO42G5



Individual channels within an alignment group can be disabled (i.e., powered-down) without disrupting other channels. Note that the SERDES channel that is powered down can not be the source of the RSYSCLKxx that is clocking the read side of the alignment FIFO. When a disabled channel becomes active as part of an alignment group, the group may need to be re-aligned. Then the whole group needs to be resynched. This would only need to occur if the transmitting frame pulse for the new link is different from the rest of the group.

Each channel is provided with a 24 word x 33-bit FIFO. The FIFO can perform two tasks: (1) to change the clock domain from receive clock to a clock from the FPGA side, and (2) to align the receive data over 2 or 4 channels. This FIFO allows a timing budget of 307 ns that can be allocated to skew between the data lanes and for transfer to the common clock. The input to the FIFO consists of 32-bit data and a frame pulse that indicates the start of a frame (or A1A2 framing bytes). This frame pulse is used to synchronize multiple channels within an alignment group.

If a channel is not in any alignment group, the FIFO control logic will set the FIFO-write-address to the beginning of the FIFO, and will set the FIFO-read-address to the middle of the FIFO at the first assertion of frame pulse after reset or after the resync command.

The RX_FIFO_MIN register bits can be used to control the threshold for minimum unused buffer space in the alignment FIFOs between read and write pointers before OVFL status is flagged. The synchronization algorithm consists of a down counter which starts to count down by 1 from its initial value of 18 (decimal) when a frame pulse from any channel within an alignment group has been received. The OOS alarm indicates the FIFO is out-of sync and the channel skew exceeds that which can be handled by the FIFO. Once the frame pulse for all channels within the alignment group have been received, the count is decremented by 2 until 0 is reached. Data are then read from the FIFOs and output to the SPE generator before being sent to the FPGA.

For every alignment group, there is an OVFL and OOS status register bit. The OOS bit is flagged when the down counter in the synchronization algorithm has reached a value of 0 and frame pulse from all channels within an alignment group have not been received. The OVFL bit is flagged when the read address at the time of receiving a

frame pulse, is less than the minimum threshold set by RX_FIFO_MIN. In the memory map section OOS is referred to as SYNC2_[A2,B2]_OOS, SYNC4_OOS. OVFL is referred to as SYNC2_[A2,B2]_OVFL, SYNC4_OVFL.

Receive Clocking for Multi-channel Alignment – ORSO42G5

There are a total of seven clocks for the receive path, from FPGA to the core. The two used in SONET mode are RSYSCLKA2 (for block A), and RSYSCLKB2 (for block B). The following diagrams show the recommended clock distribution approaches for SONET mode multi-channel alignment modes. Cell mode alignment is discussed in the section describing the Input Port Controller (IPC.)

SONET Mode Twin Alignment – ORSO42G5

Figure 22 describes the clocking scheme for twin alignment. In twin alignment, the valid channel pairs are AC,AD in block A and BC,BD in block B. The figure provides the clocking scheme for block A as an example. RSYSCLKA2 should be sourced from RCK78A, RWCKAC or RWCKAD. For the ORSO42G5, the use of RCK78A is recommended since it uses primary clock routing resources. This clocking approach provides the required 0 ppm clock frequency matching for each pair and provides flexibility in applications where the two pairs are received from asynchronous sources.

Figure 22. Receive Clocking Diagram for Twin Alignment in Block A – ORSO42G5

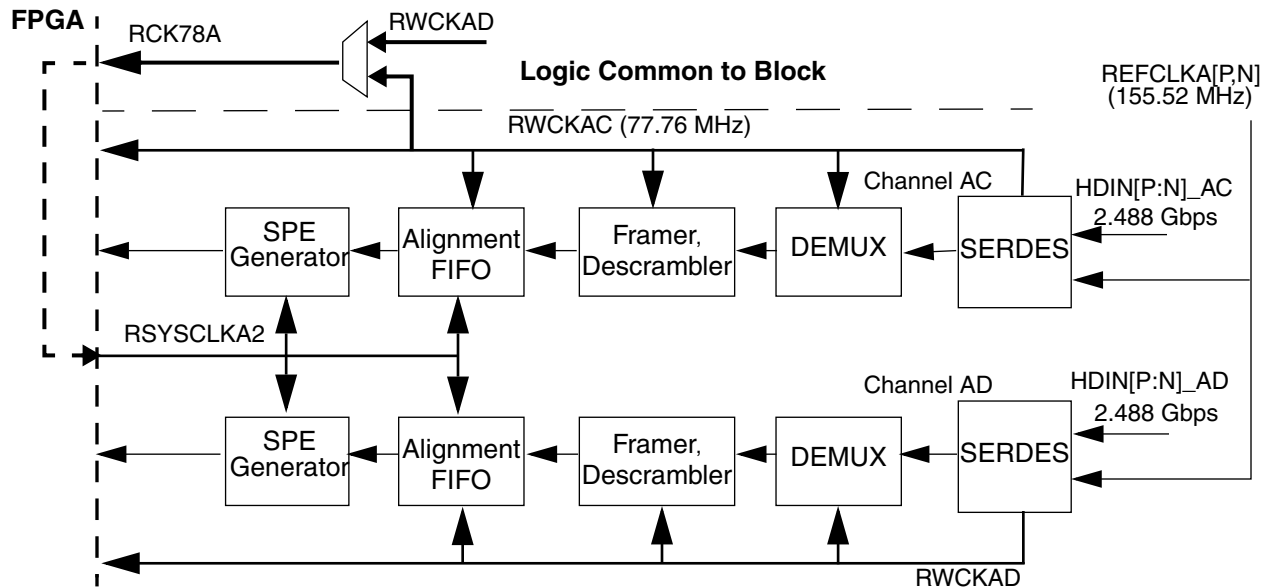

SONET Mode Quad Alignment – ORSO42G5

Figure 23 shows the clocking scheme for four-channel alignment. In this application, both clocks RSYSCLKA2 and RSYSCLKB2 should be sourced from a common clock. Either RCK78A or RCK78B can be used as a common clock source. The figure shows RCK78A being used as the clock source.

Figure 23. Receive Clocking Diagram for SONET Mode Quad-Channel Alignment in Block A – ORSO42G5

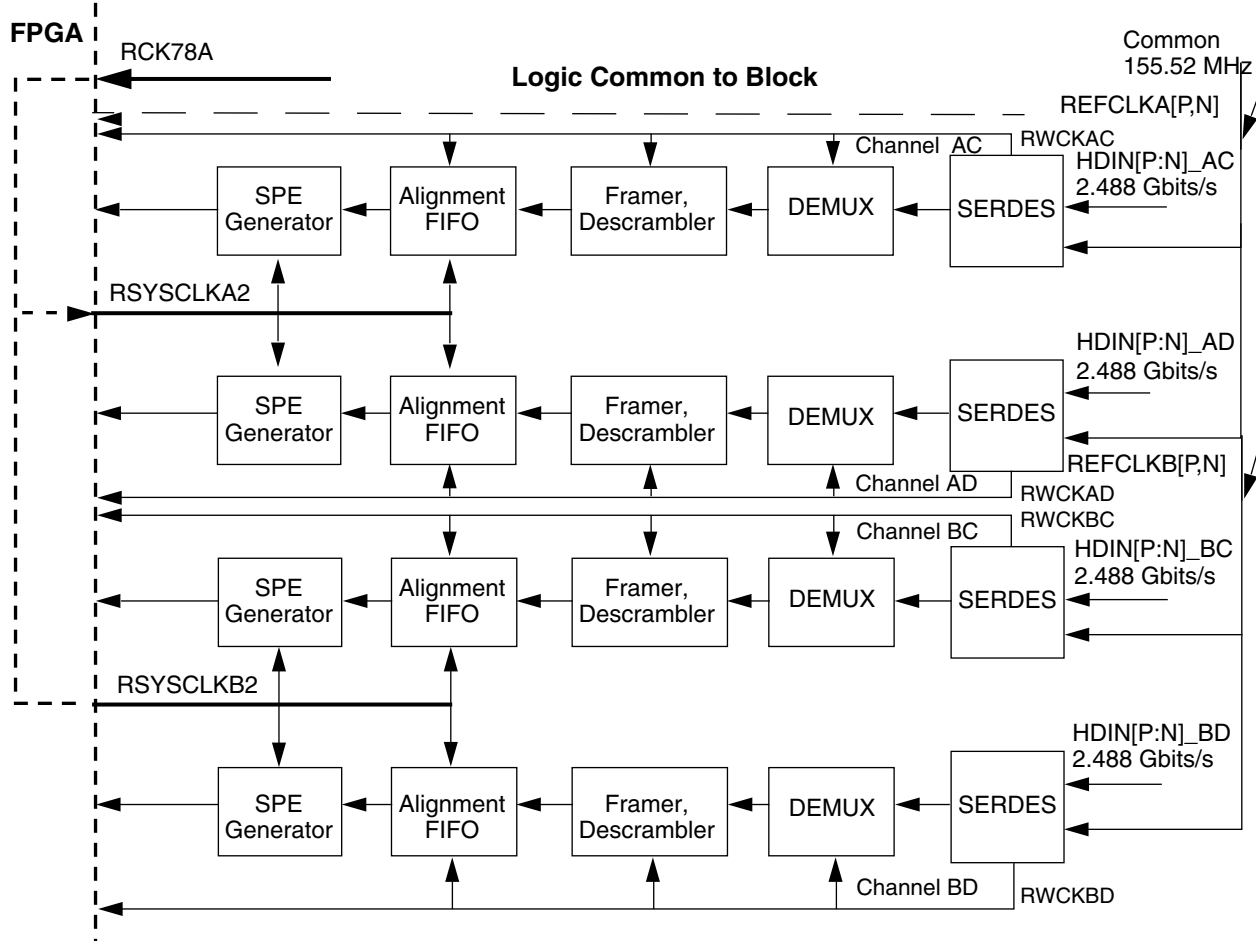

Multi-channel Alignment in SONET Mode (ORSO82G5)

The alignment FIFO allows the transfer of all data to a common clock. The FIFO sync block allows the system to be configured to allow the frame alignment of multiple slightly varying data streams. This optional alignment ensures that matching SERDES streams will arrive at the FPGA end in perfect data sync. It is important to note that for all aligned channels in a group, the SERDES transmitters on the other side of the high-speed link must all be transmitting data at exactly the same frequency (0 ppm difference), i.e., using a common clock source.

The ORSO82G5 has a total of eight channels (four per SERDES block). The incoming data of these channels can be synchronized in several ways, or they can be independent of one other. Two channels within a SERDES can be aligned together; channel A and B and/or channel C and D can form a pair as shown in Figure 24. Alternately, all four channels in a SERDES block can be aligned together to form a communication channel with a bandwidth of 10 Gbps as shown in Figure 25.

Finally, the alignment can be extended across the SERDES blocks to align all eight channels in the ORSO82G5 as shown in Figure 26. Individual channels within an alignment group can be disabled (i.e., powered-down) without disrupting other channels. Note that the SERDES channel that is powered down can not be the source of the RSY-SCLKxx that is clocking the read side of the alignment FIFO. When a disabled channel becomes active as part of an alignment group, the group may need to be re-aligned. Then the whole group needs to be resynched. This would only need to occur if the transmitting frame pulse for the new link is different from the rest of the group.

Figure 24. Twin Channel Alignment – ORSO82G5

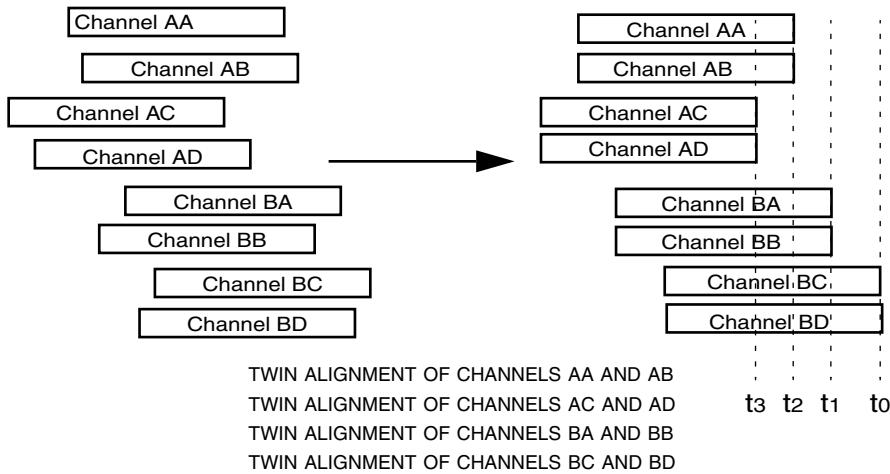

Figure 25. Alignment of SERDES Blocks A and B – ORSO82G5

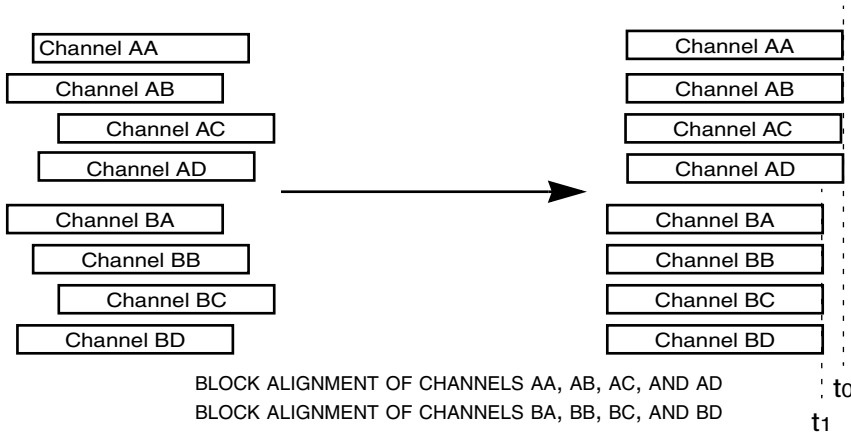
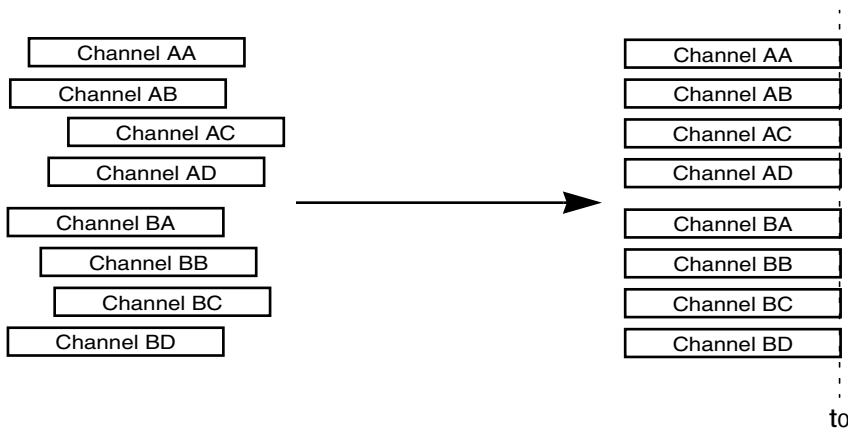

Figure 26. Alignment of all Eight SERDES Channels – ORSO82G5



Each channel is provided with a 24 word x 33-bit FIFO. The FIFO can perform two tasks: (1) to change the clock domain from receive clock to a clock from the FPGA side, and (2) to align the receive data over 2, 4, or 8 channels. This FIFO allows a timing budget of 307 ns that can be allocated to skew between the data lanes and for transfer to the common clock. The input to the FIFO consists of 32-bit data and a frame pulse that indicates the start of a

frame (or A1A2 framing bytes). This frame pulse is used to synchronize multiple channels within an alignment group.

If a channel is not in any alignment group, the FIFO control logic will set the FIFO-write-address to the beginning of the FIFO, and will set the FIFO-read-address to the middle of the FIFO at the first assertion of frame pulse after reset or after the resync command.

The RX_FIFO_MIN register bits can be used to control the threshold for minimum unused buffer space in the alignment FIFOs between read and write pointers before OVFL status is flagged. The synchronization algorithm consists of a down counter which starts to count down by 1 from its initial value of 18 (decimal) when a frame pulse from any channel within an alignment group has been received. The OOS alarm indicates the FIFO is out-of sync and the channel skew exceeds that which can be handled by the FIFO. Once the frame pulse for all channels within the alignment group have been received, the count is decremented by 2 until 0 is reached. Data are then read from the FIFOs and output to the SPE generator before being sent to the FPGA.

For every alignment group, there is an OVFL and OOS status register bit. The OOS bit is flagged when the down counter in the synchronization algorithm has reached a value of 0 and frame pulse from all channels within an alignment group have not been received. The OVFL bit is flagged when the read address at the time of receiving a frame pulse, is less than the minimum threshold set by RX_FIFO_MIN. In the memory map section OOS is referred to as SYNC[2,4]_[A1,A2,B1,B2]_OOS, SYNC8_OOS. OVFL is referred to as SYNC[2,4]_[A1,A2,B1,B2]_OVFL, SYNC8_OVFL.

Receive Clocking for Multi-channel Alignment – ORSO82G5

There are a total of nine clocks for the receive path, from FPGA to the core. The four used in SONET mode are RSYSCCLKA1 and RSYSCCLKA2 (both for block A), and RSYSCCLKB1 and RSYSCCLKB2 (both for block B). The following diagrams show the recommended clock distribution approaches for SONET mode multi-channel alignment modes. Cell mode alignment is discussed in the section describing the Input Port Controller (IPC.)

SONET Mode Twin Alignment

Figure 27 describes the clocking scheme for twin alignment in the ORSO82G5. In twin alignment, the valid channel pairs are AA,AB and AC,AD in block A and BA,BB and BC,BD in block B. The figure provides the clocking scheme for block A as an example. RSYSCCLKA1 should be sourced from RWCKAA or RWCKAB. RSYSCCLKA2 should be sourced from RWCKAC or RWCKAD. This clocking approach provides the required 0 ppm clock frequency matching for each pair and provides flexibility in applications where the two pairs in the block are received from asynchronous sources or operate at different rates.

Figure 27. Receive Clocking Diagram for Twin Alignment in Block A – ORSO82G5

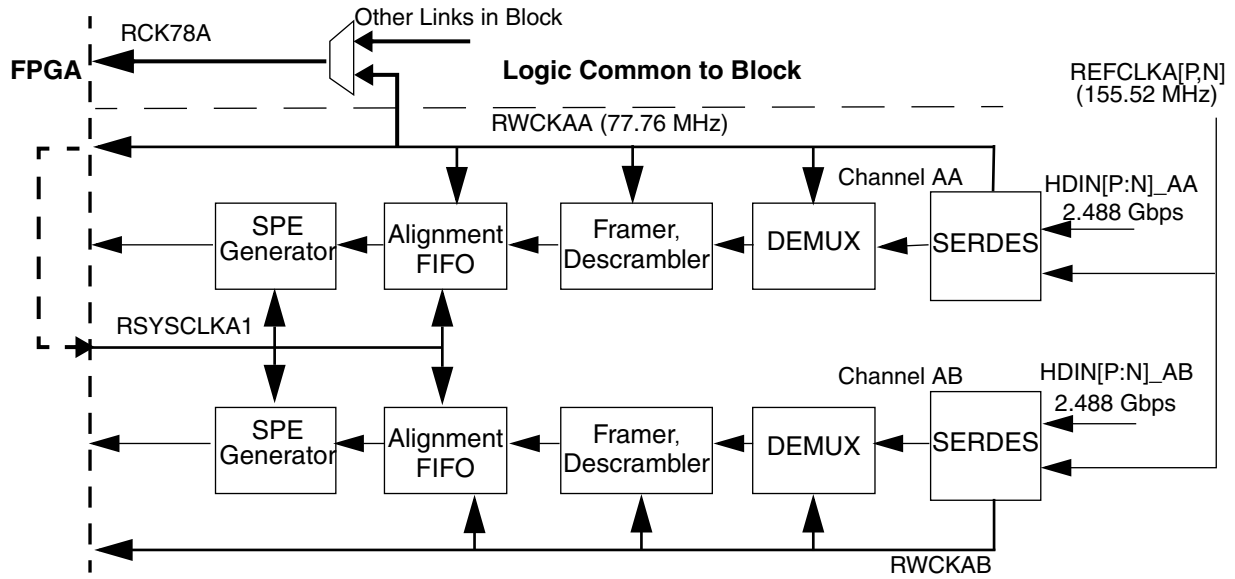

SONET Mode Block Alignment – ORSO82G5

Figure 28 describes the clocks and recommended clocking for block alignment in the SONET mode. For block alignment, the low speed portion for each block should be sourced by a single clock. As the figure shows, for block A, RSYCLKA1 and RSYCLKA2 should be sourced by RCK78A. For block B, RSYCLKB1 and RSYCLKB2 should be sourced by RCLK78B. RCLK78A can be sourced by any channel in block A and RCLK78B can be sourced by any channel in block B.

Figure 28. Receive Clocking Diagram for Four-Channel Alignment in Block A – ORSO82G5

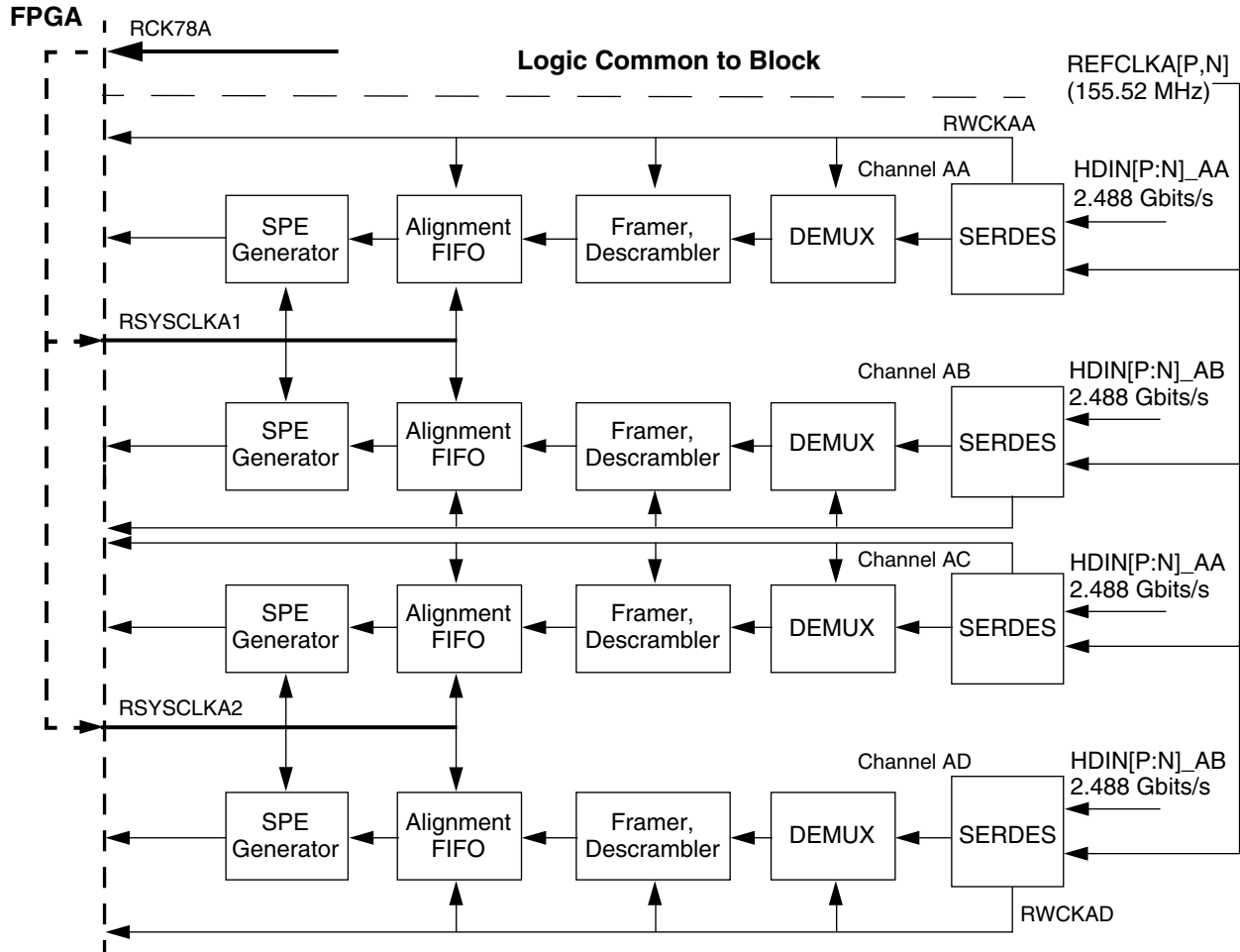

SONET Mode Octal Alignment – ORSO82G5

Figure 29 shows the clocking scheme for eight-channel alignment. In this application, all four clocks RSYCLKA1, RSYCLKA2, RSYCLKB1 and RSYCLKB2 should be sourced from a common clock. Either RCK78A or RCK78B can be used as a common clock source. The figure shows RCK78A being used as the clock source.

Figure 29. Receive Clocking Diagram for SONET Mode Eight-Channel Alignment – ORSO82G5

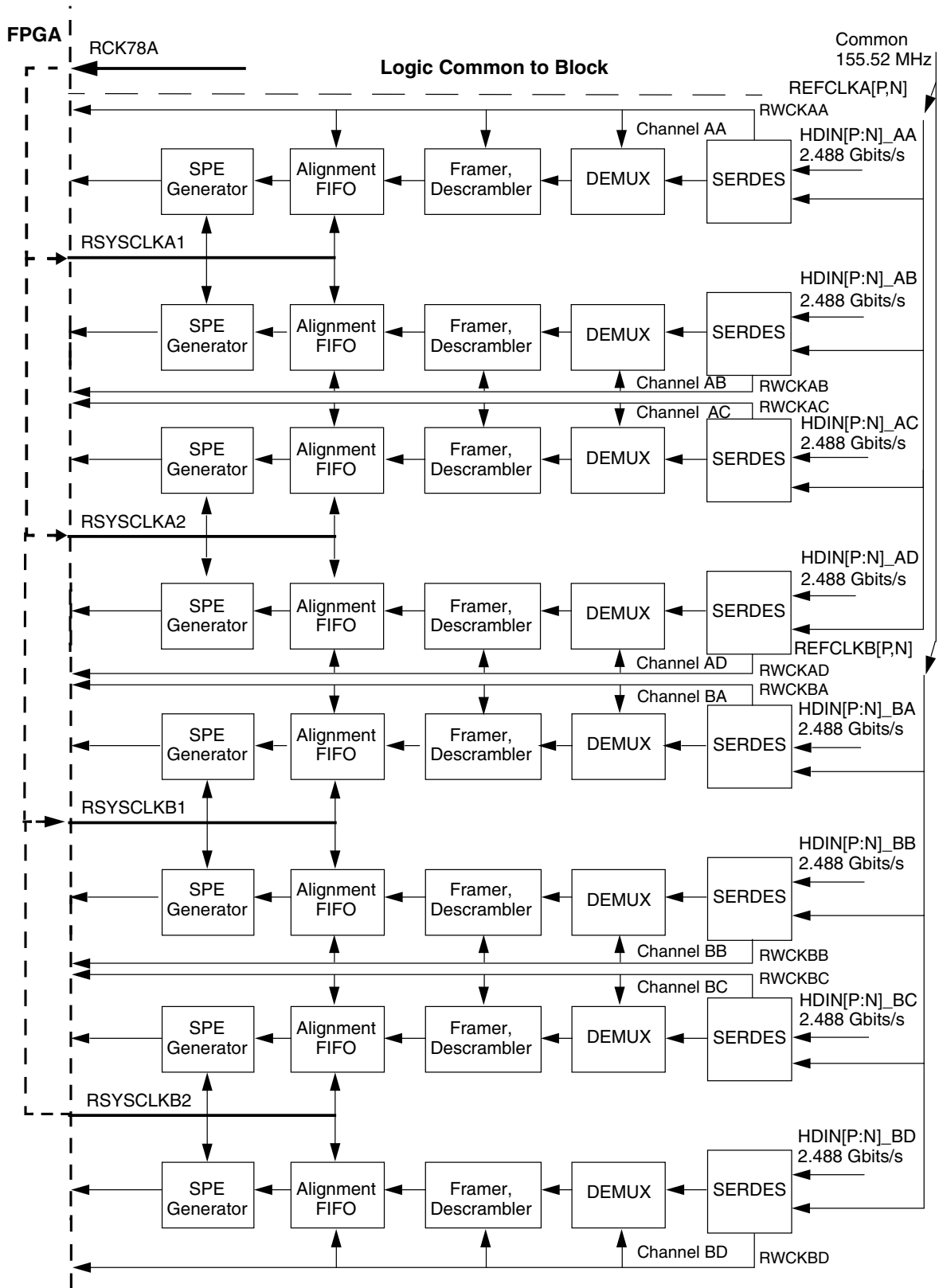

SPE Generator

The SPE generator in the ORSO42G5 and ORSO82G5 is used to indicate the payload and overhead portions of a SONET frame. It is present in the SONET data path only. The SPE generator generates row, column and STS counters based on the frame pulse received from the (24 x 33) alignment FIFO or from the descrambler if alignment FIFOs are bypassed. It also retimes the 32-bit data in order to align it with the SPE indicator. The SPE generator will also detect negative or positive pointer justification (if justification is enabled) by looking at the ID bits in the H1 and H2 bytes and adjust the SPE indicator for the STS-1 frame being justified as follows:

- During positive pointer justification, the SPE will be low during H3 byte and the SPE byte following it.
- During negative pointer justification, the SPE will be high during H3 byte.
- During no justification, the SPE will be low during H3 byte.

This block only detects the incoming pointer bytes for SPE generation. This capability can be enabled by software control. By default, the SPE generator will ignore any pointer justification. This block has no capability of any pointer processing, pointer checking or pointer mover operation and ignores “new data” indications from the SONET specification.

SONET Mode Receive Timing – ORSO42G5

This section contains timing diagrams for major interfaces of this block to the FPGA logic when SONET frames are to be transferred.

- When operating in SONET mode, the entire SONET frame is sent to the FPGA. In multi-channel alignment mode(s), data from all channels within an alignment group are aligned to the A1A2 framing bytes.
- Each SONET frame is 125µs. The frame starts with 36 clock cycles (77.76 MHz) of TOH followed by 1044 clock cycles of SPE, followed by 36 clock cycles of TOH, 1044 cycles of SPE.
- The DOUTxx_SPE signal indicates TOH or SPE in the data (low for TOH, high for SPE)
- Twin pairs are AC, AD (group A2) and BC, BD (group B2)

Figure 32 shows the SONET twin alignment mode timing for the ORSO42G5. The frame pulse and SPE indicators are show for each of the two channels (AC, AD) in twin alignment.

Figure 30. Receive Clocking Diagram for SONET Mode Twin Alignment in Block A – ORSO42G5

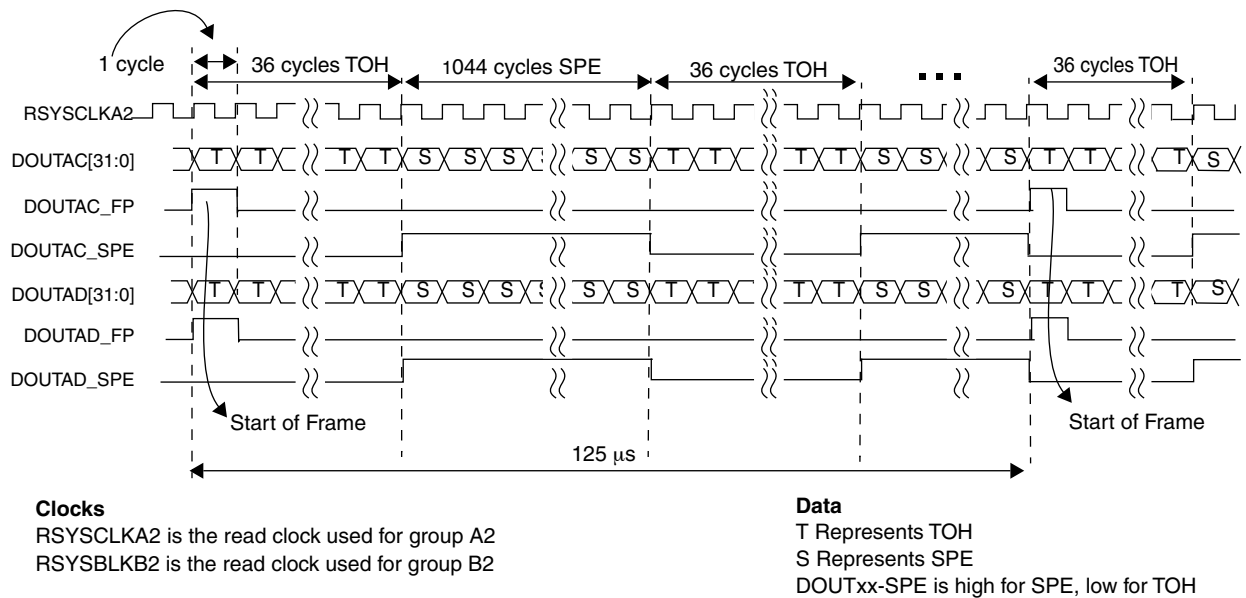
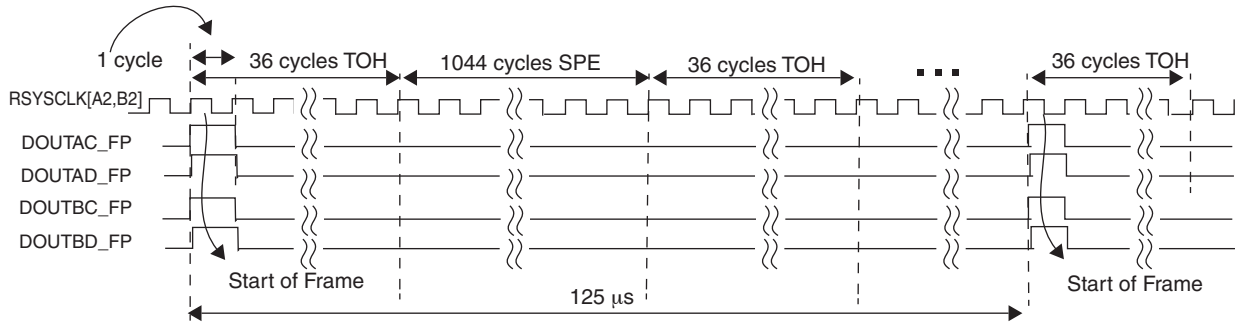

Figure 31 shows the quad alignment mode in the ORSO42G5.

Figure 31. Receive SONET Mode, Quad Alignment Mode – ORSO42G5



Clocks

RSYSCLKA2 and RSYCLKB2 are sourced by RCK78A

SONET Mode Receive Timing – ORSO82G5

This section contains timing diagrams for major interfaces of this block to the FPGA logic when SONET frames are to be transferred.

- When operating in SONET mode, the entire SONET frame is sent to the FPGA. In multi-channel alignment mode(s), data from all channels within an alignment group are aligned to the A1A2 framing bytes.
- Each SONET frame is 125μs. The frame starts with 36 clock cycles (77.76 MHz) of TOH followed by 1044 clock cycles of SPE, followed by 36 clock cycles of TOH, 1044 cycles of SPE.
- The DOUTxx_SPE signal indicates TOH or SPE in the data (low for TOH, high for SPE)
- Twin pairs are AA, AB (group A1), AC, AD (group A2), BA, BB (group B1) and BC, BD (group B2)

Figure 32 shows the SONET twin alignment mode timing for the ORSO82G5. The frame pulse and SPE indicators are shown for each of the two channels (AA, AB) in twin alignment.

Figure 32. Receive Clocking Diagram for SONET Mode Twin Alignment in Block A – ORSO82G5

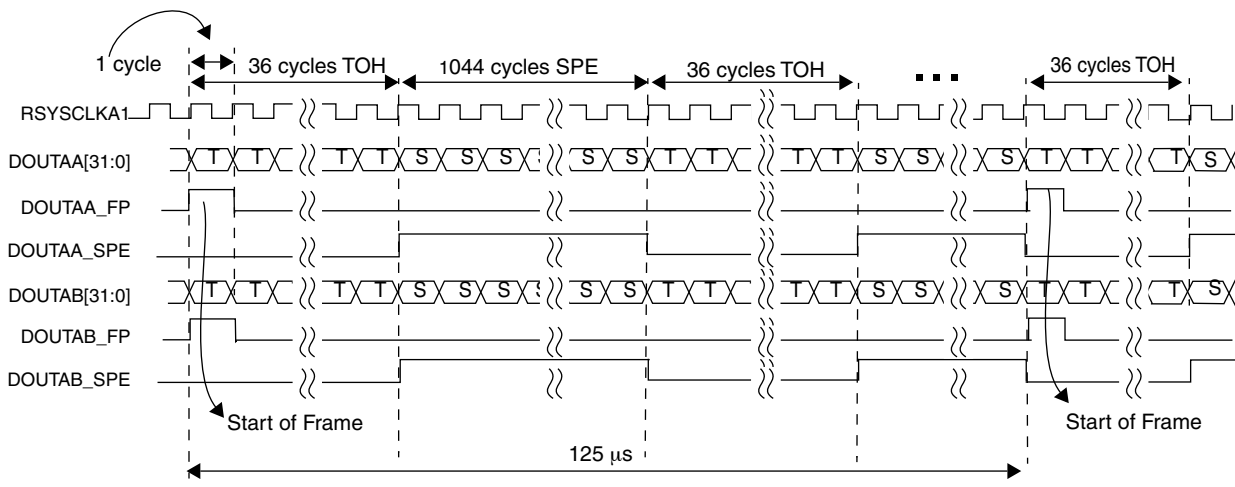

Clocks

RSYSCLKA1 is the read clock used for group A1
 RSYCLKA2 is the read clock used for group A2
 RSYCLKB1 is the read clock used for group B1
 RSYCLKB2 is the read clock used for group B2

Data

T Represents TOH
 S Represents SPE
 DOUTxx-SPE is high for SPE, low for TOH

Figure 33 shows the SONET quad alignment mode in the ORSO82G5.

Figure 33. Receive Clocking Diagram for SONET Mode Quad Alignment – ORSO82G5

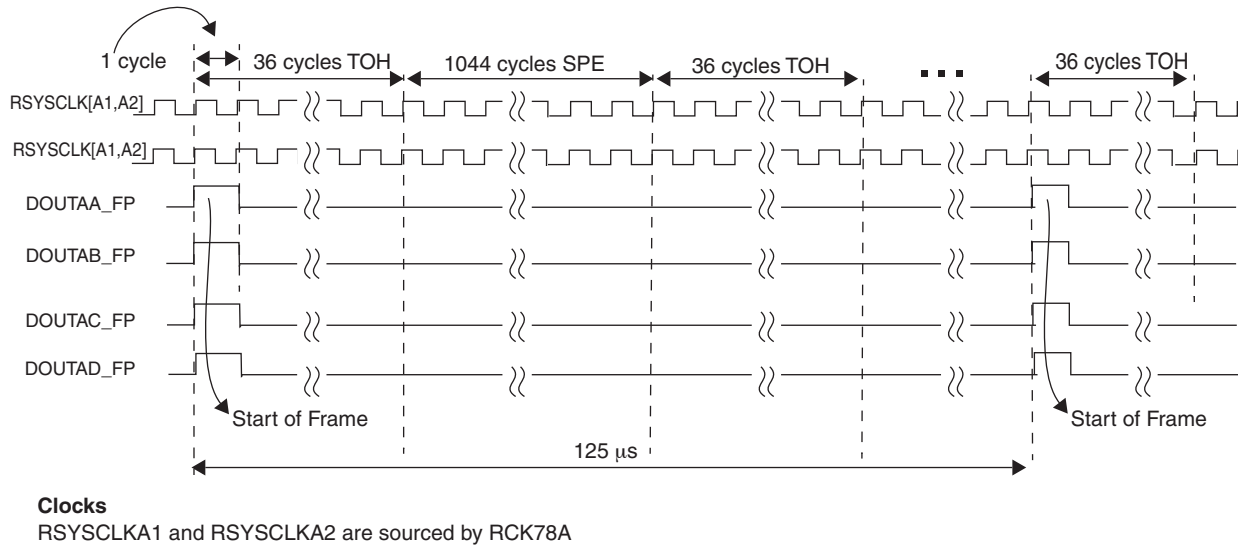

- Only frame pulse (DOUTxx_FP) and clocks are shown for understanding of block alignment.
- Timing of data and SPE indicators are the same as shown for twin alignment.
- Block groups are Group A - AA,AB,AC,AD and Group B - BA,BB,BC,BD

Figure 34 shows the octal alignment mode in the ORSO82G5.

Figure 34. Receive SONET Mode—Octal Alignment Mode – ORSO82G5

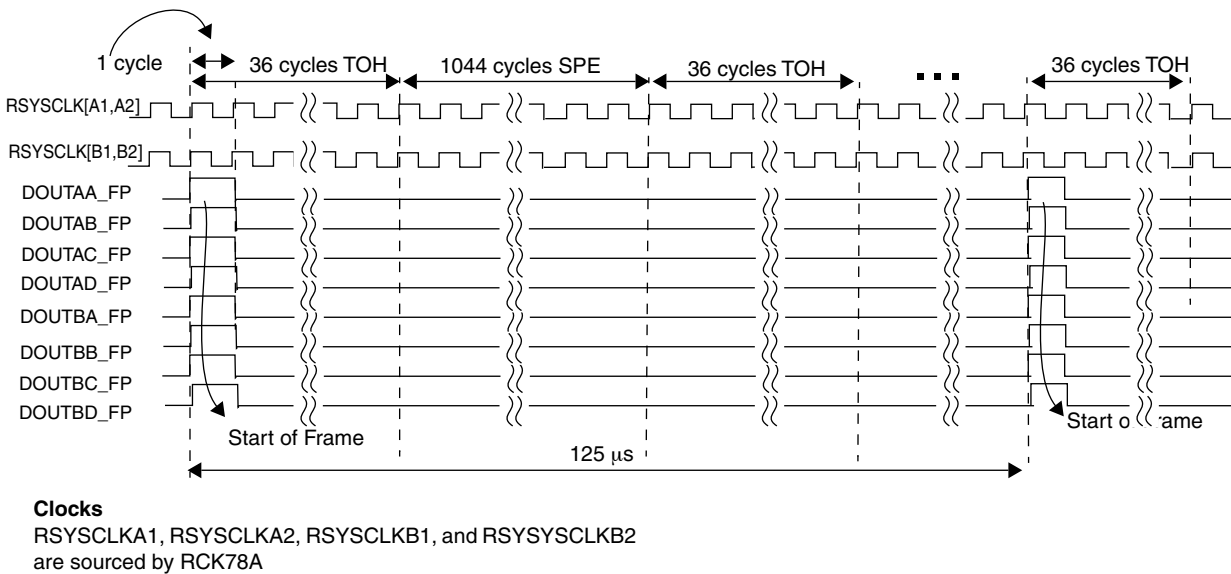

ORSO42G5 Configuration

At startup, the legacy SERDES channel logic must be powered down and removed from any multi-channel alignment groups:

- Setting bit 1 to one in registers at locations 30002, 30012, 30102 and 30112 powers down the legacy logic. (Note that the reset value for these bits is 0.)
- Setting bit 1 to zero (reset condition) in the register at locations 30802, 30812, 30902 and 30912 removes the legacy logic from any alignment group.

Register settings for SONET multi-channel alignment are shown in Table 7.

Table 7. Multichannel Alignment Modes – ORSO42G5

| Register Bits FMPU_SYNMODE_xx[2:3] | Mode |
|---------------------------------------|---------------------------|
| 00 | No multichannel alignment |
| 01 | Twin channel alignment |
| 11 | Four channel alignment |

Note: xx = [AC,AD,BC,BD]

To align two channels in SERDES A:

- FMPU_SYNMODE_AC = 01 (Register Location 30822)
- FMPU_SYNMODE_AD = 01 (Register Location 30832)

To align two channels in SERDES B:

- FMPU_SYNMODE_BC = 01 (Register Location 30922)
- FMPU_SYNMODE_BD = 01 (Register Location 30932)

To align all four channels:

- FMPU_SYNMODE_AC = 11 (Register Location 30822)
- FMPU_SYNMODE_AD = 11 (Register Location 30832)
- FMPU_SYNMODE_BC = 11 (Register Location 30922)
- FMPU_SYNMODE_BD = 11 (Register Location 30932)

To enable/disable multi-channel alignment of individual channels within a multi-channel alignment group:

- FMPU_STR_EN_xx = 1 enabled
- FMPU_STR_EN_xx = 0 disabled

where xx = [AC,AD,BC,BD]

To resynchronize a multichannel alignment group set the following bits to one, and then set to zero:

- FMPU_RESYNC4 for four channels, AC, AD, BC and BD. (Register Location 30A04, bit 7)
- FMPU_RESYNCA2 for dual channels, AC and AD. (Register Location 30A04, bit 2)
- FMPU_RESYNCB2 for dual channels, BC and BD. (Register Location 30A04, bit 5)

To resynchronize an independent channel (resetting the write and the read pointer of the FIFO) set the following bits to one, and then set to zero.

- FMPU_RESYNC1_xx (Register Locations 30824, 20834, 30924 and 30934, bit 7) where xx is one of AC, AD, BC or BD.

Alignment Mode Setup Procedures – ORSO82G5

The control register bits for alignment FIFO in the ORSO42G5 and ORSO82G5 are described below.

Table 8. Multichannel Alignment Modes – ORSO82G5

| Register Bits FMPU_SYNMODE_xx | Mode |
|----------------------------------|--------------------------------------|
| 00 | No multichannel alignment. (default) |
| 01 | Twin channel alignment |
| 10 | Block channel alignment |
| 11 | Eight channel alignment |

Note: Where xx is one of A[A:D] and B[A:D].

To align all eight channels:

- FMPU_SYNMODE_A[A:D] = 11
- FMPU_SYNMODE_B[A:D] = 11

To align twin channels in SERDES A:

- FMPU_SYNMODE_A[A:D] = 01

To align four channels in SERDES A:

- FMPU_SYNMODE_AB = 10
- FMPU_SYNMODE_AD = 10

Similar alignment can be defined for SERDES B. To enable/disable synchronization signal of individual channel within a multi-channel alignment group:

- FMPU_STR_EN_xx = 1 enabled
- FMPU_STR_EN_xx = 0 disabled
where xx is one of A[A:D] and B[A:D].

To re-synchronize a multi-channel alignment group

Set the following bit to zero, and then set it to 1 since it is a rising edge sensitive bit.

- FMPU_RESYNC8 for eight channel A[A:D] and B[A:D]
- FMPU_RESYNC4A for block channel A[A:D]
- FMPU_RESYNC2A1 for twin channel A[A:B]
- FMPU_RESYNC2A2 for twin channel A[C:D]
- FMPU_RESYNC4B for block channel B[A:D]

Re-synchronization will cause the multi-channel alignment group to perform a new synchronization procedure. This would need to occur if a link is removed from an alignment group and then paced back into service as part of the alignment group. This is not required at power up if the alignment mode is set before the channels receive the first frame pulse.

Cell Mode Detailed Description

A common application for the ORSO42G5 and ORSO82G5 is to provide a bridge between a port card and a cell-based switch fabric. In cell mode, the data in the Synchronous Payload Envelope (SPE) of the SONET frames is further formatted into fixed-length cells by the ORSO42G5 and ORSO82G5. The cell contents will typically be unique to specific port card and switch devices. The ORSO42G5 and ORSO82G5 supports this application with a “cell mode” of operation

The basic data flows in cell mode are shown in Figure 35. Data to be transmitted is received from the FPGA logic (see Table 11 and Table 12 for details of the core/FPGA signal assignments in the transmit direction which differ significantly from the SERDES only and SONET modes), inserted into the SPE of the SONET frame, scrambled and transmitted from the SERDES block. In cell mode, multiple SERDES links are used to achieve desired bandwidth. A two-link mode is supported in the ORSO42G5 and both two-link and eight-link cell modes are supported. For such interfaces, data are cell-stripped in a round-robin fashion across multiple links by the transmitter.

Figure 35. Basic Data Flows - Cell Mode

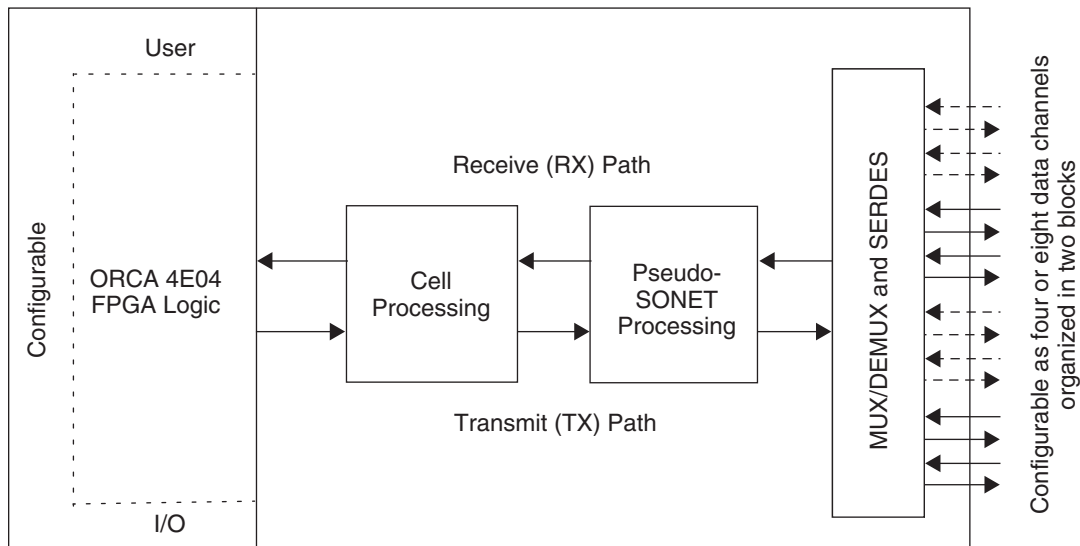

In the receive direction, the framed data are received from the SERDES block, descrambled and are passed into a cell extractor which extracts individual cells from the payload portion of the SONET frame. The cells are then passed through a FIFO that performs lane-to-lane deskew and a clock domain transfer. The clock domain transfer is handled automatically using idle cell insertion and deletion.

The cells are passed into either the eight-link Input Port Controller IPC8 block (ORSO82G5 only) or to one of the two-link IPC2 block(s), which reassemble the cells back into a single cell stream (destriping) which is sent to the FPGA logic. (See Table 13 and Table 14 for details of the core/FPGA signal assignments in the receive direction. As with the transmit path, the cell mode assignments differ significantly from those for the SERDES only and SONET modes).

SERDES and SONET processing has been described in previous sections and only features unique to the cell mode will be discussed in the following sections. The cell format will be discussed first, followed by a description of the transmit path, which will include either a two-link or an eight-link Output Port Controller (OPC) block, and a description of the receive path, including the two-link or eight-link Input Port Controller (IPC) blocks.

Cell Formats

Cells are arranged within a SONET (STS-48c) frame as shown in Figure 36. A SONET STS-48c frame has 4176 (87 x 48) columns of SPE and 9 rows that gives a total of 37,584 bytes. In this implementation, data in a SPE is limited to fixed size cells. Though four cell sizes are supported, only one cell size can be used at a time.

Figure 36. Cell Mapping in SONET Frame

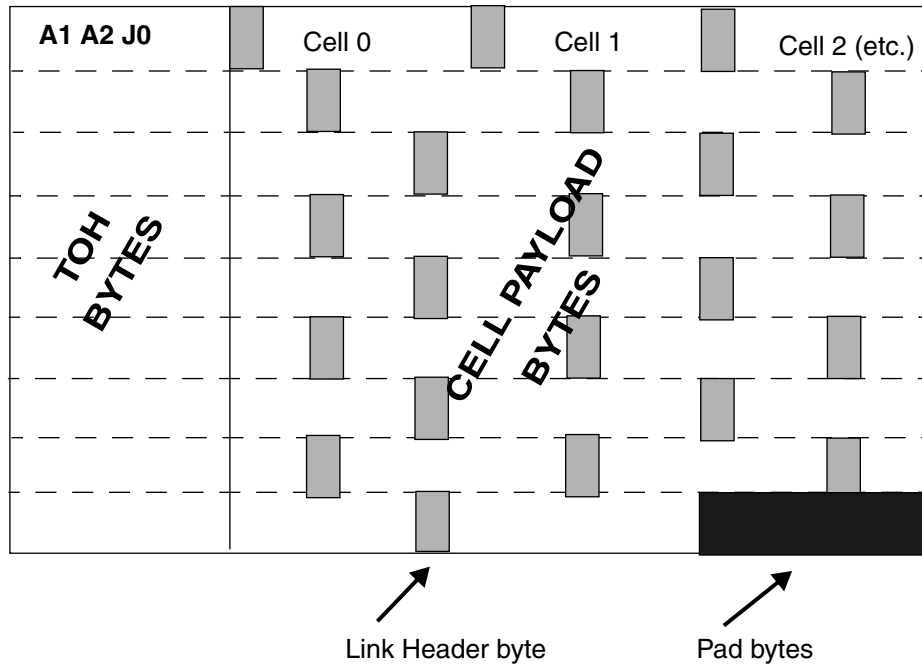

The cells are placed in a SONET frame such that the first cell starts at the first SPE column of the first row (145th column. 144 columns are taken up by TOH). Subsequent cells are placed contiguously, skipping the Transport OverHead (TOH) columns when appropriate.

The ORSO42G5 and ORSO82G5 supports four cell sizes with varying payloads. The total cell size sent across the backplane is the combined size of the user cell payload (cell header and data), user BIP and the Link Header byte. Table 9 indicates the cell sizes supported by the ORSO42G5 and ORSO82G5 within a STS-48c frame. Only one cell size can be used at a time.

Table 9. ORSO42G5 and ORSO82G5 Supported Cell Sizes

| Total Cell Size (Across B/P) | User Cell Payload Size (Header/Data) | Link Header Byte | User BIP Field | Cells/Frame | Number of Pad Bytes Per SPE |
|------------------------------|--------------------------------------|------------------|----------------|-------------|-----------------------------|
| 77 | 75 | 1 | 1 | 488 | 8 |
| 81 | 79 | 1 | 1 | 464 | 0 |
| 85 | 83 | 1 | 1 | 442 | 14 |
| 93 | 91 | 1 | 1 | 404 | 12 |

Note:

To calculate the number of cells per SPE:

$$[(87\text{Rows}/\text{STS}-1 * 9\text{Columns}/\text{STS}-1)\text{octets}/(\text{STS}-1 \text{SPE})] * 48 \text{STS}-1 = 37584 \text{octets}$$

$$337584 / \text{TOTAL CELL SIZE} = \# \text{ of cells per SPE.}$$

A cell cannot span multiple SONET frames. This implies that there may be some cell sizes for which some bytes will be unused at the end of a SPE. These are called pad bytes.

Each cell is preceded by a Link Header byte as shown in Figure 37. Table 10 defines the format of the Link Header. The Link Header byte is useful for cell delineation when cell data are striped across multiple links. The Link Header is inserted automatically in the transmit direction by the IPC block. The Link Header is checked in the receive direction and removed by the OPC before the cell is sent across the core/FPGA interface.

Figure 37. Link Header Byte

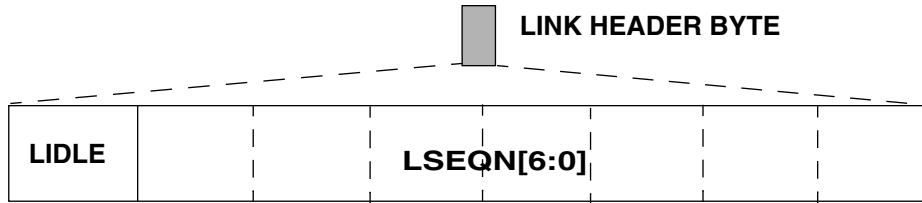
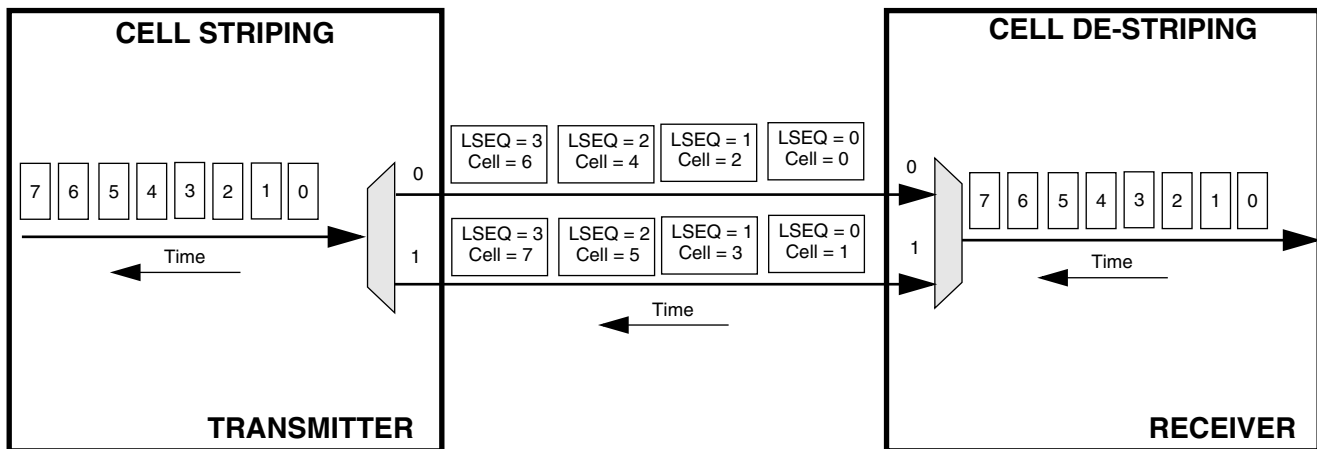

Table 10. Link Header Format

| Location | Field/Description |
|----------|--|
| 7 | Idle: Idle Cell Indicator 0: User Cell (contains valid data) 1: Idle Cell (no data in the cell payload) |
| 6:0 | LSEQ: Link Sequence Number. This value is used when aligning cells from multiple links when doing link group multiplexing. |

In cell mode, multiple SERDES links are used to achieve desired bandwidth. Data are cell-stripped in a round-robin fashion across two or eight links by the transmitter and then re-assembled back into a single cell stream (destriping) by the receiver. This is shown in Figure 38.

Figure 38. Multi-Link Interface - Two-Link Example



To assist with cell delineation, each link transmitter assigns sequence numbers to cells (LSEQN[6:0] bits in the Link Header byte) before sending them out on the link. Each link increments its sequence numbers independently as shown in Figure 38. All links reset their sequence number generator at the beginning of a SONET frame (All links are synchronized to the start of a frame).

On the receiving side, each receiver uses the sequence numbers to verify the correct cell delineation. Since the links were synchronized to the start of the SONET frame, all links will have cells with the same sequence number available at the same time (although deskew needs to happen to properly align the cells). This allows the receiver to correctly reconstruct the original cell stream.

If an unexpected sequence number is received, the receiver does not use the received value as the basis for the next expected sequence number. Rather the old expected value is incremented by one, forming the new expected value. An error flag is sent to the software register interface and the cell will be marked with an error. For example, assume that the receiver expected to receive a cell with sequence number 27, but received one with sequence number 37. The cell will be marked with an error. The receiver then expects to receive a cell with sequence number 28.

There is no way to tell where a cell starts unless one counts the cells from the beginning of the SPE. That means, there is no way to regain lost cell delineation other than wait for the next SONET frame.

Cell Mode Transmit Path

In the transmit path in cell mode, the transmit logic creates a SONET-like transport frame for the data, adds the required Transport OverHead bytes (cell mode automatically uses AUTO_TOH mode) and retimes the cell data from the FPGA interface rate of 156 MHz to the framer rate of 77.76 MHz. The data are then sent to the SONET logic blocks and SERDES. The Payload sub-block of the SONET logic operates somewhat differently than in SONET mode, however.

Output Port Controller

The ORSO42G5 has two link controllers (OPC2s). In cell mode the Output Port Controller (OPC) is the block responsible for directing traffic for the transmit traffic flow. There are four two-link controllers and one eight-link controller (OPC8) in the ORSO82G5. The user provides 160-bit data (OPC8) or 40-bit data (OPC2s) at 156 MHz, along with a cell valid strobe from the FPGA logic. No Link Header byte is sent with the cell data. The OPC provides the following functions:

- Accepts cell payload from the FPGA logic and assembles legal output cells from these.
- Inserts Bit Interleaved Parity (BIP)
- Schedules, manages and performs writes of cell data into TX FIFOs in the transmit framer blocks of all the eight-links or up to 4 pairs of two-links.
- Provides backpressure information to the FPGA to stop writes to the TXFIFO if the FIFO is not ready to accept data.

The OPC blocks, shown in Figure 39, operate as follows:

- OPC8 to stripe cells across eight links (ORSO82G5 only)
- OPC2_A1 to service links AA,AB (ORSO82G5 only)
- OPC2_A2 to service links AC,AD
- OPC2_B1 to service links BA,BB (ORSO82G5 only)
- OPC2_B2 to service links BC,BD

When operating with some links in the two-link cell mode, links not in an alignment group can optionally be operated in SONET and/or SERDES-only modes.

Figure 39. OPC2 and OPC8 Block Diagrams

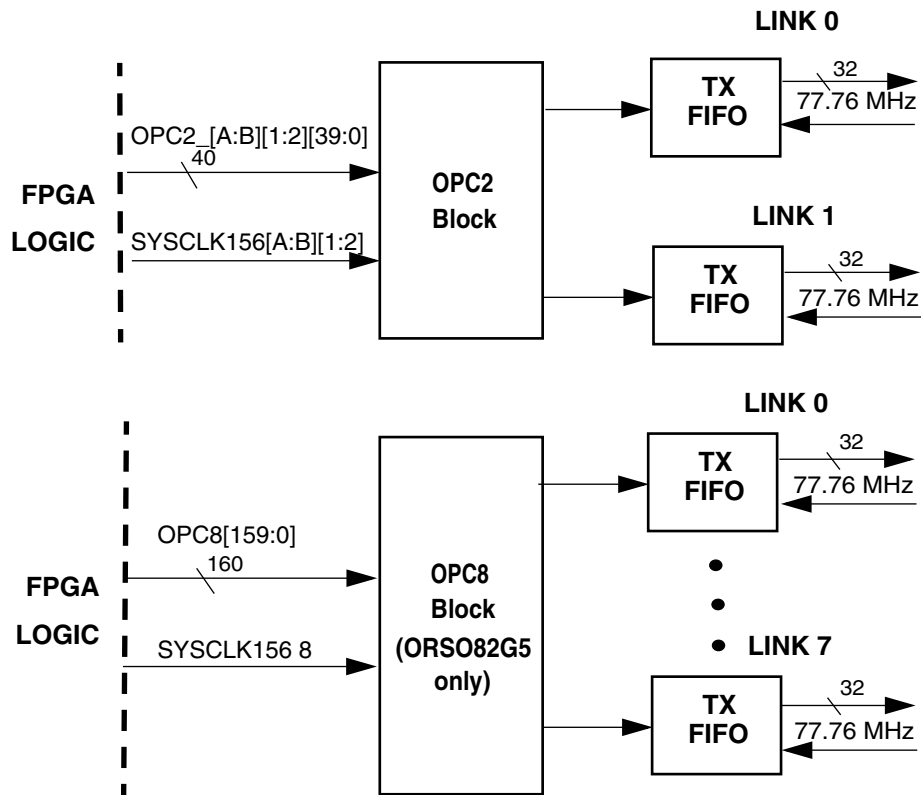

TX FIFO Block

In cell mode, the TXFIFO block contains the write state machine and FIFO memory. The FIFO is used to retime the cell data from the FPGA interface at a rate of 156 MHz to the framer rate of 77.76 MHz.

The FIFO memory is implemented as a 64 x 34 FIFO. The FIFO receives data as 33-bit words with the start-of-cell as the MSB of each word. Thus each cell occupies a maximum size of 23 words. For each link, the memory must be capable of holding at least 2 cells or 46 words (one for write and one for read). To ensure extra space, this capacity has been increased to 64 words. In addition, an extra bit has been reserved to store the link idle cell indicator bit which is used for indicating the internally generated idle cells. Thus each word in a cell is 34 bits. Data are written to the memory on the 156 MHz clock domain and read on the 77.76 MHz clock domain by the Tx_Frame_Processor block. The OPC requires no response from the TXFIFO for writing data. The TXFIFO is guaranteed by design to not overflow or underrun with correct clocking.

TX Frame Processor

The Tx_Frame_Processor (TFP) block is the primary data processing block in the both SONET mode and cell mode. It organizes the cell data into a SONET frame before sending it to the SERDES. In cell mode, the 32-bit data comes from the TX FIFO block. The three major TFP sub-blocks were described in the SONET mode section.

In cell mode, the Payload sub block is activated by the link_frm_sync in cell mode. A pulse on this signal from the OPC indicates the start of a frame. Each frame contains 4 different types of bytes in cell mode:

- TOH bytes (Auto TOH mode only)
- Link Header (LH) bytes
- Cell payload bytes
- Pad bytes

There are $N \times 3$ ($N = 48$) bytes of TOH per row and there are a total of 9 rows in a SONET frame. In cell mode, the rest of the bytes in each row after the TOH bytes are filled by cells. The first byte in a cell is a Link Header (LH) byte. At the end of each frame, there are pad bytes if required.

An important function of the payload block is the grouping of bytes together to be presented to the scramble logic. Due to the insertion of the LH byte in each cell, the total cell data are not divisible by 4 (4 bytes are sent per 77.76 MHz clock cycle). At the end of each row within a SONET frame, the payload block stops sending cell data and indicates to the TOH block to insert the next row's TOH bytes. At the end of the TOH byte transmission, the cell data transmission is resumed.

At the end of a cell, the cell's BIP-8 byte is inserted. The next cell's Link Header byte (LH) immediately follows the previous cell's BIP-8 byte. The MSB of the LH byte is the link idle cell indicator bit. The payload block gets this bit from the MSB of the first word of a cell in the memory and inserts it into the LH byte for the appropriate cell. The rest of the LH byte is the link sequence number. This number is incremented for each subsequent cell.

After all cells have been transmitted, the appropriate number of pad bytes are sent. At a link speed of 2.5 GHz, there are 38,880 bytes (SPE + TOH) per frame. There are 1296 bytes of TOH and 37,584 bytes of SPE. For cell data of 85 bytes this translates to 442 cells per frame and 14 pad bytes (# of cells per frame = # of bytes of SPE/# of bytes in a cell).

Cell Mode Transmit Timing

Figure 40 shows the transmit clocks and recommended clocking scheme in cell mode. TCK156A, TCK157B can be used as a 156 MHz clock source for SYSCLK156[A1, A2] and SYSCLK156[B1, B2] respectively. SYSCLK156[A1, A2] and SYSCLK[B1, B2] are shared with the receive logic in cell mode.

Figure 40. Cell Mode Transmit Timing

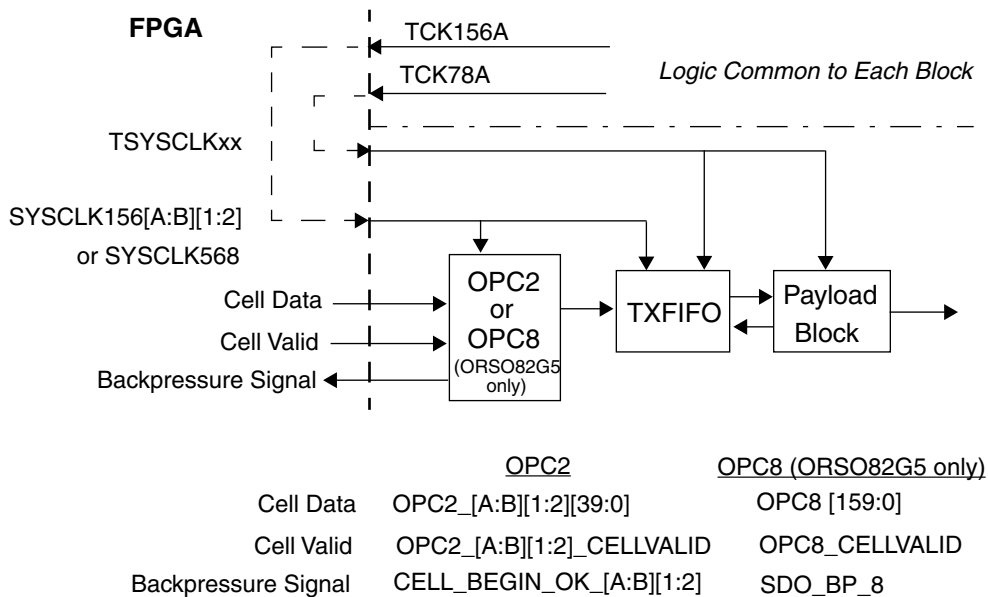

When operating in the two-link CELL MODE, each OPC2 Block passes cells from FPGA to embedded core. Depending upon the configured CELL SIZE, cell transfers will take a variable number of SYSCLK156 cycles to be transmitted across the interface. Data are always transferred across a 40-bit bus (5 octets per clock cycle). Figure 41 shows 16 clock cycles for a cell transfer this corresponds to a cell size of 79 octets. The two control signals in the figure are defined as:

cell_begin_ok: cell request signal from core to FPGA. It will be asserted every 20 or 16 clock cycles (depending on cell size) when the core is ready to accept cells from FPGA.

- If core FIFO cannot accept cells, cell_begin_ok will be low.
- If core FIFO is empty then cell_begin_ok will be asserted every 4 clock cycles until cellvalid is asserted by user to indicate valid cell data.

cellvalid: Clock-wide pulse asserted by user to indicate valid data. Asserted on the clock cycle following cell_begin_ok.

Figure 41. ORSO42G5 and ORSO82G5 Transmit FPGA Interface OPC2 Cell Mode

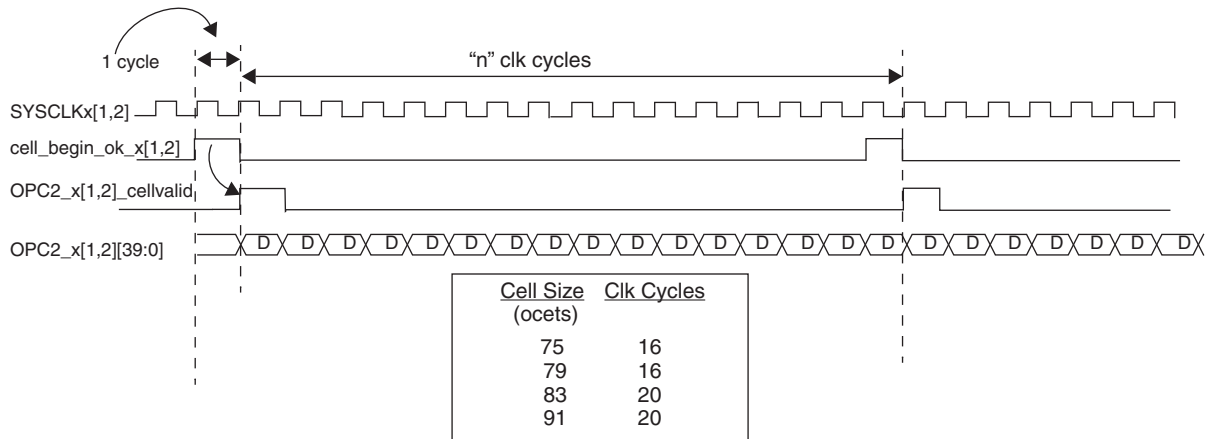

When operating in the eight-link cell mode, the OPC8 block passes user cells from FPGA to embedded core. Depending upon the configured CELL SIZE, cell transfers will take a variable number of SYSCLK156 cycles to be transmitted across the interface. Data are always transferred across a 160-bit bus (20 octets per clock cycle). Figure 42 shows five clock cycles for a cell transfer this corresponds to a user cell size of 91 octets. The two control signals in the figure are defined as:

sdo_bp_8: Backpressure signal from core instructing user to stop sending cell data. User should complete transmitting the current cell and can send one more cell before deasserting cellvalid.

cellvalid: Is high throughout a cell transfer to indicate valid cell data

Figure 42. ORSO82G5 Transmit FPGA Interface OPC8 Cell Mode

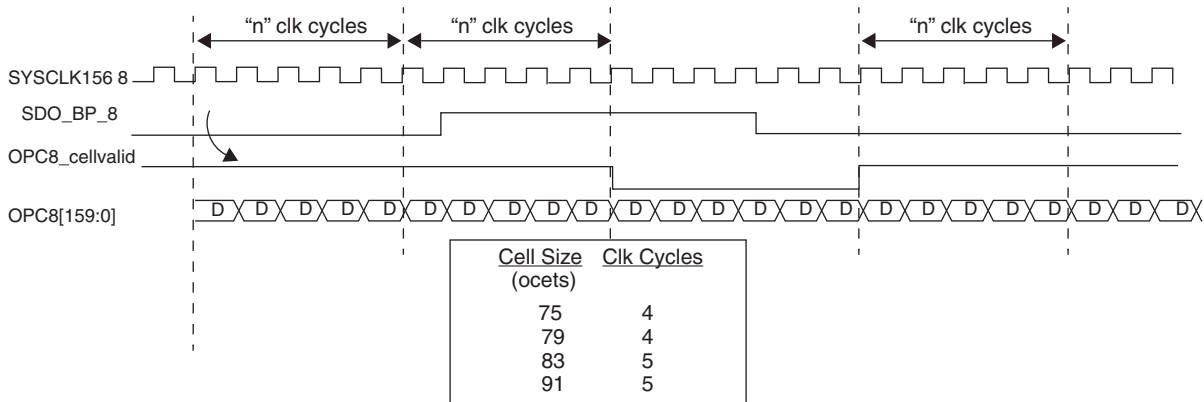

Cell Mode Receive Path

The receive logic blocks unique to the cell mode are shown in Figure 43 and are described in the next sections. Prior to reaching this logic the received data has been demultiplexed, frame aligned and descrambled by the SERDES and SONET logic and is formatted on a per channel basis as 32-bit words with an accompanying clock. The clock is a 77.76 MHz clock provided by the DEMUX block performing a divide-by-4 operation on RWCKxx.

The Data Extractor and receive FIFO (RXFIFO) process the data on a per channel basis. The receive FIFO also performs a clock domain transfer to the 156 MHz domain of the Input Port Controller (IPC2/8) blocks. The IPC2/8 blocks perform the two-link or eight-link (ORSO82G5 only) alignment functions. In two-link alignment mode, the received data are passed to the FPGA logic as 40-bit words at the 156 MHz rate. In eight-link alignment mode, the received data are passed to the FPGA logic as a single 160-bit word, again at the 156 MHz rate. Additional mode-dependent status information is also provided across the Core/FPGA interface.

Figure 43. Receive Path Logic Unique to Cell Mode

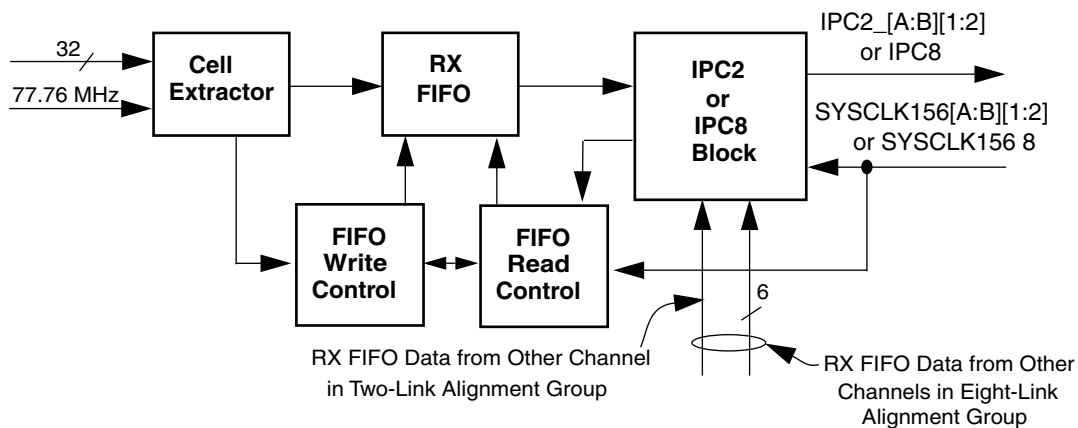

Cell Extractor

This block is used only in cell mode and does the following:

- Extracts User cells from the SPE
- Performs BIP calculation/checks to verify cell integrity
- Link Header Sequence Interrogation

Processing options include:

- Cell handling for invalid sequence (drop or pass to FPGA)
- S/W configurable 'link removal' due to excessive sequence errors

Data from the cell extractor block(s) is sent to the receive FIFO which aligns the data to the system clock domain and provides for deskew between the links.

Cell Extraction and BIP Calculation/Checking

The data from the descrambler are passed into the data extractor which strips the cell data from the payload of a SONET frame. The block extracts the BIP value from the data stream and also perform an internal cell BIP calculation. If the BIP value is not correct, an error flag bit will set in the status registers. The block also determines when the next Link Header is coming in the frame and what the cell sequence number contained within it should be. If the value of the cell sequence counter is not equal to the expected value, an error flag bit will set in the status registers and an error signal will be sent across the core/FPGA interface.

Link Header Detector

The Link Header detector determines when the next Link Header is coming in the frame and what the sequence number contained within it should be. If the value of the cell sequence counter is not equal to the expected value, then an error flag bit will set in the status registers and an error signal will be sent to the FPGA logic. The sequence counter will increment to the next sequence number. The sequence count value is NOT updated with the incorrect value, but is incremented each time a Link Header is received.

If excessive sequence errors are detected (three or more in a row), and the `AUTO_REMOVE_[A:B]` register bit is set, then the corresponding link will be treated as not valid. The `RX_LINK_GOOD` status bit will go low indicating the link is no longer receiving cells. If the `AUTO_REMOVE_[A:B]` register bit is not set, then the link is still valid when excessive sequence errors are detected. An OOF condition will also trigger the link to be removed from service if the `AUTO_REMOVE_[A:B]` register bit is set.

At startup or after a link has been removed from service (indicated by `RX_LINK_GOOD` going low), a link can be rejoined into the group. This is performed via the per block `REJOIN_[A:B]` register bit. When rejoining a link the RX FIFO will begin receiving cells. To cleanly rejoin a link into a group there are two methods to insure the RX FIFO begins loading correctly. The first method is to use the fast framing mode during the rejoin process. This can be done by setting the `FFRM_EN_xx` for the links that need to be rejoined before setting the `REJOIN_[A:B]` bit.

The second method is to issue a block reset to clear the FIFO once all links that have been selected to be rejoined are rejoined. This is done by first setting the `REJOIN_[A:B]` bit. Once the `RX_LINK_GOOD` status bit is high for the selected channels the `GSWRST_[A:B]` for the block should be set and cleared to reset the block. This method will disturb traffic on all links in the block during the `GSWRST_[A:B]` reset time.

Once all of the links in a group are rejoined and the traffic is again flowing the `REJOIN_[A:B]` bit should be cleared. If this bit is not cleared, a link may drop out using the `AUTO_REMOVE` mode and the channel may be rejoined incorrectly, causing errors on the entire group.

Receive FIFO

The main clock domain transfer for the data path is handled by the receive FIFO. A 16 x 161 FIFO is used in cell mode. The FIFO is implemented as a dual-port memory which will support simultaneous reads and writes. The receive FIFO block is written to at 77.76 MHz and read at 156 MHz.

The receive FIFO can allow for inter-link skew of about 800 ns ($16 \times 160 = 2560$ bits, 400 ps per bit gives 1024 ns). The 160 LSBs in the memory are received data and the 161st bit indicates the start of a new cell. The FIFO write control logic indicates to the IPC, the start of a new frame of data. This signal will only be active for the A1 word of a frame.

Once frame synchronization has occurred and the IPC has responded with a FIFO enable signal, data will be written into the memory. Only the payload (cells) is written to the FIFO. The TOH bytes are not written into the FIFO. The cell octets immediately following the A1A2 bytes will be always written to the top of the FIFO.

Once a full cell has been written to the memory, the write control logic will send a control signal to the IPC8 or IPC2 block which will start the process of reading data from the FIFO. The IPC will read one whole cell at a time from each of the 8 FIFO blocks, if configured for the eight-link cell mode (ORSO82G5 only) or from each of 2 FIFO blocks if configured for the two-link cell mode.

A FIFO occupancy counter generates a `RX_FIFO_OVRUN` indication to the register interface if it detects a FIFO overflow condition. The cell mode allows for alignment of all eight-links or alignment of two-links. Thus there will be two IPC blocks for two pairs of channels per block.

Input Port Controllers

The input port controllers (IPCs) are the block responsible for “directing traffic” for the receive traffic flow. The block diagrams for the 2-link and 8-link IPCs are shown in Figure 44. They provide the following essential functions.

- Determining when cell data can be read from the FIFOs of the individual links.

- Insuring group bundles are properly aligned.
- Scheduling reads from the RX FIFOs. Cells are read one at a time from the configured links.
- Parsing the cell data into payload data (along with selected header information). Cells which have errors that make them unusable (such as BIP or sequence number errors) are thrown away. This dropping of errored cells can be disabled through register bits CELL_BIP_INH_xx and CELL_SEQ_INX_xx.

Figure 44. IPC2 and IPC8 Block Diagrams

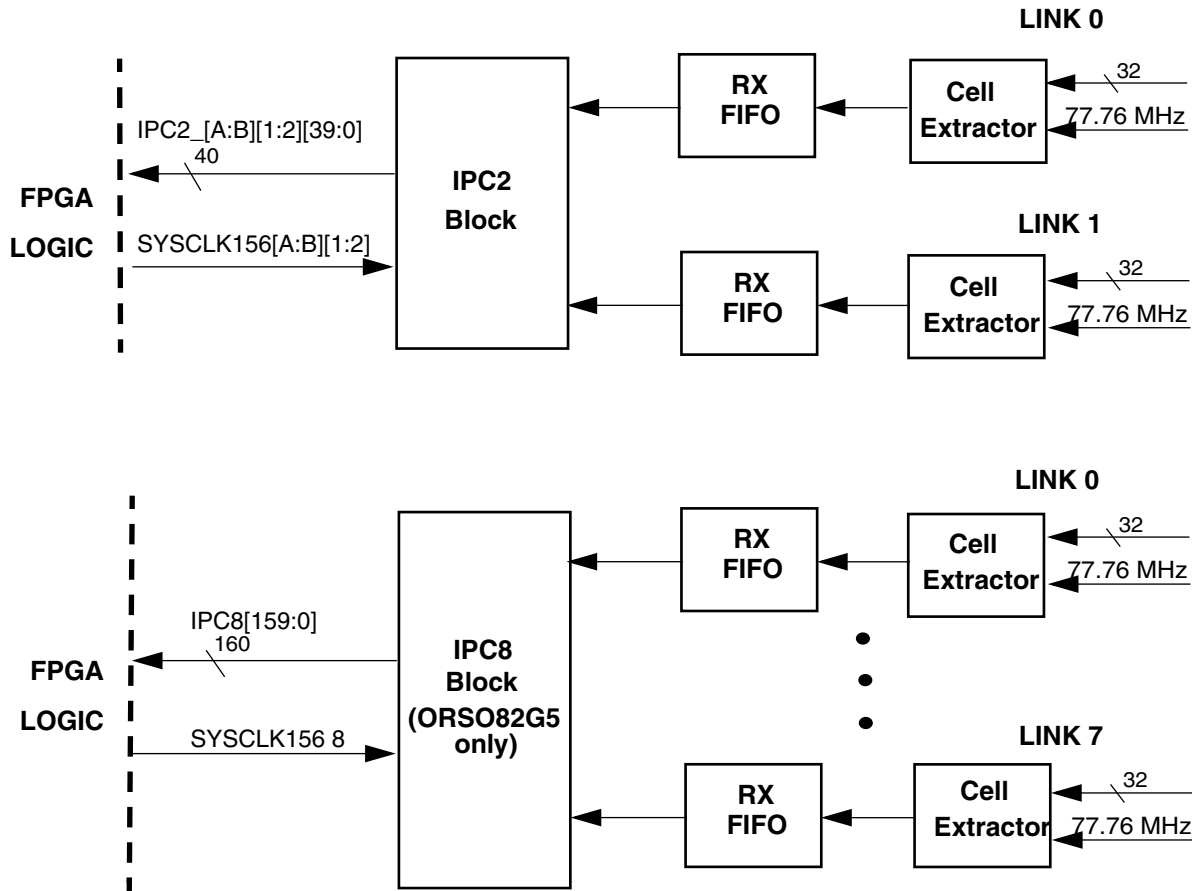

There are 5 IPC blocks in the embedded core. There is an IPC2 block for every channel pair:

- IPC2_A1 combines links from channels AA,AB (ORSO82G5 only)
- IPC2_A2 combines links from channels AC,AD
- IPC2_B1 combines links from channels BA,BB (ORSO82G5 only)
- IPC2_B2 combines links from channels BC,BD

The IPC8 block combines cells from all eight aligned links and transmits them to the FPGA logic (ORSO82G5 only).

Before an IPC can begin reading data from the Rx FIFOs and assembling cells, it must first align all FIFOs in a port bundle. This is accomplished by handshaking signals between the framer and the IPC. The framer indicates to the IPC that framing has been acquired. The framer does not start filling the FIFOs, however, until the next A1/A2 SONET signal.

The behavior of the IPC is dependent on the AUTO_BUNDLE register bit. If AUTO_BUNDLE is set, the group will continue to operate even if a link (or several links) of the group is not valid (RX_LINK_GOOD is low). If AUTO_BUNDLE is not set the entire group must be valid (RX_LINK_GOOD is high) for the group to receive cells through the IPC.

The IPC must determine when FIFO reads may begin. Before reading data from a FIFO can begin, the FIFO must have a full cell available to be read. This condition is indicated by a signal from each FIFO which is monitored by the IPC. The IPC then makes sure that the cells in a given port are received in the order that they are transmitted.

IPC Receive Cell Mode Timing Core/FPGA

This section contains timing diagrams for major interfaces of this block to the FPGA logic when cells are to be transferred. Figure 45 shows the cell twin-link mode timing. The number of clock cycles to transfer the cell data depends on the payload size selected. Error indications for CELL BIP errors and CELL DROP are also shown.

Figure 45. IPC2 Data Flow

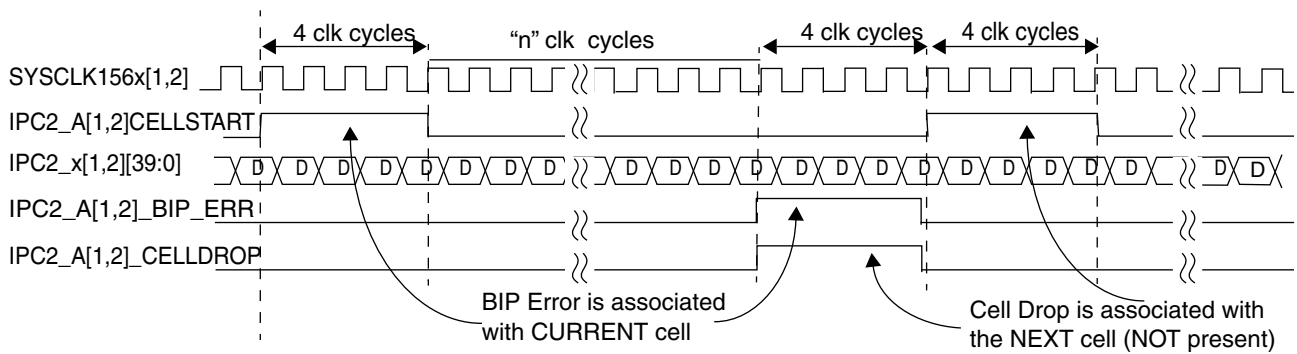

CELL BIP ERROR

If a Cell BIP Error occurs, the CELL_BIP_ERR signal reflects the occurrence, as shown in the Figure.
For 2-Link CELL MODE, the CELL_BIP_ERR signal is asserted during the last 4 clock cycles of the receive cell.

CELL BIP ERROR

If a cell error occurs within the ASB and;
1. CELL_BIP_INH=0 ...Do not drop BIP errored cells (s/w selectable)
2. A BIP error occurs
The drop indicator will PRECEED the user cell that contains the BIP error. All data will be passed w/o modification.

When operating in CELL MODE, the IPC2 Block passes user cells as well as control and status signals to the user. Depending upon the configured CELL SIZE, cell transfers will take a variable number of SYSCLK156 cycles to be received across the interface. Data are always transferred across a 40-bit bus (5 octets per clock cycle). Figure 45 shows 16 clock cycles for a cell transfer. This corresponds to a User Cell size of 79 octets.

Figure 46 shows cell octal alignment mode timing for the ORSO82G5. When operating in CELL MODE, the IPC8 Block aligns all 8 channels of receive data on a FRAME basis. The IPC8 also passes user cells as well as control and status signals to the user. Depending upon the configured CELL SIZE, cell transfers will take a variable number of SYSCLK156 cycles to be received across the interface. Data are always transferred across an 160-bit bus (20 octets per clock cycle). Figure 46 shows 4 clock cycles for a cell transfer. This corresponds to a User Cell size of 79 octets.

Figure 46. ORSO82G5 Receive FPGA/Embedded Core Interface IPC8 Mode

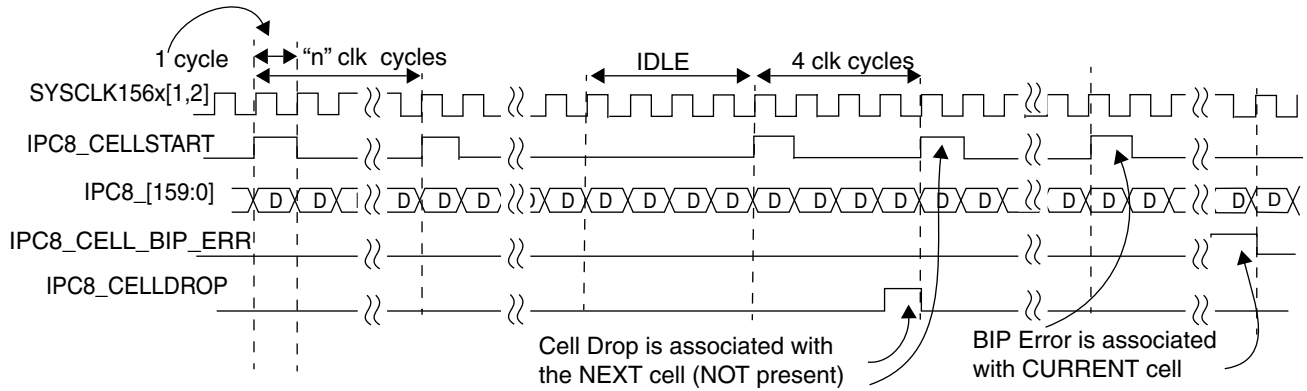

CELL BIP ERROR

If a Cell BIP Error occurs, the CELL_BIP_ERR signal reflects the occurrence, as shown in the figure.

CELL BIP ERROR

If a cell error occurs within the ASB and;

1. CELL_BIP_INH=0 (Do not drop BIP errored cells)
2. A BIP error occurs

The drop indicator will PRECEED the user cell that contains the BIP error. All data will be passed w/o modification.

In the SERDES-only mode the data are simply transferred as 32-bit wide words to and from the FPGA logic. The next sections describe the signal definitions for the TX and RX paths in the SONET, OPC2 and OPC8 modes. The signal names unique to an operating mode are preferred for design and are generally the ones used in the ispLEVER design environment. The labels in the left most column are the hardware FPGA interface names. The ispLEVER software creates an HDL module with specific names based on the mode selected for each channel. The pin mappings performed by ispLEVER are shown in Table 11 through Table 14.

The interface signals for the embedded RAM are completely independent of these signals. The memory signals are described in a later section.

Signal Description for TX Path (FPGA to SERDES Core) – ORSO42G5

- Signals are divided across four channels with 40 signals per channel. TXDxx[39:0] is the set of 40 signals for a channel xx.
- The data signals multiplexing scheme is similar to the one used for the RXD signals. However, the status signals multiplexing is different. Please refer to Table 11 for a detailed description of the TXD multiplexing scheme.
- For all channels the TXDxx[39:33] signals are not used.

Table 11 summarizes the signals at the FPGA/Core interface in the transmit direction.

Table 11. TX FPGA/Core Interface Signaling – ORSO42G5

| TXDAC | SONET Mode | OPC2 A2 Mode |
|---------|--------------|-------------------|
| [39:33] | — | — |
| 32 | DINAC_FP | — |
| [31:21] | DINAC[31:21] | — |
| 20 | DINAC[20] | OPC2_A2_CELLVALID |
| [19:0] | DINAC[19:0] | OPC2_A2[39:20] |
| | | |
| TXDAD | SONET Mode | OPC2 A2 Mode |
| [39:33] | — | — |
| 32 | DINAD_FP | — |
| [31:21] | DINAD[31:21] | — |
| 20 | DINAD[20] | — |
| [19:0] | DINAD[19:0] | OPC2_A2[19:0] |

Signal Description for TX Path (FPGA to SERDES Core) – ORSO82G5

- Signals are divided across 8 channels with 40 signals per channel. TXDxx[39:0] is the set of 40 signals for a channel xx.
- The data signals multiplexing scheme is similar to the one used for the RXD signals. However, the status signals multiplexing is different. Please refer to Table 12 for the detailed description of the TXD multiplexing scheme.
- For all channels the TXDxx[39:33] signals are not used.

Table 12 summarizes the signals at the FPGA/Core interface in the transmit direction.

Table 12. TX FPGA/Core Interface Signaling – ORSO82G5

| TXDAA | SONET Mode | OPC2 A1 Mode | OPC8 Mode |
|---------|--------------|-------------------|----------------|
| [39:33] | — | — | — |
| 32 | DINAA_FP | — | — |
| [31:21] | DINAA[31:21] | — | — |
| 20 | DINAA[20] | OPC2_A1_CELLVALID | — |
| [19:0] | DINAA[19:0] | OPC2_A1[39:20] | OPC8[159:140] |
| | | | |
| TXDAB | SONET Mode | OPC2 A1 Mode | OPC8 Mode |
| [39:33] | — | — | — |
| 32 | DINAB_FP | — | — |
| [31:20] | DINAB[31:20] | — | — |
| [19:0] | DINAB[19:0]] | OPC2_A1[19:0]] | OPC8[139:120]] |
| | | | |
| TXDAC | SONET Mode | OPC2 A2 Mode | OPC8 Mode |
| [39:33] | — | — | — |
| 32 | DINAC_FP | — | — |
| [31:21] | DINAC[31:21] | — | — |
| 20 | DINAC[20] | OPC2_A2_CELLVALID | — |
| [19:0] | DINAC[19:0] | OPC2_A2[39:20] | OPC8[119:100] |
| | | | |
| TXDAD | SONET Mode | OPC2 A2 Mode | OPC8 Mode |

Table 12. TX FPGA/Core Interface Signaling – ORSO82G5 (Continued)

| | | | |
|--------------|-------------------|---------------------|------------------|
| [39:33] | — | — | — |
| 32 | DINAD_FP | — | — |
| [31:21] | DINAD[31:21] | — | — |
| 20 | DINAD[20] | — | OPC8_CELLVALID |
| [19:0] | DINAD[19:0] | OPC2_A2[19:0] | OPC8[99:80] |
| TXDBA | SONET Mode | OPC2 B1 Mode | OPC8 Mode |
| [39:33] | — | — | — |
| 32 | DINBA_FP | — | — |
| [31:21] | DINBA[31:21] | — | — |
| 20 | DINBA[20] | OPC2_B1_CELLVALID | — |
| [19:0] | DINBA[19:0] | OPC2_B1[39:20] | OPC8[79:60] |
| TXDBB | SONET Mode | OPC2 B1 Mode | OPC8 Mode |
| [39:33] | — | — | — |
| 32 | DINBB_FP | — | — |
| [31:20] | DINBB[31:20] | — | — |
| [19:0] | DINBB[19:0] | OPC2_B1[19:0] | OPC8[59:40] |
| TXDBC | SONET Mode | OPC2 B2 Mode | OPC8 Mode |
| [39:33] | — | — | — |
| 32 | DINBC_FP | — | — |
| [31:21] | DINBC[31:21] | — | — |
| 20 | DINBC[20] | OPC2_B2_CELLVALID | — |
| [19:0] | DINBC[19:0] | OPC2_B2[39:20] | OPC8[39:20] |
| TXDBD | SONET Mode | OPC2 B2 Mode | OPC8 Mode |
| [39:33] | — | — | — |
| 32 | DINBD_FP | — | — |
| [31:20] | DINBD[31:20] | — | — |
| [19:0] | DINBD[19:0] | OPC2_B2[19:0] | OPC8[19:0] |

Signal Description for RX Path (SERDES Core to FPGA) – ORSO42G5

- Signals are divided across four channels with 40 signals per channel. RXDxx[39:0] is the set of 40 signals for a channel xx.
- All RX direction signals are outputs from the core.
- See Figure 47 for clock transfers across the FPGA/Core interface.
- In SONET mode, RXDxx[31:0] carries 32 bit data from the alignment FIFO of the respective channel. RXDxx[35:32] carries miscellaneous information such as OOF, BIPERR, Frame Pulse (FP), and SPE.
- In cell mode, data from each of the four 2-link IPC bundles are spread across all eight channels and are assigned to the 20 LSBs (RXDxx[19:0]) of each channel output. Data from IPC2_A1 is distributed across RXDAA[19:0] and RXDAB[19:0]. Data from IPC2_A2 is distributed across RXDAC[19:0] and RXDAD[19:0]. This symmetry is maintained for IPC2 data signals from block B.
- The IPC status signals for Cell Mode operation are contained in RXDxx[39:36] and RXDxx[33].
- The signals for SONET Mode operation are assigned to RXDxx[35:34] and RXDxx[33].

- Note that RXDxx[39:32] signal assignments are the same no matter what mode the RX blocks are in.

Table 13 summarizes the signals across the Core/FPGA interface in the receive direction.

Table 13. RX Core/FPGA Interface Signals – ORSO42G5

| RXDAC[39:0] | SONET mode | IPC2 A2 Mode |
|--------------|---------------|----------------------|
| 39 | SYNC2_A2_OOS | — |
| 38 | — | IPC2_A2_CELLDROP |
| 37 | — | IPC2_A2_CELLSTART |
| 36 | DOUTAC_FP | — |
| 35 | DOUTAC_OOF | |
| 34 | DOUTAC_SPE | — |
| 33 | — | IPC2_A2_CELL_BIP_ERR |
| 32 | DOUTAC_B1_ERR | |
| [31:20] | DOUTAC[31:20] | — |
| [19:0] | DOUTAC[19:0] | IPC2_A2[39:20] |
| | | |
| RXDAD[39:0] | SONET Mode | IPC2 A2 Mode |
| 39 | — | — |
| 38 | — | — |
| 37 | — | CELL_BEGIN_OK_A2 |
| 36 | DOUTAD_FP | — |
| 35 | DOUTAD_OOF | |
| 34 | DOUTAD_SPE | — |
| 33 | — | — |
| 32 | DOUTAD_B1_ERR | |
| [31:20] | DOUTAD[31:20] | — |
| [19:0] | DOUTAD[19:0] | IPC2_A2[19:0] |
| | | |
| RXDABC[39:0] | SONET Mode | IPC2 B2 Mode |
| 39 | SYNC2_B2_OOS | — |
| 38 | — | IPC2_B2_CELLDROP |
| 37 | — | IPC2_B2_CELLSTART |
| 36 | DOUTBC_FP | — |
| 35 | DOUTBC_OOF | |
| 34 | DOUTBC_SPE | — |
| 33 | — | IPC2_B2_CELL_BIP_ERR |
| 32 | DOUTBC_B1_ERR | |
| [31:20] | DOUTBC[31:20] | — |
| [19:0] | DOUTBC[19:0] | IPC2_B2[39:20] |
| | | |
| RXDABD[39:0] | SONET Mode | IPC2 B2 Mode |
| 39 | — | — |
| 38 | SYNC4_B_OOS | — |
| 37 | — | CELL_BEGIN_OK_B2 |
| 36 | DOUTBD_FP | — |
| 35 | DOUTBD_OOF | |
| 34 | DOUTBD_SPE | — |

Table 13. RX Core/FPGA Interface Signals – ORSO42G5 (Continued)

| | | |
|---------|---------------|---------------|
| 33 | — | |
| 32 | DOUTBD_B1_ERR | |
| [31:20] | DOUTBD[31:20] | — |
| [19:0] | DOUTBD[19:0] | IPC2_B2[19:0] |

Signal Description for RX Path (SERDES Core to FPGA) – ORSO82G5

- Signals are divided across 8 channels with 40 signals per channel. RXDxx[39:0] is the set of 40 signals for a channel xx.
- All RX direction signals are outputs from the core.
- See Figure 47 for clock transfers across the FPGA/Core interface.
- In SONET mode, RXDxx[31:0] carries 32 bit data from the alignment FIFO of the respective channel. RXDxx[35:32] carries miscellaneous information such as OOF, BIPERR, Frame Pulse (FP), and SPE.
- In cell mode, data from each of the four 2-link IPC bundles are spread across all eight channels and are assigned to the 20 LSBs (RXDxx[19:0]) of each channel output. Data from IPC2_A1 is distributed across RXDAA[19:0] and RXDAB[19:0]. Data from IPC2_A2 is distributed across RXDAC[19:0] and RXDAD[19:0]. This symmetry is maintained for IPC2 data signals from block B.
- Data from the 8-link IPC block IPC8 is spread across all eight channels and assigned to the 20 LSB's (RXDxx[19:0]) of each channel output.
- The IPC status signals for Cell Mode operation are contained in RXDxx[39:36] and RXDxx[33].
- The signals for SONET Mode operation are assigned to RXDxx[35:34] and RXDxx[33].
- Note that RXDxx[39:32] signal assignments are the same no matter what mode the RX blocks are in.

Table 14 summarizes the signals across the Core/FPGA interface in the receive direction.

Table 14. RX Core/FPGA Interface Signals – ORSO82G5

| RXDAA[39:0] | SONET mode | IPC2 A1 Mode | IPC8 Mode |
|-------------|---------------|----------------------|-----------|
| 39 | SYNC2_A1_OOS | — | — |
| 38 | — | IPC2_A1_CELLDROP | — |
| 37 | — | IPC2_A1_CELLSTART | — |
| 36 | DOUTAA_FP | — | — |
| 35 | DOUTAA_OOF | | |
| 34 | DOUTAA_SPE | — | — |
| 33 | — | IPC2_A1_CELL_BIP_ERR | — |
| 32 | DOUTAA_B1_ERR | | |
| [31:20] | DOUTAA[31:20] | — | — |
| [19:0] | DOUTAA[19:0] | IPC2_A1[39:20] | — |
| | | | |
| RXDAB[39:0] | SONET mode | IPC2 A1 Mode | IPC8 Mode |
| 39 | — | — | — |
| 38 | SYNC4_A_OOS | — | — |
| 37 | — | CELL_BEGIN_OK_A1 | — |
| 36 | DOUTAB_FP | — | — |
| 35 | DOUTAB_OOF | | |
| 34 | DOUTAB_SPE | — | — |

Table 14. RX Core/FPGA Interface Signals – ORSO82G5 (Continued)

| | | | |
|-------------|----------------|----------------------|-------------------|
| 33 | — | | |
| 32 | DOUTAB_B1_ERR | | |
| [31:20] | DOUTAB[31:20]] | — | |
| [19:0] | DOUTAB[19:0] | IPC2_A1[19:0] | IPC8[139:120] |
| RXDAC[39:0] | SONET mode | IPC2 A2 Mode | IPC8 Mode |
| 39 | SYNC2_A2_OOS | — | |
| 38 | — | IPC2_A2_CELLDROP | — |
| 37 | — | IPC2_A2_CELLSTART | — |
| 36 | DOUTAC_FP | — | |
| 35 | DOUTAC_OOF | | |
| 34 | DOUTAC_SPE | — | |
| 33 | — | IPC2_A2_CELL_BIP_ERR | — |
| 32 | DOUTAC_B1_ERR | | |
| [31:20] | DOUTAC[31:20]] | — | |
| [19:0] | DOUTAC[19:0] | IPC2_A2[39:20] | IPC8[119:100] |
| RXDAD[39:0] | SONET Mode | IPC2 A2 Mode | IPC8 Mode |
| 39 | — | — | IPC8_CELLDROP |
| 38 | — | — | IPC8_CELLSTART |
| 37 | — | CELL_BEGIN_OK_A2 | — |
| 36 | DOUTAD_FP | — | |
| 35 | DOUTAD_OOF | | |
| 34 | DOUTAD_SPE | — | |
| RXDAD[39:0] | SONET Mode | IPC2 A2 Mode | IPC8 Mode |
| 33 | — | — | IPC8_CELL_BIP_ERR |
| 32 | DOUTAD_B1_ERR | | |
| [31:20] | DOUTAD[31:20] | — | |
| [19:0] | DOUTAD[19:0] | IPC2_A2[19:0] | IPC8[99:80] |
| RXDBA[39:0] | SONET Mode | IPC2 B1 Mode | IPC8 Mode |
| 39 | SYNC2_B1_OOS | — | |
| 38 | — | IPC2_B1_CELLDROP | — |
| 37 | — | IPC2_B1_CELLSTART | — |
| 36 | DOUTBA_FP | — | |
| 35 | DOUTBA_OOF | | |
| 34 | DOUTBA_SPE | — | |
| 33 | — | IPC2_B1_CELL_BIP_ERR | — |
| 32 | DOUTBA_B1_ERR | | |
| [31:20] | DOUTBA[31:20] | — | |
| [19:0] | DOUTBA[19:0] | IPC2_B1[39:20] | IPC8[79:60] |
| RXDBB[39:0] | SONET Mode | IPC2 B1 Mode | IPC8 Mode |
| 39 | SYNC8_OOS | — | |
| 38 | — | — | SDO_BP_8 |

Table 14. RX Core/FPGA Interface Signals – ORSO82G5 (Continued)

| | | | |
|-------------|---------------|----------------------|-------------|
| 37 | — | CELL_BEGIN_OK_B1 | — |
| 36 | DOUTBB_FP | — | |
| 35 | DOUTBB_OOF | | |
| 34 | DOUTBB_SPE | — | |
| 33 | — | | |
| 32 | DOUTBB_B1_ERR | | |
| [31:20] | DOUTBB[31:20] | — | |
| [19:0] | DOUTBB[19:0] | IPC2_B1[19:0] | IPC8[59:40] |
| RXDBC[39:0] | SONET Mode | IPC2 B2 Mode | IPC8 Mode |
| 39 | SYNC2_B2_OOS | — | |
| 38 | — | IPC2_B2_CELLDROP | — |
| 37 | — | IPC2_B2_CELLSTART | — |
| 36 | DOUTBC_FP | — | |
| 35 | DOUTBC_OOF | | |
| 34 | DOUTBC_SPE | — | |
| 33 | — | IPC2_B2_CELL_BIP_ERR | — |
| 32 | DOUTBC_B1_ERR | | |
| [31:20] | DOUTBC[31:20] | — | |
| [19:0] | DOUTBC[19:0] | IPC2_B2[39:20] | IPC8[39:20] |
| RXDBD[39:0] | SONET Mode | IPC2 B2 Mode | IPC8 Mode |
| 39 | — | | |
| 38 | SYNC4_B_OOS | — | |
| 37 | — | CELL_BEGIN_OK_B2 | — |
| 36 | DOUTBD_FP | — | |
| 35 | DOUTBD_OOF | | |
| 34 | DOUTBD_SPE | — | |
| 33 | — | | |
| 32 | DOUTBD_B1_ERR | | |
| [31:20] | DOUTBD[31:20] | — | |
| [19:0] | DOUTBD[19:0] | IPC2_B2[19:0] | IPC8[19:0] |

Reference Clock Requirements

There are two pairs of reference clock inputs in the ORSO42G5 and ORSO82G5 devices. Each reference clock is distributed to all channels in a block. Each channel has a differential buffer to isolate the clock from the other channels. The input clock is preferably a differential signal; however, the device can operate with a single-ended input. The input reference clock directly impacts the transmit data eye, so the clock should have low jitter. In particular, jitter components in the DC to 5 MHz range should be minimized. The required electrical characteristics for the reference clock are given in Table 46.

Synthesized and Recovered Clocks

The SERDES Embedded Core block contains its own dedicated PLLs for transmit and receive clock generation. The user provides a reference clock of the appropriate frequency, as described in the previous section. The transmitter PLL uses the REFCLK_[A,B] inputs to synthesize the internal high-speed serial bit clocks. The receiver PLLs extract the clock from the serial input data and retime the data with the recovered clock.

The receive PLL for each channel has two modes of operation - lock to reference and lock to data with retiming. When no data or invalid data is present on the HDINP_xx and HDINN_xx pins, the receive VCO will not lock to data and its frequency can drift outside of the nominal ± 100 ppm range. Under this condition, the receive PLL will lock to REFCLK_[A,B] for a fixed time interval and then will attempt to lock to receive data. The process of attempting to lock to data, then locking to clock will repeat until valid input data exists. There is also a control register bit per channel to force the receive PLL to always lock to the reference clock.

The high-speed transmit and receive serial data links can run at 0.6 to 2.7 Gbps, depending on the frequency of the reference clock and the state of the control bits from the internal transmit control register. The interface to the serializer/deserializer block runs at 1/8th the bit rate of the data lane. Additionally, the MUX/DEMUX logic converts the data rate and bit-width so the FPGA core can run at 1/4th this frequency which gives a range of 18.8 to 84.4 MHz for the data in and out of the FPGA in SONET mode. In cell mode, there is a clock domain transfer to a 2x clock domain, which gives a range of 37.5 to 168.8 MHz for the data in and out of the FPGA.

Internal Clock Signals at the FPGA/Core Interface

There are several clock signals defined at the FPGA/Embedded Core interface in addition to the external reference clock for each SERDES block. All of the ORSO42G5 and ORSO82G5 clock signals are shown in Figure 47 and are described following the figure.

Figure 47. ORSO42G5 and ORSO82G5 Clock Signals, Block A (High speed serial I/O also shown. Block B has the same signals, SYSCLK156 8 is unique to the ORSO82G5 and common to both blocks).

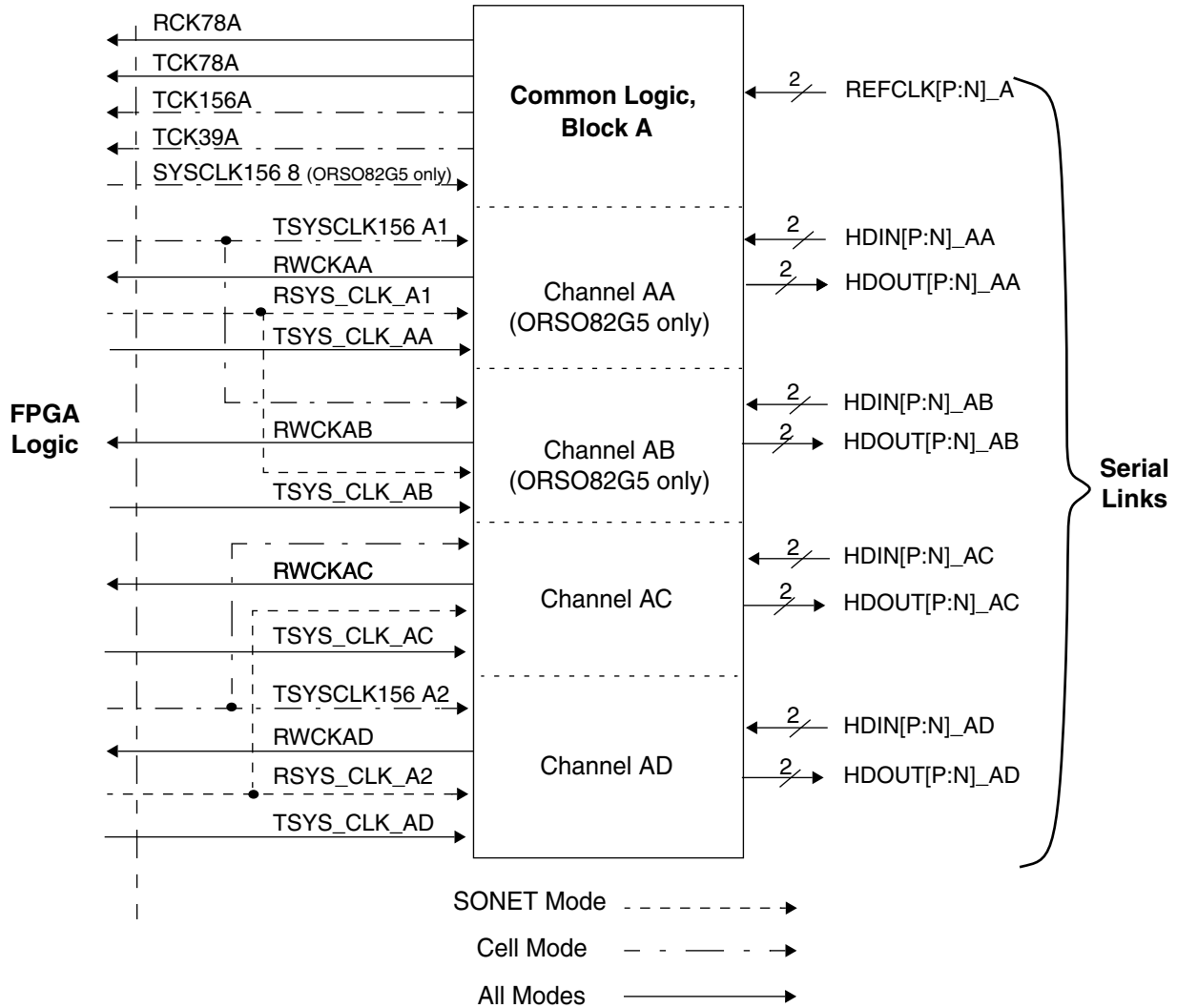

REFCLKP [A:B], REFCLKN [A:B]: These are the differential reference clocks provided to the ORSO42G5 and ORSO82G5 device as described earlier. They are used as the reference clock for both TX and RX paths. For operation of the serial links at 2.48 Gbps, the reference clocks will be at a frequency of 155.52 MHz.

RWCK[AA:BD]: These are the low-speed receive clocks from the embedded core to the FPGA across the core-FPGA interface. These are derived from the recovered low-speed complementary clocks from the SERDES blocks. RWCKAA belongs to Channel AA, RWCKAB belongs to channel AB and so on. With a reference clock input of 155.52 MHz, these clocks operate at 77.76 MHz.

RCK78[A:B]: These are muxed outputs of RWCKA[A:D] and RWCKB[B:D] respectively. With a reference clock input of 155.52 MHz, these clocks operate at 77.76 MHz.

RSYSCLK[A:B][1:2]: These clocks are inputs to the SERDES block A and B respectively from the FPGA. These are used by each channel as the read clock to read received data from the alignment FIFO within the embedded core. Clocks RSYSCLKA[1:2] are used by channels in the SERDES block A and RSYSCLKB[1:2] by channels in the SERDES block B. To guarantee that there is no overflow in the alignment FIFO, it is an absolute requirement that the write and read clocks be frequency locked within 0 ppm. Examples of how to achieve this are shown in the later section on recommended board-level clocking.

TCK156[A:B]: This is a muxed output from the core to the FPGA across the core-FPGA interface of one of the 4 transmit SERDES clocks per block. There is one clock output per SERDES block. It is derived from REFCLK_[A:B] and runs at the reference clock frequency. This clock is available from the core in all modes and used by the core in cell mode.

TCK78[A:B]: This is a muxed output from the core to the FPGA across the core-FPGA interface of one of the 4 transmit SERDES clocks per block. There is one clock output per SERDES block. It is derived from REFCLK_[A:B] and runs at half the reference clock frequency. This clock is available from the core in all modes and used by the core in SONET and SERDES-only mode.

TCK39[A:B]: This is a muxed output from the core to the FPGA across the core-FPGA interface of one of the 4 transmit SERDES clocks per block. There is one clock output per SERDES block. It is derived from REFCLK_[A:B] and runs at a quarter of the reference clock frequency. This clock is available from the core in all modes.

TSYSCLK[AA,...BD]: These clocks are inputs to the SERDES block A and B respectively from the FPGA. These are used by each channel to control the timing of the Transmit Data Path in the SONET and SERDES-only modes. (They are not used in cell mode.) To guarantee correct transmit operation these clocks must be frequency locked within 0 ppm to TCK78[A:B].

SYCLK156 [A:B][1:2] and SYCLK156 8: These clocks are inputs to the SERDES block A and B from the FPGA, and are used by the cell processing blocks within the embedded core. Clocks SYCLK156 A[1:2] are used by channels in the SERDES block A and SYCLK156 B[1:2] by channels in the SERDES block B for two-link cell mode operation. SYCLK156 8 is used by both blocks for eight-link cell mode in the ORSO82G5.

Sample Initialization Sequences – ORSO42G5

The following paragraphs show sample control register write sequences for initialization and resynchronization for the major modes of the device. Hexadecimal values will be shown for the data to be written into the control registers. For these values bit 0 will be the MSb while bit 7 is the LSb. For the per-channel control registers, only the first register address is shown. The other per-channel control registers must also be initialized for the desired mode.

1. SERDES-Only Mode Initialization – ORSO42G5

- Set SERDES Only mode (per channel, channel AA selected for sample initialization)
 - 30823 and 30833 40
- Set SERDES PLL to Lock to Data signal (per channel, channel AA selected for sample initialization)
 - 30824 and 30834 80
- Toggle SOFT_RESET once all clocks have stabilized
 - 30A06 01
 - 30A06 00
- Provide a rising edge on the DINxx_START signal

2. SONET Mode Initialization – ORSO42G5

This sample initialization uses the alignment FIFO for two channel alignment and Auto_SOH mode

- Set Dual Channel Alignment (per channel, channels AC and AD)
 - 30822 and 30833 10
- Set SERDES PLL to Lock to Data signal (per channel, channels AC and AD)
 - 30824 and 30834 80
- Set Auto_SOH Mode (per channel, channels AC and AD)
 - 30826 and 30836 03

- Toggle SOFT_RESET once all clocks have stabilized
 - 30A06 01
 - 30A06 00

3. SONET Alignment FIFO Resynchronization – ORSO42G5

If during operation a link goes OOF the alignment group will continue to run without the errored channel. To realign this link with the rest of group once the OOF condition is cleared the group may need to be resynchronized. This operation (for 4 channel alignment in block A) is shown below.

- Toggle the FMPU_RESYNC2_A2 register bit to reset the alignment FIFO group.
 - 30A04 04
 - 30A04 00

This sequence will stop traffic temporarily on all links in the alignment grouping.

4. Two-Link Cell Mode Initialization – ORSO42G5

This sample initialization uses 2-link cell mode on all links (A1, A2, B1, and B2). Auto_Bundle and Auto_Remove are both used for these links. The GSWRST_[A:B] Rejoin method is used.

- Set SERDES PLL to Lock to Data signal and Auto_TOH mode (per channel, all channels)
 - 30824 and 30834 82
- Enable Auto_Remove and Rejoin
 - 30A03 1B
- Set 2-link cell mode for groups A2 and B2
 - 30A05 0A
- Toggle SOFT_RESET
 - 30A06 01
 - 30A06 00
- Set the TX_CFG_DONE bit to indicate the transmitter is completely configured
 - 30A07 01
- Toggle GSWRST_[A:B] to clear the RX FIFOs
 - 30005 20
 - 30105 20
 - 30005 00
 - 30105 00
- Turn Off Rejoin (clear the Rejoin register bits) and enable Auto_Bundle
 - 30A03 49

Sample Initialization Sequences – ORSO82G5

The following paragraphs show sample control register write sequences for initialization and resynchronization for the major modes of the device. Hexadecimal values will be shown for the data to be written into the control registers. For these values bit 0 will be the MSb while bit 7 is the LSb. For the per-channel control registers, only the first register address is shown. The other per-channel control registers must also be initialized for the desired mode.

1. SERDES-Only Mode Initialization – ORSO82G5

- Set SERDES Only mode (per channel, channel AA selected for sample initialization)
 - 30803 40
- Set SERDES PLL to Lock to Data signal (per channel, channel AA selected for sample initialization)
 - 30804 80

- Toggle SOFT_RESET once all clocks have stabilized
 - 30A06 01
 - 30A06 00

- Provide a rising edge on the DIXxx_START signal

2. SONET Mode Initialization – ORSO82G5

This sample initialization uses the alignment FIFO for 4 channel alignment and Auto_SOH mode

- Set 4 Channel Alignment (per channel, all channels in block A)
 - 30802, etc. 60
- Set SERDES PLL to Lock to Data signal (per channel, all channels in block A)
 - 30804, etc. 80
- Set Auto_Soh Mode (per channel, all channels in block A)
 - 30806, etc. 03
- Set NO_TX_RDI_EXSEQ Global register (block A). This is required to stop cell mode blocks from sending RDI due to no cells.
 - 30A03 80
- Toggle SOFT_RESET once all clocks have stabilized
 - 30A06 01
 - 30A06 00

3. SONET Alignment FIFO Resynchronization – ORSO82G5

If during operation a link goes OOF the alignment group will continue to run without the errored channel. To realign this link with the rest of group once the OOF condition is cleared the group may need to be resynchronized. This operation (for 4 channel alignment in block A) is shown below.

- Toggle the FMPU_RESYNC4_4 register bit to reset the alignment FIFO group.
 - 30A04 48
 - 30A04 00

This sequence will stop traffic temporarily on all links in the alignment grouping.

4. Two-Link Cell Mode Initialization – ORSO82G5

This sample initialization uses 2-link cell mode on all links (A1, A2, B1, and B2). Auto_Bundle and Auto_Remove are both used for these links. The GSWRST_[A:B] Rejoin method is used.

- Set SERDES PLL to Lock to Data signal and Auto_TOH mode (per channel, all channels)
 - 30804, etc. 82
- Set Auto_Remove and Rejoin
 - 30A03 1B
- Set 2-link cell mode for all groups A1, A2, B1 and B2
 - 30A05 1E
- Toggle SOFT_RESET
 - 30A06 01
 - 30A06 00
- Set the TX_CFG_DONE bit to indicate the transmitter is completely configured
 - 30A07 01

- Toggle GSWRST_[A:B] to clear the RX FIFOs
 - 30005 20
 - 30105 20
 - 30005 00
 - 30105 00
- Clear the Rejoin register bits and set Auto_Bundle
 - 30A03 49

5. Eight-Link Cell Mode Initialization – ORSO82G5

This sample initialization uses 8-link cell mode. Auto_Bundle and Auto_Remove are both used for these links. The GSWRST_[A:B] Rejoin method is used.

- Set SERDES PLL to Lock to Data signal and Auto_TOH mode (per channel, all channels)
 - 30804, etc. 82
- Set Auto_Remove, and Rejoin
 - 30A03 1B
- Set 8-link cell mode
 - 30A05 01
- Toggle SOFT_RESET
 - 30A06 01
 - 30A06 00
- Set the TX_CFG_DONE bit to indicate the transmitter is completely configured
 - 30A07 01
- Toggle GSWRST_[A:B] to clear the Rx FIFOs
 - 30005 20
 - 30105 20
 - 30005 00
 - 30105 00
- Once all of the RX_LINK_GOODs are high, Clear the Rejoin register bits and set Auto_Bundle
 - 30A03 49

Reset Conditions

The SERDES block can be reset in one of three different ways: on power up, using the hardware reset (PASB_RESETN) or by setting bits in the control registers. The power up reset process begins when the power supply voltage ramps up to approximately 80% of the nominal value of 1.5V. Following this event, the device will be ready for normal operation after 3 ms.

A hardware reset is initiated by making the PASB_RESETN low for at least two microprocessor clock cycles. The device will be ready for operation 3 ms after the low to high transition of the PASB_RESETN. This reset function affects all SERDES blocks and resets all core control, status and data path registers and counters.

Using the software reset option, each channel can be individually reset by setting SWRST bit to a logic 1 in the SERDES channel configuration register. The device will be ready 3 ms after the SWRST bit is deasserted. Similarly, all four channels per block SERDES can be reset by setting the global reset bit GSWRST. The device will be ready for normal operation 3 ms after the GSWRST bit is deasserted. Note that the software reset options resets only the SERDES internal registers and counters on a per channel or per block basis. The core non-SERDES registers and logic blocks are not affected. It should also be noted that the embedded core registers and logic blocks cannot be accessed until after FPGA configuration is complete.

Table 15 summarizes the conditions under which the embedded core registers, SERDES, and embedded core logic are reset under user control. The embedded core status registers are also reset on read.

Table 15. ORSO42G5 and ORSO82G5 Embedded Core Reset Conditions

| Reset Signal | Data Paths | Control and Status Registers | TCK156[A:B] TCK78[A:B] TCK39[A:B] | RCK78[A:B] RWCKxx | Notes |
|---|------------------------|------------------------------|---|------------------------|---|
| Power up | Reset | Reset | Reset | Reset | Power on reset |
| PASB_RESETN pin = 0 (Hard Reset) | Reset | Reset | Reset | Reset | External input pin |
| FPGA Configuration | Reset | Reset | Reset | Reset | DONE pin = 0 |
| Partial FPGA Reconfiguration (with option disable TRI_IO) | — | — | — | — | DONE pin = 0 |
| Internal Signal FPGA_RESET = 1 | Reset | — | — | — | FPGA_RESET is FPGA sourced |
| FPGA GSRN signal = 0 | Optional | — | Optional | — | GSRN is FPGA sourced. Set GSRN_DISABLE = 1 to disable this reset |
| SOFT_RESET = 0, 1, 0 (System Bus register based) | Reset | — | Reset | — | write SOFT_RESET = 1 (ON) then write SOFT_RESET = 0 (OFF) |
| TS_ALL Pin = 1 | — | — | — | — | External input pin |
| SWRST_xx= 0,1,0 xx = [AC, AD, BA, BD] or [AA,...,BD] | Selected channel reset | — | Selected channel reset | Selected channel reset | Per channel software reset (Not self-clearing, must be manually set and cleared.) |
| GWRST_[A:B] = 0,1,0 | Selected block reset | — | Selected block reset | Selected block reset | Per block software reset (Not self-clearing, must be manually set and cleared.) |

SERDES Characterization Test Mode (ORSO82G5 Only)

The SERDES characterization mode is a test mode that allows for direct control and observation of the transmit and receive SERDES interfaces at chip ports. With these modes the SERDES logic and I/O can be tested one channel at a time in either the receive or transmit modes. The SERDES characterization mode is available for only one block (block B) of the ORSO82G5.

The characterization test mode is configured by setting bits in the control registers via the system bus. There are four bits that set up the test mode. The transmit characterization test mode is entered when SCHAR_ENA=1 and SCHAR_TXSEL=1. Entering this mode will cause chip port inputs to directly control the SERDES low-speed transmit ports of one of the channels as shown in Table 16.

Table 16. SERDES Transmit Characterization Mode

| Chip Port | SERDES Input |
|------------------|--------------|
| PSCHAR_CKIO0 | TBCBx |
| PSCHAR_LDIO[9:0] | LDINBx[9:0] |

The x in the table will be a single channel in SERDES quad B, selected by the SCHAR_CHAN control bits. The decoding of SCHAR_CHAN is shown in Table 17.

Table 17. Decoding of SCHAR_CHAN

| SCHAR_CHAN0 | SCHAR_CHAN1 | Channel |
|-------------|-------------|---------|
| 0 | 0 | BA |
| 1 | 0 | BB |
| 0 | 1 | BC |
| 1 | 1 | BD |

The receive characterization test mode is entered when SCHAR_ENA=1 and SCHAR_TXSEL=0. In this mode, one of the channels of SERDES outputs is observed at chip ports as shown in Table 18. The channel that is observed is also based on the decoding of SCHAR_CHAN as shown in Table 18.

Table 18. SERDES Receive Characterization Mode

| SERDES Output | Chip Port |
|---------------|------------------|
| LDOUTBx[9:0] | PSCHAR_LDIO[9:0] |
| RBC0Bx | PSCHAR_CKIO0 |
| RBC1Bx | PSCHAR_CKIO1 |

Embedded Core Block RAM

There are two independent memory slices (labeled A and B) in the embedded core. Each memory slice has a capacity of 4K words by 36 bits. These are in addition to the block RAMs found in the FPGA portion of the ORSO42G5 and ORSO82G5. Although the memory slices are in the embedded core part of the chip, they do not interact with the rest of the embedded core circuits, but are standalone memories designed specifically to increase RAM capacity in the ORSO42G5 and ORSO82G5 chip. They can be used by the soft IP cores implemented in the FPGA portion of the FPSC.

A block diagram of a memory slice is shown in Figure 48. Each memory slice is organized into two sections (labeled SRAM A and SRAM B) and has one read port, one write port and four byte-write-enable (active-low) signals. Each byte has eight data bits and a control/parity bit. The control/parity bit responds to the same byte enable (BYTEWN_x[x]) as its corresponding data. No special logic such as parity checking is performed on this bit by the core. The read data from the memory is registered so that it works as a pipelined synchronous memory block. The minimum timing specifications are shown in Figure 49 and Figure 50. Signal names and functions are summarized later in Table 19 and follow the general Series 4 naming conventions.

Figure 48. Block Diagram, Embedded Core Memory Slice

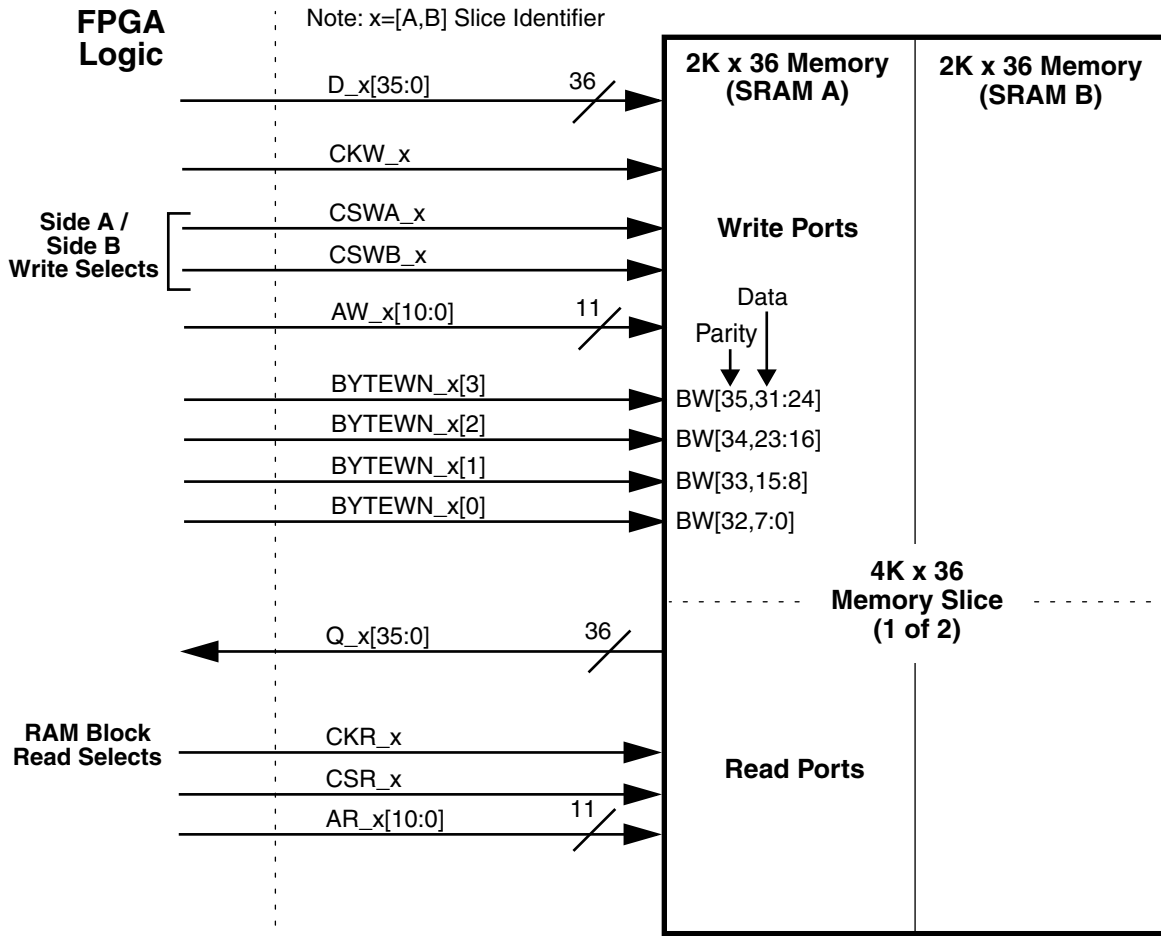

Figure 49. Minimum Timing Specs for Memory Blocks-Write Cycle (-1 Speed Grade)

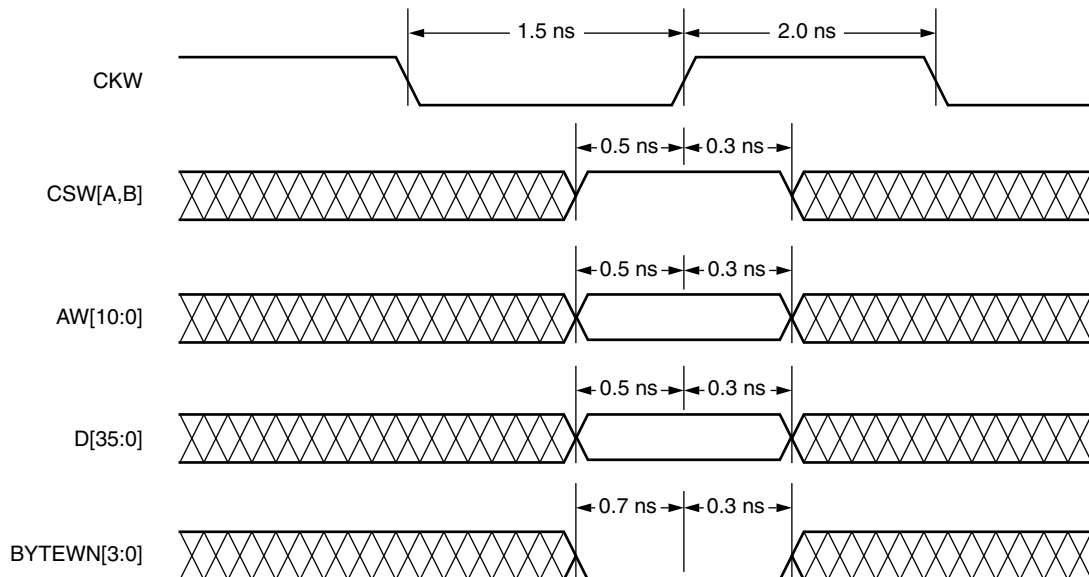

Figure 50. Minimum Timing Specs for Memory Blocks-Read Cycle (-1 Speed Grade)

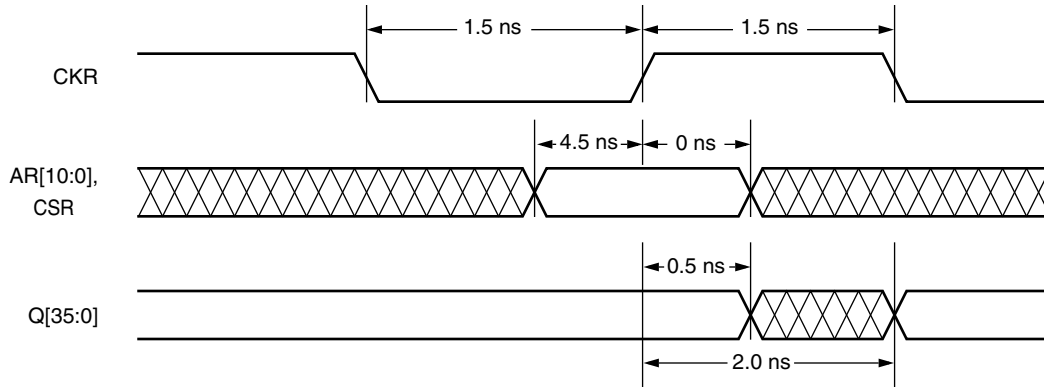

Table 19 summarizes the Embedded Memory Signals at the Core/FPGA interface. In the table, an input refers to a signal flowing into the embedded core and an output refers to a signal flowing out of the embedded core.

Table 19. Embedded Memory Core/FPGA Interface Signal Description

| FPGA/Embedded Core Interface Signal Name] | Input (I) to or Output (O) from Core | Signal Description |
|---|--------------------------------------|--|
| Memory Slice Interface Signals | | |
| D_[A:B][35:0] | I | Data in – memory slice [A:B] |
| CKW_[A:B] | I | Write clock – memory slice [A:B]. |
| CSWA_[A:B] | I | Write chip select for SRAM A – memory slice [A:B]. |
| CSWB_[A:B] | I | Write chip select for SRAM B – memory slice [A:B]. |
| AW_[A:B][10:0] | I | Write address – memory slice [A:B]. |
| BYTEWN_[A:B][3:0] | I | Write control pins for byte-at-a-time write-memory slice [A:B]. |
| Q_[A:B][35:0] | O | Data out – memory slice [A:B]. |
| CKR_[A:B] | I | Read clock – memory slice [A:B]. |
| CSR_[A:B] | I | Read chip select – memory slice [A:B]. CSR_[A:B]= 0 selects SRAM A. CSR_[A:B]= 1 selects SRAM B. |
| AR_[A:B][10:0] | I | Read address – memory slice [A:B]. |

Register Maps

The memory map for the ORSO42G5 and ORSO82G5 core is only part of the full memory map of the ORSO42G5 and ORSO82G5 devices. The ORSO42G5 and ORSO82G5 are ORCA Series 4 based devices and thus use the system bus as a communication bridge. The ORSO42G5 and ORSO82G5 core register map contained in this data sheet only covers the embedded ASIC core of the device, not the entire device. The system bus itself, and the generic FPGA memory map, are fully documented in the MPI/System Bus Application Note. As part of the system bus, the embedded ASIC core of an FPSC is located at address offset 0x30000. The ORSO42G5 and ORSO82G5 embedded core is an eight-bit slave interface on the Series 4 system bus. The ORSO42G5 and ORSO82G5 core registers are clocked by the system bus main clock.

Each ORCA device contains a device ID. This device ID is unique to each ORCA device and can be used for device identification and assist in the system debugging. The device ID is located at absolute address 0x0-0x3. The ORSO42G5 and ORCA82G5 device IDs are 0xDC012282. More information on the device ID and other Series 4 generic registers can be found in technical note TN1017, *ORCA Series 4 MPI/System Bus*.

If a clock is not provided to the reference clock, the registers will fail to operate.

The ORSO42G5 and ORSO82G5 core registers do not check for parity on a write operation. On a read operation, no parity is generated, and a “0” is passed back to the initiating bus master interface on the parity signal line.

Types of Registers

The registers in ORSO42G5 and ORSO82G5 are 8-bit memory locations which, in general, can be classified into several types:

General Core Status Registers

Read-only registers to convey the status information of various operations within the FPSC core. An example is the state of the LKI-xx receive PLL lock indicator outside the SERDES.

Alarm Status and Mask Registers

The alarm status registers are enabled or masked by the corresponding alarm enable registers. An example of such an alarm is the Out-Of-Frame (OOF) bit OOF_xx which is enabled by the corresponding alarm enable bit OOF_ENxx (xx indicates one of the SERDES channels). (The OOF and BIP error alarms are also available as signals across the core-FPGA boundary for each channel.) All the alarms for a given channel will be read into a single status bit (ALARM_STATUS_[AA-BD]). In addition, an event on any of these alarm status bits will generate an interrupt to the FPSC slave of the interrupt cause register on the system bus interface (see technical note TN1017). All alarm and status registers are clear on read.

Control Registers

Read-write registers to setup the control inputs that define the operation of the FPSC core. The SERDES block within the ORSO42G5 and ORSO82G5 core has a set of status and control registers for its operation. There is another group of status and control registers which are implemented outside the SERDES, which are related to the SERDES and other functional blocks in the FPSC core. They will be described in detail here.

Each SERDES has four independent channels, which are named A, B, C or D. Using this nomenclature, the SERDES A channels are named as AA, AB, AC and AD, while SERDES B channels will be BA, BB, BC and BD. The register address allocation for the ORSO82G5 is shown in Table 20. Detailed descriptions of all of the register bits are provided in Table 21 through Table 36.

Table 20. Memory Space Allocation in the FPSC Core

| Address (Hex) | Description |
|---------------|---|
| 3000x | Channel A in SERDES A block, internal registers (not available in the ORSO42G5) |
| 3001x | Channel B in SERDES A block, internal registers (not available in the ORSO42G5) |
| 3002x | Channel C in SERDES A block, internal registers |
| 3003x | Channel D in SERDES A block, internal registers |
| 3010x | Channel A in SERDES B block, internal registers (not available in the ORSO42G5) |
| 3011x | Channel B in SERDES B block, internal registers (not available in the ORSO42G5) |
| 3012x | Channel C in SERDES B block, internal registers |
| 3013x | Channel D in SERDES B block, internal registers |
| 3080x | Channel AA registers outside the SERDES (not available in the ORSO42G5) |
| 3081x | Channel AB registers outside the SERDES (not available in the ORSO42G5) |
| 3082x | Channel AC registers outside the SERDES |
| 3083x | Channel AD registers outside the SERDES |
| 3090x | Channel BA registers outside the SERDES (not available in the ORSO42G5) |
| 3091x | Channel BB registers outside the SERDES (not available in the ORSO42G5) |
| 3092x | Channel BC registers outside the SERDES |
| 3093x | Channel BD registers outside the SERDES |
| 30Axx | All Channels registers |

Register Reset Conditions

The reset conditions for the registers vary depending on register type. See the tables and the accompanying text for a description of the reset conditions.

Table 21. SERDES Alarm and Alarm Mask Register Descriptions – ORSO42G5

| (0x) Absolute Address | Bit | Name | Reset Value (0x) | Description | Mode |
|---|-------|---------|------------------------|--|------|
| SERDES Alarm Registers (Read Only) xx = [AC, AD, BC, BD] | | | | | |
| 30020 - AC 30030 - AD 30120 - BC 30130 - BD | [0] | RSVD | 00 | Reserved - May be non-zero | — |
| | [1] | LKI_xx | | Receive PLL Lock Indication, Channel xx. LKI_xx = 1 indicates the receive PLL is locked. Note that the PLL can either lock to the incoming data or to RECLK_[A:B]. If the PLL is locked to data and the data stream is terminated, LKI_xx will go low until the PLL locks to REFCLK_[A:B]. | Both |
| | [2:7] | RSVD | | Reserved - May be non-zero | — |
| SERDES Alarm Mask Registers (Read/Write) xx = [AC, AD, BC, BD] | | | | | |
| 30021 - AC 30031 - AD 30121 - BC 30131 - BD | [0] | RSVD | FF | Reserved | — |
| | [1] | MLKI_xx | | Mask Receive PLL Lock Indication, Channel MLKI_xx = 1 indicates LKI_xx is enabled | Both |
| | [2:7] | RSVD | | Reserved | — |

Table 22. SERDES Per-Channel Transmit Configuration Register Descriptions – ORSO42G5

| (0x) Absolute Address | Bit | Name | Reset Value (0x) | Description | Mode |
|---|------|-------------------------------|------------------|---|------|
| SERDES Transmit Per-Channel Configuration Registers (Read/Write) xx = [AC, AD, BC, BD] | | | | | |
| 30022 - AC 30032 - AD 30122 - BC 30132 - BD | [0] | TXHR _{xx} | 00 | Transmit Half Rate Selection Bit, Channel xx. When TXHR _{xx} = 1, HDOUT _{xx} 's baud rate = (REFCLK[A:B]*8) and TCK78[A:B] = (REFCLK[A:B]/4); when TXHR _{xx} =0, HDOUT _{xx} 's baud rate = (REFCLK[A:B]*16) and TCK78[A:B]=(REFCLK[A:B]/2). TXHR _{xx} = 0 on device reset. | Both |
| | [1] | PWRDNT _{xx} | | Transmit Powerdown Control Bit, Channel xx. When PWRDNT _{xx} = 1, sections of the transmit hardware are powered down. PWRDNT _{xx} = 0 on device reset. | Both |
| | [2] | PE0 _{xx} | | Transmit Preemphasis Selection Bit 0, Channel xx. PE0 _{xx} and PE1 _{xx} select one of three preemphasis settings for the transmit section. PE0 _{xx} =PE1 _{xx} = 0, Preemphasis is 0%; PE0 _{xx} =1, PE1 _{xx} = 0 or PE0 _{xx} =0, PE1 _{xx} = 1, Preemphasis is 12.5%; PE0 _{xx} =PE1 _{xx} = 1, Preemphasis is 25%. PE0 _{xx} =PE1 _{xx} = 0 on device reset. | Both |
| | [3] | PE1 _{xx} | | | Both |
| | [4] | HAMP _{xx} | | Transmit Half Amplitude Selection Bit, Channel xx. When HAMP _{xx} = 1, the transmit output buffer voltage swing is limited to half its normal amplitude. Otherwise, the transmit output buffer maintains its full voltage swing. HAMP _{xx} = 0 on device reset. | Both |
| [5:7] | RSVD | Reserved, Always set to "000" | — | | |

Table 23. SERDES Per-Channel Receive Configuration Register Descriptions – ORSO42G5

| (0x) Absolute Address | Bit | Name | Reset Value (0x) | Description | Mode |
|--|-------|----------------------|------------------|---|------|
| SERDES Receive Per-Channel Configuration Registers (Read/Write) xx = [AC, AD, BC, BD] | | | | | |
| 30023 - AC 30033 - AD 30122 - BC 30132 - BD | [0] | RXHR _{xx} | 20 | Receive Half Rate Selection Bit, Channel xx. When RXHR _{xx} = 1, HDIN _{xx} 's baud rate = (REFCLK[A:B]*8) and RCK78[A:B] = (REFCLK[A:B]/4); When RXHR _{xx} =0, HDIN _{xx} 's baud rate = (REFCLK[A:B]*16) and RCK78[A:B]=(REFCLK/2). RXHR _{xx} = 0 on device reset. | Both |
| | [1] | PWRDNR _{xx} | | Receiver Power Down Control Bit, Channel xx. When PWRDNR _{xx} = 1, sections of the receive hardware are powered down. PWRDNR _{xx} = 0 on device reset. | Both |
| | [2:7] | RSVD | | Reserved (Bit 2 = 1 on device reset) | — |

Table 24. SERDES Per Channel Configuration Registers (Read/Write) – ORSO42G5

| (0x) Absolute Address | Bit | Name | Reset Value (0x) | Description | Mode |
|---|-------|----------------------------------|------------------|--|--------------|
| SERDES Per Channel Transmit and Receive Channel Configuration Registers (Read/Write) xx = [AC, AD, BC, BD] | | | | | |
| 30024 - AC 30034 - AD 30124 - BC 30134 - BD | [0] | RSVD | 40 | Reserved | — |
| | [1] | MASK_xx | | Transmit and Receive Alarm Mask Bit, Channel xx. When MASK_xx = 1, the transmit and receive alarms of a channel are prevented from generating an alarm (i.e., they are masked or disabled). The MASK_xx bit overrides the individual alarm mask bits in the Alarm Mask Registers. MASK_xx = 1 on device reset. | Both |
| | [2] | SWRST_xx | | Transmit and Receive Software Reset Bit, Channel xx. When SWRST_xx = 1, this bit provides the same function as the hardware reset, except that all configuration register settings are unaltered. This is not a self-clearing bit. Once set, this bit must be manually set and cleared. SWRST = 0 on device reset. | Both |
| | [3:6] | RSVD | | Reserved | — |
| | [7] | TESTEN_xx | | Transmit and receive Test Enable Bit, Channel xx. When TESTEN_xx = 1, the transmit and receive sections of channel xx are place in test mode. The TESTMODE_xx bits (30006, 30106, etc.) must be set to specify the desired test. The GTESTEN_[A:B] bits override the individual TESTEN_xx settings. | Both |
| 30026-AC 30036-AD 30126-BC 30136-BD | [0] | TESTMODE_xx | 00 | SERDES Test Mode Select, channel xx. TESTMODE_xx = 0 selects Near End Loopback (CML TX to CML RX internally) TESTMODE_xx = 1 selects Far End Loopback (CML RX to CML TX internally) | Factory Test |
| [1:7] | RSVD | Reserved, Set to zero (default). | | — | |

Table 25. SERDES Per-Block Control Register Descriptions – ORSO42G5

| (0x) Absolute Address | Bit | Name | Reset Value (0x) | Description | Mode |
|---|-------|---------------|------------------|--|---------|
| SERDES Per-Block Control Register (Read/Write) xx = [AC, AD, BC, BD] | | | | | |
| 30005 - A 30105 - B | [0] | RSVD | 44 | Reserved | — |
| | [1] | GMASK_[A:B] | | Global Mask. When GMASK_[A:B] = 1, the transmit and receive alarms of all channel in the SERDES block are prevented from generating an alarm (i.e., they are masked or disabled). The GMASK_[A:B] bit overrides the individual MASK_xx bits. GMASK_[A:B] = 1 on device reset. | Both |
| | [2] | GSWRST_[A:B] | | Software reset bit. The GSWRST_[A:B] bit provides the same function as the hardware reset for the transmit and receive sections of all four channels, except that the device configuration settings are not affected when GSWRST_[A:B] is asserted. This is not a self-clearing bit. Once set, this bit must be manually set and cleared. The GSWRST_[A:B] bit overrides the individual SWRST_xx bits. GSWRST_[A:B] = 0 on device reset. | Both |
| | [3] | GPWRDNT_[A:B] | | Powerdown Transmit Function. When GPWRDNT_[A:B] = 1, sections of the transmit hardware for all four channels are powered down. The GPWRDNT_[A:B] bit overrides the individual PWRDNT_xx bits. GPWRDNT_[A:B] = 0 on device reset. | Both |
| | [4] | GPWRDNR_[A:B] | | Powerdown Receive Function. When GPWRDNR_[A:B] = 1, sections of the receive hardware for all four channels are powered down. The GPWRDNR_[A:B] bit overrides the individual PWRDNR_xx bits. GPWRDNR_[A:B] = 0 on device reset. | Both |
| | [5:6] | RSVD | | Reserved | — |
| | [7] | GTESTEN_[A:B] | | Global Test Enable Bit. When GTESTEN_[A:B] = 1, the transmit and receive sections of all channels in the block are place in test mode. The TESTMODE_xx bits (30026, 30126, etc.) must be set to specify the desired test on a per-channel basis. The GTESTEN_[A:B] bits override the individual TESTEN_xx settings. | Factory |

Table 26. Per-Channel Control Register Descriptions – ORSO42G5

| (0x) Absolute Address | Bit | Name | Reset Value (0x) | Description | Mode |
|--|-------|----------------------|--------------------------------|---|-------|
| Per-Channel Control Register (Read/Write) xx = AC, AD, BC, BD | | | | | |
| 30820 - AC 30830 - AD | [0:4] | RSVD | 00 | Reserved | — |
| | [5] | CELL_ALIGN_ERR_EN_xx | | '1' = Alarm enabled for CELL_ALIGN_ERR_xx | Cell |
| 30920 - BC | [6] | TX_URUN_ERR_EN_xx | | '1' = Alarm enabled for TX_URUN_ERR_xx | Cell |
| 30930 - BD | [7] | TX_ORUN_ERR_EN_xx | | '1' = Alarm enabled for TX_ORUN_ERR_xx | Cell |
| 30821 - AC 30831 - AD 30921 - BC 30931 - BD | [0] | RSVD | 00 | Reserved | — |
| | [1] | OOF_EN_xx | | '1' = Alarm enabled for OOF_xx | Both |
| | [2] | EX_SEQ_ERR_EN_xx | | '1' = Alarm enabled for EX_SEQ_ERR_xx | Cell |
| | [3] | SEQ_ERR_EN_xx | | '1' = Alarm enabled for SEQ_ERR_xx | Cell |
| | [4] | CELL_BIP_ERR_EN_xx | | '1' = Alarm enabled for CELL_BIP_ERR_xx | Cell |
| | [5] | B1_ERR_EN_xx | | '1' = Alarm enabled for B1_ERR_xx | Both |
| | [6] | RX_FIFO_OVRUN_EN_xx | | '1' = Alarm enabled for RX_FIFO_OVRUN_xx | Cell |
| | [7] | RDI_EN_xx | '1' = Alarm enabled for RDI_xx | Both | |
| 30822 - AC 30832 - AD 30922 - BC 30932 - BD | [0] | ENABLE_JUST_xx | 00 | ENABLE_JUST_xx = 1 causes the core to interpret pointer bytes for positive or negative justification | SONET |
| | [1] | FMPU_STR_EN_xx | | FMPU_STR_EN_xx = 1 enables a channel for alignment within a multi-channel alignment group | SONET |
| | [2:3] | FMPU_SYNMODE_xx | | "00" - No channel alignment "01" - Twin channel alignment "10" - 4 channel alignment "11" - By-8 alignment | SONET |
| | [4] | DSCR_INH_xx | | Descrambling Inhibit, DSCR_INH = 1 inhibits descrambling (in the Rx direction) and scrambling (in the Tx direction). When inhibiting the scrambler and descrambler the AUTO_B1_xx calculated and checked B1 value will always be incorrect. | Both |
| | [5] | FFRM_EN_xx | | Fast Frame Enable, FFRM_EN=1 enables the fast frame mode. | Both |
| | [6] | AIS_ON_xx | | Alarm Indication Signal (control), AIS_ON = 1 forces AIS-L insertion. | Both |
| | [7] | AIS_ON_OOF_xx | | Alarm Indication Signal on Out of Frame, AIS_ON_OOF = 1 forces AIS-L insertion during OOF = 1. | Both |

Table 26. Per-Channel Control Register Descriptions – ORSO42G5 (Continued)

| (0x) Absolute Address | Bit | Name | Reset Value (0x) | Description | Mode |
|--|-----|---------------------|------------------|---|-------------|
| 30823 - AC 30833 - AD 30923 - BC 30933 - BD | [0] | BYPASS_ALGN_FIFO_xx | 00 | Bypass alignment FIFO =1 in RX path in SONET mode. DOUT_xx data is clocked off RWCKxx. | SONET |
| | [1] | SERDES_ONLY_MODE_xx | | SERDES-Only Mode. SERDES_ONLY_MODE =1 bypasses all the SONET and cell functions. Data is sent directly from the SERDES to the FPGA logic in the RX path and is passed directly from the FPGA logic to the SERDES in the TX path. | SERDES Only |
| | [2] | FORCE_B1_ERR_xx | | Force B1 Error. FORCE_B1_ERR =1 forces a Section B1 error (Bit Interleaved Parity Error) in the TX path. Valid only when the corresponding AUTO_TOH_xx bit or AUTO_B1_xx bit is set to one. | Both |
| | [3] | FORCE_BIP8_ERR_xx | | Force BIP8 Error, FORCE_BIP8_ERR =1 forces cell BIP8 error in the TX path. | Cell |
| | [4] | FORCE_A1A2_ERR_xx | | Force A1A2 Error, FORCE_A1A2_ERR =1 forces an error in A1A2 bytes (framing error) in the TX path. Valid only when the corresponding AUTO_TOH_xx bit or AUTO_A1A2_xx bit is set to one. | Both |
| | [5] | FORCE_EX_SEQ_ERR_xx | | Force Excessive Sequence Errors. FORCE_EXP_SEQ_ERR_xx = 1 forces sequence errors in the TX path by inverting the link header byte sequence number. | Cell |
| | [6] | FORCE_SEQ_ERR_xx | | Force Sequence Error, FORCE_SEQ_ERR =1 forces one sequence error in the TX path. After this bit is set, the next Link Header byte's sequence number is inverted. The Link Header after the errored Link Header byte will have the correct sequence number | Cell |
| | [7] | FORCE_RDI_xx | | Force Remote Defect Indication, FORCE_RDI =1 forces RDI errors in the TX path. The K2 byte in TOH is set to "00000110. Valid only when AUTO_TOH_xx bit is set to 1. | Cell |

Table 26. Per-Channel Control Register Descriptions – ORSO42G5 (Continued)

| (0x) Absolute Address | Bit | Name | Reset Value (0x) | Description | Mode |
|--|-------|-----------------|---|---|-------|
| 30824 - AC 30834 - AD 30924 - BC 30934 - BD | [0] | LCKREFN_xx | 00 | 0 = Lock receiver to reference clock (REFCLK) 1 = Lock receiver to HDINxx data | Both |
| | [1] | LOOPENB_xx | | LOOPENB_xx =1 Enable high-speed internal loopback from TX to RX. Disable the HDOUT buffers. | Both |
| | [2] | DISABLE_TX_xx | | Disable Transmitter, For DISABLE_TX = 1 the TX Link is disabled. The disabled link is ignored by the Output Port Controller (OPC) and internally generated idle cells are transmitted on the link. If the link is disabled during the transmission of a cell on the link, the entire cell is transmitted before the link is declared invalid. | Cell |
| | [3] | DISABLE_RX_xx | | Disable Receiver, DISABLE_RX = 1 disables the RX link for cell processing by the Input Port Controller (IPC). The IPC will not read cells from a link if this bit is set for that link | Cell |
| | [4] | CELL_BIP_INH_xx | | Cell BIP (Check) Inhibit, CELL_BIP_INH = 1 prevents cells from being dropped due to a Cell BIP error, in the RX path. If this bit is not set, then cells will be dropped automatically if a cell bip error is detected by the core. The CELLDROP signal across the core-FPGA interface will be active only if this bit is NOT set. | Cell |
| | [5] | CELL_SEQ_INH_xx | | Cell Sequence (Checking) Inhibit, CELL_SEQ_INH = 1 prevents cells in the RX path from being dropped due to a sequence error. If this bit is not set, then cells will be dropped automatically if a sequence error is detected internally. The CELLDROP signal across the core-FPGA interface will be active only if this bit is NOT set. | Cell |
| | [6] | AUTO_TOH_xx | | Automatic TOH Generation, AUTO_TOH_xx =1 enables the TX core to automatically generate TOH bytes. All the FORCE_* register bits are valid if this bit is set. This bit should be set to 1 in Cell Mode. It can be set to 1 or 0 in SONET Mode. If this bit is not set, then user has to provide all the TOH bytes or use the AUTO_SOH mode. | SONET |
| | [7] | FMPU_RESYNC1_xx | Single channel alignment FIFO reset. Rising edge sensitive. Write a 0 and then a 1 to enable this bit. When enabled, the read pointer in the alignment FIFO is reset to the middle of the FIFO. This bit is valid only when FMPU_SYNMODE_xx = 00 (no multi channel alignment) | SONET | |
| 30825 - AC 30835 - AD 30925 - BC 30935 - BD | [0:7] | LINK_NUM_TX_xx | 00 | Transmit Link Number, This value is transmitted in the "F1" byte of the TOH. This value is used to verify that the links are connected properly and is only used in the AUTO_TOH mode. | Both |

Table 26. Per-Channel Control Register Descriptions – ORSO42G5 (Continued)

| (0x) Absolute Address | Bit | Name | Reset Value (0x) | Description | Mode |
|--|-------|--------------|------------------------|--|------|
| 30826 - AC 30836 - AD 30926 - BC 30936 - BD | [0:5] | RSVD | 00 | Reserved | — |
| | [6] | AUTO_B1_xx | | AUTO_B1_xx = 0, B1 is not inserted by the embedded core AUTO_B1_xx = 1, B1 is calculated and inserted by the embedded core AUTO_TOH_xx = 1 overrides this bit | Both |
| | [7] | AUTO_A1A2_xx | | AUTO_A1A2_xx = 0, A1/A2 bytes are not inserted by the embedded core AUTO_A1A2_xx = 1, A1/A2 bytes inserted by the embedded core AUTO_TOH_xx = 1 overrides this bit | |

Table 27. Per-Channel Status Register Descriptions – ORSO42G5

| (0x) Absolute Address | Bit | Name | Reset Value (0x) | Description | Mode |
|---|-------|-------------------|------------------------|---|------|
| Channel Status Registers (Read Only) xx = [AC, AD, BC, BD] | | | | | |
| 30828 - AC 30838 - AD 30928 - BC 30938 - BD | [0:4] | RSVD | 00 | Reserved | — |
| | [5] | CELL_ALIGN_ERR_xx | | Cell Alignment Error, CELL_ALIGN_ERR = 1 indicates that the internal transmit frame processor did not detect a start of cell indicator when it was expecting a new cell. If the corresponding alarm enable bit has been set, a 1 on this bit will cause an alarm. | Cell |
| | [6] | TX_URUN_ERR_xx | | Transmit Underrun Error, TX_URUN_ERR = 1 indicates an underrun error in the transmit Asynchronous FIFO. If the corresponding alarm enable bit has been set, a 1 on this bit will cause an alarm. | Cell |
| | [7] | TX_ORUN_ERR_xx | | Transmit Overrun Error, TX_ORUN_ERR = 1 indicates an overrun error in the transmit Asynchronous FIFO. The TX FIFO is designed to not overflow since it sends backpressure signal to the FPGA when it cannot accept more cells. If the corresponding alarm enable bit has been set, a 1 on this bit will cause an alarm. | Cell |
| 30829 - AC 30839 - AD 30929 - BC 30939 - BD | [0] | RSVD | 00 | Reserved | — |
| | [1] | OOF_xx | | OOF_xx = 1 indicates OOF has been detected in this link. If the corresponding alarm enable bit has been set, a 1 on this bit will cause an alarm | Both |
| | [2] | EX_SEQ_ERR_xx | | Excessive Sequence Errors, EX_SEQ_ERR = 1 indicates that three consecutive cells containing sequence errors have been detected in this link. If the corresponding alarm enable bit has been set, a 1 on this bit will cause an alarm. | Cell |
| | [3] | SEQ_ERR_xx | | Sequence Error, SEQ_ERR = 1 indicates that a sequence error has been detected for a cell on this link. If the corresponding alarm enable bit has been set, a 1 on this bit will cause an alarm. | Cell |
| | [4] | CELL_BIP_ERR_xx | | Cell mode BIP Error, CELL_BIP_ERR = 1 indicates that a BIP error has been detected in a cell on the link. If the corresponding alarm enable bit has been set, a 1 on this bit will cause an alarm. | Cell |
| | [5] | B1_ERR_xx | | Bit Interleaved Parity Error, B1_ERR = 1 indicates that a Section B1 error has been detected on the link. If the corresponding alarm enable bit has been set, a 1 on this bit will cause an alarm. | Both |
| | [6] | RX_FIFO_OVRUN_xx | | Receive FIFO Overrun, RX_FIFO_OVRUN_xx = 1 indicates that the asynchronous RX FIFO has detected an overrun condition. If the corresponding alarm enable bit has been set, a 1 on this bit will cause an alarm. | Cell |
| | [7] | RDI_xx | | Remote Defect Indication, RDI = 1 indicates that a RDI has been detected on the link. If the corresponding alarm enable bit has been set, a 1 on this bit will cause an alarm | Both |

Table 27. Per-Channel Status Register Descriptions – ORSO42G5 (Continued)

| (0x) Absolute Address | Bit | Name | Reset Value (0x) | Description | Mode |
|--|-------|------------------------|------------------------|---|-------|
| 3082A - AC 3083A - AD 3092A - BC 3093A - BD | [0:4] | RSVD | 00 | Reserved | — |
| | [5] | STAT_CELL_ALIGN_ERR_xx | | STAT_CELL_ALIGN_ERR_xx = 1 same as CELL_ALIGN_ERR_xx except that a 1 on this bit can NOT cause an interrupt | Cell |
| | [6] | STAT_TX_URUN_ERR_xx | | STAT_TX_URUN_ERR_xx = 1 same as TX_URUN_ERR_xx except that a 1 on this bit can NOT cause an interrupt | Cell |
| | [7] | STAT_TX_ORUN_ERR_xx | | STAT_TX_ORUN_ERR_xx = 1 same as TX_ORUN_ERR_xx except that a 1 on this bit can NOT cause an interrupt | Cell |
| 3082B - AC 3083B - AD 3092B - BC 3093B - BD | [0] | RSVD | 00 | Reserved | — |
| | [1] | STAT_OOF_xx | | STAT_OOF_xx = 1 same as OOF_xx except that a 1 on this bit can NOT cause an interrupt | Both |
| | [2] | STAT_EX_SEQ_ERR_xx | | STAT_EX_SEQ_ERR_xx = 1 same as EX_SEQ_ERR_xx except that a 1 on this bit can NOT cause an interrupt | Cell |
| | [3] | STAT_SEQ_ERR_xx | | STAT_SEQ_ERR_xx = 1 same as SEQ_ERR_xx except that a 1 on this bit can NOT cause an interrupt | Cell |
| | [4] | STAT_CELL_BIP_ERR_xx | | STAT_CELL_BIP_ERR_xx = 1 same as CELL_BIP_ERR_xx except that a 1 on this bit can NOT cause an interrupt | Cell |
| | [5] | STAT_B1_ERR_xx | | STAT_B1_ERR_xx = 1 same as B1_ERR_xx except that a 1 on this bit can NOT cause an interrupt | Both |
| | [6] | STAT_RX_FIFO_OVRUN_xx | | STAT_RX_FIFO_OVRUN_xx = 1 same as RX_FIFO_OVRUN_xx except that a 1 on this bit can NOT cause an interrupt | Cell |
| | [7] | STAT_RDI_xx | | STAT_RDI_xx = 1 same as RDI_xx except that a 1 on this bit can NOT cause an interrupt | Both |
| 3082C - AC 3083C - AD 3092C - BC 3093C - BD | [0:7] | LINK_NUM_RX_xx | 00 | Link number received that is stored in the F1 byte position of the SONET TOH | Both |
| 3082E - AC 3083E AD 3092E - BC 3093E - BD | [0:5] | RSVD | 00 | Reserved | — |
| | [6] | CH248_SYNC_xx | | CH248_SYNC_xx = 1 indicates that A1A2 bytes have been detected by link xx for multi-channel alignment | SONET |
| | [7] | RX_LINK_GOOD_xx | | RX_LINK_GOOD_xx = 1 indicates that frame has been acquired and the link has been stable. Goes high at an A1A2 boundary but can go low at any point in a frame due to excessive errors | Cell |

Table 28. Common Control Register Descriptions – ORSO42G5

| (0x) Absolute Address | Bit | Name | Reset Value (0x) | Description | Mode |
|-----------------------|-------|-------------------|------------------|--|-------|
| 30A00 | [0:1] | RCKSELB | 00 | “10” - Channel BC source for clock RCK78B “11” - Channel BD source for clock RCK78B | Both |
| | [2:3] | TCKSELB | | “10” - Channel BC source for clock TCK78B “11” - Channel BD source for clock TCK78B | Both |
| | [4:5] | RCKSELA | | “10” - Channel AC source for clock RCK78A “11” - Channel AD source for clock RCK78A | Both |
| | [6:7] | TCKSELA | | “10” - Channel AC source for clock TCK78A “11” - Channel AD source for clock TCK78A | Both |
| 30A01 | [0:2] | CELL_SIZE | 00 | Cell Size, Three bits to set cell size. “000” - Cell size is 75 bytes, “001” - Cell size is 79 bytes, “010” - Cell size is 83 bytes, “011” - Cell size is 91 bytes These are the only supported cell sizes. | Cell |
| | [3:7] | RX_FIFO_MIN | | Set Minimum threshold value for alignment FIFO in SONET mode. When the read address for the FIFO is below this value at the time when write address is zero, it indicates that the FIFO is near overflow. This event will go high only once during a frame when a framing byte has been detected by the aligner. The default threshold value is “00000”. | SONET |
| 30A02 | 0 | TX_DISABLE_ON_RDI | 00 | Transmitter Disable on RDI (Detection), If TX_DISABLE_ON_RDI = 1 - No cell data is transmitted on a link in which a RDI has been detected by the corresponding link’s receiver. If this bit is set to 0, cell data will be transmitted on a link irrespective of detection of a RDI. | Cell |
| | [1:7] | RSVD | | Reserved | — |

Table 28. Common Control Register Descriptions – ORSO42G5 (Continued)

| (0x) Absolute Address | Bit | Name | Reset Value (0x) | Description | Mode |
|-----------------------|-------|-----------------|------------------|--|-------|
| 30A03 | [0] | NO_TX_RDI_EXSEQ | 00 | Not Transmission of RDI, If NO_TX_RDI_EXSEQ = 1, a transmit link will not send data if its corresponding receive link is not good due to excessive sequence errors. If this bit is set to 0, a transmit link will still send data even if its corresponding receive link has excessive sequence errors. This bit should always be set during simulation and in SONET mode. | Both |
| | [1] | AUTO_BUNDLE | | Automatic (Link) Bundle, AUTO_BUNDLE = 1 allows a link within a link group to remain active even when another link within that group is defective. Cell data from all links within that group will continue to be sent to the FPGA. If this bit is set to 0, then all links within a link group must be good before cell data are read from the links by the IPC and passed to the FPGA. | Cell |
| | [2] | RSVD | | Reserved | — |
| | [3] | REJOIN_A | | Link Rejoin, REJOIN = 1 forces any link in a SERDES block to reassert a “RX link good” signal automatically when three consecutive sequence numbers are correct on that link. | Cell |
| | [4] | AUTO_REMOVE_A | | Automatic (Link) Remove, AUTO_REMOVE = 1 indicates that any link in a SERDES block which sees three excessive sequence errors should deassert the “RX link good” signal which will cause the link to be inactive. | Cell |
| | [5] | RSVD | | Reserved | |
| | [6] | REJOIN_B | | Link Rejoin, REJOIN = 1 forces any link in a SERDES block to reassert a “RX link good” signal automatically when three consecutive sequence numbers are correct on that link. | Cell |
| | [7] | AUTO_REMOVE_B | | AUTO_REMOVE_B = 1 indicates that any link in SERDES block B which sees three excessive sequence errors should deassert the “RX link good” signal which will cause the link to be inactive. | Cell |
| 30A04 | [0:1] | RSVD | 00 | Reserved | — |
| | [2] | FMPU_RESYNC2_B2 | | Control to resync channels BC and BD which have been configured for multi channel alignment in SONET mode in block B. Requires a rising edge on this bit. Write a 0 followed by a 1. | SONET |
| | [3:4] | RSVD | | Reserve | SONET |
| | [5] | FMPU_RESYNC2_A2 | | Control to resync channels AC and AD which have been configured for multi channel alignment in SONET mode in block A. Requires a rising edge on this bit. Write a 0 followed by a 1. | SONET |
| | [6] | RSVD | | Reserved | SONET |
| | [7] | FMPU_RESYNC4 | | Control to resync all four channels which have been configured for multi channel alignment. | SONET |

Table 28. Common Control Register Descriptions – ORSO42G5 (Continued)

| (0x) Absolute Address | Bit | Name | Reset Value (0x) | Description | Mode |
|-----------------------|-------|-----------------|------------------|--|------|
| 30A05 | [0:2] | ERRCNT_CH | 00 | Error Count Channel Select, Control bits to select which channel's Section B1 error and Cell BIP error counts are recorded by the BIP_ERR_CNT and CELL_BIP_ERR_CNT registers. "010" - Channel AC, "011" - Channel AD, "110" - Channel BC, "111" - Channel BD | Both |
| | [3] | RSVD | | Reserved | — |
| | [4] | CELL_MODE_A2 | | Cell Mode Enable, CELL_MODE_A2 = 1 enables cell mode for the channel group AC and AD. | Cell |
| | [5] | RSVD | | Reserved | — |
| | [6] | CELL_MODE_B2 | | Cell Mode Enable, CELL_MODE_B2 = 1 enables cell mode for the channel group BC and BD. | Cell |
| | [7] | RSVD | | Reserved | — |
| 30A06 | [0:4] | RSVD | 00 | Reserved | — |
| | [5:6] | RESET_PHASE | | Reset Phase, Two bits to select delay phase for delaying the soft reset bit SOFT_RESET with respect to the synchronizing clock. Four delay phases can be selected through the values "00", "01", "10" and "11". | Both |
| | [7] | SOFT_RESET | | Soft Reset, SOFT_RESET=1 resets the embedded core flip flops except for the software registers. This bit does not affect the state of the registers inside the SERDES blocks. | Both |
| 30A07 | [0:6] | RSVD | 00 | Reserved | — |
| | [7] | TX_CFG_DONE | | Transmitter Configuration Done, Edge sensitive bit to indicate that all TX configuration bits are set. After all register bits have been set for Transmit direction, write a 0 and then a 1 to this bit. | Cell |
| 30A08 | [0] | ALARM_STATUS_BD | 00 | Alarm Status Indicator, This bit is an OR of all alarm status bits for the channel BD. A 1 on this bit will also set the alarm pin on the system bus interrupt cause register (on the FPGA side). | Both |
| | [1] | ALARM_STATUS_BC | | Alarm Status Indicator, This bit is an OR of all alarm status bits for the channel BC. A 1 on this bit will also set the alarm pin on the system bus interrupt cause register (on the FPGA side). | Both |
| | [2:3] | RSVD | | Reserved | — |
| | [4] | ALARM_STATUS_AD | | Alarm Status Indicator, This bit is an OR of all alarm status bits for the channel AD. A 1 on this bit will also set the alarm pin on the system bus interrupt cause register (on the FPGA side). | Both |
| | [5] | ALARM_STATUS_AC | | Alarm Status Indicator, This bit is an OR of all alarm status bits for the channel AC. A 1 on this bit will also set the alarm pin on the system bus interrupt cause register (on the FPGA side). | Both |
| | [6:7] | RSVD | | Reserved | — |

Table 28. Common Control Register Descriptions – ORSO42G5 (Continued)

| (0x) Absolute Address | Bit | Name | Reset Value (0x) | Description | Mode |
|-----------------------|-------|------------------|------------------|--|-------|
| 30A09 | [0:7] | B1_ERR_CNT | 00 | Error counter that increments when a section B1 error is detected on a link. The link is selected using ERRCNT_CHSEL. This counter is cleared on read. | Both |
| 30A0A | [0:7] | CELL_BIP_ERR_CNT | 00 | Cell BIP Error Counter, Error counter that increments when a Cell BIP error is detected on a link. The link being monitored is selected using ERRCNT_CHSEL. This counter is cleared on read. | Cell |
| 30A0B | [0:2] | RSVD | 00 | Reserved | |
| | [3] | CELL_DRP_B2 | | Cell Drop, CELL_DRP_B2 = 1 indicates that a cell has been dropped from the link group BC and BD | Cell |
| | [4] | RSVD | | Reserved | — |
| | [5] | CELL_DRP_A2 | | Cell Drop, CELL_DRP_A2 = 1 indicates that a cell has been dropped from the link group AC and AD | Cell |
| | [6:7] | RSVD | | Reserved | — |
| 30A0C | [0:1] | RSVD | 00 | Reserved | |
| | [2] | SYNC2_B2_OOS | | SYNC2_B2_OOS = 1 indicates that channels cannot be aligned within the links BC and BD in SONET mode | SONET |
| | [3:4] | RSVD | | Reserved | — |
| | [5] | SYNC2_A2_OOS | | SYNC2_A2_OOS = 1 indicates that channels cannot be aligned within the AC and AD links in SONET mode | SONET |
| | [6:7] | SYNC2_A1_OOS | | Reserved | — |
| 30A0D | [0:1] | RSVD | 00 | Reserved | — |
| | [2] | SYNC2_B2_OVFL | | SYNC2_B2_OVFL = 1 indicates that the alignment FIFO(s) in the links BC and BD are near overflow (i.e., at the time of writing into address 0, the read address was less than RX_FIFO_MIN) | SONET |
| | [3:4] | RSVD | | Reserved | — |
| | [5] | SYNC2_A2_OVFL | | SYNC2_A2_OVFL = 1 indicates that the alignment FIFO(s) in the links AC and AD are near overflow (i.e., at the time of writing into address 0, the read address was less than RX_FIFO_MIN) | SONET |
| | [6:7] | RSVD | | Reserved | — |
| 30A0E | [0:2] | RSVD | 00 | Reserved | |
| | [3] | BDL_ALIGN_ERR_B2 | | Alignment Error, BDL_ALIGN_ERR = 1 indicates that an alignment error has occurred in the link group pairs BC and BD | Cell |
| | [4] | RSVD | | Reserved | — |
| | [5] | BDL_ALIGN_ERR_A2 | | Alignment Error, BDL_ALIGN_ERR = 1 indicates that an alignment error has occurred in the link group pairs AC and AD | Cell |
| | [6:7] | RSVD | | Reserved | — |

Table 29. SERDES Alarm and Alarm Mask Register Descriptions – ORSO82G5

| (0x) Absolute Address | Bit | Name | Reset Value (0x) | Description | Mode |
|---|-------|---------|------------------|--|------|
| SERDES Alarm Registers (Read Only) xx = [AA,....,BD] | | | | | |
| 30000 - AA | [0] | RSVD | 00 | Reserved - May be non-zero | — |
| 30010 - AB 30020 - AC 30030 - AD | [1] | LKI_xx | | Receive PLL Lock Indication, Channel xx. LKI_xx = 1 indicates the receive PLL is locked. Note that the PLL can either lock to the incoming data or to RECLK_[A:B]. If the PLL is locked to data and the data stream is terminated, LKI_xx will go low until the PLL locks to REFCLK_[A:B]. | Both |
| 30100 - BA 30110 - BB 30120 - BC 30130 - BD | [2:7] | RSVD | | Reserved - May be non-zero | — |
| SERDES Alarm Mask Registers (Read/Write) xx = [AA,....,BD] | | | | | |
| 30001 - AA | [0] | RSVD | FF | Reserved | — |
| 30011 - AB 30021 - AC 30031 - AD | [1] | MLKI_xx | | Mask Receive PLL Lock Indication, Channel MLKI_xx = 1 indicates LKI_xx is enabled | Both |
| 30101 - BA 30111 - BB 30121 - BC 30131 - BD | [2:7] | RSVD | | Reserved | — |

Table 30. SERDES Per-Channel Transmit Configuration Register Descriptions – ORSO82G5

| (0x) Absolute Address | Bit | Name | Reset Value (0x) | Description | Mode |
|--|-------|-----------|------------------|---|---|
| SERDES Transmit Per-Channel Configuration Registers (Read/Write) xx = [AA,....,BD] | | | | | |
| 30002 - AA 30012 - AB 30022 - AC 30032 - AD 30102 - BA 30112 - BB 30122 - BC 30132 - BD | [0] | TXHR_xx | 00 | Transmit Half Rate Selection Bit, Channel xx. When TXHR_xx = 1, HDOUT_xx's baud rate = (REFCLK[A:B]*8) and TCK78[A:B] = (REFCLK[A:B]/4); when TXHR_xx=0, HDOUT_xx's baud rate = (REFCLK[A:B]*16) and TCK78[A:B] = (REFCLK[A:B]/2). TXHR_xx = 0 on device reset. | Both |
| | [1] | PWRDNT_xx | | Transmit Powerdown Control Bit, Channel xx. When PWRDNT_xx = 1, sections of the transmit hardware are powered down. PWRDNT_xx = 0 on device reset. | Both |
| | [2] | PE0_xx | | Transmit Preemphasis Selection Bit 0, Channel xx. PE0_xx and PE1_xx select one of three preemphasis settings for the transmit section. PE0_xx=PE1_xx = 0, Preemphasis is 0% PE0_xx=1, PE1_xx = 0 or PE0_xx=0, PE1_xx = 1, Preemphasis is 12.5% PE0_xx=PE1_xx = 1, Preemphasis is 25%. PE0_xx=PE1_xx = 0 on device reset. | Both |
| | [3] | PE1_xx | | | Both |
| | [4] | HAMP_xx | | | Transmit Half Amplitude Selection Bit, Channel xx. When HAMP_xx = 1, the transmit output buffer voltage swing is limited to half its normal amplitude. Otherwise, the transmit output buffer maintains its full voltage swing. HAMP_xx = 0 on device reset. |
| | [5:7] | RSVD | | Reserved, Always set to "000" | — |

Table 31. SERDES Per-Channel Receive Configuration Register Descriptions – ORSO82G5

| (0x) Absolute Address | Bit | Name | Reset Value (0x) | Description | Mode |
|---|-------|-----------|------------------|---|------|
| SERDES Receive Per-Channel Configuration Registers (Read/Write) xx = [AA, ..., BD] | | | | | |
| 30003 - AA 30013 - AB 30023 - AC 30033 - AD | [0] | RXHR_xx | 20 | Receive Half Rate Selection Bit, Channel xx. When RXHR_xx = 1, HDIN_xx's baud rate = (REFCLK[A:B]*8) and RCK78[A:B]=(REFCLK[A:B]/4); When RXHR_xx=0, HDIN_xx's baud rate = (REFCLK[A:B]*16) and RCK78[A:B]=(REFCLK/2). RXHR_xx = 0 on device reset. | Both |
| 30103 - BA 30113 - BB 30123 - BC 30133 - BD | [1] | PWRDNR_xx | | Receiver Power Down Control Bit, Channel xx. When PWRDNR_xx = 1, sections of the receive hardware are powered down. PWRDNR_xx = 0 on device reset. | Both |
| | [2:7] | RSVD | | Reserved (Bit 2 = 1 on device reset) | — |

Table 32. SERDES Common Configuration Register Descriptions – ORSO82G5

| (0x) Absolute Address | Bit | Name | Reset Value (0x) | Description | Mode |
|--|-------|-------------|------------------|--|--------------|
| SERDES Common Transmit and Receive Channel Configuration Registers (Read/Write) xx = [AA, ..., BD] | | | | | |
| 30004 - AA 30014 - AB 30024 - AC 30034 - AD 30104 - BA 30114 - BB 30124 - BC 30134 - BD | [0] | RSVD | 40 | Reserved | — |
| | [1] | MASK_xx | | Transmit and Receive Alarm Mask Bit, Channel xx. When MASK_xx = 1, the transmit and receive alarms of a channel are prevented from generating an alarm (i.e., they are masked or disabled). The MASK_xx bit overrides the individual alarm mask bits in the Alarm Mask Registers. MASK_xx = 1 on device reset. | Both |
| | [2] | SWRST_xx | | Transmit and Receive Software Reset Bit, Channel xx. When SWRST_xx = 1, this bit provides the same function as the hardware reset, except that all configuration register settings are unaltered. This is not a self-clearing bit. Once set, this bit must be manually set and cleared. SWRST = 0 on device reset. | Both |
| | [3:6] | RSVD | | Reserved | — |
| | [7] | TESTEN_xx | | Transmit and receive Test Enable Bit, Channel xx. When TESTEN_xx = 1, the transmit and receive sections of channel xx are place in test mode. The TESTMODE_xx bits (30006, 30106, etc.) must be set to specify the desired test. The GTESTEN_[A:B] bits override the individual TESTEN_xx settings. | Both |
| 30006-AA 30016-AB 30026-AC 30036-AD | [0] | TESTMODE_xx | 00 | SERDES Test Mode Select, channel xx. TESTMODE_xx = 0 selects Far End Loopback (CML TX to CML RX internally) TESTMODE_xx = 1 selects Near End Loopback (CML RX to CML TX internally) | Factory Test |
| 30106-BA 30116-BB 30126-BC 30136-BD | [1:7] | RSVD | | Reserved, Set to zero (default). | — |

Table 33. SERDES Per-Block Control Register Descriptions – ORSO82G5

| (0x) Absolute Address | Bit | Name | Reset Value (0x) | Description | Mode |
|--|-------|---------------|------------------|--|---------|
| SERDES Per-Block Control Register (Read/Write) xx = [AA, ..., BD] | | | | | |
| 30005 - A 30105 - B | [0] | RSVD | 44 | Reserved | — |
| | [1] | GMASK_[A:B] | | Global Mask. When GMASK_[A:B] = 1, the transmit and receive alarms of all channel in the SERDES block are prevented from generating an alarm (i.e., they are masked or disabled). The GMASK_[A:B] bit overrides the individual MASK_xx bits. GMASK_[A:B] = 1 on device reset. | Both |
| | [2] | GSWRST_[A:B] | | Software reset bit. The GSWRST_[A:B] bit provides the same function as the hardware reset for the transmit and receive sections of all four channels, except that the device configuration settings are not affected when GSWRST_[A:B] is asserted. This is not a self-clearing bit. Once set, this bit must be manually set and cleared. The GSWRST_[A:B] bit overrides the individual SWRST_xx bits. GSWRST_[A:B] = 0 on device reset. | Both |
| | [3] | GPWRDNT_[A:B] | | Powerdown Transmit Function. When GPWRDNT_[A:B] = 1, sections of the transmit hardware for all four channels are powered down. The GPWRDNT_[A:B] bit overrides the individual PWRDNT_xx bits. GPWRDNT_[A:B] = 0 on device reset. | Both |
| | [4] | GPWRDNR_[A:B] | | Powerdown Receive Function. When GPWRDNR_[A:B] = 1, sections of the receive hardware for all four channels are powered down. The GPWRDNR_[A:B] bit overrides the individual PWRDNR_xx bits. GPWRDNR_[A:B] = 0 on device reset. | Both |
| | [5:6] | RSVD | | Reserved | — |
| | [7] | GTESTEN_[A:B] | | Global Test Enable Bit. When GTESTEN_[A:B] = 1, the transmit and receive sections of all channels in the block are place in test mode. The TESTMODE_xx bits (30006, 30106, etc.) must be set to specify the desired test on a per-channel basis. The GTESTEN_[A:B] bits override the individual TESTEN_xx settings. | Factory |

Table 34. Per-Channel Control Register Descriptions – ORSO82G5

| (0x) Absolute Address | Bit | Name | Reset Value (0x) | Description | Mode |
|-----------------------|-------|----------------------|------------------|---|-------|
| 30800 - AA | [0:4] | RSVD | 00 | Reserved | — |
| 30810 - AB | [5] | CELL_ALIGN_ERR_EN_xx | | '1' = Alarm enabled for CELL_ALIGN_ERR_xx | Cell |
| 30820 - AC | [6] | TX_URUN_ERR_EN_xx | | '1' = Alarm enabled for TX_URUN_ERR_xx | Cell |
| 30830 - AD | [7] | TX_ORUN_ERR_EN_xx | | '1' = Alarm enabled for TX_ORUN_ERR_xx | Cell |
| 30900 - BA | [0] | RSVD | 00 | Reserved | — |
| 30811 - AB | [1] | OOF_EN_xx | | '1' = Alarm enabled for OOF_xx | Both |
| 30821 - AC | [2] | EX_SEQ_ERR_EN_xx | | '1' = Alarm enabled for EX_SEQ_ERR_xx | Cell |
| 30831 - AD | [3] | SEQ_ERR_EN_xx | | '1' = Alarm enabled for SEQ_ERR_xx | Cell |
| 30901 - BA | [4] | CELL_BIP_ERR_EN_xx | | '1' = Alarm enabled for CELL_BIP_ERR_xx | Cell |
| 30911 - BB | [5] | B1_ERR_EN_xx | | '1' = Alarm enabled for B1_ERR_xx | Both |
| 30921 - BC | [6] | RX_FIFO_OVRUN_EN_xx | | '1' = Alarm enabled for RX_FIFO_OVRUN_xx | Cell |
| 30931 - BD | [7] | RDI_EN_xx | | '1' = Alarm enabled for RDI_xx | Both |
| 30802 - AA | [0] | ENABLE_JUST_xx | 00 | ENABLE_JUST_xx =1 causes the core to interpret pointer bytes for positive or negative justification | SONET |
| 30812 - AB | [1] | FMPU_STR_EN_xx | | FMPU_STR_EN_xx = 1 enables a channel for alignment within a multi-channel alignment group | SONET |
| 30822 - AC | [2:3] | FMPU_SYNMODE_xx | | "00" - No channel alignment "01" - Twin channel alignment "10" - 4 channel alignment "11" - By-8 alignment | SONET |
| 30832 - AD | [4] | DSCR_INH_xx | | Descrambling Inhibit, DSCR_INH = 1 inhibits descrambling (in the Rx direction) and scrambling (in the Tx direction). When inhibiting the scrambler and descrambler the AUTO_B1_xx calculated and checked B1 value will always be incorrect. | Both |
| 30902 - BA | [5] | FFRM_EN_xx | | Fast Frame Enable, FFRM_EN=1 enables the fast frame mode. | Both |
| 30912 - BB | [6] | AIS_ON_xx | | Alarm Indication Signal (control), AIS_ON =1 forces AIS-L insertion. | Both |
| 30922 - BC | [7] | AIS_ON_OOF_xx | | Alarm Indication Signal on Out of Frame, AIS_ON_OOF =1 forces AIS-L insertion during OOF =1. | Both |
| 30932 - BD | | | | | |

Table 34. Per-Channel Control Register Descriptions – ORSO82G5 (Continued)

| (0x) Absolute Address | Bit | Name | Reset Value (0x) | Description | Mode |
|--|-----|---------------------|------------------|---|-------------|
| 30803 - AA 30813 - AB 30823 - AC 30833 - AD 30903 - BA 30913 - BB 30923 - BC 30933 - BD | [0] | BYPASS_ALGN_FIFO_xx | 00 | Bypass alignment FIFO =1 in RX path in SONET mode. DOUT_xx data is clocked off RWCKxx. | SONET |
| | [1] | SERDES_ONLY_MODE_xx | | SERDES-Only Mode. SERDES_ONLY_MODE =1 bypasses all the SONET and cell functions. Data is sent directly from the SERDES to the FPGA logic in the RX path and is passed directly from the FPGA logic to the SERDES in the TX path. | SERDES Only |
| | [2] | FORCE_B1_ERR_xx | | Force B1 Error. FORCE_B1_ERR =1 forces a Section B1 error (Bit Interleaved Parity Error) in the TX path. Valid only when the corresponding AUTO_TOH_xx bit or AUTO_B1_xx bit is set to one. | Both |
| | [3] | FORCE_BIP8_ERR_xx | | Force BIP8 Error, FORCE_BIP8_ERR =1 forces cell BIP8 error in the TX path. | Cell |
| | [4] | FORCE_A1A2_ERR_xx | | Force A1A2 Error, FORCE_A1A2_ERR =1 forces an error in A1A2 bytes (framing error) in the TX path. Valid only when the corresponding AUTO_TOH_xx bit or AUTO_A1A2_xx bit is set to one. | Both |
| | [5] | FORCE_EX_SEQ_ERR_xx | | Force Excessive Sequence Errors. FORCE_EXP_SEQ_ERR_xx = 1 forces sequence errors in the TX path by inverting the link header byte sequence number. | Cell |
| | [6] | FORCE_SEQ_ERR_xx | | Force Sequence Error, FORCE_SEQ_ERR =1 forces one sequence error in the TX path. After this bit is set, the next Link Header byte's sequence number is inverted. The Link Header after the errored Link Header byte will have the correct sequence number | Cell |
| | [7] | FORCE_RDI_xx | | Force Remote Defect Indication, FORCE_RDI =1 forces RDI errors in the TX path. The K2 byte in TOH is set to '00000110'. Valid only when AUTO_TOH_xx bit is set to 1. | Cell |

Table 34. Per-Channel Control Register Descriptions – ORSO82G5 (Continued)

| (0x) Absolute Address | Bit | Name | Reset Value (0x) | Description | Mode |
|--|-------|-----------------|---|---|-------|
| 30804 - AA 30814 - AB 30824 - AC 30834 - AD 30904 - BA 30914 - BB 30924 - BC 30934 - BD | [0] | LCKREFN_xx | 00 | 0 = Lock receiver to reference clock (REFCLK) 1 = Lock receiver to HDINxx data | Both |
| | [1] | LOOPENB_xx | | LOOPENB_xx =1 Enable high-speed internal loopback from TX to RX. Disable the HDOUT buffers. | Both |
| | [2] | DISABLE_TX_xx | | Disable Transmitter, For DISABLE_TX = 1 the TX Link is disabled. The disabled link is ignored by the Output Port Controller (OPC) and internally generated idle cells are transmitted on the link. If the link is disabled during the transmission of a cell on the link, the entire cell is transmitted before the link is declared invalid. | Cell |
| | [3] | DISABLE_RX_xx | | Disable Receiver, DISABLE_RX = 1 disables the RX link for cell processing by the Input Port Controller (IPC). The IPC will not read cells from a link if this bit is set for that link | Cell |
| | [4] | CELL_BIP_INH_xx | | Cell BIP (Check) Inhibit, CELL_BIP_INH = 1 prevents cells from being dropped due to a Cell BIP error, in the RX path. If this bit is not set, then cells will be dropped automatically if a cell bip error is detected by the core. The CELL-DROP signal across the core-FPGA interface will be active only if this bit is NOT set. | Cell |
| | [5] | CELL_SEQ_INH_xx | | Cell Sequence (Checking) Inhibit, CELL_SEQ_INH = 1 prevents cells in the RX path from being dropped due to a sequence error. If this bit is not set, then cells will be dropped automatically if a sequence error is detected internally. The CELLDROP signal across the core-FPGA interface will be active only if this bit is NOT set. | Cell |
| | [6] | AUTO_TOH_xx | | Automatic TOH Generation, AUTO_TOH_xx =1 enables the TX core to automatically generate TOH bytes. All the FORCE_* register bits are valid if this bit is set. This bit should be set to 1 in Cell Mode. It can be set to 1 or 0 in SONET Mode. If this bit is not set, then user has to provide all the TOH bytes or use the AUTO_SOH mode. | SONET |
| | [7] | FMPU_RESYNC1_xx | Single channel alignment FIFO reset. Rising edge sensitive. Write a 0 and then a 1 to enable this bit. When enabled, the read pointer in the alignment FIFO is reset to the middle of the FIFO. This bit is valid only when FMPU_SYNMODE_xx = 00 (no multi channel alignment) | SONET | |
| 30805 - AA 30815 - AB 30825 - AC 30835 - AD 30905 - BA 30915 - BB 30925 - BC 30935 - BD | [0:7] | LINK_NUM_TX_xx | 00 | Transmit Link Number, This value is transmitted in the "F1" byte of the TOH. This value is used to verify that the links are connected properly and is only used in the AUTO_TOH mode. | Both |

Table 34. Per-Channel Control Register Descriptions – ORSO82G5 (Continued)

| (0x) Absolute Address | Bit | Name | Reset Value (0x) | Description | Mode |
|--|-------|--------------|------------------|--|------|
| 30806 - AA 30816 - AB 30826 - AC 30836 - AD | [0:5] | RSVD | 00 | Reserved | — |
| | [6] | AUTO_B1_xx | | AUTO_B1_xx = 0, B1 is not inserted by the embedded core AUTO_B1_xx = 1, B1 is calculated and inserted by the embedded core AUTO_TOH_xx = 1 overrides this bit | Both |
| 30906 - BA 30916 - BB 30926 - BC 30936 - BD | [7] | AUTO_A1A2_xx | | AUTO_A1A2_xx = 0, A1/A2 bytes are not inserted by the embedded core AUTO_A1A2_xx = 1, A1/A2 bytes inserted by the embedded core AUTO_TOH_xx = 1 overrides this bit | |

Table 35. Per-Channel Status Register Descriptions – ORSO82G5

| (0x) Absolute Address | Bit | Name | Reset Value (0x) | Description | Mode |
|--|-------|-------------------|------------------|---|------|
| Channel Status Registers (Read Only) xx = [AA,....,BD] | | | | | |
| 30808 - AA 30818 - AB 30828 - AC 30838 - AD 30908 - BA 30918 - BB 30928 - BC 30938 - BD | [0:4] | RSVD | 00 | Reserved | — |
| | [5] | CELL_ALIGN_ERR_xx | | Cell Alignment Error, CELL_ALIGN_ERR = 1 indicates that the internal transmit frame processor did not detect a start of cell indicator when it was expecting a new cell. If the corresponding alarm enable bit has been set, a 1 on this bit will cause an alarm. | Cell |
| | [6] | TX_URUN_ERR_xx | | Transmit Underrun Error, TX_URUN_ERR = 1 indicates an underrun error in the transmit Asynchronous FIFO. If the corresponding alarm enable bit has been set, a 1 on this bit will cause an alarm. | Cell |
| | [7] | TX_ORUN_ERR_xx | | Transmit Overrun Error, TX_ORUN_ERR = 1 indicates an overrun error in the transmit Asynchronous FIFO. The TX FIFO is designed to not overflow since it sends backpressure signal to the FPGA when it cannot accept more cells. If the corresponding alarm enable bit has been set, a 1 on this bit will cause an alarm. | Cell |

Table 35. Per-Channel Status Register Descriptions – ORSO82G5 (Continued)

| (0x) Absolute Address | Bit | Name | Reset Value (0x) | Description | Mode |
|--|-------|------------------------|------------------|---|------|
| 30809 - AA 30819 - AB 30829 - AC 30839 - AD 30909 - BA 30919 - BB 30929 - BC 30939 - BD | [0] | RSVD | 00 | Reserved | — |
| | [1] | OOF_xx | | OOF_xx = 1 indicates OOF has been detected in this link. If the corresponding alarm enable bit has been set, a 1 on this bit will cause an alarm | Both |
| | [2] | EX_SEQ_ERR_xx | | Excessive Sequence Errors, EX_SEQ_ERR = 1 indicates that three consecutive cells containing sequence errors have been detected in this link. If the corresponding alarm enable bit has been set, a 1 on this bit will cause an alarm. | Cell |
| | [3] | SEQ_ERR_xx | | Sequence Error, SEQ_ERR = 1 indicates that a sequence error has been detected for a cell on this link. If the corresponding alarm enable bit has been set, a 1 on this bit will cause an alarm. | Cell |
| | [4] | CELL_BIP_ERR_xx | | Cell mode BIP Error, CELL_BIP_ERR = 1 indicates that a BIP error has been detected in a cell on the link. If the corresponding alarm enable bit has been set, a 1 on this bit will cause an alarm. | Cell |
| | [5] | B1_ERR_xx | | Bit Interleaved Parity Error, B1_ERR = 1 indicates that a Section B1 error has been detected on the link. If the corresponding alarm enable bit has been set, a 1 on this bit will cause an alarm. | Both |
| | [6] | RX_FIFO_OVRUN_xx | | Receive FIFO Overrun, RX_FIFO_OVRUN_xx = 1 indicates that the asynchronous RX FIFO has detected an overrun condition. If the corresponding alarm enable bit has been set, a 1 on this bit will cause an alarm. | Cell |
| | [7] | RDI_xx | | Remote Defect Indication, RDI = 1 indicates that a RDI has been detected on the link. If the corresponding alarm enable bit has been set, a 1 on this bit will cause an alarm | Both |
| 3080A - AA 3081A - AB 3082A - AC 3083A - AD 3090A -BA 3091A - BB 3092A - BC 3093A - BD | [0:4] | RSVD | 00 | Reserved | — |
| | [5] | STAT_CELL_ALIGN_ERR_xx | | STAT_CELL_ALIGN_ERR_xx = 1 same as CELL_ALIGN_ERR_xx except that a 1 on this bit can NOT cause an interrupt | Cell |
| | [6] | STAT_TX_URUN_ERR_xx | | STAT_TX_URUN_ERR_xx = 1 same as TX_URUN_ERR_xx except that a 1 on this bit can NOT cause an interrupt | Cell |
| | [7] | STAT_TX_ORUN_ERR_xx | | STAT_TX_ORUN_ERR_xx = 1 same as TX_ORUN_ERR_xx except that a 1 on this bit can NOT cause an interrupt | Cell |

Table 35. Per-Channel Status Register Descriptions – ORSO82G5 (Continued)

| (0x) Absolute Address | Bit | Name | Reset Value (0x) | Description | Mode |
|--|-------|-----------------------|---|---|-------|
| 3080B - AA 3081B - AB 3082B - AC 3083B - AD 3090B - BA 3091B - BB 3092B - BC 3093B - BD | [0] | RSVD | 00 | Reserved | — |
| | [1] | STAT_OOF_xx | | STAT_OOF_xx = 1 same as OOF_xx except that a 1 on this bit can NOT cause an interrupt | Both |
| | [2] | STAT_EX_SEQ_ERR_xx | | STAT_EX_SEQ_ERR_xx = 1 same as EX_SEQ_ERR_xx except that a 1 on this bit can NOT cause an interrupt | Cell |
| | [3] | STAT_SEQ_ERR_xx | | STAT_SEQ_ERR_xx = 1 same as SEQ_ERR_xx except that a 1 on this bit can NOT cause an interrupt | Cell |
| | [4] | STAT_CELL_BIP_ERR_xx | | STAT_CELL_BIP_ERR_xx = 1 same as CELL_BIP_ERR_xx except that a 1 on this bit can NOT cause an interrupt | Cell |
| | [5] | STAT_B1_ERR_xx | | STAT_B1_ERR_xx = 1 same as B1_ERR_xx except that a 1 on this bit can NOT cause an interrupt | Both |
| | [6] | STAT_RX_FIFO_OVRUN_xx | | STAT_RX_FIFO_OVRUN_xx = 1 same as RX_FIFO_OVRUN_xx except that a 1 on this bit can NOT cause an interrupt | Cell |
| | [7] | STAT_RDI_xx | STAT_RDI_xx = 1 same as RDI_xx except that a 1 on this bit can NOT cause an interrupt | Both | |
| 3080C - AA 3081C - AB 3082C - AC 3083C - AD 3090C - BA 3091C - BB 3092C - BC 3093C - BD | [0:7] | LINK_NUM_RX_xx | 00 | Link number received that is stored in the F1 byte position of the SONET TOH | Both |
| 3080E - AA 3081E - AB 3082E - AC 3083E AD 3090E - BA 3091E - BB 3092E - BC 3093E - BD | [0:5] | RSVD | 00 | Reserved | — |
| | [6] | CH248_SYNC_xx | | CH248_SYNC_xx = 1 indicates that A1A2 bytes have been detected by link xx for multi-channel alignment | SONET |
| | [7] | RX_LINK_GOOD_xx | | RX_LINK_GOOD_xx = 1 indicates that frame has been acquired and the link has been stable. Goes high at an A1A2 boundary but can go low at any point in a frame due to excessive errors | Cell |

Table 36. Common Control Register Descriptions – ORSO82G5

| (0x) Absolute Address | Bit | Name | Reset Value (0x) | Description | Mode |
|-----------------------|-------|-------------------|------------------|--|--------------|
| 30A00 | [0:1] | RCKSELB | 00 | “00” - Channel BA source for clock RCK78B “01” - Channel BB source for clock RCK78B “10” - Channel BC source for clock RCK78B “11” - Channel BD source for clock RCK78B | Both |
| | [2:3] | TCKSELB | | “00” - Channel BA source for clock TCK78B “01” - Channel BB source for clock TCK78B “10” - Channel BC source for clock TCK78B “11” - Channel BD source for clock TCK78B | Both |
| | [4:5] | RCKSELA | | “00” - Channel AA source for clock RCK78A “01” - Channel AB source for clock RCK78A “10” - Channel AC source for clock RCK78A “11” - Channel AD source for clock RCK78A | Both |
| | [6:7] | TCKSELA | | “00” - Channel AA source for clock TCK78A “01” - Channel AB source for clock TCK78A “10” - Channel AC source for clock TCK78A “11” - Channel AD source for clock TCK78A | Both |
| 30A01 | [0:2] | CELL_SIZE | 00 | Cell Size, Three bits to set cell size. “000” - Cell size is 75 bytes, “001” - Cell size is 79 bytes, “010” - Cell size is 83 bytes, “011” - Cell size is 91 bytes These are the only supported cell sizes. | Cell |
| | [3:7] | RX_FIFO_MIN | | Set Minimum threshold value for alignment FIFO in SONET mode. When the read address for the FIFO is below this value at the time when write address is zero, it indicates that the FIFO is near overflow. This event will go high only once during a frame when a framing byte has been detected by the aligner. The default threshold value is “00000”. | SONET |
| 30A02 | 0 | TX_DISABLE_ON_RDI | 00 | Transmitter Disable on RDI (Detection), If TX_DISABLE_ON_RDI = 1 - No cell data is transmitted on a link in which a RDI has been detected by the corresponding link’s receiver. If this bit is set to 0, cell data will be transmitted on a link irrespective of detection of a RDI. | Cell |
| | [1:3] | RSVD | | Reserved | — |
| | 4 | SCHAR_ENA | | SCHAR_ENA = 1 enables SERDES characterization of SERDES B. Refer to section | Factory Test |
| | 5 | SCHAR_TXSEL | | SCHAR_TXSEL =1 is a Select Tx option which will cause chip ports to directly control the SERDES low-speed transmit ports of one of the channels selected by SCHAR_CHAN | Factory Test |
| | 6:7 | SCHAR_CHAN | | “00” - Select channel BA to test “01” - Select channel BB to test “10” - Select channel BC to test “11” - Select channel BD to test | Factory Test |

Table 36. Common Control Register Descriptions – ORSO82G5 (Continued)

| (0x) Absolute Address | Bit | Name | Reset Value (0x) | Description | Mode |
|-----------------------|-----|-----------------|------------------|--|------|
| 30A03 | [0] | NO_TX_RDI_EXSEQ | 00 | Not Transmission of RDI, If NO_TX_RDI_EXSEQ = 1, a transmit link will not send data if its corresponding receive link is not good due to excessive sequence errors. If this bit is set to 0, a transmit link will still send data even if its corresponding receive link has excessive sequence errors. This bit should always be set during simulation and in SONET mode. | Both |
| | [1] | AUTO_BUNDLE | | Automatic (Link) Bundle, AUTO_BUNDLE = 1 allows a link within a link group to remain active even when another link within that group is defective. Cell data from all links within that group will continue to be sent to the FPGA. If this bit is set to 0, then all links within a link group must be good before cell data are read from the links by the IPC and passed to the FPGA. | Cell |
| | [2] | RSVD | | Reserved | — |
| | [3] | REJOIN_A | | Link Rejoin, REJOIN = 1 forces any link in a SERDES block to reassert a “RX link good” signal automatically when three consecutive sequence numbers are correct on that link. | Cell |
| | [4] | AUTO_REMOVE_A | | Automatic (Link) Remove, AUTO_REMOVE = 1 indicates that any link in a SERDES block which sees three excessive sequence errors should deassert the “RX link good” signal which will cause the link to be inactive. | Cell |
| | [5] | RSVD | | Reserved | — |
| | [6] | REJOIN_B | | Link Rejoin, REJOIN = 1 forces any link in a SERDES block to reassert a “RX link good” signal automatically when three consecutive sequence numbers are correct on that link. | Cell |
| | [7] | AUTO_REMOVE_B | | AUTO_REMOVE_B = 1 indicates that any link in SERDES block B which sees three excessive sequence errors should deassert the “RX link good” signal which will cause the link to be inactive. | Cell |

Table 36. Common Control Register Descriptions – ORSO82G5 (Continued)

| (0x) Absolute Address | Bit | Name | Reset Value (0x) | Description | Mode |
|-----------------------|-----|-----------------|------------------|--|-------|
| 30A04 | [0] | RSVD | 00 | Reserved | — |
| | [1] | FMPU_RESYNC4_B | | Control to resync 4 channels which have been configured for multi channel alignment in SONET mode in block B. Requires a rising edge on this bit. Write a 0 followed by a 1. | SONET |
| | [2] | FMPU_RESYNC2_B2 | | Control to resync channels BC and BD which have been configured for multi channel alignment in SONET mode in block B. Requires a rising edge on this bit. Write a 0 followed by a 1. | SONET |
| | [3] | FMPU_RESYNC2_B1 | | Control to resync channels BA and BB which have been configured for multi channel alignment in SONET mode in block B. Requires a rising edge on this bit. Write a 0 followed by a 1. | SONET |
| | [4] | FMPU_RESYNC4_A | | Control to resync 4 channels which have been configured for multi channel alignment in SONET mode in block A. Requires a rising edge on this bit. Write a 0 followed by a 1. | SONET |
| | [5] | FMPU_RESYNC2_A2 | | Control to resync channels AC and AD which have been configured for multi channel alignment in SONET mode in block A. Requires a rising edge on this bit. Write a 0 followed by a 1. | SONET |
| | [6] | FMPU_RESYNC2_A1 | | Control to resync channels AA and AB which have been configured for multi channel alignment in SONET mode in block A. Requires a rising edge on this bit. Write a 0 followed by a 1. | SONET |
| | [7] | FMPU_RESYNC8 | | Control to resync all 8 channels which have been configured for multi channel alignment. | SONET |

Table 36. Common Control Register Descriptions – ORSO82G5 (Continued)

| (0x) Absolute Address | Bit | Name | Reset Value (0x) | Description | Mode |
|-----------------------|-------|---------------|------------------|--|------|
| 30A05 | [0:2] | ERRCNT_CH | 00 | Error Count Channel Select, Control bits to select which channel's Section B1 error and Cell BIP error counts are recorded by the BIP_ERR_CNT and CELL_BIP_ERR_CNT registers. "000" - Channel AA, "001" - Channel AB, "010" - Channel AC, "011" - Channel AD, "100" - Channel BA, "101" - Channel BB, "110" - Channel BC, "111" - Channel BD | Both |
| | [3] | CELL_MODE_A1 | | Cell Mode Enable, CELL_MODE_A1 = 1 enables cell mode for the channel group AA and AB. | Cell |
| | [4] | CELL_MODE_A2 | | Cell Mode Enable, CELL_MODE_A2 = 1 enables cell mode for the channel group AC and AD. | Cell |
| | [5] | CELL_MODE_B1 | | Cell Mode Enable, CELL_MODE_B1 = 1 enables cell mode for the channel group BA and BB. | Cell |
| | [6] | CELL_MODE_B2 | | Cell Mode Enable, CELL_MODE_B2 = 1 enables cell mode for the channel group BC and BD. | Cell |
| | [7] | CELL_MODE_ALL | | Cell Mode Enable, CELL_MODE_ALL = 1 enables cell mode for 8-link cell mode. CELL_MODE_[A1,A2,B1,B2] bits are not valid. | Cell |
| 30A06 | [0:4] | RSVD | 00 | Reserved | — |
| | [5:6] | RESET_PHASE | | Reset Phase, Two bits to select delay phase for delaying the soft reset bit SOFT_RESET with respect to the synchronizing clock. Four delay phases can be selected through the values "00", "01", "10" and "11". | Both |
| | [7] | SOFT_RESET | | Soft Reset, SOFT_RESET=1 resets the embedded core flip flops except for the software registers. This bit does not affect the state of the registers inside the SERDES blocks. | Both |
| 30A07 | [0:6] | RSVD | 00 | Reserved | — |
| | [7] | TX_CFG_DONE | | Transmitter Configuration Done, Edge sensitive bit to indicate that all TX configuration bits are set. After all register bits have been set for Transmit direction, write a 0 and then a 1 to this bit. | Cell |

Table 36. Common Control Register Descriptions – ORSO82G5 (Continued)

| (0x) Absolute Address | Bit | Name | Reset Value (0x) | Description | Mode |
|-----------------------------|-------|------------------|------------------------|---|------|
| 30A08 | [0] | ALARM_STATUS_BD | 00 | Alarm Status Indicator, This bit is an OR of all alarm status bits for the channel BD. A 1 on this bit will also set the alarm pin on the system bus interrupt cause register (on the FPGA side). | Both |
| | [1] | ALARM_STATUS_BC | | Alarm Status Indicator, This bit is an OR of all alarm status bits for the channel BC. A 1 on this bit will also set the alarm pin on the system bus interrupt cause register (on the FPGA side). | Both |
| | [2] | ALARM_STATUS_BB | | Alarm Status Indicator, This bit is an OR of all alarm status bits for the channel BB. A 1 on this bit will also set the alarm pin on the system bus interrupt cause register (on the FPGA side). | Both |
| | [3] | ALARM_STATUS_BA | | Alarm Status Indicator, This bit is an OR of all alarm status bits for the channel BA. A 1 on this bit will also set the alarm pin on the system bus interrupt cause register (on the FPGA side). | Both |
| | [4] | ALARM_STATUS_AD | | Alarm Status Indicator, This bit is an OR of all alarm status bits for the channel AD. A 1 on this bit will also set the alarm pin on the system bus interrupt cause register (on the FPGA side). | Both |
| | [5] | ALARM_STATUS_AC | | Alarm Status Indicator, This bit is an OR of all alarm status bits for the channel AC. A 1 on this bit will also set the alarm pin on the system bus interrupt cause register (on the FPGA side). | Both |
| | [6] | ALARM_STATUS_AB | | OR of all alarm status bits for channel AB. A 1 on this bit will set the alarm pin on the system bus interrupt cause register (on the FPGA side) | Both |
| | [7] | ALARM_STATUS_AA | | Alarm Status Indicator, This bit is an OR of all alarm status bits for the channel AA. A 1 on this bit will also set the alarm pin on the system bus interrupt cause register (on the FPGA side). | Both |
| 30A09 | [0:7] | B1_ERR_CNT | 00 | Error counter that increments when a section B1 error is detected on a link. The link is selected using ERRCNT_CHSEL. This counter is cleared on read. | Both |
| 30A0A | [0:7] | CELL_BIP_ERR_CNT | 00 | Cell BIP Error Counter, Error counter that increments when a Cell BIP error is detected on a link. The link being monitored is selected using ERRCNT_CHSEL. This counter is cleared on read. | Cell |

Table 36. Common Control Register Descriptions – ORSO82G5 (Continued)

| (0x) Absolute Address | Bit | Name | Reset Value (0x) | Description | Mode |
|-----------------------|-------|---------------|------------------|---|-------|
| 30A0B | [0:2] | RSVD | 00 | Reserved | — |
| | [3] | CELL_DRP_B2 | | Cell Drop, CELL_DRP_B2 = 1 indicates that a cell has been dropped from the link group BC and BD | Cell |
| | [4] | CELL_DRP_B1 | | Cell Drop, CELL_DRP_B1 = 1 indicates that a cell has been dropped from the link group BB and BA | Cell |
| | [5] | CELL_DRP_A2 | | Cell Drop, CELL_DRP_A2 = 1 indicates that a cell has been dropped from the link group AC and AD | Cell |
| | [6] | CELL_DRP_A1 | | Cell Drop, CELL_DRP_A1 = 1 indicates that a cell has been dropped from the link group AB and AA | Cell |
| | [7] | CELL_DRP_ALL8 | | CELL_DRP_ALL8 = 1 indicates that cells have been dropped on link group comprising of all 8 channels | Cell |
| 30A0C | [0] | RSVD | 00 | Reserved | — |
| | [1] | SYNC4_B_OOS | | SYNC4_B_OOS = 1 indicates that channels cannot be aligned within the 4 links in block B in SONET mode | SONET |
| | [2] | SYNC2_B2_OOS | | SYNC2_B2_OOS = 1 indicates that channels cannot be aligned within the links BC and BD in SONET mode | SONET |
| | [3] | SYNC2_B1_OOS | | SYNC2_B1_OOS = 1 indicates that channels cannot be aligned within the links BB and BA in SONET mode | SONET |
| | [4] | SYNC4_A_OOS | | SYNC4_A_OOS = 1 indicates that channels cannot be aligned within the 4 links in block A in SONET mode | SONET |
| | [5] | SYNC2_A2_OOS | | SYNC2_A2_OOS = 1 indicates that channels cannot be aligned within the AC and AD links in SONET mode | SONET |
| | [6] | SYNC2_A1_OOS | | SYNC2_A1_OOS = 1 indicates that channels cannot be aligned within the AB and AD links in SONET mode | SONET |
| | [7] | SYNC8_OOS | | SYNC8_OOS = 1 indicates that channels cannot be aligned within the 8 channels in SONET mode | SONET |

Table 36. Common Control Register Descriptions – ORSO82G5 (Continued)

| (0x) Absolute Address | Bit | Name | Reset Value (0x) | Description | Mode |
|-----------------------|-------|--------------------|------------------|---|-------|
| 30A0D | [0] | RSVD | 00 | Reserved | — |
| | [1] | SYNC4_B_OVFL | | SYNC8_OOS = 1 indicates that the alignment FIFO(s) in the links in block B are near overflow (i.e., at the time of writing into address 0, the read address was less than RX_FIFO_MIN) | SONET |
| | [2] | SYNC2_B2_OVFL | | SYNC2_B2_OVFL = 1 indicates that the alignment FIFO(s) in the links BC and BD are near overflow (i.e., at the time of writing into address 0, the read address was less than RX_FIFO_MIN) | SONET |
| | [3] | SYNC2_B1_OVFL | | SYNC2_B1_OVFL = 1 indicates that the alignment FIFO(s) in the links BA and BB are near overflow (i.e., at the time of writing into address 0, the read address was less than RX_FIFO_MIN) | SONET |
| | [4] | SYNC4_A_OVFL | | SYNC4_A_OVFL = 1 indicates that the alignment FIFO(s) in the links in block A are near overflow (i.e., at the time of writing into address 0, the read address was less than RX_FIFO_MIN) | SONET |
| | [5] | SYNC2_A2_OVFL | | SYNC2_A2_OVFL = 1 indicates that the alignment FIFO(s) in the links AC and AD are near overflow (i.e., at the time of writing into address 0, the read address was less than RX_FIFO_MIN) | SONET |
| | [6] | SYNC2_A1_OVFL | | SYNC2_A1_OVFL = 1 indicates that the alignment FIFO(s) in the links AA and AB are near overflow (i.e., at the time of writing into address 0, the read address was less than RX_FIFO_MIN) | SONET |
| | [7] | SYNC8_OVFL | | SYNC8_OVFL = 1 Indicates that the alignment FIFO(s) in eight-links are near overflow (At the time of writing into address 0, the read address was less than RX_FIFO_MIN) | SONET |
| 30A0E | [0:2] | RSVD | 00 | Reserved | — |
| | [3] | BDL_ALIGN_ERR_B2 | | Alignment Error, BDL_ALIGN_ERR = 1 indicates that an alignment error has occurred in the link group pairs BC and BD | Cell |
| | [4] | BDL_ALIGN_ERR_B1 | | Alignment Error, BDL_ALIGN_ERR = 1 indicates that an alignment error has occurred in the link group pairs BA and BB | Cell |
| | [5] | BDL_ALIGN_ERR_A2 | | Alignment Error, BDL_ALIGN_ERR = 1 indicates that an alignment error has occurred in the link group pairs AC and AD | Cell |
| | [6] | BDL_ALIGN_ERR_A1 | | Alignment Error, BDL_ALIGN_ERR = 1 indicates that an alignment error has occurred in the link group pairs AA and AB | Cell |
| | [7] | BDL_ALIGN_ERR_ALL8 | | BDL_ALIGN_ERR_ALL8 = 1 -indicates that an alignment error has occurred in cell group of all eight-links | Cell |

Absolute Maximum Ratings

Stresses in excess of the absolute maximum ratings can cause permanent damage to the device. These are absolute stress ratings only. Functional operation of the device is not implied at these or any other conditions in excess of those given in the operations sections of this data sheet. Exposure to absolute maximum ratings for extended periods can adversely affect device reliability.

The ORCA Series 4 FPSCs include circuitry designed to protect the chips from damaging substrate injection currents and to prevent accumulations of static charge. Nevertheless, conventional precautions should be observed during storage, handling, and use to avoid exposure to excessive electrical stress.

Table 37. Absolute Maximum Ratings

| Parameter | Symbol | Min. | Max. | Units |
|--|-----------------------------------|----------------|------------------|-------|
| Storage Temperature | T_{STG} | -65 | 150 | °C |
| Power Supply Voltage with Respect to Ground | V_{DD33} | -0.3 | 4.2 | V |
| | V_{DDIO} | -0.3 | 4.2 | V |
| | $V_{DD15}, V_{DD_ANA}, V_{DDGB}$ | -0.3 | 2.0 | V |
| Input Signal with Respect to Ground | V_{IN} | $V_{SS} - 0.3$ | $V_{DDIO} + 0.3$ | V |
| Signal Applied to High-Impedance Output | — | $V_{SS} - 0.3$ | $V_{DDIO} + 0.3$ | V |
| Maximum Package Body (Soldering) Temperature | — | — | 220 | °C |

Recommended Operating Conditions

Table 38. Recommended Operating Conditions

| Parameter | Symbol | Min. | Max. | Units |
|--|-------------------------|----------------|------------------|-------|
| Power Supply Voltage with Respect to Ground ¹ | V_{DD33} | 3.0 | 3.6 | V |
| | V_{DD15} | 1.425 | 1.575 | V |
| Input Voltages | V_{IN} | $V_{SS} - 0.3$ | $V_{DDIO} + 0.3$ | V |
| Junction Temperature | T_J | -40 | 125 | °C |
| SERDES Supply Voltage | V_{DD_ANA}, V_{DDGB} | 1.425 | 1.575 | V |
| SERDES CML I/O Supply Voltage | V_{DDIB}, V_{DDOB} | 1.425 | 1.89 | V |

1. For FPGA Recommended Operating Conditions and Electrical Characteristics, see the Recommended Operating Conditions and Electrical Characteristics tables in the ORCA Series 4 FPGA data sheet (OR4E04) and technical note TN1036, *ORCA Series 4 I/O User's Guide*. FPSC Standby Currents (IDDSB15 and IDDSB33) are tested with the Embedded Core in the powered down state.

SERDES Electrical and Timing Characteristics

Table 39. Maximum Power Dissipation

| Parameter | Conditions | Min. | Typ. | Max. ¹ | Units |
|----------------------------|--|------|------|-------------------|-------|
| Power Dissipation ORSO82G5 | SERDES, MUX/DEMUX, Align FIFO and I/O (Per Channel), 1.25 Gbit/s | — | — | 195 | mW |
| | SERDES, MUX/DEMUX, Align FIFO and I/O (Per Channel), 2.5 Gbit/s | — | — | 225 | mW |
| | Logic Active in Both SONET and Cell Modes (Per Channel) | — | — | 25 | mW |
| | Logic Active Only in Cell Mode (Per Channel) | — | — | 10 | mW |
| Power Dissipation ORSO42G5 | SERDES, MUX/DEMUX, Align FIFO and I/O (Per Channel), 1.25 Gbit/s | — | — | 265 | mW |
| | SERDES, MUX/DEMUX, Align FIFO and I/O (Per Channel), 2.5 Gbit/s | — | — | 295 | mW |
| | Logic Active in Both SONET and Cell Modes (Per Channel) | — | — | 25 | mW |
| | Logic Active Only in Cell Mode (Per Channel) | — | — | 10 | mW |

1. With all channels operating, 1.575V supply.

High Speed Data Transmitter

Table 40 specifies serial data output buffer parameters measured on devices with typical and worst case process parameters and over the full range of operation conditions.

Table 40. Serial Output Timing and Levels (CML I/O)

| Parameter | Min. | Typ. | Max. | Units |
|--|--------------|--------------|--------------|-------|
| Rise Time (20% - 80%) | 50 | 80 | 110 | ps |
| Fall Time (80% - 20%) | 50 | 80 | 110 | ps |
| Common Mode | VDDOB – 0.30 | VDDOB – 0.25 | VDDOB – 0.15 | V |
| Differential Swing (Full Amplitude) ¹ | 750 | 900 | 1000 | mVp-p |
| Differential Swing (Half Amplitude) ¹ | 375 | 450 | 500 | mVp-p |
| Output Load (External) | — | 86 | — | Ω |

1. Differential swings measured at the end of 3 inches of FR-4 and 12 inches of coax cable.

Transmitter output jitter is a critical parameter to systems with high speed data links. Table 41 and Table 42 specify the transmitter output jitter for typical and worst case devices over the full range of operating conditions.

Table 41. Channel Output Jitter (2.7 Gbps)

| Parameter | Device | Min. | Typ. ¹ | Max. ¹ | Units |
|---------------------|----------|------|-------------------|-------------------|-------|
| Deterministic | ORSO42G5 | — | 0.12 | 0.16 | Ulp-p |
| | ORSO82G5 | — | 0.12 | 0.16 | Ulp-p |
| Random ² | ORSO42G5 | — | 0.05 | 0.18 | Ulp-p |
| | ORSO82G5 | — | 0.05 | 0.08 | Ulp-p |
| Total ³ | ORSO42G5 | — | 0.17 | 0.34 | Ulp-p |
| | ORSO82G5 | — | 0.17 | 0.24 | Ulp-p |

1. With PRBS 2⁷-1 data pattern, all channels operating, FPGA logic active, REFCLK jitter of 30 ps., 0°C to 85°C, 1.425V to 1.575V supply.

2. Wavecrest SIA-3000 instrument used to measure one-sigma (RMS) random jitter component value. This value is multiplied by 14 to provide the peak-to-peak value that corresponds to a BER of 10⁻¹².

3. Total jitter measurement performed with Wavecrest SIA-3000 at a BER of 10⁻¹². See instrument documentation and other Wavecrest publications for a detailed discussion of jitter types included in this measurement.

Table 42. Channel Output Jitter (2.5 Gbps)

| Parameter | Device | Min. | Typ. ¹ | Max. ¹ | Units |
|---------------------|----------|------|-------------------|-------------------|-------|
| Deterministic | ORSO42G5 | — | 0.11 | 0.13 | Ulp-p |
| | ORSO82G5 | — | 0.11 | 0.13 | Ulp-p |
| Random ² | ORSO42G5 | — | 0.05 | 0.14 | Ulp-p |
| | ORSO82G5 | — | 0.05 | 0.07 | Ulp-p |
| Total ³ | ORSO42G5 | — | 0.16 | 0.27 | Ulp-p |
| | ORSO82G5 | — | 0.16 | 0.20 | Ulp-p |

1. With PRBS 2⁷-1 data pattern, all channels operating, FPGA logic active, REFCLK jitter of 30 ps., 0°C to 85°C, 1.425V to 1.575V supply.

2. Wavecrest SIA-3000 instrument used to measure one-sigma (RMS) random jitter component value. This value is multiplied by 14 to provide the peak-to-peak value that corresponds to a BER of 10⁻¹².

3. Total jitter measurement performed with Wavecrest SIA-3000 at a BER of 10⁻¹². See instrument documentation and other Wavecrest publications for a detailed discussion of jitter types included in this measurement.

High Speed Data Receiver

Table 43 specifies receiver parameters measured on devices with worst case process parameters and over the full range of operation conditions.

Table 43. External Data Input Specifications

| Parameter | Conditions | Min. | Typ. | Max. | Units |
|---|---------------|----------------|------|---------------------|----------|
| Input Data | | | | | |
| Stream of Nontransitions | Scrambler off | — | | 72 | Bits |
| Sensitivity (differential), worst-case ¹ | 2.7Gbps | 80 | | — | mVp-p |
| Input Levels ² | — | $V_{SS} - 0.3$ | — | $V_{DD_ANA} + 0.3$ | V |
| Internal Buffer Resistance (Each input to VDDIB) | — | 40 | 50 | 60 | Ω |
| PLL Lock Time ³ | — | — | — | Note 2 | — |

1. With PRBS 2[^]7-1 data pattern, all channels operating, FPGA logic active, REFCLK jitter of 30 ps., TA = 0°C to 85°C, 1.425V to 1.575V supply.

2. Input level min + (input peak to peak swing)/2 ≤ common mode input voltage ≤ input level max - (input peak to peak swing)/2

3. The ORT82G5 SERDES receiver performs four levels of synchronization on the incoming serial data stream, providing first bit, then byte (character), then channel (32-bit word), and finally optional multi-channel alignment as described in TN1025. The PLL Lock Time is the time required for the CDR PLL to lock to the transitions in the incoming high-speed serial data stream. If the PLL is unable to lock to the serial data stream, it instead locks to REFCLK to stabilize the voltage-controlled oscillator (VCO), and periodically switches back to the serial data stream to again attempt synchronization.

Input Data Jitter Tolerance

A receiver's ability to tolerate incoming signal jitter is very dependent on jitter type. High speed serial interface standards have recognized the dependency on jitter type and have recently modified specifications to indicate tolerance levels for different jitter types as they relate to specific protocols. Sinusoidal jitter is considered to be a worst case jitter type. Table 44 shows receiver specifications with 10 MHz sinusoidal jitter injection. Other jitter tolerance measurements were measured in a separate experiment detailed in technical note TN1032, *SERDES Test Chip Jitter*, and are not reflected in these results.

Table 44. Receiver Sinusoidal Jitter Tolerance Specifications

| Parameter | Conditions | Max. | Unit |
|--|------------------------------|------|-------|
| Input Data | | | |
| Jitter Tolerance @ 2.7Gbps, Typical | 600 mV diff eye ¹ | 0.75 | UIP-P |
| Jitter Tolerance @ 2.7Gbps, Worst case | 600 mV diff eye ¹ | 0.65 | UIP-P |
| Jitter Tolerance @ 2.5Gbps, Typical | 600 mV diff eye ¹ | 0.79 | UIP-P |
| Jitter Tolerance @ 2.5Gbps, Worst case | 600 mV diff eye ¹ | 0.67 | UIP-P |

1. With PRBS 2[^]7-1 data pattern, all channels operating, FPGA logic active, REFCLK jitter of 30 ps., TA = 0°C to 85°C, 1.425V to 1.575V supply. Jitter measured with a Wavecrest SIA-3000.

Input Eye-Mask Characterization

Figure 51 provides an eye-mask characterization of the SERDES receiver input. The eye-mask is specified below for two different eye-mask heights. It provides guidance on a number of input parameters, including signal amplitude and rise time limits, noise and jitter limits, and P and N input skew tolerance. Almost all detrimental characteristics of transmit signal and the interconnection link design result in eye-closure. This, combined with the eye-opening limitations of the line receiver, can provide a good indication of a link's ability to transfer data error-free.

The Clock and Data Recovery (CDR) portion of the ORSO42G5 and ORSO82G5 SERDES receiver has the ability to filter incoming signal jitter that is below the clock recovery PLL bandwidth (about 3 MHz). The eye-mask specifications of Table 45 are for jitter frequencies above the PLL bandwidth of the CDR, which is a worst case condition. When jitter occurs at frequencies below the PLL bandwidth, the receiver jitter tolerance is significantly better. For this case error-free data detection can occur even with a completely closed eye-mask.

Figure 51. Receive Data Eye-Diagram Template (Differential)

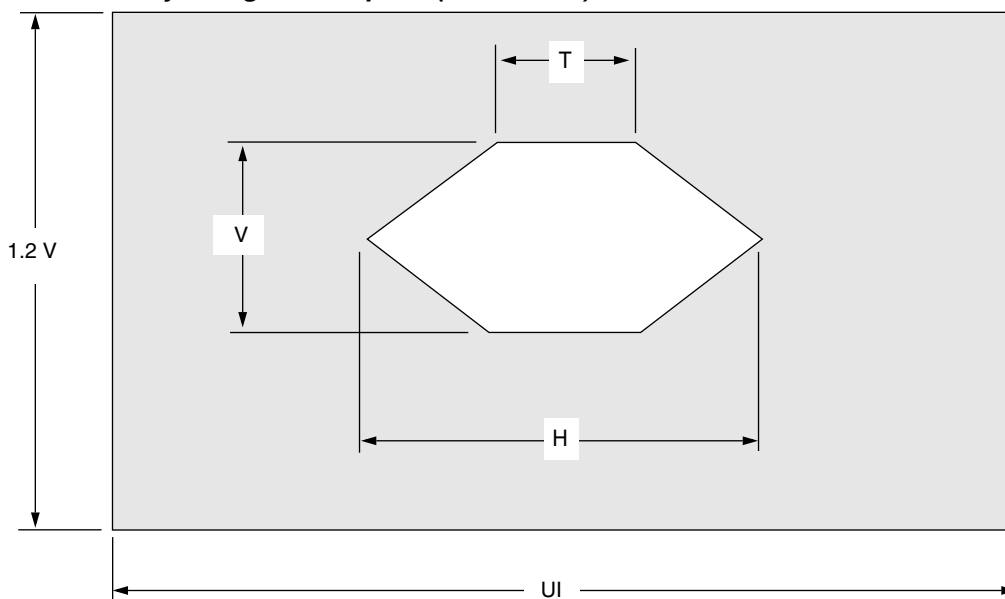

Table 45. Receiver Eye-Mask Specifications¹

| Parameter | Conditions | Value | Unit |
|--------------------------------|----------------------------|-------|-------|
| Input Data | | | |
| Eye Opening Width (H)@ 2.7Gbps | V=175 mV diff ¹ | 0.55 | UIP-P |
| Eye Opening Width (T)@ 2.7Gbps | V=175 mV diff ¹ | 0.15 | UIP-P |
| Eye Opening Width (H)@ 2.7Gbps | V=600 mV diff ¹ | 0.35 | UIP-P |
| Eye Opening Width (T)@ 2.7Gbps | V=600 mV diff ¹ | 0.10 | UIP-P |
| Eye Opening Width (H)@ 2.5Gbps | V=175 mV diff ¹ | 0.42 | UIP-P |
| Eye Opening Width (T)@ 2.5Gbps | V=175 mV diff ¹ | 0.15 | UIP-P |
| Eye Opening Width (H)@ 2.5Gbps | V=600 mV diff ¹ | 0.33 | UIP-P |
| Eye Opening Width (T)@ 2.5Gbps | V=600 mV diff ¹ | 0.10 | UIP-P |

1. With PRBS 2⁷-1 data pattern, 10 MHz sinusoidal jitter, all channels operating, FPGA logic active, REFCLK jitter of 30 ps., T_A = 0°C to 85°C, 1.425V to 1.575V supply.

External Reference Clock

The external reference clock selection and its interface are a critical part of system applications for this product. Table 46 specifies reference clock requirements, over the full range of operating conditions. The designer is encouraged to read TN1040, *SERDES Reference Clock*, which discusses various aspects of this system element and its interconnection.

Table 46. Reference Clock Specifications (REFCLKP_[A:B] and REFCLKN_[A:B])

| Parameter | Min. | Typ. | Max. | Units |
|--|------------------------------|------|--|-------------------|
| Frequency Range | 60 | — | 185 | MHz |
| Frequency Tolerance ¹ | -350 | — | 350 | ppm |
| Duty Cycle (Measured at 50% Amplitude Point) | 40 | 50 | 60 | % |
| Rise Time | — | 500 | 1000 | ps |
| Fall Time | — | 500 | 1000 | ps |
| P–N Input Skew | — | — | 75 | ps |
| Differential Amplitude | 500 | 800 | 2 x VDDIB | mV _{p-p} |
| Common Mode Level | V _{single-ended} /2 | 0.75 | VDD15 – (V _{single-ended} /2) | V |
| Single-Ended Amplitude | 250 | 400 | VDDIB | mV _{p-p} |
| Input Capacitance (at REFCLKP_[A:B]) | — | — | 5 | pF |
| Input Capacitance (at REFCLKN_[A:B]) | — | — | 5 | pF |

1. This specification indicates the capability of the high speed receiver CDR PLL to acquire lock when the reference clock frequency and incoming data rate are not synchronized.

Pin Descriptions

This section describes the pins found on the Series 4 FPGAs. Any pin not described in this table is a user-programmable I/O. During configuration, the user-programmable I/Os are 3-stated with an internal pull-up resistor. If any pin is not used (or not bonded to a package pin), it is also 3-stated with an internal pull-up resistor after configuration. The pin descriptions in Table 47 and throughout this data sheet show active-low signals with an overscore. The package pinout tables that follow, show this as a signal ending with $_N$. For example \overline{LDC} and LDC_N are equivalent.

Table 47. Pin Descriptions

| Symbol | I/O | Description |
|-----------------------------|-----|---|
| Dedicated Pins | | |
| VDD33 | — | 3.3V positive power supply. This power supply is used for 3.3V configuration RAMs and internal PLLs. When using PLLs, this power supply should be well isolated from all other power supplies on the board for proper operation. |
| VDD15 | — | 1.5V positive power supply for internal logic. |
| VDDIO | — | Positive power supply used by I/O banks. |
| VSS | — | Ground. |
| PTEMP | I | Temperature sensing diode pin. Dedicated input. |
| \overline{RESET} | I | During configuration, \overline{RESET} forces the restart of configuration and a pull-up is enabled. After configuration, \overline{RESET} can be used as a general FPGA input or as a direct input, which causes all PLC latches/FFs to be asynchronously set/reset. |
| CCLK | O | In the master and asynchronous peripheral modes, CCLK is an output which strobes configuration data in. |
| | I | In the slave or readback after configuration, CCLK is input synchronous with the data on DIN or D[7:0]. CCLK is an output for daisy-chain operation when the lead device is in master, peripheral, or system bus modes. |
| DONE | I | As an input, a low level on DONE delays FPGA start-up after configuration. ¹ |
| | O | As an active-high, open-drain output, a high level on this signal indicates that configuration is complete. DONE has an optional pull-up resistor. |
| PRGRM | I | PRGRM is an active-low input that forces the restart of configuration and resets the boundary-scan circuitry. This pin always has an active pull-up. |
| RD_CFG | I | This pin must be held high during device initialization until the INIT pin goes high. This pin always has an active pull-up. During configuration, RD_CFG is an active-low input that activates the TS_ALL function and 3-states all of the I/O. After configuration, $\overline{RD_CFG}$ can be selected (via a bit stream option) to activate the TS_ALL function as described above, or, if readback is enabled via a bit stream option, a high-to-low transition on $\overline{RD_CFG}$ will initiate readback of the configuration data, including PFU output states, starting with frame address 0. |
| RD_DATA/TDO | O | RD_DATA/TDO is a dual-function pin. If used for readback, RD_DATA provides configuration data out. If used in boundary-scan, TDO is test data out. |
| CFG_IRQ/MPI_IRQ | O | During JTAG, slave, master, and asynchronous peripheral configuration assertion on this $\overline{CFG_IRQ}$ (active-low) indicates an error or errors for block RAM or FPSC initialization. MPI active-low interrupt request output, when the MPI is used. |
| LVDS_R | — | Reference resistor connection for controlled impedance termination of Series 4 FPGA LVDS inputs. |
| Special-Purpose Pins | | |
| M[3:0] | I | During powerup and initialization, M0—M3 are used to select the configuration mode with their values latched on the rising edge of \overline{INIT} . During configuration, a pull-up is enabled. |
| | I/O | After configuration, these pins are user-programmable I/O. ¹ |
| PLL_CK[0:7][TC] | I | Semi-dedicated PLL clock pins. During configuration they are 3-stated with a pull up. |
| | I/O | These pins are user-programmable I/O pins if not used by PLLs after configuration. |

Table 47. Pin Descriptions (Continued)

| Symbol | I/O | Description |
|---------------------|-----|---|
| P[TBLR]CLK[1:0][TC] | I | Pins dedicated for the primary clock. Input pins on the middle of each side with differential pairing. |
| | I/O | After configuration these pins are user programmable I/O, if not used for clock inputs. |
| TDI, TCK, TMS | I | If boundary-scan is used, these pins are test data in, test clock, and test mode select inputs. If boundary-scan is not selected, all boundary-scan functions are inhibited once configuration is complete. Even if boundary-scan is not used, either TCK or TMS must be held at logic 1 during configuration. Each pin has a pull-up enabled during configuration. |
| | I/O | After configuration, these pins are user-programmable I/O if boundary scan is not used. ¹ |
| RDY/BUSY/RCLK | O | During configuration in asynchronous peripheral mode, RDY/RCLK indicates another byte can be written to the FPGA. If a read operation is done when the device is selected, the same status is also available on D7 in asynchronous peripheral mode. During the master parallel configuration mode, RCLK is a read output signal to an external memory. This output is not normally used. |
| | I/O | After configuration this pin is a user-programmable I/O pin. ¹ |
| HDC | O | High During Configuration is output high until configuration is complete. It is used as a control output, indicating that configuration is not complete. |
| | I/O | After configuration, this pin is a user-programmable I/O pin. ¹ |
| LDC | O | Low During Configuration is output low until configuration is complete. It is used as a control output, indicating that configuration is not complete. |
| | I/O | After configuration, this pin is a user-programmable I/O pin. ¹ |
| INIT | I/O | INIT is a bidirectional signal before and during configuration. During configuration, a pull-up is enabled, but an external pull-up resistor is recommended. As an active-low open-drain output, INIT is held low during power stabilization and internal clearing of memory. As an active-low input, INIT holds the FPGA in the wait-state before the start of configuration. After configuration, this pin is a user-programmable I/O pin. ¹ |
| CS0, CS1 | I | CS0 and CS1 are used in the asynchronous peripheral, slave parallel, and microprocessor configuration modes. The FPGA is selected when CS0 is low and CS1 is high. During configuration, a pull-up is enabled. |
| | I/O | After configuration, if MPI is not used, these pins are user-programmable I/O pins. ¹ |
| RD/MPI_STRB | I | RD is used in the asynchronous peripheral configuration mode. A low on RD changes D[7:3] into a status output. WR and RD should not be used simultaneously. If they are, the write strobe overrides. This pin is also used as the MPI data transfer strobe. As a status indication, a high indicates ready, and a low indicates busy. |
| WR/MPI_RW | I | WR is used in asynchronous peripheral mode. A low on WR transfers data on D[7:0] to the FPGA. In MPI mode, a high on MPI_RW allows a read from the data bus, while a low causes a write transfer to the FPGA. |
| | I/O | After configuration, if the MPI is not used, WR/MPI_RW is a user-programmable I/O pin. ¹ |
| PPC_A[14:31] | I | During MPI mode the PPC_A[14:31] are used as the address bus driven by the PowerPC bus master utilizing the least-significant bits of the PowerPC 32-bit address. |
| MPI_BURST | I | MPI_BURST is driven low to indicate a burst transfer is in progress in MPI mode. Driven high indicates that the current transfer is not a burst. |
| MPI_BDIP | I | MPI_BDIP is driven by the PowerPC processor in MPI mode. Assertion of this pin indicates that the second beat in front of the current one is requested by the master. Negated before the burst transfer ends to abort the burst data phase. |
| MPI_TSZ[0:1] | I | MPI_TSZ[0:1] signals are driven by the bus master in MPI mode to indicate the data transfer size for the transaction. Set 01 for byte, 10 for half-word, and 00 for word. |
| A[21:0] | O | During master parallel mode A[21:0] address the configuration EPROMs up to 4M bytes. |
| | I/O | If not used for MPI these pins are user-programmable I/O pins after configuration. ¹ |

Table 47. Pin Descriptions (Continued)

| Symbol | I/O | Description |
|----------------------------|-----|---|
| MPI_ACK | O | In MPI mode this is driven low indicating the MPI received the data on the write cycle or returned data on a read cycle. |
| | I/O | If not used for MPI these pins are user-programmable I/O pins after configuration. ¹ |
| MPI_CLK | I | This is the PowerPC synchronous, positive-edge bus clock used for the MPI interface. It can be a source of the clock for the Embedded System Bus. If MPI is used this will be the AMBA bus clock. |
| | I/O | If not used for MPI these pins are user-programmable I/O pins after configuration. ¹ |
| MPI_TEA | O | A low on the MPI transfer error acknowledge indicates that the MPI detects a bus error on the internal system bus for the current transaction. |
| | I/O | If not used for MPI these pins are user-programmable I/O pins after configuration. ¹ |
| MPI_RTRY | O | This pin requests the MPC860 to relinquish the bus and retry the cycle. |
| | I/O | If not used for MPI these pins are user-programmable I/O pins after configuration. ¹ |
| D[0:31] | I/O | Selectable data bus width from 8, 16, 32-bit in MPI mode. Driven by the bus master in a write transaction and driven by MPI in a read transaction. |
| | I | D[7:0] receive configuration data during master parallel, peripheral, and slave parallel configuration modes when \overline{WR} is low and each pin has a pull-up enabled. During serial configuration modes, D0 is the DIN input. |
| | O | D[7:3] output internal status for asynchronous peripheral mode when \overline{RD} is low. |
| | I/O | After configuration, if MPI is not used, the pins are user-programmable I/O pins. ¹ |
| DP[0:3] | I/O | Selectable parity bus width in MPI mode from 1, 2, 4-bit, DP[0] for D[0:7], DP[1] for D[8:15], DP[2] for D[16:23], and DP[3] for D[24:31]. After configuration, if MPI is not used, the pins are user-programmable I/O pin. ¹ |
| DIN | I | During slave serial or master serial configuration modes, DIN accepts serial configuration data synchronous with CCLK. During parallel configuration modes, DIN is the D0 input. During configuration, a pull-up is enabled. |
| | I/O | After configuration, this pin is a user-programmable I/O pin. ¹ |
| DOUT | O | During configuration, DOUT is the serial data output that can drive the DIN of daisy-chained slave devices. Data out on DOUT changes on the rising edge of CCLK. |
| | I/O | After configuration, DOUT is a user-programmable I/O pin. ¹ |
| TESTCFG (ORSO82G5 only) | I | During configuration this pin should be held high, to allow configuration to occur. A pull up is enabled during configuration. |
| | I/O | After configuration, TESTCFG is a user programmable I/O pin. ¹ |

1. The FPGA States of Operation section in the ORCA Series 4 FPGAs data sheet contains more information on how to control these signals during start-up. The timing of DONE release is controlled by one set of bit stream options, and the timing of the simultaneous release of all other configuration pins (and the activation of all user I/Os) is controlled by a second set of options.

This section describes device I/O signals to/from the embedded core.

Table 48. FPSC Function Pin Descriptions

| Symbol | I/O | Description |
|---|-----|---|
| Common Signals for Both SERDES Block A and B | | |
| PASB_RESETN | I | Active low reset for the embedded core. ¹ |
| PASB_TRISTN | I | Active low 3-state for embedded core output buffers. ¹ |
| PASB_PDN | I | Active low power down of all SERDES blocks and associated I/Os. ¹ |
| PASB_TESTCLK | I | Clock input for BIST and loopback test (factory only). ¹ |
| PBIST_TEST_ENN | I | Selection of PASB_TESTCLK input for BIST test (factory only). ¹ |
| PLOOP_TEST_ENN | I | Digital only loopback from TX to RX (factory only). ¹ |
| PMP_TESTCLK | I | Clock input for microprocessor in test mode (factory only). ¹ |
| PMP_TESTCLK_ENN | I | Selection of PMP_TESTCLK in test mode (factory only). ¹ |
| PSYS_DOBISTN | I | Input to start BIST test (factory only). ¹ |
| PSYS_RSSIG_ALL | O | Output result of BIST test (factory only). |
| SERDES Block A and B Pins | | |
| REFCLKN_A | I | CML reference clock input—SERDES block A. |
| REFCLKP_A | I | CML reference clock input—SERDES block A. |
| REFCLKN_B | I | CML reference clock input—SERDES block B. |
| REFCLKP_B | I | CML reference clock input—SERDES block B. |
| REXT_A | — | Reference resistor—SERDES block A. |
| REXT_B | — | Reference resistor—SERDES block B. |
| REXTN_A | — | Reference resistor – SERDES block. A 3.32 K Ω \pm 1% resistor must be connected across REXT_B and REXTN_B. This resistor should handle a current of 300 μ A. |
| REXTN_B | — | Reference resistor—SERDES block B. A 3.32 K Ω \pm 1% resistor must be connected across REXT_B and REXTN_B. This register should handle a current of 300 μ A |
| HDINN_AA | I | High-speed CML receive data input—SERDES block A, channel A (not available in ORSO42G5). |
| HDINP_AA | I | High-speed CML receive data input—SERDES block A, channel A (not available in ORSO42G5). |
| HDINN_AB | I | High-speed CML receive data input—SERDES block A, channel B (not available in ORSO42G5). |
| HDINP_AB | I | High-speed CML receive data input—SERDES block A, channel B (not available in ORSO42G5). |
| HDINN_AC | I | High-speed CML receive data input—SERDES block A, channel C. |
| HDINP_AC | I | High-speed CML receive data input—SERDES block A, channel C. |
| HDINN_AD | I | High-speed CML receive data input—SERDES block A, channel D. |
| HDINP_AD | I | High-speed CML receive data input—SERDES block A, channel D. |
| HDINN_BA | I | High-speed CML receive data input—SERDES block B, channel A. |
| HDINP_BA | I | High-speed CML receive data input—SERDES block B, channel A (not available in ORSO42G5). |
| HDINN_BB | I | High-speed CML receive data input—SERDES block B, channel B (not available in ORSO42G5). |
| HDINP_BB | I | High-speed CML receive data input—SERDES block B, channel B (not available in ORSO42G5). |
| HDINN_BC | I | High-speed CML receive data input—SERDES block B, channel C (not available in ORSO42G5). |
| HDINP_BC | I | High-speed CML receive data input—SERDES block B, channel C. |
| HDINN_BD | I | High-speed CML receive data input—SERDES block B, channel D. |
| HDINP_BD | I | High-speed CML receive data input—SERDES block B, channel D. |
| SERDES Block A and B Pins | | |
| HDOUTN_AA | O | High-speed CML transmit data output—SERDES Block A, channel A (not available in ORSO42G5). |
| HDOUTP_AA | O | High-speed CML transmit data output—SERDES Block A, channel A (not available in ORSO42G5). |

Table 48. FPSC Function Pin Descriptions (Continued)

| Symbol | I/O | Description |
|-------------------------|-----|--|
| HDOUTN_AB | O | High-speed CML transmit data output—SERDES Block A, channel B (not available in ORSO42G5). |
| HDOUTP_AB | O | High-speed CML transmit data output—SERDES Block A, channel B (not available in ORSO42G5). |
| HDOUTN_AC | O | High-speed CML transmit data output—SERDES Block A, channel C. |
| HDOUTP_AC | O | High-speed CML transmit data output—SERDES Block A, channel C. |
| HDOUTN_AD | O | High-speed CML transmit data output—SERDES Block A, channel D. |
| HDOUTP_AD | O | High-speed CML transmit data output—SERDES Block A, channel D. |
| HDOUTN_BA | O | High-speed CML transmit data output—SERDES Block B, channel A (not available in ORSO42G5). |
| HDOUTP_BA | O | High-speed CML transmit data output—SERDES Block B, channel A (not available in ORSO42G5). |
| HDOUTN_BB | O | High-speed CML transmit data output—SERDES Block B, channel B (not available in ORSO42G5). |
| HDOUTP_BB | O | High-speed CML transmit data output—SERDES Block B, channel B (not available in ORSO42G5). |
| HDOUTN_BC | O | High-speed CML transmit data output—SERDES Block B, channel C. |
| HDOUTP_BC | O | High-speed CML transmit data output—SERDES Block B, channel C. |
| HDOUTN_BD | O | High-speed CML transmit data output—SERDES Block B, channel D. |
| HDOUTP_BD | O | High-speed CML transmit data output—SERDES Block B, channel D. |
| Power and Ground | | |
| VDDIB_AA | — | 1.8V/1.5V power supply for high-speed serial input buffers (ORSO82G5 only). |
| VDDIB_AB | — | 1.8V/1.5V power supply for high-speed serial input buffers (ORSO82G5 only). |
| VDDIB_AC | — | 1.8V/1.5V power supply for high-speed serial input buffers. |
| VDDIB_AD | — | 1.8V/1.5V power supply for high-speed serial input buffers. |
| VDDIB_BA | — | 1.8V/1.5V power supply for high-speed serial input buffers (ORSO82G5 only). |
| VDDIB_BB | — | 1.8V/1.5V power supply for high-speed serial input buffers (ORSO82G5 only). |
| VDDIB_BC | — | 1.8V/1.5V power supply for high-speed serial input buffers. |
| VDDIB_BD | — | 1.8V/1.5V power supply for high-speed serial input buffers. |
| VDDOB_AA | — | 1.8V/1.5V power supply for high-speed serial output buffers (ORSO82G5 only). |
| VDDOB_AB | — | 1.8V/1.5V power supply for high-speed serial output buffers (ORSO82G5 only). |
| VDDOB_AC | — | 1.8V/1.5V power supply for high-speed serial output buffers. |
| VDDOB_AD | — | 1.8V/1.5V power supply for high-speed serial output buffers. |
| VDDOB_BA | — | 1.8V/1.5V power supply for high-speed serial output buffers (ORSO82G5 only). |
| VDDOB_BB | — | 1.8V/1.5V power supply for high-speed serial output buffers (ORSO82G5 only). |
| VDDOB_BC | — | 1.8V/1.5V power supply for high-speed serial output buffers. |
| VDDOB_BD | — | 1.8V/1.5V power supply for high-speed serial output buffers. |
| VDDGB_A | — | 1.5V guard band power supply. |
| VDDGB_B | — | 1.5V guard band power supply. |
| VDD_ANA | — | 1.5V Power supplies for SERDES analog transmit and receive circuitry. |

1. Should be externally connected on board to 3.3V pull-up resistor.

Power Supplies

Power Supply Descriptions

Table 49 shows the ORSO42G5 and ORSO82G5 FPGAs and embedded core power supply groupings. VDD33 is a 3.3V positive power supply used for 3.3V configuration RAMs and internal FPGA PLLs. When using FPGA PLLs, this power supply should be well isolated from all other power supplies on the board for proper operation. The five VDDIO supplies are positive power supply used by the FPGA I/O banks. The 1.5 volt digital power supplies are used for the FPGA and the embedded core transmit and receive digital logic including the microprocessor logic. The 1.5 volt analog power supply is used for high-speed analog circuitry in the embedded core between the I/O buffers and the digital logic. The RX input buffer power supplies are used to power the input (receive) buffers. The TX output buffer supplies are used to power the output (transmit) buffers. The Rx and TX buffer power supplies can be independently set to 1.5V or 1.8V, depending on the end application. The guard band supplies are independent connection brought out to pins.

Table 49. Power Supplies

| FPGA Supplies | FPGA and Core Digital Supply 1.5V | Analog 1.5V | Tx Output Buffers 1.5V/1.8V (VDDOB) | Rx Input Buffers 1.5V/1.8V (VDDIB) | Guard Band 1.5V (VDDGB) |
|---------------|-----------------------------------|-------------|-------------------------------------|------------------------------------|-------------------------|
| VDD33 | VDD15 | VDD_ANA | VDDOB_AA | VDDIB_AA | VDDGB_A |
| VDDIO0 | — | | VDDOB_AB | VDDIB_AB | VDDGB_B |
| VDDIO1 | — | | VDDOB_AC | VDDIB_AC | — |
| VDDIO5 | — | | VDDOB_AD | VDDIB_AD | — |
| VDDIO6 | — | | VDDOB_BA | VDDIB_BA | — |
| VDDIO7 | — | | VDDOB_BB | VDDIB_BB | — |
| | — | | VDDOB_BC | VDDIB_BC | — |
| | — | | VDDOB_BD | VDDIB_BD | — |

Recommended Power Supply Connections

Ideally, a board should have the power supplies described below:

- VDD33 and VDDIO supplies for the FPGA Logic
- A single 1.5V source to supply power to FPGA and core digital logic.
- A dedicated 1.5V power supply for the analog power pins. This will allow the end user to minimize noise. The guard band pins can also be sourced from the analog power supplies.
- TX output buffer power. The power supplies to the TX output buffers should be isolated from the rest of the board power supplies. Special care must be taken to minimize noise when providing board level power to these output buffers. The power supply can be 1.5V or 1.8V depending on the end application.
- RX input buffer power. The power supplies to the Rx input buffers should be isolated from the rest of the board power supplies. Special care must be taken to minimize noise when providing board level power to these input buffers. The power supply can be 1.5V or 1.8V depending on the end application.

Recommended Power Supply Filtering Scheme

The board connections of the various SERDES VDD and VSS pins are critical to system performance. An example demonstration board schematic is available at www.latticesemi.com.

Power supply filtering is in the form of:

- A parallel bypass capacitor network consisting of 10 μ f, 0.1 μ f, and 1.0 μ f caps close to the power source.
- A parallel bypass capacitor network consisting of 0.01 μ f and 0.1 μ f close to the pin on the ORSO42G5 and ORSO82G5.

- Example connections are shown in Figure 52. The naming convention for the power supply sources shown in the figure are as follows:
 - Supply_1.5V Tx-Rx digital, auxiliary power pins
 - Supply_VDD_ANA Analog power pins
 - Supply_VDDIB Input Rx buffer power pins
 - Supply_VDDOB Output Tx buffer power pins

Figure 52. Power Supply Filtering

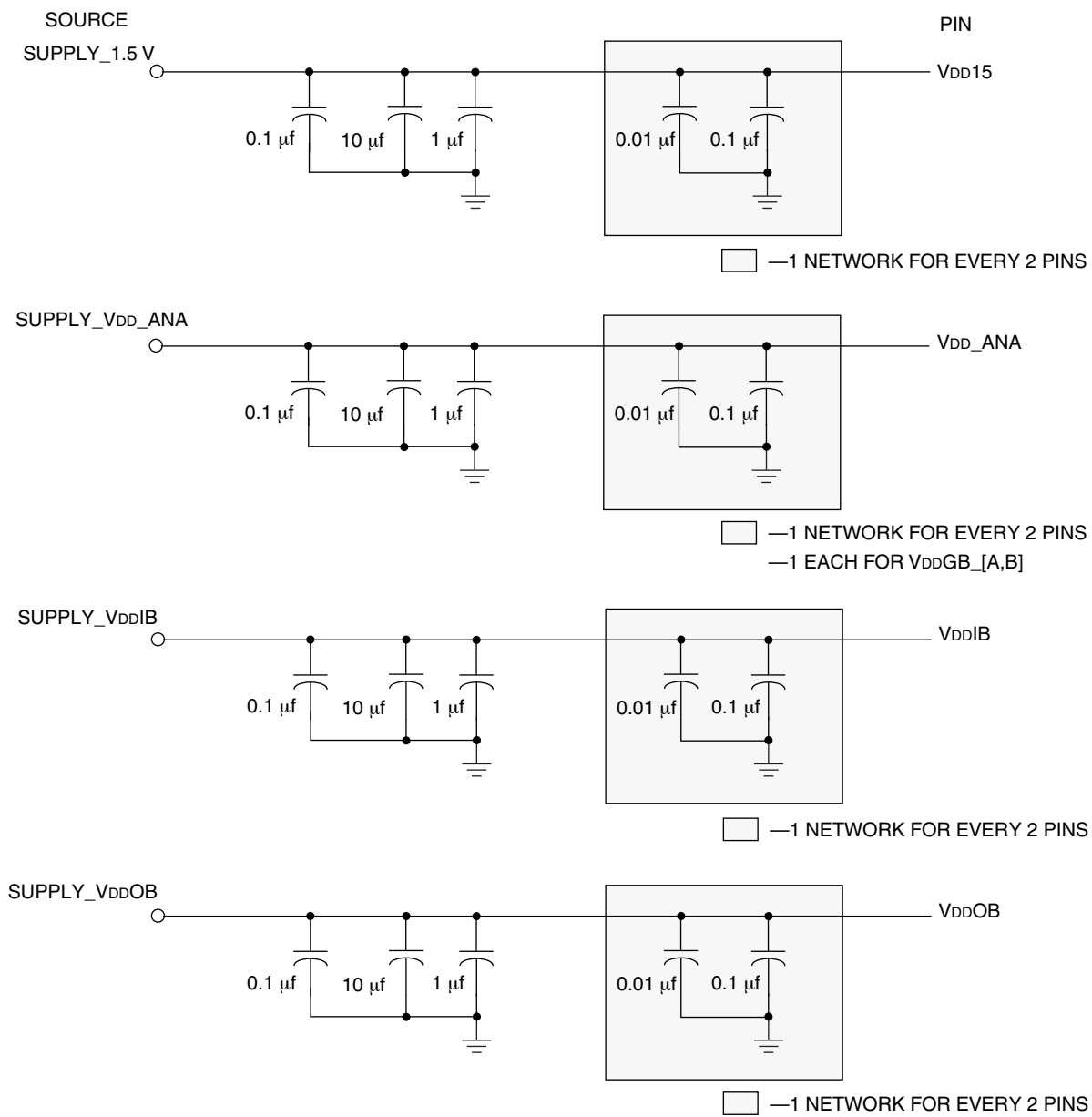

Package Information

Package Pinouts

Table 50 provides the number of user-programmable I/Os available for each available package.

Table 50. I/O Summary

| Device | ORSO42G5 | ORSO82G5 |
|---|----------|----------|
| User programmable I/O | 204 | 372 |
| Available programmable differential pair pins | 166 | 330 |
| FPGA configuration pins | 7 | 7 |
| FPGA dedicated function pins | 2 | 2 |
| Core function pins | 32 | 71 |
| VDD15 | 49 | 63 |
| VDD33 | 8 | 10 |
| VDDIO | 34 | 32 |
| VSS | 112 | 91 |
| VDDGB | 2 | 2 |
| VDDIB | 4 | 8 |
| VDDOB | 8 | 12 |
| VDD_ANA | 22 | 8 |
| Core LV_REF pins | 1 | 1 |
| No connect | 0 | 2 |
| Total package pins | 484 | 680 |

Table 51 provides the package pin and pin function for the ORSO42G5 and ORSO82G5 FPSC and packages. The bond pad name is identified in the PIO nomenclature used in the ispLEVER System software design editor. The Bank column provides information as to which output voltage level bank the given pin is in. The Group column provides information as to the group of pins the given pin is in. This is used to show which VREF pin is used to provide the reference voltage for single-ended limited-swing I/Os. If none of these buffer types (such as SSTL, GTL, HSTL) are used in a given group, then the VREF pin is available as an I/O pin.

When the number of FPGA bond pads exceeds the number of package pins, bond pads are unused. When the number of package pins exceeds the number of bond pads, package pins are left unconnected (no connects). When a package pin is to be left as a no connect for a specific die, it is indicated as a note in the device column for the FPGA. The tables provide no information on unused pads.

The differential pairs within each bank are physically arranged so that the ball locations for the pair are adjacent in either the horizontal, vertical or diagonal directions.

VREF pins, shown in the Pin Description columns in Table 51 are associated to the bank and group (e.g., VREF_TL_01 is the VREF for group one of the Top Left (TL) bank).

Table 51. ORSO42G5 484-pin PBGM Pinout

| 484-PBGM | VDDIO Bank | VREF Group | I/O | Pin Description | Additional Function | 484-PBGM |
|----------|------------|------------|-------|-----------------|---------------------|----------|
| E4 | - | - | O | PRD_DATA | RD_DATA/TDO | - |
| C20 | - | - | VDD15 | VDD15 | - | - |
| D3 | - | - | I | PRESET_N | RESET_N | - |
| F5 | - | - | I | PRD_CFG_N | RD_CFG_N | - |
| F4 | - | - | I | PPRGRM_N | PRGRM_N | - |
| C2 | 0 (TL) | 7 | IO | PL2D | PLL_CK0C/HPPLL | L1C |

Table 51. ORSO42G5 484-pin PBGAM Pinout (Continued)

| 484-PBGAM | VDDIO Bank | VREF Group | I/O | Pin Description | Additional Function | 484-PBGAM |
|-----------|------------|------------|--------|-----------------|---------------------|-----------|
| C1 | 0 (TL) | 7 | IO | PL2C | PLL_CK0T/HPPLL | L1T |
| F3 | 0 (TL) | 7 | IO | PL3C | VREF_0_07 | - |
| A1 | - | - | VSS | VSS | - | - |
| D2 | 0 (TL) | 7 | IO | PL4D | D5 | L2C |
| D1 | 0 (TL) | 7 | IO | PL4C | D6 | L2T |
| E7 | 0 (TL) | - | VDDIO0 | VDDIO0 | - | - |
| E2 | 0 (TL) | 8 | IO | PL5D | HDC | L3C |
| E1 | 0 (TL) | 8 | IO | PL5C | LDC_N | L3T |
| G3 | 0 (TL) | 8 | IO | PL5A | - | - |
| G4 | 0 (TL) | 9 | IO | PL6C | D7 | - |
| F2 | 0 (TL) | 9 | IO | PL7D | VREF_0_09 | L4C |
| F1 | 0 (TL) | 9 | IO | PL7C | A17/PPC_A31 | L4T |
| G2 | 0 (TL) | 9 | IO | PL8D | CS0_N | L5C |
| G1 | 0 (TL) | 9 | IO | PL8C | CS1 | L5T |
| E8 | 0 (TL) | - | VDDIO0 | VDDIO0 | - | - |
| A2 | - | - | VSS | VSS | - | - |
| H1 | 0 (TL) | 10 | IO | PL10D | INIT_N | L6C |
| H2 | 0 (TL) | 10 | IO | PL10C | DOUT | L6T |
| E5 | - | - | VDD15 | VDD15 | - | - |
| H4 | 0 (TL) | 10 | IO | PL11D | VREF_0_10 | - |
| H3 | 0 (TL) | 10 | IO | PL11C | A16/PPC_A30 | - |
| J1 | 7 (CL) | 1 | IO | PL12D | A15/PPC_A29 | L7C |
| J2 | 7 (CL) | 1 | IO | PL12C | A14/PPC_A28 | L7T |
| J4 | 7 (CL) | 1 | IO | PL13C | D4 | - |
| G7 | - | - | VSS | VSS | - | - |
| J3 | 7 (CL) | 2 | IO | PL14D | RDY/BUSY_N/RCLK | - |
| K6 | 7 (CL) | - | VDDIO7 | VDDIO7 | - | - |
| K1 | 7 (CL) | 2 | IO | PL15D | A13/PPC_A27 | L8C |
| K2 | 7 (CL) | 2 | IO | PL15C | A12/PPC_A26 | L8T |
| K3 | 7 (CL) | 3 | IO | PL16C | - | - |
| K4 | 7 (CL) | 3 | IO | PL17D | A11/PPC_A25 | - |
| G8 | - | - | VSS | VSS | - | - |
| F8 | - | - | VDD15 | VDD15 | - | - |
| K5 | 7 (CL) | 4 | IO | PL19D | RD_N/MPI_STRB_N | - |
| L1 | 7 (CL) | 4 | IO | PL20D | PLCK0C | L9C |
| L2 | 7 (CL) | 4 | IO | PL20C | PLCK0T | L9T |
| L6 | 7 (CL) | - | VDDIO7 | VDDIO7 | - | - |
| F9 | - | - | VDD15 | VDD15 | - | - |
| G9 | - | - | VSS | VSS | - | - |
| L3 | 7 (CL) | 5 | IO | PL21D | A10/PPC_A24 | L10C |
| L4 | 7 (CL) | 5 | IO | PL21C | A9/PPC_A23 | L10T |
| L5 | 7 (CL) | 5 | IO | PL22D | A8/PPC_A22 | - |
| F10 | - | - | VDD15 | VDD15 | - | - |
| G10 | - | - | VSS | VSS | - | - |

Table 51. ORSO42G5 484-pin PBGAM Pinout (Continued)

| 484-PBGAM | VDDIO Bank | VREF Group | I/O | Pin Description | Additional Function | 484-PBGAM |
|-----------|------------|------------|--------|-----------------|---------------------|-----------|
| M3 | 7 (CL) | 6 | IO | PL24D | PLCK1C | L11C |
| M4 | 7 (CL) | 6 | IO | PL24C | PLCK1T | L11T |
| N4 | 7 (CL) | 6 | IO | PL25C | A7/PPC_A21 | - |
| M2 | 7 (CL) | 6 | IO | PL26D | A6/PPC_A20 | L12C |
| M1 | 7 (CL) | 6 | IO | PL26C | A5/PPC_A19 | L12T |
| N3 | 7 (CL) | 7 | IO | PL27D | WR_N/MPI_RW | - |
| F11 | - | - | VDD15 | VDD15 | - | - |
| N5 | 7 (CL) | 8 | IO | PL28D | A4/PPC_A18 | - |
| M5 | 7 (CL) | - | VDDIO7 | VDDIO7 | - | - |
| N2 | 7 (CL) | 8 | IO | PL29D | A3/PPC_A17 | L13C |
| N1 | 7 (CL) | 8 | IO | PL29C | A2/PPC_A16 | L13T |
| G11 | - | - | VSS | VSS | - | - |
| P2 | 7 (CL) | 8 | IO | PL30D | A1/PPC_A15 | L14C |
| P1 | 7 (CL) | 8 | IO | PL30C | A0/PPC_A14 | L14T |
| F12 | - | - | VDD15 | VDD15 | - | - |
| P3 | 7 (CL) | 8 | IO | PL31D | DP0 | L15C |
| P4 | 7 (CL) | 8 | IO | PL31C | DP1 | L15T |
| R4 | 6 (BL) | 1 | IO | PL32D | D8 | L16C |
| R3 | 6 (BL) | 1 | IO | PL32C | VREF_6_01 | L16T |
| R2 | 6 (BL) | 1 | IO | PL33D | D9 | L17C |
| R1 | 6 (BL) | 1 | IO | PL33C | D10 | L17T |
| G12 | - | - | VSS | VSS | - | - |
| T3 | 6 (BL) | 2 | IO | PL34D | - | - |
| P5 | 6 (BL) | - | VDDIO6 | VDDIO6 | - | - |
| T2 | 6 (BL) | 2 | IO | PL34B | - | L18C |
| T1 | 6 (BL) | 2 | IO | PL34A | - | L18T |
| U1 | 6 (BL) | 3 | IO | PL35B | D11 | L19C |
| U2 | 6 (BL) | 3 | IO | PL35A | D12 | L19T |
| R5 | 6 (BL) | - | VDDIO6 | VDDIO6 | - | - |
| V1 | 6 (BL) | 3 | IO | PL36B | VREF_6_03 | L20C |
| V2 | 6 (BL) | 3 | IO | PL36A | D13 | L20T |
| G13 | - | - | VSS | VSS | - | - |
| W2 | 6 (BL) | 4 | IO | PL37B | - | L21C |
| W1 | 6 (BL) | 4 | IO | PL37A | VREF_6_04 | L21T |
| Y1 | 6 (BL) | 4 | IO | PL39D | PLL_CK7C/HPPLL | L22C |
| Y2 | 6 (BL) | 4 | IO | PL39C | PLL_CK7T/HPPLL | L22T |
| U3 | - | - | I | PTEMP | PTEMP | - |
| F13 | - | - | VDD15 | VDD15 | - | - |
| V4 | - | - | IO | LVDS_R | LVDS_R | - |
| V3 | - | - | VDD33 | VDD33 | - | - |
| F17 | - | - | VDD15 | VDD15 | - | - |
| W3 | 6 (BL) | 5 | IO | PB2A | DP2 | - |
| AA2 | 6 (BL) | 5 | IO | PB2C | PLL_CK6T/PPLL | L23T |
| AB2 | 6 (BL) | 5 | IO | PB2D | PLL_CK6C/PPLL | L23C |

Table 51. ORSO42G5 484-pin PBGAM Pinout (Continued)

| 484-PBGAM | VDDIO Bank | VREF Group | I/O | Pin Description | Additional Function | 484-PBGAM |
|-----------|------------|------------|--------|-----------------|---------------------|-----------|
| AA3 | 6 (BL) | 5 | IO | PB4A | VREF_6_05 | L24T |
| AB3 | 6 (BL) | 5 | IO | PB4B | DP3 | L24C |
| T5 | 6 (BL) | - | VDDIO6 | VDDIO6 | - | - |
| H7 | - | - | VSS | VSS | - | - |
| Y4 | 6 (BL) | 6 | IO | PB5C | VREF_6_06 | L25T |
| W4 | 6 (BL) | 6 | IO | PB5D | D14 | L25C |
| T8 | 6 (BL) | - | VDDIO6 | VDDIO6 | - | - |
| AA4 | 6 (BL) | 7 | IO | PB6C | D15 | L26T |
| AB4 | 6 (BL) | 7 | IO | PB6D | D16 | L26C |
| H8 | - | - | VSS | VSS | - | - |
| W5 | 6 (BL) | 7 | IO | PB7C | D17 | L27T |
| Y5 | 6 (BL) | 7 | IO | PB7D | D18 | L27C |
| T9 | 6 (BL) | - | VDDIO6 | VDDIO6 | - | - |
| AA5 | 6 (BL) | 7 | IO | PB8C | VREF_6_07 | L28T |
| AB5 | 6 (BL) | 7 | IO | PB8D | D19 | L28C |
| H9 | - | - | VSS | VSS | - | - |
| V6 | 6 (BL) | 8 | IO | PB9C | D20 | - |
| G6 | - | - | VDD15 | VDD15 | - | - |
| W6 | 6 (BL) | 8 | IO | PB10C | VREF_6_08 | L29T |
| Y6 | 6 (BL) | 8 | IO | PB10D | D22 | L29C |
| H10 | - | - | VSS | VSS | - | - |
| AA6 | 6 (BL) | 9 | IO | PB11C | D23 | L30T |
| AB6 | 6 (BL) | 9 | IO | PB11D | D24 | L30C |
| U6 | 6 (BL) | - | VDDIO6 | VDDIO6 | - | - |
| W7 | 6 (BL) | 9 | IO | PB12C | VREF_6_09 | L31T |
| Y7 | 6 (BL) | 9 | IO | PB12D | D25 | L31C |
| H11 | - | - | VSS | VSS | - | - |
| V7 | 6 (BL) | 10 | IO | PB14A | - | - |
| U7 | 6 (BL) | - | VDDIO6 | VDDIO6 | - | - |
| AA7 | 6 (BL) | 10 | IO | PB14C | VREF_6_10 | L32T |
| AB7 | 6 (BL) | 10 | IO | PB14D | D28 | L32C |
| V8 | 6 (BL) | 11 | IO | PB15A | - | - |
| H12 | - | - | VSS | VSS | - | - |
| W8 | 6 (BL) | 11 | IO | PB15C | D29 | L33T |
| Y8 | 6 (BL) | 11 | IO | PB15D | D30 | L33C |
| U8 | 6 (BL) | 11 | IO | PB16A | - | - |
| AA8 | 6 (BL) | 11 | IO | PB16C | VREF_6_11 | L34T |
| AB8 | 6 (BL) | 11 | IO | PB16D | D31 | L34C |
| V9 | 5 (BC) | 1 | IO | PB17A | - | - |
| W9 | 5 (BC) | 1 | IO | PB17C | - | L35T |
| Y9 | 5 (BC) | 1 | IO | PB17D | - | L35C |
| U9 | 5 (BC) | 1 | IO | PB18A | - | - |
| AA9 | 5 (BC) | 1 | IO | PB18C | VREF_5_01 | L36T |
| AB9 | 5 (BC) | 1 | IO | PB18D | - | L36C |

Table 51. ORSO42G5 484-pin PBGAM Pinout (Continued)

| 484-PBGAM | VDDIO Bank | VREF Group | I/O | Pin Description | Additional Function | 484-PBGAM |
|-----------|------------|------------|--------|-----------------|---------------------|-----------|
| G16 | - | - | VDD15 | VDD15 | - | - |
| H13 | - | - | VSS | VSS | - | - |
| AB10 | 5 (BC) | 2 | IO | PB19A | - | L37T |
| AA10 | 5 (BC) | 2 | IO | PB19B | - | L37C |
| W10 | 5 (BC) | 2 | IO | PB19C | PBCK0T | L38T |
| Y10 | 5 (BC) | 2 | IO | PB19D | PBCK0C | L38C |
| V10 | 5 (BC) | 2 | IO | PB20A | - | - |
| U13 | 5 (BC) | - | VDDIO5 | VDDIO5 | - | - |
| AB11 | 5 (BC) | 2 | IO | PB20C | VREF_5_02 | L39T |
| AA11 | 5 (BC) | 2 | IO | PB20D | - | L39C |
| U10 | 5 (BC) | 2 | IO | PB21A | - | - |
| H6 | - | - | VDD15 | VDD15 | - | - |
| Y11 | 5 (BC) | 3 | IO | PB21C | - | L40T |
| W11 | 5 (BC) | 3 | IO | PB21D | VREF_5_03 | L40C |
| U11 | 5 (BC) | 3 | IO | PB22A | - | - |
| J7 | - | - | VSS | VSS | - | - |
| AB12 | 5 (BC) | 3 | IO | PB22C | - | L41T |
| AA12 | 5 (BC) | 3 | IO | PB22D | - | L41C |
| U12 | 5 (BC) | 3 | IO | PB23A | - | - |
| Y12 | 5 (BC) | 3 | IO | PB23C | PBCK1T | L42T |
| W12 | 5 (BC) | 3 | IO | PB23D | PBCK1C | L42C |
| V11 | 5 (BC) | 3 | IO | PB24A | - | - |
| J8 | - | - | VSS | VSS | - | - |
| AB13 | 5 (BC) | 4 | IO | PB24C | - | L43T |
| AA13 | 5 (BC) | 4 | IO | PB24D | - | L43C |
| V12 | 5 (BC) | 4 | IO | PB25A | - | - |
| U14 | 5 (BC) | - | VDDIO5 | VDDIO5 | - | - |
| AB14 | 5 (BC) | 4 | IO | PB25C | - | L44T |
| AA14 | 5 (BC) | 4 | IO | PB25D | VREF_5_04 | L44C |
| J9 | - | - | VSS | VSS | - | - |
| Y13 | 5 (BC) | 5 | IO | PB26C | - | L45T |
| W13 | 5 (BC) | 5 | IO | PB26D | VREF_5_05 | L45C |
| U15 | 5 (BC) | - | VDDIO5 | VDDIO5 | - | - |
| AB15 | 5 (BC) | 5 | IO | PB27C | - | L46T |
| AA15 | 5 (BC) | 5 | IO | PB27D | - | L46C |
| AB16 | 5 (BC) | 6 | IO | PB28C | - | L47T |
| AA16 | 5 (BC) | 6 | IO | PB28D | VREF_5_06 | L47C |
| H14 | - | - | VDD15 | VDD15 | - | - |
| Y14 | 5 (BC) | 6 | IO | PB29C | - | L48T |
| W14 | 5 (BC) | 6 | IO | PB29D | - | L48C |
| J10 | - | - | VSS | VSS | - | - |
| AB17 | 5 (BC) | 7 | IO | PB30C | - | L49T |
| AA17 | 5 (BC) | 7 | IO | PB30D | - | L49C |
| U16 | 5 (BC) | - | VDDIO5 | VDDIO5 | - | - |

Table 51. ORSO42G5 484-pin PBGAM Pinout (Continued)

| 484-PBGAM | VDDIO Bank | VREF Group | I/O | Pin Description | Additional Function | 484-PBGAM |
|-----------|------------|------------|---------|-----------------|---------------------|-----------|
| Y15 | 5 (BC) | 7 | IO | PB31C | VREF_5_07 | L50T |
| W15 | 5 (BC) | 7 | IO | PB31D | - | L50C |
| V13 | 5 (BC) | - | VDDIO5 | VDDIO5 | - | - |
| AB18 | 5 (BC) | 8 | IO | PB33C | - | L51T |
| AA18 | 5 (BC) | 8 | IO | PB33D | VREF_5_08 | L51C |
| J11 | - | - | VSS | VSS | - | - |
| V14 | 5 (BC) | 8 | IO | PB34D | - | - |
| V16 | 5 (BC) | 9 | IO | PB35B | - | - |
| Y16 | 5 (BC) | 9 | IO | PB36C | - | L52T |
| W16 | 5 (BC) | 9 | IO | PB36D | - | L52C |
| V15 | - | - | VDD33 | VDD33 | - | - |
| J12 | - | - | VSS | VSS | - | - |
| H15 | - | - | VDD15 | VDD15 | - | - |
| J13 | - | - | VSS | VSS | - | - |
| J6 | - | - | VDD15 | VDD15 | - | - |
| J14 | - | - | VSS | VSS | - | - |
| Y17 | - | - | VDD33 | VDD33 | - | - |
| K8 | - | - | VSS | VSS | - | - |
| J15 | - | - | VDD15 | VDD15 | - | - |
| K7 | - | - | VDD15 | VDD15 | - | - |
| Y18 | - | - | VDD33 | VDD33 | - | - |
| K9 | - | - | VSS | VSS | - | - |
| W21 | - | - | VSS | VSS | - | - |
| W22 | - | - | VDDGB_B | VDDGB_B | - | - |
| F18 | - | - | VDD_ANA | VDD_ANA | - | - |
| V21 | - | - | O | REXT_B | - | - |
| V22 | - | - | O | REXTN_B | - | - |
| U21 | - | - | I | REFCLKN_B | - | HSN_1 |
| U22 | - | - | I | REFCLKP_B | - | HSP_1 |
| E20 | - | - | VSS | VSS | - | - |
| G17 | - | - | VDD_ANA | VDD_ANA | - | - |
| G18 | - | - | VDD_ANA | VDD_ANA | - | - |
| J16 | - | - | VDD_ANA | VDD_ANA | - | - |
| J17 | - | - | VDD_ANA | VDD_ANA | - | - |
| T20 | - | - | VDDIB | VDDIB_BC | - | - |
| J18 | - | - | VDD_ANA | VDD_ANA | - | - |
| T21 | - | - | I | HDINN_BC | - | HSN_2 |
| F19 | - | - | VSS | VSS | - | - |
| T22 | - | - | I | HDINP_BC | - | HSP_2 |
| J19 | - | - | VDD_ANA | VDD_ANA | - | - |
| F20 | - | - | VSS | VSS | - | - |
| K16 | - | - | VDD_ANA | VDD_ANA | - | - |
| R20 | - | - | VDDOB | VDDOB_BC | - | - |
| R21 | - | - | O | HDOUTN_BC | - | HSN_3 |

Table 51. ORSO42G5 484-pin PBGAM Pinout (Continued)

| 484-PBGAM | VDDIO Bank | VREF Group | I/O | Pin Description | Additional Function | 484-PBGAM |
|-----------|------------|------------|---------|-----------------|---------------------|-----------|
| G19 | - | - | VSS | VSS | - | - |
| R22 | - | - | O | HDOUTP_BC | - | HSP_3 |
| P21 | - | - | VDDOB | VDDOB_BC | - | - |
| H16 | - | - | VSS | VSS | - | - |
| P22 | - | - | VDDIB | VDDIB_BD | - | - |
| K17 | - | - | VDD_ANA | VDD_ANA | - | - |
| N22 | - | - | I | HDINN_BD | - | HSN_4 |
| H17 | - | - | VSS | VSS | - | - |
| N21 | - | - | I | HDINP_BD | - | HSP_4 |
| K18 | - | - | VDD_ANA | VDD_ANA | - | - |
| H18 | - | - | VSS | VSS | - | - |
| K19 | - | - | VDD_ANA | VDD_ANA | - | - |
| P20 | - | - | VDDOB | VDDOB_BD | - | - |
| M22 | - | - | O | HDOUTN_BD | - | HSN_5 |
| H19 | - | - | VSS | VSS | - | - |
| M21 | - | - | O | HDOUTP_BD | - | HSP_5 |
| N20 | - | - | VDDOB | VDDOB_BD | - | - |
| L16 | - | - | VSS | VSS | - | - |
| L17 | - | - | VSS | VSS | - | - |
| M20 | - | - | VDDOB | VDDOB_AD | - | - |
| L22 | - | - | O | HDOUTP_AD | - | HSP_6 |
| L18 | - | - | VSS | VSS | - | - |
| L21 | - | - | O | HDOUTN_AD | - | HSN_6 |
| L20 | - | - | VDDOB | VDDOB_AD | - | - |
| N16 | - | - | VDD_ANA | VDD_ANA | - | - |
| L19 | - | - | VSS | VSS | - | - |
| N17 | - | - | VDD_ANA | VDD_ANA | - | - |
| K22 | - | - | I | HDINP_AD | - | HSP_7 |
| M16 | - | - | VSS | VSS | - | - |
| K21 | - | - | I | HDINN_AD | - | HSN_7 |
| N18 | - | - | VDD_ANA | VDD_ANA | - | - |
| K20 | - | - | VDDIB | VDDIB_AD | - | - |
| M17 | - | - | VSS | VSS | - | - |
| J20 | - | - | VDDOB | VDDOB_AC | - | - |
| J21 | - | - | O | HDOUTP_AC | - | HSP_8 |
| M18 | - | - | VSS | VSS | - | - |
| J22 | - | - | O | HDOUTN_AC | - | HSN_8 |
| H20 | - | - | VDDOB | VDDOB_AC | - | - |
| N19 | - | - | VDD_ANA | VDD_ANA | - | - |
| M19 | - | - | VSS | VSS | - | - |
| P16 | - | - | VDD_ANA | VDD_ANA | - | - |
| H21 | - | - | I | HDINP_AC | - | HSP_9 |
| R16 | - | - | VSS | VSS | - | - |
| H22 | - | - | I | HDINN_AC | - | HSN_9 |

Table 51. ORSO42G5 484-pin PBGAM Pinout (Continued)

| 484-PBGAM | VDDIO Bank | VREF Group | I/O | Pin Description | Additional Function | 484-PBGAM |
|-----------|------------|------------|---------|-----------------|---------------------|-----------|
| P17 | - | - | VDD_ANA | VDD_ANA | - | - |
| G20 | - | - | VDDIB | VDDIB_AC | - | - |
| P18 | - | - | VDD_ANA | VDD_ANA | - | - |
| P19 | - | - | VDD_ANA | VDD_ANA | - | - |
| T17 | - | - | VDD_ANA | VDD_ANA | - | - |
| T18 | - | - | VDD_ANA | VDD_ANA | - | - |
| R17 | - | - | VSS | VSS | - | - |
| G21 | - | - | I | REFCLKP_A | - | HSP_10 |
| G22 | - | - | I | REFCLKN_A | - | HSN_10 |
| F21 | - | - | O | REXTN_A | - | - |
| F22 | - | - | O | REXT_A | - | - |
| U18 | - | - | VDD_ANA | VDD_ANA | - | - |
| E21 | - | - | VDDGB_A | VDDGB_A | - | - |
| E22 | - | - | VSS | VSS | - | - |
| D21 | - | - | O | PSYS_RSSIG_ALL | - | - |
| D22 | - | - | I | PSYS_DOBISTN | - | - |
| D20 | - | - | VDD33 | VDD33 | - | - |
| K15 | - | - | VDD15 | VDD15 | - | - |
| K10 | - | - | VSS | VSS | - | - |
| L7 | - | - | VDD15 | VDD15 | - | - |
| D19 | - | - | I | PBIST_TEST_ENN | - | - |
| D18 | - | - | I | PLOOP_TEST_ENN | - | - |
| L15 | - | - | VDD15 | VDD15 | - | - |
| E17 | - | - | I | PASB_PDN | - | - |
| K11 | - | - | VSS | VSS | - | - |
| D17 | - | - | VDD33 | VDD33 | - | - |
| M7 | - | - | VDD15 | VDD15 | - | - |
| C21 | - | - | I | PASB_RESETN | - | - |
| C22 | - | - | I | PASB_TRISTN | - | - |
| K12 | - | - | VSS | VSS | - | - |
| E16 | - | - | I | PASB_TESTCLK | - | - |
| M15 | - | - | VDD15 | VDD15 | - | - |
| C17 | - | - | VDD33 | VDD33 | - | - |
| D16 | 1 (TC) | 7 | IO | PT36D | - | - |
| C16 | 1 (TC) | 7 | IO | PT36B | - | - |
| F14 | 1 (TC) | 7 | IO | PT35D | - | - |
| F15 | 1 (TC) | 7 | IO | PT35B | - | - |
| E14 | 1 (TC) | 7 | IO | PT34D | VREF_1_07 | - |
| E15 | 1 (TC) | 8 | IO | PT34B | - | - |
| D15 | 1 (TC) | 8 | IO | PT33D | - | L53C |
| C15 | 1 (TC) | 8 | IO | PT33C | VREF_1_08 | L53T |
| E12 | 1 (TC) | - | VDDIO1 | VDDIO1 | - | - |
| C18 | 1 (TC) | 8 | IO | PT32D | - | L54C |
| C19 | 1 (TC) | 8 | IO | PT32C | - | L54T |

Table 51. ORSO42G5 484-pin PBGAM Pinout (Continued)

| 484-PBGAM | VDDIO Bank | VREF Group | I/O | Pin Description | Additional Function | 484-PBGAM |
|-----------|------------|------------|--------|-----------------|---------------------|-----------|
| K13 | - | - | VSS | VSS | - | - |
| B21 | 1 (TC) | 9 | IO | PT31D | - | L55C |
| A21 | 1 (TC) | 9 | IO | PT31C | VREF_1_09 | L55T |
| E13 | 1 (TC) | - | VDDIO1 | VDDIO1 | - | - |
| D14 | 1 (TC) | 9 | IO | PT30D | - | L56C |
| C14 | 1 (TC) | 9 | IO | PT30C | - | L56T |
| K14 | - | - | VSS | VSS | - | - |
| B20 | 1 (TC) | 9 | IO | PT29D | - | L57C |
| A20 | 1 (TC) | 9 | IO | PT29C | - | L57T |
| N7 | - | - | VDD15 | VDD15 | - | - |
| B19 | 1 (TC) | 1 | IO | PT28D | - | L58C |
| A19 | 1 (TC) | 1 | IO | PT28C | - | L58T |
| L8 | - | - | VSS | VSS | - | - |
| D13 | 1 (TC) | 1 | IO | PT27D | VREF_1_01 | L59C |
| C13 | 1 (TC) | 1 | IO | PT27C | - | L59T |
| E18 | 1 (TC) | - | VDDIO1 | VDDIO1 | - | - |
| A18 | 1 (TC) | 1 | IO | PT27B | - | L60C |
| B18 | 1 (TC) | 1 | IO | PT27A | - | L60T |
| A17 | 1 (TC) | 2 | IO | PT26D | - | L61C |
| B17 | 1 (TC) | 2 | IO | PT26C | VREF_1_02 | L61T |
| L9 | - | - | VSS | VSS | - | - |
| D12 | 1 (TC) | 2 | IO | PT25D | - | L62C |
| C12 | 1 (TC) | 2 | IO | PT25C | - | L62T |
| E19 | 1 (TC) | - | VDDIO1 | VDDIO1 | - | - |
| A16 | 1 (TC) | 3 | IO | PT24D | - | L63C |
| B16 | 1 (TC) | 3 | IO | PT24C | VREF_1_03 | L63T |
| A15 | 1 (TC) | 3 | IO | PT23D | - | L64C |
| B15 | 1 (TC) | 3 | IO | PT23C | - | L64T |
| F16 | 1 (TC) | - | VDDIO1 | VDDIO1 | - | - |
| E11 | 1 (TC) | 3 | IO | PT22D | - | - |
| L10 | - | - | VSS | VSS | - | - |
| D11 | 1 (TC) | 4 | IO | PT21D | - | L65C |
| C11 | 1 (TC) | 4 | IO | PT21C | - | L65T |
| A14 | 1 (TC) | 4 | IO | PT20D | - | L66C |
| B14 | 1 (TC) | 4 | IO | PT20C | - | L66T |
| A13 | 1 (TC) | 4 | IO | PT19D | - | L67C |
| B13 | 1 (TC) | 4 | IO | PT19C | VREF_1_04 | L67T |
| G14 | 1 (TC) | - | VDDIO1 | VDDIO1 | - | - |
| L11 | - | - | VSS | VSS | - | - |
| N15 | - | - | VDD15 | VDD15 | - | - |
| D10 | 1 (TC) | 5 | IO | PT18D | PTCK1C | L68C |
| C10 | 1 (TC) | 5 | IO | PT18C | PTCK1T | L68T |
| A12 | 1 (TC) | 5 | IO | PT17D | PTCK0C | L69C |
| B12 | 1 (TC) | 5 | IO | PT17C | PTCK0T | L69T |

Table 51. ORSO42G5 484-pin PBGM Pinout (Continued)

| 484-PBGM | VDDIO Bank | VREF Group | I/O | Pin Description | Additional Function | 484-PBGM |
|----------|------------|------------|--------|-----------------|---------------------|----------|
| P6 | - | - | VDD15 | VDD15 | - | - |
| A11 | 1 (TC) | 5 | IO | PT16D | VREF_1_05 | L70C |
| B11 | 1 (TC) | 5 | IO | PT16C | - | L70T |
| L12 | - | - | VSS | VSS | - | - |
| D9 | 1 (TC) | 6 | IO | PT15D | - | L71C |
| C9 | 1 (TC) | 6 | IO | PT15C | - | L71T |
| G15 | 1 (TC) | - | VDDIO1 | VDDIO1 | - | - |
| B10 | 1 (TC) | 6 | IO | PT14D | - | L72C |
| A10 | 1 (TC) | 6 | IO | PT14C | VREF_1_06 | L72T |
| B9 | 0 (TL) | 1 | IO | PT13D | MPI_RTRY_N | L73C |
| A9 | 0 (TL) | 1 | IO | PT13C | MPI_ACK_N | L73T |
| D8 | 0 (TL) | 1 | IO | PT12D | M0 | L74C |
| C8 | 0 (TL) | 1 | IO | PT12C | M1 | L74T |
| A22 | - | - | VSS | VSS | - | - |
| B8 | 0 (TL) | 2 | IO | PT12B | MPI_CLK | L75C |
| A8 | 0 (TL) | 2 | IO | PT12A | A21/MPI_BURST_N | L75T |
| C7 | 0 (TL) | 2 | IO | PT11D | M2 | L76C |
| D7 | 0 (TL) | 2 | IO | PT11C | M3 | L76T |
| E9 | 0 (TL) | - | VDDIO0 | VDDIO0 | - | - |
| E6 | 0 (TL) | 2 | IO | PT11A | MPI_TEA_N | - |
| F6 | - | - | VDD15 | VDD15 | - | - |
| B7 | 0 (TL) | 3 | IO | PT9D | VREF_0_03 | L77C |
| A7 | 0 (TL) | 3 | IO | PT9C | - | L77T |
| A6 | 0 (TL) | 3 | IO | PT8D | D0 | L78C |
| B6 | 0 (TL) | 3 | IO | PT8C | TMS | L78T |
| C6 | 0 (TL) | 4 | IO | PT7D | A20/MPI_BDIP_N | L79C |
| D6 | 0 (TL) | 4 | IO | PT7C | A19/MPI_TSZ1 | L79T |
| B1 | - | - | VSS | VSS | - | - |
| A5 | 0 (TL) | 4 | IO | PT6D | A18/MPI_TSZ0 | L80C |
| B5 | 0 (TL) | 4 | IO | PT6C | D3 | L80T |
| C5 | 0 (TL) | 5 | IO | PT5D | D1 | L81C |
| D5 | 0 (TL) | 5 | IO | PT5C | D2 | L81T |
| B2 | - | - | VSS | VSS | - | - |
| A4 | 0 (TL) | 5 | IO | PT4D | TDI | L82C |
| B4 | 0 (TL) | 5 | IO | PT4C | TCK | L82T |
| E10 | 0 (TL) | - | VDDIO0 | VDDIO0 | - | - |
| B22 | - | - | VSS | VSS | - | - |
| C4 | 0 (TL) | 6 | IO | PT2D | PLL_CK1C/PPLL | L83C |
| D4 | 0 (TL) | 6 | IO | PT2C | PLL_CK1T/PPLL | L83T |
| A3 | - | - | O | PCFG_MPI_IRQ | CFG_IRQ_N/MPI_IRQ_N | - |
| B3 | - | - | IO | PCCLK | CCLK | - |
| F7 | - | - | VDD15 | VDD15 | - | - |
| C3 | - | - | IO | PDONE | DONE | - |
| E3 | - | - | VDD33 | VDD33 | - | - |

Table 51. ORSO42G5 484-pin PBGAM Pinout (Continued)

| 484-PBGAM | VDDIO Bank | VREF Group | I/O | Pin Description | Additional Function | 484-PBGAM |
|-----------|------------|------------|--------|-----------------|---------------------|-----------|
| P15 | - | - | VDD15 | VDD15 | - | - |
| R6 | - | - | VDD15 | VDD15 | - | - |
| R15 | - | - | VDD15 | VDD15 | - | - |
| T4 | - | - | VDD15 | VDD15 | - | - |
| W19 | - | - | VDD15 | VDD15 | - | - |
| Y3 | - | - | VDD15 | VDD15 | - | - |
| Y19 | - | - | VDD15 | VDD15 | - | - |
| Y20 | - | - | VDD15 | VDD15 | - | - |
| T15 | - | - | VDD15 | VDD15 | - | - |
| T16 | - | - | VDD15 | VDD15 | - | - |
| U4 | - | - | VDD15 | VDD15 | - | - |
| T12 | - | - | VDD15 | VDD15 | - | - |
| T13 | - | - | VDD15 | VDD15 | - | - |
| T14 | - | - | VDD15 | VDD15 | - | - |
| T6 | - | - | VDD15 | VDD15 | - | - |
| T7 | - | - | VDD15 | VDD15 | - | - |
| T10 | - | - | VDD15 | VDD15 | - | - |
| T11 | - | - | VDD15 | VDD15 | - | - |
| G5 | 0 (TL) | - | VDDIO0 | VDDIO0 | - | - |
| H5 | 0 (TL) | - | VDDIO0 | VDDIO0 | - | - |
| J5 | 0 (TL) | - | VDDIO0 | VDDIO0 | - | - |
| V17 | 5 (BC) | - | VDDIO5 | VDDIO5 | - | - |
| W17 | 5 (BC) | - | VDDIO5 | VDDIO5 | - | - |
| W18 | 5 (BC) | - | VDDIO5 | VDDIO5 | - | - |
| M6 | 7 (CL) | - | VDDIO7 | VDDIO7 | - | - |
| N6 | 7 (CL) | - | VDDIO7 | VDDIO7 | - | - |
| U5 | - | - | VDD15 | VDD15 | - | - |
| U17 | - | - | VDD15 | VDD15 | - | - |
| V5 | - | - | VDD15 | VDD15 | - | - |
| V18 | - | - | VDD15 | VDD15 | - | - |
| R18 | - | - | VSS | VSS | - | - |
| R19 | - | - | VSS | VSS | - | - |
| T19 | - | - | VSS | VSS | - | - |
| U19 | - | - | VSS | VSS | - | - |
| U20 | - | - | VSS | VSS | - | - |
| V19 | - | - | VSS | VSS | - | - |
| V20 | - | - | VSS | VSS | - | - |
| W20 | - | - | VSS | VSS | - | - |
| Y21 | - | - | VSS | VSS | - | - |
| Y22 | - | - | VSS | VSS | - | - |
| L13 | - | - | VSS | VSS | - | - |
| L14 | - | - | VSS | VSS | - | - |
| M8 | - | - | VSS | VSS | - | - |
| M9 | - | - | VSS | VSS | - | - |

Table 51. ORSO42G5 484-pin PBGAM Pinout (Continued)

| 484-PBGAM | VDDIO Bank | VREF Group | I/O | Pin Description | Additional Function | 484-PBGAM |
|-----------|------------|------------|-----|-----------------|---------------------|-----------|
| M10 | - | - | VSS | VSS | - | - |
| M11 | - | - | VSS | VSS | - | - |
| M12 | - | - | VSS | VSS | - | - |
| M13 | - | - | VSS | VSS | - | - |
| M14 | - | - | VSS | VSS | - | - |
| N8 | - | - | VSS | VSS | - | - |
| N9 | - | - | VSS | VSS | - | - |
| N10 | - | - | VSS | VSS | - | - |
| N11 | - | - | VSS | VSS | - | - |
| N12 | - | - | VSS | VSS | - | - |
| N13 | - | - | VSS | VSS | - | - |
| N14 | - | - | VSS | VSS | - | - |
| P7 | - | - | VSS | VSS | - | - |
| P8 | - | - | VSS | VSS | - | - |
| P9 | - | - | VSS | VSS | - | - |
| P10 | - | - | VSS | VSS | - | - |
| P11 | - | - | VSS | VSS | - | - |
| P12 | - | - | VSS | VSS | - | - |
| P13 | - | - | VSS | VSS | - | - |
| P14 | - | - | VSS | VSS | - | - |
| R7 | - | - | VSS | VSS | - | - |
| R8 | - | - | VSS | VSS | - | - |
| R9 | - | - | VSS | VSS | - | - |
| R10 | - | - | VSS | VSS | - | - |
| R11 | - | - | VSS | VSS | - | - |
| R12 | - | - | VSS | VSS | - | - |
| R13 | - | - | VSS | VSS | - | - |
| R14 | - | - | VSS | VSS | - | - |
| AA1 | - | - | VSS | VSS | - | - |
| AA19 | - | - | VSS | VSS | - | - |
| AA20 | - | - | VSS | VSS | - | - |
| AA21 | - | - | VSS | VSS | - | - |
| AA22 | - | - | VSS | VSS | - | - |
| AB1 | - | - | VSS | VSS | - | - |
| AB19 | - | - | VSS | VSS | - | - |
| AB20 | - | - | VSS | VSS | - | - |
| AB21 | - | - | VSS | VSS | - | - |
| AB22 | - | - | VSS | VSS | - | - |

Table 52. ORSO82G5 680-Pin PBGAM (fpBGA) Pinout

| 680-PBGAM | VDDIO Bank | VREF Group | I/O | Pin Description | Additional Function | 680-PBGAM |
|-----------|------------|------------|--------|-----------------|---------------------|-----------|
| AB20 | — | — | Vss | Vss | — | — |
| C3 | — | — | VDD33 | VDD33 | — | — |
| E4 | — | — | O | PRD_DATA | RD_DATA/TDO | — |
| F5 | — | — | I | PRESET_N | RESET_N | — |
| G5 | — | — | I | PRD_CFG_N | RD_CFG_N | — |
| D3 | — | — | I | PPRGRM_N | PRGRM_N | — |
| A2 | 0 (TL) | — | VDDIO0 | VDDIO0 | — | — |
| F4 | 0 (TL) | 7 | IO | PL2D | PLL_CK0C/HPPLL | L21C_A0 |
| G4 | 0 (TL) | 7 | IO | PL2C | PLL_CK0T/HPPLL | L21T_A0 |
| B3 | 0 (TL) | — | VDDIO0 | VDDIO0 | — | — |
| C2 | 0 (TL) | 7 | IO | PL3D | — | L22C_D0 |
| B1 | 0 (TL) | 7 | IO | PL3C | VREF_0_07 | L22T_D0 |
| A1 | — | — | Vss | VSS | — | — |
| J5 | 0 (TL) | 7 | IO | PL4D | D5 | L23C_A0 |
| H5 | 0 (TL) | 7 | IO | PL4C | D6 | L23T_A0 |
| B7 | 0 (TL) | — | VDDIO0 | VDDIO0 | — | — |
| E3 | 0 (TL) | 8 | IO | PL4B | — | L24C_A0 |
| F3 | 0 (TL) | 8 | IO | PL4A | VREF_0_08 | L24T_A0 |
| C1 | 0 (TL) | 8 | IO | PL5D | HDC | L25C_D0 |
| D2 | 0 (TL) | 8 | IO | PL5C | LDC_N | L25T_D0 |
| A34 | — | — | VSS | VSS | — | — |
| G3 | 0 (TL) | 8 | IO | PL5B | — | L26C_D0 |
| H4 | 0 (TL) | 8 | IO | PL5A | — | L26T_D0 |
| E2 | 0 (TL) | 9 | IO | PL6D | TESTCFG | L27C_D0 |
| D1 | 0 (TL) | 9 | IO | PL6C | D7 | L27T_D0 |
| C5 | 0 (TL) | — | VDDIO0 | VDDIO0 | — | — |
| F2 | 0 (TL) | 9 | IO | PL7D | VREF_0_09 | L28C_D0 |
| E1 | 0 (TL) | 9 | IO | PL7C | A17/PPC_A31 | L28T_D0 |
| AA13 | — | — | VSS | VSS | — | — |
| J4 | 0 (TL) | 9 | IO | PL7B | — | L29C_D0 |
| K5 | 0 (TL) | 9 | IO | PL7A | — | L29T_D0 |
| H3 | 0 (TL) | 9 | IO | PL8D | CS0_N | L30C_D0 |
| G2 | 0 (TL) | 9 | IO | PL8C | CS1 | L30T_D0 |
| C9 | 0 (TL) | — | VDDIO0 | VDDIO0 | — | — |
| L5 | 0 (TL) | 9 | IO | PL8B | — | L31C_D0 |
| K4 | 0 (TL) | 9 | IO | PL8A | — | L31T_D0 |
| H2 | 0 (TL) | 10 | IO | PL9D | — | L32C_D0 |
| J3 | 0 (TL) | 10 | IO | PL9C | — | L32T_D0 |
| AA14 | — | — | VSS | VSS | — | — |
| M5 | 0 (TL) | 10 | IO | PL9B | — | — |
| F1 | 0 (TL) | 10 | IO | PL10D | INIT_N | L33C_A0 |
| G1 | 0 (TL) | 10 | IO | PL10C | DOUT | L33T_A0 |
| K3 | 0 (TL) | 10 | IO | PL11D | VREF_0_10 | L34C_D0 |
| J2 | 0 (TL) | 10 | IO | PL11C | A16/PPC_A30 | L34T_D0 |

Table 52. ORSO82G5 680-Pin PBGAM (fpBGA) Pinout (Continued)

| 680-PBGAM | VDDIO Bank | VREF Group | I/O | Pin Description | Additional Function | 680-PBGAM |
|-----------|------------|------------|--------|-----------------|---------------------|-----------|
| AA15 | — | — | VSS | VSS | — | — |
| L4 | 0 (TL) | 10 | IO | PL11B | — | — |
| N5 | 7 (CL) | 1 | IO | PL12D | A15/PPC_A29 | L1C_D0 |
| M4 | 7 (CL) | 1 | IO | PL12C | A14/PPC_A28 | L1T_D0 |
| AA3 | 7 (CL) | — | VDDIO7 | VDDIO7 | — | — |
| L3 | 7 (CL) | 1 | IO | PL12B | — | L2C_D0 |
| K2 | 7 (CL) | 1 | IO | PL12A | — | L2T_D0 |
| H1 | 7 (CL) | 1 | IO | PL13D | VREF_7_01 | L3C_A0 |
| J1 | 7 (CL) | 1 | IO | PL13C | D4 | L3T_A0 |
| V18 | — | — | VSS | VSS | — | — |
| N4 | 7 (CL) | 2 | IO | PL13B | — | L4C_D0 |
| P5 | 7 (CL) | 2 | IO | PL13A | — | L4T_D0 |
| M3 | 7 (CL) | 2 | IO | PL14D | RDY/BUSY_N/RCLK | L5C_D0 |
| L2 | 7 (CL) | 2 | IO | PL14C | VREF_7_02 | L5T_D0 |
| AC2 | 7 (CL) | — | VDDIO7 | VDDIO7 | — | — |
| K1 | 7 (CL) | 2 | IO | PL14B | — | L6C_A0 |
| L1 | 7 (CL) | 2 | IO | PL14A | — | L6T_A0 |
| P4 | 7 (CL) | 2 | IO | PL15D | A13/PPC_A27 | L7C_A0 |
| P3 | 7 (CL) | 2 | IO | PL15C | A12/PPC_A26 | L7T_A0 |
| V19 | — | — | VSS | VSS | — | — |
| M2 | 7 (CL) | 2 | IO | PL15B | — | L8C_A0 |
| M1 | 7 (CL) | 2 | IO | PL15A | — | L8T_A0 |
| N2 | 7 (CL) | 3 | IO | PL16D | — | L9C_A0 |
| N1 | 7 (CL) | 3 | IO | PL16C | — | L9T_A0 |
| N3 | 7 (CL) | — | VDDIO7 | VDDIO7 | — | — |
| R4 | 7 (CL) | 3 | IO | PL16B | — | — |
| P2 | 7 (CL) | 3 | IO | PL17D | A11/PPC_A25 | L10C_D0 |
| R3 | 7 (CL) | 3 | IO | PL17C | VREF_7_03 | L10T_D0 |
| W16 | — | — | VSS | VSS | — | — |
| R5 | 7 (CL) | 3 | IO | PL17B | — | — |
| P1 | 7 (CL) | 3 | IO | PL18D | — | L11C_A0 |
| R1 | 7 (CL) | 3 | IO | PL18C | — | L11T_A0 |
| T5 | 7 (CL) | 3 | IO | PL18B | — | L12C_A0 |
| T4 | 7 (CL) | 3 | IO | PL18A | — | L12T_A0 |
| T3 | 7 (CL) | 4 | IO | PL19D | RD_N/MPI_STRB_N | L13C_A0 |
| T2 | 7 (CL) | 4 | IO | PL19C | VREF_7_04 | L13T_A0 |
| W17 | — | — | VSS | VSS | — | — |
| U1 | 7 (CL) | 4 | IO | PL19B | — | L14C_A0 |
| T1 | 7 (CL) | 4 | IO | PL19A | — | L14T_A0 |
| U4 | 7 (CL) | 4 | IO | PL20D | PLCK0C | L15C_A0 |
| U5 | 7 (CL) | 4 | IO | PL20C | PLCK0T | L15T_A0 |
| R2 | 7 (CL) | — | VDDIO7 | VDDIO7 | — | — |
| U2 | 7 (CL) | 4 | IO | PL20B | — | L16C_D0 |
| V1 | 7 (CL) | 4 | IO | PL20A | — | L16T_D0 |

Table 52. ORSO82G5 680-Pin PBGAM (fpBGA) Pinout (Continued)

| 680-PBGAM | VDDIO Bank | VREF Group | I/O | Pin Description | Additional Function | 680-PBGAM |
|-----------|------------|------------|--------|-----------------|---------------------|-----------|
| W18 | — | — | VSS | VSS | — | — |
| V2 | 7 (CL) | 5 | IO | PL21D | A10/PPC_A24 | L17C_A0 |
| V3 | 7 (CL) | 5 | IO | PL21C | A9/PPC_A23 | L17T_A0 |
| W19 | — | — | VSS | VSS | — | — |
| V4 | 7 (CL) | 5 | IO | PL21B | — | L18C_A0 |
| V5 | 7 (CL) | 5 | IO | PL21A | — | L18T_A0 |
| W4 | 7 (CL) | 5 | IO | PL22D | A8/PPC_A22 | L19C_A0 |
| W3 | 7 (CL) | 5 | IO | PL22C | VREF_7_05 | L19T_A0 |
| W1 | 7 (CL) | 5 | IO | PL22B | — | L20C_A0 |
| Y1 | 7 (CL) | 5 | IO | PL22A | — | L20T_A0 |
| Y2 | 7 (CL) | 5 | IO | PL23D | — | L21C_D0 |
| AA1 | 7 (CL) | 5 | IO | PL23C | — | L21T_D0 |
| Y13 | — | — | VSS | VSS | — | — |
| Y4 | 7 (CL) | 5 | IO | PL23B | — | L22C_A0 |
| Y3 | 7 (CL) | 5 | IO | PL23A | — | L22T_A0 |
| Y5 | 7 (CL) | 6 | IO | PL24D | PLCK1C | L23C_A0 |
| W5 | 7 (CL) | 6 | IO | PL24C | PLCK1T | L23T_A0 |
| U3 | 7 (CL) | — | VDDIO7 | VDDIO7 | — | — |
| AB1 | 7 (CL) | 6 | IO | PL24B | — | L24C_D0 |
| AA2 | 7 (CL) | 6 | IO | PL24A | — | L24T_D0 |
| AB2 | 7 (CL) | 6 | IO | PL25D | VREF_7_06 | L25C_D0 |
| AC1 | 7 (CL) | 6 | IO | PL25C | A7/PPC_A21 | L25T_D0 |
| Y14 | — | — | VSS | VSS | — | — |
| AA4 | 7 (CL) | 6 | IO | PL25B | — | — |
| AB4 | 7 (CL) | 6 | IO | PL26D | A6/PPC_A20 | L26C_A0 |
| AB3 | 7 (CL) | 6 | IO | PL26C | A5/PPC_A19 | L26T_A0 |
| W2 | 7 (CL) | — | VDDIO7 | VDDIO7 | — | — |
| AD1 | 7 (CL) | 7 | IO | PL26B | — | — |
| AE1 | 7 (CL) | 7 | IO | PL27D | WR_N/MPI_RW | L27C_D0 |
| AD2 | 7 (CL) | 7 | IO | PL27C | VREF_7_07 | L27T_D0 |
| AC3 | 7 (CL) | 7 | IO | PL27B | — | L28C_A0 |
| AC4 | 7 (CL) | 7 | IO | PL27A | — | L28T_A0 |
| AF1 | 7 (CL) | 8 | IO | PL28D | A4/PPC_A18 | L29C_D0 |
| AE2 | 7 (CL) | 8 | IO | PL28C | VREF_7_08 | L29T_D0 |
| AB5 | 7 (CL) | 8 | IO | PL29D | A3/PPC_A17 | L30C_A0 |
| AA5 | 7 (CL) | 8 | IO | PL29C | A2/PPC_A16 | L30T_A0 |
| Y15 | — | — | VSS | VSS | — | — |
| AD3 | 7 (CL) | 8 | IO | PL29B | — | — |
| AG1 | 7 (CL) | 8 | IO | PL30D | A1/PPC_A15 | L31C_D0 |
| AF2 | 7 (CL) | 8 | IO | PL30C | A0/PPC_A14 | L31T_D0 |
| AD4 | 7 (CL) | 8 | IO | PL30B | — | L32C_D0 |
| AE3 | 7 (CL) | 8 | IO | PL30A | — | L32T_D0 |
| AD5 | 7 (CL) | 8 | IO | PL31D | DP0 | L33C_A0 |
| AC5 | 7 (CL) | 8 | IO | PL31C | DP1 | L33T_A0 |

Table 52. ORSO82G5 680-Pin PBGAM (fpBGA) Pinout (Continued)

| 680-PBGAM | VDDIO Bank | VREF Group | I/O | Pin Description | Additional Function | 680-PBGAM |
|-----------|------------|------------|--------|-----------------|---------------------|-----------|
| Y20 | — | — | VSS | VSS | — | — |
| AG2 | 7 (CL) | 8 | IO | PL31B | — | L34C_D0 |
| AH1 | 7 (CL) | 8 | IO | PL31A | — | L34T_D0 |
| AF3 | 6 (BL) | 1 | IO | PL32D | D8 | L1C_A0 |
| AG3 | 6 (BL) | 1 | IO | PL32C | VREF_6_01 | L1T_A0 |
| AL7 | 6 (BL) | — | VDDIO6 | VDDIO6 | — | — |
| AE4 | 6 (BL) | 1 | IO | PL32B | — | L2C_A0 |
| AF4 | 6 (BL) | 1 | IO | PL32A | — | L2T_A0 |
| AE5 | 6 (BL) | 1 | IO | PL33D | D9 | L3C_A0 |
| AF5 | 6 (BL) | 1 | IO | PL33C | D10 | L3T_A0 |
| R21 | — | — | VSS | VSS | — | — |
| AJ1 | 6 (BL) | 2 | IO | PL34D | — | L4C_D0 |
| AH2 | 6 (BL) | 2 | IO | PL34C | VREF_6_02 | L4T_D0 |
| AM5 | 6 (BL) | — | VDDIO6 | VDDIO6 | — | — |
| AK1 | 6 (BL) | 2 | IO | PL34B | — | L5C_D0 |
| AJ2 | 6 (BL) | 2 | IO | PL34A | — | L5T_D0 |
| R22 | — | — | VSS | VSS | — | — |
| AG4 | 6 (BL) | 3 | IO | PL35B | D11 | L6C_D0 |
| AH3 | 6 (BL) | 3 | IO | PL35A | D12 | L6T_D0 |
| AL1 | 6 (BL) | 3 | IO | PL36D | — | L7C_D0 |
| AK2 | 6 (BL) | 3 | IO | PL36C | — | L7T_D0 |
| AM9 | 6 (BL) | — | VDDIO6 | VDDIO6 | — | — |
| AM1 | 6 (BL) | 3 | IO | PL36B | VREF_6_03 | L8C_D0 |
| AL2 | 6 (BL) | 3 | IO | PL36A | D13 | L8T_D0 |
| AJ3 | 6 (BL) | 4 | IO | PL37D | — | — |
| T16 | — | — | VSS | VSS | — | — |
| AJ4 | 6 (BL) | 4 | IO | PL37B | — | L9C_A0 |
| AH4 | 6 (BL) | 4 | IO | PL37A | VREF_6_04 | L9T_A0 |
| AK3 | 6 (BL) | 4 | IO | PL38C | — | — |
| AN2 | 6 (BL) | — | VDDIO6 | VDDIO6 | — | — |
| AG5 | 6 (BL) | 4 | IO | PL38B | — | L10C_A0 |
| AH5 | 6 (BL) | 4 | IO | PL38A | — | L10T_A0 |
| AN1 | 6 (BL) | 4 | IO | PL39D | PLL_CK7C/HPPLL | L11C_D0 |
| AM2 | 6 (BL) | 4 | IO | PL39C | PLL_CK7T/HPPLL | L11T_D0 |
| T17 | — | — | VSS | VSS | — | — |
| AL3 | 6 (BL) | 4 | IO | PL39B | — | L12C_D0 |
| AK4 | 6 (BL) | 4 | IO | PL39A | — | L12T_D0 |
| T18 | — | — | VSS | VSS | — | — |
| AM3 | — | — | I | PTEMP | PTEMP | — |
| AN3 | 6 (BL) | — | VDDIO6 | VDDIO6 | — | — |
| AJ5 | — | — | IO | LVDS_R | LVDS_R | — |
| AL4 | — | — | VDD33 | VDD33 | — | — |
| T19 | — | — | VSS | VSS | — | — |
| AK5 | — | — | VDD33 | VDD33 | — | — |

Table 52. ORSO82G5 680-Pin PBGAM (fpBGA) Pinout (Continued)

| 680-PBGAM | VDDIO Bank | VREF Group | I/O | Pin Description | Additional Function | 680-PBGAM |
|-----------|------------|------------|--------|-----------------|---------------------|-----------|
| AM4 | 6 (BL) | 5 | IO | PB2A | DP2 | L13T_D0 |
| AL5 | 6 (BL) | 5 | IO | PB2B | — | L13C_D0 |
| AN7 | 6 (BL) | — | VDDIO6 | VDDIO6 | — | — |
| AP3 | 6 (BL) | 5 | IO | PB2C | PLL_CK6T/PPLL | L14T_A0 |
| AP4 | 6 (BL) | 5 | IO | PB2D | PLL_CK6C/PPLL | L14C_A0 |
| AN4 | 6 (BL) | 5 | IO | PB3B | — | — |
| U16 | — | — | VSS | VSS | — | — |
| AK6 | 6 (BL) | 5 | IO | PB3C | — | L15T_A0 |
| AK7 | 6 (BL) | 5 | IO | PB3D | — | L15C_A0 |
| AL6 | 6 (BL) | 5 | IO | PB4A | VREF_6_05 | L16T_A0 |
| AM6 | 6 (BL) | 5 | IO | PB4B | DP3 | L16C_A0 |
| AP1 | 6 (BL) | — | VDDIO6 | VDDIO6 | — | — |
| AN5 | 6 (BL) | 6 | IO | PB4C | — | L17T_A0 |
| AP5 | 6 (BL) | 6 | IO | PB4D | — | L17C_A0 |
| AK8 | 6 (BL) | 6 | IO | PB5B | — | — |
| U17 | — | — | VSS | VSS | — | — |
| AP6 | 6 (BL) | 6 | IO | PB5C | VREF_6_06 | L18T_D0 |
| AP7 | 6 (BL) | 6 | IO | PB5D | D14 | L18C_D0 |
| AM7 | 6 (BL) | 6 | IO | PB6A | — | L19T_D0 |
| AN6 | 6 (BL) | 6 | IO | PB6B | — | L19C_D0 |
| AP2 | 6 (BL) | — | VDDIO6 | VDDIO6 | — | — |
| AL8 | 6 (BL) | 7 | IO | PB6C | D15 | L20T_A0 |
| AL9 | 6 (BL) | 7 | IO | PB6D | D16 | L20C_A0 |
| AK9 | 6 (BL) | 7 | IO | PB7B | — | — |
| U18 | — | — | VSS | VSS | — | — |
| AN8 | 6 (BL) | 7 | IO | PB7C | D17 | L21T_A0 |
| AM8 | 6 (BL) | 7 | IO | PB7D | D18 | L21C_A0 |
| AN9 | 6 (BL) | 7 | IO | PB8A | — | L22T_D0 |
| AP8 | 6 (BL) | 7 | IO | PB8B | — | L22C_D0 |
| AK10 | 6 (BL) | 7 | IO | PB8C | VREF_6_07 | L23T_A0 |
| AL10 | 6 (BL) | 7 | IO | PB8D | D19 | L23C_A0 |
| AP9 | 6 (BL) | 8 | IO | PB9B | — | — |
| U19 | — | — | VSS | VSS | — | — |
| AM10 | 6 (BL) | 8 | IO | PB9C | D20 | L24T_A0 |
| AM11 | 6 (BL) | 8 | IO | PB9D | D21 | L24C_A0 |
| AK11 | 6 (BL) | 8 | IO | PB10B | — | — |
| AN10 | 6 (BL) | 8 | IO | PB10C | VREF_6_08 | L25T_A0 |
| AP10 | 6 (BL) | 8 | IO | PB10D | D22 | L25C_A0 |
| AN11 | 6 (BL) | 9 | IO | PB11A | — | L26T_A0 |
| AP11 | 6 (BL) | 9 | IO | PB11B | — | L26C_A0 |
| V16 | — | — | VSS | VSS | — | — |
| AL12 | 6 (BL) | 9 | IO | PB11C | D23 | L27T_A0 |
| AK12 | 6 (BL) | 9 | IO | PB11D | D24 | L27C_A0 |
| AN12 | 6 (BL) | 9 | IO | PB12A | — | L28T_A0 |

Table 52. ORSO82G5 680-Pin PBGAM (fpBGA) Pinout (Continued)

| 680-PBGAM | VDDIO Bank | VREF Group | I/O | Pin Description | Additional Function | 680-PBGAM |
|-----------|------------|------------|--------|-----------------|---------------------|-----------|
| AM12 | 6 (BL) | 9 | IO | PB12B | — | L28C_A0 |
| AP12 | 6 (BL) | 9 | IO | PB12C | VREF_6_09 | L29T_A0 |
| AP13 | 6 (BL) | 9 | IO | PB12D | D25 | L29C_A0 |
| AM13 | 6 (BL) | 9 | IO | PB13A | — | L30T_D0 |
| AN14 | 6 (BL) | 9 | IO | PB13B | — | L30C_D0 |
| V17 | — | — | VSS | VSS | — | — |
| AP14 | 6 (BL) | 10 | IO | PB13C | D26 | L31T_A0 |
| AP15 | 6 (BL) | 10 | IO | PB13D | D27 | L31C_A0 |
| AK13 | 6 (BL) | 10 | IO | PB14A | — | L32T_A0 |
| AK14 | 6 (BL) | 10 | IO | PB14B | — | L32C_A0 |
| AM14 | 6 (BL) | 10 | IO | PB14C | VREF_6_10 | L33T_A0 |
| AL14 | 6 (BL) | 10 | IO | PB14D | D28 | L33C_A0 |
| AP17 | 6 (BL) | 11 | IO | PB15A | — | L34T_A0 |
| AP16 | 6 (BL) | 11 | IO | PB15B | — | L34C_A0 |
| AM15 | 6 (BL) | 11 | IO | PB15C | D29 | L35T_D0 |
| AN16 | 6 (BL) | 11 | IO | PB15D | D30 | L35C_D0 |
| AM17 | 6 (BL) | 11 | IO | PB16A | — | L36T_A0 |
| AM16 | 6 (BL) | 11 | IO | PB16B | — | L36C_A0 |
| AP18 | 6 (BL) | 11 | IO | PB16C | VREF_6_11 | L37T_A0 |
| AP19 | 6 (BL) | 11 | IO | PB16D | D31 | L37C_A0 |
| AL16 | 5 (BC) | 1 | IO | PB17A | — | L1T_D0 |
| AK15 | 5 (BC) | 1 | IO | PB17B | — | L1C_D0 |
| N22 | — | — | VSS | VSS | — | — |
| AN18 | 5 (BC) | 1 | IO | PB17C | — | L2T_A0 |
| AN19 | 5 (BC) | 1 | IO | PB17D | — | L2C_A0 |
| AP20 | 5 (BC) | 1 | IO | PB18A | — | L3T_A0 |
| AP21 | 5 (BC) | 1 | IO | PB18B | — | L3C_A0 |
| AL17 | 5 (BC) | 1 | IO | PB18C | VREF_5_01 | L4T_D0 |
| AK16 | 5 (BC) | 1 | IO | PB18D | — | L4C_D0 |
| P13 | — | — | VSS | VSS | — | — |
| AM19 | 5 (BC) | 2 | IO | PB19A | — | L5T_A0 |
| AM18 | 5 (BC) | 2 | IO | PB19B | — | L5C_A0 |
| P14 | — | — | VSS | VSS | — | — |
| AN20 | 5 (BC) | 2 | IO | PB19C | PBCK0T | L6T_A0 |
| AM20 | 5 (BC) | 2 | IO | PB19D | PBCK0C | L6C_A0 |
| AK17 | 5 (BC) | 2 | IO | PB20A | — | L7T_D0 |
| AL18 | 5 (BC) | 2 | IO | PB20B | — | L7C_D0 |
| AL11 | 5 (BC) | — | VDDIO5 | VDDIO5 | — | — |
| AP22 | 5 (BC) | 2 | IO | PB20C | VREF_5_02 | L8T_D0 |
| AN21 | 5 (BC) | 2 | IO | PB20D | — | L8C_D0 |
| AM22 | 5 (BC) | 2 | IO | PB21A | — | L9T_A0 |
| AM21 | 5 (BC) | 2 | IO | PB21B | — | L9C_A0 |
| AP23 | 5 (BC) | 3 | IO | PB21C | — | L10T_D0 |
| AN22 | 5 (BC) | 3 | IO | PB21D | VREF_5_03 | L10C_D0 |

Table 52. ORSO82G5 680-Pin PBGAM (fpBGA) Pinout (Continued)

| 680-PBGAM | VDDIO Bank | VREF Group | I/O | Pin Description | Additional Function | 680-PBGAM |
|-----------|------------|------------|--------|-----------------|---------------------|-----------|
| AL19 | 5 (BC) | 3 | IO | PB22A | — | L11T_D0 |
| AK18 | 5 (BC) | 3 | IO | PB22B | — | L11C_D0 |
| P15 | — | — | VSS | VSS | — | — |
| AP24 | 5 (BC) | 3 | IO | PB22C | — | L12T_D0 |
| AN23 | 5 (BC) | 3 | IO | PB22D | — | L12C_D0 |
| AP25 | 5 (BC) | 3 | IO | PB23A | — | L13T_A0 |
| AP26 | 5 (BC) | 3 | IO | PB23B | — | L13C_A0 |
| AL13 | 5 (BC) | — | VDDIO5 | VDDIO5 | — | — |
| AL20 | 5 (BC) | 3 | IO | PB23C | PBCK1T | L14T_D0 |
| AK19 | 5 (BC) | 3 | IO | PB23D | PBCK1C | L14C_D0 |
| AK20 | 5 (BC) | 3 | IO | PB24A | — | L15T_D0 |
| AL21 | 5 (BC) | 3 | IO | PB24B | — | L15C_D0 |
| P20 | — | — | VSS | VSS | — | — |
| AN24 | 5 (BC) | 4 | IO | PB24C | — | L16T_D0 |
| AM23 | 5 (BC) | 4 | IO | PB24D | — | L16C_D0 |
| AN26 | 5 (BC) | 4 | IO | PB25A | — | L17T_A0 |
| AN25 | 5 (BC) | 4 | IO | PB25B | — | L17C_A0 |
| AL15 | 5 (BC) | — | VDDIO5 | VDDIO5 | — | — |
| AK21 | 5 (BC) | 4 | IO | PB25C | — | L18T_D0 |
| AL22 | 5 (BC) | 4 | IO | PB25D | VREF_5_04 | L18C_D0 |
| AM24 | 5 (BC) | 4 | IO | PB26A | — | L19T_D0 |
| AL23 | 5 (BC) | 4 | IO | PB26B | — | L19C_D0 |
| P21 | — | — | VSS | VSS | — | — |
| AP27 | 5 (BC) | 5 | IO | PB26C | — | L20T_A0 |
| AN27 | 5 (BC) | 5 | IO | PB26D | VREF_5_05 | L20C_A0 |
| AL24 | 5 (BC) | 5 | IO | PB27A | — | L21T_D0 |
| AM25 | 5 (BC) | 5 | IO | PB27B | — | L21C_D0 |
| AN13 | 5 (BC) | — | VDDIO5 | VDDIO5 | — | — |
| AP28 | 5 (BC) | 5 | IO | PB27C | — | L22T_A0 |
| AP29 | 5 (BC) | 5 | IO | PB27D | — | L22C_A0 |
| AN29 | 5 (BC) | 6 | IO | PB28B | — | — |
| P22 | — | — | VSS | VSS | — | — |
| AM27 | 5 (BC) | 6 | IO | PB28C | — | L23T_D0 |
| AN28 | 5 (BC) | 6 | IO | PB28D | VREF_5_06 | L23C_D0 |
| AM26 | 5 (BC) | 6 | IO | PB29B | — | — |
| AK22 | 5 (BC) | 6 | IO | PB29C | — | L24T_A0 |
| AK23 | 5 (BC) | 6 | IO | PB29D | — | L24C_A0 |
| AL25 | 5 (BC) | 7 | IO | PB30B | — | — |
| R13 | — | — | VSS | VSS | — | — |
| AP30 | 5 (BC) | 7 | IO | PB30C | — | L25T_A0 |
| AP31 | 5 (BC) | 7 | IO | PB30D | — | L25C_A0 |
| AK24 | 5 (BC) | 7 | IO | PB31B | — | — |
| AN15 | 5 (BC) | — | VDDIO5 | VDDIO5 | — | — |
| AM29 | 5 (BC) | 7 | IO | PB31C | VREF_5_07 | L26T_A0 |

Table 52. ORSO82G5 680-Pin PBGAM (fpBGA) Pinout (Continued)

| 680-PBGAM | VDDIO Bank | VREF Group | I/O | Pin Description | Additional Function | 680-PBGAM |
|-----------|------------|------------|---------|-----------------------|---------------------|-----------|
| AM28 | 5 (BC) | 7 | IO | PB31D | — | L26C_A0 |
| AN30 | 5 (BC) | 7 | IO | PB32B | — | — |
| R14 | — | — | VSS | VSS | — | — |
| AK25 | 5 (BC) | 7 | IO | PB32C | — | L27T_D0 |
| AL26 | 5 (BC) | 7 | IO | PB32D | — | L27C_D0 |
| AN17 | 5 (BC) | — | VDDIO5 | VDDIO5 | — | — |
| AL27 | 5 (BC) | 8 | IO | PB33C | — | L28T_A0 |
| AL28 | 5 (BC) | 8 | IO | PB33D | VREF_5_08 | L28C_A0 |
| AN31 | 5 (BC) | 8 | IO | PB34B | — | — |
| R15 | — | — | VSS | VSS | — | — |
| AK26 | 5 (BC) | 8 | IO | PB34D | — | — |
| AM30 | 5 (BC) | 9 | IO | PB35B | — | — |
| AL29 | 5 (BC) | 9 | IO | PB35D | VREF_5_09 | — |
| AK27 | 5 (BC) | 9 | IO | PB36B | — | — |
| R20 | — | — | VSS | VSS | — | — |
| AL30 | 5 (BC) | 9 | IO | PB36C | — | L29T_D0 |
| AK29 | 5 (BC) | 9 | IO | PB36D | — | L29C_D0 |
| AK28 | — | — | VDD33 | VDD33 | — | — |
| AA16 | — | — | VDD15 | VDD15 | — | — |
| AP32 | — | — | IO | PSCHAR_LDIO9 | — | — |
| AP33 | — | — | IO | PSCHAR_LDIO8 | — | — |
| AN32 | — | — | IO | PSCHAR_LDIO7 | — | — |
| AM31 | — | — | IO | PSCHAR_LDIO6 | — | — |
| AA17 | — | — | VDD15 | VDD15 | — | — |
| AM32 | — | — | VDD33 | VDD33 | — | — |
| AL31 | — | — | IO | PSCHAR_LDIO5 | — | — |
| AM33 | — | — | IO | PSCHAR_LDIO4 | — | — |
| AA18 | — | — | VDD15 | VDD15 | — | — |
| AK30 | — | — | IO | PSCHAR_LDIO3 | — | — |
| AL32 | — | — | IO | PSCHAR_LDIO2 | — | — |
| AA19 | — | — | VDD15 | VDD15 | — | — |
| AB16 | — | — | VDD15 | VDD15 | — | — |
| AK31 | — | — | VDD33 | VDD33 | — | — |
| AJ30 | — | — | IO | PSCHAR_LDIO1 | — | — |
| AK33 | — | — | IO | PSCHAR_LDIO0 | — | — |
| AK34 | — | — | IO | PSCHAR_CKIO1 | — | — |
| AJ31 | — | — | IO | PSCHAR_CKIO0 | — | — |
| AJ33 | — | — | IO | PSCHAR_XCK | — | — |
| AJ34 | — | — | IO | PSCHAR_WDSYNC | — | — |
| AH30 | — | — | IO | PSCHAR_CV | — | — |
| AH31 | — | — | IO | PSCHAR_BYTSYNC | — | — |
| AH32 | — | — | O | ATMOUT_B (no connect) | — | — |
| AH33 | — | — | VSS | VSS | — | — |
| AH34 | — | — | VDDGB_B | VDDGB_B | — | — |

Table 52. ORSO82G5 680-Pin PBGAM (fpBGA) Pinout (Continued)

| 680-PBGAM | VDDIO Bank | VREF Group | I/O | Pin Description | Additional Function | 680-PBGAM |
|-----------|------------|------------|---------|-----------------|---------------------|-----------|
| AA32 | — | — | VDD_ANA | VDD_ANA | — | — |
| AF30 | — | — | — | REXT_B | — | — |
| AF31 | — | — | — | REXTN_B | — | — |
| AE30 | — | — | I | REFCLKN_B | — | — |
| AE31 | — | — | I | REFCLKP_B | — | — |
| AB32 | — | — | VSS | VSS | — | — |
| AD30 | — | — | VDDIB | VDDIB_BA | — | — |
| AD32 | — | — | VDD_ANA | VDD_ANA | — | — |
| AF33 | — | — | I | HDINN_BA | — | — |
| AC32 | — | — | VSS | VSS | — | — |
| AF34 | — | — | I | HDINP_BA | — | — |
| AE32 | — | — | VDD_ANA | VDD_ANA | — | — |
| AD31 | — | — | VSS | VSS | — | — |
| K32 | — | — | VDD_ANA | VDD_ANA | — | — |
| AE33 | — | — | O | HDOUTN_BA | — | — |
| AF32 | — | — | VSS | VSS | — | — |
| AE34 | — | — | O | HDOUTP_BA | — | — |
| AC30 | — | — | VDDOB | VDDOB_BA | — | — |
| AG30 | — | — | VSS | VSS | — | — |
| AB30 | — | — | VDDIB | VDDIB_BB | — | — |
| AD33 | — | — | I | HDINN_BB | — | — |
| AG31 | — | — | VSS | VSS | — | — |
| AD34 | — | — | I | HDINP_BB | — | — |
| AC31 | — | — | VSS | VSS | — | — |
| AC33 | — | — | O | HDOUTN_BB | — | — |
| AG32 | — | — | VSS | VSS | — | — |
| AC34 | — | — | O | HDOUTP_BB | — | — |
| AB31 | — | — | VDDOB | VDDOB_BB | — | — |
| AG33 | — | — | VSS | VSS | — | — |
| AA30 | — | — | VDDIB | VDDIB_BC | — | — |
| AB33 | — | — | I | HDINN_BC | — | — |
| AG34 | — | — | VSS | VSS | — | — |
| AB34 | — | — | I | HDINP_BC | — | — |
| AA31 | — | — | VSS | VSS | — | — |
| Y30 | — | — | VDDOB | VDDOB_BC | — | — |
| AA33 | — | — | O | HDOUTN_BC | — | — |
| H30 | — | — | VSS | VSS | — | — |
| AA34 | — | — | O | HDOUTP_BC | — | — |
| Y31 | — | — | VDDOB | VDDOB_BC | — | — |
| H31 | — | — | VSS | VSS | — | — |
| W30 | — | — | VDDIB | VDDIB_BD | — | — |
| Y33 | — | — | I | HDINN_BD | — | — |
| H32 | — | — | VSS | VSS | — | — |
| Y34 | — | — | I | HDINP_BD | — | — |

Table 52. ORSO82G5 680-Pin PBGAM (fpBGA) Pinout (Continued)

| 680-PBGAM | VDDIO Bank | VREF Group | I/O | Pin Description | Additional Function | 680-PBGAM |
|-----------|------------|------------|---------|-----------------|---------------------|-----------|
| W31 | — | — | VSS | VSS | — | — |
| V30 | — | — | VDDOB | VDDOB_BD | — | — |
| W33 | — | — | O | HDOUTN_BD | — | — |
| H33 | — | — | VSS | VSS | — | — |
| W34 | — | — | O | HDOUTP_BD | — | — |
| V31 | — | — | VDDOB | VDDOB_BD | — | — |
| H34 | — | — | VSS | VSS | — | — |
| J32 | — | — | VSS | VSS | — | — |
| U31 | — | — | VDDOB | VDDOB_AD | — | — |
| T34 | — | — | O | HDOUTP_AD | — | — |
| M32 | — | — | VSS | VSS | — | — |
| T33 | — | — | O | HDOUTN_AD | — | — |
| U30 | — | — | VDDOB | VDDOB_AD | — | — |
| T31 | — | — | VSS | VSS | — | — |
| R34 | — | — | I | HDINP_AD | — | — |
| N32 | — | — | VSS | VSS | — | — |
| R33 | — | — | I | HDINN_AD | — | — |
| T30 | — | — | VDDIB | VDDIB_AD | — | — |
| U32 | — | — | VSS | VSS | — | — |
| R31 | — | — | VDDOB | VDDOB_AC | — | — |
| P34 | — | — | O | HDOUTP_AC | — | — |
| U33 | — | — | VSS | VSS | — | — |
| P33 | — | — | O | HDOUTN_AC | — | — |
| R30 | — | — | VDDOB | VDDOB_AC | — | — |
| P31 | — | — | VSS | VSS | — | — |
| N34 | — | — | I | HDINP_AC | — | — |
| U34 | — | — | VSS | VSS | — | — |
| N33 | — | — | I | HDINN_AC | — | — |
| P30 | — | — | VDDIB | VDDIB_AC | — | — |
| V32 | — | — | VSS | VSS | — | — |
| M34 | — | — | O | HDOUTP_AB | — | — |
| V33 | — | — | VSS | VSS | — | — |
| M33 | — | — | O | HDOUTN_AB | — | — |
| N31 | — | — | VDDOB | VDDOB_AB | — | — |
| M31 | — | — | VSS | VSS | — | — |
| L34 | — | — | I | HDINP_AB | — | — |
| V34 | — | — | VSS | VSS | — | — |
| L33 | — | — | I | HDINN_AB | — | — |
| N30 | — | — | VDDIB | VDDIB_AB | — | — |
| K34 | — | — | O | HDOUTP_AA | — | — |
| K33 | — | — | O | HDOUTN_AA | — | — |
| M30 | — | — | VDDOB | VDDOB_AA | — | — |
| L32 | — | — | VDD_ANA | VDD_ANA | — | — |
| L31 | — | — | VSS | VSS | — | — |

Table 52. ORSO82G5 680-Pin PBGAM (fpBGA) Pinout (Continued)

| 680-PBGAM | VDDIO Bank | VREF Group | I/O | Pin Description | Additional Function | 680-PBGAM |
|-----------|------------|------------|---------|-----------------------|---------------------|-----------|
| P32 | — | — | VDD_ANA | VDD_ANA | — | — |
| J34 | — | — | I | HDINP_AA | — | — |
| J33 | — | — | I | HDINN_AA | — | — |
| R32 | — | — | VDD_ANA | VDD_ANA | — | — |
| L30 | — | — | VDDIB | VDDIB_AA | — | — |
| K31 | — | — | — | REFCLKP_A | — | — |
| K30 | — | — | — | REFCLKN_A | — | — |
| J31 | — | — | O | REXTN_A | — | — |
| J30 | — | — | O | REXT_A | — | — |
| Y32 | — | — | VDD_ANA | VDD_ANA | — | — |
| G34 | — | — | VDDGB_A | VDDGB_A | — | — |
| G33 | — | — | VSS | VSS | — | — |
| G32 | — | — | O | ATMOUT_A (no connect) | — | — |
| G31 | — | — | I | PRESERVE01 | — | — |
| F33 | — | — | I | PRESERVE02 | — | — |
| G30 | — | — | I | PRESERVE03 | — | — |
| F31 | — | — | O | PSYS_RSSIG_ALL | — | — |
| F30 | — | — | I | PSYS_DOBISTN | — | — |
| E31 | — | — | VDD33 | VDD33 | — | — |
| AB17 | — | — | VDD15 | VDD15 | — | — |
| AB18 | — | — | VDD15 | VDD15 | — | — |
| D32 | — | — | I | PBIST_TEST_ENN | — | — |
| E30 | — | — | I | PLOOP_TEST_ENN | — | — |
| AB19 | — | — | VDD15 | VDD15 | — | — |
| D31 | — | — | I | PASB_PDN | — | — |
| C32 | — | — | I | PMP_TESTCLK | — | — |
| C31 | — | — | VDD33 | VDD33 | — | — |
| AJ32 | — | — | VDD15 | VDD15 | — | — |
| B32 | — | — | I | PASB_RESETN | — | — |
| A33 | — | — | I | PASB_TRISTN | — | — |
| B31 | — | — | I | PMP_TESTCLK_ENN | — | — |
| A32 | — | — | I | PASB_TESTCLK | — | — |
| AK32 | — | — | VDD15 | VDD15 | — | — |
| AB21 | — | — | VSS | VSS | — | — |
| A31 | — | — | VDD33 | VDD33 | — | — |
| B30 | 1 (TC) | 7 | IO | PT36D | — | — |
| AB22 | — | — | VSS | VSS | — | — |
| C30 | 1 (TC) | 7 | IO | PT36B | — | — |
| D30 | 1 (TC) | 7 | IO | PT35D | — | — |
| B13 | 1 (TC) | — | VDDIO1 | VDDIO1 | — | — |
| E29 | 1 (TC) | 7 | IO | PT35B | — | — |
| E28 | 1 (TC) | 7 | IO | PT34D | VREF_1_07 | — |
| AN33 | — | — | VSS | Vss | — | — |
| D29 | 1 (TC) | 8 | IO | PT34B | — | — |

Table 52. ORSO82G5 680-Pin PBGAM (fpBGA) Pinout (Continued)

| 680-PBGAM | VDDIO Bank | VREF Group | I/O | Pin Description | Additional Function | 680-PBGAM |
|-----------|------------|------------|--------|-----------------|---------------------|-----------|
| B29 | 1 (TC) | 8 | IO | PT33D | — | L1C_A0 |
| C29 | 1 (TC) | 8 | IO | PT33C | VREF_1_08 | L1T_A0 |
| B15 | 1 (TC) | — | VDDIO1 | VDDIO1 | — | — |
| E27 | 1 (TC) | 8 | IO | PT32D | — | L2C_A0 |
| E26 | 1 (TC) | 8 | IO | PT32C | — | L2T_A0 |
| AP34 | — | — | Vss | Vss | — | — |
| A30 | 1 (TC) | 8 | IO | PT32B | — | — |
| A29 | 1 (TC) | 9 | IO | PT31D | — | L3C_D3 |
| E25 | 1 (TC) | 9 | IO | PT31C | VREF_1_09 | L3T_D3 |
| B17 | 1 (TC) | — | VDDIO1 | VDDIO1 | — | — |
| E24 | 1 (TC) | 9 | IO | PT31A | — | — |
| B28 | 1 (TC) | 9 | IO | PT30D | — | L4C_A0 |
| C28 | 1 (TC) | 9 | IO | PT30C | — | L4T_A0 |
| B2 | — | — | Vss | Vss | — | — |
| D28 | 1 (TC) | 9 | IO | PT30A | — | — |
| C27 | 1 (TC) | 9 | IO | PT29D | — | L5C_A0 |
| D27 | 1 (TC) | 9 | IO | PT29C | — | L5T_A0 |
| E23 | 1 (TC) | 9 | IO | PT29B | — | L6C_A0 |
| E22 | 1 (TC) | 9 | IO | PT29A | — | L6T_A0 |
| D26 | 1 (TC) | 1 | IO | PT28D | — | L7C_A0 |
| D25 | 1 (TC) | 1 | IO | PT28C | — | L7T_A0 |
| B33 | — | — | Vss | Vss | — | — |
| D24 | 1 (TC) | 1 | IO | PT28B | — | L8C_A0 |
| D23 | 1 (TC) | 1 | IO | PT28A | — | L8T_A0 |
| C26 | 1 (TC) | 1 | IO | PT27D | VREF_1_01 | L9C_A0 |
| C25 | 1 (TC) | 1 | IO | PT27C | — | L9T_A0 |
| D11 | 1 (TC) | — | VDDIO1 | VDDIO1 | — | — |
| E21 | 1 (TC) | 1 | IO | PT27B | — | L10C_A0 |
| E20 | 1 (TC) | 1 | IO | PT27A | — | L10T_A0 |
| D22 | 1 (TC) | 2 | IO | PT26D | — | L11C_A0 |
| D21 | 1 (TC) | 2 | IO | PT26C | VREF_1_02 | L11T_A0 |
| E34 | — | — | Vss | Vss | — | — |
| A28 | 1 (TC) | 2 | IO | PT26B | — | — |
| B26 | 1 (TC) | 2 | IO | PT25D | — | L12C_A0 |
| B25 | 1 (TC) | 2 | IO | PT25C | — | L12T_A0 |
| D13 | 1 (TC) | — | VDDIO1 | VDDIO1 | — | — |
| B27 | 1 (TC) | 2 | IO | PT25B | — | — |
| A27 | 1 (TC) | 3 | IO | PT24D | — | L13C_A0 |
| A26 | 1 (TC) | 3 | IO | PT24C | VREF_1_03 | L13T_A0 |
| N13 | — | — | Vss | Vss | — | — |
| C24 | 1 (TC) | 3 | IO | PT24B | — | — |
| C22 | 1 (TC) | 3 | IO | PT23D | — | L14C_A0 |
| C23 | 1 (TC) | 3 | IO | PT23C | — | L14T_A0 |
| D15 | 1 (TC) | — | VDDIO1 | VDDIO1 | — | — |

Table 52. ORSO82G5 680-Pin PBGAM (fpBGA) Pinout (Continued)

| 680-PBGAM | VDDIO Bank | VREF Group | I/O | Pin Description | Additional Function | 680-PBGAM |
|-----------|------------|------------|-----|-----------------|---------------------|-----------|
| B24 | 1 (TC) | 3 | IO | PT23B | — | — |
| D20 | 1 (TC) | 3 | IO | PT22D | — | L15C_A0 |
| D19 | 1 (TC) | 3 | IO | PT22C | — | L15T_A0 |
| N14 | — | — | Vss | Vss | — | — |
| E19 | 1 (TC) | 3 | IO | PT22B | — | L16C_A0 |
| E18 | 1 (TC) | 3 | IO | PT22A | — | L16T_A0 |
| C21 | 1 (TC) | 4 | IO | PT21D | — | L17C_A0 |
| C20 | 1 (TC) | 4 | IO | PT21C | — | L17T_A0 |
| A25 | 1 (TC) | 4 | IO | PT21B | — | L18C_A0 |
| A24 | 1 (TC) | 4 | IO | PT21A | — | L18T_A0 |
| B23 | 1 (TC) | 4 | IO | PT20D | — | L19C_A0 |
| A23 | 1 (TC) | 4 | IO | PT20C | — | L19T_A0 |
| N15 | — | — | Vss | Vss | — | — |
| E17 | 1 (TC) | 4 | IO | PT20B | — | L20C_A0 |
| E16 | 1 (TC) | 4 | IO | PT20A | — | L20T_A0 |
| B22 | 1 (TC) | 4 | IO | PT19D | — | L21C_A0 |
| B21 | 1 (TC) | 4 | IO | PT19C | VREF_1_04 | L21T_A0 |
| C18 | 1 (TC) | 4 | IO | PT19B | — | L22C_A0 |
| C19 | 1 (TC) | 4 | IO | PT19A | — | L22T_A0 |
| N20 | — | — | Vss | Vss | — | — |
| A22 | 1 (TC) | 5 | IO | PT18D | PTCK1C | L23C_A0 |
| A21 | 1 (TC) | 5 | IO | PT18C | PTCK1T | L23T_A0 |
| N21 | — | — | Vss | Vss | — | — |
| D17 | 1 (TC) | 5 | IO | PT18B | — | L24C_A0 |
| D18 | 1 (TC) | 5 | IO | PT18A | — | L24T_A0 |
| B20 | 1 (TC) | 5 | IO | PT17D | PTCK0C | L25C_A0 |
| B19 | 1 (TC) | 5 | IO | PT17C | PTCK0T | L25T_A0 |
| A20 | 1 (TC) | 5 | IO | PT17B | — | L26C_A0 |
| A19 | 1 (TC) | 5 | IO | PT17A | — | L26T_A0 |
| A18 | 1 (TC) | 5 | IO | PT16D | VREF_1_05 | L27C_A0 |
| B18 | 1 (TC) | 5 | IO | PT16C | — | L27T_A0 |
| Y21 | — | — | Vss | Vss | — | — |
| C17 | 1 (TC) | 5 | IO | PT16B | — | L28C_D0 |
| D16 | 1 (TC) | 5 | IO | PT16A | — | L28T_D0 |
| A17 | 1 (TC) | 6 | IO | PT15D | — | L29C_D0 |
| B16 | 1 (TC) | 6 | IO | PT15C | — | L29T_D0 |
| E15 | 1 (TC) | 6 | IO | PT15B | — | L30C_A0 |
| E14 | 1 (TC) | 6 | IO | PT15A | — | L30T_A0 |
| A16 | 1 (TC) | 6 | IO | PT14D | — | L31C_A0 |
| A15 | 1 (TC) | 6 | IO | PT14C | VREF_1_06 | L31T_A0 |
| Y22 | — | — | Vss | Vss | — | — |
| D14 | 1 (TC) | 6 | IO | PT14B | — | — |
| C16 | 0 (TL) | 1 | IO | PT13D | MPI_RTRY_N | L1C_A0 |
| C15 | 0 (TL) | 1 | IO | PT13C | MPI_ACK_N | L1T_A0 |

Table 52. ORSO82G5 680-Pin PBGAM (fpBGA) Pinout (Continued)

| 680-PBGAM | VDDIO Bank | VREF Group | I/O | Pin Description | Additional Function | 680-PBGAM |
|-----------|------------|------------|--------|-----------------|---------------------|-----------|
| D7 | 0 (TL) | — | VDDIO0 | VDDIO0 | — | — |
| C14 | 0 (TL) | 1 | IO | PT13B | — | L2C_A0 |
| B14 | 0 (TL) | 1 | IO | PT13A | VREF_0_01 | L2T_A0 |
| A14 | 0 (TL) | 1 | IO | PT12D | M0 | L3C_A0 |
| A13 | 0 (TL) | 1 | IO | PT12C | M1 | L3T_A0 |
| AA20 | — | — | Vss | Vss | — | — |
| E12 | 0 (TL) | 2 | IO | PT12B | MPI_CLK | L4C_A0 |
| E13 | 0 (TL) | 2 | IO | PT12A | A21/MPI_BURST_N | L4T_A0 |
| C13 | 0 (TL) | 2 | IO | PT11D | M2 | L5C_A0 |
| C12 | 0 (TL) | 2 | IO | PT11C | M3 | L5T_A0 |
| B12 | 0 (TL) | 2 | IO | PT11B | VREF_0_02 | L6C_A0 |
| A12 | 0 (TL) | 2 | IO | PT11A | MPI_TEA_N | L6T_A0 |
| D12 | 0 (TL) | 3 | IO | PT10D | — | L7C_D0 |
| C11 | 0 (TL) | 3 | IO | PT10C | — | L7T_D0 |
| B11 | 0 (TL) | 3 | IO | PT10B | — | — |
| A11 | 0 (TL) | 3 | IO | PT9D | VREF_0_03 | L8C_A0 |
| A10 | 0 (TL) | 3 | IO | PT9C | — | L8T_A0 |
| AA21 | — | — | Vss | Vss | — | — |
| B10 | 0 (TL) | 3 | IO | PT9B | — | — |
| E11 | 0 (TL) | 3 | IO | PT8D | D0 | L9C_D0 |
| D10 | 0 (TL) | 3 | IO | PT8C | TMS | L9T_D0 |
| C10 | 0 (TL) | 3 | IO | PT8B | — | — |
| A9 | 0 (TL) | 4 | IO | PT7D | A20/MPI_BDIP_N | L10C_A0 |
| B9 | 0 (TL) | 4 | IO | PT7C | A19/MPI_TSZ1 | L10T_A0 |
| AA22 | — | — | Vss | Vss | — | — |
| E10 | 0 (TL) | 4 | IO | PT7B | — | — |
| A8 | 0 (TL) | 4 | IO | PT6D | A18/MPI_TSZ0 | L11C_A0 |
| B8 | 0 (TL) | 4 | IO | PT6C | D3 | L11T_A0 |
| D9 | 0 (TL) | 4 | IO | PT6B | VREF_0_04 | L12C_D0 |
| C8 | 0 (TL) | 4 | IO | PT6A | — | L12T_D0 |
| E9 | 0 (TL) | 5 | IO | PT5D | D1 | L13C_D0 |
| D8 | 0 (TL) | 5 | IO | PT5C | D2 | L13T_D0 |
| AB13 | — | — | Vss | Vss | — | — |
| A7 | 0 (TL) | 5 | IO | PT5B | — | L14C_A0 |
| A6 | 0 (TL) | 5 | IO | PT5A | VREF_0_05 | L14T_A0 |
| C7 | 0 (TL) | 5 | IO | PT4D | TDI | L15C_D0 |
| B6 | 0 (TL) | 5 | IO | PT4C | TCK | L15T_D0 |
| E8 | 0 (TL) | 5 | IO | PT4B | — | L16C_A0 |
| E7 | 0 (TL) | 5 | IO | PT4A | — | L16T_A0 |
| A5 | 0 (TL) | 6 | IO | PT3D | — | L17C_A0 |
| B5 | 0 (TL) | 6 | IO | PT3C | VREF_0_06 | L17T_A0 |
| AB14 | — | — | Vss | Vss | — | — |
| C6 | 0 (TL) | 6 | IO | PT3B | — | L18C_A0 |
| D6 | 0 (TL) | 6 | IO | PT3A | — | L18T_A0 |

Table 52. ORSO82G5 680-Pin PBGAM (fpBGA) Pinout (Continued)

| 680-PBGAM | VDDIO Bank | VREF Group | I/O | Pin Description | Additional Function | 680-PBGAM |
|-----------|------------|------------|-------|-----------------|---------------------|-----------|
| C4 | 0 (TL) | 6 | IO | PT2D | PLL_CK1C/PPLL | L19C_A0 |
| B4 | 0 (TL) | 6 | IO | PT2C | PLL_CK1T/PPLL | L19T_A0 |
| A4 | 0 (TL) | 6 | IO | PT2B | — | L20C_A0 |
| A3 | 0 (TL) | 6 | IO | PT2A | — | L20T_A0 |
| D5 | — | — | O | PCFG_MPI_IRQ | CFG_IRQ_N/MPI_IRQ_N | — |
| E6 | — | — | IO | PCCLK | CCLK | — |
| D4 | — | — | IO | PDONE | DONE | — |
| E5 | — | — | VDD33 | VDD33 | — | — |
| AB15 | — | — | Vss | Vss | — | — |
| AL33 | — | — | VDD15 | VDD15 | — | — |
| AL34 | — | — | VDD15 | VDD15 | — | — |
| AM34 | — | — | VDD15 | VDD15 | — | — |
| AN34 | — | — | VDD15 | VDD15 | — | — |
| B34 | — | — | VDD15 | VDD15 | — | — |
| C33 | — | — | VDD15 | VDD15 | — | — |
| C34 | — | — | VDD15 | VDD15 | — | — |
| D33 | — | — | VDD15 | VDD15 | — | — |
| D34 | — | — | VDD15 | VDD15 | — | — |
| E32 | — | — | VDD15 | VDD15 | — | — |
| E33 | — | — | VDD15 | VDD15 | — | — |
| F32 | — | — | VDD15 | VDD15 | — | — |
| F34 | — | — | VDD15 | VDD15 | — | — |
| N16 | — | — | VDD15 | VDD15 | — | — |
| N17 | — | — | VDD15 | VDD15 | — | — |
| N18 | — | — | VDD15 | VDD15 | — | — |
| N19 | — | — | VDD15 | VDD15 | — | — |
| P16 | — | — | VDD15 | VDD15 | — | — |
| P17 | — | — | VDD15 | VDD15 | — | — |
| P18 | — | — | VDD15 | VDD15 | — | — |
| P19 | — | — | VDD15 | VDD15 | — | — |
| R16 | — | — | VDD15 | VDD15 | — | — |
| R17 | — | — | VDD15 | VDD15 | — | — |
| R18 | — | — | VDD15 | VDD15 | — | — |
| R19 | — | — | VDD15 | VDD15 | — | — |
| T13 | — | — | VDD15 | VDD15 | — | — |
| T14 | — | — | VDD15 | VDD15 | — | — |
| T15 | — | — | VDD15 | VDD15 | — | — |
| T20 | — | — | VDD15 | VDD15 | — | — |
| T21 | — | — | VDD15 | VDD15 | — | — |
| T22 | — | — | VDD15 | VDD15 | — | — |
| U13 | — | — | VDD15 | VDD15 | — | — |
| U14 | — | — | VDD15 | VDD15 | — | — |
| U15 | — | — | VDD15 | VDD15 | — | — |
| U20 | — | — | VDD15 | VDD15 | — | — |

Table 52. ORSO82G5 680-Pin PBGAM (fpBGA) Pinout (Continued)

| 680-PBGAM | VDDIO Bank | VREF Group | I/O | Pin Description | Additional Function | 680-PBGAM |
|-----------|------------|------------|-------|-----------------|---------------------|-----------|
| U21 | — | — | VDD15 | VDD15 | — | — |
| U22 | — | — | VDD15 | VDD15 | — | — |
| V13 | — | — | VDD15 | VDD15 | — | — |
| V14 | — | — | VDD15 | VDD15 | — | — |
| V15 | — | — | VDD15 | VDD15 | — | — |
| V20 | — | — | VDD15 | VDD15 | — | — |
| V21 | — | — | VDD15 | VDD15 | — | — |
| V22 | — | — | VDD15 | VDD15 | — | — |
| W13 | — | — | VDD15 | VDD15 | — | — |
| W14 | — | — | VDD15 | VDD15 | — | — |
| W15 | — | — | VDD15 | VDD15 | — | — |
| W20 | — | — | VDD15 | VDD15 | — | — |
| W21 | — | — | VDD15 | VDD15 | — | — |
| W22 | — | — | VDD15 | VDD15 | — | — |
| Y16 | — | — | VDD15 | VDD15 | — | — |
| Y17 | — | — | VDD15 | VDD15 | — | — |
| Y18 | — | — | VDD15 | VDD15 | — | — |
| Y19 | — | — | VDD15 | VDD15 | — | — |
| T32 | — | — | NC | NC | — | — |
| W32 | — | — | NC | NC | — | — |

Package Thermal Characteristics Summary

There are three thermal parameters that are in common use: Θ_{JA} , ψ_{JC} , and Θ_{JC} . It should be noted that all the parameters are affected, to varying degrees, by package design (including paddle size) and choice of materials, the amount of copper in the test board or system board, and system airflow.

Θ_{JA}

This is the thermal resistance from junction to ambient (theta-JA):

$$\Theta_{JA} = \frac{T_J - T_A}{Q} \quad (1)$$

where T_J is the junction temperature, T_A is the ambient air temperature, and Q is the chip power.

Experimentally, Θ_{JA} is determined when a special thermal test die is assembled into the package of interest, and the part is mounted on the thermal test board. The diodes on the test chip are separately calibrated in an oven. The package/board is placed either in a JEDEC natural convection box or in the wind tunnel, the latter for forced convection measurements. A controlled amount of power (Q) is dissipated in the test chip's heater resistor, the chip's temperature (T_J) is determined by the forward drop on the diodes, and the ambient temperature (T_A) is noted. Note that Θ_{JA} is expressed in units of $^{\circ}\text{C}/\text{W}$.

ψ_{JC}

This JEDEC designated parameter correlates the junction temperature to the case temperature. It is generally used to infer the junction temperature while the device is operating in the system. It is not considered a true thermal resistance and it is defined by:

$$\psi_{JC} = \frac{T_J - T_C}{Q} \quad (2)$$

where T_C is the case temperature at top dead center, T_J is the junction temperature, and Q is the chip power. During the Θ_{JA} measurements described above, besides the other parameters measured, an additional temperature reading, T_C , is made with a thermocouple attached at top-dead-center of the case. ψ_{JC} is also expressed in units of $^{\circ}\text{C}/\text{W}$.

Θ_{JC}

This is the thermal resistance from junction to case. It is most often used when attaching a heat sink to the top of the package. It is defined by:

$$\Theta_{JC} = \frac{T_J - T_C}{Q} \quad (3)$$

The parameters in this equation have been defined above. However, the measurements are performed with the case of the part pressed against a water-cooled heat sink to draw most of the heat generated by the chip out the top of the package. It is this difference in the measurement process that differentiates Θ_{JC} from ψ_{JC} . Θ_{JC} is a true thermal resistance and is expressed in units of $^{\circ}\text{C}/\text{W}$.

Θ_{JB}

This is the thermal resistance from junction to board. It is defined by:

$$\Theta_{JB} = \frac{T_J - T_B}{Q} \quad (4)$$

where T_B is the temperature of the board adjacent to a lead measured with a thermocouple. The other parameters on the right-hand side have been defined above. This is considered a true thermal resistance, and the measurement is made with a water-cooled heat sink pressed against the board to draw most of the heat out of the leads.

Note that Θ_{JB} is expressed in units of $^{\circ}\text{C}/\text{W}$ and that this parameter and the way it is measured are still being discussed by the JEDEC committee.

FPSC Maximum Junction Temperature

Once the power dissipated by the FPSC has been determined, the maximum junction temperature of the FPSC can be found. This is needed to determine if speed derating of the device from the 85°C junction temperature used in all of the delay tables is needed. Derating calculations for other temperatures than 85°C and for other voltages can be made within the ispLEVER software environment. Using the maximum ambient temperature, T_{Amax} , and the power dissipated by the device, Q (expressed in $^{\circ}\text{C}$), the maximum junction temperature is approximated by:

$$T_{Jmax} = T_{Amax} + (Q \cdot \Theta_{JB}) \quad (5)$$

Package Thermal Characteristics

The thermal characteristics of the 484-ball PBGAM (fpBGA with heat spreader) used for the ORT42G5, 680-ball PBGAM (fpBGA with heat spreader) and 680-ball fpBGA used for the ORT82G5 are available in the Thermal Management section of the Lattice web site at www.latticesemi.com.

Heat Sink Vendors for BGA Packages

The estimated worst-case power requirements for the ORSO42G5 and ORSO82G5 are in the 3 W to 5 W range. Consequently, for most applications an external heat sink will be required. Table 53 lists, in alphabetical order, heat sink vendors who advertise heat sinks aimed at the BGA market.

Table 53. Heat Sink Vendors

| Vendor | Location | Phone |
|--------------------------|---------------|----------------|
| Aavid Thermal Technology | Laconia, NH | (603) 527-2152 |
| Chip Coolers | Warwick, RI | (800) 227-0254 |
| IERC | Burbank, CA | (818) 842-7277 |
| R-Theta | Buffalo, NY | (800) 388-5428 |
| Sanyo Denki | Torrance, CA | (310) 783-5400 |
| Thermalloy | Dallas, TX | (214) 243-4321 |
| Wakefield Engineering | Wakefield, MA | (617) 246-0874 |

Package Parasitics

The electrical performance of an IC package, such as signal quality and noise sensitivity, is directly affected by the package parasitics. Table 54 lists eight parasitics associated with the ORCA packages. These parasitics represent the contributions of all components of a package, which include the bond wires, all internal package routing, and the external leads.

Four inductances in nH are listed: LSW and LSL, the self-inductance of the lead; and LMW and LML, the mutual inductance to the nearest neighbor lead. These parameters are important in determining ground bounce noise and inductive crosstalk noise. Three capacitances in pF are listed: CM, the mutual capacitance of the lead to the nearest neighbor lead; and C1 and C2, the total capacitance of the lead to all other leads (all other leads are assumed to be grounded). These parameters are important in determining capacitive crosstalk and the capacitive loading effect of the lead. Resistance values are in $\text{m}\Omega$.

The parasitic values in Table 54 are for the circuit model of bond wire and package lead parasitics. If the mutual capacitance value is not used in the designer's model, then the value listed as mutual capacitance should be added to each of the C1 and C2 capacitors.

Table 54. ORCA Typical Package Parasitics

| LSW | LMW | RW | C1 | C2 | CM | LSL | LML |
|-----|-----|-----|-----|-----|-----|-------|--------|
| 3.8 | 1.3 | 250 | 1.0 | 1.0 | 0.3 | 2.8-5 | 0.5 -1 |

Figure 53. Package Parasitics

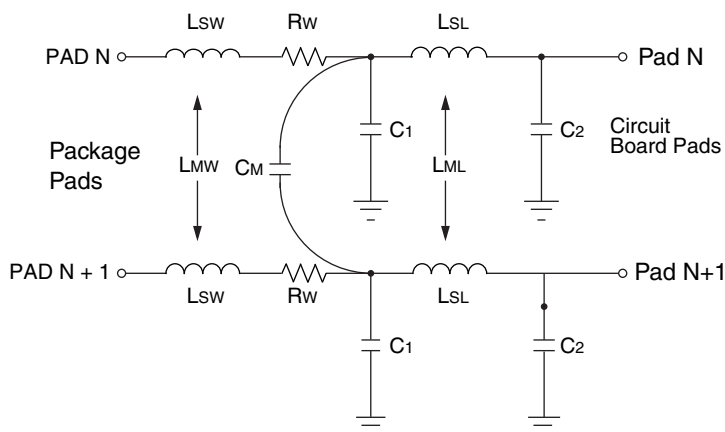

Package Outline Drawings

Package Outline Drawings for the 484-ball PBGAM (fpBGA) used for the ORSO42G5 and 680-ball PBGAM (fpBGA) used for the ORSO82G5 are available at the Package Diagrams section of the Lattice Semiconductor web site at www.latticesemi.com.

Part Number Description

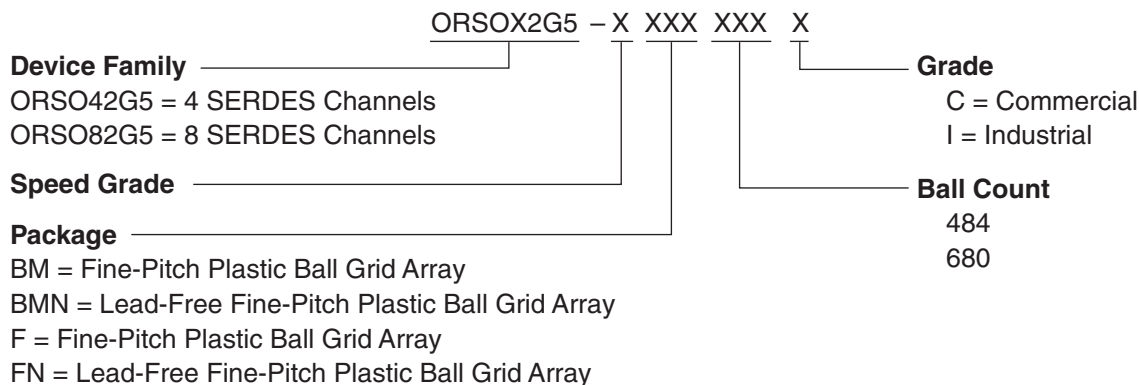

Device Type Options

| Device | Voltage |
|----------|---------------------------------------|
| ORSO42G5 | 1.5V internal 3.3/2.5/1.8/1.5V I/O |
| ORSO82G5 | 1.5V internal 3.3/2.5/1.8/1.5V I/O |

Ordering Information

Conventional Packaging

Commercial¹

| Device Family | Part Number | Speed Grade | Package Type | Ball Count | Grade |
|---------------|-------------------------------|-------------|----------------------------|------------|-------|
| ORSO42G5 | ORSO42G5-3BM484C | 3 | PBGAM | 484 | C |
| | ORSO42G5-2BM484C | 2 | PBGAM | 484 | C |
| | ORSO42G5-1BM484C | 1 | PBGAM | 484 | C |
| ORSO82G5 | ORSO82G5-3F680C | 3 | PBGAM (No Heat Spreader) | 680 | C |
| | ORSO82G5-2F680C | 2 | PBGAM (No Heat Spreader) | 680 | C |
| | ORSO82G5-1F680C | 1 | PBGAM (No Heat Spreader) | 680 | C |
| | ORSO82G5-3BM680C ² | 3 | PBGAM (With Heat Spreader) | 680 | C |
| | ORSO82G5-2BM680C ² | 2 | PBGAM (With Heat Spreader) | 680 | C |
| | ORSO82G5-1BM680C ² | 1 | PBGAM (With Heat Spreader) | 680 | C |

- For all but the slowest commercial speed grade, the speed grades on these devices are dual marked. For example, the commercial speed grade -2XXXXXC is also marked with the industrial grade -1XXXXXI. The commercial grade is always one speed grade faster than the associated dual mark industrial grade. The slowest commercial speed grade is marked as commercial grade only.
- BM680 package was converted to F680 via PCN#09A-08.

Industrial¹

| Device Family | Part Number | Speed Grade | Package Type | Ball Count | Grade |
|---------------|-------------------------------|-------------|----------------------------|------------|-------|
| ORSO42G5 | ORSO42G5-2BM484I | 2 | PBGAM | 484 | I |
| | ORSO42G5-1BM484I | 1 | PBGAM | 484 | I |
| ORSO82G5 | ORSO82G5-2F680I | 2 | PBGAM (No Heat Spreader) | 680 | I |
| | ORSO82G5-1F680I | 1 | PBGAM (No Heat Spreader) | 680 | I |
| | ORSO82G5-2BM680I ² | 2 | PBGAM (With Heat Spreader) | 680 | I |
| | ORSO82G5-1BM680I ² | 1 | PBGAM (With Heat Spreader) | 680 | I |

1. For all but the slowest commercial speed grade, the speed grades on these devices are dual marked. For example, the commercial speed grade -2XXXXXC is also marked with the industrial grade -1XXXXXI. The commercial grade is always one speed grade faster than the associated dual mark industrial grade. The slowest commercial speed grade is marked as commercial grade only.
2. BM680 package was converted to F680 via PCN#09A-08.

Lead-Free Packaging

Commercial¹

| Device Family | Part Number | Speed Grade | Package Type | Ball Count | Grade |
|---------------|-------------------|-------------|--|------------|-------|
| ORSO42G5 | ORSO42G5-3BMN484C | 3 | Lead-Free PBGAM | 484 | C |
| | ORSO42G5-2BMN484C | 2 | Lead-Free PBGAM | 484 | C |
| | ORSO42G5-1BMN484C | 1 | Lead-Free PBGAM | 484 | C |
| ORSO82G5 | ORSO82G5-3FN680C | 3 | Lead-Free FPGA (No Heat Spreader) ² | 680 | C |
| | ORSO82G5-2FN680C | 2 | Lead-Free FPGA (No Heat Spreader) ² | 680 | C |
| | ORSO82G5-1FN680C | 1 | Lead-Free FPGA (No Heat Spreader) ² | 680 | C |

1. For all the slowest commercial speed grade, the speed grades on these devices are dual marked. For example, the commercial speed grade -2XXXXXC is also marked with the industrial grade -1XXXXXI. The commercial grade is always one speed grade faster than the associated dual mark industrial grade. The slowest commercial speed grade is marked as commercial grade only.
2. Refer to the Thermal Management document at www.latticesemi.com for θ_{JA} and θ_{JC} information.

Industrial¹

| Device Family | Part Number | Speed Grade | Package Type | Ball Count | Grade |
|---------------|-------------------|-------------|--|------------|-------|
| ORSO42G5 | ORSO42G5-2BMN484I | 2 | Lead-Free PBGAM | 484 | I |
| | ORSO42G5-1BMN484I | 1 | Lead-Free PBGAM | 484 | I |
| ORSO82G5 | ORSO82G5-2FN680I | 2 | Lead-Free FPGA (No Heat Spreader) ² | 680 | I |
| | ORSO82G5-1FN680I | 1 | Lead-Free FPGA (No Heat Spreader) ² | 680 | I |

1. For all the slowest commercial speed grade, the speed grades on these devices are dual marked. For example, the commercial speed grade -2XXXXXC is also marked with the industrial grade -1XXXXXI. The commercial grade is always one speed grade faster than the associated dual mark industrial grade. The slowest commercial speed grade is marked as commercial grade only.
2. Refer to the Thermal Management document at www.latticesemi.com for θ_{JA} and θ_{JC} information.

Technical Support Assistance

Hotline: 1-800-LATTICE (North America)
+1-503-268-8001 (Outside North America)

e-mail: techsupport@latticesemi.com

Internet: www.latticesemi.com

Revision History

| Date | Version | Change Summary |
|-----------|---------|--|
| — | — | Previous Lattice releases. |
| July 2008 | 08.0 | BM680 conversion to F680 per PCN#09A-08. |