

Property of Lite-On Only

Features

- * Package in 12mm tape on 7" diameter reels.
- * Compatible with automatic placement equipment.
- * Compatible with infrared and vapor phase reflow solder process.
- * EIA STD package.
- * I.C. compatible.
- * Meet green product and Pb-free(According to RoHS)

Package Dimensions

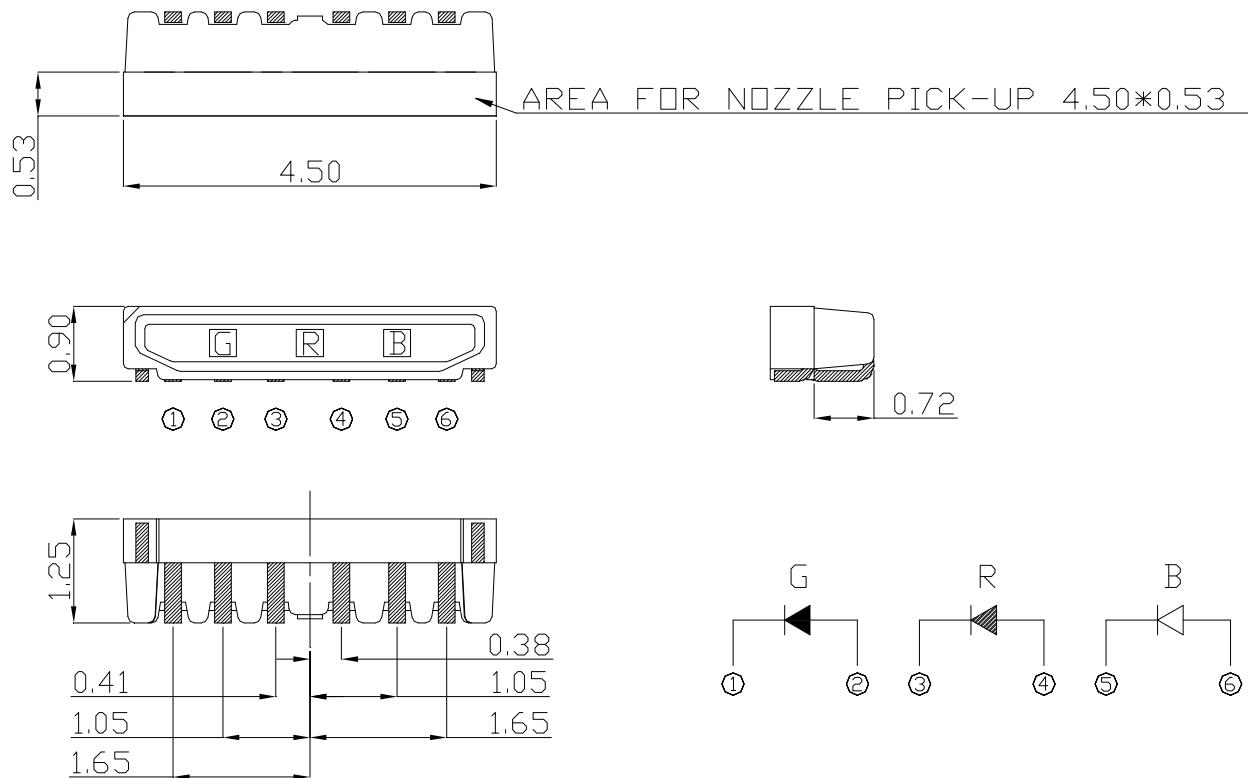

Coplanarity

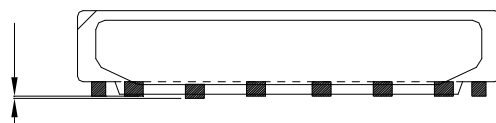

LSL: 0.00 mm (Lead is higher)

USL: 0.08 mm (PPA is higher)

Part No.	Lens Color	Source Color
LTW-008RGB2-PH1	White Diffused	InGaN Blue
		InGaN Green
		AllnGaP Red

Notes:

1. All dimensions are in millimeters (inches).
2. Tolerance is ± 0.1 mm (.004") unless otherwise noted.
3. Coplanarity: The stand-off from PPA to solder surface of leads is limited by USL: 0.08mm; LSL: 0.00mm means the solder surface of leads is higher 0.00mm or lower 0.08mm than PPA in limit.
4. The size of burr which is vertical to solder surface must lower than 0.08mm in limit.

Property of Lite-On Only

Absolute Maximum Ratings at Ta=25°C

Parameter	Symbol	Rating			Unit
		R	G	B	
Power Dissipation	P_o	75	120	120	mW
Peak Forward Current ¹	I_{FP}	100	100	100	mA
Continuous Forward Current	I_F	40	40	40	mA
Reverse Voltage	V_R	5			V
Operating Temperature Range	T_{opr}	-40 ~ +80			°C
Storage Temperature Range	T_{stg}	-40 ~ +100			°C
Soldering Condition ^{1,2}	T_{sol}	260°C For 5 Seconds			

Note: Operating the LED (in an application) under reverse bias condition might result in damage or failure of the component.

Suggestion IR Reflow Profile For Pb Free Process :

IR-Reflow Soldering Profile for lead free soldering (Acc. to J-STD-020D)

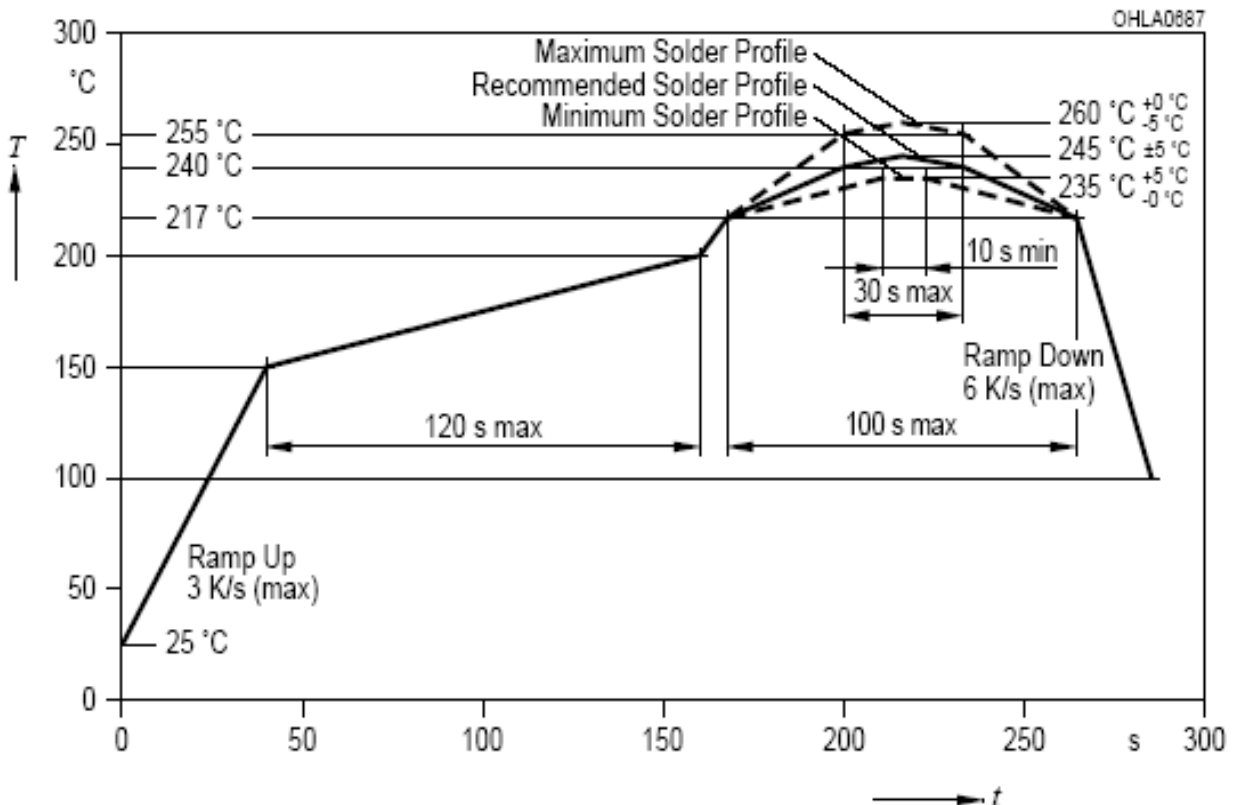

Property of Lite-On Only

Absolute Maximum Ratings at Ta=25°C

Parameter	Symbol	Values				Test Condition	Unit
			R	G	B		
Luminous Flux ¹	Φ_v	Min	1.60	3.90	0.41	R: $I_F = 25\text{mA}$ G: $I_F = 30\text{mA}$ B: $I_F = 15\text{mA}$	lm
		Typ.					
		Max.	3.40	8.47	0.99		
Viewing Angle	$2\theta_{1/2}$	Typ.	130			R: $I_F = 25\text{mA}$ G: $I_F = 30\text{mA}$ B: $I_F = 15\text{mA}$	°
Dominant Wavelength ²	λ_d	Min	618	517	455	R: $I_F = 25\text{mA}$ G: $I_F = 30\text{mA}$ B: $I_F = 15\text{mA}$	nm
		Typ.					
		Max.	629	532	465		
Color Coordinate	λ_d (Min)	Typ. x	0.6879	0.1317~ 0.2150	0.1555	R: $I_F = 25\text{mA}$ G: $I_F = 30\text{mA}$ B: $I_F = 15\text{mA}$	
		Typ. y	0.3115	0.6890	0.0283		
	λ_d (Max)	Typ. x	0.7055	0.0805~ 0.1825	0.1443		
		Typ. y	0.2940	0.7850	0.0461		
Peak Wavelength	λ_p	Min				R: $I_F = 25\text{mA}$ G: $I_F = 30\text{mA}$ B: $I_F = 15\text{mA}$	nm
		Typ.	628	523	458		
		Max.					
Forward Voltage ³	V_F	Min	1.8	3.1	2.6	R: $I_F = 25\text{mA}$ G: $I_F = 30\text{mA}$ B: $I_F = 15\text{mA}$	V
		Typ.	2.2	3.4	3.0		
		Max.	2.5	3.6	3.4		
Reverse Current	I_R	Max.	10			$V_R = 5\text{V}$	μA
Spectrum Radiation Bandwidth	$\Delta\lambda$	Typ.	20	33	22	R: $I_F = 25\text{mA}$ G: $I_F = 30\text{mA}$ B: $I_F = 15\text{mA}$	nm

Note :

1. Tolerance of Luminous Intensity +/- 10%
2. Tolerance of Dominant Wavelength +/- 1nm
3. Tolerance of Forward Voltage +/- 0.1V
4. Caution in ESD:

Static Electricity and surge damages the LED. It is recommend to use a wrist band or anti-electrostatic glove when handling the LED. All devices, equipment and machinery must be properly grounded.

5. CAS140B is the test standard for the chromaticity coordinates IV.

Property of Lite-On Only

Bin Code List

Luminous Spec. Table		
Ranks	Luminous Flux (lm)	
	$I_F: R=25mA, G=30mA, B=15mA$	
	Min.	Max.
W0	5.91	6.41
W1	6.41	7.05
W2	7.05	7.76
W3	7.76	8.53
W4	8.53	9.38

Tolerance on each Luminous Intensity bin is +/- 10%

Color Ranks Table											
Ranks	Color bin limits				Ranks	Color bin limits					
	$I_F: R=25mA, G=30mA, B=15mA$					$I_F: R=25mA, G=30mA, B=15mA$					
H4	x	0.2431	0.2563	0.2563	0.2431	J4	x	0.2563	0.2694	0.2694	0.2563
	y	0.2142	0.2186	0.2274	0.2230		y	0.2186	0.2230	0.2318	0.2274
H5	x	0.2431	0.2563	0.2563	0.2431	J5	x	0.2563	0.2694	0.2694	0.2563
	y	0.2229	0.2273	0.2361	0.2317		y	0.2273	0.2317	0.2405	0.2361
H6	x	0.2431	0.2563	0.2563	0.2431	J6	x	0.2563	0.2694	0.2694	0.2563
	y	0.2317	0.2361	0.2448	0.2404		y	0.2361	0.2405	0.2492	0.2448
H7	x	0.2431	0.2563	0.2563	0.2431	J7	x	0.2563	0.2694	0.2694	0.2563
	y	0.2404	0.2448	0.2536	0.2492		y	0.2448	0.2492	0.2580	0.2536
H8	x	0.2431	0.2563	0.2563	0.2431	J8	x	0.2563	0.2694	0.2694	0.2563
	y	0.2492	0.2536	0.2623	0.2579		y	0.2536	0.2580	0.2667	0.2623
H9	x	0.2431	0.2563	0.2563	0.2431	J9	x	0.2563	0.2694	0.2694	0.2563
	y	0.2579	0.2623	0.2711	0.2667		y	0.2623	0.2667	0.2755	0.2711
K4	x	0.2694	0.2825	0.2825	0.2694	L4	x	0.2825	0.2956	0.2956	0.2825
	y	0.2230	0.2274	0.2361	0.2318		y	0.2274	0.2317	0.2405	0.2361
K5	x	0.2694	0.2825	0.2825	0.2694	L5	x	0.2825	0.2956	0.2956	0.2825
	y	0.2317	0.2361	0.2448	0.2405		y	0.2361	0.2404	0.2492	0.2448
K6	x	0.2694	0.2825	0.2825	0.2694	L6	x	0.2825	0.2956	0.2956	0.2825
	y	0.2405	0.2448	0.2536	0.2492		y	0.2448	0.2492	0.2579	0.2536
K7	x	0.2694	0.2825	0.2825	0.2694	L7	x	0.2825	0.2956	0.2956	0.2825
	y	0.2492	0.2536	0.2623	0.2580		y	0.2536	0.2579	0.2667	0.2623
K8	x	0.2694	0.2825	0.2825	0.2694	L8	x	0.2825	0.2956	0.2956	0.2825
	y	0.2580	0.2623	0.2711	0.2667		y	0.2623	0.2667	0.2754	0.2711

Property of Lite-On Only

Bin Code List

Color Ranks Table											
Ranks	Color bin limits					Ranks	Color bin limits				
	$I_F: R=25mA, G=30mA, B=15mA$						$I_F: R=25mA, G=30mA, B=15mA$				
K9	x	0.2694	0.2825	0.2825	0.2694	L9	x	0.2825	0.2956	0.2956	0.2825
	y	0.2667	0.2711	0.2798	0.2755		y	0.2711	0.2754	0.2842	0.2798
M4		0.2956	0.3087	0.3087	0.2956	N4		0.3087	0.3218	0.3218	0.3087
		0.2317	0.2361	0.2448	0.2405			0.2361	0.2404	0.2492	0.2449
M5	x	0.2956	0.3087	0.3087	0.2956	N5	x	0.3087	0.3218	0.3218	0.3087
	y	0.2404	0.2448	0.2535	0.2492		y	0.2448	0.2491	0.2579	0.2536
M6	x	0.2956	0.3087	0.3087	0.2956	N6	x	0.3218	0.3087	0.3087	0.3218
	y	0.2492	0.2535	0.2623	0.2579		y	0.2579	0.2536	0.2623	0.2666
M7	x	0.2956	0.3087	0.3087	0.2956	N7	x	0.3087	0.3218	0.3218	0.3087
	y	0.2579	0.2623	0.2710	0.2667		y	0.2623	0.2666	0.2754	0.2711
M8	x	0.3087	0.2956	0.2956	0.3087	N8	x	0.3218	0.3087	0.3087	0.3218
	y	0.2710	0.2667	0.2754	0.2798		y	0.2754	0.2711	0.2798	0.2841
M9	x	0.2956	0.3087	0.3087	0.2956	N9	x	0.3087	0.3218	0.3218	0.3087
	y	0.2754	0.2798	0.2885	0.2842		y	0.2798	0.2841	0.2929	0.2886

Tolerance on each Hue bin (x, y) bin is +/- 0.01.

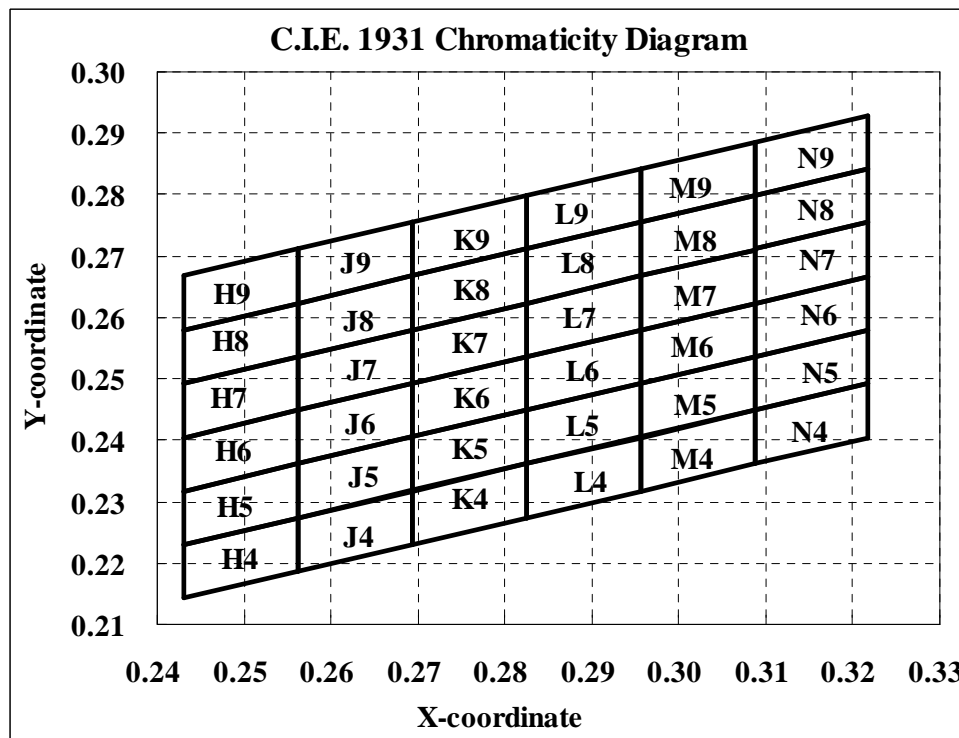

Property of Lite-On Only

Shipping Label Code List

Shipping Label Code						
		Luminous Flux Ranks				
		W0	W1	W2	W3	W4
Color Ranks	H4	A1	B1	C1	D1	E1
	H5	A2	B2	C2	D2	E2
	H6	A3	B3	C3	D3	E3
	H7	A4	B4	C4	D4	E4
	H8	A5	B5	C5	D5	E5
	H9	A6	B6	C6	D6	E6
	J4	A7	B7	C7	D7	E7
	J5	A8	B8	C8	D8	E8
	J6	A9	B9	C9	D9	E9
	J7	A10	B10	C10	D10	E10
	J8	A11	B11	C11	D11	E11
	J9	A12	B12	C12	D12	E12
	K4	A13	B13	C13	D13	E13
	K5	A14	B14	C14	D14	E14
	K6	A15	B15	C15	D15	E15
	K7	A16	B16	C16	D16	E16
	K8	A17	B17	C17	D17	E17
	K9	A18	B18	C18	D18	E18
	L4	A19	B19	C19	D19	E19
	L5	A20	B20	C20	D20	E20
	L6	A21	B21	C21	D21	E21
	L7	A22	B22	C22	D22	E22
	L8	A23	B23	C23	D23	E23
	L9	A24	B24	C24	D24	E24
	M4	A25	B25	C25	D25	E25
	M5	A26	B26	C26	D26	E26
	M6	A27	B27	C27	D27	E27
	M7	A28	B28	C28	D28	E28
	M8	A29	B29	C29	D29	E29
	M9	A30	B30	C30	D30	E30
	N4	A31	B31	C31	D31	E31
	N5	A32	B32	C32	D32	E32
	N6	A33	B33	C33	D33	E33
	N7	A34	B34	C34	D34	E34
	N8	A35	B35	C35	D35	E35
	N9	A36	B36	C36	D36	E36

Property of Lite-On Only

Typical Electrical / Optical Characteristics Curve

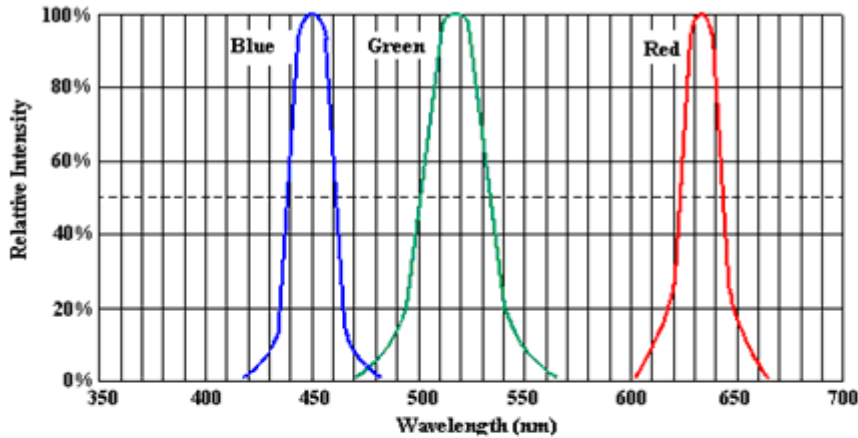

Fig.1 Relative Intensity vs Dominant Wavelength

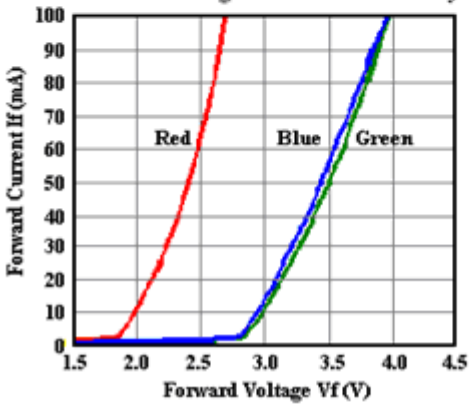

Fig.2 Forward Current vs Forward Voltage

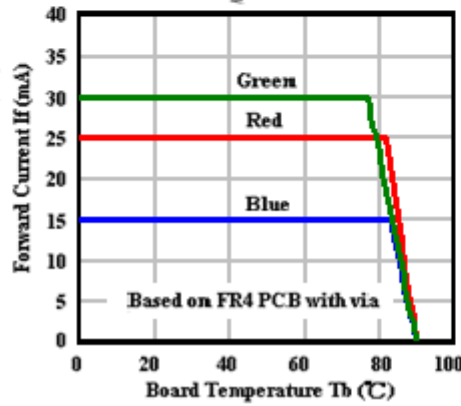
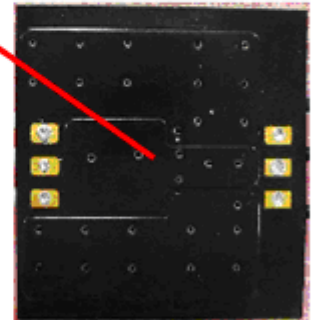
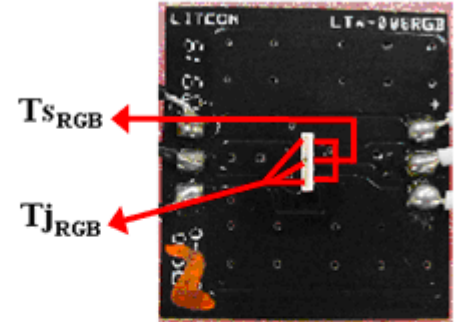

Fig.3 Forward Current Derating Curve



T_s : Soldering Pin Temperature
 T_j : Junction Temperature
 T_b : Board Temperature

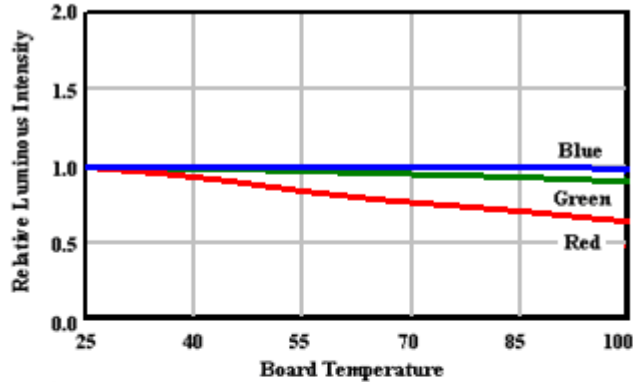

Fig.5 Luminous Intensity vs Board Temperature
(The characteristic curve are the same as R, G and B chip lighting up simultaneously)

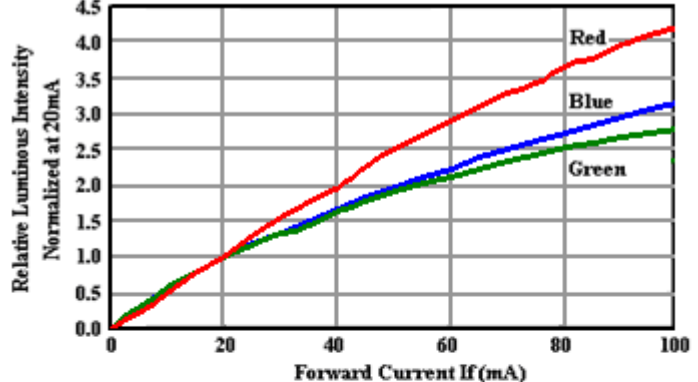

Fig.4 Relative Luminous Intensity vs Forward Current

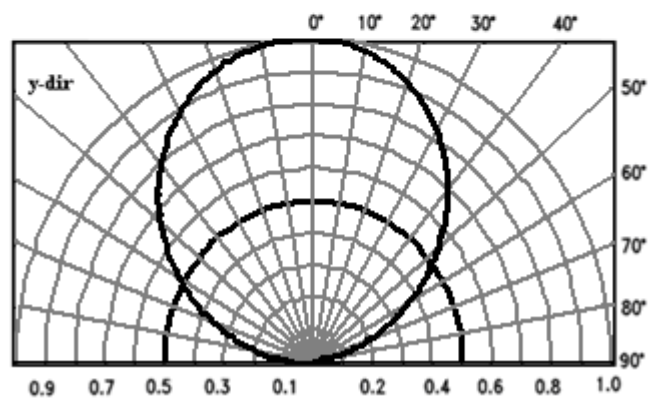
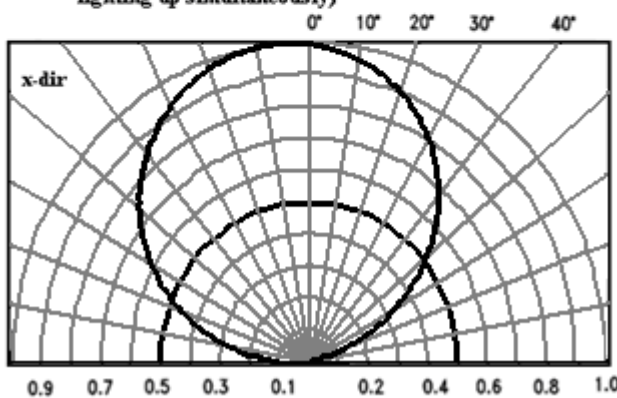

Fig.6 Spatial Distribution

Property of Lite-On Only

User Guide

Cleaning

Do not use unspecified chemical liquid to clean LED they could harm the package.
If cleaning is necessary, immerse the LED in ethyl alcohol or isopropyl alcohol at normal temperature for less one minute.

Recommend Printed Circuit Board Attachment Pad

Infrared / vapor phase

Reflow Soldering

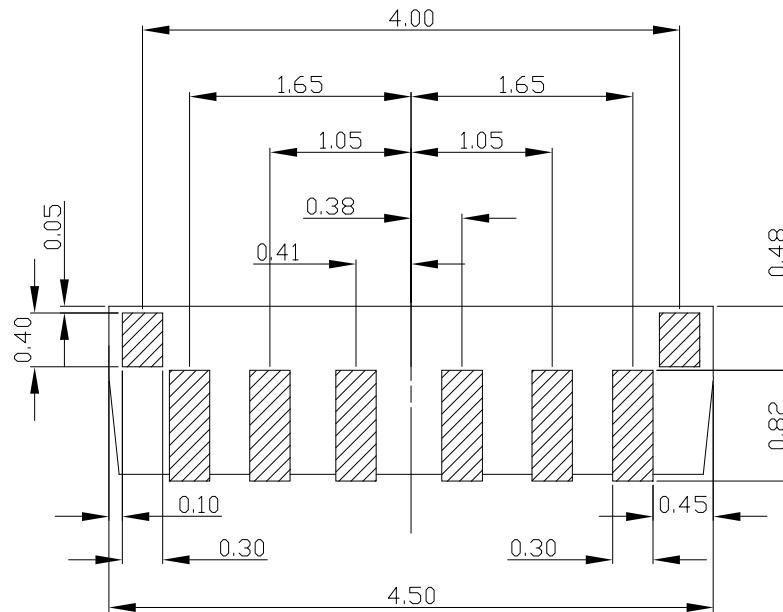

Package Dimensions of Tape

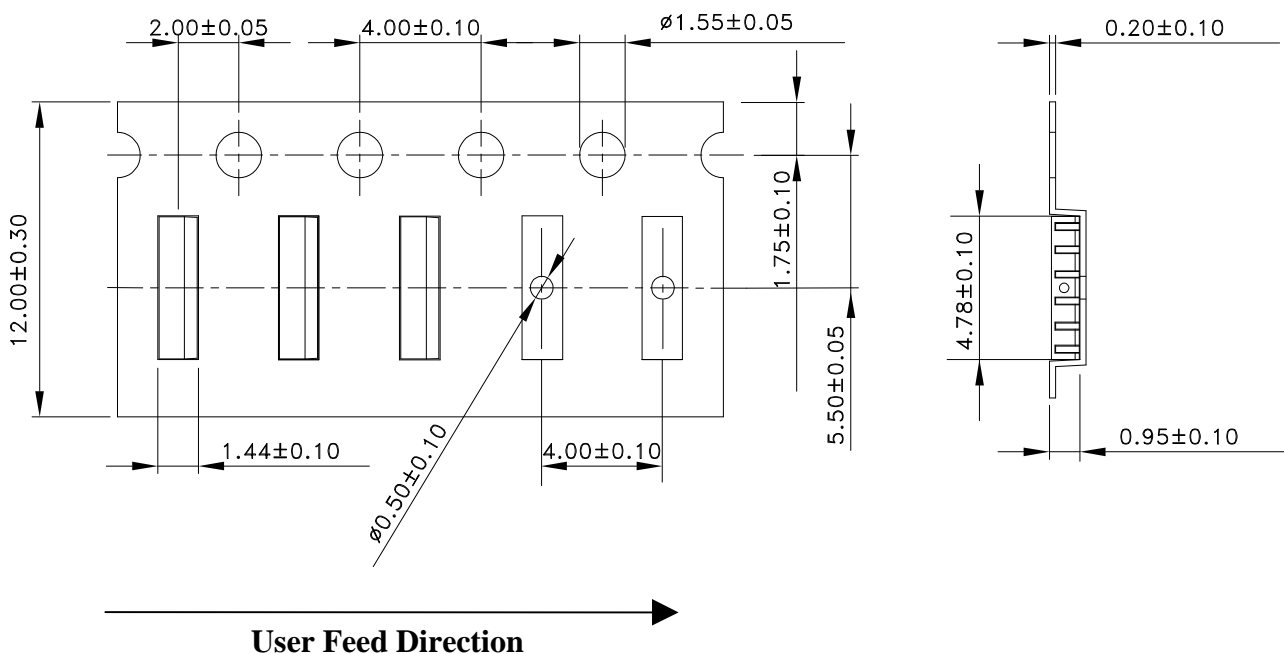

Property of Lite-On Only

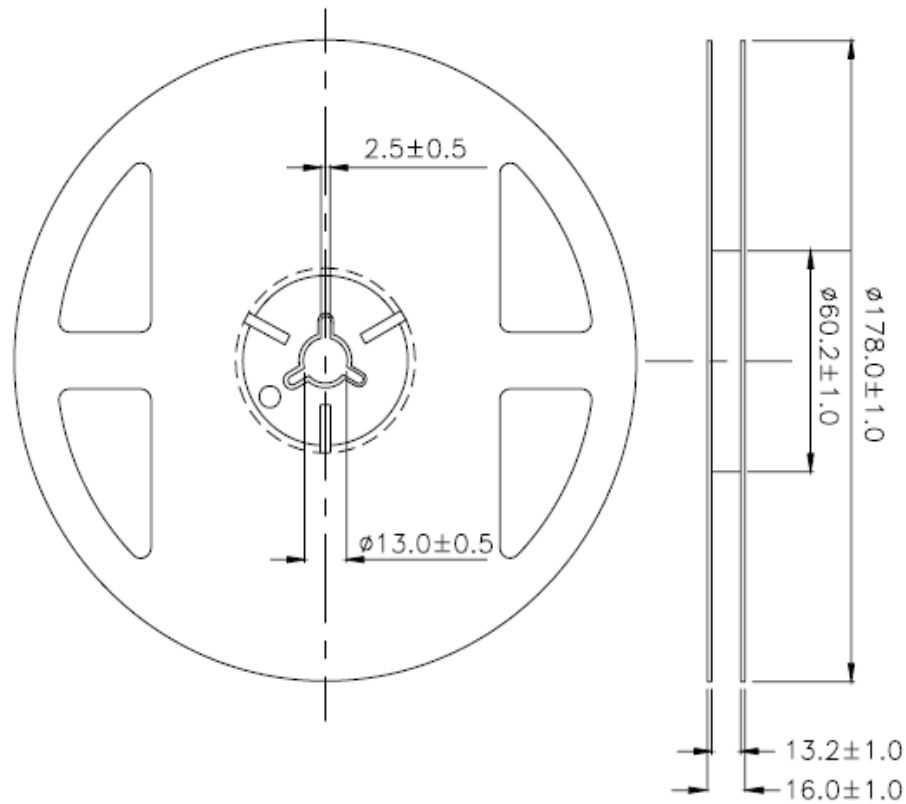
Package Dimensions of Reel

Note: Tolerances Unless Dimension $\pm 0.1\text{mm}$,Unit = mm

The material of reel was PC.

Notes:

1. Empty component pockets sealed with top cover tape.
2. 7 inch reel-2000 pieces per reel.
3. The maximum number of consecutive missing lamps is two.
4. In accordance with EIA-481-1-B specifications.

CAUTIONS

1. Application

The LEDs described here are intended to be used for ordinary electronic equipment (such as office equipment, communication equipment and household applications). Consult Liteon's Sales in advance for information on applications in which exceptional reliability is required, particularly when the failure or malfunction of the LEDs may directly jeopardize life or health (such as in aviation, transportation, traffic control equipment, medical and life support systems and safety devices).

2. Storage

This product is qualified as Moisture sensitive Level 3 per JEDEC J-STD-020 Precaution when handling this moisture sensitive product is important to ensure the reliability of the product.

The package is sealed:

The LEDs should be stored at 30°C or less and 90%RH or less. And the LEDs are limited to use within one year, while the LEDs is packed in moisture-proof package with the desiccants inside.

The package is opened:

The LEDs should be stored at 30°C or less and 60%RH or less. Moreover, the LEDs are limited to solder process within 168hrs. If the Humidity Indicator shows the pink color in 10% even higher or exceed the storage limiting time since opened, that we recommended to baking LEDs at 60°C at least 48hrs. To seal the remainder LEDs return to package, it's recommended to be with workable desiccants in original package.

3. Cleaning

Use alcohol-based cleaning solvents such as isopropyl alcohol to clean the LED if necessary.

4. Soldering

Recommended soldering conditions:

Reflow soldering		Soldering iron	
Pre-heat	120~150°C	Temperature	300°C Max.
Pre-heat time	120 sec. Max.	Soldering time	3 sec. Max.
Soldering Temp.	260°C Max.		(one time only)
Soldering time	30 sec. Max.		

5. Drive Method

An LED is a current-operated device. In order to ensure intensity uniformity on multiple LEDs connected in parallel in an application, it is recommended that a current limiting resistor be incorporated in the drive circuit, in series with each LED as shown in Circuit A below.

Circuit model A

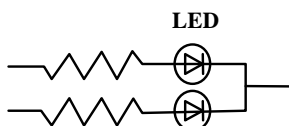

(A) Recommended circuit.

Circuit model B

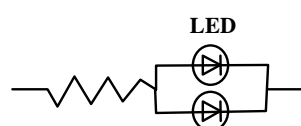

(B) The brightness of each LED might appear different due to the differences in the I-V characteristics of those LEDs.

Property of Lite-On Only

6. ESD (Electrostatic Discharge)

Static Electricity or power surge will damage the LED.

Suggestions to prevent ESD damage:

- Use of a conductive wrist band or anti-electrostatic glove when handling these LEDs.
 - All devices, equipment, and machinery must be properly grounded.
 - Work tables, storage racks, etc. should be properly grounded.
 - Use ion blower to neutralize the static charge which might have built up on surface of the LED's plastic lens as a result of friction between LEDs during storage and handling.
- ESD-damaged LEDs will exhibit abnormal characteristics such as high reverse leakage current, low forward Voltage, or "no light-up" at low currents.

To verify for ESD damage, check for "light up" and Vf of the suspect LEDs at low currents.

The Vf of "good" LEDs should be $>2.0V@0.1mA$ for InGaN product.

7. Reliability Test

ITEM	TEST ITEM	CONDITION	DURATION	SAMPLE SIZE
P1	Resistance to soldering heat (RTSH) JEITA ED-4701 300 301	IR soldering according attached lead free (Refer to J-STD-020D.1)	10sec/3x	3lots*30
P2	Temperature cycle (TC)	-20~25~85'C/ 30min each (20mins trans)	2500cycles	3lots*30
P3	Steady state life test(SSLT)	Ta=60'C If (RGB)=25/30/15mA	20000hrs	3lots*30
P4	Pulse life test(PLT)	Ta=60'C If (RGB)= 25/30/15mA	20000hrs	3lots*30

8. Suggested Checking List

Training and Certification

1. Everyone working in a static-safe area is ESD-certified?
2. Training records kept and re-certification dates monitored?

Static-Safe Workstation & Work Areas

1. Static-safe workstation or work-areas have ESD signs?
2. All surfaces and objects at all static-safe workstation and within 1 ft measure less than 100V?
3. All ionizer activated, positioned towards the units?
4. Each work surface mats grounding is good?

Personnel Grounding

1. Every person (including visitors) handling ESD sensitive (ESDS) items wear wrist strap, heel strap or conductive shoes with conductive flooring?
2. If conductive footwear used, conductive flooring also present where operator stand or walk?
3. Garments, hairs or anything closer than 1 ft to ESD items measure less than 100V*?
4. Every wrist strap or heel strap/conductive shoes checked daily and result recorded for all DLs?
5. All wrist strap or heel strap checkers calibration up to date?

Note: *50V for Blue LED.

Device Handling

1. Every ESDS items identified by EIA-471 labels on item or packaging?
2. All ESDS items completely inside properly closed static-shielding containers when not at static-safe workstation?
3. No static charge generators (e.g. plastics) inside shielding containers with ESDS items?
4. All flexible conductive and dissipative package materials inspected before reuse or recycle?

Others

1. Audit result reported to entity ESD control coordinator?
2. Corrective action from previous audits completed?
3. Are audit records complete and on file?

Property of Lite-On Only

Version	Page	Content of Change	Date Record
A	1	The package layout changed.	2010/05/05
B	3, 4	1. Red min. lumen spec modify from 1.61 to 1.70 2. White min. lumen spec modify form 6.32 to 6.41 (Based on Red min lumen modify) 3. Green max. Vf spec modify from 3.6 to 3.55	2010/05/07
C	1, 6, 7	1. New design solder pin of lead frame modify. 2. Typical electrical / optical characteristics curves modify.	2010/07/13
D	3, 4, 5	Luminous flux and color spec modify.	2010/08/24
E	1, 3, 10	1. Add the dimensions of pick-up area. 2. Green max. Vf spec modify from 3.65 to 3.55 3. Duration time for RA test modify. (follow 2K10)	2010/10/22
F	6	Add shipping label code list	2010/12/08
G	4, 5, 6	Color spec modify	2011/01/24
H	3	Green max. Vf spec modify from 3.55 to 3.6	2012/05/08