

**HF** **RoHS** **Pb** **GREEN** **SP6001 Lead-Free/Green Series**

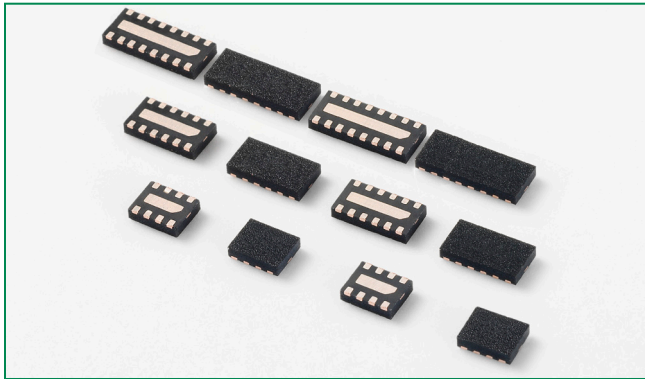

**Description**

The Littelfuse SP6001 SPA series integrates 4, 6 and 8 EMI filters (C-R-C) into a small, low-profile UDFN package with each filter providing greater than -30dB attenuation at 1GHz. Additionally, each I/O is capable of shunting ±30kV ESD strikes (IEC61000-4-2, contact discharge) away from sensitive electronic components. The performance of this small, slim design makes it extremely suitable for mobile handsets, PDAs and notebook computers.

**Pinout**

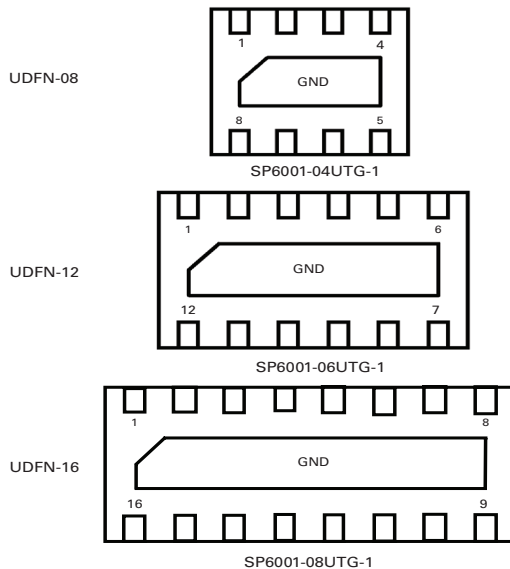

**Features**

- EMI filtering of frequencies from 800MHz to 3GHz
- Greater than -30dB attenuation (TYP) at 1GHz
- ESD, IEC61000-4-2, ±30kV contact, ±30kV air
- Small, low-profile UDFN package (TYP 0.5mm height)

**Functional Block Diagram**

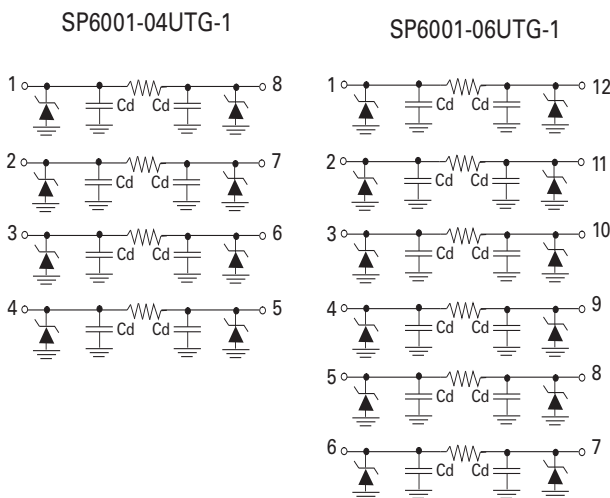

**Applications**

- Keypad interface for portable electronics
- LCD and camera display interfaces for handsets
- Connector interfaces for portable electronics
- Mobile phone
- Smartphone
- Portable navigation device

Lead-Free/Green SP6001

### Absolute Maximum Ratings

Symbol	Parameter	Value	Units
T <sub>OP</sub>	Operating Temperature	-40 to 85	°C
T <sub>STOR</sub>	Storage Temperature	-60 to 150	°C

CAUTION: Stresses above those listed in "Absolute Maximum Ratings" may cause permanent damage to the device. This is a stress only rating and operation of the device at these or any other conditions above those indicated in the operational sections of this specification is not implied.

### Thermal Information

Parameter	Rating	Units
Storage Temperature Range	-65 to 150	°C
Maximum Junction Temperature	150	°C
Maximum Lead Temperature (Soldering 10s)	260	°C

### Electrical Characteristics (T<sub>OP</sub>=25°C)

Parameter	Symbol	Test Conditions	Min	Typ	Max	Units
Reverse Standoff Voltage	V <sub>RWM</sub>				6.0	V
Breakdown Voltage	V <sub>BR</sub>	I <sub>R</sub> =1mA	7.0	7.8	8.5	V
Reverse Leakage Current	I <sub>LEAK</sub>	V <sub>RWM</sub> =5V		0.1	1.0	μA
Resistance	R <sub>A</sub>	I <sub>R</sub> =10mA	85	100	115	Ω
Diode Capacitance <sup>1,2</sup>	C <sub>D</sub>	V <sub>R</sub> =2.5V,f=1MHz		12		pF
Line Capacitance <sup>1,2</sup>	C <sub>L</sub>	V <sub>R</sub> =2.5V,f=1MHz	19	24	29	pF
ESD Withstand Voltage <sup>1</sup>	V <sub>ESD</sub>	IEC61000-4-2 (Contact Discharge)	±30			kV
		IEC61000-4-2 (Air Discharge)	±30			kV
Cutoff Frequency <sup>3</sup>	F <sub>-3dB</sub>	Above this frequency, appreciable attenuation occurs		115		MHz

Notes: <sup>1</sup> Parameter is guaranteed by design and/or device characterization.

<sup>2</sup> Total line capacitance is two times the diode capacitance (C<sub>D</sub>).

<sup>3</sup> 50Ω source and 50Ω load termination

**Insertion Loss (S21)**

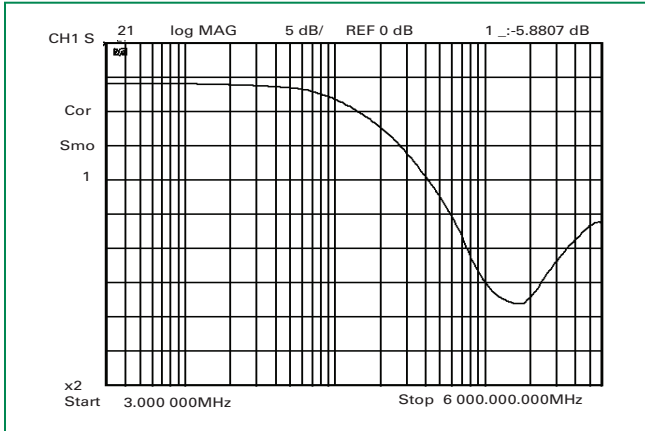

**Analog Crosstalk (S41)**

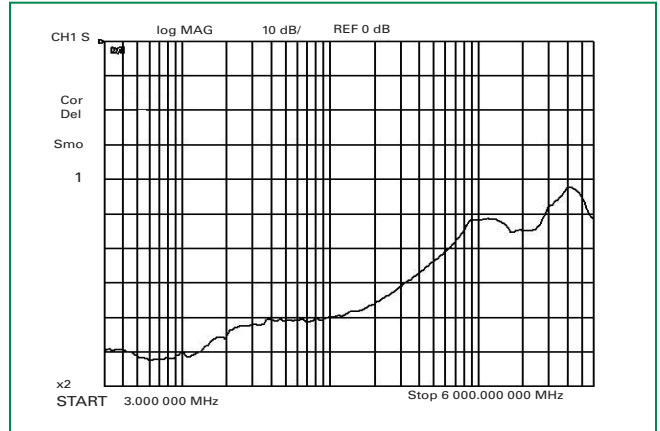

**Line Capacitance vs. DC Bias**

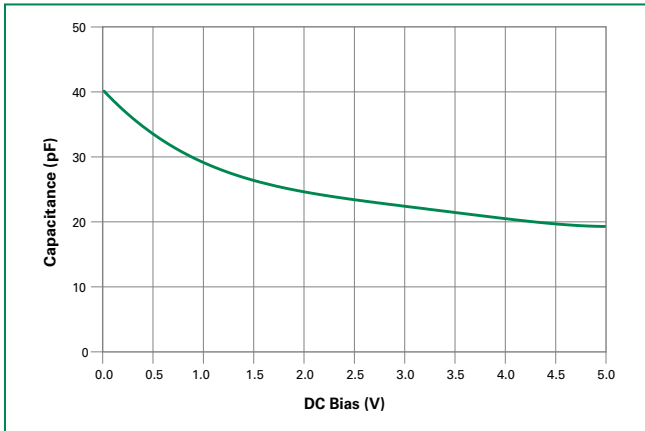

Lead-Free/Green SP6001

Application Example

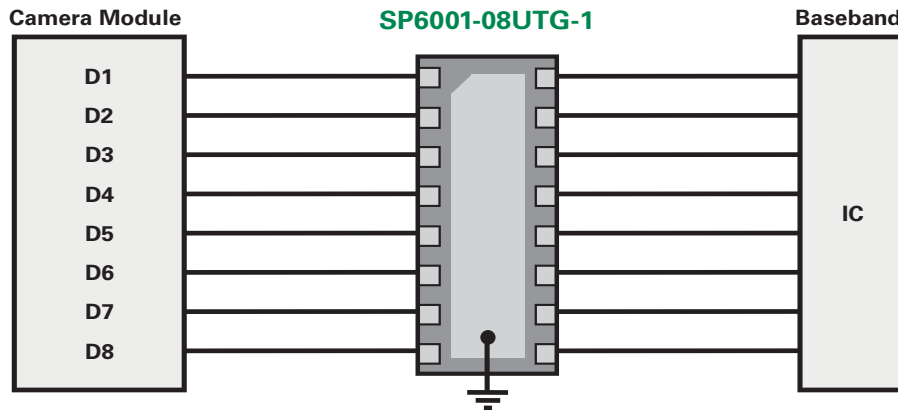
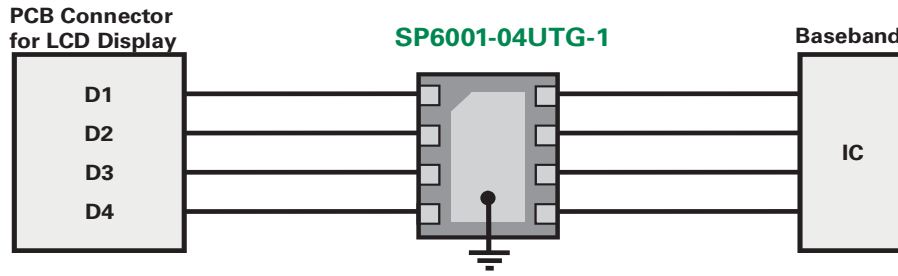

Soldering Parameters

Reflow Condition		Pb – Free assembly
Pre Heat	- Temperature Min ( $T_{s(min)}$ )	150°C
	- Temperature Max ( $T_{s(max)}$ )	200°C
	- Time (min to max) ( $t_s$ )	60 – 180 secs
Average ramp up rate (Liquidus Temp ( $T_L$ ) to peak)		3°C/second max
$T_{s(max)}$ to $T_L$ - Ramp-up Rate		3°C/second max
Reflow	- Temperature ( $T_L$ ) (Liquidus)	217°C
	- Temperature ( $t_L$ )	60 – 150 seconds
Peak Temperature ( $T_p$ )		250 <sup>+0/-5</sup> °C
Time within 5°C of actual peak Temperature ( $t_p$ )		20 – 40 seconds
Ramp-down Rate		6°C/second max
Time 25°C to peak Temperature ( $T_p$ )		8 minutes Max.
Do not exceed		260°C

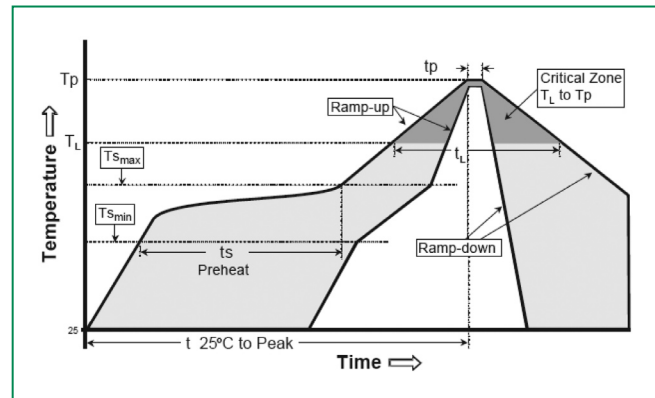

**Package Dimensions - UDFN-08**

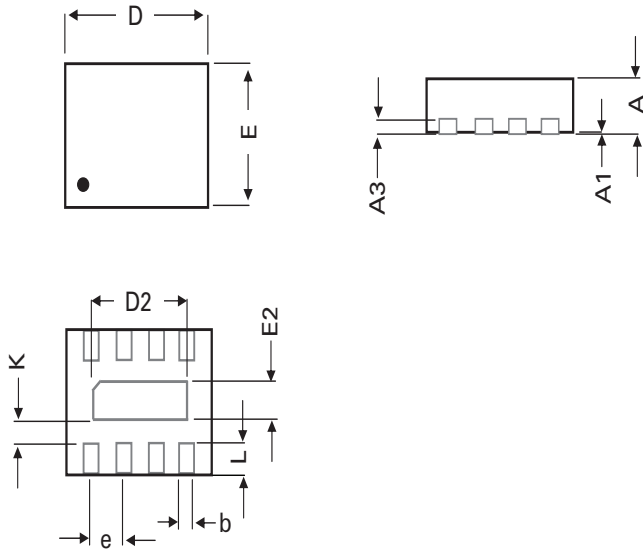

Symbol	UDFN-08			
	Millimeters		Inches	
	Min	Max	Min	Max
<b>A</b>	0.450	0.550	0.018	0.022
<b>A1</b>	0.000	0.050	0.000	0.002
<b>A3</b>	0.127 REF		0.005 REF	
<b>b</b>	0.150	0.250	0.006	0.010
<b>D</b>	1.600	1.800	0.063	0.071
<b>D2</b>	1.100	1.300	0.043	0.051
<b>E</b>	1.250	1.450	0.049	0.057
<b>E2</b>	0.300	0.500	0.012	0.020
<b>e</b>	0.400 BSC		0.016 BSC	
<b>K</b>	0.200		0.008	0.000
<b>L</b>	0.150	0.350	0.006	0.014

**Package Dimensions - UDFN-12**

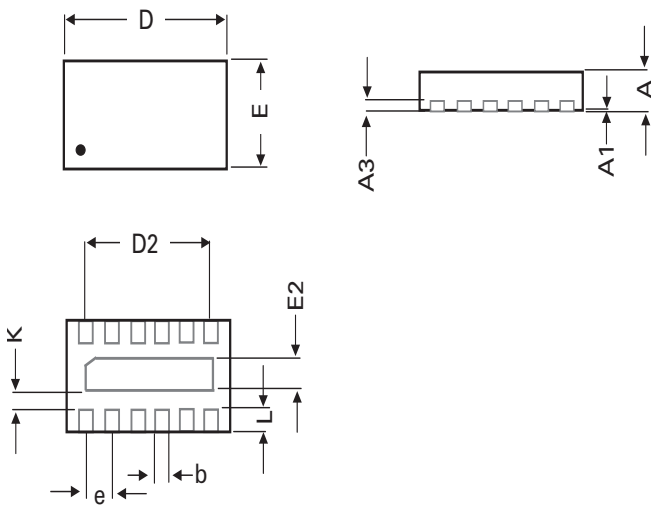

Symbol	UDFN-12			
	Millimeters		Inches	
	Min	Max	Min	Max
<b>A</b>	0.450	0.550	0.018	0.022
<b>A1</b>	0.000	0.050	0.000	0.002
<b>A3</b>	0.127 REF		0.005 REF	
<b>b</b>	0.150	0.250	0.006	0.010
<b>D</b>	2.400	2.600	0.094	0.102
<b>D2</b>	1.900	2.100	0.075	0.083
<b>E</b>	1.250	1.450	0.049	0.057
<b>E2</b>	0.300	0.500	0.012	0.020
<b>e</b>	0.400 BSC		0.016 BSC	
<b>K</b>	0.200		0.008	0.000
<b>L</b>	0.150	0.350	0.006	0.014

Lead-Free/Green SP6001

### Package Dimensions - UDFN-16

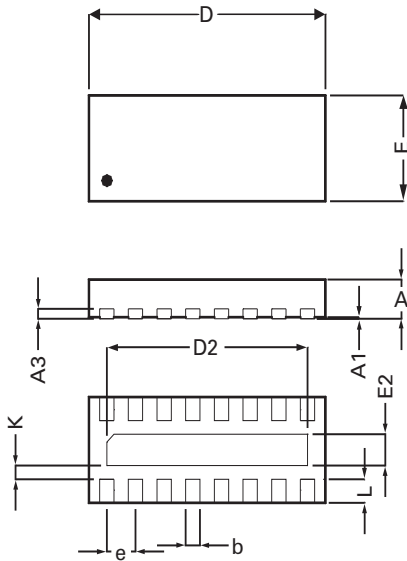

Symbol	UDFN-16			
	Millimeters		Inches	
	Min	Max	Min	Max
<b>A</b>	0.45	0.55	0.01	0.02
<b>A1</b>	0.00	0.05	0.00	0.00
<b>A3</b>	0.127 REF		0.00 REF	
<b>b</b>	0.15	0.25	0.00	0.00
<b>D</b>	3.20	3.40	0.12	0.13
<b>D2</b>	2.70	2.90	0.10	0.11
<b>E</b>	1.25	1.45	0.04	0.05
<b>E2</b>	0.30	0.50	0.01	0.01
<b>e</b>	0.40 BSC		0.01 BSC	
<b>K</b>	0.20		0.00	
<b>L</b>	0.15	0.35	0.00	0.01

### Part Numbering System

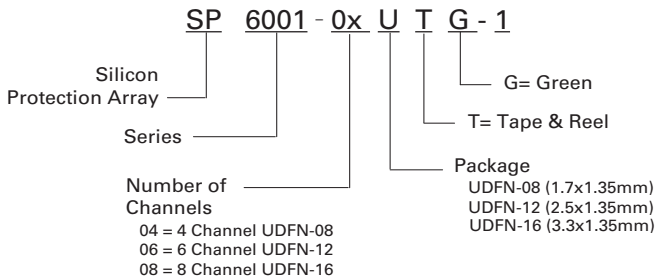

### Product Characteristics

<b>Lead Plating</b>	Pre-Plated Frame
<b>Lead Material</b>	Copper Alloy
<b>Lead Coplanarity</b>	0.0004 inches (0.102mm)
<b>Substitute Material</b>	Silicon
<b>Body Material</b>	Molded Epoxy
<b>Flammability</b>	UL94-V0

#### Notes :

- All dimensions are in millimeters
- Dimensions include solder plating.
- Dimensions are exclusive of mold flash & metal burr.
- All specifications comply to JEDEC SPEC MO-223 Issue A
- Blo is facing up for mold and facing down for trim/form, i.e. reverse trim/form.
- Package surface matte finish VDI 11-13.

### Part Marking System

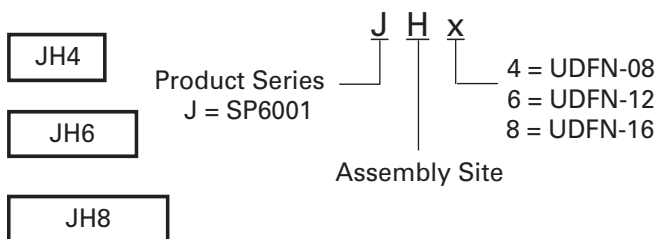

### Ordering Information

Part Number	Package	Size	Marking	Min. Order Qty.
SP6001-04UTG-1	uDFN-08	1.7x1.35mm	JH4	3000
SP6001-06UTG-1	uDFN-12	2.5x1.35mm	JH6	3000
SP6001-08UTG-1	uDFN-16	3.3x1.35mm	JH8	3000

**Embossed Carrier Tape & Reel Specification – UDFN-08**

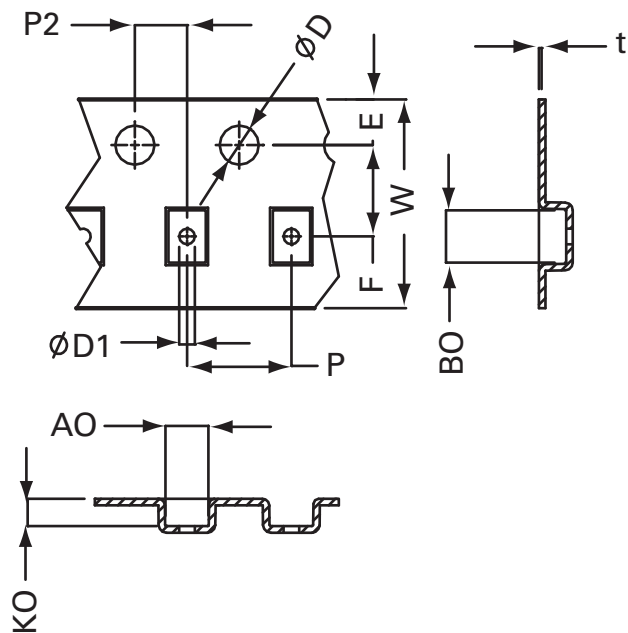

Symbol	Millimetres		Inches	
	Min	Max	Min	Max
<b>E</b>	1.65	1.85	0.065	0.073
<b>F</b>	3.45	3.55	0.136	0.140
<b>D1</b>	1.00	-	0.040	-
<b>D</b>	1.50 min		0.059 min	
<b>P</b>	3.90	4.10	0.154	0.161
<b>10P</b>	40.0 +/- 0.20		1.575 +/- 0.008	
<b>W</b>	7.70	8.30	0.303	0.327
<b>P2</b>	1.95	2.05	0.077	0.081
<b>A0</b>	1.55	1.75	0.061	0.069
<b>B0</b>	1.90	2.1	0.075	0.083
<b>K0</b>	0.95	1.15	0.037	0.045
<b>t</b>	0.30 max		0.012 max	

**Embossed Carrier Tape & Reel Specification – UDFN-12**

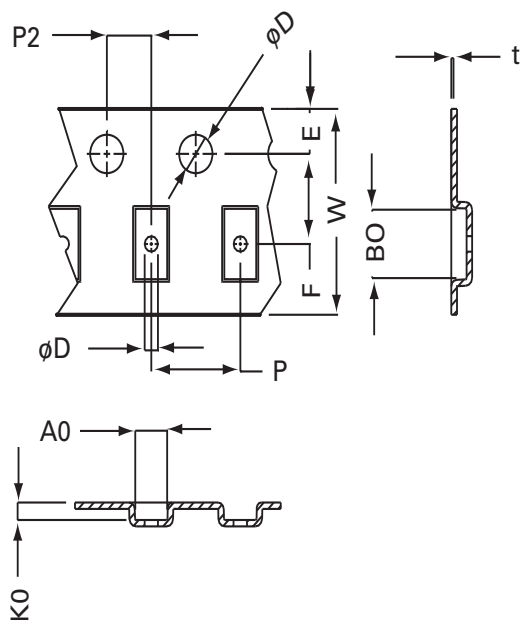

Symbol	Millimetres		Inches	
	Min	Max	Min	Max
<b>E</b>	1.65	1.85	0.065	0.073
<b>F</b>	3.45	3.55	0.136	0.140
<b>D1</b>	0.55	0.65	0.021	0.025
<b>D</b>	1.50 min		0.059 min	
<b>P</b>	3.90	4.10	0.154	0.161
<b>10P</b>	40.0 +/- 0.20		1.575 +/- 0.008	
<b>W</b>	7.90	8.30	0.311	0.327
<b>P2</b>	1.95	2.05	0.077	0.081
<b>A0</b>	1.33	1.53	0.052	0.060
<b>B0</b>	2.63	2.83	0.103	0.111
<b>K0</b>	0.58	0.78	0.023	0.031
<b>t</b>	0.22 max		0.009 max	

Lead-Free/Green SP6001

**Embossed Carrier Tape & Reel Specification – UDFN-16**

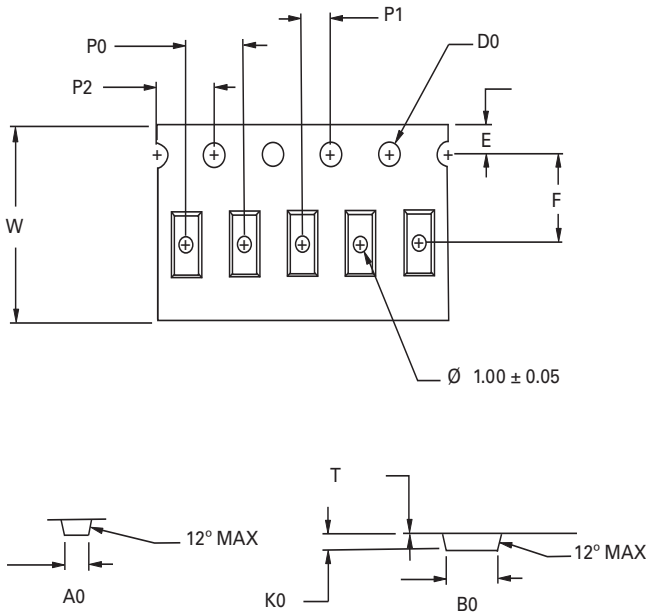

Symbol	Millimetres		Inches	
	Min	Max	Min	Max
<b>A0</b>	1.55	1.75	0.06	0.06
<b>B0</b>	3.50	3.70	0.13	0.14
<b>D0</b>	1.40	1.60	0.05	0.06
<b>E</b>	1.65	1.85	0.06	0.07
<b>F</b>	5.45	5.55	0.21	0.21
<b>K0</b>	0.85	1.05	0.03	0.04
<b>P0</b>	3.90	4.10	0.15	0.16
<b>P1</b>	1.95	2.05	0.07	0.08
<b>P2</b>	3.90	4.10	0.15	0.16
<b>T</b>	0.26	0.30	0.01	0.01
<b>W</b>	11.90	12.30	0.46	0.48