

UNCONTROLLED DOCUMENT

PART NUMBER		REV.
SML-LX1610SIC/A		A
REV.	E.C.N. NUMBER AND REVISION COMMENTS	DATE
A	E.C.N. #11391.	01.16.07

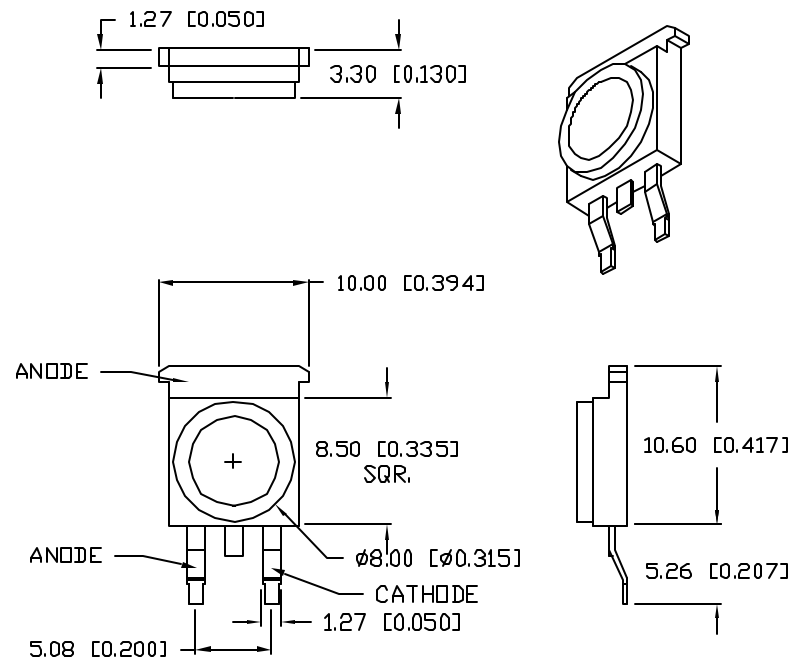

ELECTRO-OPTICAL CHARACTERISTICS  $T_A=25^{\circ}\text{C}$   $I_f=350\text{mA}$

PARAMETER	SYMBOL	MIN	TYP	MAX	UNITS	TEST COND
PEAK WAVELENGTH			625		nm	
FORWARD VOLTAGE	$V_f$		2.1	3.2	V	$I_f=350\text{mA}$
REVERSE VOLTAGE	$V_r$	5			V	$I_r=10\mu\text{A}$
AXIAL INTENSITY(*1)	$I_v$		22		lm	$I_f=350\text{mA}$
VIEWING ANGLE			110		$2x \theta_{\text{theta}}$	
EMITTED COLOR:			RED			
EPOXY LENS FINISH:			WATER CLEAR			

LIMITS OF SAFE OPERATION AT 25°C

PARAMETER	SYMBOL	MAX	UNITS
PULSE FORWARD CURRENT	$I_p$	400	mA
STEADY CURRENT	$I_F$	350	mA
POWER DISSIPATION	$P_D$	1.1	W
OPERATING TEMP.	$T_{OPR}$	-20 TO +70	°C
STORAGE TEMP.	$T_{STG}$	-40 TO +85	°C

\*DUTY 1/10 PULSE WIDTH 10ms

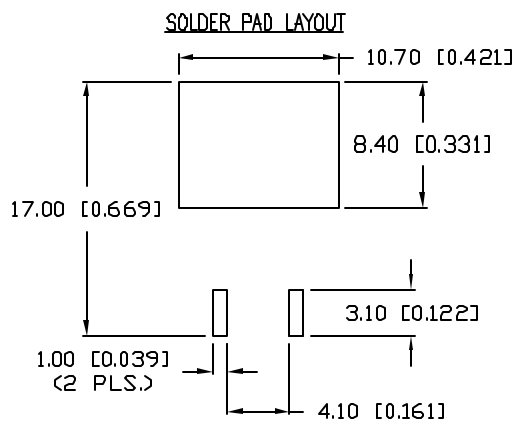
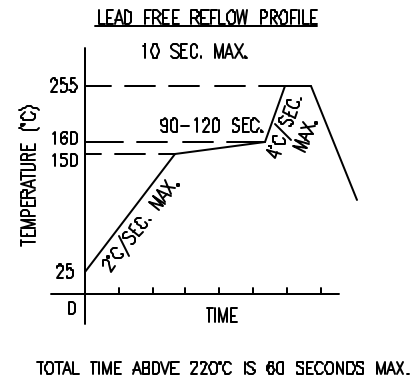

CAUTION: STATIC SENSITIVE DEVICE  
FOLLOW PROPER E.S.D. HANDLING PROCEDURES  
WHEN WORKING WITH THIS PART.

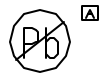

NOTES:  
1. 50 PCS. IN EACH TUBE.

UNCONTROLLED DOCUMENT

\*UNLESS OTHERWISE SPECIFIED TOLERANCES PER DECIMAL PRECISION ARE: X=±1 (±0.039), XX=±0.5 (±0.020), XXX=±0.25 (±0.010), XXXX=±0.127 (±0.005). LEAD SIZE=±0.05 (±0.002), LEAD LENGTH=±0.75 (±0.030), MIN=+0.00 DECIMAL PRECISION MAX.=+0.00 DECIMAL PRECISION

REV.	PART NUMBER
A	SML-LX1610SIC/A

CONFIDENTIAL INFORMATION  
THE INFORMATION CONTAINED IN THIS DOCUMENT IS THE PROPERTY OF LUMEX INC. EXCEPT AS SPECIFICALLY AUTHORIZED IN WRITING BY LUMEX INC, THE HOLDER OF THIS DOCUMENT SHALL KEEP ALL INFORMATION CONTAINED HEREIN CONFIDENTIAL AND SHALL PROTECT SAME IN WHOLE OR IN PART FROM DISCLOSURE AND DISSEMINATION TO ALL THIRD PARTIES.



290 E. HELEN ROAD  
PALATINE, IL 60067-6976  
PHONE: +1.847.359.2790  
US WEB: www.lumex.com  
TW WEB: www.lumex.com.tw

10.60 x 10mm HIGH POWER LED, 625nm RED LED.

RELIABILITY NOTE  
OUR MANY YEARS OF EXPERIENCE DATA ACCUMULATION INDICATE THAT SOLDER HEAT IS A MAJOR CAUSE OF EARLY AND FUTURE FAILURE. PLEASE PAY ATTENTION TO YOUR SOLDERING PROCESS.

DRAWN BY:	CHECKED BY:	APPROVED BY:	DATE:
JC			8.31.06
			PAGE: 1 OF 1
			SCALE: N/A