

MAX17116 Evaluation Kit

Evaluates: MAX17116 in a 12-Pin UTDFN Package

General Description

The MAX17116 evaluation kit (EV kit) is a fully assembled and tested surface-mount PCB that evaluates the MAX17116 dual-output DC/DC power supply for active-matrix organic light-emitting diode (AMOLED) displays, available in a 12-pin UTDFN package with an exposed pad. The EV kit includes dual switch-mode power-supply (SMPS) outputs, a fixed 4.6V PWM step-up regulator, and an adjustable (-5.4V to -1.5V) PWM inverting regulator. The EV kit operates from a +2.3V to +4.2V single power supply.

Features

- ◆ +2.3V to +4.2V Input Range
- ◆ High-Performance PWM Step-Up Regulator
- ◆ High-Performance PWM Inverting Regulator
- ◆ 1.4MHz Switching Frequency
- ◆ Shutdown Control
- ◆ Proven PCB Layout
- ◆ Fully Assembled and Tested

[Ordering Information](#) appears at end of data sheet.

Component List

DESIGNATION	QTY	DESCRIPTION
C1, C3	2	4.7 μ F \pm 10%, 10V X5R ceramic capacitors (0603) TDK C1608X5R1A475K
C2, C4	2	10 μ F \pm 10%, 10V X7R ceramic capacitors (0805) Murata GRM21BR71A106K
C5, C6	0	Not installed, ceramic capacitors (0805)
JU1	1	3-pin header
L1, L2	2	4.7 μ H, 0.9A low-profile inductors Sumida CDH36D07HF-4R7MC

DESIGNATION	QTY	DESCRIPTION
R1	0	Not installed, resistor—short PC trace (0603)
U1	1	Dual-output DC/DC power supply for AMOLED displays (12 UTDFN-EP) Maxim MAX17116EVC+
—	1	Shunt
—	1	PCB: MAX17116 EVALUATION KIT

Component Suppliers

SUPPLIER	PHONE	WEBSITE
Murata Electronics North America, Inc.	770-436-1300	www.murata-northamerica.com
Sumida Corp.	847-545-6700	www.sumida.com
TDK Corp.	847-803-6100	www.component.tdk.com

Note: Indicate that you are using the MAX17116 when contacting these component suppliers.

MAX17116 Evaluation Kit

Evaluates: MAX17116 in a 12-Pin UTDFN Package

Quick Start

Recommended Equipment

- MAX17116 EV kit
- +2.3V to +4.2V, 1A power supply (VIN)
- Two digital voltmeters

Procedure

The EV kit is fully assembled and tested. Follow the steps below to verify board operation. **Caution: Do not turn on the power supply until all connections are completed.**

- 1) Verify that jumper JU1 is in the default position, as shown in Table 1.
- 2) Connect the positive terminal of the power supply to the VIN PCB pad and the negative terminal to the nearest PGND PCB pad.
- 3) Connect the first voltmeter across the ELVDD PCB pad and the nearest PGND PCB pad.
- 4) Connect the second voltmeter across the ELVSS PCB pad and the nearest PGND PCB pad.
- 5) Turn on the DC power supply.
- 6) Verify that the voltmeters display $V_{ELVDD} = +4.6V$ and $V_{ELVSS} = -4.9V$.

Detailed Description of Hardware

The MAX17116 EV kit includes two current-mode 1.4MHz SMPS regulators for AMOLED displays. The positive supply is provided by a step-up regulator with a synchronous rectifier. The negative supply is provided

by an inverting regulator with a synchronous rectifier. The step-up regulator output is a fixed voltage of +4.6V and the inverting regulator output is adjustable from -5.4V to -1.5V through the single-wire EN serial interface. The EV kit operates from a +2.3V to +4.2V single power supply.

Step-Up Regulator

The EV kit includes a step-up DC-DC converter with an integrated power MOSFET switch and synchronous rectifier. The step-up regulator output (ELVDD) has a fixed voltage of +4.6V and can provide an output current of 250mA.

Inverting Converter

The EV kit contains an inverting DC-DC converter with integrated power MOSFET switch and synchronous rectifier. The inverting regulator output (ELVSS) is adjustable from -5.4V to -1.5V and can provide an output current of 250mA. The ELVSS output voltage can be adjusted through the single-wire EN serial interface.

Enable Input and Serial Interface Input

The EV kit features a 3-pin jumper (JU1) to control the enable input and an EN test pad to access the serial interface input. Connect EN to IN for normal operation. Connect EN to AGND to place the device into shutdown mode.

The enable pin is also used as a serial-interface input to adjust the inverting converter output voltage. With no shunts installed on jumper JU1, connect an external pulse generator at the EN test pad and send the required serial pulses. Refer to the *EN Serial Interface* section in the MAX17116 IC data sheet for a more detailed description. Table 1 lists the selectable jumper options.

Table 1. Jumper JU1 Function

SHUNT POSITION	EN PIN	SMPS REGULATORS
1-2*	Connected to IN	$V_{ELVDD} = +4.6V$ $V_{ELVSS} = -4.9V$
2-3	Connected to AGND	$V_{ELVDD} = 0V$ $V_{ELVSS} = 0V$
Not installed	External pulses must be applied to the EN test pad	$V_{ELVDD} = +4.6V$ $V_{ELVSS} = -5.4V$ to $-1.5V$ (based on EN pulses)

*Default position.

MAX17116 Evaluation Kit

Evaluates: MAX17116 in a 12-Pin UTDFN Package

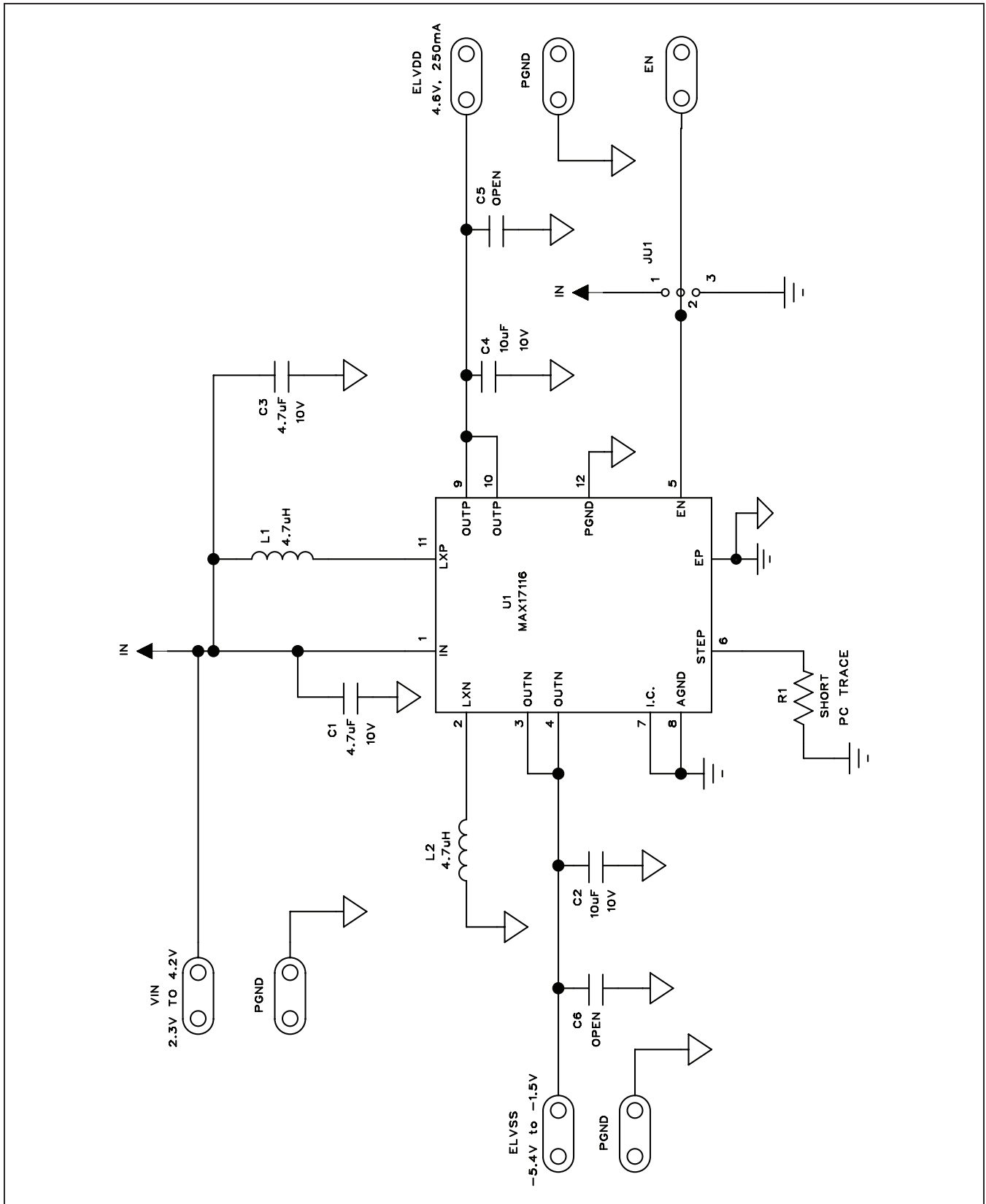

Figure 1. MAX17116 EV Kit Schematic

MAX17116 Evaluation Kit

Evaluates: MAX17116 in a 12-Pin UTDFN Package

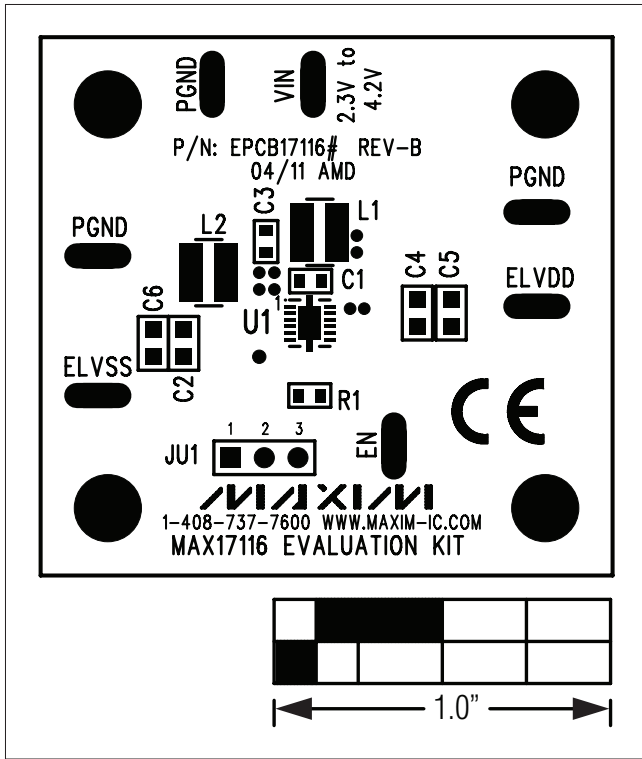

Figure 2. MAX17116 EV Kit Component Placement Guide—Component Side

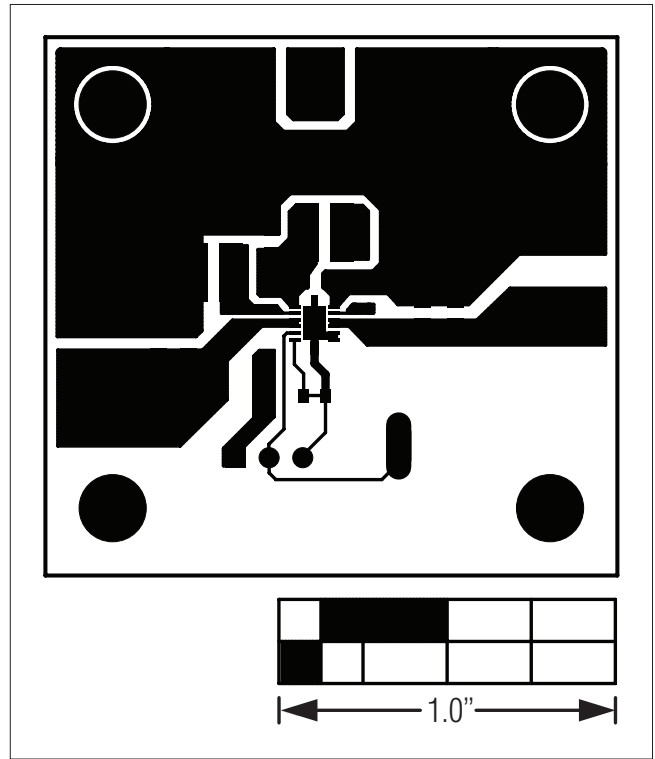

Figure 3. MAX17116 EV Kit PCB Layout—Component Side

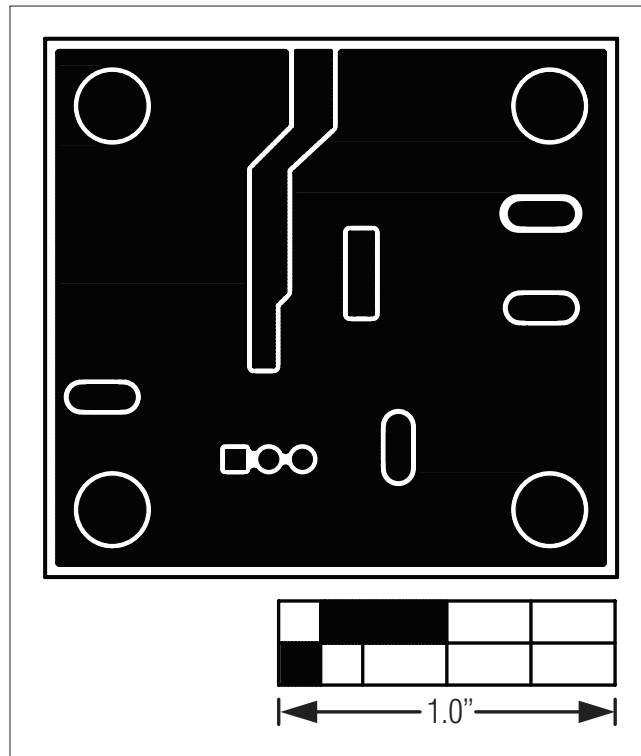

Figure 4. MAX17116 EV Kit PCB Layout—Solder Side

MAX17116 Evaluation Kit

Evaluates: MAX17116 in a 12-Pin UTDFN Package

Ordering Information

PART	TYPE
MAX17116EVKIT#	EV Kit

#Denotes RoHS compliant.

MAX17116 Evaluation Kit

Evaluates: MAX17116 in a 12-Pin UTDFN Package

Revision History

REVISION NUMBER	REVISION DATE	DESCRIPTION	PAGES CHANGED
0	5/11	Initial release	—

Maxim cannot assume responsibility for use of any circuitry other than circuitry entirely embodied in a Maxim product. No circuit patent licenses are implied. Maxim reserves the right to change the circuitry and specifications without notice at any time.

Maxim Integrated Products, 120 San Gabriel Drive, Sunnyvale, CA 94086 408-737-7600 _____ 6