

MAX16840 Evaluation Kit

Evaluates: MAX16840

General Description

The MAX16840 evaluation kit (EV kit) demonstrates the MAX16840 HBLED driver IC used for solid-state lighting (SSL) applications. The EV kit is configured in a buck-boost topology providing an output power of 5.5W for 3 to 5 LEDs. The IC is designed for standard multifaceted-reflector (MR) applications. The EV kit's typical input power is 6.7W at 12V AC and features a power-factor correction of 0.9 (typ).

The EV kit is a fully assembled and tested surface-mount PCB designed and optimized to accommodate an MR16 application form factor. The EV kit is dimmable with some electronic transformers and trailing-edge dimmer combination and some magnetic transformers and leading-edge dimmer combination.

Features

- ◆ **Input Voltage Ranges**
 - 9V AC to 13.2V AC from AC Source or Magnetic Transformers
 - 9V DC to 18V DC
 - Output of Several Electronic Transformers
- ◆ **Drives 3 to 5 Series HBLEDs**
- ◆ **36V Overvoltage Protection**
- ◆ **5.5W Output Power**
- ◆ **Demonstrates IC Power-Factor Correction**
- ◆ **Proven PCB Layout**
- ◆ **Fully Assembled and Tested**

[Ordering Information](#) appears at end of data sheet.

Component List

DESIGNATION	QTY	DESCRIPTION
AC1, AC2, LED+, LED-, LED-B	0	Not installed, test points
C1, C8	2	0.33 μ F \pm 10%, 25V X7R ceramic capacitors (0805) Murata GRM21BR71E334K
C2, C9	2	10 μ F \pm 10%, 25V X7R ceramic capacitors (1206) Taiyo Yuden TMK316AB7106K
C3	1	2.2 μ F \pm 10% 6.3V X7R ceramic capacitor (0603) AVX 06036C225KAT2A
C4	1	0.1 μ F \pm 10%, 50V X7R ceramic capacitor (0603) Murata GRM188R71H104K
C5	1	1500pF \pm 10%, 50V X7R ceramic capacitor (0603) Murata GRM188R71H152KA
C6	1	220pF \pm 5%, 50V C0G ceramic capacitor (0603) Murata GRM1555C1H221J
C7	1	2.2 μ F \pm 10%, 16V X7R ceramic capacitor (1206) Murata GRM31MR71C225K

DESIGNATION	QTY	DESCRIPTION
C10	0	Not installed, ceramic capacitor (1206)
C11	1	1000pF \pm 5%, 50V C0G ceramic capacitor (0402) Murata GRM1555C1H102J
D1	1	3A, 60V Schottky diode (SMA) Diodes Inc. B360A-13-F
D2	1	Schottky bridge rectifier diode (HD DIP) Central Semi CBRHDSH1-40L
D3	1	36V zener diode (SOD323) Fairchild MM3Z36VC (Top Mark: ZV)
D4	1	4.3V zener diode (SOD123) Fairchild MMSZ5229B (Top Mark: D4)
F1	1	1.75A, 63V fuse
L1	1	27 μ H, 3.1A inductor Würth 7447798271
L2	1	3.3 μ H, 1A inductor TDK MLP2520S3R3S

MAX16840 Evaluation Kit

Evaluates: MAX16840

Component List (continued)

DESIGNATION	QTY	DESCRIPTION
L3	1	22 μ H, 1.75A inductor TDK VLC6045T-220M
Q1	1	60V, 20mA npn transistor (SOT23) Central Semi CMPT3904E (Top Mark: C1AE)
Q2	1	30V, 50mA, dual npn transistor (SOT363) Central Semi CMKT5088 (Top Mark: K88)
R1	1	100 Ω \pm 5% resistor (0603)
R2	1	1k Ω \pm 5% resistor (0603)
R3	1	0.22 Ω \pm 1%, 1/3W resistor (1206) TT Electronics /IRC LRC -LR1206LF-01-R220-F
R4	1	34.8k Ω \pm 1% resistor (0603)

DESIGNATION	QTY	DESCRIPTION
R5	1	10k Ω \pm 5% resistor (0603)
R6	1	22V, 400A varistor (1210)
R7	1	10k Ω \pm 1% resistor (0603)
R8	1	340k Ω \pm 1% resistor (0603)
R9, R10	2	12k Ω \pm 5% resistors (0402)
R11	1	1.5k Ω , 1/4W resistor (0805) Panasonic-ECG ERJ-P06J152V
R12	1	0.25 Ω \pm 1%, 1/2W resistor (1206) TT Electronics/IRC LRC-LR1206LF-01-R250
U1	1	LED driver with integrated switch (10 TDFN-EP) Maxim MAX16840ATB+ (Top Mark: AWY)
—	1	PCB: MAX16840 EVALUATION KIT

Component Suppliers

SUPPLIER	PHONE	WEBSITE
AVX Corporation	843-946-0238	www.avx.com
Central Semiconductor Corp.	631-435-1110	www.centrasemi.com
Coilcraft, Inc.	847-639-6400	www.coilcraft.com
Diodes Incorporated	805-446-4800	www.diodes.com
Littelfuse, Inc.	773-628-1000	www.littelfuse.com
Murata Electronics North America, Inc.	770-436-1300	www.murata-northamerica.com
Panasonic Corp.	800-344-2112	www.panasonic.com
Taiyo Yuden	800-348-2496	www.t-yuden.com
TDK Corp.	847-803-6100	www.component.tdk.com
TT Electronics, PLC (IRC, Inc.)	40-0-1932-841310	www.ttelectronics.com

Note: Indicate you are using the MAX16840 when contacting these component suppliers.

Quick Start

Required Equipment

- MAX16840 EV kit
- AC or DC source
- 3 to 5 series-connected LED strings rated no less than 500mA
- Current probe to measure the LED current

Procedure

The EV kit is fully assembled and tested. Follow the steps below to verify board operation. **Caution: Do not turn on the power supply until all connections are completed.**

- 1) Connect the AC or DC source to the AC1 and AC2 test-point holes.
- 2) Connect the LED string anode and cathode to the LED+ and LED- test-point holes, respectively.
- 3) Clip the current probe across the LED+ wire to measure the LED current.
- 4) Enable the power supply.
- 5) Measure the LED current using the current probe.

MAX16840 Evaluation Kit

Evaluates: MAX16840

Detailed Description of Hardware

The MAX16840 EV kit demonstrates the MAX16840 HBLED driver IC. The IC is an average current-mode-control HBLED driver IC for step-down (buck), step-up (boost), and step-down/step-up (buck-boost) topologies in low-voltage SSL applications. The IC has an integrated 0.2Ω (max), 48V switching MOSFET that allows the device to be used in lighting applications for MR16 and other SSL applications for power levels up to 10W. The IC uses a proprietary input current-control scheme to achieve power-factor correction. The IC's LED driver uses constant-frequency average current-mode control to control the duty cycle of the integrated switching MOSFET. The IC is available in a 10-pin TDFN package with an exposed pad.

The EV kit circuit is configured in a buck-boost topology, which operates at the IC's fixed 300kHz switching frequency and provides up to 5.5W of output power for a string of 3 to 5 series HBLEDs connected at the LED+ and LED- test-point holes. The EV kit circuit operates from a 9V to 13.2V AC or DC supply voltage and from electronic transformers. The EV kit is designed on a proven 2oz copper, two-layer, small PCB-footprint design that accommodates an MR16 application form factor.

The IC uses average current-mode control and the circuit is configured such that the average current flows in current-sense resistor R3 on a cycle-by-cycle (switching frequency) basis and is set by the voltage on the REF1 pin. The average current per switching cycle flowing into R3 is:

$$I_{AV} = \frac{V_{REF1}}{6.075 \times R3}$$

where V_{REF1} is the voltage at the IC's REF1 pin and R3 is in ohms.

Circuit components C3, C7, Q2, R4, and R7–R10 are used to average the rectified AC voltage and control the input current. Components R7 and C7 form a lowpass filter, with the average input voltage present across C7.

The averaged voltage is then used to control the current in the current-mirror circuit formed by R8, R9, R10, and Q2. The current flowing into R8 is approximately proportional to the voltage on C7 and is reflected on pin 3 of Q2 and sinks the same amount of current from pin 3 of Q2, which flows into R8. The IC has a 50 μ A current source available at the REF1 pin. The current flowing into R4 sets the input current or the average current flowing into R3. The circuit attempts to maintain the input power over the input voltage range of 9V AC to 13.2V AC almost constant, thus achieving LED current regulation in the range of $\pm 10\%$ over the input range.

Inductor L2 is 3.3 μ H and has no effect for DC input voltages and low-frequency AC input voltages when the MR16 is powered from a magnetic transformer. Figure 1 illustrates the input-current waveforms when the EV kit is powered from a magnetic transformer with a 12V AC 60Hz output.

Inductor L2 has an effect when the unit is powered from an electronic transformer (Figure 2).

Notice that the peak current drawn has increased with the addition of the inductor (Figure 3). The first peak drawn every 120Hz is ignored and consists of the input current drawn by the IC circuit and the input capacitors.

Maximum LED+ Voltage

The IC features an internal 46V overvoltage protection at the IN pin to protect the internal switching MOSFET from damage if the LED string is open or if the voltage on the LED string is too high. However, when operating the EV kit buck-boost circuit, the LED+ voltage should be limited to 40V.

Electronic and Magnetic Transformer Compatibility

The MR16 board was tested with 4 LEDs for electronic and magnetic transformer compatibility and also with the appropriate dimmers. See Table 1 for the results with the different transformer models tested.

MAX16840 Evaluation Kit

Evaluates: MAX16840

Table 1. Electronic Transformers Tested

MANUFACTURER (MODEL NAME)	RATED INPUT VOLTAGE AND POWER	MEASURED (pF)	PERFORMANCE (V)*	LED OUTPUT VOLTAGE (V)	LED OUTPUT CURRENT (mA)
LIGHTECH**					
Ligtech LVT60	120V, 60W	0.963	108 to 132	25.1	108 to 213
					120 to 221
					132 to 225
Ligtech LET60	120V, 60W	0.96	108 to 132	25.8	108 to 215
					120 to 223
					132 to 225
Ligtech LET75	120V, 75W	0.95	108 to 132	25.6	108 to 217
					120 to 224
					132 to 226
Ligtech LET105	120V, 105W	0.95	108 to 132	25.2	108 to 217
					120 to 220
					132 to 223
Ligtech LET151	120V, 150W	0.95	108 to 132	25	108 to 170
					120 to 203
					132 to 213
PONY**					
Pony PET-120-12-75	120V, 75W	0.95	108 to 132	25.2	108 to 214
					120 to 223
					132 to 225
Pony PET-120-12-60	120V, 60W	0.95	108 to 132	25.3	108 to 215
					120 to 220
					132 to 224
BL TECHNOLOGY**					
BL Technology CV-10/75-12	120V, 75W	0.95	108 to 132	25.4	108 to 219
					120 to 224
					132 to 225
BL Technology CV-10/60-12	120V, 60W	0.95	108 to 132	25.4	108 to 221
					120 to 225
					132 to 222
BL Technology CV-10/150-12	120V, 150W	0.9	108 to 132	25.1	108 to 214
					120 to 228
					132 to 235
VARILIGHT**					
Varilight YT70L	230V, 0 to 70W	0.896	207 to 254	25.4	207 to 218
					230 to 226
					254 to 224
Varilight YT150	230V, 0 to 150W	0.73	207 to 254	25.3	207 to 220
					230 to 222
					254 to 222

MAX16840 Evaluation Kit

Evaluates: MAX16840

Table 1. Electronic Transformers Tested (continued)

MANUFACTURER (MODEL NAME)	RATED INPUT VOLTAGE AND POWER	MEASURED (pF)	PERFORMANCE (V)**	LED OUTPUT VOLTAGE (V)	LED OUTPUT CURRENT (mA)
OSRAM					
Osram HALOTRONIC HTN 75/230-240	230V to 240V, 20W to 75W	0.88	207 to 254	25.4	207 to 208
					230 to 217
					254 to 224
Osram HALOTRONIC HTN 70/230-240	230V to 240V, 20W to 70W	0.942	207 to 254	25.3	207 to 200
					230 to 213
					254 to 222
Osram HALOTRONIC HTN 105/230-240	230V to 240V, 35W to 105W	0.91	207 to 254	25.1	207 to 203
					230 to 215
					254 to 224
Osram ET-PARROT 105	220V to 240V, 35W to 105W	0.89	207 to 254	25.2	207 to 199
					230 to 213
					254 to 221
Osram ET-P 60	220V to 240V, 20W to 60W	0.84	207 to 254	25.3	207 to 201
					230 to 214
					254 to 222
NOBILE					
Nobile EN-60D	230V, 20W to 60W	0.866	207 to 254	25.4	207 to 216
					230 to 223
					254 to 223
NVC					
NVC ET-60E	220V, 20W to 50W	0.942	198 to 242	25.2	198 to 211
					220 to 219
					242 to 223
TCL					
TCL ET-60H	220V, 20W to 60W	0.932	213 to 242	25.4	213 to 217
					220 to 220
					242 to 225
CDN					
CDN CS60	220V	0.932	198 to 242	25.3	198 to 213
					220 to 220
					242 to 226

*No flicker from the designated voltage range.

**No flickering with Lutron SELVB-300PH-WH (ELV-300W) trailing-edge dimmers.

MAX16840 Evaluation Kit

Evaluates: MAX16840

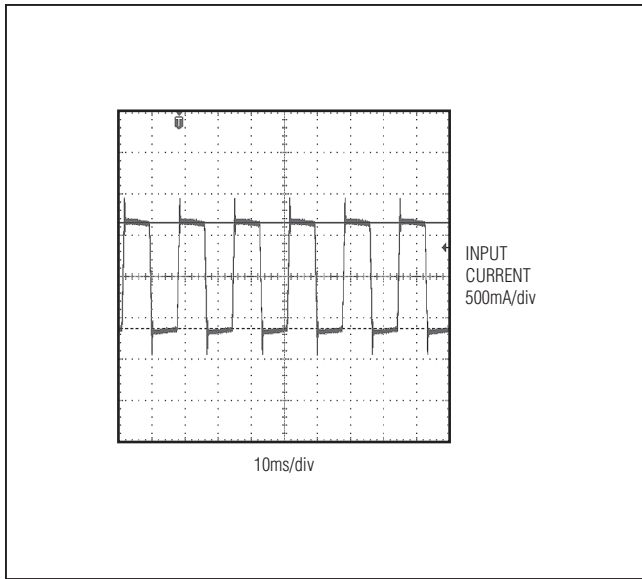

Figure 1. Input Current Waveform Using a Magnetic Transformer

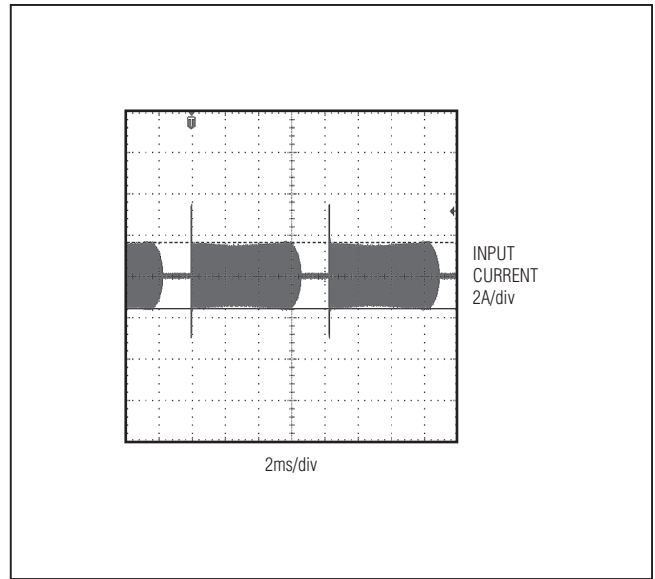

Figure 2. Input Current Waveform Using an Electronic Transformer with L2 Shorted

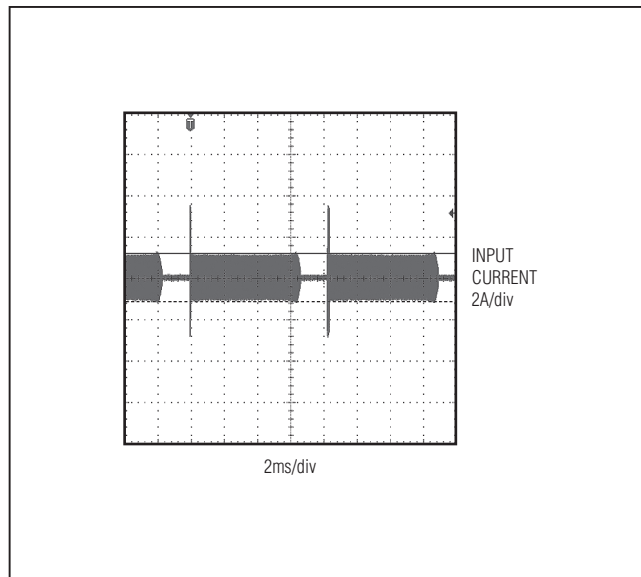

Figure 3. Input Current Waveform Using an Electronic Transformer with L2 Installed

MAX16840 Evaluation Kit

Evaluates: MAX16840

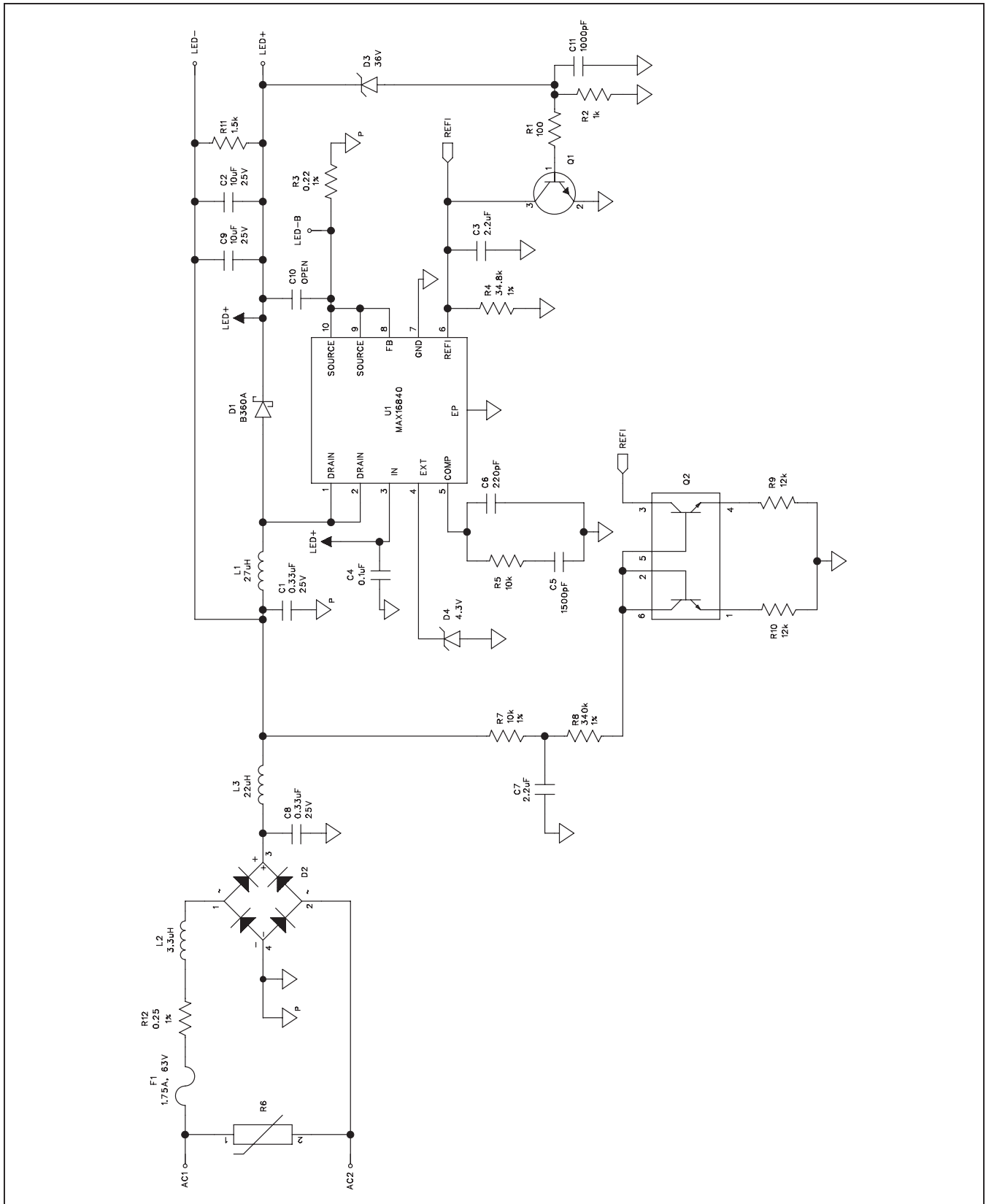

Figure 4. MAX16840 EV Kit Schematic

MAX16840 Evaluation Kit

Evaluates: MAX16840

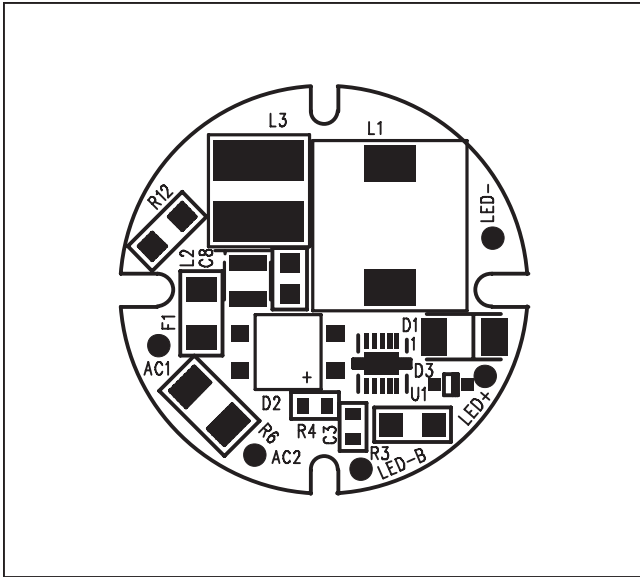

Figure 5. MAX16840 EV Kit Component Placement Guide—Component Side

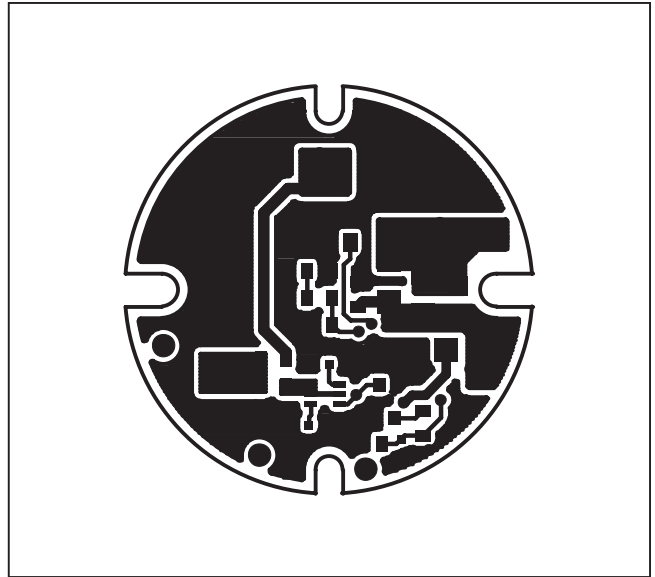

Figure 7. MAX16840 EV Kit PCB Layout—Solder Side

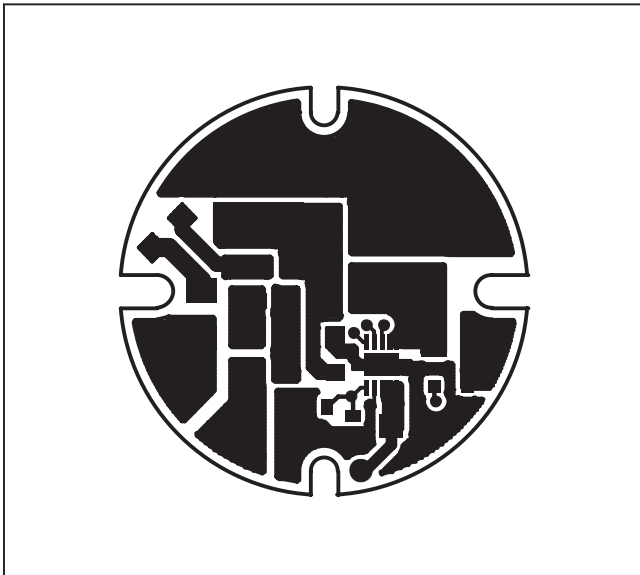

Figure 6. MAX16840 EV Kit PCB Layout—Component Side

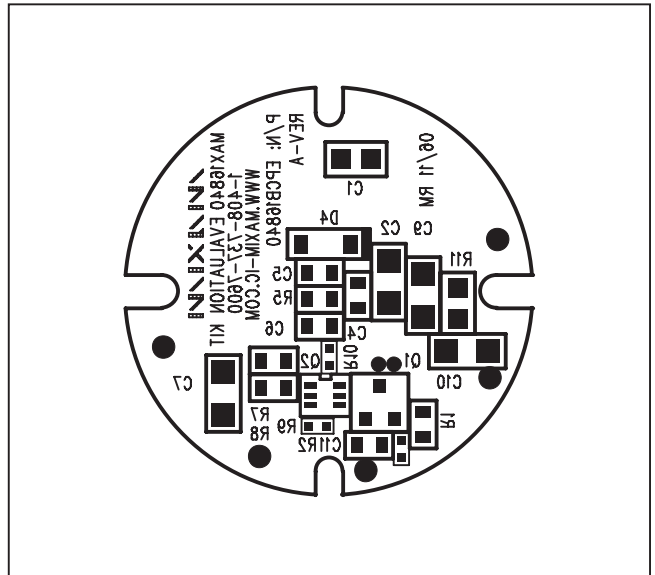

Figure 8. MAX16840 EV Kit Component Placement Guide—Solder Side

MAX16840 Evaluation Kit

Evaluates: MAX16840

Ordering Information

PART	TYPE
MAX16840EVKIT#	EV Kit

#Denotes RoHS compliant.

MAX16840 Evaluation Kit

Evaluates: MAX16840

Revision History

REVISION NUMBER	REVISION DATE	DESCRIPTION	PAGES CHANGED
0	6/11	Initial release	—

Maxim cannot assume responsibility for use of any circuitry other than circuitry entirely embodied in a Maxim product. No circuit patent licenses are implied. Maxim reserves the right to change the circuitry and specifications without notice at any time.

Maxim Integrated Products, 120 San Gabriel Drive, Sunnyvale, CA 94086 408-737-7600 _____ 10