



MIC23603

4MHz PWM 6A Buck Regulator with HyperLight Load[®]

Revision 1.1

General Description

The MIC23603 is a high-efficiency 4MHz 6A synchronous buck regulator with HyperLight Load[®] mode. HyperLight Load provides very high efficiency at light loads and ultra-fast transient response which is perfectly suited for supplying processor core voltages. An additional benefit of this proprietary architecture is very low output ripple voltage throughout the entire load range with the use of small output capacitors. The tiny 4mm x 5mm DFN package saves precious board space and requires few external components.

The MIC23603 is designed for use with a very small inductor, down to 0.33 μ H, and an output capacitor as small as 47 μ F that enables a sub-1mm height.

The MIC23603 has a very low quiescent current of 24 μ A and achieves as high as 81% efficiency at 1mA. At higher loads, the MIC23603 provides a constant switching frequency around 4MHz while achieving peak efficiencies up to 93%.

The MIC23603 is available in 20-pin 4mm x 5mm DFN package with an operating junction temperature range from -40°C to +125°C.

Datasheets and support documentation are available on Micrel's web site at: www.micrel.com.

Features

- Input voltage: 2.7V to 5.5V
- 6A output current
- Up to 93% efficiency and 81% at 1mA
- 24 μ A typical quiescent current
- 4MHz PWM operation in continuous mode
- Ultra-fast transient response
- Power Good
- Programmable soft-start
- Low voltage output ripple
 - 14mVpp ripple in HyperLight Load mode
 - 5mV output voltage ripple in full PWM mode
- Fully integrated MOSFET switches
- 0.01 μ A shutdown current
- Thermal shutdown and current limit protection
- Output voltage as low as 0.65V
- 20-pin 4mm x 5mm DFN
- -40°C to +125°C junction temperature range

Applications

- 5V POL supplies
- μ C/ μ P, FPGA and DSP power
- Test and measurement systems
- Barcode readers
- Set-top box, Modems, and DTV
- Distributed power systems
- Networking systems

Typical Application

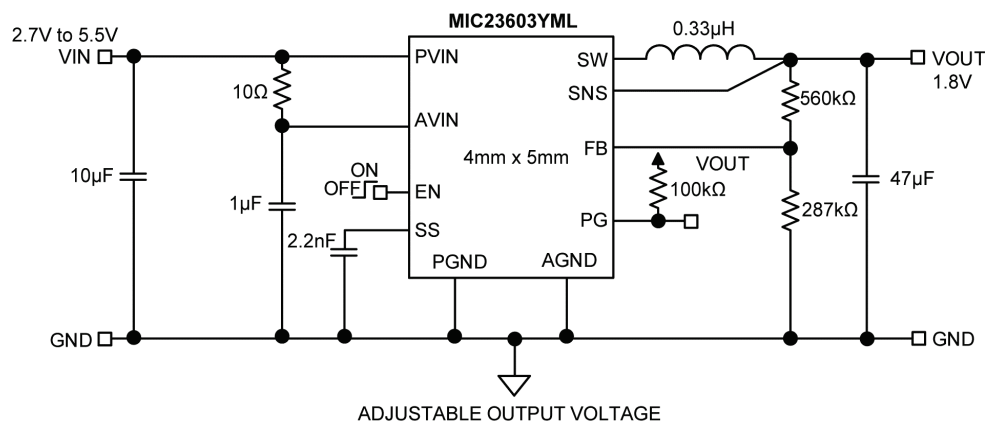

HyperLight Load is a registered trademark of Micrel, Inc.

Micrel Inc. • 2180 Fortune Drive • San Jose, CA 95131 • USA • tel +1 (408) 944-0800 • fax + 1 (408) 474-1000 • <http://www.micrel.com>

November 5, 2013

Revision 1.1

Ordering Information

Part Number	Nominal Output Voltage	Junction Temp. Range	Package ⁽¹⁾	Lead Finish
MIC23603YML	ADJ	-40°C to +125°C	20-pin 4mm x 5mm DFN	Pb-Free

Notes:

- DFN is GREEN RoHS-compliant package. Lead finish is NiPdAu. Mold compound is Halogen Free.

Pin Configuration

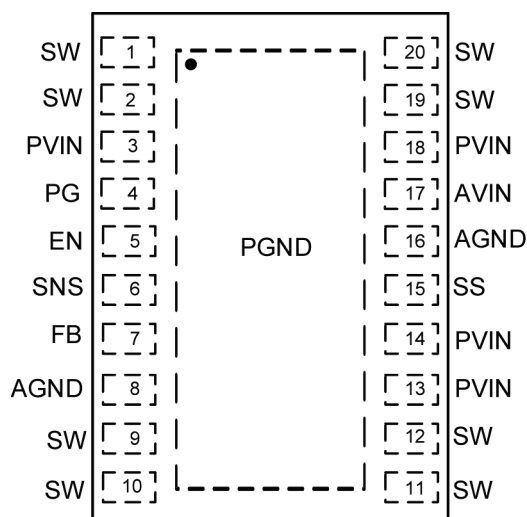

20-Pin 4mm x 5mm DFN (ML)
(Top View)

Pin Description

Pin Number	Pin Name	Pin Function
1, 2, 9-12, 19, 20	SW	Switch output. Internal power MOSFET output switches.
3, 13, 14, 18	PVIN	Input voltage. Connect a capacitor to ground to decouple the noise.
4	PG	Power good. Connect an external resistor to a voltage source to supply a power good indicator.
5	EN	Enable input. Logic high enables operation of the regulator. Logic low shuts down the device. Do not leave floating.
6	SNS	Sense input. Connect to VOUT as close to output capacitor as possible to sense output voltage.
7	FB	Feedback input. Connect an external divider between VOUT and ground to program the output voltage.
8, 16	AGND	Analog ground. Connect to central ground point where all high current paths meet (CIN, COUT, PGND) for best operation.
15	SS	Soft Start. Place a capacitor from this pin to ground to program the soft start time. Do not leave floating, 2.2nF minimum C _{SS} is required.
17	AVIN	Supply voltage. Analog control circuitry. Connect to VIN through a 10Ω resistor.
EP	PGND	Power Ground.

Absolute Maximum Ratings⁽¹⁾

Supply Voltage (V_{IN})	6V
Sense (V_{SNS})	6V
Output Switch Voltage	6V
Enable Input Voltage (V_{EN})	-0.3V to V_{IN}
Storage Temperature Range	-65°C to +150°C
ESD Rating ⁽³⁾	ESD SENSITIVE

Operating Ratings⁽²⁾

Supply Voltage (V_{IN})	2.7V to 5.5V
Enable Input Voltage (V_{EN})	0V to V_{IN}
Output Voltage Range (V_{SNS})	0.65V to 3.6V
Junction Temperature Range (T_J)	-40°C ≤ T_J ≤ +125°C
Thermal Resistance	
4mm x 5mm DFN-20 (θ_{JA})	44.1°C/W

Electrical Characteristics⁽⁴⁾

$T_A = 25^\circ\text{C}$; $V_{IN} = V_{EN} = 3.6\text{V}$; $V_{OUT} = 1.8\text{V}$; $L = 0.33\mu\text{H}$; $C_{OUT} = 47\mu\text{F} \times 2$ unless otherwise specified.

Bold values indicate -40°C ≤ T_J ≤ +125°C, unless noted.

Parameter	Condition	Min	Typ	Max	Units
Supply Voltage Range		2.7		5.5	V
Undervoltage Lockout Threshold	Turn-on	2.2	2.5	2.8	V
Undervoltage Lockout Hysteresis			270		mV
Quiescent Current	$I_{OUT} = 0\text{mA}$, $SNS > 1.2 \times V_{OUT}$ Nominal		24	45	μA
Shutdown Current	$V_{EN} = 0\text{V}$, $V_{IN} = 5.5\text{V}$		0.01	5	μA
Feedback Voltage		0.605	0.62	0.636	V
Current Limit	$SNS = 0.9 \times V_{OUTNOM}$	6.5	12	16	A
Output Voltage Line Regulation	$V_{IN} = 3.6\text{V to } 5.5\text{V}$ if $V_{OUTNOM} < 2.5\text{V}$, $I_{LOAD} = 20\text{mA}$		0.3		%V
	$V_{IN} = 4.5\text{V to } 5.5\text{V}$ if $V_{OUTNOM} \geq 2.5\text{V}$, $I_{LOAD} = 20\text{mA}$				
Output Voltage Load Regulation	$20\text{mA} < I_{LOAD} < 500\text{mA}$, $V_{IN} = 3.6\text{V}$ if $V_{OUTNOM} < 2.5\text{V}$		0.3		%
	$20\text{mA} < I_{LOAD} < 500\text{mA}$, $V_{IN} = 5.0\text{V}$ if $V_{OUTNOM} \geq 2.5\text{V}$				
	$20\text{mA} < I_{LOAD} < 1\text{A}$, $V_{IN} = 3.6\text{V}$ if $V_{OUTNOM} < 2.5\text{V}$		0.7		%
	$20\text{mA} < I_{LOAD} < 1\text{A}$, $V_{IN} = 5.0\text{V}$ if $V_{OUTNOM} \geq 2.5\text{V}$				
PWM Switch ON-Resistance	$I_{SW} = 1000\text{mA}$ PMOS		0.03		Ω
	$I_{SW} = -1000\text{mA}$ NMOS		0.025		
Maximum Frequency	$I_{OUT} = 300\text{mA}$		4		MHz
Soft Start Time	$V_{OUT} = 90\%$, $C_{SS} = 2.2\text{nF}$		1200		μs
Power Good Threshold	% of $V_{NOMINAL}$	85	90	95	%
Power Good Hysteresis			20		%
Power Good Pull Down	$V_{SNS} = 90\% V_{NOMINAL}$, $I_{PG} = 1\text{mA}$			200	mV
Enable Threshold	Turn-On	0.4	0.8	1.2	V
Enable Input Current			0.1	2	μA
Overtemperature Shutdown			160		$^\circ\text{C}$
Overtemperature Shutdown Hysteresis			20		$^\circ\text{C}$

Notes:

- Exceeding the absolute maximum rating can damage the device.
- The device is not guaranteed to function outside its operating rating.
- Devices are ESD sensitive. Handling precautions are recommended. Human body model, 1.5k Ω in series with 100pF.
- Specification for packaged product only.

Typical Characteristics

Efficiency vs. Output Current

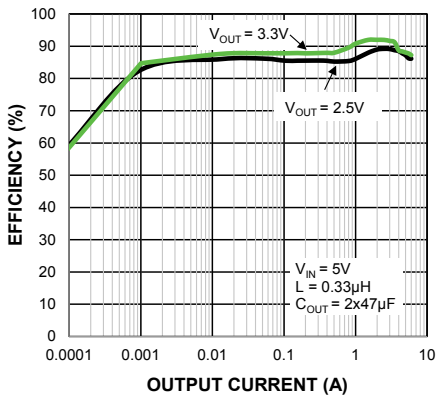

Efficiency vs. Output Current $V_{OUT} = 1.8V$

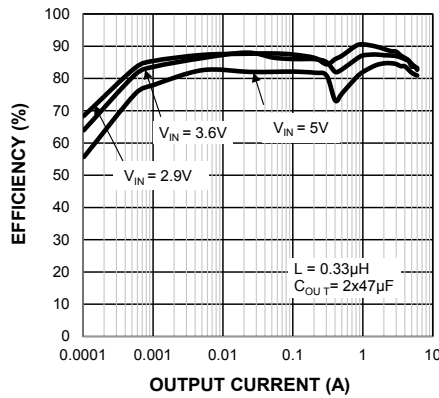

Efficiency vs. Output Current $V_{OUT} = 1.2V$

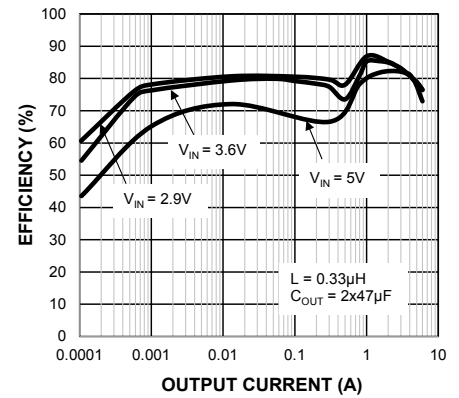

Output Voltage vs. Input Voltage

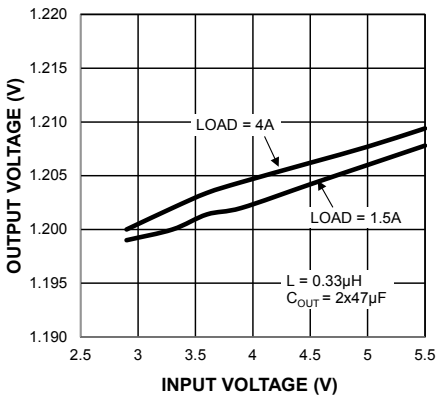

Output Voltage vs. Input Voltage

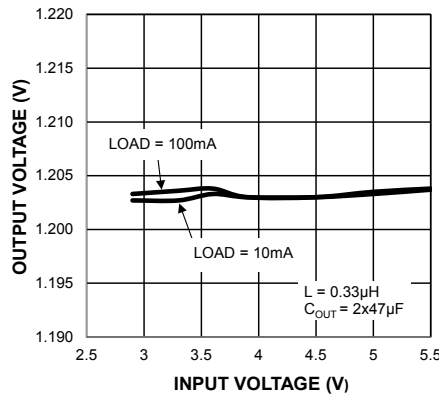

Output Voltage vs. Output Current (HLL)

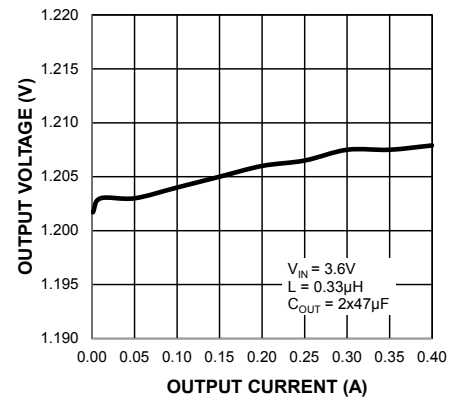

Output Voltage vs. Output Current (CCM)

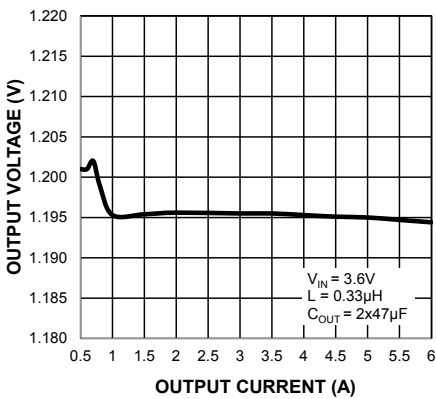

Enable Thresholds vs. Input Voltage

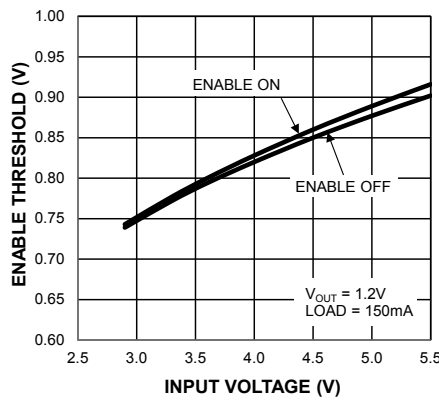

Enable Thresholds vs. Temperature

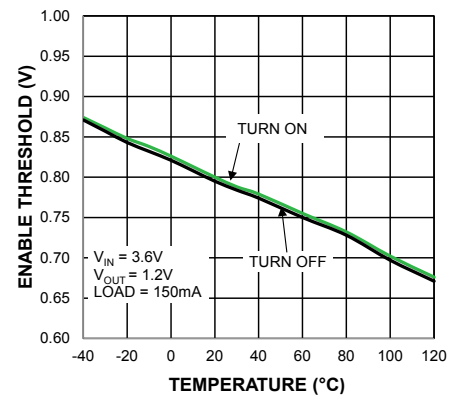

Typical Characteristics (Continued)

Undervoltage Lockout vs. Temperature

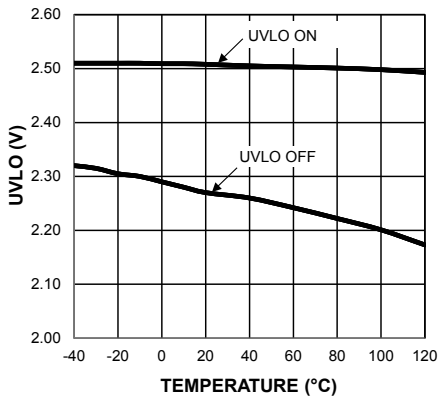

PGOOD Delay Time vs. Input Voltage

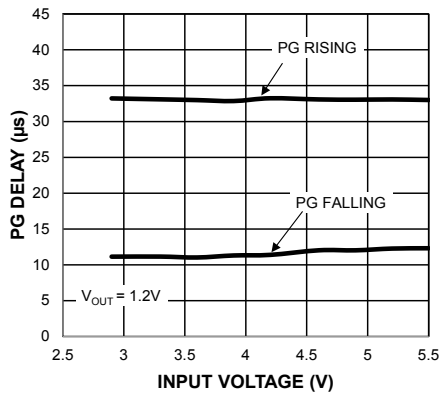

PGOOD Thresholds vs. Input Voltage

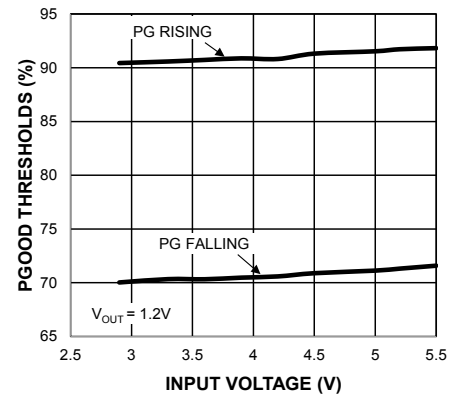

V_{OUT} Rise Time vs. C_{SS}

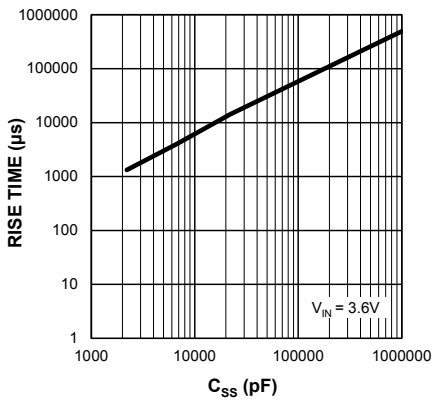

Output Voltage vs. Temperature

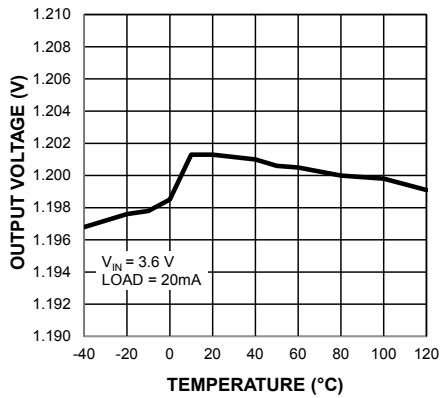

Feedback Voltage vs. Temperature

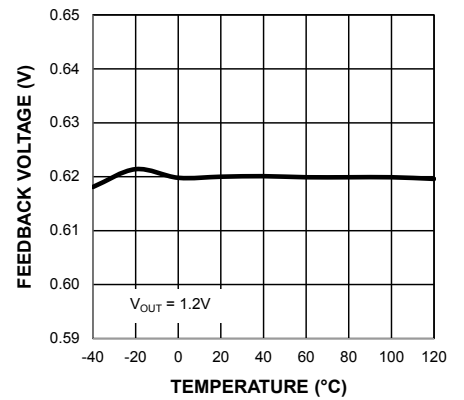

Quiescent Current vs. Input Voltage

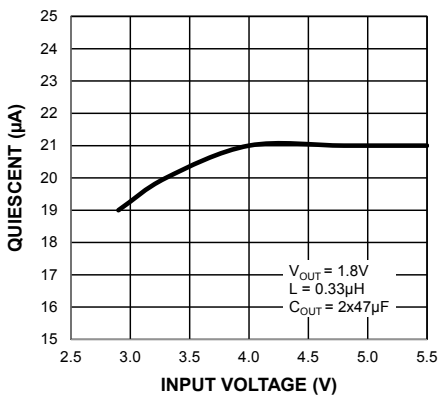

Switching Frequency vs. Load Current

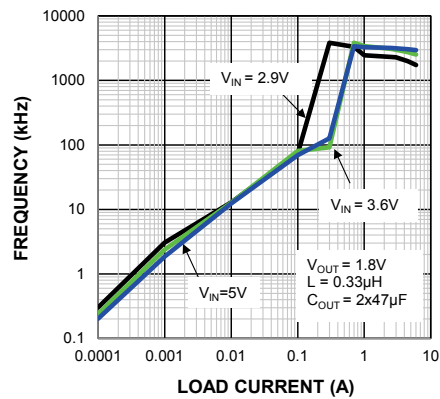

Current Limit vs. Input Voltage

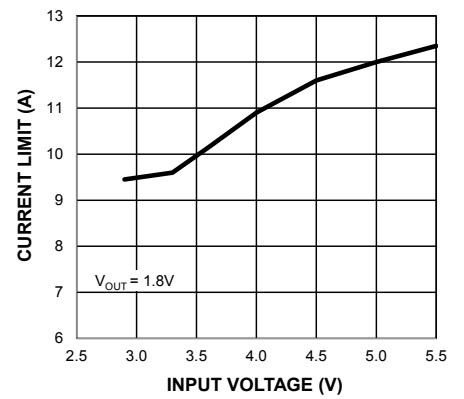

Typical Characteristics (Continued)

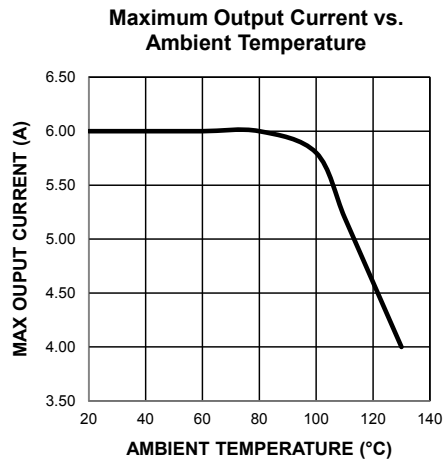

Functional Characteristics

Turn-On Input Current

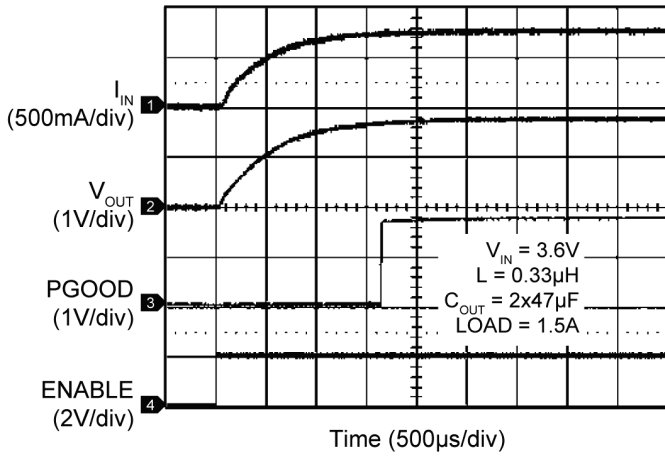

Start-Up Inductor Current

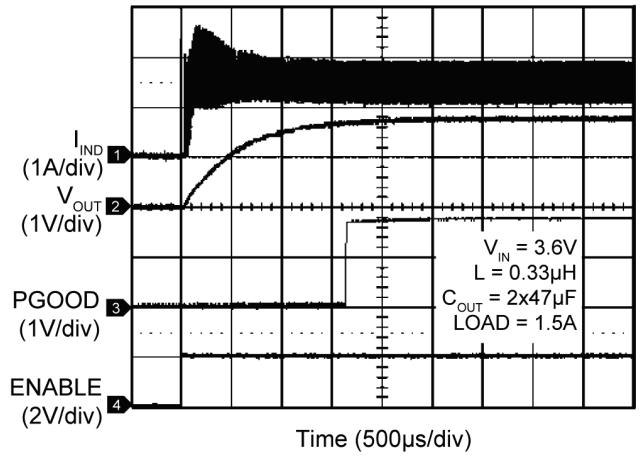

Hot Plug Input Current

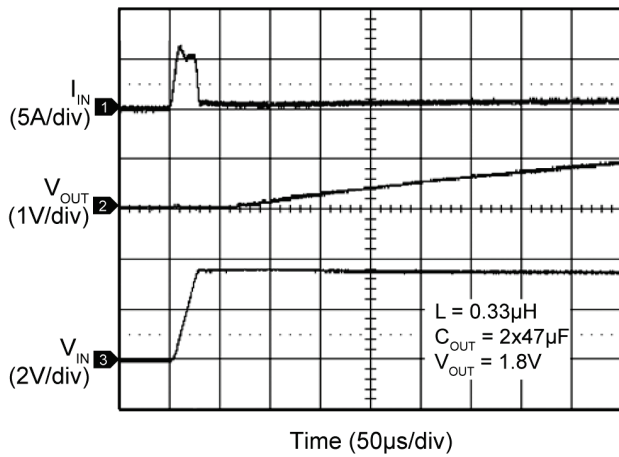

Load Transient 10mA to 200mA

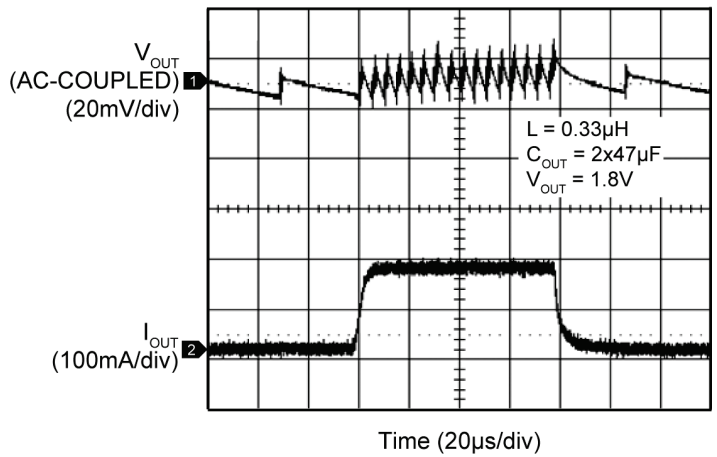

Load Transient 10mA to 500mA

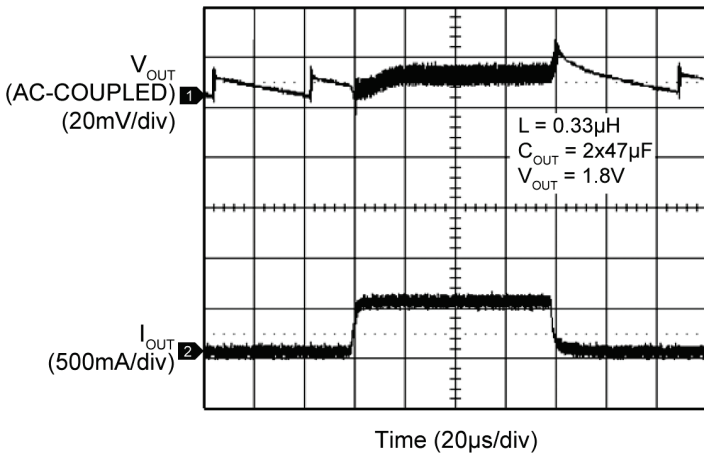

Load Transient 50mA to 1A

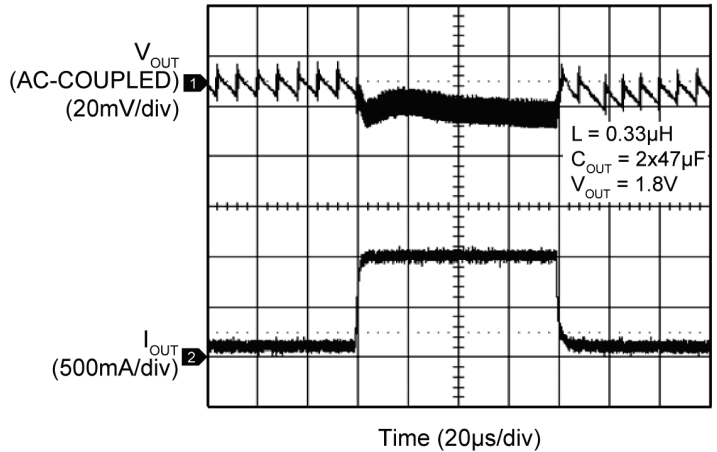

Functional Characteristics (Continued)

**Load Transient
50mA to 2A**

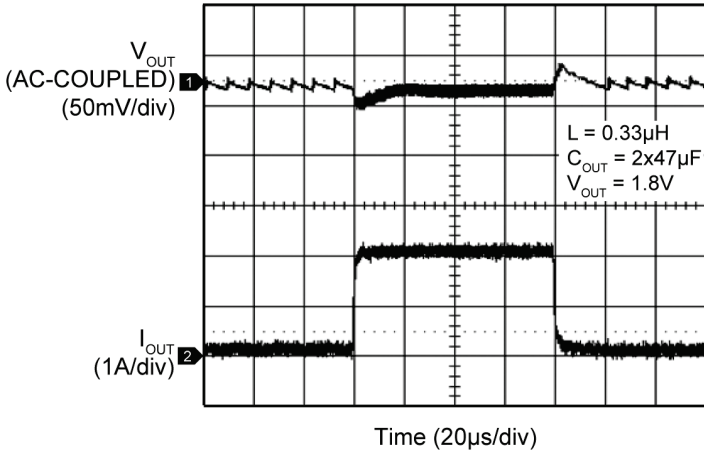

**Load Transient
200mA to 600mA**

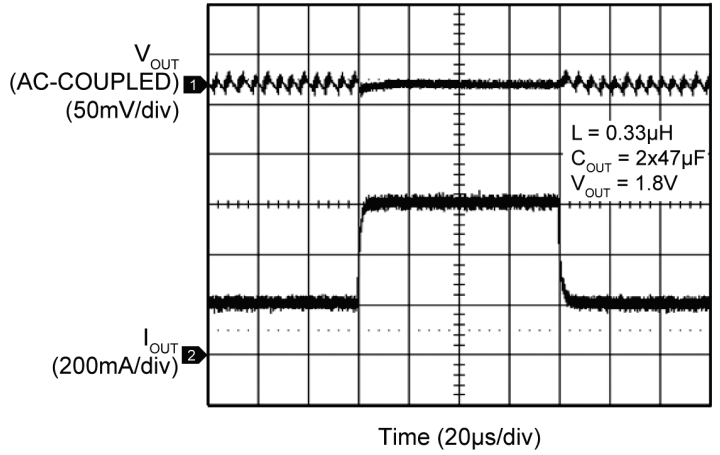

**Load Transient
200mA to 1A**

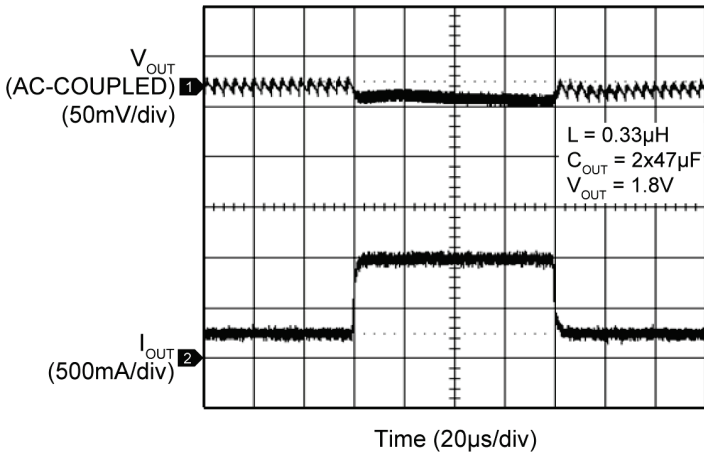

**Load Transient
200mA to 3A**

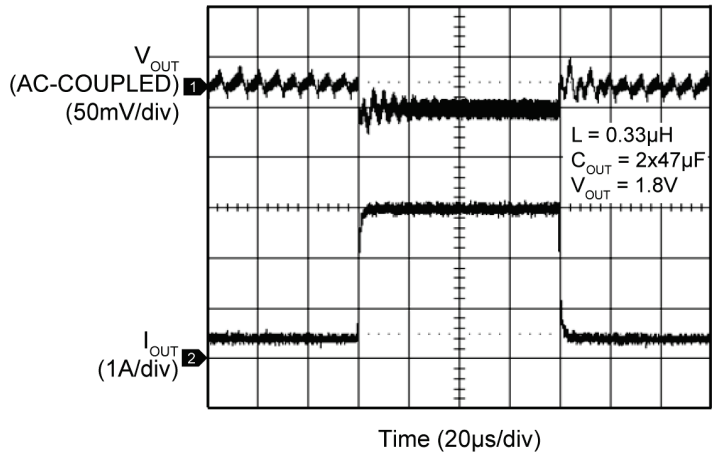

**Load Transient
200mA to 6A**

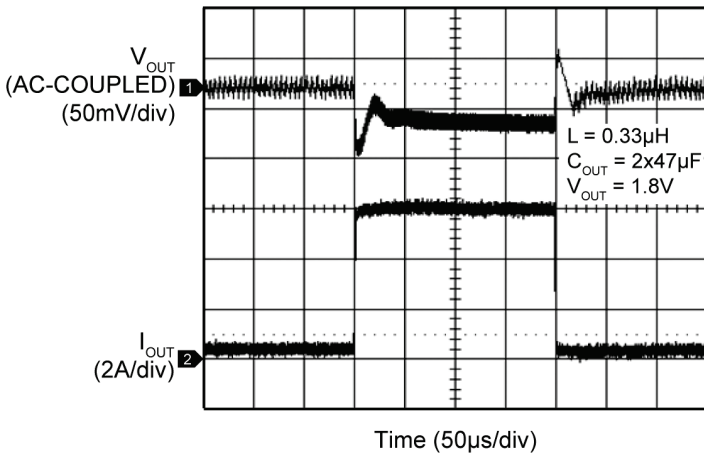

**Line Transient
100mA Load**

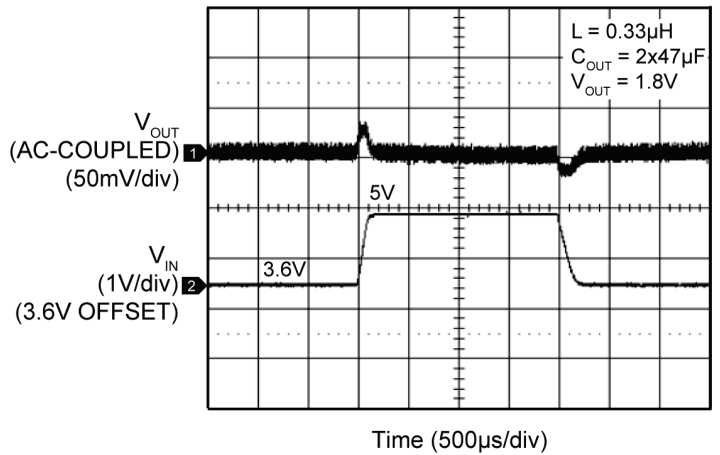

Functional Characteristics (Continued)

Line Transient 6A Load

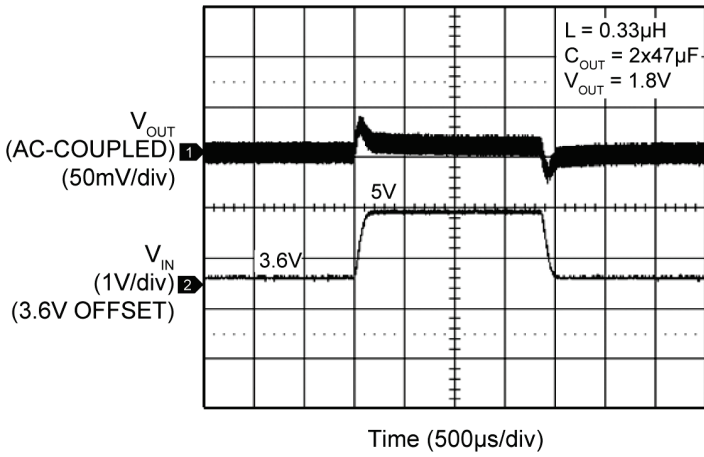

Switching Waveform Discontinuous Mode (1mA)

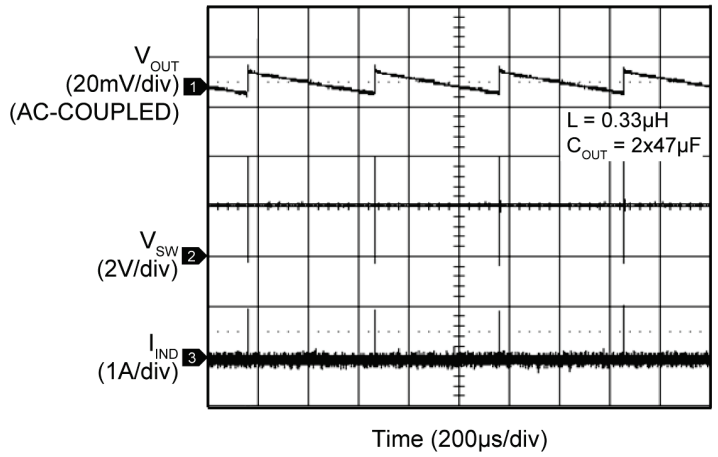

Switching Waveform Discontinuous Mode (10mA)

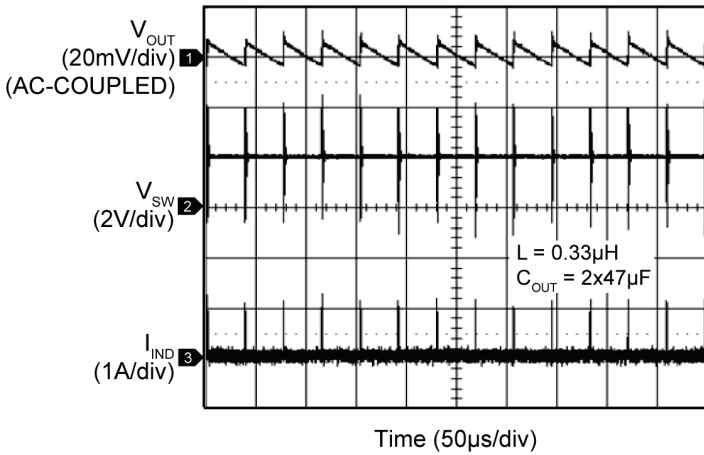

Switching Waveform Discontinuous Mode (50mA)

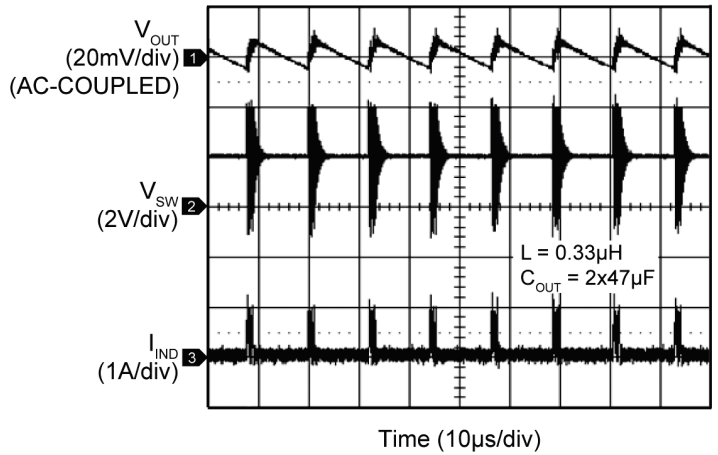

Switching Waveform Continuous Mode (800mA)

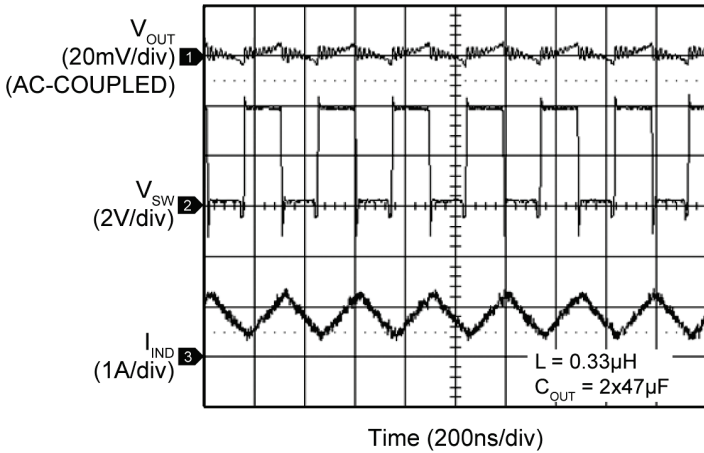

Switching Waveform Continuous Mode (2A)

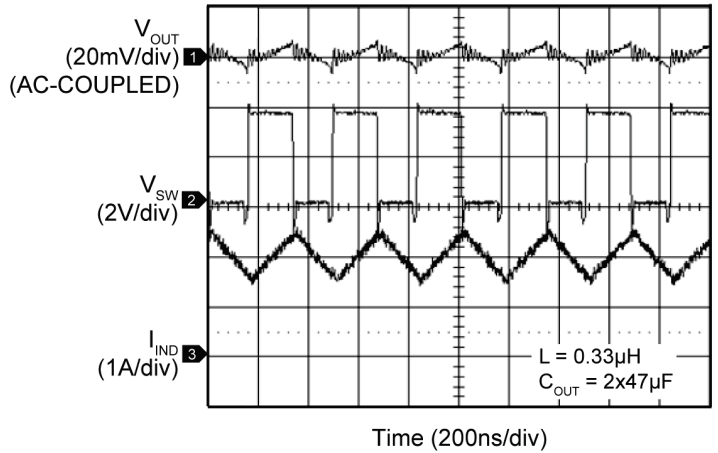

Functional Diagram

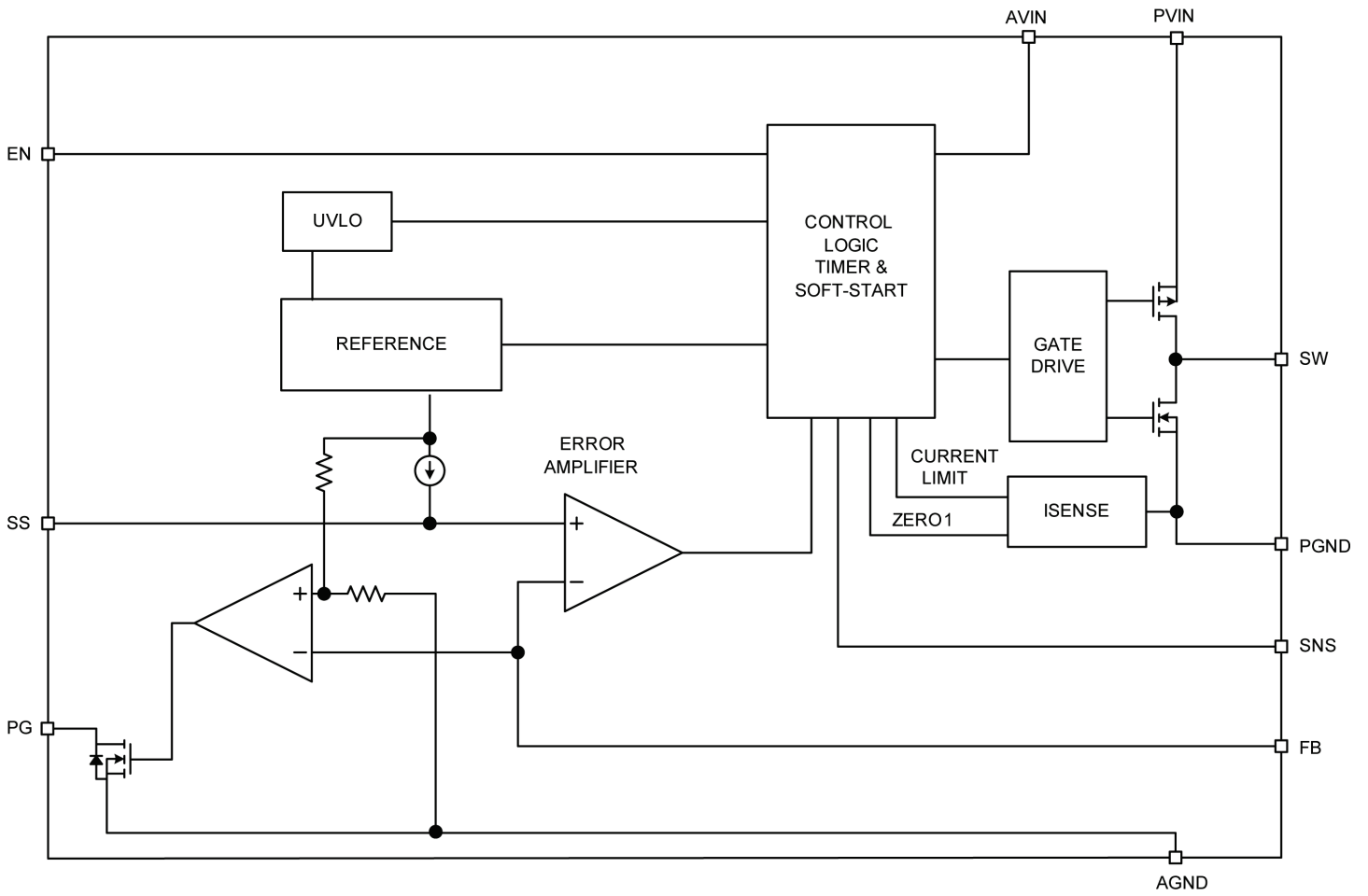

Figure 1. Simplified MIC23603 Functional Block Diagram

Functional Description

PVIN

The input supply (PVIN) provides power to the internal MOSFETs for the switch mode regulator and the driver circuitry. The PVIN operating range is 2.7V to 5.5V, so an input capacitor, with a minimum voltage rating of 6.3V, is recommended. Because of the high switching speed, a minimum 10 μ F bypass capacitor placed close to VIN and the power ground (PGND) pin is required. See the [PCB Layout Recommendations](#) for details.

AVIN

Analog VIN (AVIN) provides power to the internal control and analog circuitry. AVIN and PVIN must be tied together. A 10 Ω resistor is recommended to minimize noise coupling from PVIN. Consider the layout carefully to reduce high frequency switching noise caused by VIN before reaching AVIN. Micrel recommends placing a 1 μ F capacitor as close to AVIN as possible. See [PCB Layout Recommendations](#) for details.

EN

A logic high signal on the enable pin activates the device's output voltage. A logic low signal on the enable pin deactivates the output and reduces supply current to 0.01 μ A. The MIC23603 features built-in soft-start circuitry that reduces inrush current and prevents the output voltage from overshooting at start-up. Do not leave EN floating.

SW

The switch (SW) connects directly to one end of the inductor and provides the current path during switching cycles. The other end of the inductor is connected to the load, SNS pin, and output capacitor. Because of the high speed switching on this pin, route the switch node away from sensitive nodes whenever possible.

SNS

The sense (SNS) pin is connected to the device's output to provide feedback to the control circuitry. Place the SNS connection close to the output capacitor. See [PCB Layout Recommendations](#) for details.

PG

The power good (PG) pin is an open-drain output that indicates logic high when the output voltage is typically above 90% of its steady state voltage. A pull-up resistor of more than 5k Ω should be connected from PG to V_{OUT}.

AGND

The analog ground (AGND) is the ground path for the biasing and control circuitry. The current loop for the signal ground should be separate from the power ground (PGND) loop. See [PCB Layout Recommendations](#) for details. Placing a 3 Ω resistor between AGND and PGND reduces ground noise.

PGND

The power ground pin is the ground path for the high current in PWM mode. The current loop for the power ground should be as small as possible and separate from the analog ground (AGND) loop as applicable. See [PCB Layout Recommendations](#) for details.

SS

The soft start (SS) pin is used to control the output voltage ramp up time. The approximate equation for the ramp time in seconds is $250 \times 10^3 \times \ln(10) \times C_{SS}$.

For example, for $C_{SS} = 2.2\text{nF}$, $T_{\text{rise}} \sim 1.26\text{ms}$. See the [Typical Characteristics](#) curve for a graphical guide. The minimum recommended value for C_{SS} is 2.2nF.

FB

The feedback (FB) pin is provided for the adjustable voltage option (no internal connection for fixed options). This is the control input for programming the output voltage. A resistor divider network is connected to this pin from the output and is compared to the internal 0.62V reference within the regulation loop.

Use Equation 1 to program the output voltage between 0.65V and 3.6V:

$$V_{\text{OUT}} = V_{\text{REF}} \times \left(1 + \frac{R3}{R4} \right) \quad \text{Eq. 1}$$

where: R3 is the top resistor, R4 is the bottom resistor.

V _{OUT}	R3	R4
1.2V	274k Ω	294k Ω
1.5V	316k Ω	221k Ω
1.8V	560k Ω	294k Ω
2.5V	324k Ω	107k Ω
3.3V	464k Ω	107k Ω

Table 1. Example Feedback Resistor Values

Application Information

The MIC23603 is a high-performance DC/DC step down regulator offering a small solution size. Because it supports an output current up to 6A inside a tiny 4mm x 5mm DFN package and requires only three external components, the MIC23603 meets today's miniature portable electronic device needs. Using the HyperLight Load switching scheme, the MIC23603 maintains high efficiency throughout the entire load range while providing ultra-fast load transient response. The following sections provide additional device application information.

Input Capacitor

Place a 10 μ F ceramic capacitor or greater close to the VIN pin and PGND/GND pin for bypassing. Micrel recommends the TDK C1608X5R0J106K, size 0603, 10 μ F ceramic capacitor based upon performance, size, and cost. An X5R or X7R temperature rating is recommended for the input capacitor. Y5V temperature rating capacitors, aside from losing most of their capacitance over temperature, can also become resistive at high frequencies. This reduces their ability to filter out high frequency noise.

Output Capacitor

The MIC23603 was designed for use with a 47 μ F or greater ceramic output capacitor. Increasing the output capacitance lowers output ripple and improves load transient response, but could increase solution size or cost. A low equivalent series resistance (ESR) ceramic output capacitor such as the TDK C3216X6S1A476M, size 1206, 47 μ F ceramic capacitor is recommended based upon performance, size and cost. Both the X7R or X5R temperature rating capacitors are recommended. The Y5V and Z5U temperature rating capacitors are not recommended because of their wide variation in capacitance over temperature and increased resistance at high frequencies.

Inductor Selection

When selecting an inductor, consider the following factors (not necessarily in order of importance):

- Inductance
- Rated current value
- Size requirements
- DC resistance (DCR)

The MIC23603 was designed for use with a 0.33 μ H to 1 μ H inductor. For faster transient response, a 0.33 μ H inductor yields the best result. For lower output ripple, a 1 μ H inductor is recommended.

Maximum current ratings of the inductor are generally given in two methods: permissible DC current and saturation current. Permissible DC current can be rated

either for a 40°C temperature rise or a 10% to 20% loss in inductance. Make sure that the inductor selected can handle the maximum operating current. When saturation current is specified, make sure that there is enough margin so that the peak current does not cause the inductor to saturate. Peak current can be calculated as follows:

$$I_{PEAK} = \left[I_{OUT} + V_{OUT} \left(\frac{1 - V_{OUT}/V_{IN}}{2 \times f \times L} \right) \right] \quad \text{Eq. 2}$$

As Equation 2 shows, the peak inductor current is inversely proportional to the switching frequency and the inductance; the lower the switching frequency or the inductance, the higher the peak current. As input voltage increases, the peak current also increases.

The size of the inductor depends on the requirements of the application. Refer to the [Typical Application Schematic](#) and [Bill of Materials](#) for details.

DC resistance (DCR) is also important. While DCR is inversely proportional to size, it can represent a significant efficiency loss. See [Efficiency Considerations](#).

Compensation

The MIC23603 is designed to be stable with a 0.33 μ H to 1 μ H inductor with a minimum of 47 μ F ceramic (X5R) output capacitor. A feedforward capacitor (C_{FF}) in the range of 33pF to 68pF is recommended across the top feedback resistor to reduce the effects of parasitic capacitance and improve transient performance.

Duty Cycle

The typical maximum duty cycle of the MIC23603 is 80%.

Efficiency Considerations

Efficiency is defined as the amount of useful output power, divided by the amount of power supplied.

$$\text{Efficiency \%} = \left(\frac{V_{OUT} \times I_{OUT}}{V_{IN} \times I_{IN}} \right) \times 100 \quad \text{Eq. 3}$$

Maintaining high efficiency serves two purposes. It reduces power dissipation in the power supply, reducing the need for heat sinks and thermal design considerations, and it reduces current consumption for battery powered applications. Reduced current draw from a battery increases the device's operating time and is critical in hand-held devices.

There are two types of losses in switching converters: DC losses and switching losses. DC losses are simply the power dissipation of I^2R . Power is dissipated in the high side switch during the on cycle. Power loss is equal to the high side MOSFET $R_{DS(ON)}$ multiplied by the Switch Current squared. During the off cycle, the low side N-channel MOSFET conducts, also dissipating power.

Device operating current also reduces efficiency. The product of the quiescent (operating) current and the supply voltage represents another DC loss. The current needed to drive the gates on and off at a constant 4MHz frequency and the switching transitions make up the switching losses.

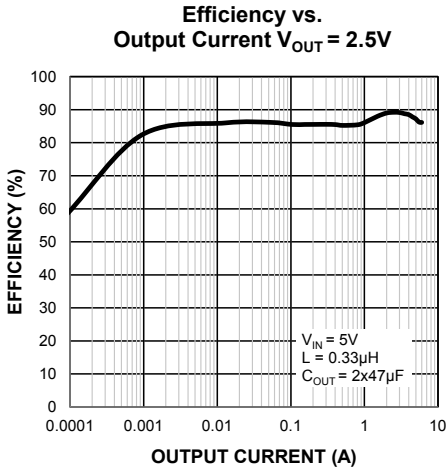

Figure 2. Efficiency Under Load

Figure 2 shows an efficiency curve, from no load to 300mA. Efficiency losses are dominated by quiescent current losses, gate drive, and transition losses. By using the HyperLight Load mode, the MIC23603 can maintain high efficiency at low output currents.

Over 300mA, efficiency loss is dominated by MOSFET $R_{DS(ON)}$ and inductor losses. Higher input supply voltages will increase the Gate-to-Source threshold on the internal MOSFETs, which reduces the internal $R_{DS(ON)}$. This improves efficiency by reducing DC losses in the device. All but the inductor losses are inherent to the device. In this case, inductor selection becomes increasingly critical in efficiency calculations. As the inductors get smaller, the DC resistance (DCR) can become quite significant. The DCR losses can be calculated as follows:

$$P_{DCR} = I_{OUT}^2 \times DCR \quad \text{Eq. 4}$$

From that, the loss in efficiency due to inductor resistance can be calculated as follows:

$$\text{Efficiency Loss} = \left[1 - \left(\frac{V_{OUT} \times I_{OUT}}{V_{OUT} \times I_{OUT} + P_{DCR}} \right) \right] \times 100 \quad \text{Eq. 5}$$

Efficiency loss caused by DCR is minimal at light loads and gains significance as the load is increased. Inductor selection becomes a trade-off between efficiency and size.

HyperLight Load® Mode

MIC23603 uses a minimum on and off time proprietary control loop (patented by Micrel). When the output

voltage falls below the regulation threshold, the error comparator begins a switching cycle that turns the PMOS on and keeps it on for the duration of the minimum-on-time. This increases the output voltage. If the output voltage is over the regulation threshold, then the error comparator turns the PMOS off for a minimum-off-time until the output drops below the threshold. The NMOS acts as an ideal rectifier that conducts when the PMOS is off. Using an NMOS switch instead of a diode allows for lower voltage drop across the switching device when it is on. The asynchronous switching combination between the PMOS and the NMOS allows the control loop to work in discontinuous mode for light load operations. In discontinuous mode, the MIC23603 works in pulse frequency modulation (PFM) to regulate the output. As the output current increases, the off-time decreases, which provides more energy to the output. This switching scheme improves the efficiency of MIC23603 during light load currents by switching only when needed. As the load current increases, the MIC23603 goes into continuous conduction mode (CCM) and switches at a frequency centered at 4MHz. The load when the MIC23603 goes into continuous conduction mode may be approximated by the following formula:

$$I_{LOAD} > \left(\frac{(V_{IN} - V_{OUT}) \times D}{2L \times f} \right) \quad \text{Eq. 6}$$

As shown in the previous equation, the load at which MIC23603 transitions from HyperLight Load mode to PWM mode is a function of the input voltage (V_{IN}), output voltage (V_{OUT}), duty cycle (D), inductance (L), and frequency (f). As shown in Figure 3, as the Output Current increases, the switching frequency also increases, until the MIC23603 goes from HyperLight Load mode to PWM mode at approximately 300mA. The MIC23603 switches a relatively constant frequency around 4MHz after the output current is over 300mA.

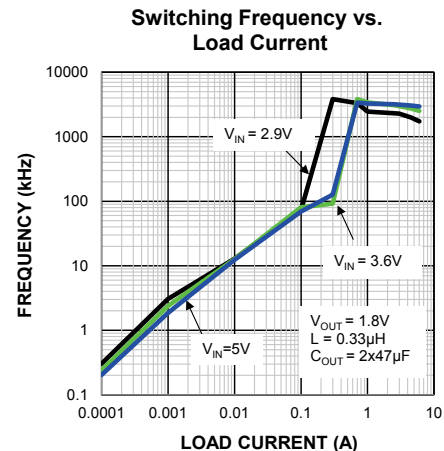
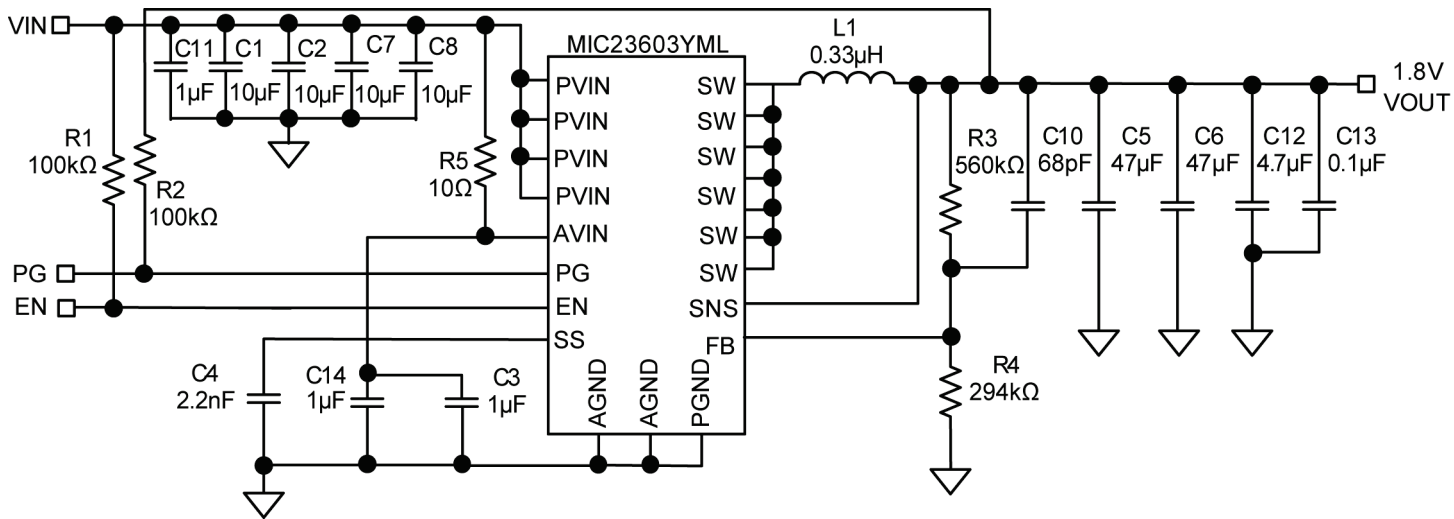

Figure 3. SW Frequency vs. Output Current

Typical Application Schematic



Bill of Materials

Item	Part Number	Manufacturer	Description	Qty
C1, C2, C7, C8	06036D106MAT2A	AVX ⁽¹⁾	10 μ F/6.3V,X5R,0603	4
	GRM188R60J106ME47D	Murata ⁽²⁾		
C3, C11, C14	04026D105KAT2A	AVX	1 μ F/6.3V,X5R,0402	4
	GRM155R60J105KE19D	Murata		
C4	04025A223JAT2A	AVX	2.2nF/50V,0402	1
	GRM1555C1H223JA01D	Murata		
	C1005C0G1H223J	TDK		
C5,C6	12066D476MAT2A	AVX	47 μ F/6.3V,X5R,1206	2
	GRM31CR60J476ME19L	Murata		
C10	04025A680JAT2A	AVX	68pF, 50V, NPO,0402	1
	GRM1555C1H680JZ01D	Murata		
C12	GRM155R60J475ME47D	Murata	4.7 μ F, 6.3V, X5R, 0402	1
	04026D475KAT2A	AVX		
C13	04026C104KAT2A	AVX	0.1 μ F/6.3V,X7R,0402	1
	GRM155R70J104KA01D	Murata		
L1	IHLP2020CZERR33M01	Vishay ⁽³⁾	0.33 μ H, 13.7A, 4.3m Ω	1
	CDMC6D28NP-R30MC	Sumida ⁽⁴⁾	0.3 μ H, 16.1A, 2.7m Ω	
R1, R2	CRCW0402100KFKED	Vishay/Dale	100K, 1%, 1/16W, 0402	2
R3	CRCW0402560KFKEA	Vishay/Dale	560K Ω , 1%, 1/6W, 0402	1
R4	CRCW0402294KFKEA	Vishay/Dale	294K Ω , 1%, 1/10W, 0402	1
R5	CRCW040210R0FKED	Vishay/Dale	10 Ω , 1%, 1/16W, 0402	1
U1	MIC23603YML	Micrel, Inc. ⁽⁵⁾	4MHz PWM 6A Buck Regulator with HyperLight Load [®]	1

Notes:

1. AVX: www.avx.com.
2. Murata: www.murata.com.
3. Vishay: www.vishay.com.
4. Sumida: www.sumida.com.
5. Micrel, Inc.: www.micrel.com.

PCB Layout Recommendations

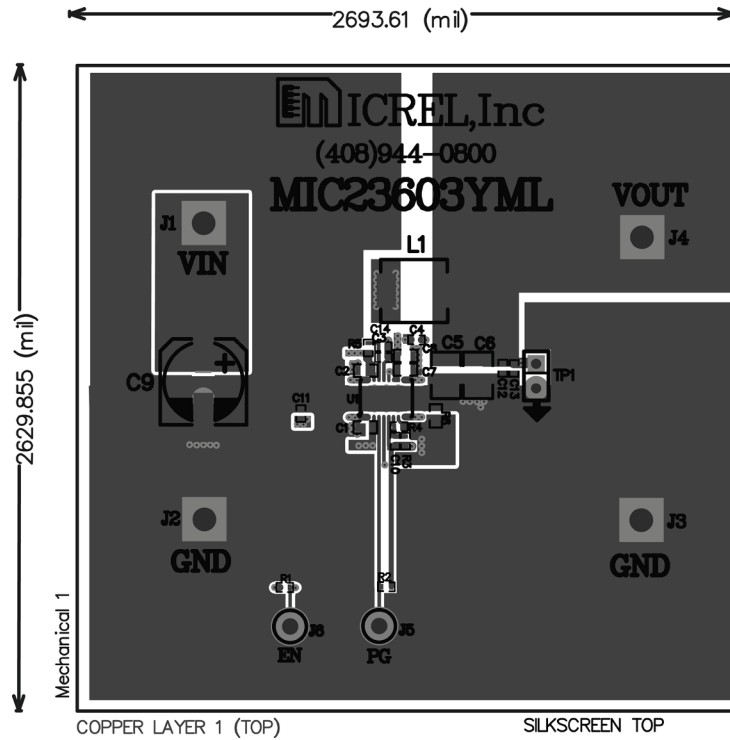

Top Layer

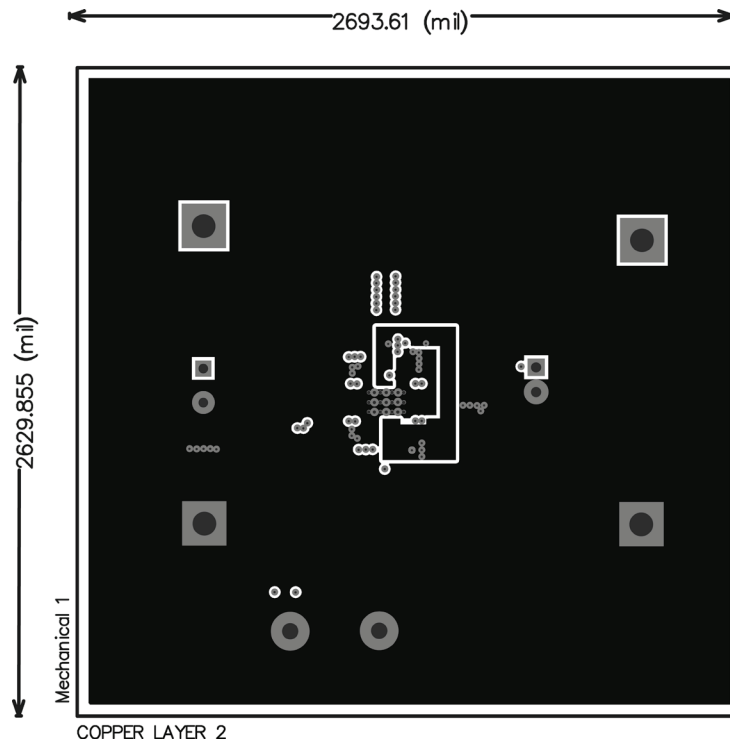

Second Layer

PCB Layout Recommendations (Continued)

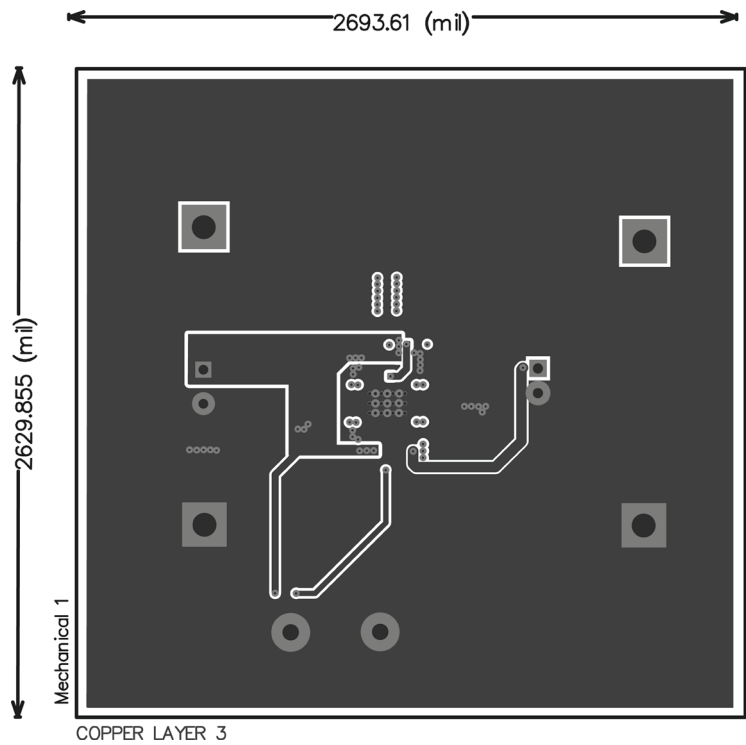

Third Layer

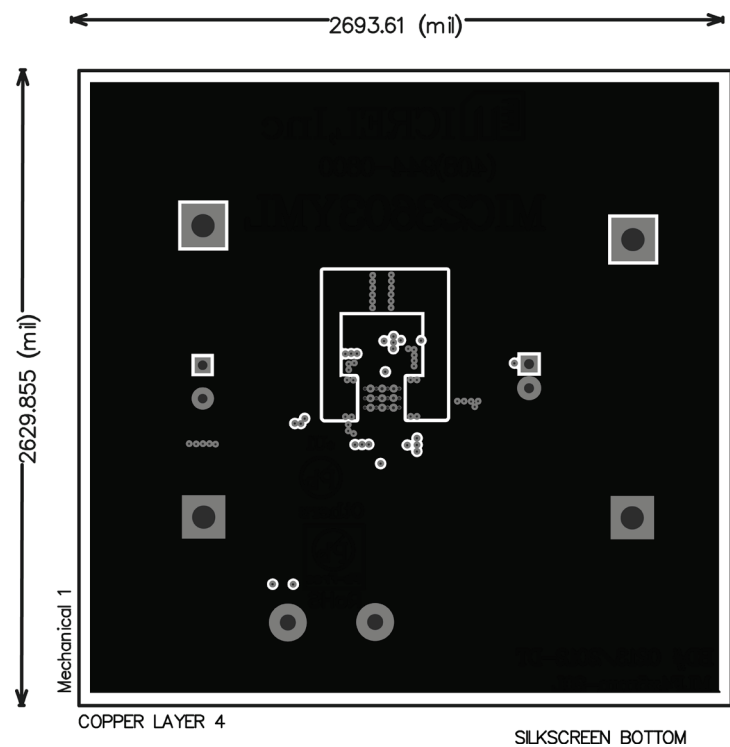

Bottom Layer

Package Information⁽¹⁾

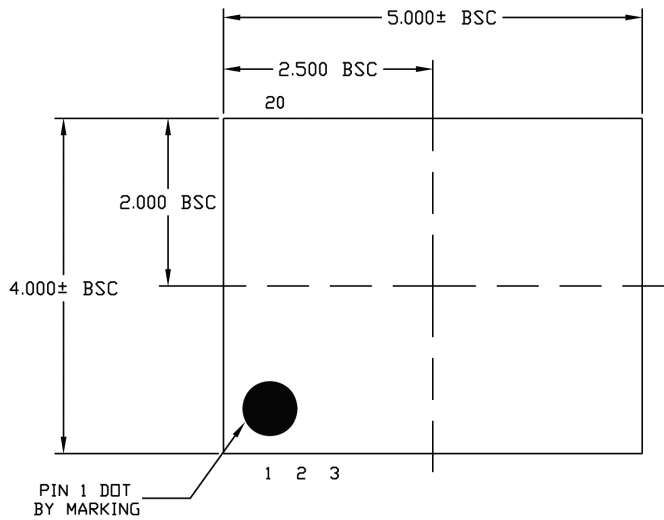

TOP VIEW

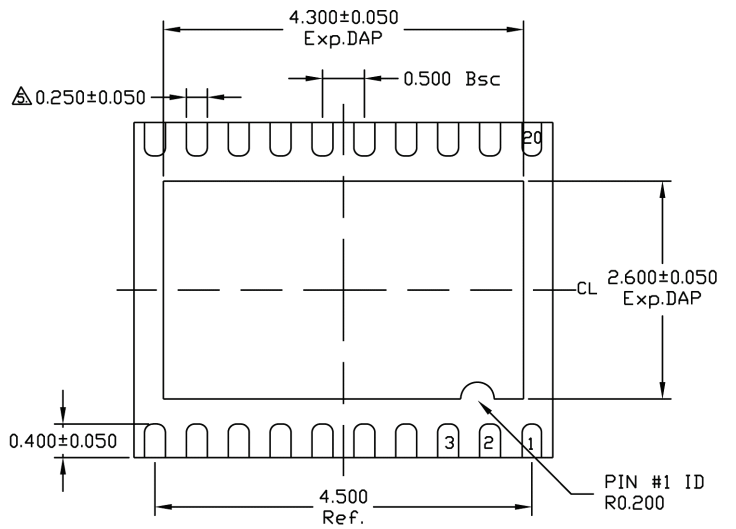

BOTTOM VIEW

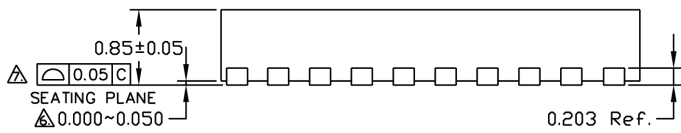

SIDE VIEW

- NOTE:
1. ALL DIMENSIONS ARE IN MILLIMETERS.
 2. MAX. PACKAGE WARPAGE IS 0.05 mm.
 3. MAXIMUM ALLOWABLE BURRS IS 0.076 mm IN ALL DIRECTIONS.
 4. PIN #1 ID ON TOP WILL BE LASER/INK MARKED.
- △ DIMENSION APPLIES TO METALIZED TERMINAL AND IS MEASURED BETWEEN 0.20 AND 0.25 mm FROM TERMINAL TIP.
- △ APPLIED ONLY FOR TERMINALS.
- △ APPLIED FOR EXPOSED PAD AND TERMINALS.

20-Pin 4mm x 5mm DFN (ML)

Note:

1. Package information is correct as of the publication date. For updates and most current information, go to www.micrel.com.

Recommended Land Pattern

All units are in mm
Tolerance ± 0.05 if not noted

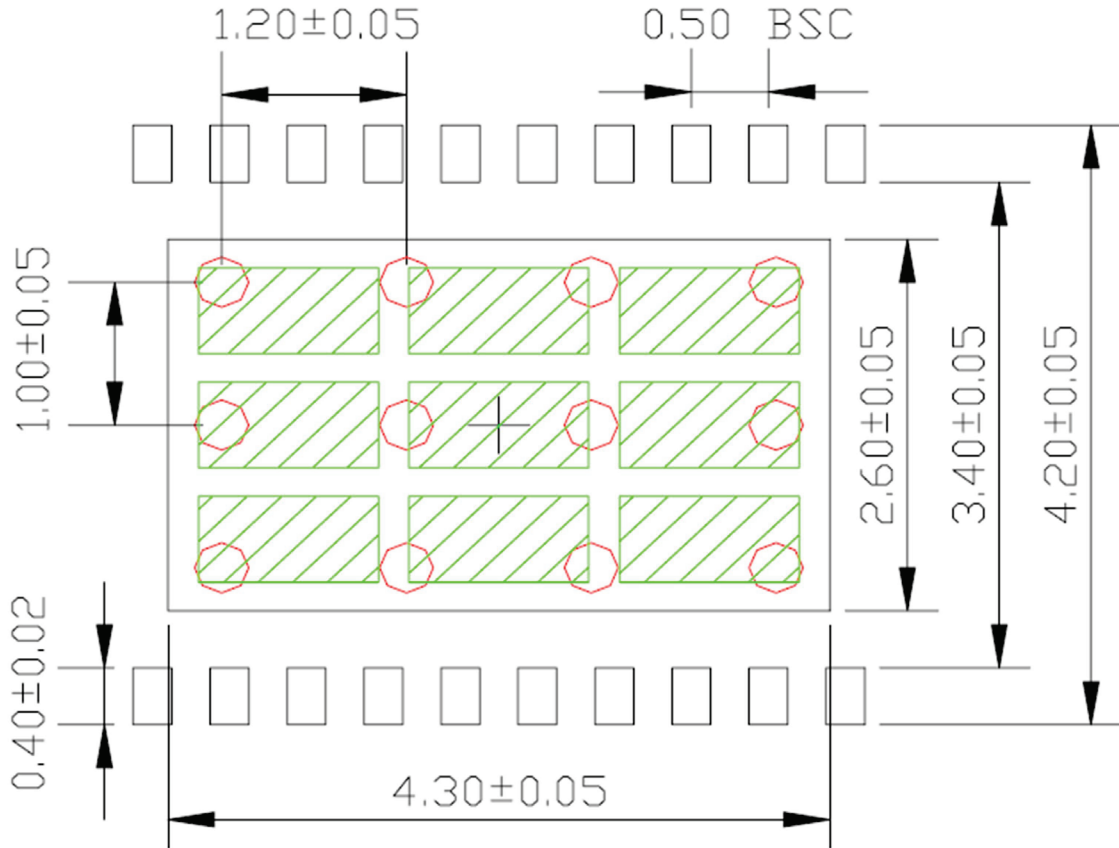

A red circle indicates a Thermal Via. The diameter should be 0.300 to 0.350mm and it should be connected to the GND plane for maximum thermal performance.

A green rectangle (with shaded area) indicates a Solder Stencil Opening on the exposed pad area. The size should be 1.17x0.60mm, 0.80mm pitch.

MICREL, INC. 2180 FORTUNE DRIVE SAN JOSE, CA 95131 USA

TEL +1 (408) 944-0800 FAX +1 (408) 474-1000 WEB <http://www.micrel.com>

Micrel makes no representations or warranties with respect to the accuracy or completeness of the information furnished in this data sheet. This information is not intended as a warranty and Micrel does not assume responsibility for its use. Micrel reserves the right to change circuitry, specifications and descriptions at any time without notice. No license, whether express, implied, arising by estoppel or otherwise, to any intellectual property rights is granted by this document. Except as provided in Micrel's terms and conditions of sale for such products, Micrel assumes no liability whatsoever, and Micrel disclaims any express or implied warranty relating to the sale and/or use of Micrel products including liability or warranties relating to fitness for a particular purpose, merchantability, or infringement of any patent, copyright or other intellectual property right.

Micrel Products are not designed or authorized for use as components in life support appliances, devices or systems where malfunction of a product can reasonably be expected to result in personal injury. Life support devices or systems are devices or systems that (a) are intended for surgical implant into the body or (b) support or sustain life, and whose failure to perform can be reasonably expected to result in a significant injury to the user. A Purchaser's use or sale of Micrel Products for use in life support appliances, devices or systems is a Purchaser's own risk and Purchaser agrees to fully indemnify Micrel for any damages resulting from such use or sale.

© 2013 Micrel, Incorporated.