



**PIC16C55X**

**Data Sheet**

EPROM-Based 8-Bit CMOS

Microcontrollers

---

**Note the following details of the code protection feature on PICmicro® MCUs.**

- The PICmicro family meets the specifications contained in the Microchip Data Sheet.
- Microchip believes that its family of PICmicro microcontrollers is one of the most secure products of its kind on the market today, when used in the intended manner and under normal conditions.
- There are dishonest and possibly illegal methods used to breach the code protection feature. All of these methods, to our knowledge, require using the PICmicro microcontroller in a manner outside the operating specifications contained in the data sheet. The person doing so may be engaged in theft of intellectual property.
- Microchip is willing to work with the customer who is concerned about the integrity of their code.
- Neither Microchip nor any other semiconductor manufacturer can guarantee the security of their code. Code protection does not mean that we are guaranteeing the product as “unbreakable”.
- Code protection is constantly evolving. We at Microchip are committed to continuously improving the code protection features of our product.

If you have any further questions about this matter, please contact the local sales office nearest to you.

---

Information contained in this publication regarding device applications and the like is intended through suggestion only and may be superseded by updates. It is your responsibility to ensure that your application meets with your specifications. No representation or warranty is given and no liability is assumed by Microchip Technology Incorporated with respect to the accuracy or use of such information, or infringement of patents or other intellectual property rights arising from such use or otherwise. Use of Microchip's products as critical components in life support systems is not authorized except with express written approval by Microchip. No licenses are conveyed, implicitly or otherwise, under any intellectual property rights.

#### **Trademarks**

The Microchip name and logo, the Microchip logo, KEELOQ, MPLAB, PIC, PICmicro, PICSTART and PRO MATE are registered trademarks of Microchip Technology Incorporated in the U.S.A. and other countries.


FilterLab, microID, MXDEV, MXLAB, PICMASTER, SEEVAL and The Embedded Control Solutions Company are registered trademarks of Microchip Technology Incorporated in the U.S.A.

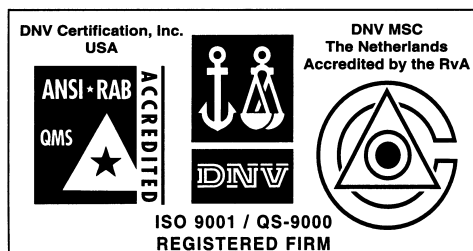
dsPIC, dsPICDEM.net, ECONOMONITOR, FanSense, FlexROM, fuzzyLAB, In-Circuit Serial Programming, ICSP, ICEPIC, microPort, Migratable Memory, MPASM, MPLIB, MPLINK, MPSIM, PICC, PICDEM, PICDEM.net, rPIC, Select Mode and Total Endurance are trademarks of Microchip Technology Incorporated in the U.S.A. and other countries.

Serialized Quick Turn Programming (SQTP) is a service mark of Microchip Technology Incorporated in the U.S.A.

All other trademarks mentioned herein are property of their respective companies.

© 2002, Microchip Technology Incorporated, Printed in the U.S.A., All Rights Reserved.

 Printed on recycled paper.



*Microchip received QS-9000 quality system certification for its worldwide headquarters, design and wafer fabrication facilities in Chandler and Tempe, Arizona in July 1999 and Mountain View, California in March 2002. The Company's quality system processes and procedures are QS-9000 compliant for its PICmicro® 8-bit MCUs, KEELOQ® code hopping devices, Serial EEPROMs, microperipherals, non-volatile memory and analog products. In addition, Microchip's quality system for the design and manufacture of development systems is ISO 9001 certified.*

## EPROM-Based 8-Bit CMOS Microcontrollers

### Devices Included in this Data Sheet:

Referred to collectively as PIC16C55X.

- PIC16C554
- PIC16C557
- PIC16C558

### High Performance RISC CPU:

- Only 35 instructions to learn
- All single-cycle instructions (200 ns), except for program branches which are two-cycle
- Operating speed:
  - DC - 20 MHz clock input
  - DC - 20 ns instruction cycle

Device	Program Memory	Data Memory
PIC16C554	512	80
PIC16C557	2 K	128
PIC16C558	2 K	128

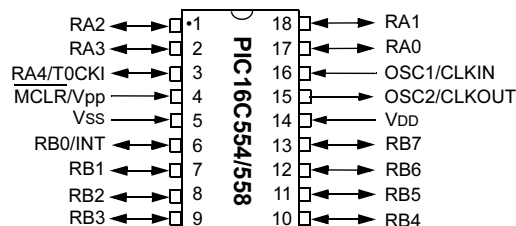
- Interrupt capability
- 16-18 special function hardware registers
- 8-level deep hardware stack
- Direct, Indirect and Relative Addressing modes

### Peripheral Features:

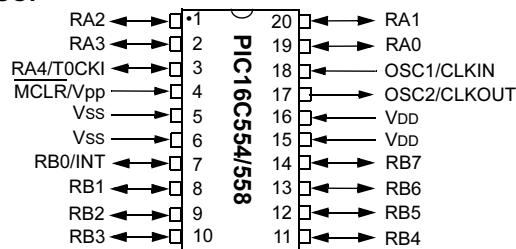
- 13-22 I/O pins with individual direction control
  - Pull-up resistors on PORTB
- High current sink/source for direct LED drive
- Timer0: 8-bit timer/counter with 8-bit programmable prescaler

### Pin Diagram

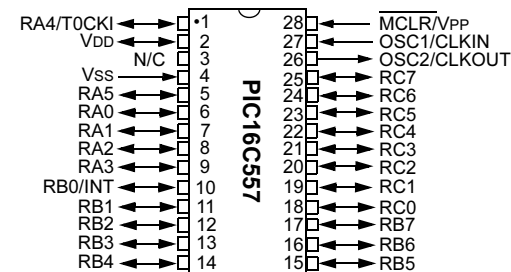
#### PDIP, SOIC, Windowed CERDIP



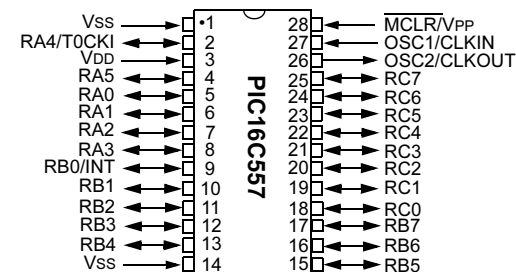
#### SSOP



#### PDIP, SOIC, Windowed CERDIP



#### SSOP



# PIC16C55X

---

---

## Special Microcontroller Features:

- Power-on Reset (POR)
- Power-up Timer (PWRT) and Oscillator Start-up Timer (OST)
- Watchdog Timer (WDT) with its own on-chip RC oscillator for reliable operation
- Programmable code protection
- Power saving SLEEP mode
- Selectable oscillator options
- Serial in-circuit programming (via two pins)
- Four user programmable ID locations

**Note:** For additional information on enhancements, see Appendix A

## CMOS Technology:

- Low power, high speed CMOS EPROM technology
- Fully static design
- Wide operating voltage range
  - 2.5V to 5.5V
- Commercial, Industrial and Extended temperature range
- Low power consumption
  - < 2.0 mA @ 5.0V, 4.0 MHz
  - 15  $\mu$ A typical 3.0V, 32 kHz
  - < 1.0  $\mu$ A typical standby current @ 3.0V

## Device Differences

Device	Voltage Range	Oscillator
PIC16C554	2.5 - 5.5	(Note 1)
PIC16C557	2.5 - 5.5	(Note 1)
PIC16C558	2.5 - 5.5	(Note 1)

**Note 1:** If you change from this device to another device, please verify oscillator characteristics in your application.

## Table of Contents

1.0	General Description.....	5
2.0	PIC16C55X Device Varieties .....	7
3.0	Architectural Overview .....	9
4.0	Memory Organization .....	13
5.0	I/O Ports .....	23
6.0	Special Features of the CPU.....	31
7.0	Timer0 Module .....	47
8.0	Instruction Set Summary .....	53
9.0	Development Support.....	67
10.0	Electrical Specifications.....	73
11.0	Packaging Information.....	87
Appendix A:	Enhancements.....	97
Appendix B:	Compatibility .....	97
Index .....		99
On-Line Support.....		101
Systems Information and Upgrade Hot Line .....		101
Reader Response .....		102
Product Identification System .....		103

## TO OUR VALUED CUSTOMERS

It is our intention to provide our valued customers with the best documentation possible to ensure successful use of your Microchip products. To this end, we will continue to improve our publications to better suit your needs. Our publications will be refined and enhanced as new volumes and updates are introduced.

If you have any questions or comments regarding this publication, please contact the Marketing Communications Department via E-mail at [docerrors@mail.microchip.com](mailto:docerrors@mail.microchip.com) or fax the **Reader Response Form** in the back of this data sheet to (480) 792-4150. We welcome your feedback.

### Most Current Data Sheet

To obtain the most up-to-date version of this data sheet, please register at our Worldwide Web site at:

<http://www.microchip.com>

You can determine the version of a data sheet by examining its literature number found on the bottom outside corner of any page. The last character of the literature number is the version number, (e.g., DS30000A is version A of document DS30000).

### Errata

An errata sheet, describing minor operational differences from the data sheet and recommended workarounds, may exist for current devices. As device/documentation issues become known to us, we will publish an errata sheet. The errata will specify the revision of silicon and revision of document to which it applies.

To determine if an errata sheet exists for a particular device, please check with one of the following:

- Microchip's Worldwide Web site; <http://www.microchip.com>
- Your local Microchip sales office (see last page)
- The Microchip Corporate Literature Center; U.S. FAX: (480) 792-7277

When contacting a sales office or the literature center, please specify which device, revision of silicon and data sheet (include literature number) you are using.

### Customer Notification System

Register on our web site at [www.microchip.com/cn](http://www.microchip.com/cn) to receive the most current information on all of our products.

# PIC16C55X

---

---

NOTES:

## 1.0 GENERAL DESCRIPTION

The PIC16C55X are 18, 20 and 28-Pin EPROM-based members of the versatile PIC16CXX family of low cost, high performance, CMOS, fully-static, 8-bit microcontrollers.

All PICmicro<sup>®</sup> microcontrollers employ an advanced RISC architecture. The PIC16C55X have enhanced core features, eight-level deep stack, and multiple internal and external interrupt sources. The separate instruction and data buses of the Harvard architecture allow a 14-bit wide instruction word with the separate 8-bit wide data. The two-stage instruction pipeline allows all instructions to execute in a single-cycle, except for program branches (which require two cycles). A total of 35 instructions (reduced instruction set) are available. Additionally, a large register set gives some of the architectural innovations used to achieve a very high performance.

PIC16C55X microcontrollers typically achieve a 2:1 code compression and a 4:1 speed improvement over other 8-bit microcontrollers in their class.

The PIC16C554 has 80 bytes of RAM. The PIC16C557 and PIC16C558 have 128 bytes of RAM. The PIC16C554 and PIC16C558 have 13 I/O pins and an 8-bit timer/counter with an 8-bit programmable prescaler. The PIC16C557 has 22 I/O pins and an 8-bit timer/counter with an 8-bit programmable prescaler.

PIC16C55X devices have special features to reduce external components, thus reducing cost, enhancing system reliability and reducing power consumption. There are four oscillator options, of which the single pin RC oscillator provides a low cost solution, the LP oscillator minimizes power consumption, XT is a standard crystal, and the HS is for high speed crystals. The SLEEP (power-down) mode offers power saving. The user can wake-up the chip from SLEEP through several external and internal interrupts and RESET.

A highly reliable Watchdog Timer, with its own on-chip RC oscillator, provides protection against software lock-up.

A UV-erasable CERDIP packaged version is ideal for code development while the cost effective One-Time Programmable (OTP) version is suitable for production in any volume.

Table 1-1 shows the features of the PIC16C55X mid-range microcontroller families.

A simplified block diagram of the PIC16C55X is shown in Figure 3-1.

The PIC16C55X series fit perfectly in applications ranging from motor control to low power remote sensors. The EPROM technology makes customization of application programs (detection levels, pulse generation, timers, etc.) extremely fast and convenient. The small footprint packages make this microcontroller series perfect for all applications with space limitations. Low cost, low power, high performance, ease of use and I/O flexibility make the PIC16C55X very versatile.

### 1.1 Family and Upward Compatibility

Users familiar with the PIC16C5X family of microcontrollers will realize that this is an enhanced version of the PIC16C5X architecture. Please refer to Appendix A for a detailed list of enhancements. Code written for PIC16C5X can be easily ported to PIC16C55X family of devices (Appendix B).

The PIC16C55X family fills the niche for users wanting to migrate up from the PIC16C5X family and not needing various peripheral features of other members of the PIC16XX mid-range microcontroller family.

### 1.2 Development Support

The PIC16C55X family is supported by a full-featured macro assembler, a software simulator, an in-circuit emulator, a low cost development programmer and a full-featured programmer.

# PIC16C55X

TABLE 1-1: PIC16C55X FAMILY OF DEVICES

		PIC16C554	PIC16C557	PIC16C558
<b>Clock</b>	Maximum Frequency of Operation (MHz)	20	20	20
<b>Memory</b>	EPROM Program Memory (x14 words)	512	2K	2K
	Data Memory (bytes)	80	128	128
<b>Peripherals</b>	Timer Module(s)	TMR0	TMR0	TMR0
<b>Features</b>	Interrupt Sources	3	3	3
	I/O Pins	13	22	13
	Voltage Range (Volts)	2.5-5.5	2.5-5.5	2.5-5.5
	Brown-out Reset	—	—	—
	Packages	18-pin DIP, SOIC; 20-pin SSOP	28-pin DIP, SOIC; 28-pin SSOP	18-pin DIP, SOIC, SSOP

All PICmicro® Family devices have Power-on Reset, selectable Watchdog Timer, selectable code protect and high I/O current capability. All PIC16C55X Family devices use serial programming with clock pin RB6 and data pin RB7.



## 2.0 PIC16C55X DEVICE VARIETIES

A variety of frequency ranges and packaging options are available. Depending on application and production requirements, the proper device option can be selected using the information in the PIC16C55X Product Identification System section at the end of this data sheet. When placing orders, please use this page of the data sheet to specify the correct part number.

### 2.1 UV Erasable Devices

The UV erasable version, offered in CERDIP package, is optimal for prototype development and pilot programs. This version can be erased and reprogrammed to any of the oscillator modes.

Microchip's PICSTART<sup>®</sup> and PROMATE<sup>®</sup> programmers both support programming of the PIC16C55X.

### 2.2 One-Time Programmable (OTP) Devices

The availability of OTP devices is especially useful for customers who need the flexibility for frequent code updates and small volume applications. In addition to the program memory, the configuration bits must also be programmed.

### 2.3 Quick-Turnaround Production (QTP) Devices

Microchip offers a QTP Programming Service for factory production orders. This service is made available for users who choose not to program a medium-to-high quantity of units and whose code patterns have stabilized. The devices are identical to the OTP devices, but with all EPROM locations and configuration options already programmed by the factory. Certain code and prototype verification procedures apply before production shipments are available. Please contact your Microchip Technology sales office for more details.

### 2.4 Serialized Quick-Turnaround Production (SQTP<sup>SM</sup>) Devices

Microchip offers a unique programming service where a few user-defined locations in each device are programmed with different serial numbers. The serial numbers may be random, pseudo-random or sequential.

Serial programming allows each device to have a unique number which can serve as an entry code, password or ID number.

# PIC16C55X

---

NOTES:

## 3.0 ARCHITECTURAL OVERVIEW

The high performance of the PIC16C55X family can be attributed to a number of architectural features commonly found in RISC microprocessors. To begin with, the PIC16C55X uses a Harvard architecture in which program and data are accessed from separate memories using separate busses. This improves bandwidth over traditional von Neumann architecture where program and data are fetched from the same memory. Separating program and data memory further allows instructions to be sized differently from 8-bit wide data words. Instruction opcodes are 14-bit wide making it possible to have all single word instructions. A 14-bit wide program memory access bus fetches a 14-bit instruction in a single cycle. A two-stage pipeline overlaps fetch and execution of instructions. Consequently, all instructions (35) execute in a single-cycle (200 ns @ 20 MHz) except for program branches. The table below lists the memory (EPROM and RAM).

Device	Program Memory (EPROM)	Data Memor (RAM)
PIC16C554	512	80
PIC16C557	2 K	128
PIC16C558	2 K	128

The PIC16C554 addresses 512 x 14 on-chip program memory. The PIC16C557 and PIC16C558 addresses 2 K x 14 program memory. All program memory is internal.

The PIC16C55X can directly or indirectly address its register files or data memory. All special function registers, including the program counter, are mapped into the data memory. The PIC16C55X has an orthogonal (symmetrical) instruction set that makes it possible to carry out any operation on any register using any Addressing mode. This symmetrical nature and lack of 'special optimal situations' make programming with the PIC16C55X simple yet efficient. In addition, the learning curve is reduced significantly.

The PIC16C55X devices contain an 8-bit ALU and working register. The ALU is a general purpose arithmetic unit. It performs arithmetic and Boolean functions between data in the working register and any register file.

The ALU is 8-bits wide and capable of addition, subtraction, shift and logical operations. Unless otherwise mentioned, arithmetic operations are two's complement in nature. In two-operand instructions, typically one operand is the working register (W register). The other operand is a file register or an immediate constant. In single operand instructions, the operand is either the W register or a file register.

The W register is an 8-bit working register used for ALU operations. It is not an addressable register.

Depending on the instruction executed, the ALU may affect the values of the Carry (C), Digit Carry (DC), and Zero (Z) bits in the STATUS register. The C and DC bits operate as a Borrow and Digit Borrow out bit, respectively, in subtraction. See the `SUBLW` and `SUBWF` instructions for examples.

A simplified block diagram is shown in Figure 3-1, with a description of the device pins in Table 3-1.



**TABLE 3-1: PIC16C55X PINOUT DESCRIPTION**

Name	Pin Number			Pin Type	Buffer Type	Description
	PDIP	SOIC	SSOP			
OSC1/CLKIN	16	16	18	I	ST/CMOS	Oscillator crystal input/external clock source output.
OSC2/CLKOUT	15	15	17	O	—	Oscillator crystal output. Connects to crystal or resonator in Crystal Oscillator mode. In RC mode, OSC2 pin outputs CLKOUT which has 1/4 the frequency of OSC1, and denotes the instruction cycle rate.
MCLR/VPP	4	4	4	I/P	ST	Master clear (Reset) input/programming voltage input. This pin is an active low RESET to the device.
RA0	17	17	19	I/O	ST	Bi-directional I/O port
RA1	18	18	20	I/O	ST	Bi-directional I/O port
RA2	1	1	1	I/O	ST	Bi-directional I/O port
RA3	2	2	2	I/O	ST	Bi-directional I/O port
RA4/T0CKI	3	3	3	I/O	ST	Bi-directional I/O port or external clock input for TMR0. Output is open drain type.
RB0/INT	6	6	7	I/O	TTL/ST <sup>(1)</sup>	Bi-directional I/O port can be software programmed for internal weak pull-up. RB0/INT can also be selected as an external interrupt pin.
RB1	7	7	8	I/O	TTL	Bi-directional I/O port can be software programmed for internal weak pull-up.
RB2	8	8	9	I/O	TTL	Bi-directional I/O port can be software programmed for internal weak pull-up.
RB3	9	9	10	I/O	TTL	Bi-directional I/O port can be software programmed for internal weak pull-up.
RB4	10	10	11	I/O	TTL	Bi-directional I/O port can be software programmed for internal weak pull-up. Interrupt-on-change pin.
RB5	11	11	12	I/O	TTL	Bi-directional I/O port can be software programmed for internal weak pull-up. Interrupt-on-change pin.
RB6	12	12	13	I/O	TTL/ST <sup>(2)</sup>	Bi-directional I/O port can be software programmed for internal weak pull-up. Interrupt-on-change pin. Serial programming clock.
RB7	13	13	14	I/O	TTL/ST <sup>(2)</sup>	Bi-directional I/O port can be software programmed for internal weak pull-up. Interrupt-on-change pin. Serial programming data.
RC0 <sup>(3)</sup>	18	18	18	I/O	TTL	Bi-directional I/O port input buffer.
RC1 <sup>(3)</sup>	19	19	19	I/O	TTL	Bi-directional I/O port input buffer.
RC2 <sup>(3)</sup>	20	20	20	I/O	TTL	Bi-directional I/O port input buffer.
RC3 <sup>(3)</sup>	21	21	21	I/O	TTL	Bi-directional I/O port input buffer.
RC4 <sup>(3)</sup>	22	22	22	I/O	TTL	Bi-directional I/O port input buffer.
RC5 <sup>(3)</sup>	23	23	23	I/O	TTL	Bi-directional I/O port input buffer.
RC6 <sup>(3)</sup>	24	24	24	I/O	TTL	Bi-directional I/O port input buffer.
RC7 <sup>(3)</sup>	25	25	25	I/O	TTL	Bi-directional I/O port input buffer.
Vss	5	5	5,6	P	—	Ground reference for logic and I/O pins.
VDD	14	14	15,16	P	—	Positive supply for logic and I/O pins.

Legend:                    O = Output                    I/O = Input/output                    P = Power  
                               — = Not used                    I = Input                                ST = Schmitt Trigger input  
                               TTL = TTL input

- Note 1:** This buffer is a Schmitt Trigger input when configured as the external interrupt.  
**Note 2:** This buffer is a Schmitt Trigger input when used in Serial Programming mode.  
**Note 3:** PIC16C557 only.

# PIC16C55X

## 3.1 Clocking Scheme/Instruction Cycle

The clock input (OSC1/CLKIN pin) is internally divided by four to generate four non-overlapping quadrature clocks namely Q1, Q2, Q3 and Q4. Internally, the program counter (PC) is incremented every Q1, the instruction is fetched from the program memory and latched into the instruction register in Q4. The instruction is decoded and executed during the following Q1 through Q4. The clocks and instruction execution flow are shown in Figure 3-2.

## 3.2 Instruction Flow/Pipelining

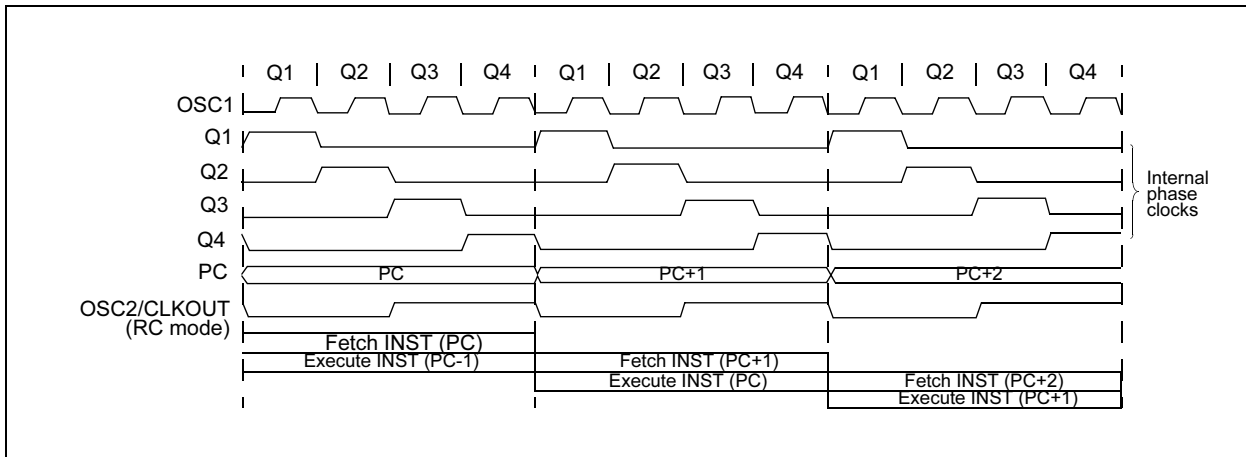
An "Instruction Cycle" consists of four Q cycles (Q1, Q2, Q3 and Q4). The instruction fetch and execute are pipelined such that fetch takes one instruction cycle

while decode and execute takes another instruction cycle. However, due to the pipelining, each instruction effectively executes in one cycle. If an instruction causes the program counter to change (e.g., GOTO), then two cycles are required to complete the instruction (Example 3-1).

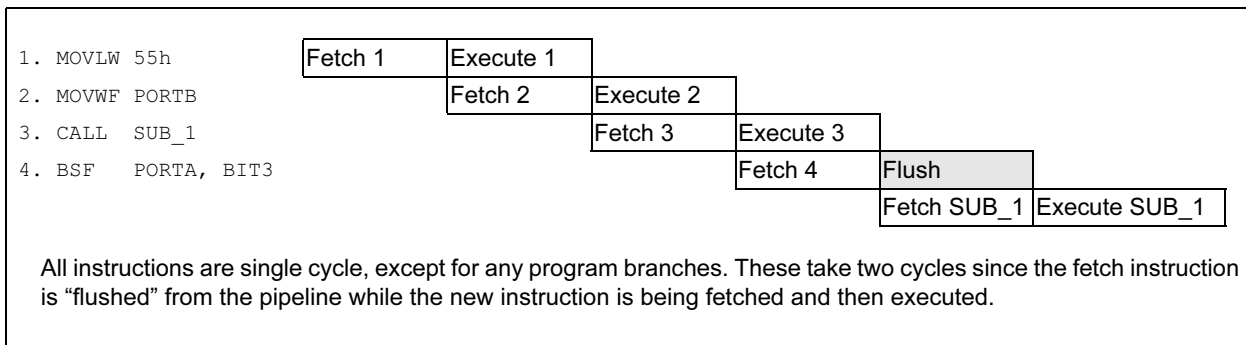
A fetch cycle begins with the program counter (PC) incrementing in Q1.

In the execution cycle, the fetched instruction is latched into the "Instruction Register (IR)" in cycle Q1. This instruction is then decoded and executed during the Q2, Q3, and Q4 cycles. Data memory is read during Q2 (operand read) and written during Q4 (destination write).

**FIGURE 3-2: CLOCK/INSTRUCTION CYCLE**



**EXAMPLE 3-1: INSTRUCTION PIPELINE FLOW**

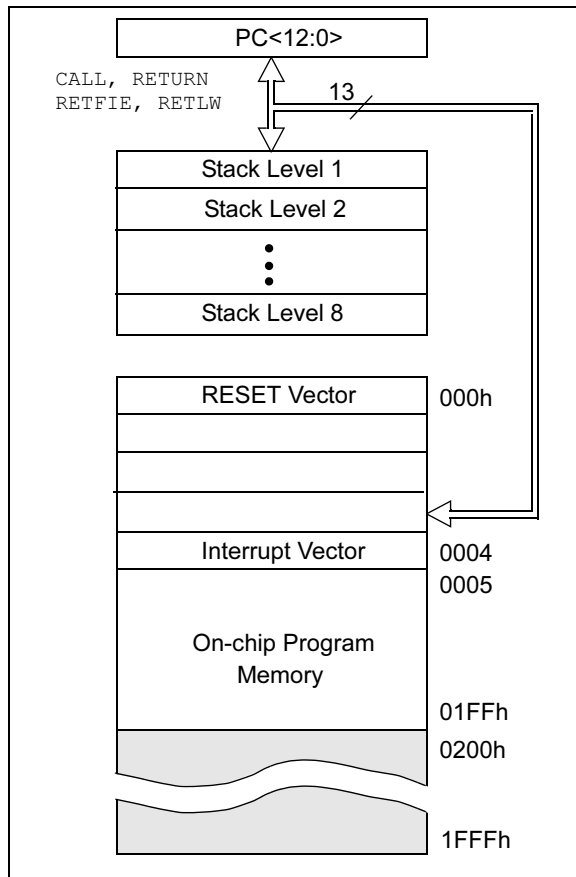


## 4.0 MEMORY ORGANIZATION

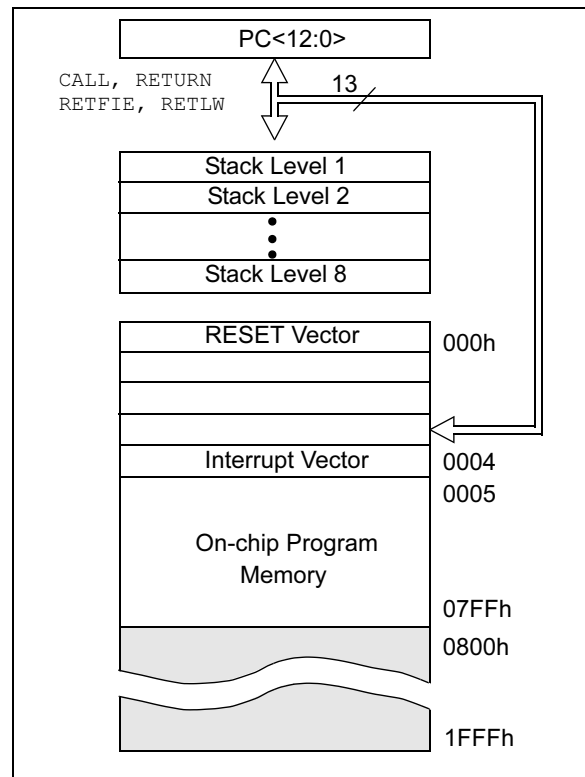
### 4.1 Program Memory Organization

The PIC16C55X has a 13-bit program counter capable of addressing an 8 K x 14 program memory space. Only the first 512 x 14 (0000h - 01FFh) for the PIC16C554 and 2K x 14 (0000h - 07FFh) for the PIC16C557 and PIC16C558 are physically implemented. Accessing a location above these boundaries will cause a wrap-around within the first 512 x 14 spaces in the PIC16C554, or 2K x 14 space of the PIC16C558 and PIC16C557. The RESET vector is at 0000h and the interrupt vector is at 0004h (Figure 4-1, Figure 4-2).

**FIGURE 4-1: PROGRAM MEMORY MAP AND STACK FOR THE PIC16C554**



**FIGURE 4-2: PROGRAM MEMORY MAP AND STACK FOR THE PIC16C557 AND PIC16C558**



### 4.2 Data Memory Organization

The data memory (Figure 4-3 through Figure 4-5) is partitioned into two banks which contain the General Purpose Registers (GPR) and the Special Function Registers (SFR). Bank 0 is selected when the RP0 bit (STATUS <5>) is cleared. Bank 1 is selected when the RP0 bit is set. The Special Function Registers are located in the first 32 locations of each Bank. Register locations 20-6Fh (Bank 0) on the PIC16C554 and 20-7Fh (Bank 0) and A0-BFh (Bank 1) on the PIC16C558 and PIC16C557 are General Purpose Registers implemented as static RAM. Some special purpose registers are mapped in Bank 1.

#### 4.2.1 GENERAL PURPOSE REGISTER FILE

The register file is organized as 80 x 8 in the PIC16C554 and 128 x 8 in the PIC16C557 and PIC16C558. Each can be accessed either directly or indirectly through the File Select Register, FSR (Section 4.4).





**FIGURE 4-5: DATA MEMORY MAP FOR THE PIC16C558**

File Address			File Address
00h	INDF <sup>(1)</sup>	INDF <sup>(1)</sup>	80h
01h	TMR0	OPTION	81h
02h	PCL	PCL	82h
03h	STATUS	STATUS	83h
04h	FSR	FSR	84h
05h	PORTA	TRISA	85h
06h	PORTB	TRISB	86h
07h			87h
08h			88h
09h			89h
0Ah	PCLATH	PCLATH	8Ah
0Bh	INTCON	INTCON	8Bh
0Ch			8Ch
0Dh			8Dh
0Eh		PCON	8Eh
0Fh			8Fh
10h			90h
11h			91h
12h			92h
13h			93h
14h			94h
15h			95h
16h			96h
17h			97h
18h			98h
19h			99h
1Ah			9Ah
1Bh			9Bh
1Ch			9Ch
1Dh			9Dh
1Eh			9Eh
1Fh			9Fh
20h	General Purpose Register	General Purpose Register	A0h
			BFh
			C0h
	~~~~~		
7Fh	Bank 0	Bank 1	FFh

Unimplemented data memory locations, read as '0'.  
**Note 1:** Not a physical register.

## 4.2.2 SPECIAL FUNCTION REGISTERS

The Special Function Registers are registers used by the CPU and peripheral functions for controlling the desired operation of the device (Table 4-1). These registers are static RAM.

The Special Function Registers can be classified into two sets (core and peripheral). The special function registers associated with the “core” functions are described in this section. Those related to the operation of the peripheral features are described in the section of that peripheral feature.

# PIC16C55X

**TABLE 4-1: SPECIAL REGISTERS FOR THE PIC16C55X**

Address	Name	Bit 7	Bit 6	Bit 5	Bit 4	Bit 3	Bit 2	Bit 1	Bit 0	Value on POR Reset	Detail on Page:
<b>Bank 0</b>											
00h	INDF	Addressing this location uses contents of FSR to address data memory (not a physical register)								xxxx xxxx	21
01h	TMR0	Timer0 Module's Register								xxxx xxxx	47
02h	PCL	Program Counter's (PC) Least Significant Byte								0000 0000	21
03h	STATUS	IRP <sup>(2)</sup>	RP1 <sup>(2)</sup>	RP0	$\overline{TO}$	$\overline{PD}$	Z	DC	C	0001 1xxx	17
04h	FSR	Indirect data memory address pointer								xxxx xxxx	21
05h	PORTA	—	—	—	RA4	RA3	RA2	RA1	RA0	---x xxxx	23
06h	PORTB	RB7	RB6	RB5	RB4	RB3	RB2	RB1	RB0	xxxx xxxx	25
07h	PORTC <sup>(4)</sup>	RC7	RC6	RC5	RC4	RC3	RC2	RC1	RC0	xxxx xxxx	27
08h	—	Unimplemented								—	—
09h	—	Unimplemented								—	—
0Ah	PCLATH	—	—	—	Write buffer for upper 5 bits of program counter				---0 0000	21	
0Bh	INTCON	GIE	(3)	TOIE	INTE	RBIE	TOIF	INTF	RBIF	0000 000x	19
0Ch	—	Unimplemented								—	—
0Dh-1Eh	—	Unimplemented								—	—
1Fh	—	Unimplemented								—	—
<b>Bank 1</b>											
80h	INDF	Addressing this location uses contents of FSR to address data memory (not a physical register)								xxxx xxxx	21
81h	OPTION	$\overline{RBPU}$	INTEDG	T0CS	T0SE	PSA	PS2	PS1	PS0	1111 1111	18
82h	PCL	Program Counter's (PC) Least Significant Byte								0000 0000	21
83h	STATUS	—	—	RP0	$\overline{TO}$	$\overline{PD}$	Z	DC	C	0001 1xxx	17
84h	FSR	Indirect data memory address pointer								xxxx xxxx	21
85h	TRISA	—	—	—	TRISA4	TRISA3	TRISA2	TRISA1	TRISA0	---1 1111	23
86h	TRISB	TRISB7	TRISB6	TRISB5	TRISB4	TRISB3	TRISB2	TRISB1	TRISB0	1111 1111	25
87h	TRISC <sup>(4)</sup>	TRISC7	TRISC6	TRISC5	TRISC4	TRISC3	TRISC2	TRISC1	TRISC0	1111 1111	27
88h	—	Unimplemented								—	—
89h	—	Unimplemented								—	—
8Ah	PCLATH	—	—	—	Write buffer for upper 5 bits of program counter				---0 0000	21	
8Bh	INTCON	GIE	(3)	TOIE	INTE	RBIE	TOIF	INTF	RBIF	0000 000x	19
8Ch	—	Unimplemented								—	—
8Dh	—	Unimplemented								—	—
8Eh	PCON	—	—	—	—	—	—	$\overline{POR}$	—	---- --0-	20
8Fh-9Eh	—	Unimplemented								—	—
9Fh	—	Unimplemented								—	—

Legend: — = Unimplemented locations read as '0', u = unchanged, x = unknown, q = value depends on condition, shaded = unimplemented

- Note 1:** Other (non Power-up) Resets include  $\overline{MCLR}$  Reset and Watchdog Timer Reset during normal operation.  
**Note 2:** IRP & RP1 bits are reserved, always maintain these bits clear.  
**Note 3:** Bit 6 of INTCON register is reserved for future use. Always maintain this bit as clear.  
**Note 4:** PIC16C557 only.

## 4.2.2.1 STATUS Register

The STATUS register, shown in Figure 4-2, contains the arithmetic status of the ALU, the RESET status and the bank select bits for data memory.

The STATUS register can be the destination for any instruction, like any other register. If the STATUS register is the destination for an instruction that affects the Z, DC or C bits, then the write to these three bits is disabled. These bits are set or cleared according to the device logic. Furthermore, the  $\overline{TO}$  and  $\overline{PD}$  bits are not writable. Therefore, the result of an instruction with the STATUS register as the destination may be different than intended.

For example, `CLRF STATUS` will clear the upper-three bits and set the Z bit. This leaves the STATUS register as `000uu1uu` (where `u` = unchanged).

It is recommended, therefore, that only `BCF`, `BSF`, `SWAPF` and `MOVWF` instructions be used to alter the STATUS register because these instructions do not affect any status bits. For other instructions, not affecting any status bits, see the "Instruction Set Summary".

**Note 1:** The IRP and RP1 bits (STATUS<7:6>) are not used by the PIC16C55X and should be programmed as '0'. Use of these bits as general purpose R/W bits is NOT recommended, since this may affect upward compatibility with future products.

**2:** The C and DC bits operate as a Borrow and Digit Borrow out bit, respectively, in subtraction. See the `SUBLW` and `SUBWF` instructions for examples.

### REGISTER 4-1: STATUS REGISTER (ADDRESS 03h OR 83h)

Reserved	Reserved	R/W-0	R-1	R-1	R/W-x	R/W-x	R/W-x	
IRP	RP1	RP0	$\overline{TO}$	$\overline{PD}$	Z	DC	C	
bit7								bit0

bit 7 **IRP:** Register Bank Select bit (used for Indirect addressing)

1 = Bank 2, 3 (100h - 1FFh)

0 = Bank 0, 1 (00h - FFh)

The IRP bit is reserved on the PIC16C55X, always maintain this bit clear

bit 6-5 **RP1:RP0:** Register Bank Select bits (used for Direct addressing)

11 = Bank 3 (180h - 1FFh)

10 = Bank 2 (100h - 17Fh)

01 = Bank 1 (80h - FFh)

00 = Bank 0 (00h - 7Fh)

Each bank is 128 bytes. The RP1 bit is reserved on the PIC16C55X, always maintain this bit clear.

bit 4  **$\overline{TO}$ :** Timeout bit

1 = After power-up, `CLRWDT` instruction, or `SLEEP` instruction

0 = A WDT timeout occurred

bit 3  **$\overline{PD}$ :** Power-down bit

1 = After power-up or by the `CLRWDT` instruction

0 = By execution of the `SLEEP` instruction

bit 2 **Z:** Zero bit

1 = The result of an arithmetic or logic operation is zero

0 = The result of an arithmetic or logic operation is not zero

bit 1 **DC:** Digit carry/borrow bit (`ADDWF`, `ADDLW`, `SUBLW`, `SUBWF` instructions) (for borrow the polarity is reversed)

1 = A carry-out from the 4th low order bit of the result occurred

0 = No carry-out from the 4th low order bit of the result

bit 0 **C:** Carry/borrow bit (`ADDWF`, `ADDLW`, `SUBLW`, `SUBWF` instructions)

1 = A carry-out from the Most Significant bit of the result occurred

0 = No carry-out from the Most Significant bit of the result occurred

**Note 1:** For borrow the polarity is reversed. A subtraction is executed by adding the two's complement of the second operand. For rotate (`RRF`, `RLF`) instructions, this bit is loaded with either the high or low order bit of the source register.

Legend:

R = Readable bit

W = Writable bit

U = Unimplemented bit, read as '0'

- n = Value at POR reset

'1' = Bit is set

'0' = Bit is cleared

x = Bit is unknown

# PIC16C55X

## 4.2.2.2 OPTION Register

The OPTION register is a readable and writable register which contains various control bits to configure the TMR0/WDT prescaler, the external RB0/INT interrupt, TMR0 and the weak pull-ups on PORTB.

**Note 1:** To achieve a 1:1 prescaler assignment for TMR0, assign the prescaler to the WDT (PSA = 1).

### REGISTER 4-2: OPTION REGISTER (ADDRESS 81H)

	R/W-1	R/W-1	R/W-1	R/W-1	R/W-1	R/W-1	R/W-1	R/W-1
	$\overline{\text{RBPU}}$	INTEDG	T0CS	T0SE	PSA	PS2	PS1	PS0
bit7								bit0

- bit 7  **$\overline{\text{RBPU}}$** : PORTB Pull-up Enable bit  
 1 = PORTB pull-ups are disabled  
 0 = PORTB pull-ups are enabled by individual port latch values
- bit 6 **INTEDG**: Interrupt Edge Select bit  
 1 = Interrupt on rising edge of RB0/INT pin  
 0 = Interrupt on falling edge of RB0/INT pin
- bit 5 **T0CS**: TMR0 Clock Source Select bit  
 1 = Transition on RA4/T0CKI pin  
 0 = Internal instruction cycle clock (CLKOUT)
- bit 4 **T0SE**: TMR0 Source Edge Select bit  
 1 = Increment on high-to-low transition on RA4/T0CKI pin  
 0 = Increment on low-to-high transition on RA4/T0CKI pin
- bit 3 **PSA**: Prescaler Assignment bit  
 1 = Prescaler is assigned to the WDT  
 0 = Prescaler is assigned to the Timer0 module
- bit 2-0 **PS2:PS0**: Prescaler Rate Select bits

Bit Value	TMR0 Rate	WDT Rate
000	1 : 2	1 : 1
001	1 : 4	1 : 2
010	1 : 8	1 : 4
011	1 : 16	1 : 8
100	1 : 32	1 : 16
101	1 : 64	1 : 32
110	1 : 128	1 : 64
111	1 : 256	1 : 128

Legend:  
 R = Readable bit                      W = Writable bit                      U = Unimplemented bit, read as '0'  
 - n = Value at POR reset            '1' = Bit is set                      '0' = Bit is cleared                  x = Bit is unknown

## 4.2.2.3 INTCON Register

The INTCON register is a readable and writable register which contains the various enable and flag bits for all interrupt sources.

**Note:** Interrupt flag bits get set when an interrupt condition occurs regardless of the state of its corresponding enable bit or the global enable bit, GIE (INTCON<7>).

### REGISTER 4-3: INTCON REGISTER (ADDRESS 0BH OR 8BH)

	R/W-0	Reserved	R/W-0	R/W-0	R/W-0	R/W-0	R/W-0	R/W-x
	GIE	—	TOIE	INTE	RBIE	TOIF	INTF	RBIF
bit7								bit0

- bit 7     **GIE:** Global Interrupt Enable bit  
           1 = Enables all un-masked interrupts  
           0 = Disables all interrupts
- bit 6     **Reserved:** For future use. Always maintain this bit clear.
- bit 5     **TOIE:** TMR0 Overflow Interrupt Enable bit  
           1 = Enables the TMR0 interrupt  
           0 = Disables the TMR0 interrupt
- bit 4     **INTE:** RB0/INT External Interrupt Enable bit  
           1 = Enables the RB0/INT external interrupt  
           0 = Disables the RB0/INT external interrupt
- bit 3     **RBIE:** RB Port Change Interrupt Enable bit  
           1 = Enables the RB port change interrupt  
           0 = Disables the RB port change interrupt
- bit 2     **TOIF:** TMR0 Overflow Interrupt Flag bit  
           1 = TMR0 register has overflowed (must be cleared in software)  
           0 = TMR0 register did not overflow
- bit 1     **INTF:** RB0/INT External Interrupt Flag bit  
           1 = The RB0/INT external interrupt occurred (must be cleared in software)  
           0 = The RB0/INT external interrupt did not occur
- bit 0     **RBIF:** RB Port Change Interrupt Flag bit  
           1 = When at least one of the RB7:RB4 pins changed state (must be cleared in software)  
           0 = None of the RB7:RB4 pins have changed state

**Legend:**

R = Readable bit                      W = Writable bit                      U = Unimplemented bit, read as '0'  
 - n = Value at POR reset            '1' = Bit is set                      '0' = Bit is cleared                x = Bit is unknown

# PIC16C55X

## 4.2.2.4 PCON Register

The PCON register contains a flag bit to differentiate between a Power-on Reset, an external MCLR Reset or WDT Reset. See Section 6.3 and Section 6.4 for detailed RESET operation.

**REGISTER 4-4: PCON REGISTER (ADDRESS 8Eh)**

U-0	U-0	U-0	U-0	U-0	U-0	R/W-0	U-0
—	—	—	—	—	—	$\overline{\text{POR}}$	—
bit7							bit0

bit 7-2 **Unimplemented:** Read as '0'

bit 1 **POR:** Power-on Reset status bit  
1 = No Power-on Reset occurred  
0 = Power-on Reset occurred

bit 0 **Unimplemented:** Read as '0'

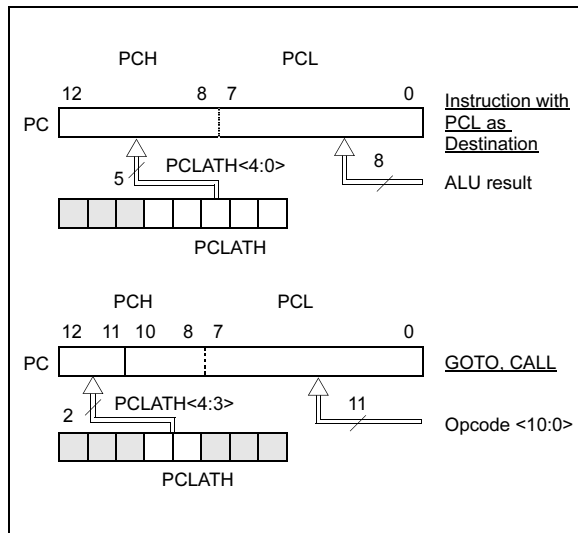
**Legend:**

R = Readable bit	W = Writable bit	U = Unimplemented bit, read as '0'
- n = Value at POR reset	'1' = Bit is set	'0' = Bit is cleared    x = Bit is unknown

## 4.3 PCL and PCLATH

The program counter (PC) is 13-bits wide. The low byte comes from the PCL register, which is a readable and writable register. The high bits (PC<12:8>) are not directly readable or writable and come from PCLATH. On any RESET, the PC is cleared. Figure 4-6 shows the two situations for the loading of the PC. The upper example in the figure shows how the PC is loaded on a write to PCL (PCLATH<4:0> → PCH). The lower example in Figure 4-6 shows how the PC is loaded during a CALL or GOTO instruction (PCLATH<4:3> → PCH).

**FIGURE 4-6: LOADING OF PC IN DIFFERENT SITUATIONS**



### 4.3.1 COMPUTED GOTO

A computed GOTO is accomplished by adding an offset to the program counter (ADDWF PCL). When doing a table read using a computed GOTO method, care should be exercised if the table location crosses a PCL memory boundary (each 256 byte block). Refer to the application note "Implementing a Table Read" (AN556).

### 4.3.2 STACK

The PIC16C55X family has an 8-level deep x 13-bit wide hardware stack (Figure 4-1 and Figure 4-2). The stack space is not part of either program or data space and the stack pointer is not readable or writable. The PC is PUSHed onto the stack when a CALL instruction is executed or an interrupt causes a branch. The stack is POPed in the event of a RETURN, RETLW or a RETFIE instruction execution. PCLATH is not affected by a PUSH or POP operation.

The stack operates as a circular buffer. This means that after the stack has been PUSHed eight times, the ninth push overwrites the value that was stored from the first push. The tenth push overwrites the second push (and so on).

**Note 1:** There are no status bits to indicate stack overflow or stack underflow conditions.

**2:** There are no instructions mnemonics called PUSH or POP. These are actions that occur from the execution of the CALL, RETURN, RETLW and RETFIE instructions, or vectoring to an interrupt address.

## 4.4 Indirect Addressing, INDF and FSR Registers

The INDF register is not a physical register. Addressing the INDF register will cause indirect addressing.

Indirect addressing is possible by using the INDF register. Any instruction using the INDF register actually accesses data pointed to by the file select register (FSR). Reading INDF itself indirectly will produce 00h. Writing to the INDF register indirectly results in a no-operation (although status bits may be affected). An effective 9-bit address is obtained by concatenating the 8-bit FSR register and the IRP bit (STATUS<7>), as shown in Figure 4-7. However, IRP is not used in the PIC16C55X.

A simple program to clear RAM locations 20h-2Fh using indirect addressing is shown in Example 4-1.

### EXAMPLE 4-1: INDIRECT ADDRESSING

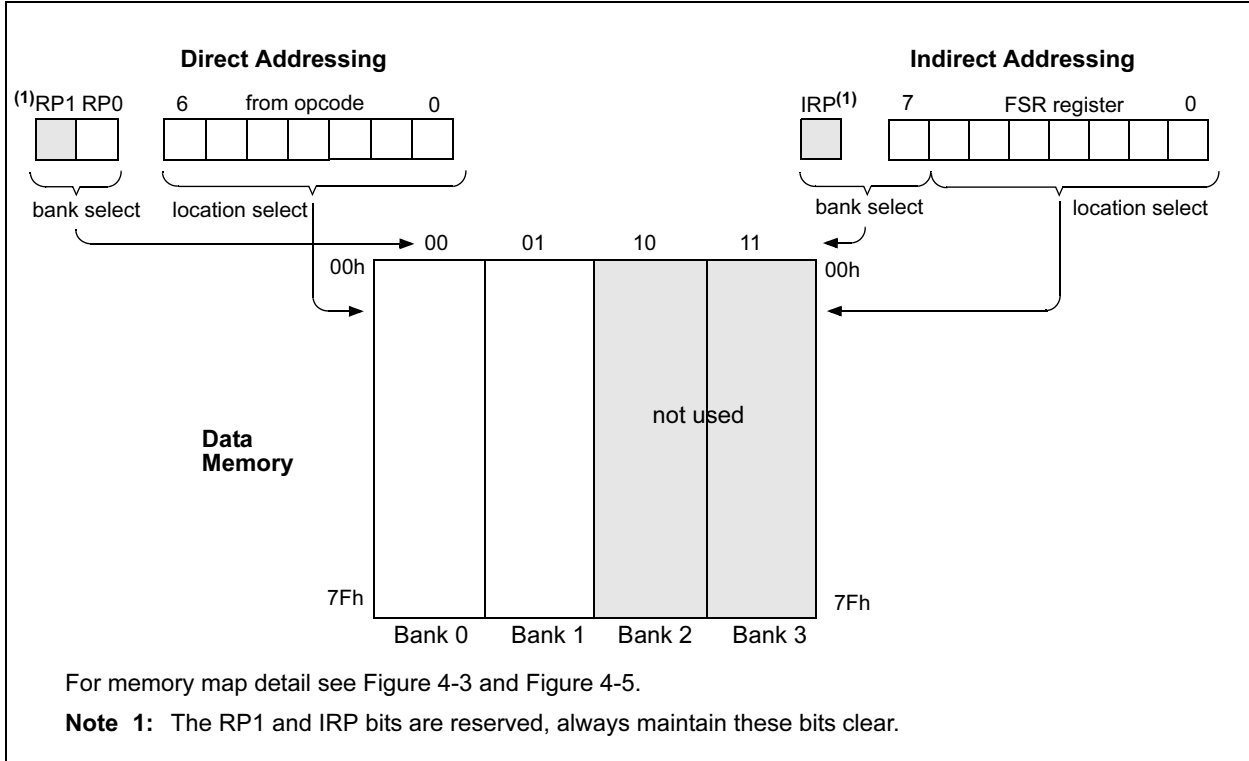
```

        movlw 0x20 ;initialize pointer
        movwf FSR ;to RAM
NEXT    clrf INDF ;clear INDF register
        incf FSR ;inc pointer
        btfss FSR,4 ;all done?
        goto NEXT ;no clear next
                ;yes continue
    
```

CONTINUE:

# PIC16C55X

**FIGURE 4-7: DIRECT/INDIRECT ADDRESSING PIC16C55X**





## 5.0 I/O PORTS

The PIC16C554 and PIC16C558 have two ports, PORTA and PORTB. The PIC16C557 has three ports, PORTA, PORTB and PORTC.

### 5.1 PORTA and TRISA Registers

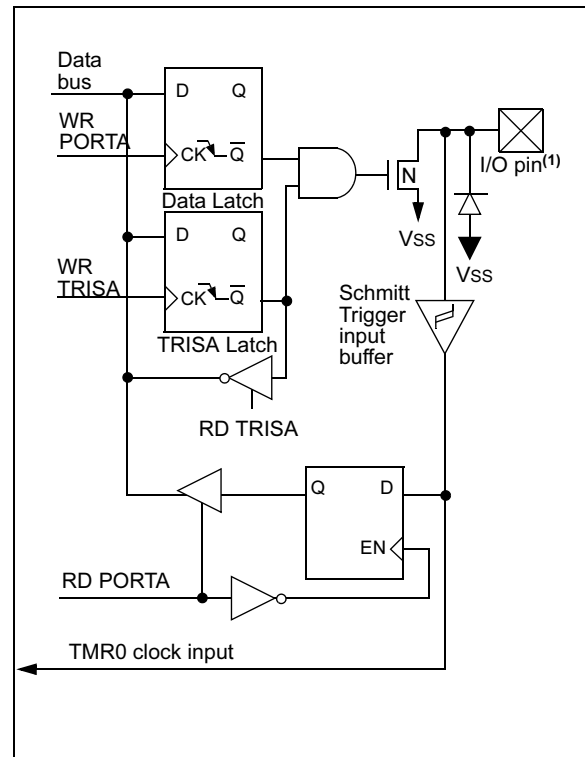
PORTA is a 5-bit wide latch. RA4 is a Schmitt Trigger input and an open-drain output. Port RA4 is multiplexed with the T0CKI clock input. All other RA port pins have Schmitt Trigger input levels and full CMOS output drivers. All pins have data direction bits (TRIS registers) which can configure these pins as input or output.

A '1' in the TRISA register puts the corresponding output driver in a Hi-impedance mode. A '0' in the TRISA register puts the contents of the output latch on the selected pin(s).

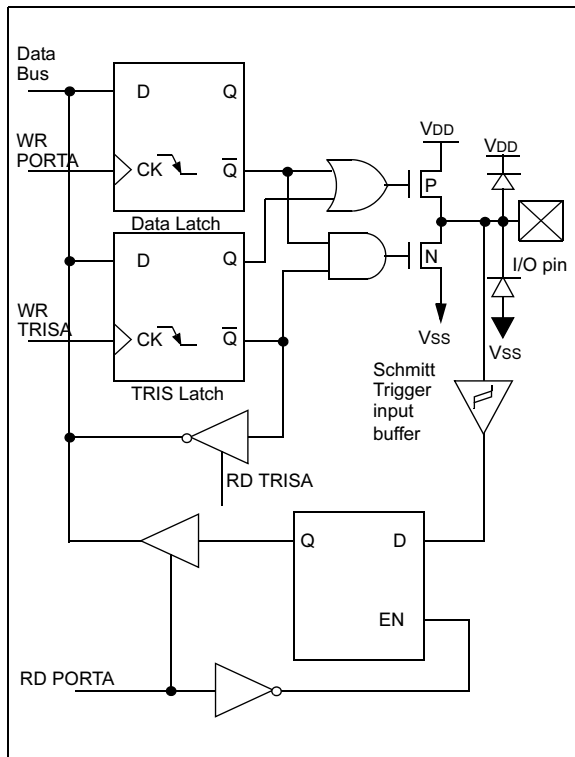
Reading the PORTA register reads the status of the pins, whereas writing to it will write to the port latch. All write operations are read-modify-write operations. So a write to a port implies that the port pins are first read, then this value is modified and written to the port data latch.

**Note 1:** On RESET, the TRISA register is set to all inputs.

**FIGURE 5-2: BLOCK DIAGRAM OF RA4 PIN**



**FIGURE 5-1: BLOCK DIAGRAM OF PORT PINS RA<3:0>**



# PIC16C55X

**TABLE 5-1: PORTA FUNCTIONS**

Name	Bit #	Buffer Type	Function
RA0	Bit 0	ST	Bi-directional I/O port.
RA1	Bit 1	ST	Bi-directional I/O port.
RA2	Bit 2	ST	Bi-directional I/O port.
RA3	Bit 3	ST	Bi-directional I/O port.
RA4/T0CKI	Bit 4	ST	Bi-directional I/O port or external clock input for TMR0. Output is open drain type.

Legend: ST = Schmitt Trigger input

**TABLE 5-2: SUMMARY OF REGISTERS ASSOCIATED WITH PORTA**

Address	Name	Bit 7	Bit 6	Bit 5	Bit 4	Bit 3	Bit 2	Bit 1	Bit 0	Value on POR	Value on All Other RESETS
05h	PORTA	—	—	—	RA4	RA3	RA2	RA1	RA0	---x xxxx	---u uuuu
85h	TRISA	—	—	—	TRISA4	TRISA3	TRISA2	TRISA1	TRISA0	---1 1111	---1 1111

Legend: — = Unimplemented locations, read as '0', x = unknown, u = unchanged

**Note 1:** Shaded bits are not used by PORTA.

## 5.2 PORTB and TRISB Registers

PORTB is an 8-bit wide bi-directional port. The corresponding data direction register is TRISB. A '1' in the TRISB register puts the corresponding output driver in a Hi-impedance mode. A '0' in the TRISB register puts the contents of the output latch on the selected pin(s).

Reading PORTB register reads the status of the pins whereas writing to it will write to the port latch. All write operations are read-modify-write operations. So a write to a port implies that the port pins are first read, then this value is modified and written to the port data latch.

Each of the PORTB pins has a weak internal pull-up ( $\approx 200 \mu\text{A}$  typical). A single control bit can turn on all the pull-ups. This is done by clearing the  $\overline{\text{RBP}}\text{U}$  (OPTION<7>) bit. The weak pull-up is automatically turned off when the port pin is configured as an output. The pull-ups are disabled on Power-on Reset.

Four of PORTB's pins, RB7:RB4, have an interrupt-on-change feature. Only pins configured as inputs can cause this interrupt to occur (i.e., any RB7:RB4 pin configured as an output is excluded from the interrupt-on-change comparison). The input pins (of RB7:RB4) are compared with the old value latched on the last read of PORTB. The "mismatch" outputs of RB7:RB4 are OR'ed together to generate the RBIF interrupt (flag

latched in INTCON<0>). This interrupt can wake the device from SLEEP. The user, in the interrupt service routine, can clear the interrupt in the following manner:

- Any read or write of PORTB (this will end the mismatch condition)
- Clear flag bit RBIF

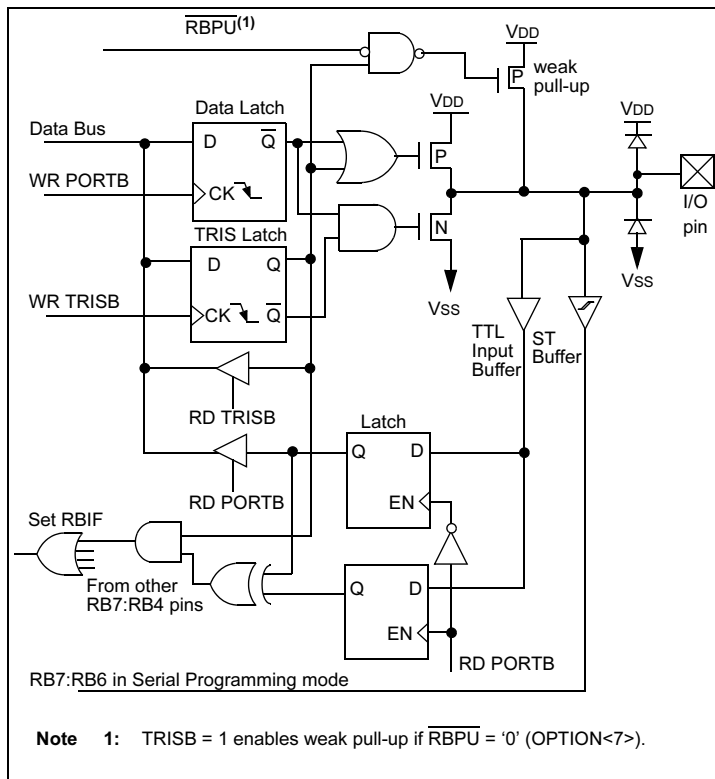
A mismatch condition will continue to set flag bit RBIF. Reading PORTB will end the mismatch condition, and allow flag bit RBIF to be cleared.

The interrupt on mismatch feature, together with software configurable pull-ups on these four pins, allows easy interface to a key pad and make it possible for wake-up on key-depression. (See AN552 in the *Microchip Embedded Control Handbook*.)

**Note 1:** If a change on the I/O pin should occur when the read operation is being executed (start of the Q2 cycle), then the RBIF interrupt flag may not get set.

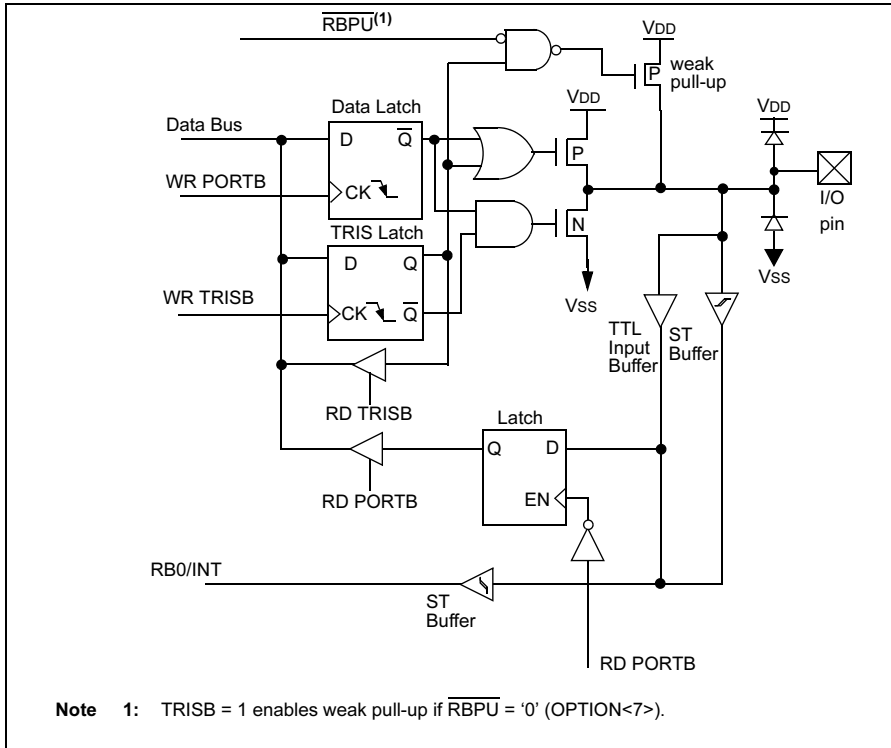
The interrupt-on-change feature is recommended for wake-up on key depression operation and operations where PORTB is only used for the interrupt-on-change feature. Polling of PORTB is not recommended while using the interrupt-on-change feature.

**FIGURE 5-3: BLOCK DIAGRAM OF RB7:RB4 PINS**



# PIC16C55X

**FIGURE 5-4: BLOCK DIAGRAM OF RB3:RB0 PINS**



**TABLE 5-3: PORTB FUNCTIONS**

Name	Bit #	Buffer Type	Function
RB0/INT	Bit 0	TTL/ST <sup>(1)</sup>	Bi-directional I/O port. Internal software programmable weak pull-up.
RB1	Bit 1	TTL	Bi-directional I/O port. Internal software programmable weak pull-up.
RB2	Bit 2	TTL	Bi-directional I/O port. Internal software programmable weak pull-up.
RB3	Bit 3	TTL	Bi-directional I/O port. Internal software programmable weak pull-up.
RB4	Bit 4	TTL	Bi-directional I/O port (with interrupt-on-change). Internal software programmable weak pull-up.
RB5	Bit 5	TTL	Bi-directional I/O port (with interrupt-on-change). Internal software programmable weak pull-up.
RB6	Bit 6	TTL/ST <sup>(2)</sup>	Bi-directional I/O port (with interrupt-on-change). Internal software programmable weak pull-up. Serial programming clock pin.
RB7	Bit 7	TTL/ST <sup>(2)</sup>	Bi-directional I/O port (with interrupt-on-change). Internal software programmable weak pull-up. Serial programming data pin.

Legend: ST = Schmitt Trigger, TTL = TTL input

**Note 1:** This buffer is a Schmitt Trigger input when configured as the external interrupt.

**Note 2:** This buffer is a Schmitt Trigger input when used in Serial Programming mode.

**TABLE 5-4: SUMMARY OF REGISTERS ASSOCIATED WITH PORTB AND TRISB**

Address	Name	Bit 7	Bit 6	Bit 5	Bit 4	Bit 3	Bit 2	Bit 1	Bit 0	Value on POR	Value on All Other RESETS
06h	PORTB	RB7	RB6	RB5	RB4	RB3	RB2	RB1	RB0	xxxx xxxx	uuuu uuuu
86h	TRISB	TRISB7	TRISB6	TRISB5	TRISB4	TRISB3	TRISB2	TRISB1	TRISB0	1111 1111	1111 1111
81h	OPTION	$\overline{\text{RBPU}}$	INTEDG	T0CS	T0SE	PSA	PS2	PS1	PS0	1111 1111	1111 1111
0BH, 8BH	INTCON	GIE	Reserved	T0IE	INTE	BRIE	T0IF	INTF	RBIF	0000 000x	0000 000x

Legend: x = unknown, u = unchanged

**Note 1:** Shaded bits are not used by PORTB.



# PIC16C55X

---

## 5.4 I/O Programming Considerations

### 5.4.1 BI-DIRECTIONAL I/O PORTS

Any instruction which writes, operates internally as a read followed by a write operation. The `BCF` and `BSF` instructions, for example, read the register into the CPU, execute the bit operation and write the result back to the register. Caution must be used when these instructions are applied to a port with both inputs and outputs defined. For example, a `BSF` operation on bit5 of `PORTB` will cause all eight bits of `PORTB` to be read into the CPU. Then the `BSF` operation takes place on bit5 and `PORTB` is written to the output latches. If another bit of `PORTB` is used as a bi-directional I/O pin (e.g., bit 0) and it is defined as an input at this time, the input signal present on the pin itself would be read into the CPU and re-written to the data latch of this particular pin, overwriting the previous content. As long as the pin stays in the Input mode, no problem occurs. However, if bit 0 is switched into Output mode later on, the content of the data latch may now be unknown.

Reading the port register, reads the values of the port pins. Writing to the port register writes the value to the port latch. When using read-modify-write instructions (ex. `BCF`, `BSF`, etc.) on a port, the value of the port pins is read, the desired operation is done to this value, and this value is then written to the port latch.

Example 5-1 shows the effect of two sequential read-modify-write instructions (ex., `BCF`, `BSF`, etc.) on an I/O port

A pin actively outputting a low or high should not be driven from external devices at the same time in order to change the level on this pin ("wired-or", "wired-and"). The resulting high output currents may damage the chip.

## EXAMPLE 5-1: READ-MODIFY-WRITE INSTRUCTIONS ON AN I/O PORT

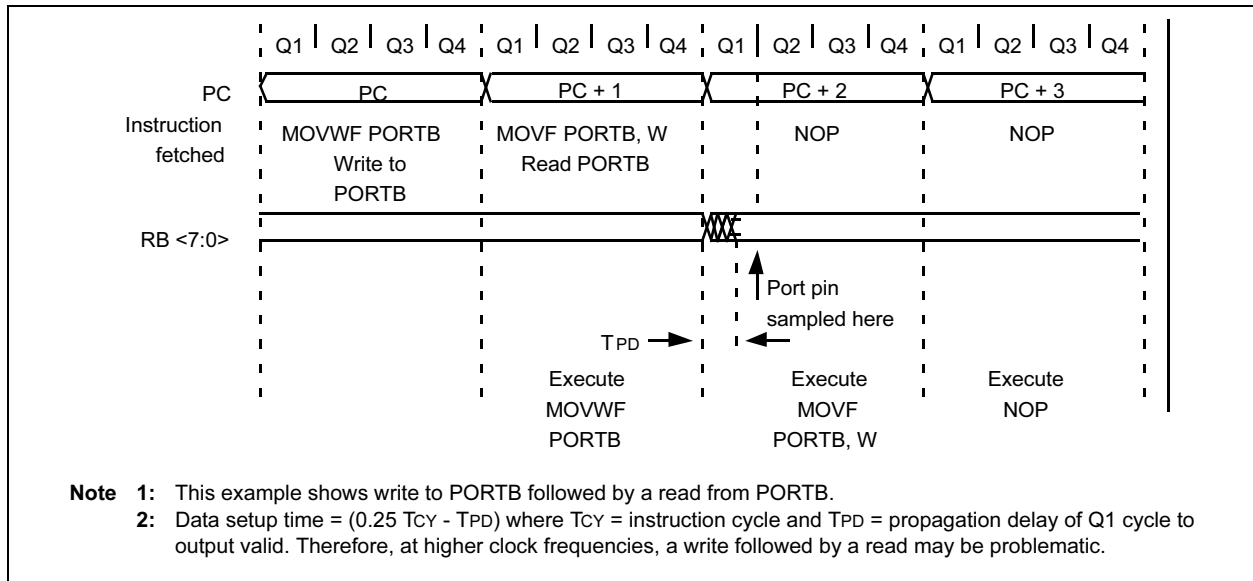
```

; Initial PORT settings: PORTB<7:4> Inputs
;
;                               PORTB<3:0> Outputs
; PORTB<7:6> have external pull-up and are
; not connected to other circuitry
;
;                               PORT latch PORT pins
;                               -----
;
BCF PORTB, 7    ; 01pp pppp 11pp pppp
BCF PORTB, 6    ; 10pp pppp 11pp pppp
BSF STATUS, RP0 ;
BCF TRISB, 7    ; 10pp pppp 11pp pppp
BCF TRISB, 6    ; 10pp pppp 10pp pppp
    
```

## 5.4.2 SUCCESSIVE OPERATIONS ON I/O PORTS

The actual write to an I/O port happens at the end of an instruction cycle, whereas for reading, the data must be valid at the beginning of the instruction cycle, as shown in Figure 5-6. Therefore, care must be exercised if a write followed by a read operation is carried out on the same I/O port. The sequence of instructions should be such to allow the pin voltage to stabilize (load dependent) before the next instruction which causes that file to be read into the CPU is executed. Otherwise, the previous state of that pin may be read into the CPU rather than the new state. When in doubt, it is better to separate these instructions with an NOP or another instruction not accessing this I/O port.

**FIGURE 5-6: SUCCESSIVE I/O OPERATION**



- Note 1:** This example shows write to PORTB followed by a read from PORTB.
- Note 2:** Data setup time =  $(0.25 T_{CY} - T_{PD})$  where  $T_{CY}$  = instruction cycle and  $T_{PD}$  = propagation delay of Q1 cycle to output valid. Therefore, at higher clock frequencies, a write followed by a read may be problematic.

# PIC16C55X

---

NOTES:



## 6.0 SPECIAL FEATURES OF THE CPU

What sets a microcontroller apart from other processors are special circuits to deal with the needs of real-time applications. The PIC16C55X family has a host of such features intended to maximize system reliability, minimize cost through elimination of external components, provide power saving operating modes and offer code protection.

These are:

1. OSC selection
2. RESET
3. Power-on Reset (POR)
4. Power-up Timer (PWRT)
5. Oscillator Start-Up Timer (OST)
6. Interrupts
7. Watchdog Timer (WDT)
8. SLEEP
9. Code protection
10. ID Locations
11. In-circuit serial programming™

The PIC16C55X has a Watchdog Timer which is controlled by configuration bits. It runs off its own RC oscillator for added reliability. There are two timers that offer necessary delays on power-up. One is the Oscillator Start-up Timer (OST), which is intended to keep the chip in RESET until the crystal oscillator is stable. The other is the Power-up Timer (PWRT), which provides a fixed delay of 72 ms (nominal) on power-up only, designed to keep the part in RESET while the power supply stabilizes. With these two functions on-chip, most applications need no external RESET circuitry.

The SLEEP mode is designed to offer a very low current Power-down mode. The user can wake-up from SLEEP through external RESET, Watchdog Timer wake-up or through an interrupt. Several oscillator options are also made available to allow the part to fit the application. The RC oscillator option saves system cost while the LP crystal option saves power. A set of configuration bits are used to select various options.

## 6.1 Configuration Bits

The configuration bits can be programmed (read as '0') or left unprogrammed (read as '1') to select various device configurations. These bits are mapped in program memory location 2007h.

The user will note that address 2007h is beyond the user program memory space. In fact, it belongs to the special test/configuration memory space (2000h – 3FFFh), which can be accessed only during programming.

# PIC16C55X

## REGISTER 6-1: CONFIGURATION WORD

CP1	CP0	CP1	CP0	CP1	CP0	—	Reserved	CP1	CP0	PWRTE	WDTE	FOSC1	FOSC0
bit 13													bit 0

bit 13-8 **CP<1:0>**: Code protection bits<sup>(1)</sup>  
 bit 5-4 11 = Program Memory code protection off  
 10 = 0400h - 07FFh code protected  
 01 = 0200h - 07FFh code protected  
 00 = 0000h - 07FFh code protected

bit 7 **Unimplemented**: Read as '1'

bit 6 **Reserved**: Do not use

bit 3 **PWRTE**: Power-up Timer Enable bit  
 1 = PWRT disabled  
 0 = PWRT enabled

bit 2 **WDTE**: Watchdog Timer Enable bit  
 1 = WDT enabled  
 0 = WDT disabled

bit 1-0 **FOSC1:FOSC0**: Oscillator Selection bits  
 11 = RC oscillator  
 10 = HS oscillator  
 01 = XT oscillator  
 00 = LP oscillator

**Note 1:** All of the CP1:CP0 pairs have to be given the same value to enable the code protection scheme listed.

Legend:			
R = Readable bit	W = Writable bit	U = Unimplemented bit, read as '0'	
- n = Value at POR reset	'1' = Bit is set	'0' = Bit is cleared	x = Bit is unknown

## 6.2 Oscillator Configurations

### 6.2.1 OSCILLATOR TYPES

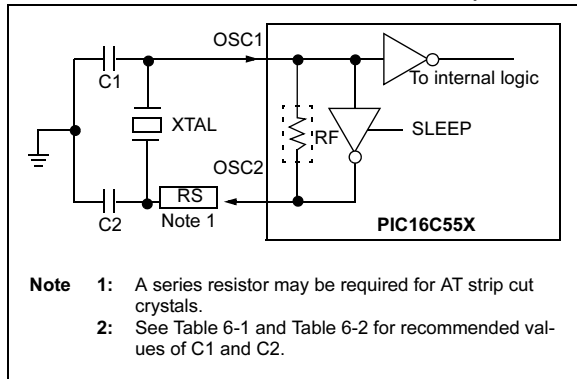
The PIC16C55X can be operated in four different oscillator options. The user can program two configuration bits (FOSC1 and FOSC0) to select one of these four modes:

- LP Low Power Crystal
- XT Crystal/Resonator
- HS High Speed Crystal/Resonator
- RC Resistor/Capacitor

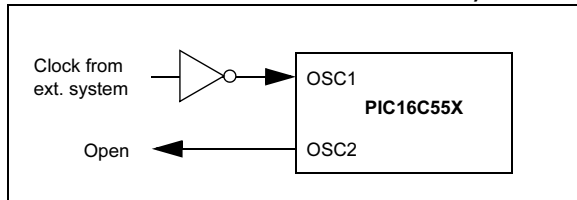
### 6.2.2 CRYSTAL OSCILLATOR / CERAMIC RESONATORS

In XT, LP or HS modes a crystal or ceramic resonator is connected to the OSC1 and OSC2 pins to establish oscillation (Figure 6-1). The PIC16C55X oscillator design requires the use of a parallel cut crystal. Use of a series cut crystal may give a frequency out of the crystal manufacturers specifications. When in XT, LP or HS modes, the device can have an external clock source to drive the OSC1 pin (Figure 6-2).

**FIGURE 6-1: CRYSTAL OPERATION (OR CERAMIC RESONATOR) (HS, XT OR LP OSC CONFIGURATION)**



**FIGURE 6-2: EXTERNAL CLOCK INPUT OPERATION (HS, XT OR LP OSC CONFIGURATION)**



**TABLE 6-1: CAPACITOR SELECTION FOR CERAMIC RESONATORS (PRELIMINARY)**

Ranges Characterized:			
Mode	Freq	OSC1(C1)	OSC2(C2)
XT	455 kHz	22 - 100 pF	22 - 100 pF
	2.0 MHz	15 - 68 pF	15 - 68 pF
	4.0 MHz	15 - 68 pF	15 - 68 pF
HS	8.0 MHz	10 - 68 pF	10 - 68 pF
	16.0 MHz	10 - 22 pF	10 - 22 pF

**Note 1:** Higher capacitance increases the stability of the oscillator but also increases the start-up time. These values are for design guidance only. Since each resonator has its own characteristics, the user should consult with the resonator manufacturer for appropriate values of external components.

**TABLE 6-2: CAPACITOR SELECTION FOR CRYSTAL OSCILLATOR (PRELIMINARY)**

Mode	Freq	OSC1(C1)	OSC2(C2)
LP	32 kHz	68 - 100 pF	68 - 100 pF
	200 kHz	15 - 30 pF	15 - 30 pF
XT	100 kHz	68 - 150 pF	150 - 200 pF
	2 MHz	15 - 30 pF	15 - 30 pF
	4 MHz	15 - 30 pF	15 - 30 pF
HS	8 MHz	15 - 30 pF	15 - 30 pF
	10 MHz	15 - 30 pF	15 - 30 pF
	20 MHz	15 - 30 pF	15 - 30 pF

**Note 1:** Higher capacitance increases the stability of the oscillator but also increases the start-up time. These values are for design guidance only. Rs may be required in HS mode as well as XT mode to avoid over-driving crystals with low-drive level specification. Since each crystal has its own characteristics, the user should consult with the crystal manufacturer for appropriate values of external components.

# PIC16C55X

## 6.2.3 EXTERNAL CRYSTAL OSCILLATOR CIRCUIT

Either a pre-packaged oscillator can be used or a simple oscillator circuit with TTL gates can be built. Prepackaged oscillators provide a wide operating range and better stability. A well-designed crystal oscillator will provide good performance with TTL gates. Two types of crystal oscillator circuits can be used: one with series resonance, or one with parallel resonance.

Figure 6-3 shows implementation of a parallel resonant oscillator circuit. The circuit is designed to use the fundamental frequency of the crystal. The 74AS04 inverter performs the 180° phase shift that a parallel oscillator requires. The 4.7 kΩ resistor provides the negative feedback for stability. The 10 kΩ potentiometers bias the 74AS04 in the linear region. This could be used for external oscillator designs.

**FIGURE 6-3: EXTERNAL PARALLEL RESONANT CRYSTAL OSCILLATOR CIRCUIT**

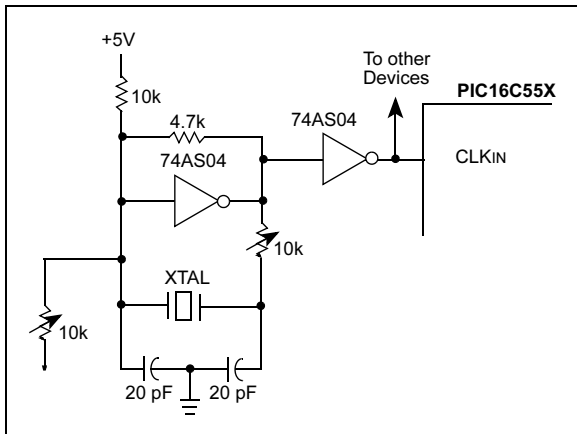
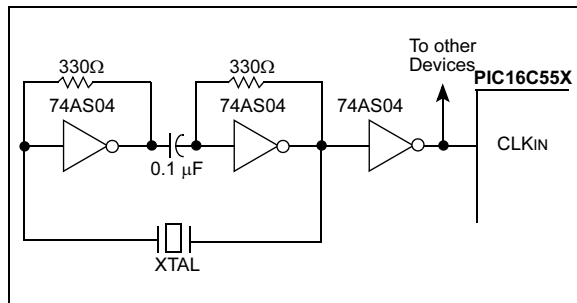


Figure 6-4 shows a series resonant oscillator circuit. This circuit is also designed to use the fundamental frequency of the crystal. The inverter performs a 180° phase shift in a series resonant oscillator circuit. The 330Ω resistors provide the negative feedback to bias the inverters in their linear region.

**FIGURE 6-4: EXTERNAL SERIES RESONANT CRYSTAL OSCILLATOR CIRCUIT**



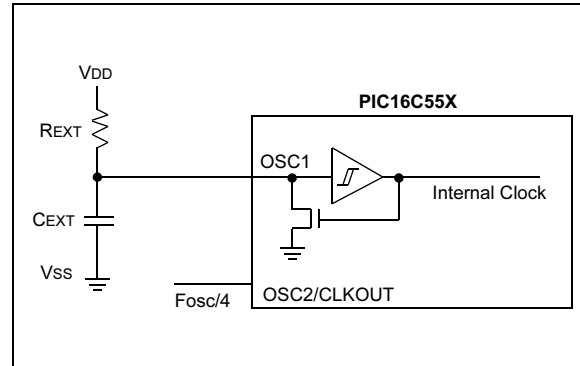
## 6.2.4 RC OSCILLATOR

For timing insensitive applications the “RC” device option offers additional cost savings. The RC oscillator frequency is a function of the supply voltage, the resistor ( $R_{EXT}$ ) and capacitor ( $C_{EXT}$ ) values, and the operating temperature. In addition to this, the oscillator frequency will vary from unit to unit due to normal process parameter variation. Furthermore, the difference in lead frame capacitance between package types will also affect the oscillation frequency, especially for low  $C_{EXT}$  values. The user also needs to take into account variation due to tolerance of external R and C components used. Figure 6-5 shows how the R/C combination is connected to the PIC16C55X. For  $R_{EXT}$  values below 2.2 kΩ, the oscillator operation may become unstable, or stop completely. For very high  $R_{EXT}$  values (e.g., 1 MΩ), the oscillator becomes sensitive to noise, humidity and leakage. Thus, we recommend to keep  $R_{EXT}$  between 3 kΩ and 100 kΩ.

Although the oscillator will operate with no external capacitor ( $C_{EXT} = 0$  pF), we recommend using values above 20 pF for noise and stability reasons. With no or small external capacitance, the oscillation frequency can vary dramatically due to changes in external capacitances, such as PCB trace capacitance or package lead frame capacitance.

The oscillator frequency, divided by 4, is available on the OSC2/CLKOUT pin, and can be used for test purposes or to synchronize other logic (Figure 3-2 for waveform).

**FIGURE 6-5: RC OSCILLATOR MODE**



## 6.3 RESET

The PIC16C55X differentiates between various kinds of RESET:

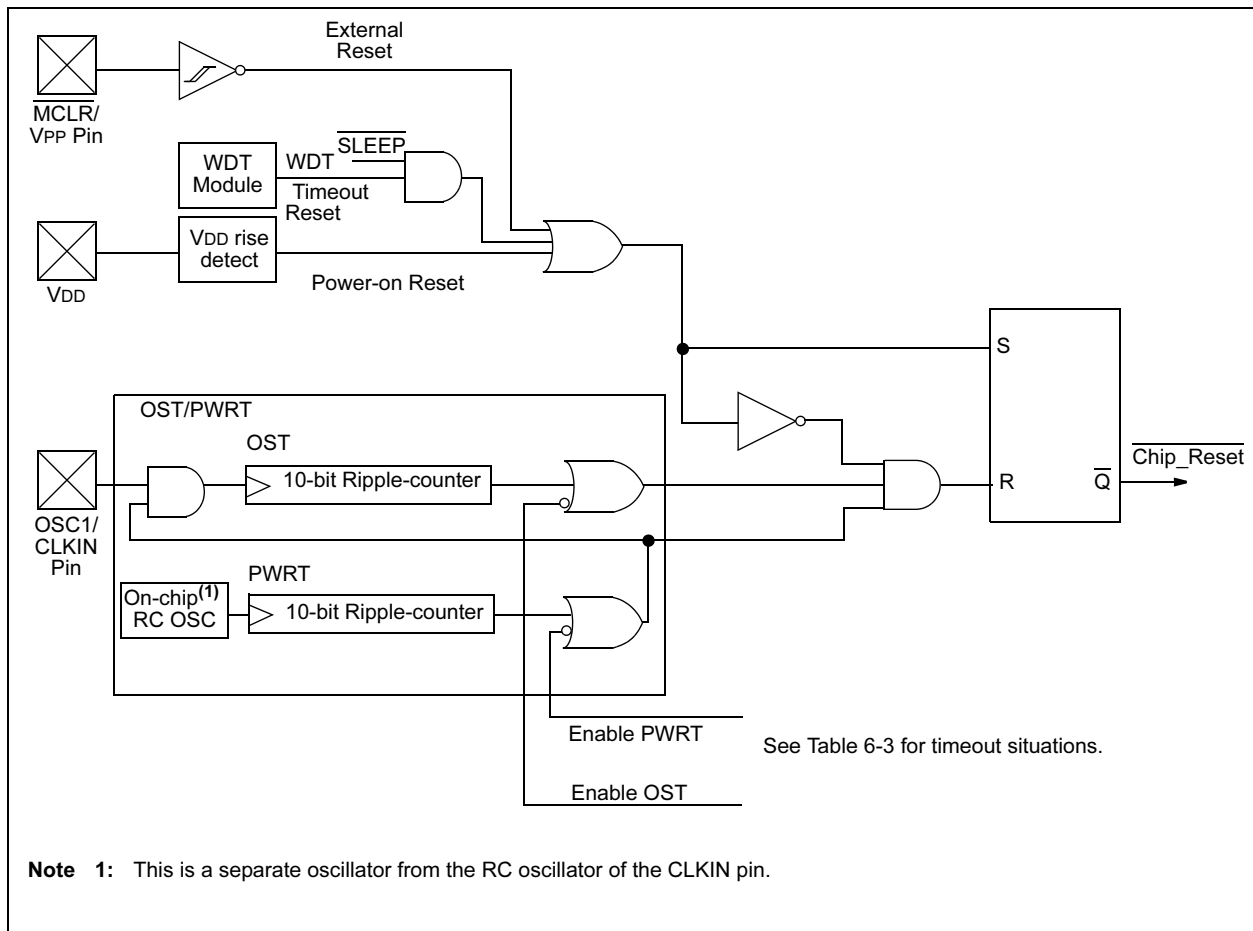
- Power-on Reset (POR)
- $\overline{\text{MCLR}}$  Reset during normal operation
- $\overline{\text{MCLR}}$  Reset during SLEEP
- WDT Reset (normal operation)
- WDT wake-up (SLEEP)

Some registers are not affected in any RESET condition; their status is unknown on POR and unchanged in any other RESET. Most other registers are reset to a "RESET state" on Power-on Reset, on  $\overline{\text{MCLR}}$  or WDT Reset and on  $\overline{\text{MCLR}}$  Reset during SLEEP. They are not affected by a WDT wake-up, since this is viewed as the resumption of normal operation.  $\overline{\text{TO}}$  and  $\overline{\text{PD}}$  bits are set or cleared differently in different RESET situations as indicated in Table 6-4. These bits are used in software to determine the nature of the RESET. See Table 6-6 for a full description of RESET states of all registers.

A simplified block diagram of the on-chip RESET circuit is shown in Figure 6-6.

The  $\overline{\text{MCLR}}$  Reset path has a noise filter to detect and ignore small pulses. See Table 10-3 for pulse width specification.

**FIGURE 6-6: SIMPLIFIED BLOCK DIAGRAM OF ON-CHIP RESET CIRCUIT**



## 6.4 Power-on Reset (POR), Power-up Timer (PWRT), Oscillator Start-up Timer (OST)

### 6.4.1 POWER-ON RESET (POR)

A Power-on Reset pulse is generated on-chip when VDD rise is detected (in the range of 1.6V – 1.8V). To take advantage of the POR, just tie the  $\overline{\text{MCLR}}$  pin through a resistor to VDD. This will eliminate external RC components usually needed to create Power-on Reset. A maximum rise time for VDD is required. See Electrical Specifications for details.

The POR circuit does not produce internal RESET when VDD declines.

When the device starts normal operation (exits the RESET condition), device operating parameters (voltage, frequency, temperature, etc.) must be met to ensure operation. If these conditions are not met, the device must be held in RESET until the operating conditions are met.

For additional information, refer to Application Note AN607 “Power-up Trouble Shooting”.

### 6.4.2 POWER-UP TIMER (PWRT)

The Power-up Timer provides a fixed 72 ms (nominal) timeout on power-up only, from POR. The Power-up Timer operates on an internal RC oscillator. The chip is kept in RESET as long as PWRT is active. The PWRT delay allows the VDD to rise to an acceptable level. A configuration bit,  $\overline{\text{PWRTE}}$  can disable (if set) or enable (if cleared or programmed) the Power-up Timer. The Power-Up Time delay will vary from chip to chip and due to VDD, temperature and process variation. See DC parameters for details.

### 6.4.3 OSCILLATOR START-UP TIMER (OST)

The Oscillator Start-Up Timer (OST) provides a 1024 oscillator cycle (from OSC1 input) delay after the PWRT delay is over. This ensures that the crystal oscillator or resonator has started and stabilized.

The OST timeout is invoked only for XT, LP and HS modes and only on Power-on Reset or wake-up from SLEEP.

### 6.4.4 TIMEOUT SEQUENCE

On power-up, the timeout sequence is as follows: First PWRT timeout is invoked after POR has expired, then OST is activated. The total timeout will vary based on oscillator configuration and  $\overline{\text{PWRTE}}$  bit status. For example, in RC mode with  $\overline{\text{PWRTE}}$  bit erased (PWRT disabled), there will be no timeout at all. Figure 6-7, Figure 6-8 and Figure 6-9 depict timeout sequences.

Since the timeouts occur from the POR pulse, if  $\overline{\text{MCLR}}$  is kept low long enough, the timeouts will expire. Then bringing  $\overline{\text{MCLR}}$  high will begin execution immediately (see Figure 6-8). This is useful for testing purposes or to synchronize more than one PIC16C55X device operating in parallel.

Table 6-5 shows the RESET conditions for some special registers, while Table 6-6 shows the RESET conditions for all the registers.

## 6.4.5 POWER CONTROL/STATUS REGISTER (PCON)

Bit1 is  $\overline{\text{POR}}$  (Power-on Reset). It is a '0' on Power-on Reset and unaffected otherwise. The user must write a '1' to this bit following a Power-on Reset. On a subsequent RESET if  $\overline{\text{POR}}$  is '0', it will indicate that a Power-on Reset must have occurred ( $V_{DD}$  may have gone too low).

**TABLE 6-3: TIMEOUT IN VARIOUS SITUATIONS**

Oscillator Configuration	Power-up		Wake-up from SLEEP
	$\overline{\text{PWRT}} = 0$	$\overline{\text{PWRT}} = 1$	
XT, HS, LP	72 ms + 1024 T <sub>osc</sub>	1024 T <sub>osc</sub>	1024 T <sub>osc</sub>
RC	72 ms	—	—

**TABLE 6-4: STATUS BITS AND THEIR SIGNIFICANCE**

POR	TO	PD	
0	1	1	Power-on Reset
0	0	x	Illegal, $\overline{\text{TO}}$ is set on $\overline{\text{POR}}$
0	x	0	Illegal, $\overline{\text{PD}}$ is set on $\overline{\text{POR}}$
1	0	u	WDT Reset
1	0	0	WDT Wake-up
1	u	u	$\overline{\text{MCLR}}$ Reset during normal operation
1	1	0	$\overline{\text{MCLR}}$ Reset during SLEEP

# PIC16C55X

**TABLE 6-5: INITIALIZATION CONDITION FOR SPECIAL REGISTERS**

Condition	Program Counter	STATUS Register	PCON Register
Power-on Reset	000h	0001 1xxx	---- --0-
MCLR Reset during normal operation	000h	000u uuuu	---- --u-
MCLR Reset during SLEEP	000h	0001 0uuu	---- --u-
WDT Reset	000h	0000 uuuu	---- --u-
WDT Wake-up	PC + 1	uuu0 0uuu	---- --u-
Interrupt Wake-up from SLEEP	PC + 1 <sup>(1)</sup>	uuu1 0uuu	---- --u-

Legend: u = unchanged, x = unknown, - = unimplemented bit, reads as '0', q = value depends on condition.

**Note 1:** When the wake-up is due to an interrupt and global enable bit, GIE is set, the PC is loaded with the interrupt vector (0004h) after execution of PC+1.

**TABLE 6-6: INITIALIZATION CONDITION FOR REGISTERS**

Register	Address	Power-on Reset	MCLR Reset during normal operation MCLR Reset during SLEEP WDT Reset	Wake-up from SLEEP through interrupt Wake-up from SLEEP through WDT timeout
W	—	xxxx xxxx	uuuu uuuu	uuuu uuuu
INDF	00h	—	—	—
TMR0	01h	xxxx xxxx	uuuu uuuu	uuuu uuuu
PCL	02h	0000 0000	0000 0000	PC + 1 <sup>(2)</sup>
STATUS	03h	0001 1xxx	000q quuu <sup>(3)</sup>	uuuq quuu <sup>(3)</sup>
FSR	04h	xxxx xxxx	uuuu uuuu	uuuu uuuu
PORTA	05h	---x xxxx	---u uuuu	---u uuuu
PORTB	06h	xxxx xxxx	uuuu uuuu	uuuu uuuu
PORTC <sup>(4)</sup>	06h	xxxx xxxx	uuuu uuuu	uuuu uuuu
PCLATH	0Ah	---0 0000	---0 0000	---u uuuu
INTCON	0Bh	0000 000x	0000 000u	uuuu uuuu <sup>(1)</sup>
OPTION	81h	1111 1111	1111 1111	uuuu uuuu
TRISA	85h	---1 1111	---1 1111	---u uuuu
TRISB	86h	1111 1111	1111 1111	uuuu uuuu
TRISC <sup>(4)</sup>	86h	1111 1111	1111 1111	uuuu uuuu
PCON	8Eh	---- --0-	---- --u-	---- --u-

Legend: u = unchanged, x = unknown, - = unimplemented bit, reads as '0', q = value depends on condition.

**Note 1:** One or more bits in INTCON will be affected (to cause wake-up).

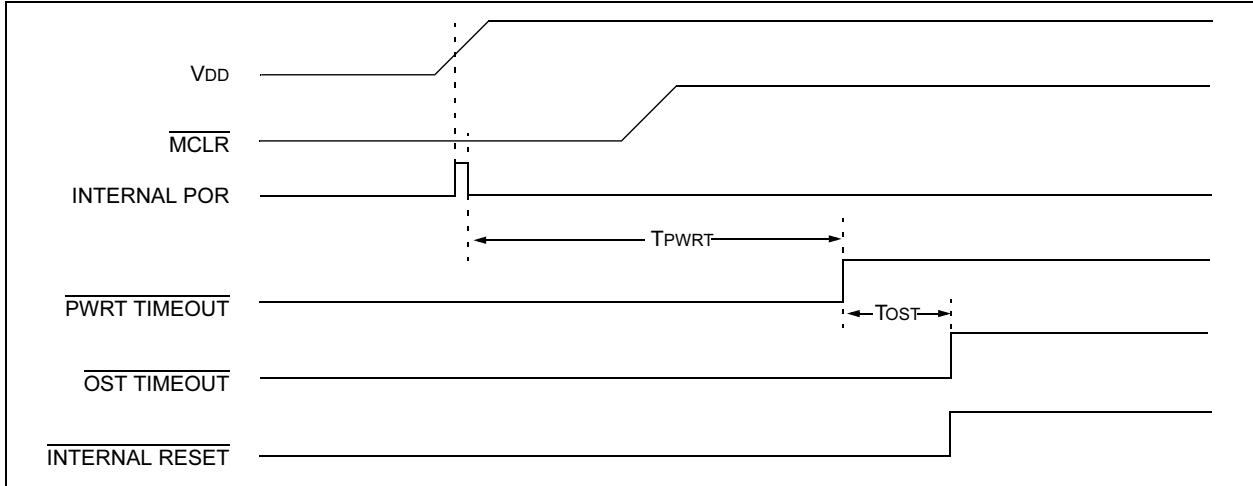
**2:** When the wake-up is due to an interrupt and the GIE bit is set, the PC is loaded with the interrupt vector (0004h).

**3:** See Table 6-5 for RESET value for specific condition.

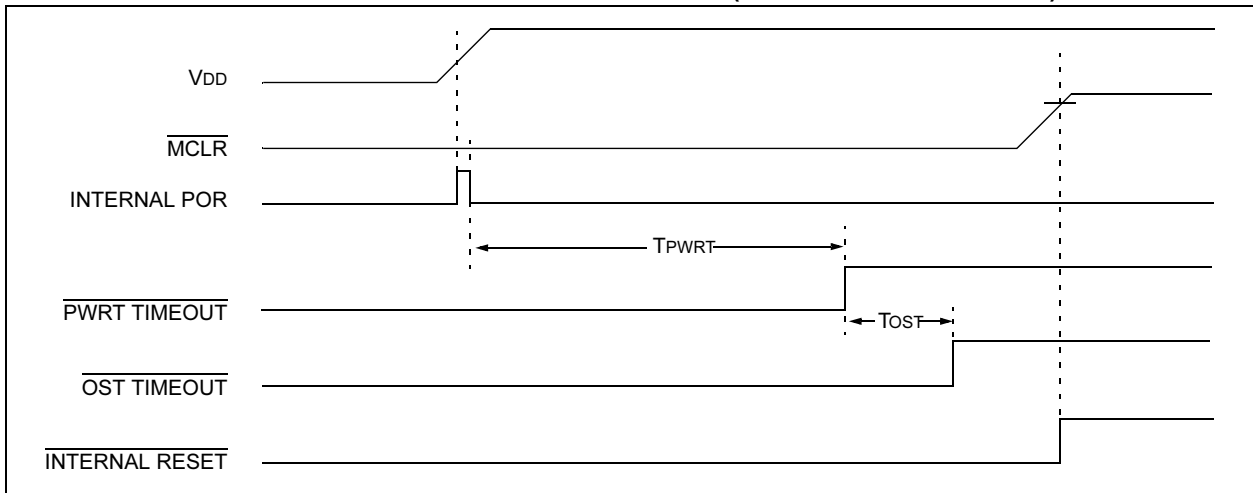
**4:** PIC16C557 only.



**FIGURE 6-7: TIMEOUT SEQUENCE ON POWER-UP ( $\overline{\text{MCLR}}$  NOT TIED TO  $V_{\text{DD}}$ ): CASE 1**

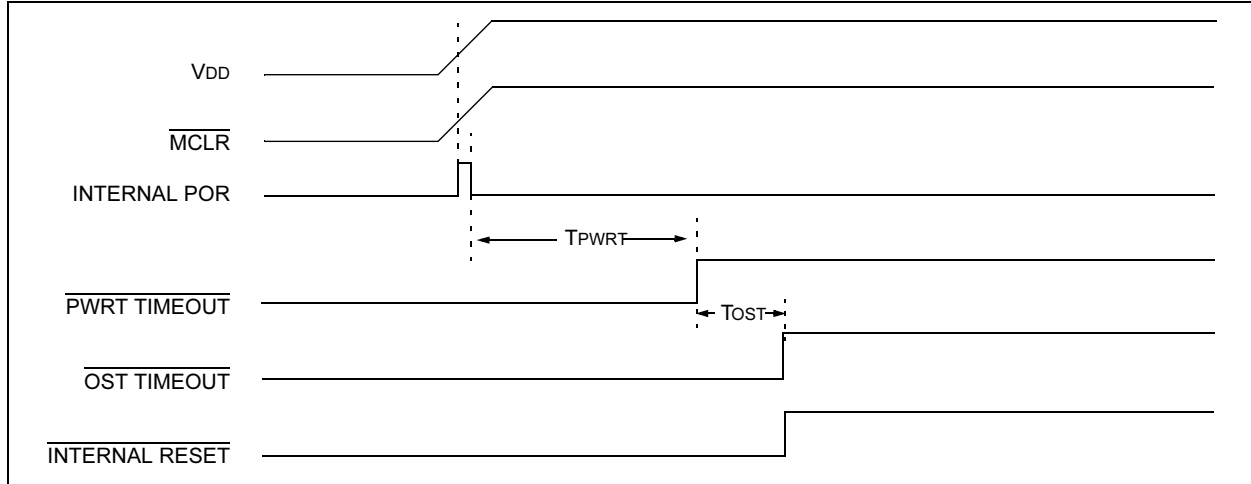


**FIGURE 6-8: TIMEOUT SEQUENCE ON POWER-UP ( $\overline{\text{MCLR}}$  NOT TIED TO  $V_{\text{DD}}$ ): CASE 2**

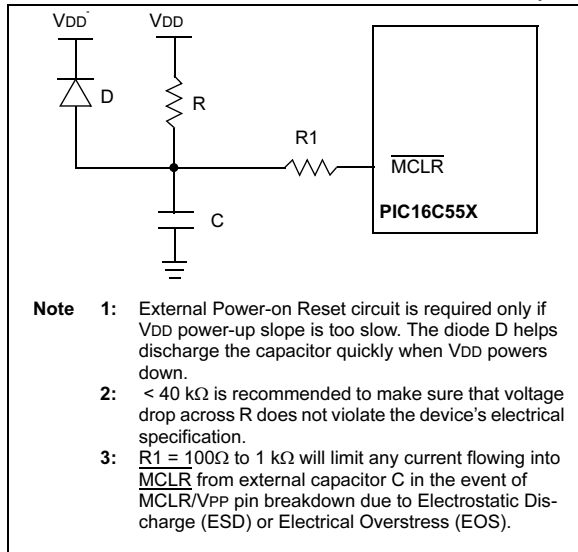


# PIC16C55X

**FIGURE 6-9: TIMEOUT SEQUENCE ON POWER-UP ( $\overline{\text{MCLR}}$  TIED TO  $V_{DD}$ ): CASE 3**



**FIGURE 6-10: EXTERNAL POWER-ON RESET CIRCUIT (FOR SLOW  $V_{DD}$  POWER-UP)**



## 6.5 Interrupts

The PIC16C55X has 3 sources of interrupt:

- External interrupt RB0/INT
- TMR0 overflow interrupt
- PORTB change interrupts (pins RB7:RB4)

The interrupt control register (INTCON) records individual interrupt requests in flag bits. It also has individual and global interrupt enable bits.

A global interrupt enable bit, GIE (INTCON<7>) enables (if set) all un-masked interrupts or disables (if cleared) all interrupts. Individual interrupts can be disabled through their corresponding enable bits in INTCON register. GIE is cleared on RESET.

The “Return from Interrupt” instruction, RETFIE, exits the interrupt routine as well as sets the GIE bit, which re-enables RB0/INT interrupts.

The INT pin interrupt, the RB port change interrupt and the TMR0 overflow interrupt flags are contained in the INTCON register.

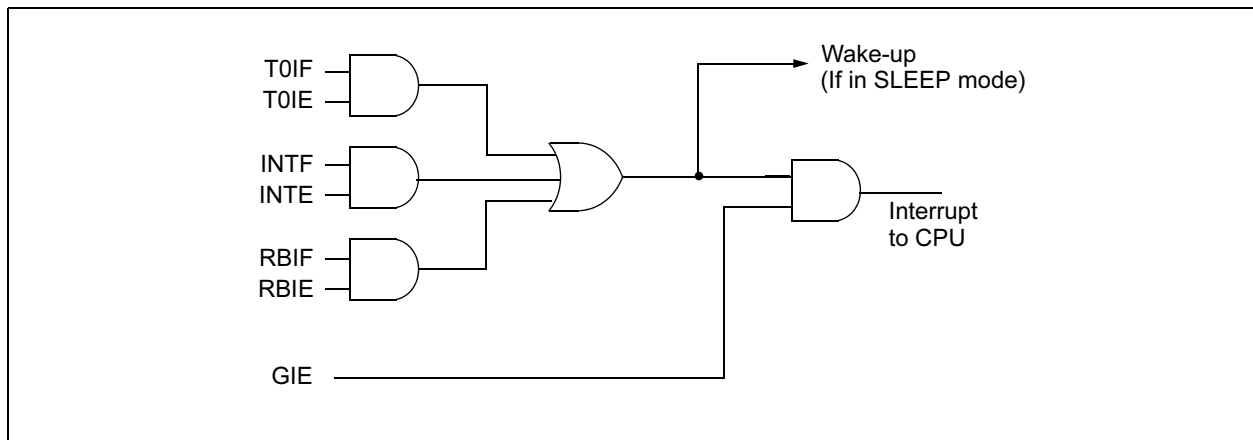
When an interrupt is responded to, the GIE is cleared to disable any further interrupt, the return address is pushed into the stack and the PC is loaded with 0004h. Once in the interrupt service routine the source(s) of the interrupt can be determined by polling the interrupt flag bits. The interrupt flag bit(s) must be cleared in software before re-enabling interrupts to avoid RB0/INT recursive interrupts.

For external interrupt events, such as the INT pin or PORTB change interrupt, the interrupt latency will be three or four instruction cycles. The exact latency depends when the interrupt event occurs (Figure 6-12). The latency is the same for one or two cycle instructions. Once in the interrupt service routine, the source(s) of the interrupt can be determined by polling the interrupt flag bits. The interrupt flag bit(s) must be cleared in software before re-enabling interrupts to avoid multiple interrupt requests. Individual interrupt flag bits are set regardless of the status of their corresponding mask bit or the GIE bit.

**Note 1:** Individual interrupt flag bits are set regardless of the status of their corresponding mask bit or the GIE bit.

**2:** When an instruction that clears the GIE bit is executed, any interrupts that were pending for execution in the next cycle are ignored. The CPU will execute a NOP in the cycle immediately following the instruction which clears the GIE bit. The interrupts which were ignored are still pending to be serviced when the GIE bit is set again.

**FIGURE 6-11: INTERRUPT LOGIC**



# PIC16C55X

## 6.5.1 RB0/INT INTERRUPT

An external interrupt on RB0/INT pin is edge triggered: either rising if INTEDG bit (OPTION<6>) is set, or falling if INTEDG bit is clear. When a valid edge appears on the RB0/INT pin, the INTF bit (INTCON<1>) is set. This interrupt can be disabled by clearing the INTE control bit (INTCON<4>). The INTF bit must be cleared in software in the interrupt service routine before re-enabling this interrupt. The RB0/INT interrupt can wake-up the processor from SLEEP, if the INTE bit was set prior to going into SLEEP. The status of the GIE bit decides whether or not the processor branches to the interrupt vector following wake-up. See Section 6.8 for details on SLEEP and Figure 6-14 for timing of wake-up from SLEEP through RB0/INT interrupt.

## 6.5.2 TMR0 INTERRUPT

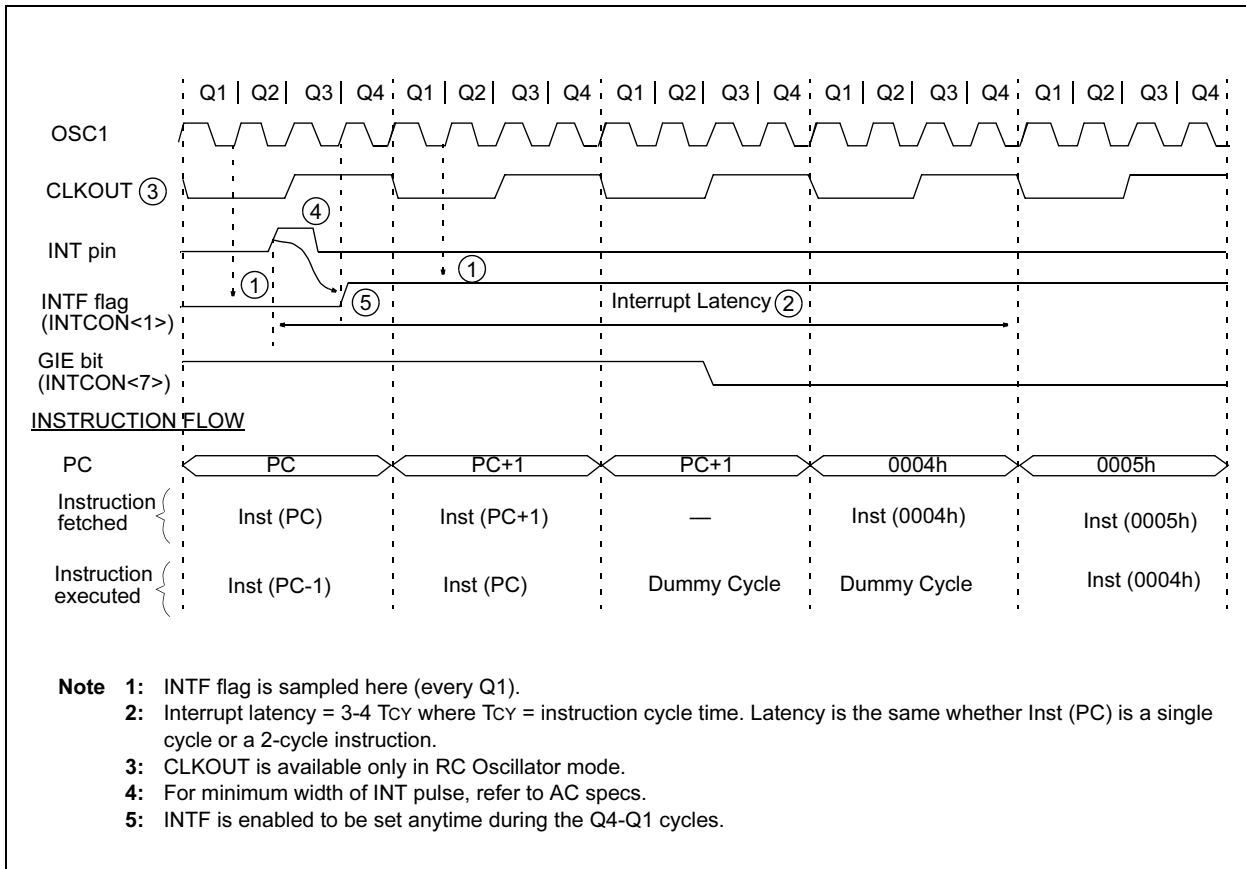
An overflow (FFh → 00h) in the TMR0 register will set the T0IF (INTCON<2>) bit. The interrupt can be enabled/disabled by setting/clearing T0IE (INTCON<5>) bit. For operation of the Timer0 module, see Section 7.0.

## 6.5.3 PORTB INTERRUPT

An input change on PORTB <7:4> sets the RBIF (INTCON<0>) bit. The interrupt can be enabled/disabled by setting/clearing the RBIE (INTCON<4>) bit. For operation of PORTB (Section 5.2).

**Note:** If a change on the I/O pin should occur when the read operation is being executed (start of the Q2 cycle), then the RBIF interrupt flag may get set.

**FIGURE 6-12: INT PIN INTERRUPT TIMING**



## 6.6 Context Saving During Interrupts

During an interrupt, only the return PC value is saved on the stack. Typically, users may wish to save key registers during an interrupt (e.g., W register and STATUS register). This will have to be implemented in software.

Example 6-1 stores and restores the STATUS and W registers. The user register, W\_TEMP, must be defined in both banks and must be defined at the same offset from the bank base address (i.e., W\_TEMP is defined at 0x20 in Bank 0 and it must also be defined at 0xA0 in Bank 1). The user register, STATUS\_TEMP, must be defined in Bank 0. The Example 6-1:

- Stores the W register
- Stores the STATUS register in Bank 0
- Executes the ISR code
- Restores the STATUS (and bank select bit register)
- Restores the W register

### EXAMPLE 6-1: SAVING THE STATUS AND W REGISTERS IN RAM

```

MOVWF  W_TEMP      ;copy W to TEMP
                  ;register, could be in
                  ;either bank
SWAPF  STATUS,W    ;swap STATUS to be
                  ;saved into W
BCF    STATUS,RP0  ;change to bank0
                  ;regardless of
                  ;current bank
MOVWF  STATUS_TEMP ;save STATUS to bank0
                  ;register
:
:
:
SWAPF  STATUS_TEMP,W;swap STATUS_TEMP
                  ;register into W, sets
                  ;bank to original state
MOVWF  STATUS      ;move W into STATUS
                  ;register
SWAPF  W_TEMP,F    ;swap W_TEMP
SWAPF  W_TEMP,W    ;swap W_TEMP into W
    
```

## 6.7 Watchdog Timer (WDT)

The Watchdog Timer is a free running on-chip RC oscillator which does not require any external components. This RC oscillator is separate from the RC oscillator of the CLKIN pin. That means that the WDT will run, even if the clock on the OSC1 and OSC2 pins of the device has been stopped, for example, by execution of a SLEEP instruction. During normal operation, a WDT timeout generates a device RESET. If the device is in SLEEP mode, a WDT timeout causes the device to wake-up and continue with normal operation. The WDT can be permanently disabled by programming the configuration bit WDTE as clear (Section 6.1).

### 6.7.1 WDT PERIOD

The WDT has a nominal timeout period of 18 ms, (with no prescaler). The timeout periods vary with temperature, VDD and process variations from part-to-part (see DC specs). If longer timeout periods are desired, a prescaler with a division ratio of up to 1:128 can be assigned to the WDT under software control by writing to the OPTION register. Thus, timeout periods up to 2.3 seconds can be realized.

The CLRWDT and SLEEP instructions clear the WDT and the postscaler, if assigned to the WDT, and prevent it from timing out and generating a device RESET.

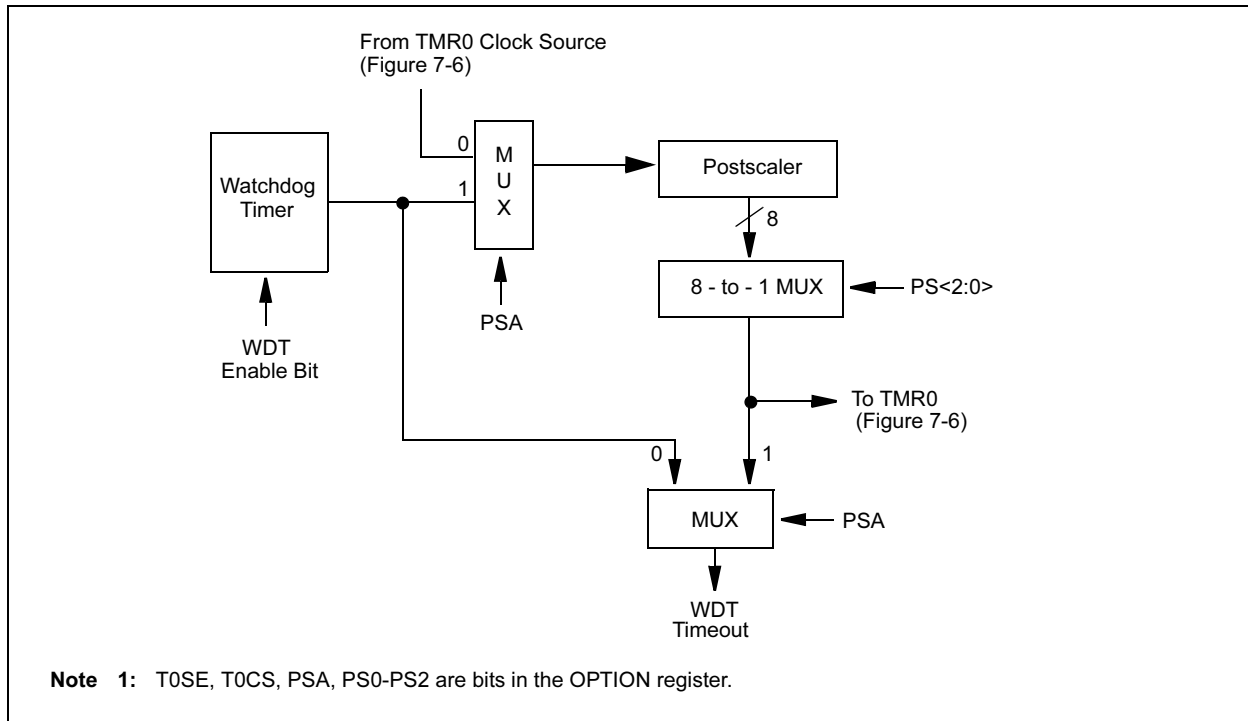
The  $\overline{TO}$  bit in the STATUS register will be cleared upon a Watchdog Timer timeout.

### 6.7.2 WDT PROGRAMMING CONSIDERATIONS

It should also be taken in account that under worst case conditions (VDD = Min., Temperature = Max., max. WDT prescaler) it may take several seconds before a WDT timeout occurs.

# PIC16C55X

**FIGURE 6-13: WATCHDOG TIMER BLOCK DIAGRAM**



**TABLE 6-7: SUMMARY OF WATCHDOG TIMER REGISTERS**

Address	Name	Bit 7	Bit 6	Bit 5	Bit 4	Bit 3	Bit 2	Bit 1	Bit 0	Value on POR	Value on all other RESETS
2007h	Config. bits	—	Reserved	CP1	CP0	PWRTE	WDTE	FOSC1	FOSC0		
81h	OPTION	RBPU	INTEDG	T0CS	T0SE	PSA	PS2	PS1	PS0	1111 1111	1111 1111

Legend: x = unknown, u = unchanged, q = value depends on condition, — = unimplemented, read as '0'.  
Shaded cells are not used by the Watchdog Timer.

## 6.8 Power-Down Mode (SLEEP)

The Power-down mode is entered by executing a SLEEP instruction.

If enabled, the Watchdog Timer will be cleared but keeps running, the PD bit in the STATUS register is cleared, the TO bit is set, and the oscillator driver is turned off. The I/O ports maintain the status they had, before SLEEP was executed (driving high, low, or hi-impedance).

For lowest current consumption in this mode, all I/O pins should be either at VDD, or VSS, with no external circuitry drawing current from the I/O pin. I/O pins that are hi-impedance inputs should be pulled high or low externally to avoid switching currents caused by floating inputs. The T0CKI input should also be at VDD or VSS for lowest current consumption. The contribution from on-chip pull-ups on PORTB should be considered.

The MCLR pin must be at a logic high level (VIHMC).

**Note:** It should be noted that a RESET generated by a WDT timeout does not drive MCLR pin low.

The first event will cause a device RESET. The two latter events are considered a continuation of program execution. The TO and PD bits in the STATUS register can be used to determine the cause of device RESET. PD bit, which is set on power-up is cleared when SLEEP is invoked. TO bit is cleared if WDT Wake-up occurred.

When the SLEEP instruction is being executed, the next instruction (PC + 1) is pre-fetched. For the device to wake-up through an interrupt event, the corresponding interrupt enable bit must be set (enabled). Wake-up is regardless of the state of the GIE bit. If the GIE bit is clear (disabled), the device continues execution at the instruction after the SLEEP instruction. If the GIE bit is set (enabled), the device executes the instruction after the SLEEP instruction and then branches to the interrupt address (0004h). In cases where the execution of the instruction following SLEEP is not desirable, the user should have an NOP after the SLEEP instruction.

**Note:** If the global interrupts are disabled (GIE is cleared), but any interrupt source has both its interrupt enable bit and the corresponding interrupt flag bits set, the device will immediately wake-up from SLEEP. The SLEEP instruction is completely executed.

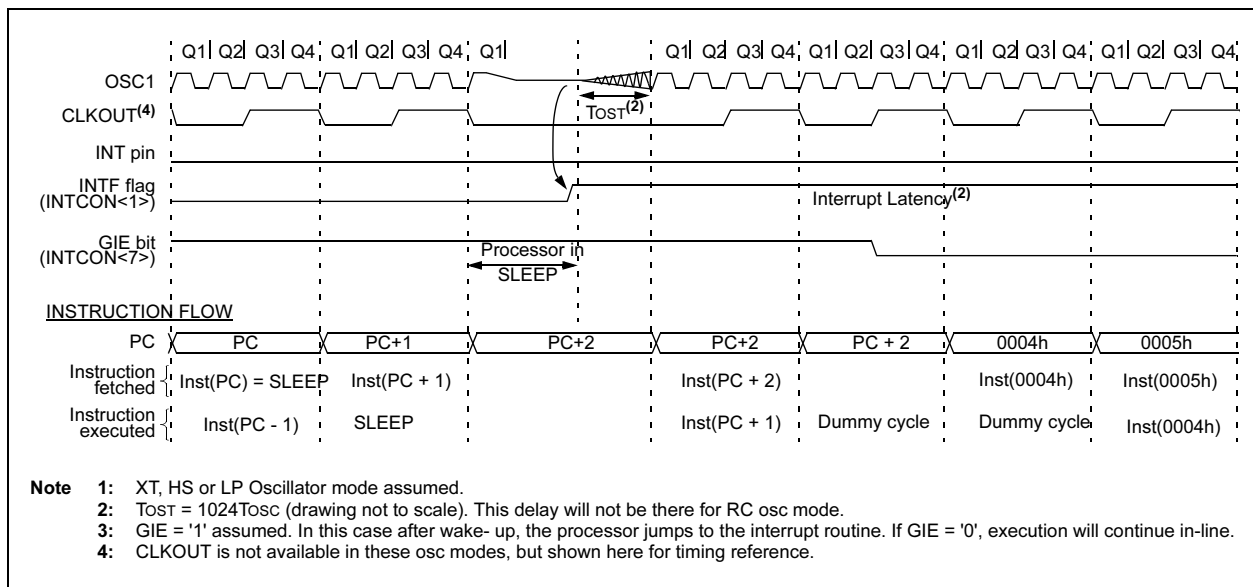
### 6.8.1 WAKE-UP FROM SLEEP

The device can wake-up from SLEEP through one of the following events:

1. External RESET input on MCLR pin
2. Watchdog Timer Wake-up (if WDT was enabled)
3. Interrupt from RB0/INT pin or RB Port change

The WDT is cleared when the device wakes-up from SLEEP, regardless of the source of wake-up.

**FIGURE 6-14: WAKE-UP FROM SLEEP THROUGH INTERRUPT**



# PIC16C55X

## 6.9 Code Protection

If the code protection bit(s) have not been programmed, the on-chip program memory can be read out for verification purposes.

**Note:** Microchip does not recommend code protecting windowed devices.

## 6.10 ID Locations

Four memory locations (2000h-2003h) are designated as ID locations where the user can store checksum or other code-identification numbers. These locations are not accessible during normal execution but are readable and writable during program/verify.

## 6.11 In-Circuit Serial Programming™

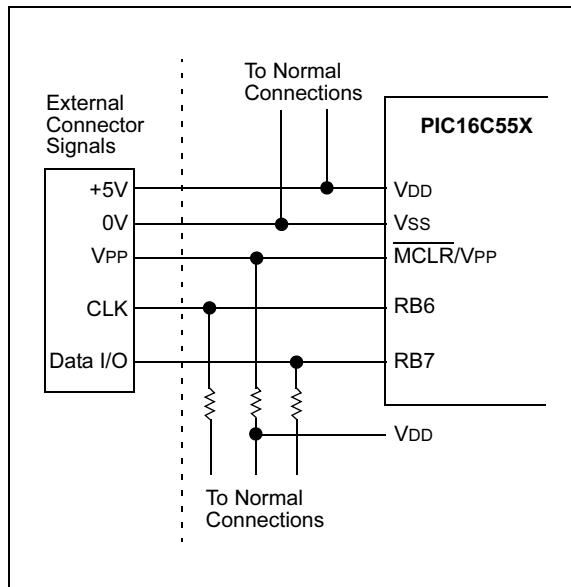
The PIC16C55X microcontrollers can be serially programmed while in the end application circuit. This is simply done with two lines for clock and data, and three other lines for power, ground, and the programming voltage. This allows customers to manufacture boards with unprogrammed devices, and then program the microcontroller just before shipping the product. This also allows the most recent firmware or a custom firmware to be programmed.

The device is placed into a Program/Verify mode by holding the RB6 and RB7 pins low while raising the MCLR (VPP) pin from  $V_{IL}$  to  $V_{IH}$  (see programming specification). RB6 becomes the programming clock and RB7 becomes the programming data. Both RB6 and RB7 are Schmitt Trigger inputs in this mode.

After RESET, to place the device into Programming/Verify mode, the program counter (PC) is at location 00h. A 6-bit command is then supplied to the device. Depending on the command, 14 bits of program data are then supplied to or from the device, depending if the command was a load or a read. For complete details of serial programming, please refer to the PIC16C6X/7X Programming Specifications (Literature #DS30228).

A typical in-circuit serial programming connection is shown in Figure 6-15.

FIGURE 6-15: TYPICAL IN-CIRCUIT SERIAL PROGRAMMING CONNECTION





## 7.0 TIMER0 MODULE

The Timer0 module timer/counter has the following features:

- 8-bit timer/counter
- Readable and writable
- 8-bit software programmable prescaler
- Internal or external clock select
- Interrupt on overflow from FFh to 00h
- Edge select for external clock

Figure 7-1 is a simplified block diagram of the Timer0 module.

Timer mode is selected by clearing the T0CS bit (OPTION<5>). In Timer mode, the TMR0 will increment every instruction cycle (without prescaler). If Timer0 is written, the increment is inhibited for the following two cycles (Figure 7-2 and Figure 7-3). The user can work around this by writing an adjusted value to TMR0.

Counter mode is selected by setting the T0CS bit. In this mode Timer0 will increment either on every rising or falling edge of pin RA4/T0CKI. The incrementing edge is determined by the source edge (T0SE) control

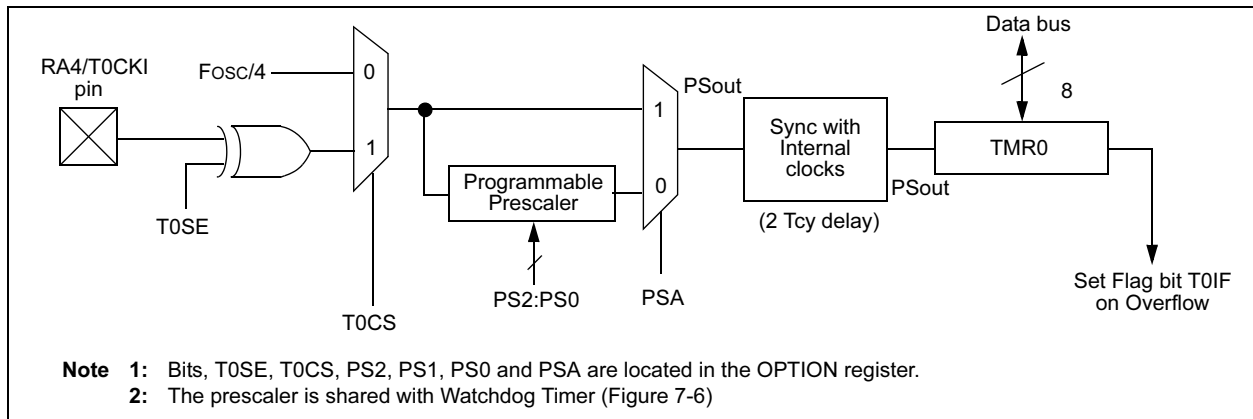
bit (OPTION<4>). Clearing the T0SE bit selects the rising edge. Restrictions on the external clock input are discussed in detail in Section 7.2.

The prescaler is shared between the Timer0 module and the Watchdog Timer. The prescaler assignment is controlled in software by the control bit PSA (OPTION<3>). Clearing the PSA bit will assign the prescaler to Timer0. The prescaler is not readable or writable. When the prescaler is assigned to the Timer0 module, prescale value of 1:2, 1:4, ..., 1:256 are selectable. Section 7.3 details the operation of the prescaler.

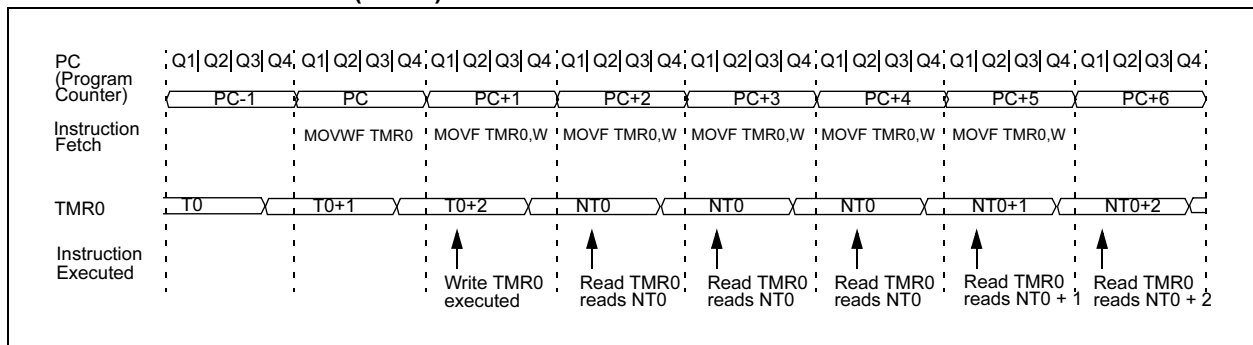
### 7.1 TIMER0 Interrupt

Timer0 interrupt is generated when the TMR0 register timer/counter overflows from FFh to 00h. This overflow sets the T0IF bit. The interrupt can be masked by clearing the T0IE bit (INTCON<5>). The T0IF bit (INTCON<2>) must be cleared in software by the Timer0 module interrupt service routine before re-enabling this interrupt. The Timer0 interrupt cannot wake the processor from SLEEP since the timer is shut off during SLEEP. See Figure 7-4 for Timer0 interrupt timing.

**FIGURE 7-1: TIMER0 BLOCK DIAGRAM**

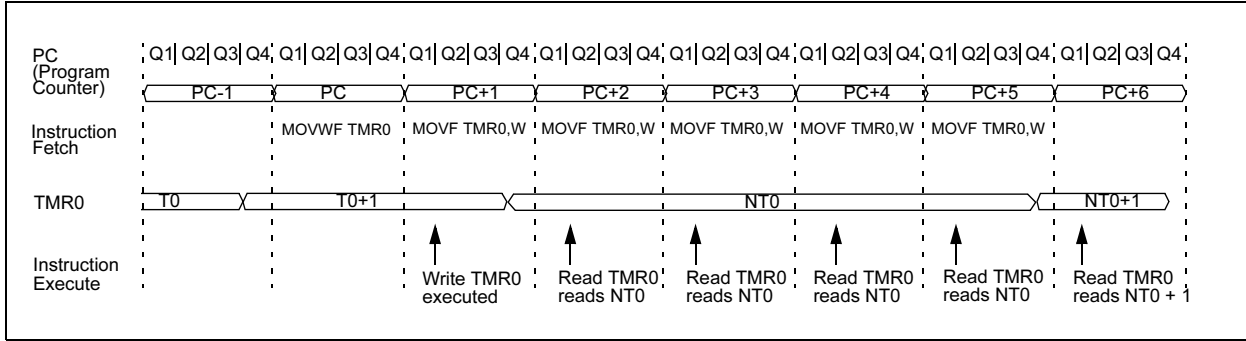


**FIGURE 7-2: TIMER0 (TMR0) TIMING: INTERNAL CLOCK/NO PRESCALER**

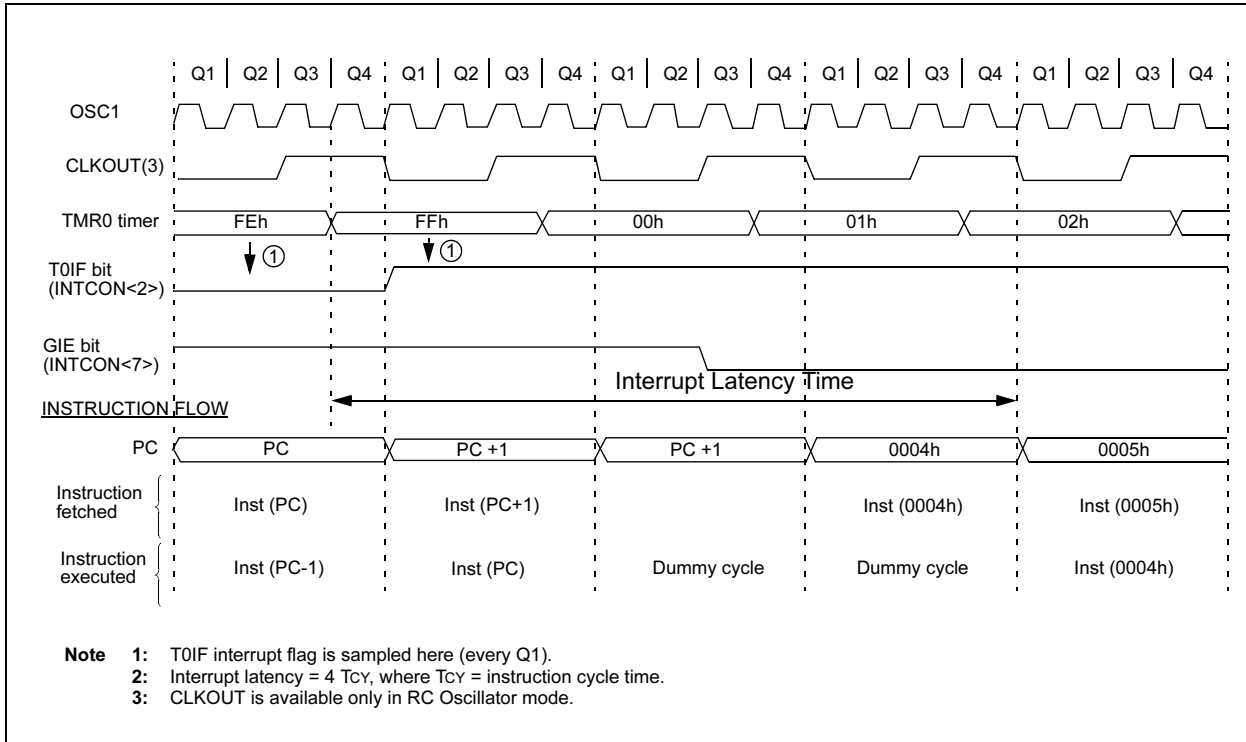


# PIC16C55X

**FIGURE 7-3: TIMER0 TIMING: INTERNAL CLOCK/PRESCALE 1:2**



**FIGURE 7-4: TIMER0 INTERRUPT TIMING**



## 7.2 Using Timer0 with External Clock

When an external clock input is used for Timer0, it must meet certain requirements. The external clock requirement is due to internal phase clock (TOSC) synchronization. Also, there is a delay in the actual incrementing of Timer0 after synchronization.

### 7.2.1 EXTERNAL CLOCK SYNCHRONIZATION

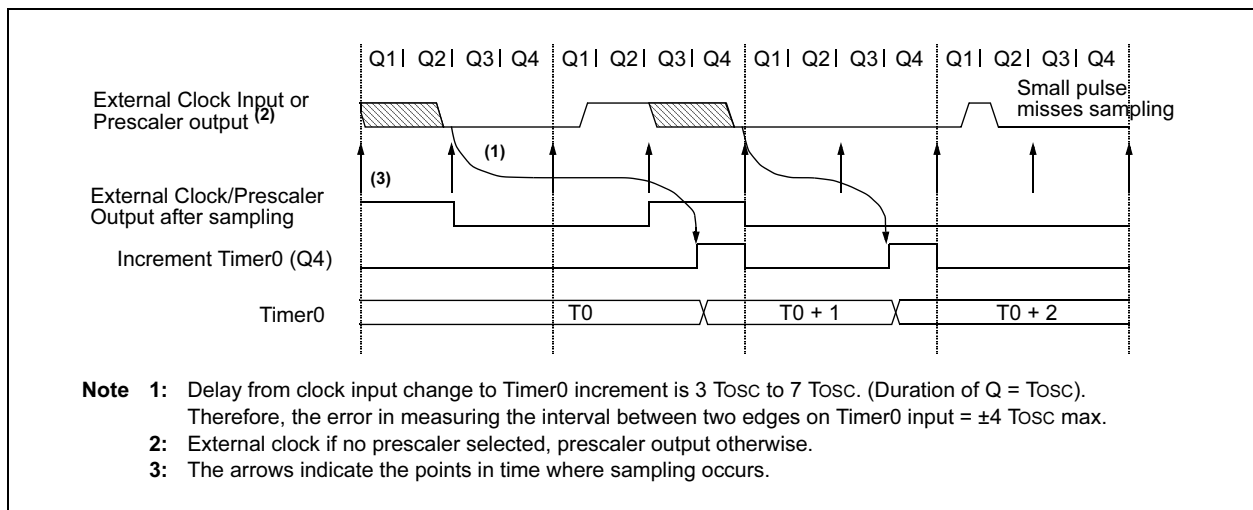
When no prescaler is used, the external clock input is the same as the prescaler output. The synchronization of T0CKI with the internal phase clocks is accomplished by sampling the prescaler output on the Q2 and Q4 cycles of the internal phase clocks (Figure 7-5). Therefore, it is necessary for T0CKI to be high for at least 2TOSC (and a small RC delay of 20 ns) and low for at least 2TOSC (and a small RC delay of 20 ns). Refer to the electrical specification of the desired device.

When a prescaler is used, the external clock input is divided by the asynchronous ripple-counter type prescaler so that the prescaler output is symmetrical. For the external clock to meet the sampling requirement, the ripple-counter must be taken into account. Therefore, it is necessary for T0CKI to have a period of at least 4TOSC (and a small RC delay of 40 ns) divided by the prescaler value. The only requirement on T0CKI high and low time is that they do not violate the minimum pulse width requirement of 10 ns. Refer to parameters 40, 41 and 42 in the electrical specification of the desired device.

### 7.2.2 TIMER0 INCREMENT DELAY

Since the prescaler output is synchronized with the internal clocks, there is a small delay from the time the external clock edge occurs to the time the TMR0 is actually incremented. Figure 7-5 shows the delay from the external clock edge to the timer incrementing.

**FIGURE 7-5: TIMER0 TIMING WITH EXTERNAL CLOCK**



## 7.3 Prescaler

An 8-bit counter is available as a prescaler for the Timer0 module, or as a postscaler for the Watchdog Timer, respectively (Figure 7-6). For simplicity, this counter is being referred to as “prescaler” throughout this data sheet.

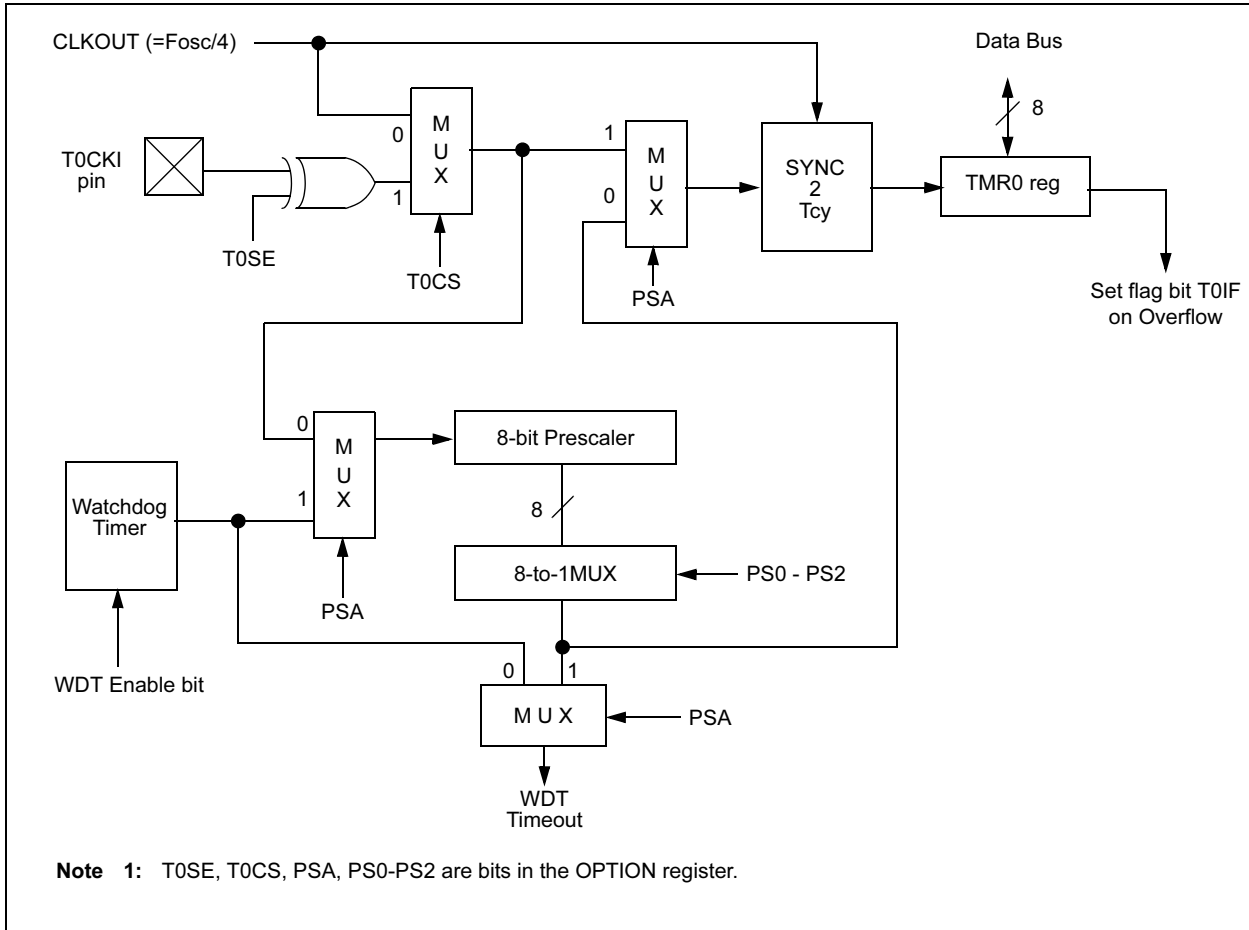
**Note:** There is only one prescaler available which is mutually exclusive between the Timer0 module and the Watchdog Timer. Thus, a prescaler assignment for the Timer0 module means that there is no prescaler for the Watchdog Timer, and vice-versa.

The PSA and PS2:PS0 bits (OPTION<3:0>) determine the prescaler assignment and prescale ratio.

When assigned to the Timer0 module, all instructions writing to the TMR0 register (e.g., CLRWF 1, MOVWF 1, BSF 1,x...etc.) will clear the prescaler. When assigned to WDT, a CLRWDT instruction will clear the prescaler along with the Watchdog Timer. The prescaler is not readable or writable.

# PIC16C55X

**FIGURE 7-6: BLOCK DIAGRAM OF THE TIMER0/WDT PRESCALER**



## 7.3.1 SWITCHING PRESCALER ASSIGNMENT

The prescaler assignment is fully under software control (i.e., it can be changed “on the fly” during program execution). To avoid an unintended device RESET, the following instruction sequence (Example 7-1) must be executed when changing the prescaler assignment from Timer0 to WDT. Lines 5-7 are required only if the desired postscale rate is 1:1 (PS<2:0> = 000) or 1:2 (PS<2:0> = 001).

### EXAMPLE 7-1: CHANGING PRESCALER (TIMER0→WDT)

```
BCF STATUS, RP0 ;Skip if already in
                    ;Bank 0 CLRWDT Clear WDT
CLRF TMR0         ;Clear TMR0 & Prescaler
BSF STATUS, RP0  ;Bank 1
MOVLW '00101111'b ;These 3 lines (5, 6, 7)
MOVWF OPTION     ;Are required only if
                    ;Desired PS<2:0> are
                    ;CLRWDT 000 or 001
MOVLW '00101xxx'b ;Set Postscaler to
MOVWF OPTION     ;Desired WDT rate
BCF STATUS, RP0 ;Return to Bank 0
```

To change prescaler from the WDT to the TMR0 module use the sequence shown in Example 7-2. This precaution must be taken even if the WDT is disabled.

### EXAMPLE 7-2: CHANGING PRESCALER (WDT→TIMER0)

```
CLRWDT           ;Clear WDT and
                    ;prescaler
BSF STATUS, RP0
MOVLW b'xxxx0xxx' ;Select TMR0, new
                    ;prescale value and
                    ;clock source
MOVWF OPTION
BCF STATUS, RP0
```

**TABLE 7-1: REGISTERS ASSOCIATED WITH TIMER0**

Address	Name	Bit 7	Bit 6	Bit 5	Bit 4	Bit 3	Bit 2	Bit 1	Bit 0	Value on POR	Value on All Other RESETS
01h	TMR0	Timer0 module's register								xxxx xxxx	uuuu uuuu
0Bh/8Bh	INTCON	GIE	Reserved	TOIE	INTE	RBIE	TOIF	INTF	RBIF	0000 000x	0000 000x
81h	OPTION	$\overline{\text{RBPU}}$	INTEDG	T0CS	T0SE	PSA	PS2	PS1	PS0	1111 1111	1111 1111
85h	TRISA	—	—	—	TRISA4	TRISA3	TRISA2	TRISA1	TRISA0	---1 1111	---1 1111

Legend: — = Unimplemented locations, read as '0',  
**Note 1:** Shaded bits are not used by TMR0 module.

# PIC16C55X

---

NOTES:

## 8.0 INSTRUCTION SET SUMMARY

Each PIC16C55X instruction is a 14-bit word divided into an OPCODE which specifies the instruction type and one or more operands which further specify the operation of the instruction. The PIC16C55X instruction set summary in Table 8-2 lists **byte-oriented**, **bit-oriented**, and **literal and control** operations. Table 8-1 shows the opcode field descriptions.

For **byte-oriented** instructions, 'f' represents a file register designator and 'd' represents a destination designator. The file register designator specifies which file register is to be used by the instruction.

The destination designator specifies where the result of the operation is to be placed. If 'd' is zero, the result is placed in the W register. If 'd' is one, the result is placed in the file register specified in the instruction.

For **bit-oriented** instructions, 'b' represents a bit field designator which selects the number of the bit affected by the operation, while 'f' represents the number of the file in which the bit is located.

For **literal and control** operations, 'k' represents an eight or eleven bit constant or literal value.

**TABLE 8-1: OPCODE FIELD DESCRIPTIONS**

Field	Description
f	Register file address (0x00 to 0x7F)
W	Working register (accumulator)
b	Bit address within an 8-bit file register
k	Literal field, constant data or label
x	Don't care location (= 0 or 1) The assembler will generate code with x = 0. It is the recommended form of use for compatibility with all Microchip software tools.
d	Destination select; d = 0: store result in W, d = 1: store result in file register f. Default is d = 1
label	Label name
TOS	Top of Stack
PC	Program Counter
PCLATH	Program Counter High Latch
GIE	Global Interrupt Enable bit
WDT	Watchdog Timer/Counter
TO	Timeout bit
PD	Power-down bit
dest	Destination either the W register or the specified register file location
[ ]	Options
( )	Contents
→	Assigned to
< >	Register bit field
∈	In the set of
<i>italics</i>	User defined term (font is courier)

The instruction set is highly orthogonal and is grouped into three basic categories:

- **Byte-oriented** operations
- **Bit-oriented** operations
- **Literal and control** operations

All instructions are executed within one single instruction cycle, unless a conditional test is true or the program counter is changed as a result of an instruction. In this case, the execution takes two instruction cycles with the second cycle executed as a NOP. One instruction cycle consists of four oscillator periods. Thus, for an oscillator frequency of 4 MHz, the normal instruction execution time is 1 μs. If a conditional test is true or the program counter is changed as a result of an instruction, the instruction execution time is 2 μs.

Table 8-1 lists the instructions recognized by the MPASM™ assembler.

Figure 8-1 shows the three general formats that the instructions can have.

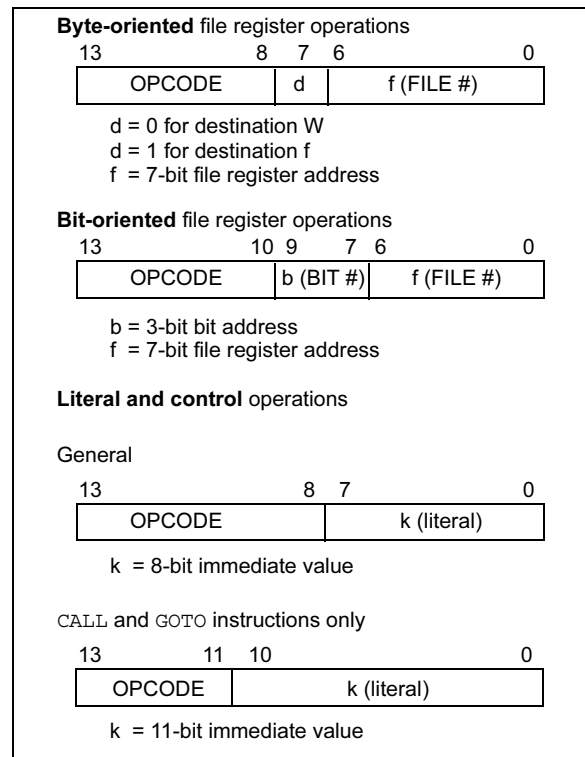
**Note:** To maintain upward compatibility with future PICmicro® products, do not use the OPTION and TRIS instructions.

All examples use the following format to represent a hexadecimal number:

0xhh

where h signifies a hexadecimal digit.

**FIGURE 8-1: GENERAL FORMAT FOR INSTRUCTIONS**



# PIC16C55X

**TABLE 8-2: PIC16C55X INSTRUCTION SET**

Mnemonic, Operands	Description	Cycles	14-Bit Opcode				Status Affected	Notes	
			MSb		LSb				
<b>BYTE-ORIENTED FILE REGISTER OPERATIONS</b>									
ADDWF	f, d	Add W and f	1	00	0111	dfff	ffff	C,DC,Z	1,2
ANDWF	f, d	AND W with f	1	00	0101	dfff	ffff	Z	1,2
CLRF	f	Clear f	1	00	0001	1fff	ffff	Z	2
CLRWF	-	Clear W	1	00	0001	0000	0011	Z	
COMF	f, d	Complement f	1	00	1001	dfff	ffff	Z	1,2
DECWF	f, d	Decrement f	1	00	0011	dfff	ffff	Z	1,2
DECFSZ	f, d	Decrement f, Skip if 0	1(2)	00	1011	dfff	ffff		1,2,3
INCF	f, d	Increment f	1	00	1010	dfff	ffff	Z	1,2
INCFSZ	f, d	Increment f, Skip if 0	1(2)	00	1111	dfff	ffff		1,2,3
IORWF	f, d	Inclusive OR W with f	1	00	0100	dfff	ffff	Z	1,2
MOVF	f, d	Move f	1	00	1000	dfff	ffff	Z	1,2
MOVWF	f	Move W to f	1	00	0000	1fff	ffff		
NOP	-	No Operation	1	00	0000	0xx0	0000		
RLF	f, d	Rotate Left f through Carry	1	00	1101	dfff	ffff	C	1,2
RRF	f, d	Rotate Right f through Carry	1	00	1100	dfff	ffff	C	1,2
SUBWF	f, d	Subtract W from f	1	00	0010	dfff	ffff	C,DC,Z	1,2
SWAPF	f, d	Swap nibbles in f	1	00	1110	dfff	ffff		1,2
XORWF	f, d	Exclusive OR W with f	1	00	0110	dfff	ffff	Z	1,2
<b>BIT-ORIENTED FILE REGISTER OPERATIONS</b>									
BCF	f, b	Bit Clear f	1	01	00bb	bfff	ffff		1,2
BSF	f, b	Bit Set f	1	01	01bb	bfff	ffff		1,2
BTFSC	f, b	Bit Test f, Skip if Clear	1(2)	01	10bb	bfff	ffff		3
BTFSS	f, b	Bit Test f, Skip if Set	1(2)	01	11bb	bfff	ffff		3
<b>LITERAL AND CONTROL OPERATIONS</b>									
ADDLW	k	Add literal and W	1	11	111x	kkkk	kkkk	C,DC,Z	
ANDLW	k	AND literal with W	1	11	1001	kkkk	kkkk	Z	
CALL	k	Call subroutine	2	10	0kkk	kkkk	kkkk		
CLRWDT	-	Clear Watchdog Timer	1	00	0000	0110	0100	$\overline{TO,PD}$	
GOTO	k	Go to address	2	10	1kkk	kkkk	kkkk		
IORLW	k	Inclusive OR literal with W	1	11	1000	kkkk	kkkk	Z	
MOVLW	k	Move literal to W	1	11	00xx	kkkk	kkkk		
RETFIE	-	Return from interrupt	2	00	0000	0000	1001		
RETLW	k	Return with literal in W	2	11	01xx	kkkk	kkkk		
RETURN	-	Return from Subroutine	2	00	0000	0000	1000		
SLEEP	-	Go into Standby mode	1	00	0000	0110	0011	$\overline{TO,PD}$	
SUBLW	k	Subtract W from literal	1	11	110x	kkkk	kkkk	C,DC,Z	
XORLW	k	Exclusive OR literal with W	1	11	1010	kkkk	kkkk	Z	

- Note 1:** When an I/O register is modified as a function of itself ( e.g., `MOVF PORTB, 1`), the value used will be that value present on the pins themselves. For example, if the data latch is '1' for a pin configured as input and is driven low by an external device, the data will be written back with a '0'.
- Note 2:** If this instruction is executed on the TMR0 register (and, where applicable, d = 1), the prescaler will be cleared if assigned to the Timer0 Module.
- Note 3:** If Program Counter (PC) is modified or a conditional test is true, the instruction requires two cycles. The second cycle is executed as a NOP.



## 8.1 Instruction Descriptions

### ADDLW Add Literal and W

Syntax: `[label] ADDLW k`

Operands:  $0 \leq k \leq 255$

Operation:  $(W) + k \rightarrow (W)$

Status Affected: C, DC, Z

Encoding: 

11	111x	kkkk	kkkk
----	------	------	------

Description: The contents of the W register are added to the eight bit literal 'k' and the result is placed in the W register.

Words: 1

Cycles: 1

Example `ADDLW 0x15`

Before Instruction

W = 0x10

After Instruction

W = 0x25

### ANDLW AND Literal with W

Syntax: `[label] ANDLW k`

Operands:  $0 \leq k \leq 255$

Operation:  $(W) .AND. (k) \rightarrow (W)$

Status Affected: Z

Encoding: 

11	1001	kkkk	kkkk
----	------	------	------

Description: The contents of W register are AND'ed with the eight bit literal 'k'. The result is placed in the W register.

Words: 1

Cycles: 1

Example `ANDLW 0x5F`

Before Instruction

W = 0xA3

After Instruction

W = 0x03

### ADDWF Add W and f

Syntax: `[label] ADDWF f,d`

Operands:  $0 \leq f \leq 127$   
 $d \in [0,1]$

Operation:  $(W) + (f) \rightarrow (dest)$

Status Affected: C, DC, Z

Encoding: 

00	0111	dfff	ffff
----	------	------	------

Description: Add the contents of the W register with register 'f'. If 'd' is 0 the result is stored in the W register. If 'd' is 1 the result is stored back in register 'f'.

Words: 1

Cycles: 1

Example `ADDWF FSR, 0`

Before Instruction

W = 0x17

FSR = 0xC2

After Instruction

W = 0xD9

FSR = 0xC2

### ANDWF AND W with f

Syntax: `[label] ANDWF f,d`

Operands:  $0 \leq f \leq 127$   
 $d \in [0,1]$

Operation:  $(W) .AND. (f) \rightarrow (dest)$

Status Affected: Z

Encoding: 

00	0101	dfff	ffff
----	------	------	------

Description: AND the W register with register 'f'. If 'd' is 0 the result is stored in the W register. If 'd' is 1 the result is stored back in register 'f'.

Words: 1

Cycles: 1

Example `ANDWF FSR, 1`

Before Instruction

W = 0x17

FSR = 0xC2

After Instruction

W = 0x17

FSR = 0x02

# PIC16C55X

## BCF Bit Clear f

Syntax: `[label] BCF f,b`

Operands:  $0 \leq f \leq 127$   
 $0 \leq b \leq 7$

Operation:  $0 \rightarrow (f<b>)$

Status Affected: None

Encoding: 

01	00bb	bfff	ffff
----	------	------	------

Description: Bit 'b' in register 'f' is cleared.

Words: 1

Cycles: 1

Example `BCF FLAG_REG, 7`

Before Instruction  
`FLAG_REG = 0xC7`  
 After Instruction  
`FLAG_REG = 0x47`

## BSF Bit Set f

Syntax: `[label] BSF f,b`

Operands:  $0 \leq f \leq 127$   
 $0 \leq b \leq 7$

Operation:  $1 \rightarrow (f<b>)$

Status Affected: None

Encoding: 

01	01bb	bfff	ffff
----	------	------	------

Description: Bit 'b' in register 'f' is set.

Words: 1

Cycles: 1

Example `BSF FLAG_REG, 7`

Before Instruction  
`FLAG_REG = 0x0A`  
 After Instruction  
`FLAG_REG = 0x8A`

## BTFSC Bit Test, Skip if Clear

Syntax: `[label] BTFSC f,b`

Operands:  $0 \leq f \leq 127$   
 $0 \leq b \leq 7$

Operation: skip if  $(f<b>) = 0$

Status Affected: None

Encoding: 

01	10bb	bfff	ffff
----	------	------	------

Description: If bit 'b' in register 'f' is '0' then the next instruction is skipped. If bit 'b' is '0' then the next instruction fetched during the current instruction execution is discarded, and a NOP is executed instead, making this a two-cycle instruction.

Words: 1

Cycles: 1(2)

Example

```

HERE    BTFSC    FLAG,1
FALSE   GOTO    PROCESS_CODE
TRUE    .
        .
        .
  
```

Before Instruction  
`PC = address HERE`  
 After Instruction  
 if `FLAG<1> = 0,`  
`PC = address TRUE`  
 if `FLAG<1> = 1,`  
`PC = address FALSE`

## **BTFSS**      **Bit Test f, Skip if Set**

Syntax:            `[ label ] BTFSS f,b`

Operands:         $0 \leq f \leq 127$   
 $0 \leq b < 7$

Operation:        skip if  $(f < b) = 1$

Status Affected: None

Encoding:        

01	11bb	bfff	ffff
----	------	------	------

Description:     If bit 'b' in register 'f' is '1' then the next instruction is skipped.  
 If bit 'b' is '1', then the next instruction fetched during the current instruction execution, is discarded and a NOP is executed instead, making this a two-cycle instruction.

Words:            1

Cycles:           1(2)

Example

```

HERE    BTFSS    FLAG,1
FALSE   GOTO    PROCESS_CODE
TRUE    .
        .
        .
  
```

Before Instruction  
 PC = address HERE

After Instruction

if  $FLAG < 1 > = 0$ ,  
 PC = address FALSE

if  $FLAG < 1 > = 1$ ,  
 PC = address TRUE

## **CALL**            **Call Subroutine**

Syntax:            `[ label ] CALL k`

Operands:         $0 \leq k \leq 2047$

Operation:         $(PC) + 1 \rightarrow TOS$ ,  
 $k \rightarrow PC < 10:0 >$ ,  
 $(PCLATH < 4:3 >) \rightarrow PC < 12:11 >$

Status Affected: None

Encoding:        

10	0kkk	kkkk	kkkk
----	------	------	------

Description:     Call Subroutine. First, return address  $(PC+1)$  is pushed onto the stack. The eleven bit immediate address is loaded into PC bits  $< 10:0 >$ . The upper bits of the PC are loaded from PCLATH. CALL is a two-cycle instruction.

Words:            1

Cycles:           2

Example

```

HERE    CALL    THERE
  
```

Before Instruction  
 PC = Address HERE

After Instruction  
 PC = Address THERE  
 TOS = Address HERE+1

## **CLRF**            **Clear f**

Syntax:            `[ label ] CLRF f`

Operands:         $0 \leq f \leq 127$

Operation:         $00h \rightarrow (f)$   
 $1 \rightarrow Z$

Status Affected: Z

Encoding:        

00	0001	1fff	ffff
----	------	------	------

Description:     The contents of register 'f' are cleared and the Z bit is set.

Words:            1

Cycles:           1

Example

```

CLRF    FLAG_REG
  
```

Before Instruction  
 FLAG\_REG=0x5A

After Instruction  
 FLAG\_REG=0x00  
 Z        =1

# PIC16C55X

CLR W	Clear W				
Syntax:	[ <i>label</i> ] CLRW				
Operands:	None				
Operation:	00h → (W) 1 → Z				
Status Affected:	Z				
Encoding:	<table border="1"><tr><td>00</td><td>0001</td><td>0000</td><td>0011</td></tr></table>	00	0001	0000	0011
00	0001	0000	0011		
Description:	W register is cleared. Zero bit (Z) is set.				
Words:	1				
Cycles:	1				
Example	<pre> CLR W Before Instruction W = 0x5A After Instruction W = 0x00 Z = 1 </pre>				

COMF	Complement f				
Syntax:	[ <i>label</i> ] COMF f,d				
Operands:	$0 \leq f \leq 127$ $d \in [0,1]$				
Operation:	(f) → (dest)				
Status Affected:	Z				
Encoding:	<table border="1"><tr><td>00</td><td>1001</td><td>dfff</td><td>ffff</td></tr></table>	00	1001	dfff	ffff
00	1001	dfff	ffff		
Description:	The contents of register 'f' are complemented. If 'd' is 0 the result is stored in W. If 'd' is 1 the result is stored back in register 'f'.				
Words:	1				
Cycles:	1				
Example	<pre> COMF REG1,0 Before Instruction REG1 = 0x13 After Instruction REG1 = 0x13 W = 0xEC </pre>				

CLRWD T	Clear Watchdog Timer				
Syntax:	[ <i>label</i> ] CLRWD T				
Operands:	None				
Operation:	00h → WDT 0 → WDT prescaler, 1 → $\overline{TO}$ 1 → $\overline{PD}$				
Status Affected:	$\overline{TO}$ , $\overline{PD}$				
Encoding:	<table border="1"><tr><td>00</td><td>0000</td><td>0110</td><td>0100</td></tr></table>	00	0000	0110	0100
00	0000	0110	0100		
Description:	CLRWD T instruction resets the Watchdog Timer. It also resets the prescaler of the WDT. Status bits $\overline{TO}$ and $\overline{PD}$ are set.				
Words:	1				
Cycles:	1				
Example	<pre> CLRWD T Before Instruction WDT counter = ? After Instruction WDT counter = 0x00 WDT prescaler = 0 <math>\overline{TO}</math> = 1 <math>\overline{PD}</math> = 1 </pre>				

DECF	Decrement f				
Syntax:	[ <i>label</i> ] DECF f,d				
Operands:	$0 \leq f \leq 127$ $d \in [0,1]$				
Operation:	(f) - 1 → (dest)				
Status Affected:	Z				
Encoding:	<table border="1"><tr><td>00</td><td>0011</td><td>dfff</td><td>ffff</td></tr></table>	00	0011	dfff	ffff
00	0011	dfff	ffff		
Description:	Decrement register 'f'. If 'd' is 0 the result is stored in the W register. If 'd' is 1 the result is stored back in register 'f'.				
Words:	1				
Cycles:	1				
Example	<pre> DECF CNT, 1 Before Instruction CNT = 0x01 Z = 0 After Instruction CNT = 0x00 Z = 1 </pre>				

## DECFSZ      Decrement f, Skip if 0

**Syntax:**            `[label] DECFSZ f,d`

**Operands:**         $0 \leq f \leq 127$   
 $d \in [0,1]$

**Operation:**         $(f) - 1 \rightarrow (\text{dest});$     skip if result = 0

**Status Affected:**    None

**Encoding:**

00	1011	dfff	ffff
----	------	------	------

**Description:**      The contents of register 'f' are decremented. If 'd' is 0 the result is placed in the W register. If 'd' is 1 the result is placed back in register 'f'. If the result is 0, the next instruction, which is already fetched, is discarded. A NOP is executed instead making it a two-cycle instruction.

**Words:**            1

**Cycles:**            1(2)

**Example**

```

HERE      DECFSZ    CNT, 1
            GOTO     LOOP
CONTINUE •
            •
            •

```

**Before Instruction**  
PC = address HERE

**After Instruction**  
CNT = CNT - 1  
if CNT = 0,  
PC = address CONTINUE  
if CNT ≠ 0,  
PC = address HERE+1

## GOTO            Unconditional Branch

**Syntax:**            `[label] GOTO k`

**Operands:**         $0 \leq k \leq 2047$

**Operation:**         $k \rightarrow PC<10:0>$   
PCLATH<4:3>  $\rightarrow PC<12:11>$

**Status Affected:**    None

**Encoding:**

10	1kkk	kkkk	kkkk
----	------	------	------

**Description:**      GOTO is an unconditional branch. The eleven bit immediate value is loaded into PC bits <10:0>. The upper bits of PC are loaded from PCLATH<4:3>. GOTO is a two-cycle instruction.

**Words:**            1

**Cycles:**            2

**Example**            `GOTO THERE`

**After Instruction**  
PC = Address THERE

## INCF            Increment f

**Syntax:**            `[label] INCF f,d`

**Operands:**         $0 \leq f \leq 127$   
 $d \in [0,1]$

**Operation:**         $(f) + 1 \rightarrow (\text{dest})$

**Status Affected:**    Z

**Encoding:**

00	1010	dfff	ffff
----	------	------	------

**Description:**      The contents of register 'f' are incremented. If 'd' is 0 the result is placed in the W register. If 'd' is 1 the result is placed back in register 'f'.

**Words:**            1

**Cycles:**            1

**Example**            `INCF    CNT,    1`

**Before Instruction**  
CNT = 0xFF  
Z = 0

**After Instruction**  
CNT = 0x00  
Z = 1

# PIC16C55X

## INCFSZ Increment f, Skip if 0

**Syntax:** `[label] INCFSZ f,d`

**Operands:**  $0 \leq f \leq 127$   
 $d \in [0,1]$

**Operation:**  $(f) + 1 \rightarrow (\text{dest})$ , skip if result = 0

**Status Affected:** None

**Encoding:**

00	1111	dfff	ffff
----	------	------	------

**Description:** The contents of register 'f' are incremented. If 'd' is 0 the result is placed in the W register. If 'd' is 1 the result is placed back in register 'f'. If the result is 0, the next instruction, which is already fetched, is discarded. A NOP is executed instead making it a two-cycle instruction.

**Words:** 1

**Cycles:** 1(2)

**Example**

```

HERE      INCFSZ   CNT, 1
          GOTO    LOOP
CONTINUE  .
          .
          .
  
```

**Before Instruction**  
PC = address HERE

**After Instruction**  
CNT = CNT + 1  
if CNT = 0,  
PC = address CONTINUE  
if CNT ≠ 0,  
PC = address HERE + 1

## IORWF Inclusive OR W with f

**Syntax:** `[label] IORWF f,d`

**Operands:**  $0 \leq f \leq 127$   
 $d \in [0,1]$

**Operation:**  $(W) .OR. (f) \rightarrow (\text{dest})$

**Status Affected:** Z

**Encoding:**

00	0100	dfff	ffff
----	------	------	------

**Description:** Inclusive OR the W register with register 'f'. If 'd' is 0 the result is placed in the W register. If 'd' is 1 the result is placed back in register 'f'.

**Words:** 1

**Cycles:** 1

**Example**

```

IORWF    RESULT, 0
  
```

**Before Instruction**  
RESULT = 0x13  
W = 0x91

**After Instruction**  
RESULT = 0x13  
W = 0x93  
Z = 1

## IORLW Inclusive OR Literal with W

**Syntax:** `[label] IORLW k`

**Operands:**  $0 \leq k \leq 255$

**Operation:**  $(W) .OR. k \rightarrow (W)$

**Status Affected:** Z

**Encoding:**

11	1000	kkkk	kkkk
----	------	------	------

**Description:** The contents of the W register is OR'ed with the eight bit literal 'k'. The result is placed in the W register.

**Words:** 1

**Cycles:** 1

**Example**

```

IORLW   0x35
  
```

**Before Instruction**  
W = 0x9A

**After Instruction**  
W = 0xBF  
Z = 1

## MOVLW Move Literal to W

**Syntax:** `[label] MOVLW k`

**Operands:**  $0 \leq k \leq 255$

**Operation:**  $k \rightarrow (W)$

**Status Affected:** None

**Encoding:**

11	00xx	kkkk	kkkk
----	------	------	------

**Description:** The eight bit literal 'k' is loaded into W register. The don't cares will assemble as 0's.

**Words:** 1

**Cycles:** 1

**Example**

```

MOVLW   0x5A
  
```

**After Instruction**  
W = 0x5A

<b>MOVWF</b>	<b>Move W to f</b>				
Syntax:	[ <i>label</i> ] MOVWF f				
Operands:	0 ≤ f ≤ 127 d ∈ [0,1]				
Operation:	(W) → (dest)				
Status Affected:	Z				
Encoding:	<table border="1"> <tr> <td>00</td> <td>1000</td> <td>dfff</td> <td>ffff</td> </tr> </table>	00	1000	dfff	ffff
00	1000	dfff	ffff		
Description:	The contents of register f is moved to a destination dependant upon the status of d. If d = 0, destination is W register. If d = 1, the destination is file register f itself. d = 1 is useful to test a file register since status flag Z is affected.				
Words:	1				
Cycles:	1				
Example	<pre>MOVWF FSR, 0</pre> <p>After Instruction</p> <p>W = value in FSR register Z = 1</p>				

<b>MOVWF</b>	<b>Move W to f</b>				
Syntax:	[ <i>label</i> ] MOVWF f				
Operands:	0 ≤ f ≤ 127				
Operation:	(W) → (f)				
Status Affected:	None				
Encoding:	<table border="1"> <tr> <td>00</td> <td>0000</td> <td>1fff</td> <td>ffff</td> </tr> </table>	00	0000	1fff	ffff
00	0000	1fff	ffff		
Description:	Move data from W register to register 'f'.				
Words:	1				
Cycles:	1				
Example	<pre>MOVWF OPTION</pre> <p>Before Instruction</p> <p>OPTION = 0xFF W = 0x4F</p> <p>After Instruction</p> <p>OPTION = 0x4F W = 0x4F</p>				

<b>NOP</b>	<b>No Operation</b>				
Syntax:	[ <i>label</i> ] NOP				
Operands:	None				
Operation:	No operation				
Status Affected:	None				
Encoding:	<table border="1"> <tr> <td>00</td> <td>0000</td> <td>0xx0</td> <td>0000</td> </tr> </table>	00	0000	0xx0	0000
00	0000	0xx0	0000		
Description:	No operation.				
Words:	1				
Cycles:	1				
Example	NOP				

<b>OPTION</b>	<b>Load Option Register</b>				
Syntax:	[ <i>label</i> ] OPTION				
Operands:	None				
Operation:	(W) → OPTION				
Status Affected:	None				
Encoding:	<table border="1"> <tr> <td>00</td> <td>0000</td> <td>0110</td> <td>0010</td> </tr> </table>	00	0000	0110	0010
00	0000	0110	0010		
Description:	The contents of the W register are loaded in the OPTION register. This instruction is supported for code compatibility with PIC16C5X products. Since OPTION is a readable/writable register, the user can directly address it.				
Words:	1				
Cycles:	1				
Example	<table border="1"> <tr> <td><b>To maintain upward compatibility with future PICmicro™ products, do not use this instruction.</b></td> </tr> </table>	<b>To maintain upward compatibility with future PICmicro™ products, do not use this instruction.</b>			
<b>To maintain upward compatibility with future PICmicro™ products, do not use this instruction.</b>					

# PIC16C55X

## RETFIE Return from Interrupt

Syntax: `[label] RETFIE`

Operands: None

Operation: TOS → PC,  
1 → GIE

Status Affected: None

Encoding: 

00	0000	0000	1001
----	------	------	------

Description: Return from Interrupt. Stack is POPed and Top of Stack (TOS) is loaded in the PC. Interrupts are enabled by setting Global Interrupt Enable bit, GIE (INTCON<7>). This is a two-cycle instruction.

Words: 1

Cycles: 2

Example `RETFIE`

After Interrupt

```
PC = TOS
GIE = 1
```

## RETURN Return from Subroutine

Syntax: `[label] RETURN`

Operands: None

Operation: TOS → PC

Status Affected: None

Encoding: 

00	0000	0000	1000
----	------	------	------

Description: Return from subroutine. The stack is POPed and the top of the stack (TOS) is loaded into the program counter. This is a two-cycle instruction.

Words: 1

Cycles: 2

Example `RETURN`

After Interrupt

```
PC = TOS
```

## RETLW Return with Literal in W

Syntax: `[label] RETLW k`

Operands:  $0 \leq k \leq 255$

Operation:  $k \rightarrow (W)$ ;  
TOS → PC

Status Affected: None

Encoding: 

11	01xx	kkkk	kkkk
----	------	------	------

Description: The W register is loaded with the eight bit literal 'k'. The program counter is loaded from the top of the stack (the return address). This is a two-cycle instruction.

Words: 1

Cycles: 2

Example

```
CALL TABLE;W contains table
;offset value
;W now has table
value
.
.
.
ADDWF PC ;W = offset
TABLE RETLW k1 ;Begin table
RETLW k2 ;
.
.
.
RETLW kn ; End of table
```

Before Instruction

```
W = 0x07
```

After Instruction

```
W = value of k8
```

## RLF Rotate Left f through Carry

Syntax: `[label] RLF f,d`

Operands:  $0 \leq f \leq 127$   
 $d \in [0,1]$

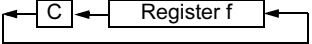
Operation: See description below

Status Affected: C

Encoding: 

00	1101	dfff	ffff
----	------	------	------

Description: The contents of register 'f' are rotated one bit to the left through the Carry Flag. If 'd' is 0 the result is placed in the W register. If 'd' is 1 the result is stored back in register 'f'.



Words: 1

Cycles: 1

Example `RLF REG1,0`

Before Instruction

```
REG1 = 1110 0110
C = 0
```

After Instruction

```
REG1 = 1110 0110
W = 1100 1100
C = 1
```

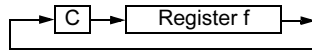


## RRF Rotate Right f through Carry

**Syntax:** [label] RRF f,d  
**Operands:**  $0 \leq f \leq 127$   
 $d \in [0,1]$   
**Operation:** See description below  
**Status Affected:** C  
**Encoding:**

00	1100	dfff	ffff
----	------	------	------

  
**Description:** The contents of register 'f' are rotated one bit to the right through the Carry Flag. If 'd' is 0 the result is placed in the W register. If 'd' is 1 the result is placed back in register 'f'.



**Words:** 1  
**Cycles:** 1  
**Example** RRF REG1,0

**Before Instruction**  
REG1 = 1110 0110  
C = 0  
**After Instruction**  
REG1 = 1110 0110  
W = 0111 0011  
C = 0

## SLEEP

**Syntax:** [label] SLEEP  
]  
**Operands:** None  
**Operation:** 00h → WDT,  
0 → WDT prescaler,  
1 →  $\overline{TO}$ ,  
0 →  $\overline{PD}$   
**Status Affected:**  $\overline{TO}$ ,  $\overline{PD}$   
**Encoding:**

00	0000	0110	0011
----	------	------	------

  
**Description:** The power-down status bit,  $\overline{PD}$  is cleared. Timeout status bit,  $\overline{TO}$  is set. Watchdog Timer and its prescaler are cleared. The processor is put into SLEEP mode with the oscillator stopped. See Section 6.8 for more details.

**Words:** 1  
**Cycles:** 1  
**Example:** SLEEP

## SUBLW Subtract W from Literal

**Syntax:** [label] SUBLW k  
**Operands:**  $0 \leq k \leq 255$   
**Operation:**  $k - (W) \rightarrow (W)$   
**Status Affected:** C, DC, Z  
**Encoding:**

11	110x	kkkk	kkkk
----	------	------	------

  
**Description:** The W register is subtracted (2's complement method) from the eight bit literal 'k'. The result is placed in the W register.

**Words:** 1  
**Cycles:** 1

**Example 1:** SUBLW 0x02  
**Before Instruction**  
W = 1  
C = ?  
**After Instruction**  
W = 1  
C = 1; result is positive

**Example 2:** **Before Instruction**  
W = 2  
C = ?  
**After Instruction**  
W = 0  
C = 1; result is zero

**Example 3:** **Before Instruction**  
W = 3  
C = ?  
**After Instruction**  
W = 0xFF  
C = 0; result is negative

# PIC16C55X

## SUBWF Subtract W from f

Syntax: [ *label* ] SUBWF f,d

Operands:  $0 \leq f \leq 127$   
 $d \in [0,1]$

Operation:  $(f) - (W) \rightarrow (\text{dest})$

Status Affected: C, DC, Z

Encoding:

00	0010	dfff	ffff
----	------	------	------

Description: Subtract (2's complement method) W register from register 'f'. If 'd' is 0 the result is stored in the W register. If 'd' is 1 the result is stored back in register 'f'.

Words: 1

Cycles: 1

Example 1: SUBWF REG1,1

Before Instruction

REG1 = 3  
W = 2  
C = ?

After Instruction

REG1 = 1  
W = 2  
C = 1; result is positive

Example 2: Before Instruction

REG1 = 2  
W = 2  
C = ?

After Instruction

REG1 = 0  
W = 2  
C = 1; result is zero

Example 3: Before Instruction

REG1 = 1  
W = 2  
C = ?

After Instruction

REG1 = 0xFF  
W = 2  
C = 0; result is negative

## SWAPF Swap Nibbles in f

Syntax: [ *label* ] SWAPF f,d

Operands:  $0 \leq f \leq 127$   
 $d \in [0,1]$

Operation:  $(f<3:0>) \rightarrow (\text{dest}<7:4>)$ ,  
 $(f<7:4>) \rightarrow (\text{dest}<3:0>)$

Status Affected: None

Encoding:

00	1110	dfff	ffff
----	------	------	------

Description: The upper and lower nibbles of register 'f' are exchanged. If 'd' is 0 the result is placed in W register. If 'd' is 1 the result is placed in register 'f'.

Words: 1

Cycles: 1

Example SWAPF REG, 0

Before Instruction

REG1 = 0xA5

After Instruction

REG1 = 0xA5  
W = 0x5A

TRIS	Load TRIS Register				
Syntax:	[ <i>label</i> ] TRIS f				
Operands:	$5 \leq f \leq 7$				
Operation:	$(W) \rightarrow \text{TRIS register } f$ ;				
Status Affected:	None				
Encoding:	<table border="1"> <tr> <td>00</td> <td>0000</td> <td>0110</td> <td>0fff</td> </tr> </table>	00	0000	0110	0fff
00	0000	0110	0fff		
Description:	The instruction is supported for code compatibility with the PIC16C5X products. Since TRIS registers are readable and writable, the user can directly address them.				
Words:	1				
Cycles:	1				
Example	<table border="1"> <tr> <td><b>To maintain upward compatibility with future PICmicro™ products, do not use this instruction.</b></td> </tr> </table>	<b>To maintain upward compatibility with future PICmicro™ products, do not use this instruction.</b>			
<b>To maintain upward compatibility with future PICmicro™ products, do not use this instruction.</b>					

## **XORLW** Exclusive OR Literal with W

Syntax: `[label] XORLW k`  
 Operands:  $0 \leq k \leq 255$   
 Operation:  $(W) .XOR. k \rightarrow (W)$   
 Status Affected: Z  
 Encoding: 

11	1010	kkkk	kkkk
----	------	------	------

  
 Description: The contents of the W register are XOR'ed with the eight bit literal 'k'. The result is placed in the W register.  
 Words: 1  
 Cycles: 1  
 Example: `XORLW 0xAF`

### Before Instruction

`W = 0xB5`

### After Instruction

`W = 0x1A`

## **XORWF** Exclusive OR W with f

Syntax: `[label] XORWF f,d`  
 Operands:  $0 \leq f \leq 127$   
 $d \in [0,1]$   
 Operation:  $(W) .XOR. (f) \rightarrow (dest)$   
 Status Affected: Z  
 Encoding: 

00	0110	dfff	ffff
----	------	------	------

  
 Description: Exclusive OR the contents of the W register with register 'f'. If 'd' is 0 the result is stored in the W register. If 'd' is 1 the result is stored back in register 'f'.  
 Words: 1  
 Cycles: 1  
 Example: `XORWF REG 1`

### Before Instruction

`REG = 0xAF`

`W = 0xB5`

### After Instruction

`REG = 0x1A`

`W = 0xB5`

# PIC16C55X

---

NOTES:

## 9.0 DEVELOPMENT SUPPORT

The PICmicro<sup>®</sup> microcontrollers are supported with a full range of hardware and software development tools:

- Integrated Development Environment
  - MPLAB<sup>®</sup> IDE Software
- Assemblers/Compilers/Linkers
  - MPASM<sup>™</sup> Assembler
  - MPLAB C17 and MPLAB C18 C Compilers
  - MPLINK<sup>™</sup> Object Linker/  
MPLIB<sup>™</sup> Object Librarian
- Simulators
  - MPLAB SIM Software Simulator
- Emulators
  - MPLAB ICE 2000 In-Circuit Emulator
  - ICEPIC<sup>™</sup> In-Circuit Emulator
- In-Circuit Debugger
  - MPLAB ICD
- Device Programmers
  - PRO MATE<sup>®</sup> II Universal Device Programmer
  - PICSTART<sup>®</sup> Plus Entry-Level Development Programmer
- Low Cost Demonstration Boards
  - PICDEM<sup>™</sup> 1 Demonstration Board
  - PICDEM 2 Demonstration Board
  - PICDEM 3 Demonstration Board
  - PICDEM 17 Demonstration Board
  - KEELOQ<sup>®</sup> Demonstration Board

### 9.1 MPLAB Integrated Development Environment Software

The MPLAB IDE software brings an ease of software development previously unseen in the 8-bit microcontroller market. The MPLAB IDE is a Windows<sup>®</sup>-based application that contains:

- An interface to debugging tools
  - simulator
  - programmer (sold separately)
  - emulator (sold separately)
  - in-circuit debugger (sold separately)
- A full-featured editor
- A project manager
- Customizable toolbar and key mapping
- A status bar
- On-line help

The MPLAB IDE allows you to:

- Edit your source files (either assembly or 'C')
- One touch assemble (or compile) and download to PICmicro emulator and simulator tools (automatically updates all project information)
- Debug using:
  - source files
  - absolute listing file
  - machine code

The ability to use MPLAB IDE with multiple debugging tools allows users to easily switch from the cost-effective simulator to a full-featured emulator with minimal retraining.

### 9.2 MPASM Assembler

The MPASM assembler is a full-featured universal macro assembler for all PICmicro MCU's.

The MPASM assembler has a command line interface and a Windows shell. It can be used as a stand-alone application on a Windows 3.x or greater system, or it can be used through MPLAB IDE. The MPASM assembler generates relocatable object files for the MPLINK object linker, Intel<sup>®</sup> standard HEX files, MAP files to detail memory usage and symbol reference, an absolute LST file that contains source lines and generated machine code, and a COD file for debugging.

The MPASM assembler features include:

- Integration into MPLAB IDE projects.
- User-defined macros to streamline assembly code.
- Conditional assembly for multi-purpose source files.
- Directives that allow complete control over the assembly process.

### 9.3 MPLAB C17 and MPLAB C18 C Compilers

The MPLAB C17 and MPLAB C18 Code Development Systems are complete ANSI 'C' compilers for Microchip's PIC17CXXX and PIC18CXXX family of microcontrollers, respectively. These compilers provide powerful integration capabilities and ease of use not found with other compilers.

For easier source level debugging, the compilers provide symbol information that is compatible with the MPLAB IDE memory display.

## 9.4 MPLINK Object Linker/ MPLIB Object Librarian

The MPLINK object linker combines relocatable objects created by the MPASM assembler and the MPLAB C17 and MPLAB C18 C compilers. It can also link relocatable objects from pre-compiled libraries, using directives from a linker script.

The MPLIB object librarian is a librarian for pre-compiled code to be used with the MPLINK object linker. When a routine from a library is called from another source file, only the modules that contain that routine will be linked in with the application. This allows large libraries to be used efficiently in many different applications. The MPLIB object librarian manages the creation and modification of library files.

The MPLINK object linker features include:

- Integration with MPASM assembler and MPLAB C17 and MPLAB C18 C compilers.
- Allows all memory areas to be defined as sections to provide link-time flexibility.

The MPLIB object librarian features include:

- Easier linking because single libraries can be included instead of many smaller files.
- Helps keep code maintainable by grouping related modules together.
- Allows libraries to be created and modules to be added, listed, replaced, deleted or extracted.

## 9.5 MPLAB SIM Software Simulator

The MPLAB SIM software simulator allows code development in a PC-hosted environment by simulating the PICmicro series microcontrollers on an instruction level. On any given instruction, the data areas can be examined or modified and stimuli can be applied from a file, or user-defined key press, to any of the pins. The execution can be performed in single step, execute until break, or Trace mode.

The MPLAB SIM simulator fully supports symbolic debugging using the MPLAB C17 and the MPLAB C18 C compilers and the MPASM assembler. The software simulator offers the flexibility to develop and debug code outside of the laboratory environment, making it an excellent multi-project software development tool.

## 9.6 MPLAB ICE High Performance Universal In-Circuit Emulator with MPLAB IDE

The MPLAB ICE universal in-circuit emulator is intended to provide the product development engineer with a complete microcontroller design tool set for PICmicro microcontrollers (MCUs). Software control of the MPLAB ICE in-circuit emulator is provided by the MPLAB Integrated Development Environment (IDE), which allows editing, building, downloading and source debugging from a single environment.

The MPLAB ICE 2000 is a full-featured emulator system with enhanced trace, trigger and data monitoring features. Interchangeable processor modules allow the system to be easily re configured for emulation of different processors. The universal architecture of the MPLAB ICE in-circuit emulator allows expansion to support new PICmicro microcontrollers.

The MPLAB ICE in-circuit emulator system has been designed as a real-time emulation system, with advanced features that are generally found on more expensive development tools. The PC platform and Microsoft® Windows environment were chosen to best make these features available to you, the end user.

## 9.7 ICEPIC In-Circuit Emulator

The ICEPIC low cost, in-circuit emulator is a solution for the Microchip Technology PIC16C5X, PIC16C6X, PIC16C7X and PIC16CXXX families of 8-bit One-Time-Programmable (OTP) microcontrollers. The modular system can support different subsets of PIC16C5X or PIC16CXXX products through the use of interchangeable personality modules, or daughter boards. The emulator is capable of emulating without target application circuitry being present.

## 9.8 MPLAB ICD In-Circuit Debugger

Microchip's In-Circuit Debugger, MPLAB ICD, is a powerful, low cost, run-time development tool. This tool is based on the FLASH PICmicro MCUs and can be used to develop for this and other PICmicro microcontrollers. The MPLAB ICD utilizes the in-circuit debugging capability built into the FLASH devices. This feature, along with Microchip's In-Circuit Serial Programming™ protocol, offers cost-effective in-circuit FLASH debugging from the graphical user interface of the MPLAB Integrated Development Environment. This enables a designer to develop and debug source code by watching variables, single-stepping and setting break points. Running at full speed enables testing hardware in real-time.

## 9.9 PRO MATE II Universal Device Programmer

The PRO MATE II universal device programmer is a full-featured programmer, capable of operating in Stand-alone mode, as well as PC-hosted mode. The PRO MATE II device programmer is CE compliant.

The PRO MATE II device programmer has programmable VDD and VPP supplies, which allow it to verify programmed memory at VDD min and VDD max for maximum reliability. It has an LCD display for instructions and error messages, keys to enter commands and a modular detachable socket assembly to support various package types. In Stand-alone mode, the PRO MATE II device programmer can read, verify, or program PICmicro devices. It can also set code protection in this mode.

## 9.10 PICSTART Plus Entry Level Development Programmer

The PICSTART Plus development programmer is an easy-to-use, low cost, prototype programmer. It connects to the PC via a COM (RS-232) port. MPLAB Integrated Development Environment software makes using the programmer simple and efficient.

The PICSTART Plus development programmer supports all PICmicro devices with up to 40 pins. Larger pin count devices, such as the PIC16C92X and PIC17C76X, may be supported with an adapter socket. The PICSTART Plus development programmer is CE compliant.

## 9.11 PICDEM 1 Low Cost PICmicro Demonstration Board

The PICDEM 1 demonstration board is a simple board which demonstrates the capabilities of several of Microchip's microcontrollers. The microcontrollers supported are: PIC16C5X (PIC16C54 to PIC16C58A), PIC16C61, PIC16C62X, PIC16C71, PIC16C8X, PIC17C42, PIC17C43 and PIC17C44. All necessary hardware and software is included to run basic demo programs. The user can program the sample microcontrollers provided with the PICDEM 1 demonstration board on a PRO MATE II device programmer, or a PICSTART Plus development programmer, and easily test firmware. The user can also connect the PICDEM 1 demonstration board to the MPLAB ICE in-circuit emulator and download the firmware to the emulator for testing. A prototype area is available for the user to build some additional hardware and connect it to the microcontroller socket(s). Some of the features include an RS-232 interface, a potentiometer for simulated analog input, push button switches and eight LEDs connected to PORTB.

## 9.12 PICDEM 2 Low Cost PIC16CXX Demonstration Board

The PICDEM 2 demonstration board is a simple demonstration board that supports the PIC16C62, PIC16C64, PIC16C65, PIC16C73 and PIC16C74 microcontrollers. All the necessary hardware and software is included to run the basic demonstration programs. The user can program the sample microcontrollers provided with the PICDEM 2 demonstration board on a PRO MATE II device programmer, or a PICSTART Plus development programmer, and easily test firmware. The MPLAB ICE in-circuit emulator may also be used with the PICDEM 2 demonstration board to test firmware. A prototype area has been provided to the user for adding additional hardware and connecting it to the microcontroller socket(s). Some of the features include a RS-232 interface, push button switches, a potentiometer for simulated analog input, a serial EEPROM to demonstrate usage of the I<sup>2</sup>C™ bus and separate headers for connection to an LCD module and a keypad.

# PIC16C55X

---

## 9.13 PICDEM 3 Low Cost PIC16CXXX Demonstration Board

The PICDEM 3 demonstration board is a simple demonstration board that supports the PIC16C923 and PIC16C924 in the PLCC package. It will also support future 44-pin PLCC microcontrollers with an LCD Module. All the necessary hardware and software is included to run the basic demonstration programs. The user can program the sample microcontrollers provided with the PICDEM 3 demonstration board on a PRO MATE II device programmer, or a PICSTART Plus development programmer with an adapter socket, and easily test firmware. The MPLAB ICE in-circuit emulator may also be used with the PICDEM 3 demonstration board to test firmware. A prototype area has been provided to the user for adding hardware and connecting it to the microcontroller socket(s). Some of the features include a RS-232 interface, push button switches, a potentiometer for simulated analog input, a thermistor and separate headers for connection to an external LCD module and a keypad. Also provided on the PICDEM 3 demonstration board is a LCD panel, with 4 commons and 12 segments, that is capable of displaying time, temperature and day of the week. The PICDEM 3 demonstration board provides an additional RS-232 interface and Windows software for showing the demultiplexed LCD signals on a PC. A simple serial interface allows the user to construct a hardware demultiplexer for the LCD signals.

## 9.14 PICDEM 17 Demonstration Board

The PICDEM 17 demonstration board is an evaluation board that demonstrates the capabilities of several Microchip microcontrollers, including PIC17C752, PIC17C756A, PIC17C762 and PIC17C766. All necessary hardware is included to run basic demo programs, which are supplied on a 3.5-inch disk. A programmed sample is included and the user may erase it and program it with the other sample programs using the PRO MATE II device programmer, or the PICSTART Plus development programmer, and easily debug and test the sample code. In addition, the PICDEM 17 demonstration board supports downloading of programs to and executing out of external FLASH memory on board. The PICDEM 17 demonstration board is also usable with the MPLAB ICE in-circuit emulator, or the PICMASTER emulator and all of the sample programs can be run and modified using either emulator. Additionally, a generous prototype area is available for user hardware.

## 9.15 KEELOQ Evaluation and Programming Tools

KEELOQ evaluation and programming tools support Microchip's HCS Secure Data Products. The HCS evaluation kit includes a LCD display to show changing codes, a decoder to decode transmissions and a programming interface to program test transmitters.



**TABLE 9-1: DEVELOPMENT TOOLS FROM MICROCHIP**

Tool	PIC12CXXX	PIC14000	PIC16C5X	PIC16C6X	PIC16CXX	PIC16C7X	PIC16C7XX	PIC16C8X	PIC16F8XX	PIC16G9XX	PIC17C4X	PIC17C7XX	PIC18CXX2	PIC18FXX	24CXX/ 25CXX/ 93CXX	HC5XX	MCRFXXX	MCP2510
<b>Software Tools</b>																		
MPLAB® Integrated Development Environment	✓	✓	✓	✓	✓	✓	✓	✓	✓	✓	✓	✓	✓	✓	✓	✓	✓	✓
MPLAB® C17 C Compiler																		
MPLAB® C18 C Compiler																		
MPASM™ Assembler/ MPLINK™ Object Linker	✓	✓	✓	✓	✓	✓	✓	✓	✓	✓	✓	✓	✓	✓	✓	✓	✓	✓
MPLAB® ICE In-Circuit Emulator	✓	✓	✓	✓	✓	✓	✓	✓	✓	✓	✓	✓	✓	✓	✓	✓	✓	✓
ICEPIC™ In-Circuit Emulator	✓		✓	✓	✓	✓	✓	✓	✓	✓	✓	✓	✓	✓	✓	✓	✓	✓
<b>Debugger</b>																		
MPLAB® ICD In-Circuit Debugger				✓*			✓*		✓					✓				
<b>Programmers</b>																		
PICSTART® Plus Entry Level Development Programmer	✓	✓	✓	✓	✓	✓	✓	✓	✓	✓	✓	✓	✓	✓	✓	✓	✓	✓
PRO MATE® II Universal Device Programmer	✓	✓	✓	✓	✓	✓	✓	✓	✓	✓	✓	✓	✓	✓	✓	✓	✓	✓
<b>Demo Boards and Eval Kits</b>																		
PICDEM™ 1 Demonstration Board			✓								✓							
PICDEM™ 2 Demonstration Board				✓†									✓					
PICDEM™ 3 Demonstration Board										✓								
PICDEM™ 14A Demonstration Board		✓																
PICDEM™ 17 Demonstration Board											✓							
KEELOQ® Evaluation Kit																✓		
KEELOQ® Transponder Kit																✓		
microID™ Programmer's Kit																	✓	
125 kHz microID™ Developer's Kit																	✓	
125 kHz Anticollision microID™ Developer's Kit																	✓	
13.56 MHz Anticollision microID™ Developer's Kit																	✓	
MCP2510 CAN Developer's Kit																	✓	✓

\* Contact the Microchip Technology Inc. web site at [www.microchip.com](http://www.microchip.com) for information on how to use the MPLAB® ICD In-Circuit Debugger (DV164001) with PIC16C62, 63, 64, 65, 72, 73, 74, 76, 77.

\*\* Contact Microchip Technology Inc. for availability date.

# PIC16C55X

---

---

NOTES:

## 10.0 ELECTRICAL SPECIFICATIONS

### Absolute Maximum Ratings †

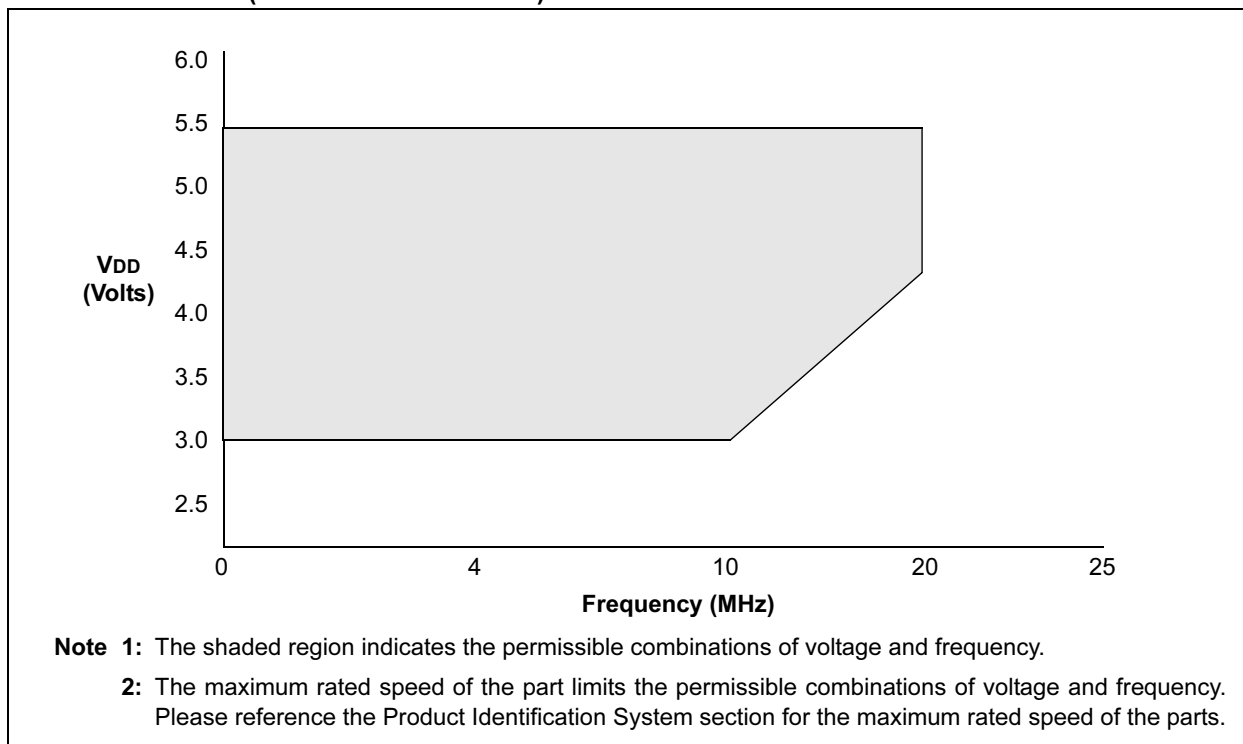
Ambient Temperature under bias .....	-40° to +125°C
Storage Temperature .....	-65° to +150°C
Voltage on any pin with respect to VSS (except VDD and $\overline{\text{MCLR}}$ ) .....	-0.6V to VDD +0.6V
Voltage on VDD with respect to VSS .....	0 to +7.5V
Voltage on $\overline{\text{MCLR}}$ with respect to VSS.....	0 to +14V
Total power Dissipation ( <b>Note 1</b> ).....	1.0W
Maximum Current out of VSS pin .....	300 mA
Maximum Current into VDD pin .....	250 mA
Input Clamp Current, I <sub>IK</sub> (V <sub>I</sub> < 0 or V <sub>I</sub> > VDD) .....	±20 mA
Output Clamp Current, I <sub>OK</sub> (V <sub>O</sub> < 0 or V <sub>O</sub> > VDD).....	±20 mA
Maximum Output Current sunk by any I/O pin.....	25 mA
Maximum Output Current sourced by any I/O pin.....	25 mA
Maximum Current sunk by PORTA, PORTB and PORTC .....	200 mA
Maximum Current sourced by PORTA, PORTB and PORTC .....	200 mA

**Note 1:** Power dissipation is calculated as follows:  $P_{\text{Dis}} = V_{\text{DD}} \times \{I_{\text{DD}} - \sum I_{\text{OH}}\} + \sum \{(V_{\text{DD}} - V_{\text{OH}}) \times I_{\text{OH}}\} + \sum (V_{\text{OL}} \times I_{\text{OL}})$

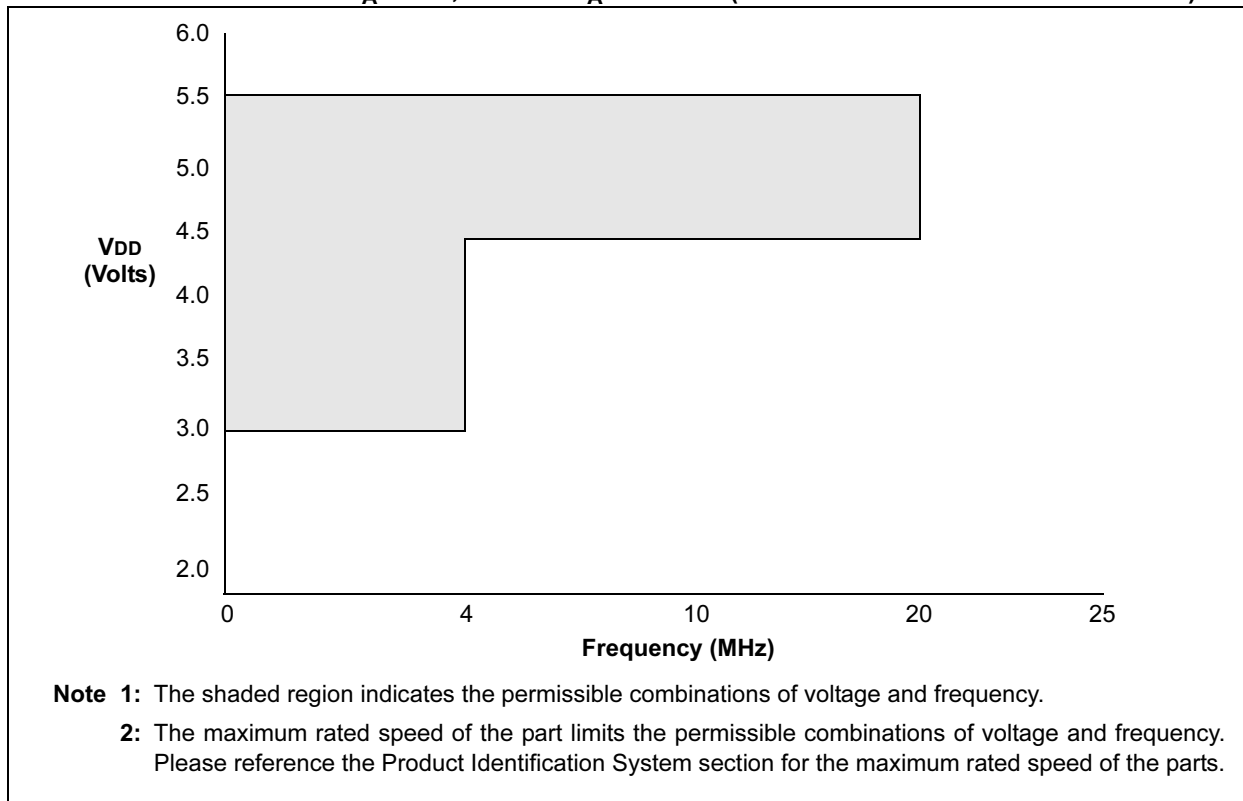
† **NOTICE:** Stresses above those listed under “Absolute Maximum Ratings” may cause permanent damage to the device. This is a stress rating only and functional operation of the device at those or any other conditions above those indicated in the operation listings of this specification is not implied. Exposure to maximum rating conditions for extended periods may affect device reliability.

# PIC16C55X

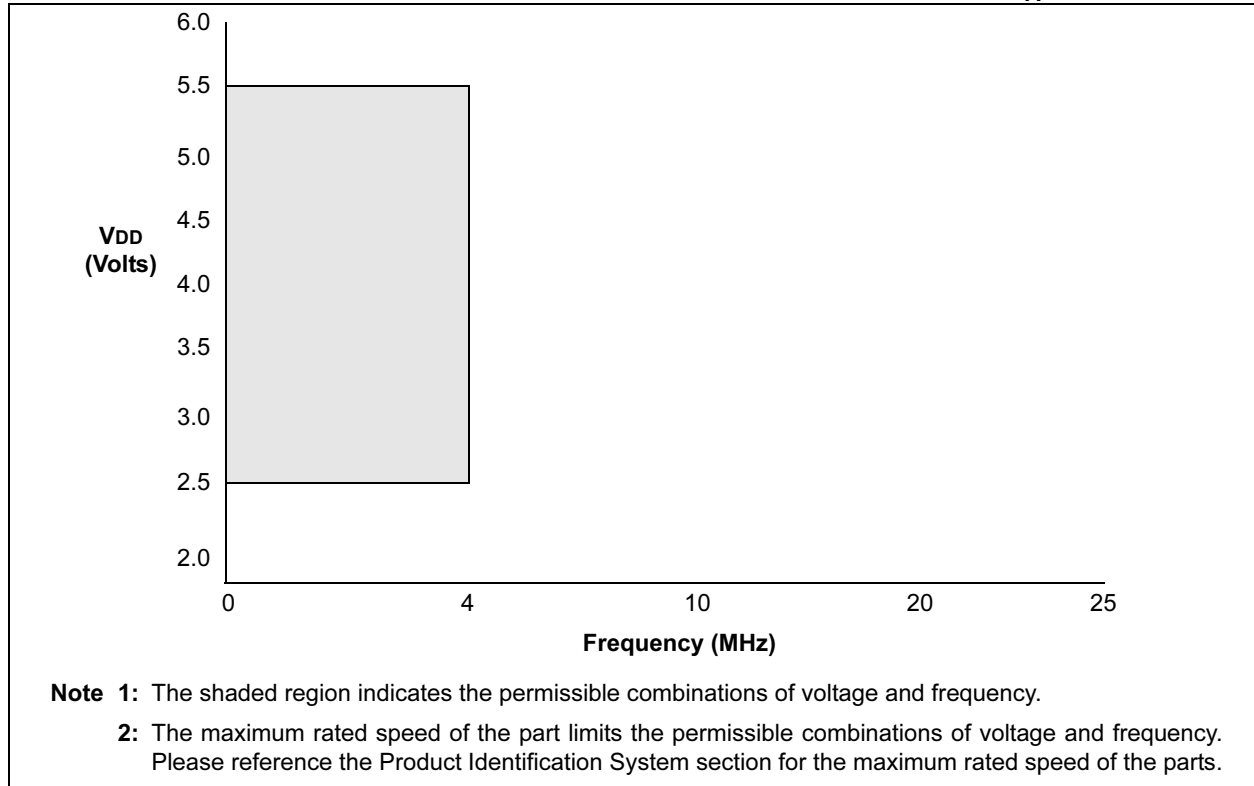
**FIGURE 10-1: PIC16LC554/557/558 VOLTAGE-FREQUENCY GRAPH,  $0^{\circ}\text{C} \leq T_A \leq +70^{\circ}\text{C}$  (COMMERCIAL TEMPS)**



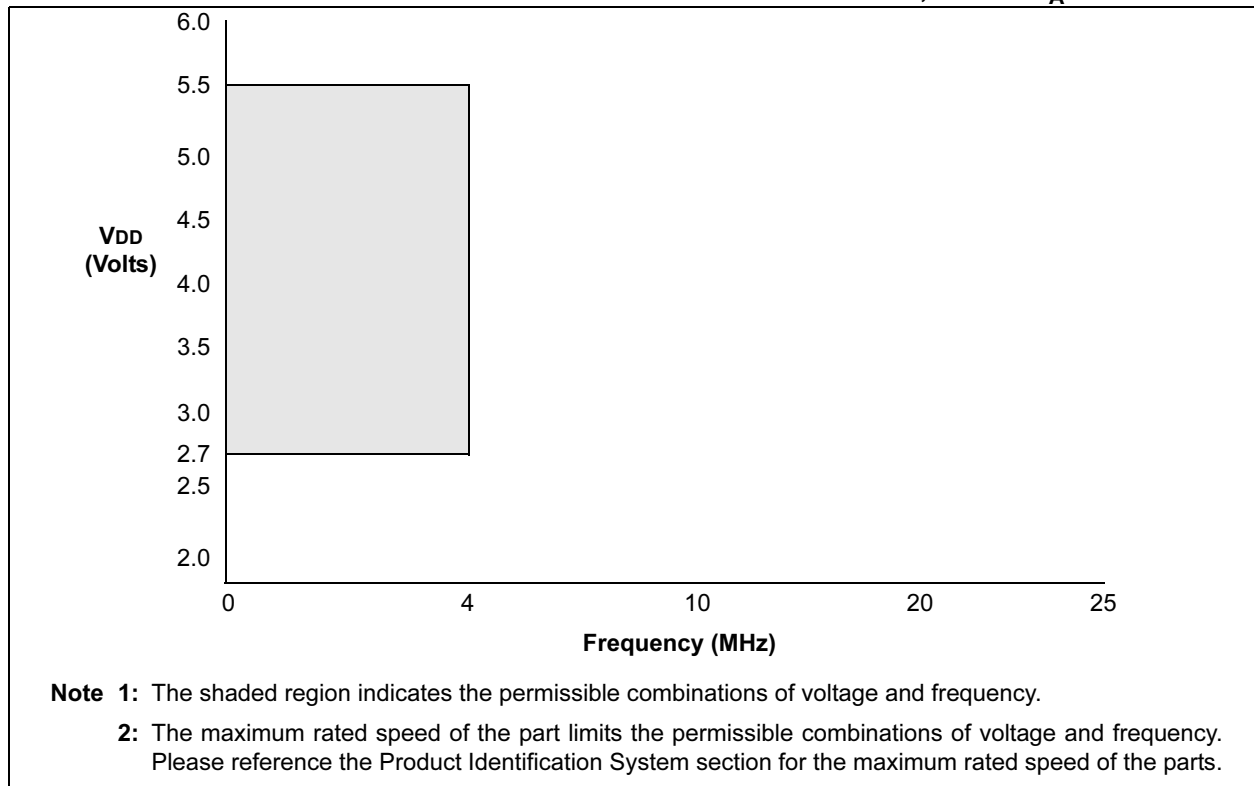
**FIGURE 10-2: PIC16LC554/557/558 VOLTAGE-FREQUENCY GRAPH,  $-40^{\circ}\text{C} \leq T_A < 0^{\circ}\text{C}$ ,  $+70^{\circ}\text{C} < T_A \leq +125^{\circ}\text{C}$  (OUTSIDE OF COMMERCIAL TEMPS)**



**FIGURE 10-3: PIC16LC554/557/558 VOLTAGE-FREQUENCY GRAPH,  $0^{\circ}\text{C} \leq T_A \leq +85^{\circ}\text{C}$**



**FIGURE 10-4: PIC16LC554/557/558 VOLTAGE-FREQUENCY GRAPH,  $-40^{\circ}\text{C} \leq T_A \leq 0^{\circ}\text{C}$**



# PIC16C55X

## 10.1 DC Characteristics: PIC16C55X-04 (Commercial, Industrial, Extended) PIC16C55X-20 (Commercial, Industrial, Extended) PIC16LC55X-04(Commercial, Industrial, Extended)

Standard Operating Conditions (unless otherwise stated) Operating temperature $-40^{\circ}\text{C} \leq T_A \leq +85^{\circ}\text{C}$ for industrial and $0^{\circ}\text{C} \leq T_A \leq +70^{\circ}\text{C}$ for commercial and $-40^{\circ}\text{C} \leq T_A \leq +125^{\circ}\text{C}$ for extended							
DC Characteristics							
Param No.	Sym	Characteristic	Min	Typ†	Max	Units	Conditions
D001	VDD	<b>Supply Voltage</b>					
		16LC55X	3.0 2.5	—	5.5 5.5	V	XT and RC osc configuration LP osc configuration
D001 D001A		16C55X	3.0 4.5	— —	5.5 5.5	V V	XT, RC and LP osc configuration HS osc configuration
D002	VDR	<b>RAM Data Retention Voltage<sup>(1)</sup></b>	—	1.5*	—	V	Device in SLEEP mode
D003	VPOR	<b>VDD Start Voltage</b> to ensure Power-on Reset	—	VSS	—	V	See Section 6.4, Power-on Reset for details
D004	SVDD	<b>VDD Rise Rate</b> to ensure Power-on Reset	0.05*	—	—	V/ms	See Section 6.4, Power-on Reset for details
D010 D010A D010 D010A D013	IDD	<b>Supply Current<sup>(2)</sup></b>					
		16LC55X	—	1.4	2.5	mA	XT and RC osc configuration Fosc = 2.0 MHz, VDD = 3.0V, WDT disabled <sup>(4)</sup>
			—	26	53	μA	LP osc configuration Fosc = 32 kHz, VDD = 3.0V, WDT disabled
		16C55X	—	1.8	3.3	mA	XT and RC osc configuration Fosc = 4 MHz, VDD = 5.5V, WDT disabled <sup>(4)</sup>
			—	35	70	μA	LP osc configuration, PIC16C55X-04 only Fosc = 32 kHz, VDD = 4.0V, WDT disabled
			—	9.0	20	mA	HS osc configuration Fosc = 20 MHz, VDD = 5.5V, WDT disabled

\* These parameters are characterized but not tested.

† Data in "Typ" column is at 5V, 25°C, unless otherwise stated. These parameters are for design guidance only and are not tested.

- Note 1:** This is the limit to which VDD can be lowered in SLEEP mode without losing RAM data.
- Note 2:** The supply current is mainly a function of the operating voltage and frequency. Other factors such as I/O pin loading and switching rate, oscillator type, internal code execution pattern, and temperature also have an impact on the current consumption.  
The test conditions for all IDD measurements in active Operation mode are:  
OSC1 = external square wave, from rail to rail; all I/O pins configured as input, pulled to VDD,  
MCLR = VDD; WDT enabled/disabled as specified.
- Note 3:** The power-down current in SLEEP mode does not depend on the oscillator type. Power-down current is measured with the part in SLEEP mode, with all I/O pins configured as input and tied to VDD or VSS.
- Note 4:** For RC osc configuration, current through REXT is not included. The current through the resistor can be estimated by the formula  $I_r = V_{DD}/2R_{EXT}$  (mA) with REXT in kΩ.
- Note 5:** The Δ current is the additional current consumed when this peripheral is enabled. This current should be added to the base IDD or IPD measurement.

## 10.1 DC Characteristics: PIC16C55X-04 (Commercial, Industrial, Extended) PIC16C55X-20 (Commercial, Industrial, Extended) PIC16LC55X-04(Commercial, Industrial, Extended)

DC Characteristics		Standard Operating Conditions (unless otherwise stated) Operating temperature $-40^{\circ}\text{C} \leq T_A \leq +85^{\circ}\text{C}$ for industrial and $0^{\circ}\text{C} \leq T_A \leq +70^{\circ}\text{C}$ for commercial and $-40^{\circ}\text{C} \leq T_A \leq +125^{\circ}\text{C}$ for extended					
Param No.	Sym	Characteristic	Min	Typ†	Max	Units	Conditions
D020	IPD	<b>Power-Down Current<sup>(3)</sup></b>					
		16LC55X	—	0.7	2	$\mu\text{A}$	$V_{DD} = 3.0\text{V}$ , WDT disabled
		16C55X	—	1.0	2.5 15	$\mu\text{A}$ $\mu\text{A}$	$V_{DD} = 4.0\text{V}$ , WDT disabled (+85°C to +125°C)
	$\Delta I_{WDT}$	<b>WDT Current<sup>(5)</sup></b>					
		16LC55X	—	6.0	15	$\mu\text{A}$	$V_{DD} = 3.0\text{V}$
		16C55X	—	6.0	20	$\mu\text{A}$	$V_{DD} = 4.0\text{V}$ (+85°C to +125°C)

\* These parameters are characterized but not tested.

† Data in "Typ" column is at 5V, 25°C, unless otherwise stated. These parameters are for design guidance only and are not tested.

**Note 1:** This is the limit to which  $V_{DD}$  can be lowered in SLEEP mode without losing RAM data.

**2:** The supply current is mainly a function of the operating voltage and frequency. Other factors such as I/O pin loading and switching rate, oscillator type, internal code execution pattern, and temperature also have an impact on the current consumption.

The test conditions for all  $I_{DD}$  measurements in active Operation mode are:

$OSC1$  = external square wave, from rail to rail; all I/O pins configured as input, pulled to  $V_{DD}$ ,

$MCLR = V_{DD}$ ; WDT enabled/disabled as specified.

**3:** The power-down current in SLEEP mode does not depend on the oscillator type. Power-down current is measured with the part in SLEEP mode, with all I/O pins configured as input and tied to  $V_{DD}$  or  $V_{SS}$ .

**4:** For RC osc configuration, current through  $R_{EXT}$  is not included. The current through the resistor can be estimated by the formula  $I_r = V_{DD}/2R_{EXT}$  (mA) with  $R_{EXT}$  in  $k\Omega$ .

**5:** The  $\Delta$  current is the additional current consumed when this peripheral is enabled. This current should be added to the base  $I_{DD}$  or  $I_{PD}$  measurement.

# PIC16C55X

## 10.2 DC Characteristics: PIC16C55X (Commercial, Industrial, Extended) PIC16LC55X(Commercial, Industrial, Extended)

Standard Operating Conditions (unless otherwise stated)							
DC Characteristics							
Operating temperature $-40^{\circ}\text{C} \leq \text{TA} \leq +85^{\circ}\text{C}$ for industrial and $0^{\circ}\text{C} \leq \text{TA} \leq +70^{\circ}\text{C}$ for commercial and $-40^{\circ}\text{C} \leq \text{TA} \leq +125^{\circ}\text{C}$ for automotive							
Operating voltage $V_{DD}$ range as described in DC spec Table 10-1							
Param. No.	Sym	Characteristic	Min	Typ†	Max	Unit	Conditions
	$V_{IL}$	<b>Input Low Voltage</b>					
D030		I/O ports with TTL buffer	$V_{SS}$	—	0.8V $0.15 V_{DD}$	V	$V_{DD} = 4.5\text{V to } 5.5\text{V}$ otherwise
D031		with Schmitt Trigger input	$V_{SS}$	—	$0.2 V_{DD}$	V	<b>(Note1)</b>
D032		$\overline{\text{MCLR}}$ , RA4/T0CKI, OSC1 (in RC mode)	$V_{SS}$	—	$0.2 V_{DD}$	V	
D033		OSC1 (in XT* and HS) OSC1 (in LP*)	$V_{SS}$ $V_{SS}$	— —	$0.3 V_{DD}$ $0.6 V_{DD}-1.0$	V V	
	$V_{IH}$	<b>Input High Voltage</b>					
D040		I/O ports with TTL buffer	2.0V $0.8 + 0.25 V_{DD}$	— —	$V_{DD}$ $V_{DD}$	V V	$V_{DD} = 4.5\text{V to } 5.5\text{V}$ otherwise
D041		with Schmitt Trigger input	0.8V	—	$V_{DD}$	V	<b>(Note1)</b>
D042		$\overline{\text{MCLR}}$ RA4/T0CKI	$0.8 V_{DD}$	—	$V_{DD}$	V	
D043		OSC1 (XT*, HS and LP*)	$0.7 V_{DD}$	—	$V_{DD}$	V	
D043A		OSC1 (in RC mode)	$0.9 V_{DD}$	—			
D070	IPURB	PORTB weak pull-up current	50	200	400	$\mu\text{A}$	$V_{DD} = 5.0\text{V}$ , $V_{PIN} = V_{SS}$
	$I_{IL}$	<b>Input Leakage Current<sup>(2)(3)</sup></b>					
D060		I/O ports (Except PORTA)	—	—	$\pm 1.0$	$\mu\text{A}$	$V_{SS} \leq V_{PIN} \leq V_{DD}$ , pin at hi-impedance
D061		PORTA	—	—	$\pm 0.5$	$\mu\text{A}$	$V_{SS} \leq V_{PIN} \leq V_{DD}$ , pin at hi-impedance
D063		RA4/T0CKI	—	—	$\pm 1.0$	$\mu\text{A}$	$V_{SS} \leq V_{PIN} \leq V_{DD}$
		OSC1, $\overline{\text{MCLR}}$	—	—	$\pm 5.0$	$\mu\text{A}$	$V_{SS} \leq V_{PIN} \leq V_{DD}$ , XT, HS and LP osc configuration
	$V_{OL}$	<b>Output Low Voltage</b>					
D080		I/O ports	—	—	0.6	V	$I_{OL}=8.5\text{ mA}$ , $V_{DD}=4.5\text{V}$ , $-40^{\circ}$ to $+85^{\circ}\text{C}$
D083		OSC2/CLKOUT (RC only)	— —	— —	0.6 0.6	V V	$I_{OL}=7.0\text{ mA}$ , $V_{DD}=4.5\text{V}$ , $+125^{\circ}\text{C}$ $I_{OL}=1.6\text{ mA}$ , $V_{DD}=4.5\text{V}$ , $-40^{\circ}$ to $+85^{\circ}\text{C}$ $I_{OL}=1.2\text{ mA}$ , $V_{DD}=4.5\text{V}$ , $+125^{\circ}\text{C}$
	$V_{OH}$	<b>Output High Voltage<sup>(3)</sup></b>					
D090		I/O ports (Except RA4)	$V_{DD}-0.7$	—	—	V	$I_{OH}=-3.0\text{ mA}$ , $V_{DD}=4.5\text{V}$ , $-40^{\circ}$ to $+85^{\circ}\text{C}$

\* These parameters are characterized but not tested.

† Data in "Typ" column is at 5.0V, 25°C unless otherwise stated. These parameters are for design guidance only and are not tested.

- Note 1:** In RC oscillator configuration, the OSC1 pin is a Schmitt Trigger input. It is not recommended that the PIC16C55X be driven with external clock in RC mode.
- Note 2:** The leakage current on the  $\overline{\text{MCLR}}$  pin is strongly dependent on applied voltage level. The specified levels represent normal operating conditions. Higher leakage current may be measured at different input voltages.
- Note 3:** Negative current is defined as coming out of the pin.



## 10.2 DC Characteristics: PIC16C55X (Commercial, Industrial, Extended) PIC16LC55X(Commercial, Industrial, Extended) (Continued)

DC Characteristics		Standard Operating Conditions (unless otherwise stated)					
		Operating temperature $-40^{\circ}\text{C} \leq \text{TA} \leq +85^{\circ}\text{C}$ for industrial and $0^{\circ}\text{C} \leq \text{TA} \leq +70^{\circ}\text{C}$ for commercial and $-40^{\circ}\text{C} \leq \text{TA} \leq +125^{\circ}\text{C}$ for automotive					
		Operating voltage $V_{DD}$ range as described in DC spec Table 10-1					
Param. No.	Sym	Characteristic	Min	Typ†	Max	Unit	Conditions
D090	VOH	<b>Output High Voltage<sup>(3)</sup></b>					
		I/O ports (Except RA4)	$V_{DD}-0.7$	—	—	V	$I_{OH}=-3.0\text{ mA}$ , $V_{DD}=4.5\text{V}$ , $-40^{\circ}$ to $+85^{\circ}\text{C}$
D092		OSC2/CLKOUT	$V_{DD}-0.7$	—	—	V	$I_{OH}=-2.5\text{ mA}$ , $V_{DD}=4.5\text{V}$ , $+125^{\circ}\text{C}$
		(RC only)	$V_{DD}-0.7$	—	—	V	$I_{OH}=-1.3\text{ mA}$ , $V_{DD}=4.5\text{V}$ , $-40^{\circ}$ to $+85^{\circ}\text{C}$
*	VOD	<b>Open-Drain High Voltage</b>			10*	V	RA4 pin
		<b>Capacitive Loading Specs on Output Pins</b>					
D100	COSC2	OSC2 pin			15	pF	In XT, HS and LP modes when external clock used to drive OSC1.
D101	CIO	All I/O pins/OSC2 (in RC mode)			50	pF	

\* These parameters are characterized but not tested.

† Data in "Typ" column is at 5.0V, 25°C unless otherwise stated. These parameters are for design guidance only and are not tested.

- Note** 1: In RC oscillator configuration, the OSC1 pin is a Schmitt Trigger input. It is not recommended that the PIC16C55X be driven with external clock in RC mode.
- 2: The leakage current on the MCLR pin is strongly dependent on applied voltage level. The specified levels represent normal operating conditions. Higher leakage current may be measured at different input voltages.
- 3: Negative current is defined as coming out of the pin.

# PIC16C55X

## 10.3 Timing Parameter Symbology

The timing parameter symbols have been created with one of the following formats:

1. TppS2ppS
2. TppS

<b>T</b>			
F	Frequency	T	Time

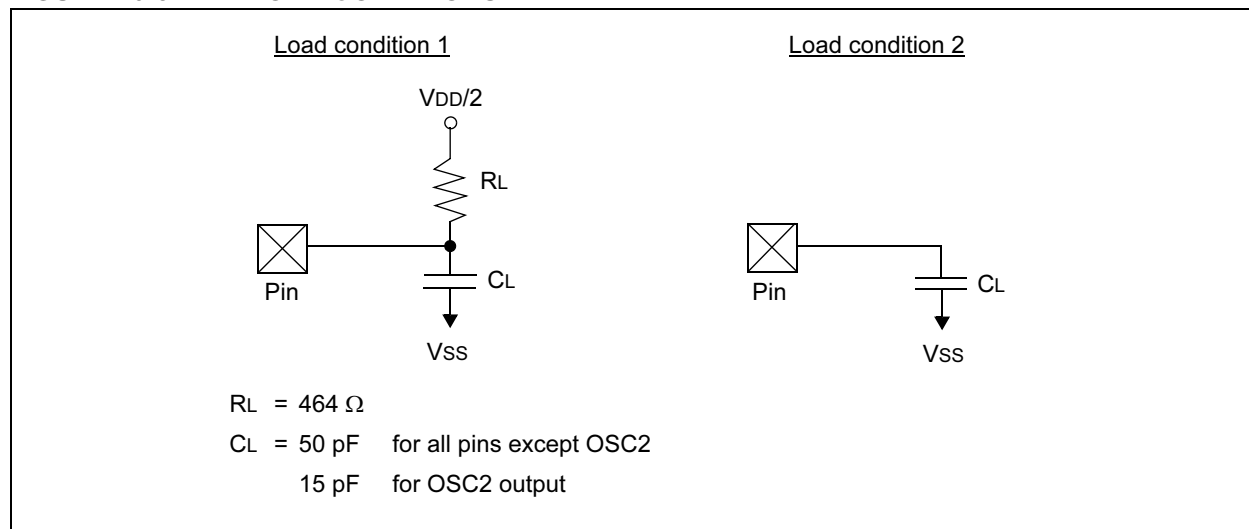
Lowercase subscripts (pp) and their meanings:

<b>pp</b>			
ck	CLKOUT	os	OSC1
io	I/O port	t0	T0CKI
mc	MCLR		

Uppercase letters and their meanings:

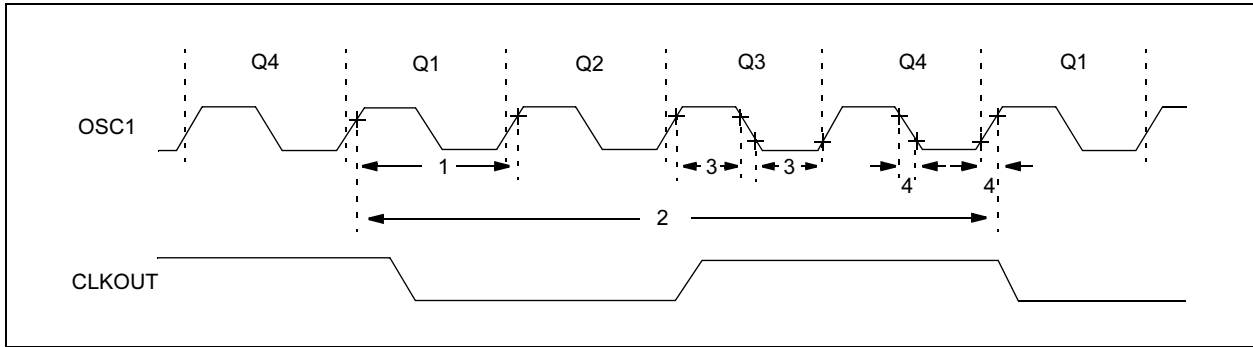
<b>S</b>			
F	Fall	P	Period
H	High	R	Rise
I	Invalid (Hi-impedance)	V	Valid
L	Low	Z	Hi-impedance

**FIGURE 10-5: LOAD CONDITIONS**



## 10.4 Timing Diagrams and Specifications

**FIGURE 10-6: EXTERNAL CLOCK TIMING**



**TABLE 10-1: EXTERNAL CLOCK TIMING REQUIREMENTS**

Parameter No.	Sym	Characteristic	Min	Typ†	Max	Units	Conditions
	Fos	External CLKIN Frequency <sup>(1)</sup>	DC	—	4	MHz	XT and RC osc mode, VDD=5.0V
			DC	—	20	MHz	HS osc mode
			DC	—	200	kHz	LP osc mode
		Oscillator Frequency <sup>(1)</sup>	DC	—	4	MHz	RC osc mode, VDD=5.0V
			0.1	—	4	MHz	XT osc mode
			1	—	20	MHz	HS osc mode
			DC	—	200	kHz	LP osc mode
1	Tosc	External CLKIN Period <sup>(1)</sup>	250	—	—	ns	XT and RC osc mode
			50	—	—	ns	HS osc mode
			5	—	—	μs	LP osc mode
		Oscillator Period <sup>(1)</sup>	250	—	—	ns	RC osc mode
			250	—	10,000	ns	XT osc mode
			50	—	1,000	ns	HS osc mode
			5	—	—	μs	LP osc mode
2	Tcy	Instruction Cycle Time <sup>(1)</sup>	1.0	Fos/4	DC	μs	Tcy=Fos/4
3*	TosL, TosH	External Clock in (OSC1) High or Low Time	100*	—	—	ns	XT osc mode
			2*	—	—	μs	LP osc mode
			20*	—	—	ns	HS osc mode
4*	TosR, TosF	External Clock in (OSC1) Rise or Fall Time	25*	—	—	ns	XT osc mode
			50*	—	—	ns	LP osc mode
			15*	—	—	ns	HS osc mode

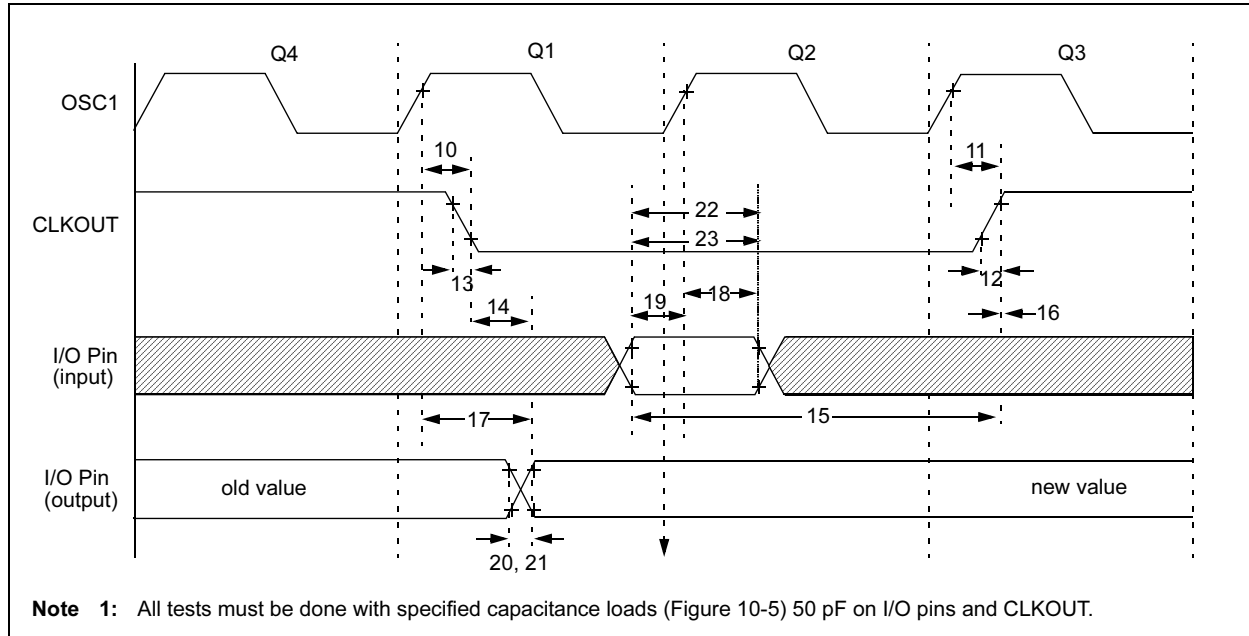
\* These parameters are characterized but not tested.

† Data in "Typ" column is at 5.0 V, 25°C unless otherwise stated. These parameters are for design guidance only and are not tested.

**Note 1:** Instruction cycle period (Tcy) equals four times the input oscillator time-base period. All specified values are based on characterization data for that particular oscillator type under standard operating conditions with the device executing code. Exceeding these specified limits may result in an unstable oscillator operation and/or higher than expected current consumption. All devices are tested to operate at "min." values with an external clock applied to the OSC1 pin. When an external clock input is used, the "Max." cycle time limit is "DC" (no clock) for all devices.

# PIC16C55X

FIGURE 10-7: CLKOUT AND I/O TIMING



**TABLE 10-2: CLKOUT AND I/O TIMING REQUIREMENTS**

Parameter #	Sym	Characteristic	Min	Typ†	Max	Units
10*	TosH2ckL	OSC1↑ to CLKOUT↓ <sup>(1)</sup>	—	75	200	ns
			—	—	400	ns
11*	TosH2ckH	OSC1↑ to CLKOUT↑ <sup>(1)</sup>	—	75	200	ns
			—	—	400	ns
12*	TckR	CLKOUT rise time <sup>(1)</sup>	—	35	100	ns
			—	—	200	ns
13*	TckF	CLKOUT fall time <sup>(1)</sup>	—	35	100	ns
			—	—	200	ns
14*	TckL2ioV	CLKOUT ↓ to Port out valid <sup>(1)</sup>	—	—	20	ns
15*	TioV2ckH	Port in valid before CLKOUT ↑ <sup>(1)</sup>	Tosc +200 ns	—	—	ns
			Tosc +400 ns	—	—	ns
16*	TckH2ioL	Port in hold after CLKOUT ↑ <sup>(1)</sup>	0	—	—	ns
17*	TosH2ioV	OSC1↑ (Q1 cycle) to Port out valid	—	50	150	ns
			—	—	300	ns
18*	TosH2ioL	OSC1↑ (Q2 cycle) to Port input invalid (I/O in hold time)	100	—	—	ns
			200	—	—	ns
19*	TioV2osH	Port input valid to OSC1↑ (I/O in setup time)	0	—	—	ns
20*	TioR	Port output rise time	—	10	40	ns
			—	—	80	ns
21*	TioF	Port output fall time	—	10	40	ns
			—	—	80	ns
22*	Tinp	RB0/INT pin high or low time	25	—	—	ns
			40	—	—	ns
23*	Trbp	RB<7:4> change interrupt high or low time	Tcy	—	—	ns

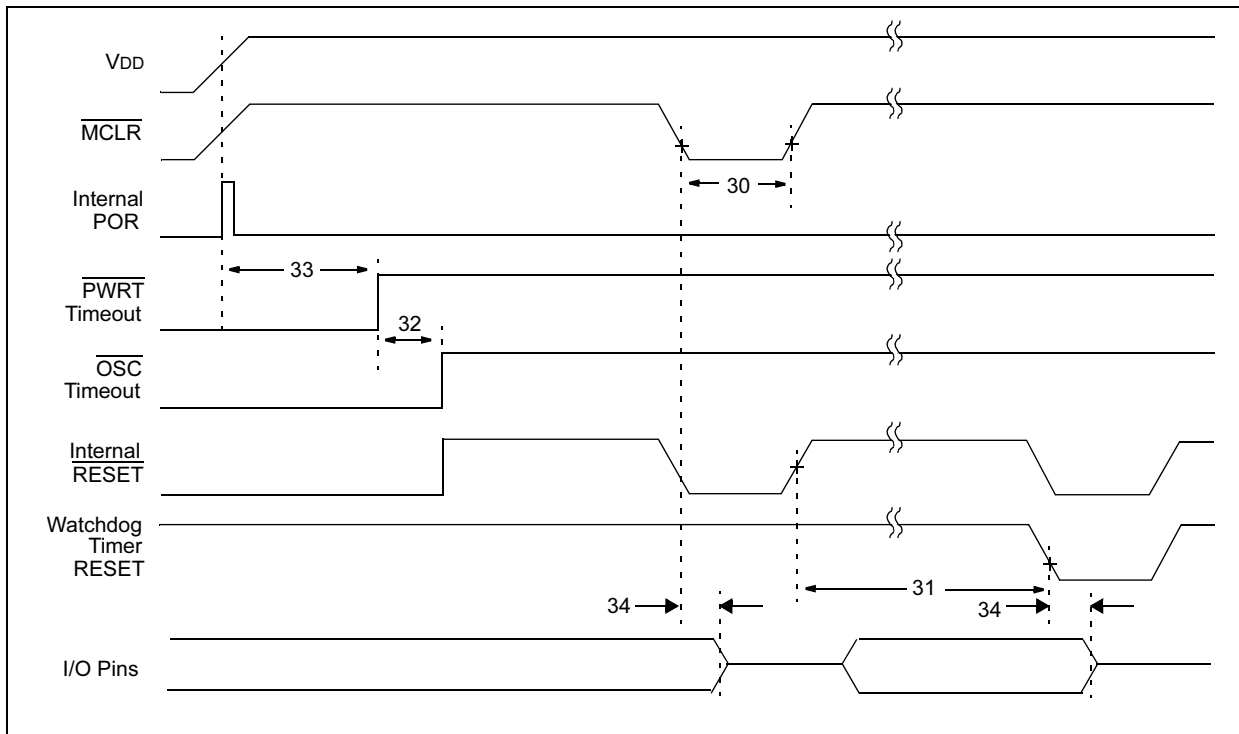
\* These parameters are characterized but not tested.

† Data in "Typ" column is at 5.0V, 25°C unless otherwise stated. These parameters are for design guidance only and are not tested.

**Note 1:** Measurements are taken in RC mode where CLKOUT output is 4 x Tosc.

# PIC16C55X

**FIGURE 10-8: RESET, WATCHDOG TIMER, OSCILLATOR START-UP TIMER AND POWER-UP TIMER TIMING**



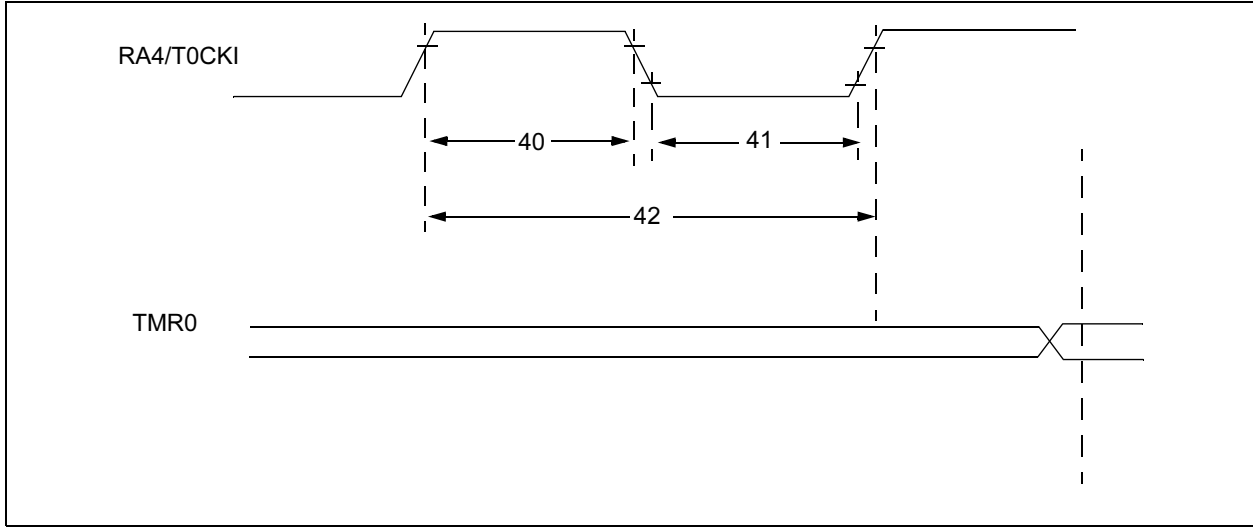
**TABLE 10-3: RESET, WATCHDOG TIMER, OSCILLATOR START-UP TIMER AND POWER-UP TIMER REQUIREMENTS**

Param No.	Sym	Characteristic	Min	Typ†	Max	Units	Conditions
30	Tmcl	MCLR Pulse Width (low)	2000	—	—	ns	-40° to +85°C
31	Twdt	Watchdog Timer Timeout Period (No Prescaler)	7*	18	33*	ms	VDD = 5.0V, -40° to +85°C
32	Tost	Oscillation Start-up Timer Period	—	1024 TOSC	—	—	TOSC = OSC1 period
33	Tpwrt	Power-up Timer Period	28*	72	132*	ms	VDD = 5.0V, -40° to +85°C
34	TIOZ	I/O hi-impedance from MCLR low	—	—	2.0*	μs	

\* These parameters are characterized but not tested.

† Data in "Typ" column is at 5.0V, 25°C unless otherwise stated. These parameters are for design guidance only and are not tested.

**FIGURE 10-9: TIMER0 CLOCK TIMING**



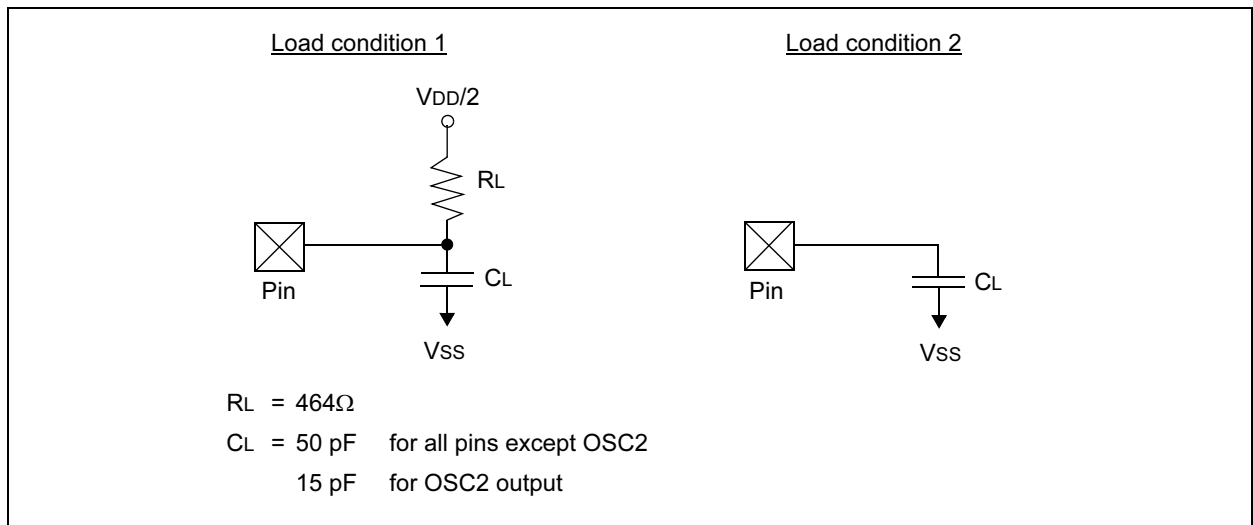
**TABLE 10-4: TIMER0 CLOCK REQUIREMENTS**

Param No.	Sym	Characteristic	Min	Typ†	Max	Units	Conditions
40	Tt0H	T0CKI High Pulse Width	No Prescaler	$0.5 T_{CY} + 20^*$	—	—	ns
			With Prescaler	10*	—	—	ns
41	Tt0L	T0CKI Low Pulse Width	No Prescaler	$0.5 T_{CY} + 20^*$	—	—	ns
			With Prescaler	10*	—	—	ns
42	Tt0P	T0CKI Period	$\frac{T_{CY} + 40^*}{N}$	—	—	ns	N = prescale value (1, 2, 4, ..., 256)

\* These parameters are characterized but not tested.

† Data in "Typ" column is at 5.0V, 25°C unless otherwise stated. These parameters are for design guidance only and are not tested.

**FIGURE 10-10: LOAD CONDITIONS**



# PIC16C55X

---

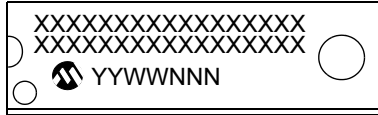
NOTES:



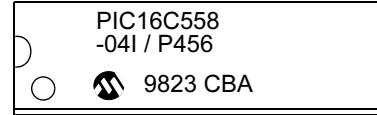
## 11.0 PACKAGING INFORMATION

### 11.1 Package Marking Information

#### 18-Lead PDIP



#### Example



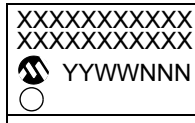
#### 28-Lead PDIP



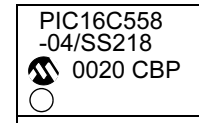
#### Example



#### 20-Lead SSOP



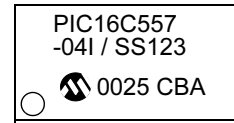
#### Example



#### 28-Lead SSOP



#### Example



**Legend:** XX...X Customer specific information\*  
 Y Year code (last digit of calendar year)  
 YY Year code (last 2 digits of calendar year)  
 WW Week code (week of January 1 is week '01')  
 NNN Alphanumeric traceability code

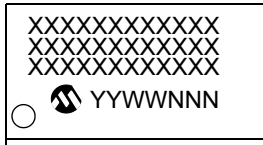
**Note:** In the event the full Microchip part number cannot be marked on one line, it will be carried over to the next line thus limiting the number of available characters for customer specific information.

\* Standard PICmicro device marking consists of Microchip part number, year code, week code, and traceability code. For PICmicro device marking beyond this, certain price adders apply. Please check with your Microchip Sales Office. For QTP devices, any special marking adders are included in QTP price.

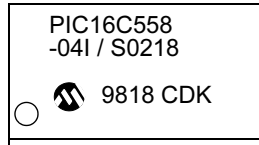
# PIC16C55X

## Package Marking Information (Cont'd)

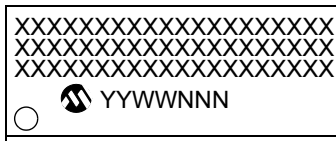
18-Lead SOIC (.300")



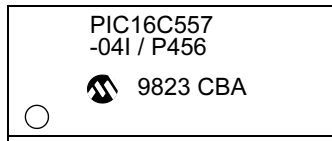
Example



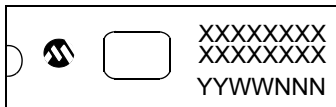
28-Lead SOIC (.300")



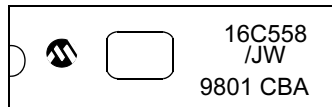
Example



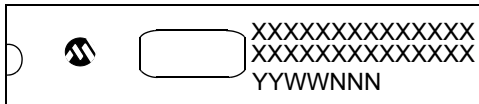
18-Lead CERDIP Windowed



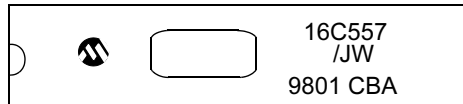
Example



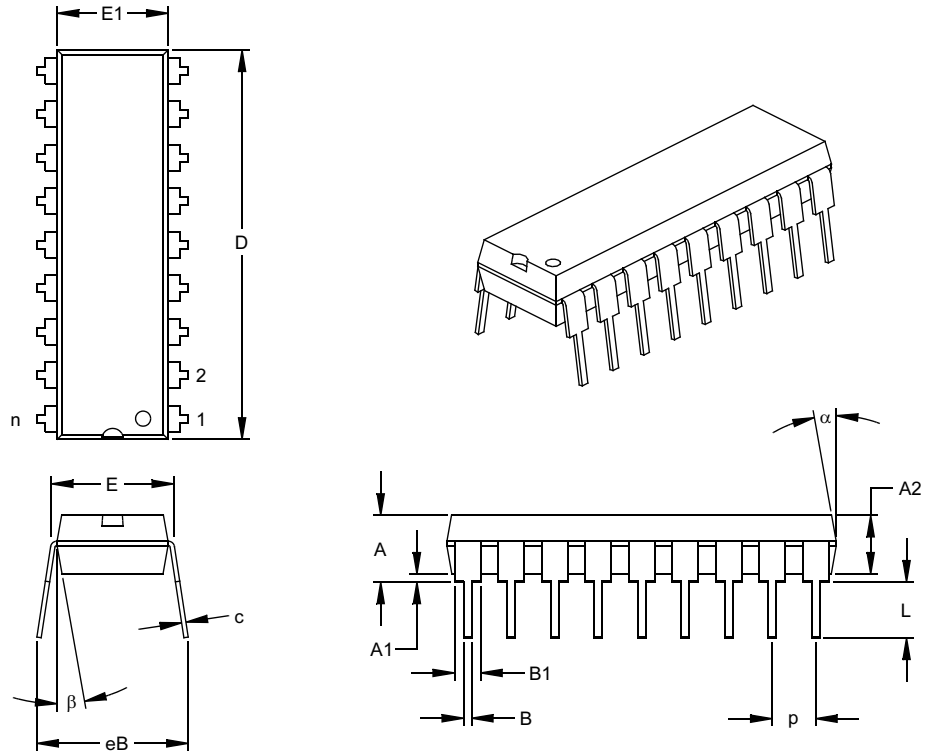
28-Lead CERDIP Windowed



Example



## 18-Lead Plastic Dual In-line (P) – 300 mil (PDIP)



Units		INCHES*			MILLIMETERS		
Dimension Limits		MIN	NOM	MAX	MIN	NOM	MAX
Number of Pins	n		18			18	
Pitch	p		.100			2.54	
Top to Seating Plane	A	.140	.155	.170	3.56	3.94	4.32
Molded Package Thickness	A2	.115	.130	.145	2.92	3.30	3.68
Base to Seating Plane	A1	.015			0.38		
Shoulder to Shoulder Width	E	.300	.313	.325	7.62	7.94	8.26
Molded Package Width	E1	.240	.250	.260	6.10	6.35	6.60
Overall Length	D	.890	.898	.905	22.61	22.80	22.99
Tip to Seating Plane	L	.125	.130	.135	3.18	3.30	3.43
Lead Thickness	c	.008	.012	.015	0.20	0.29	0.38
Upper Lead Width	B1	.045	.058	.070	1.14	1.46	1.78
Lower Lead Width	B	.014	.018	.022	0.36	0.46	0.56
Overall Row Spacing	§ eB	.310	.370	.430	7.87	9.40	10.92
Mold Draft Angle Top	α	5	10	15	5	10	15
Mold Draft Angle Bottom	β	5	10	15	5	10	15

\* Controlling Parameter

§ Significant Characteristic

Notes:

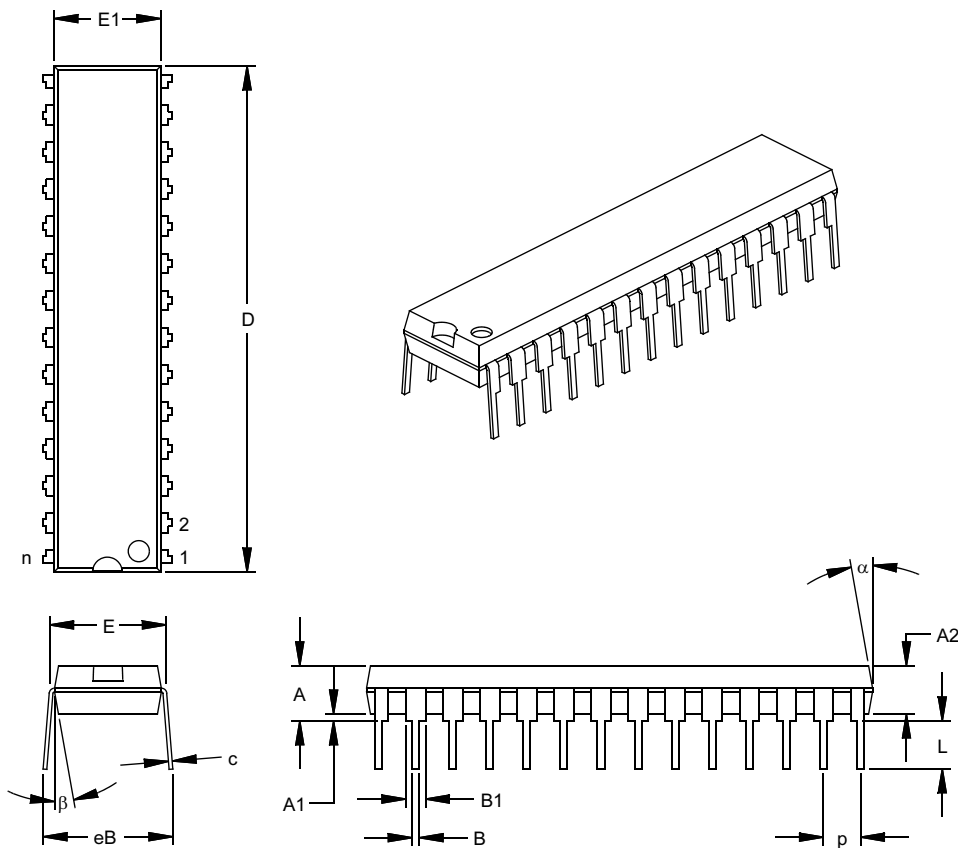
Dimensions D and E1 do not include mold flash or protrusions. Mold flash or protrusions shall not exceed .010" (0.254mm) per side.

JEDEC Equivalent: MS-001

Drawing No. C04-007

# PIC16C55X

## 28-Lead Skinny Plastic Dual In-line (SP) – 300 mil (PDIP)



Dimension Limits	Units	INCHES*			MILLIMETERS		
		MIN	NOM	MAX	MIN	NOM	MAX
Number of Pins	n		28			28	
Pitch	p		.100			2.54	
Top to Seating Plane	A	.140	.150	.160	3.56	3.81	4.06
Molded Package Thickness	A2	.125	.130	.135	3.18	3.30	3.43
Base to Seating Plane	A1	.015			0.38		
Shoulder to Shoulder Width	E	.300	.310	.325	7.62	7.87	8.26
Molded Package Width	E1	.275	.285	.295	6.99	7.24	7.49
Overall Length	D	1.345	1.365	1.385	34.16	34.67	35.18
Tip to Seating Plane	L	.125	.130	.135	3.18	3.30	3.43
Lead Thickness	c	.008	.012	.015	0.20	0.29	0.38
Upper Lead Width	B1	.040	.053	.065	1.02	1.33	1.65
Lower Lead Width	B	.016	.019	.022	0.41	0.48	0.56
Overall Row Spacing	§ eB	.320	.350	.430	8.13	8.89	10.92
Mold Draft Angle Top	α	5	10	15	5	10	15
Mold Draft Angle Bottom	β	5	10	15	5	10	15

\* Controlling Parameter

§ Significant Characteristic

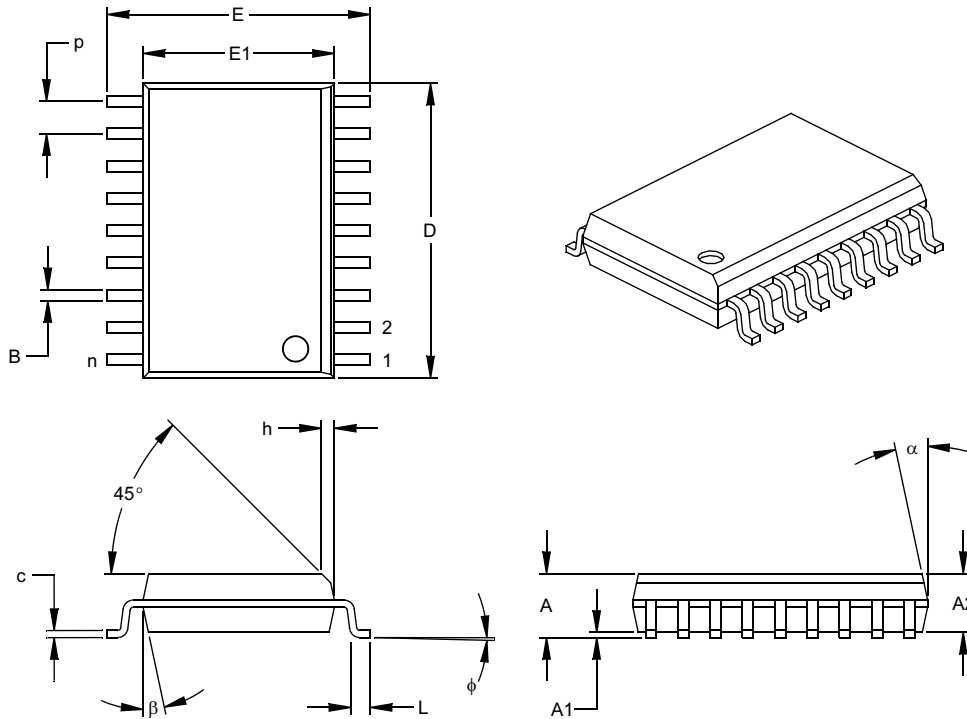
Notes:

Dimension D and E1 do not include mold flash or protrusions. Mold flash or protrusions shall not exceed .010" (0.254mm) per side.

JEDEC Equivalent: MO-095

Drawing No. C04-070

## 18-Lead Plastic Small Outline (SO) – Wide, 300 mil (SOIC)



Units		INCHES*			MILLIMETERS		
Dimension Limits		MIN	NOM	MAX	MIN	NOM	MAX
Number of Pins	n		18			18	
Pitch	p		.050			1.27	
Overall Height	A	.093	.099	.104	2.36	2.50	2.64
Molded Package Thickness	A2	.088	.091	.094	2.24	2.31	2.39
Standoff §	A1	.004	.008	.012	0.10	0.20	0.30
Overall Width	E	.394	.407	.420	10.01	10.34	10.67
Molded Package Width	E1	.291	.295	.299	7.39	7.49	7.59
Overall Length	D	.446	.454	.462	11.33	11.53	11.73
Chamfer Distance	h	.010	.020	.029	0.25	0.50	0.74
Foot Length	L	.016	.033	.050	0.41	0.84	1.27
Foot Angle	φ	0	4	8	0	4	8
Lead Thickness	c	.009	.011	.012	0.23	0.27	0.30
Lead Width	B	.014	.017	.020	0.36	0.42	0.51
Mold Draft Angle Top	α	0	12	15	0	12	15
Mold Draft Angle Bottom	β	0	12	15	0	12	15

\* Controlling Parameter

§ Significant Characteristic

Notes:

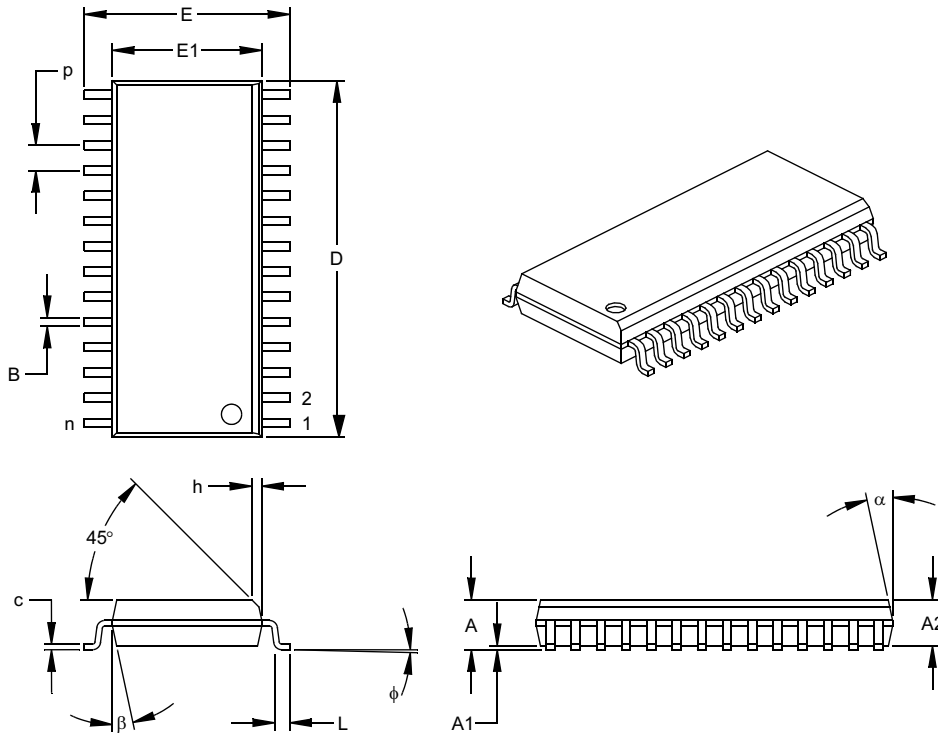
Dimensions D and E1 do not include mold flash or protrusions. Mold flash or protrusions shall not exceed .010" (0.254mm) per side.

JEDEC Equivalent: MS-013

Drawing No. C04-051

# PIC16C55X

## 28-Lead Plastic Small Outline (SO) – Wide, 300 mil (SOIC)



Dimension Limits	Units	INCHES*			MILLIMETERS		
		MIN	NOM	MAX	MIN	NOM	MAX
Number of Pins	n		28			28	
Pitch	p		.050			1.27	
Overall Height	A	.093	.099	.104	2.36	2.50	2.64
Molded Package Thickness	A2	.088	.091	.094	2.24	2.31	2.39
Standoff §	A1	.004	.008	.012	0.10	0.20	0.30
Overall Width	E	.394	.407	.420	10.01	10.34	10.67
Molded Package Width	E1	.288	.295	.299	7.32	7.49	7.59
Overall Length	D	.695	.704	.712	17.65	17.87	18.08
Chamfer Distance	h	.010	.020	.029	0.25	0.50	0.74
Foot Length	L	.016	.033	.050	0.41	0.84	1.27
Foot Angle Top	φ	0	4	8	0	4	8
Lead Thickness	c	.009	.011	.013	0.23	0.28	0.33
Lead Width	B	.014	.017	.020	0.36	0.42	0.51
Mold Draft Angle Top	α	0	12	15	0	12	15
Mold Draft Angle Bottom	β	0	12	15	0	12	15

\* Controlling Parameter

§ Significant Characteristic

**Notes:**

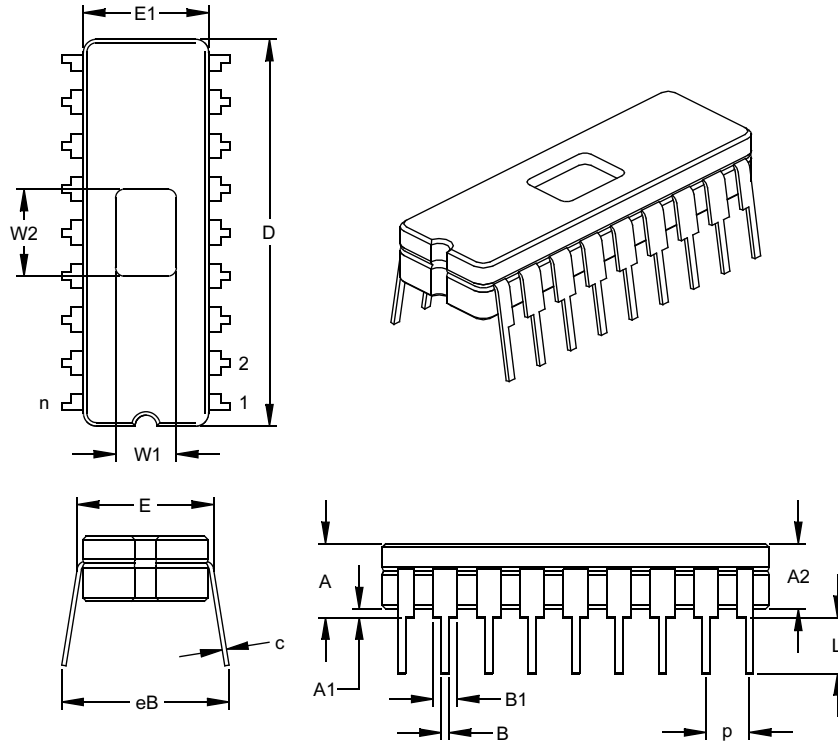
Dimensions D and E1 do not include mold flash or protrusions. Mold flash or protrusions shall not exceed

.010" (0.254mm) per side.

JEDEC Equivalent: MS-013

Drawing No. C04-052

## 18-Lead Ceramic Dual In-line with Window (JW) – 300 mil (CERDIP)

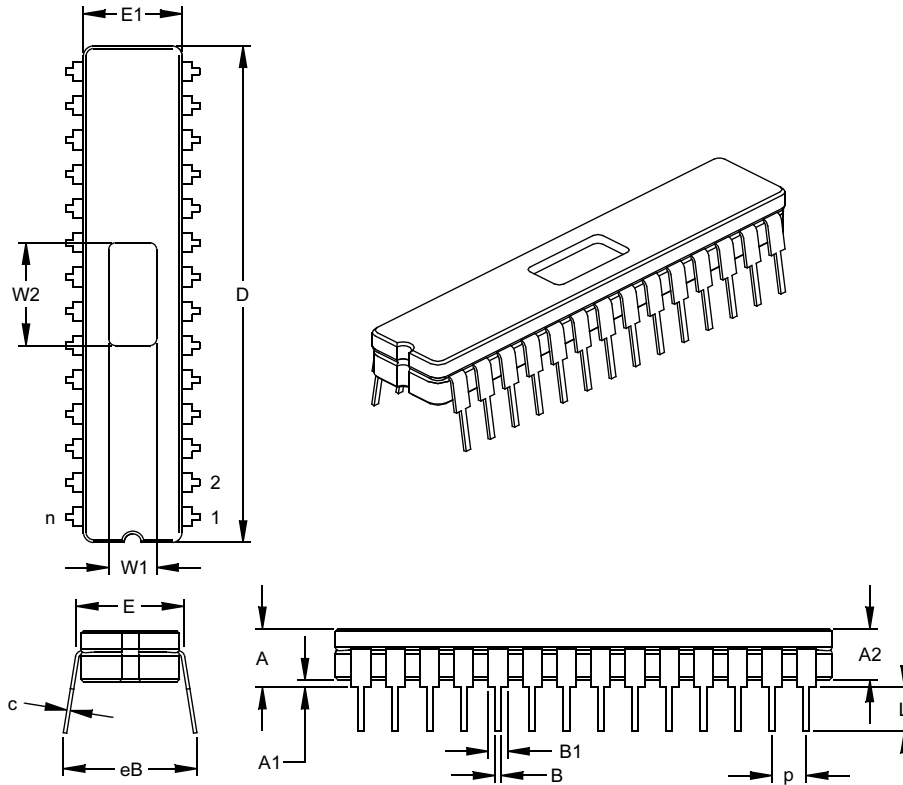


Units		INCHES*			MILLIMETERS		
Dimension Limits		MIN	NOM	MAX	MIN	NOM	MAX
Number of Pins	n		18			18	
Pitch	p		.100			2.54	
Top to Seating Plane	A	.170	.183	.195	4.32	4.64	4.95
Ceramic Package Height	A2	.155	.160	.165	3.94	4.06	4.19
Standoff	A1	.015	.023	.030	0.38	0.57	0.76
Shoulder to Shoulder Width	E	.300	.313	.325	7.62	7.94	8.26
Ceramic Pkg. Width	E1	.285	.290	.295	7.24	7.37	7.49
Overall Length	D	.880	.900	.920	22.35	22.86	23.37
Tip to Seating Plane	L	.125	.138	.150	3.18	3.49	3.81
Lead Thickness	c	.008	.010	.012	0.20	0.25	0.30
Upper Lead Width	B1	.050	.055	.060	1.27	1.40	1.52
Lower Lead Width	B	.016	.019	.021	0.41	0.47	0.53
Overall Row Spacing	§ eB	.345	.385	.425	8.76	9.78	10.80
Window Width	W1	.130	.140	.150	3.30	3.56	3.81
Window Length	W2	.190	.200	.210	4.83	5.08	5.33

\* Controlling Parameter  
 § Significant Characteristic  
 JEDEC Equivalent: MO-036  
 Drawing No. C04-010

# PIC16C55X

## 28-Lead Ceramic Dual In-line with Window (JW) – 300 mil (CERDIP)



Dimension Limits	Units	INCHES*			MILLIMETERS		
		MIN	NOM	MAX	MIN	NOM	MAX
Number of Pins	n		28			28	
Pitch	p		.100			2.54	
Top to Seating Plane	A	.170	.183	.195	4.32	4.64	4.95
Ceramic Package Height	A2	.155	.160	.165	3.94	4.06	4.19
Standoff	A1	.015	.023	.030	0.38	0.57	0.76
Shoulder to Shoulder Width	E	.300	.313	.325	7.62	7.94	8.26
Ceramic Pkg. Width	E1	.285	.290	.295	7.24	7.37	7.49
Overall Length	D	1.430	1.458	1.485	36.32	37.02	37.72
Tip to Seating Plane	L	.135	.140	.145	3.43	3.56	3.68
Lead Thickness	c	.008	.010	.012	0.20	0.25	0.30
Upper Lead Width	B1	.050	.058	.065	1.27	1.46	1.65
Lower Lead Width	B	.016	.019	.021	0.41	0.47	0.53
Overall Row Spacing §	eB	.345	.385	.425	8.76	9.78	10.80
Window Width	W1	.130	.140	.150	3.30	3.56	3.81
Window Length	W2	.290	.300	.310	7.37	7.62	7.87

\* Controlling Parameter

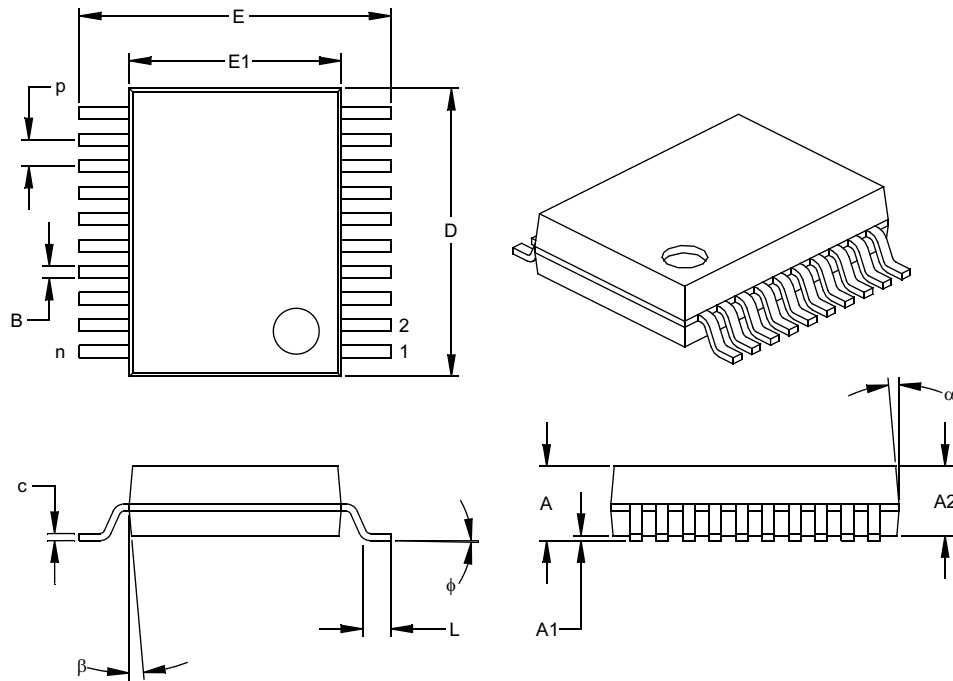
§ Significant Characteristic

JEDEC Equivalent: MO-058

Drawing No. C04-080



## 20-Lead Plastic Shrink Small Outline (SS) – 209 mil, 5.30 mm (SSOP)



Units		INCHES*			MILLIMETERS		
Dimension Limits		MIN	NOM	MAX	MIN	NOM	MAX
Number of Pins	n		20			20	
Pitch	p		.026			0.65	
Overall Height	A	.068	.073	.078	1.73	1.85	1.98
Molded Package Thickness	A2	.064	.068	.072	1.63	1.73	1.83
Standoff §	A1	.002	.006	.010	0.05	0.15	0.25
Overall Width	E	.299	.309	.322	7.59	7.85	8.18
Molded Package Width	E1	.201	.207	.212	5.11	5.25	5.38
Overall Length	D	.278	.284	.289	7.06	7.20	7.34
Foot Length	L	.022	.030	.037	0.56	0.75	0.94
Lead Thickness	c	.004	.007	.010	0.10	0.18	0.25
Foot Angle	φ	0	4	8	0.00	101.60	203.20
Lead Width	B	.010	.013	.015	0.25	0.32	0.38
Mold Draft Angle Top	α	0	5	10	0	5	10
Mold Draft Angle Bottom	β	0	5	10	0	5	10

\* Controlling Parameter

§ Significant Characteristic

**Notes:**

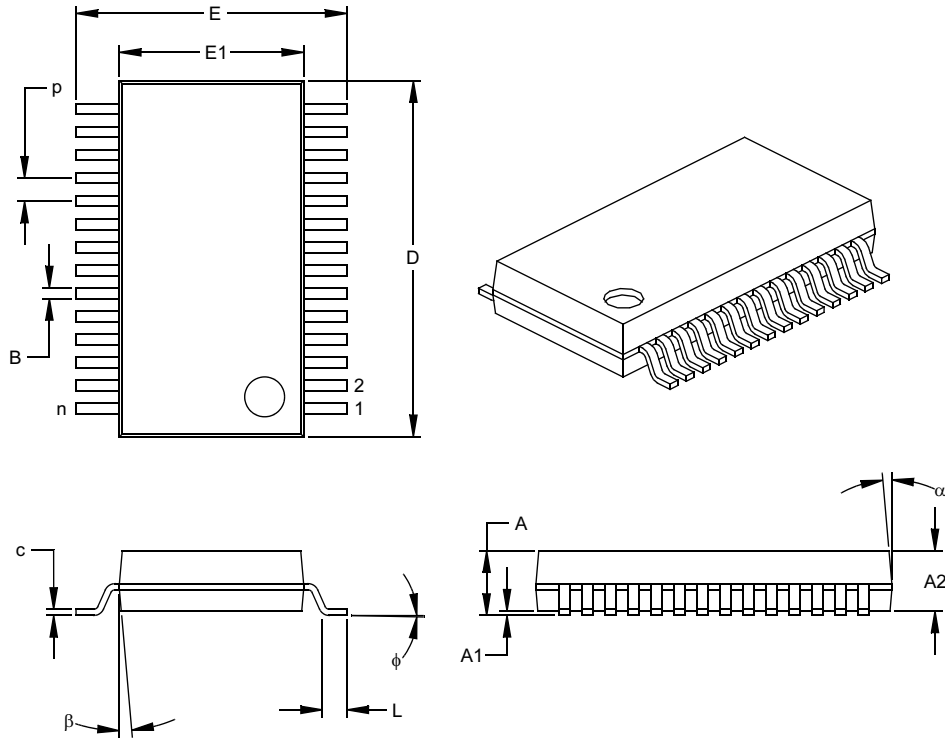
Dimensions D and E1 do not include mold flash or protrusions. Mold flash or protrusions shall not exceed .010" (0.254mm) per side.

JEDEC Equivalent: MO-150

Drawing No. C04-072

# PIC16C55X

28-Lead Plastic Shrink Small Outline (SS) – 209 mil, 5.30 mm (SSOP)



Dimension Limits	Units	INCHES			MILLIMETERS*		
		MIN	NOM	MAX	MIN	NOM	MAX
Number of Pins	n		28			28	
Pitch	p		.026			0.65	
Overall Height	A	.068	.073	.078	1.73	1.85	1.98
Molded Package Thickness	A2	.064	.068	.072	1.63	1.73	1.83
Standoff §	A1	.002	.006	.010	0.05	0.15	0.25
Overall Width	E	.299	.309	.319	7.59	7.85	8.10
Molded Package Width	E1	.201	.207	.212	5.11	5.25	5.38
Overall Length	D	.396	.402	.407	10.06	10.20	10.34
Foot Length	L	.022	.030	.037	0.56	0.75	0.94
Lead Thickness	c	.004	.007	.010	0.10	0.18	0.25
Foot Angle	φ	0	4	8	0.00	101.60	203.20
Lead Width	B	.010	.013	.015	0.25	0.32	0.38
Mold Draft Angle Top	α	0	5	10	0	5	10
Mold Draft Angle Bottom	β	0	5	10	0	5	10

\* Controlling Parameter  
§ Significant Characteristic

Notes:  
Dimensions D and E1 do not include mold flash or protrusions. Mold flash or protrusions shall not exceed .010" (0.254mm) per side.  
JEDEC Equivalent: MS-150  
Drawing No. C04-073

## APPENDIX A: ENHANCEMENTS

The following are the list of enhancements over the PIC16C5X microcontroller family:

1. Instruction word length is increased to 14 bits. This allows larger page sizes both in program memory (4K now as opposed to 512 before) and register file (up to 128 bytes now versus 32 bytes before).
2. A PC high latch register (PCLATH) is added to handle program memory paging. PA2, PA1, PA0 bits are removed from STATUS register.
3. Data memory paging is slightly redefined. STATUS register is modified.
4. Four new instructions have been added: RETURN, RETFIE, ADDLW, and SUBLW. Two instructions TRIS and OPTION are being phased out although they are kept for compatibility with PIC16C5X.
5. OPTION and TRIS registers are made addressable.
6. Interrupt capability is added. Interrupt vector is at 0004h.
7. Stack size is increased to 8 deep.
8. RESET vector is changed to 0000h.
9. RESET of all registers is revised. Three different RESET (and wake-up) types are recognized. Registers are reset differently.
10. Wake-up from SLEEP through interrupt is added.
11. Two separate timers, Oscillator Start-up Timer (OST) and Power-up Timer (PWRT) are included for more reliable power-up. These timers are invoked selectively to avoid unnecessary delays on power-up and wake-up.
12. PORTB has weak pull-ups and interrupt-on-change feature.
13. Timer0 clock input, T0CKI pin is also a port pin (RA4/T0CKI) and has a TRIS bit.
14. FSR is made a full 8-bit register.
15. "In-circuit programming" is made possible. The user can program PIC16C55X devices using only five pins: VDD, VSS, VPP, RB6 (clock) and RB7 (data in/out).
16. PCON status register is added with a Power-on Reset ( $\overline{\text{POR}}$ ) status bit.
17. Code protection scheme is enhanced such that portions of the program memory can be protected, while the remainder is unprotected.
18. PORTA inputs are now Schmitt Trigger inputs.

## APPENDIX B: COMPATIBILITY

To convert code written for PIC16C5X to PIC16C55X, the user should take the following steps:

1. Remove any program memory page select operations (PA2, PA1, PA0 bits) for CALL, GOTO.
2. Revisit any computed jump operations (write to PC or add to PC, etc.) to make sure page bits are set properly under the new scheme.
3. Eliminate any data memory page switching. Redefine data variables to reallocate them.
4. Verify all writes to STATUS, OPTION, and FSR registers since these have changed.
5. Change RESET vector to 0000h.

# PIC16C55X

---

NOTES:

## INDEX

### A

ADDLW Instruction .....	55
ADDWF Instruction .....	55
ANDLW Instruction .....	55
ANDWF Instruction .....	55
Architectural Overview .....	9
Assembler	
MPASM Assembler .....	67

### B

BCF Instruction .....	56
Block Diagram	
TIMER0 .....	47
TMR0/WDT PRESCALER .....	50
BSF Instruction .....	56
BTFSC Instruction .....	56
BTFSS Instruction .....	57

### C

CALL Instruction .....	57
Clocking Scheme/Instruction Cycle .....	12
CLRF Instruction .....	57
CLRW Instruction .....	58
CLRWDI Instruction .....	58
Code Protection .....	46
COMF Instruction .....	58
Configuration Bits .....	31

### D

Data Memory Organization .....	13
DECF Instruction .....	58
DECFSZ Instruction .....	59
Development Support .....	67

### E

Errata .....	3
External Crystal Oscillator Circuit .....	34

### G

General purpose Register File .....	13
GOTO Instruction .....	59

### I

I/O Ports .....	23
I/O Programming Considerations .....	28
ICEPIC In-Circuit Emulator .....	68
ID Locations .....	46
INCF Instruction .....	59
INCFSZ Instruction .....	60
In-Circuit Serial Programming .....	46
Indirect Addressing, INDF and FSR Registers .....	21
Instruction Flow/Pipelining .....	12
Instruction Set	
ADDLW .....	55
ADDWF .....	55
ANDLW .....	55
ANDWF .....	55
BCF .....	56
BSF .....	56
BTFSC .....	56
BTFSS .....	57
CALL .....	57
CLRF .....	57

CLRW .....	58
CLRWDI .....	58
COMF .....	58
DECF .....	58
DECFSZ .....	59
GOTO .....	59
INCF .....	59
INCFSZ .....	60
IORLW .....	60
IORWF .....	60
MOVF .....	61
MOVLW .....	60
MOVWF .....	61
NOP .....	61
OPTION .....	61
RETFIE .....	62
RETLW .....	62
RETURN .....	62
RLF .....	62
RRF .....	63
SLEEP .....	63
SUBLW .....	63
SUBWF .....	64
SWAPF .....	64
TRIS .....	64
XORLW .....	65
XORWF .....	65

Instruction Set Summary .....	53
INT Interrupt .....	42
INTCON Register .....	19
Interrupts .....	41
IORLW Instruction .....	60
IORWF Instruction .....	60

### K

KEELOQ Evaluation and Programming Tools .....	70
-----------------------------------------------	----

### M

MOVF Instruction .....	61
MOVLW Instruction .....	60
MOVWF Instruction .....	61
MPLAB C17 and MPLAB C18 C Compilers .....	67
MPLAB ICD In-Circuit Debugger .....	69
MPLAB ICE High Performance Universal In-Circuit Emulator with MPLAB IDE .....	68
MPLAB Integrated Development Environment Software .....	67
MPLINK Object Linker/MPLIB Object Librarian .....	68

### N

NOP Instruction .....	61
-----------------------	----

### O

One-Time-Programmable (OTP) Devices .....	7
OPTION Instruction .....	61
OPTION Register .....	18
Oscillator Configurations .....	33
Oscillator Start-up Timer (OST) .....	36

### P

PCL and PCLATH .....	21
PCON Register .....	20
PICDEM 1 Low Cost PICmicro Demonstration Board .....	69
PICDEM 17 Demonstration Board .....	70
PICDEM 2 Low Cost PIC16CXX Demonstration Board .....	69
PICDEM 3 Low Cost PIC16CXXX Demonstration Board .....	70

# PIC16C55X

---

PICSTART Plus Entry Level Development Programmer ....	69
Port RB Interrupt .....	42
PORTA .....	23
PORTB .....	25, 27
Power Control/Status Register (PCON) .....	37
Power-Down Mode (SLEEP) .....	45
Power-On Reset (POR) .....	36
Power-up Timer (PWRT) .....	36
Prescaler .....	49
PRO MATE II Universal Device Programmer .....	69
Program Memory Organization .....	13

## Q

Quick-Turnaround-Production (QTP) Devices .....	7
-------------------------------------------------	---

## R

RC Oscillator .....	34
Reset .....	35
RETFIE Instruction .....	62
RETLW Instruction .....	62
RETURN Instruction .....	62
RLF Instruction .....	62
RRF Instruction .....	63

## S

Serialized Quick-Turnaround-Production (SQTP) Devices ...	7
SLEEP Instruction .....	63
Software Simulator (MPLAB SIM) .....	68
Special Features of the CPU .....	31
Special Function Registers .....	15
Stack .....	21
Status Register .....	17
SUBLW Instruction .....	63
SUBWF Instruction .....	64
SWAPF Instruction .....	64

## T

Timer0	
TIMER0 .....	47
TIMER0 (TMR0) Interrupt .....	47
TIMER0 (TMR0) Module .....	47
TMR0 with External Clock .....	49
Timer1	
Switching Prescaler Assignment .....	51
Timing Diagrams and Specifications .....	81
TMR0 Interrupt .....	42
TRIS Instruction .....	64
TRISA .....	23
TRISB .....	25, 27

## W

Watchdog Timer (WDT) .....	43
WWW, On-Line Support .....	3

## X

XORLW Instruction .....	65
XORWF Instruction .....	65

## ON-LINE SUPPORT

Microchip provides on-line support on the Microchip World Wide Web site.

The web site is used by Microchip as a means to make files and information easily available to customers. To view the site, the user must have access to the Internet and a web browser, such as Netscape® or Microsoft® Internet Explorer. Files are also available for FTP download from our FTP site.

### Connecting to the Microchip Internet Web Site

The Microchip web site is available at the following URL:

**[www.microchip.com](http://www.microchip.com)**

The file transfer site is available by using an FTP service to connect to:

**<ftp://ftp.microchip.com>**

The web site and file transfer site provide a variety of services. Users may download files for the latest Development Tools, Data Sheets, Application Notes, User's Guides, Articles and Sample Programs. A variety of Microchip specific business information is also available, including listings of Microchip sales offices, distributors and factory representatives. Other data available for consideration is:

- Latest Microchip Press Releases
- Technical Support Section with Frequently Asked Questions
- Design Tips
- Device Errata
- Job Postings
- Microchip Consultant Program Member Listing
- Links to other useful web sites related to Microchip Products
- Conferences for products, Development Systems, technical information and more
- Listing of seminars and events

## SYSTEMS INFORMATION AND UPGRADE HOT LINE

The Systems Information and Upgrade Line provides system users a listing of the latest versions of all of Microchip's development systems software products. Plus, this line provides information on how customers can receive the most current upgrade kits. The Hot Line Numbers are:

1-800-755-2345 for U.S. and most of Canada, and

1-480-792-7302 for the rest of the world.

092002

# PIC16C55X

---

## READER RESPONSE

It is our intention to provide you with the best documentation possible to ensure successful use of your Microchip product. If you wish to provide your comments on organization, clarity, subject matter, and ways in which our documentation can better serve you, please FAX your comments to the Technical Publications Manager at (480) 792-4150.

Please list the following information, and use this outline to provide us with your comments about this document.

To: Technical Publications Manager  
RE: Reader Response  
From: Name \_\_\_\_\_  
Company \_\_\_\_\_  
Address \_\_\_\_\_  
City / State / ZIP / Country \_\_\_\_\_  
Telephone: (\_\_\_\_\_) \_\_\_\_\_ - \_\_\_\_\_ FAX: (\_\_\_\_\_) \_\_\_\_\_ - \_\_\_\_\_

Application (optional):

Would you like a reply? \_\_\_Y \_\_\_N

Device: PIC16C55X Literature Number: DS40143D

Questions:

1. What are the best features of this document?

---

---

2. How does this document meet your hardware and software development needs?

---

---

3. Do you find the organization of this document easy to follow? If not, why?

---

---

4. What additions to the document do you think would enhance the structure and subject?

---

---

5. What deletions from the document could be made without affecting the overall usefulness?

---

---

6. Is there any incorrect or misleading information (what and where)?

---

---

7. How would you improve this document?

---

---



## PRODUCT IDENTIFICATION SYSTEM

To order or obtain information, e.g., on pricing or delivery, refer to the factory or the listed sales office.

<u>PART NO.</u>	<u>X</u>	<u>/XX</u>	<u>XXX</u>
Device	Temperature Range	Package	Pattern
Device	PIC17C756: Standard VDD range PIC17C756T: (Tape and Reel) PIC17LC756: Extended VDD range		
Temperature Range	- = 0°C to +70°C I = -40°C to +85°C		
Package	CL = Windowed LCC PT = TQFP L = PLCC		
Pattern	QTP, SQTP, ROM Code (factory specified) or Special Requirements. Blank for OTP and Windowed devices.		

**Examples:**

- a) PIC17C756-16L Commercial Temp., PLCC package, 16 MHz, normal VDD limits
- b) PIC17LC756-08/PT Commercial Temp., TQFP package, 8MHz, extended VDD limits
- c) PIC17C756-33I/PT Industrial Temp., TQFP package, 33 MHz, normal VDD limits

\* JW Devices are UV erasable and can be programmed to any device configuration. JW Devices meet the electrical requirement of each oscillator type.

## Sales and Support

### **Data Sheets**

Products supported by a preliminary Data Sheet may have an errata sheet describing minor operational differences and recommended workarounds. To determine if an errata sheet exists for a particular device, please contact one of the following:

1. Your local Microchip sales office
2. The Microchip Corporate Literature Center U.S. FAX: (480) 792-7277
3. The Microchip Worldwide Site ([www.microchip.com](http://www.microchip.com))

Please specify which device, revision of silicon and Data Sheet (include Literature #) you are using.

### **New Customer Notification System**

Register on our web site ([www.microchip.com/cn](http://www.microchip.com/cn)) to receive the most current information on our products.

# PIC16C55X

---

---

NOTES:

NOTES:



# MICROCHIP

## WORLDWIDE SALES AND SERVICE

### AMERICAS

#### Corporate Office

2355 West Chandler Blvd.  
Chandler, AZ 85224-6199  
Tel: 480-792-7200 Fax: 480-792-7277  
Technical Support: 480-792-7627  
Web Address: <http://www.microchip.com>

#### Rocky Mountain

2355 West Chandler Blvd.  
Chandler, AZ 85224-6199  
Tel: 480-692-7966 Fax: 480-792-4338

#### Atlanta

500 Sugar Mill Road, Suite 200B  
Atlanta, GA 30350  
Tel: 770-640-0034 Fax: 770-640-0307

#### Boston

2 Lan Drive, Suite 120  
Westford, MA 01886  
Tel: 978-692-3848 Fax: 978-692-3821

#### Chicago

333 Pierce Road, Suite 180  
Itasca, IL 60143  
Tel: 630-285-0071 Fax: 630-285-0075

#### Dallas

4570 Westgrove Drive, Suite 160  
Addison, TX 75001  
Tel: 972-818-7423 Fax: 972-818-2924

#### Detroit

Tri-Atria Office Building  
32255 Northwestern Highway, Suite 190  
Farmington Hills, MI 48334  
Tel: 248-538-2250 Fax: 248-538-2260

#### Kokomo

2767 S. Albright Road  
Kokomo, Indiana 46902  
Tel: 765-864-8360 Fax: 765-864-8387

#### Los Angeles

18201 Von Karman, Suite 1090  
Irvine, CA 92612  
Tel: 949-263-1888 Fax: 949-263-1338

#### New York

150 Motor Parkway, Suite 202  
Hauppauge, NY 11788  
Tel: 631-273-5305 Fax: 631-273-5335

#### San Jose

Microchip Technology Inc.  
2107 North First Street, Suite 590  
San Jose, CA 95131  
Tel: 408-436-7950 Fax: 408-436-7955

#### Toronto

6285 Northam Drive, Suite 108  
Mississauga, Ontario L4V 1X5, Canada  
Tel: 905-673-0699 Fax: 905-673-6509

### ASIA/PACIFIC

#### Australia

Microchip Technology Australia Pty Ltd  
Suite 22, 41 Rawson Street  
Epping 2121, NSW  
Australia  
Tel: 61-2-9868-6733 Fax: 61-2-9868-6755

#### China - Beijing

Microchip Technology Consulting (Shanghai)  
Co., Ltd., Beijing Liaison Office  
Unit 915  
Bei Hai Wan Tai Bldg.  
No. 6 Chaoyangmen Beidajie  
Beijing, 100027, No. China  
Tel: 86-10-85282100 Fax: 86-10-85282104

#### China - Chengdu

Microchip Technology Consulting (Shanghai)  
Co., Ltd., Chengdu Liaison Office  
Rm. 2401, 24th Floor,  
Ming Xing Financial Tower  
No. 88 TIDU Street  
Chengdu 610016, China  
Tel: 86-28-86766200 Fax: 86-28-86766599

#### China - Fuzhou

Microchip Technology Consulting (Shanghai)  
Co., Ltd., Fuzhou Liaison Office  
Unit 28F, World Trade Plaza  
No. 71 Wusi Road  
Fuzhou 350001, China  
Tel: 86-591-7503506 Fax: 86-591-7503521

#### China - Shanghai

Microchip Technology Consulting (Shanghai)  
Co., Ltd.  
Room 701, Bldg. B  
Far East International Plaza  
No. 317 Xian Xia Road  
Shanghai, 200051  
Tel: 86-21-6275-5700 Fax: 86-21-6275-5060

#### China - Shenzhen

Microchip Technology Consulting (Shanghai)  
Co., Ltd., Shenzhen Liaison Office  
Rm. 1315, 13/F, Shenzhen Kerry Centre,  
Renminnan Lu  
Shenzhen 518001, China  
Tel: 86-755-82350361 Fax: 86-755-82366086

#### China - Hong Kong SAR

Microchip Technology Hongkong Ltd.  
Unit 901-6, Tower 2, Metroplaza  
223 Hing Fong Road  
Kwai Fong, N.T., Hong Kong  
Tel: 852-2401-1200 Fax: 852-2401-3431

#### India

Microchip Technology Inc.  
India Liaison Office  
Divyasree Chambers  
1 Floor, Wing A (A3/A4)  
No. 11, O'Shaugnessey Road  
Bangalore, 560 025, India  
Tel: 91-80-2290061 Fax: 91-80-2290062

### Japan

Microchip Technology Japan K.K.  
Benex S-1 6F  
3-18-20, Shinyokohama  
Kohoku-Ku, Yokohama-shi  
Kanagawa, 222-0033, Japan  
Tel: 81-45-471- 6166 Fax: 81-45-471-6122

### Korea

Microchip Technology Korea  
168-1, Youngbo Bldg. 3 Floor  
Samsung-Dong, Kangnam-Ku  
Seoul, Korea 135-882  
Tel: 82-2-554-7200 Fax: 82-2-558-5934

### Singapore

Microchip Technology Singapore Pte Ltd.  
200 Middle Road  
#07-02 Prime Centre  
Singapore, 188980  
Tel: 65-6334-8870 Fax: 65-6334-8850

### Taiwan

Microchip Technology (Barbados) Inc.,  
Taiwan Branch  
11F-3, No. 207  
Tung Hua North Road  
Taipei, 105, Taiwan  
Tel: 886-2-2717-7175 Fax: 886-2-2545-0139

### EUROPE

#### Austria

Microchip Technology Austria GmbH  
Durisolstrasse 2  
A-4600 Wels  
Austria  
Tel: 43-7242-2244-399  
Fax: 43-7242-2244-393

#### Denmark

Microchip Technology Nordic ApS  
Regus Business Centre  
Lautrup høj 1-3  
Ballerup DK-2750 Denmark  
Tel: 45 4420 9895 Fax: 45 4420 9910

#### France

Microchip Technology SARL  
Parc d'Activite du Moulin de Massy  
43 Rue du Saule Trapu  
Batiment A - 1er Etage  
91300 Massy, France  
Tel: 33-1-69-53-63-20 Fax: 33-1-69-30-90-79

#### Germany

Microchip Technology GmbH  
Steinheilstrasse 10  
D-85737 Ismaning, Germany  
Tel: 49-89-627-144 0 Fax: 49-89-627-144-44

#### Italy

Microchip Technology SRL  
Centro Direzionale Colleoni  
Palazzo Taurus 1 V. Le Colleoni 1  
20041 Agrate Brianza  
Milan, Italy  
Tel: 39-039-65791-1 Fax: 39-039-6899883

#### United Kingdom

Microchip Ltd.  
505 Eskdale Road  
Winkersley Triangle  
Wokingham  
Berkshire, England RG41 5TU  
Tel: 44 118 921 5869 Fax: 44-118 921-5820

08/01/02