

---

---

## 8-Pin MCU with High-Precision 16-Bit PWMs

---

---

### Description:

PIC12(L)F1571/2 microcontrollers combine the capabilities of 16-bit PWMs with Analog to suit a variety of applications. These devices deliver three 16-bit PWMs with independent timers for applications where high resolution is needed, such as LED lighting, stepper motors, power supplies and other general purpose applications. The core independent peripherals (16-bit PWMs, Complementary Waveform Generator), Enhanced Universal Synchronous Asynchronous Receiver Transceiver (EUSART) and Analog (ADCs, Comparator and DAC) enable closed-loop feedback and communication for use in multiple market segments. The EUSART peripheral enables the communication for applications such as LIN.

### Core Features:

- C Compiler Optimized RISC Architecture
- Only 49 Instructions
- Operating Speed:
  - DC – 32 MHz clock input
  - 125 ns minimum instruction cycle
- Interrupt Capability
- 16-Level Deep Hardware Stack
- Two 8-Bit Timers
- One 16-Bit Timer
- Three Additional 16-Bit Timers available using the 16-Bit PWMs
- Power-on Reset (POR)
- Power-up Timer (PWRT)
- Low-Power Brown-out Reset (LPBOR)
- Programmable Watchdog Timer (WDT) up to 256s
- Programmable Code Protection

### Memory:

- Up to 3.5 Kbytes Flash Program Memory
- Up to 256 Bytes Data SRAM Memory
- Direct, Indirect and Relative Addressing modes
- High-Endurance Flash Data Memory (HEF)
  - 128 bytes if nonvolatile data storage
  - 100k erase/write cycles

### Operating Characteristics:

- Operating Voltage Range:
  - 1.8V to 3.6V (PIC12LF1571/2)
  - 2.3V to 5.5V (PIC12F1571/2)
- Temperature Range:
  - Industrial: -40°C to +85°C
  - Extended: -40°C to +125°C
- Internal Voltage Reference module
- In-Circuit Serial Programming™ (ICSP™) via Two Pins

### eXtreme Low-Power (XLP) Features:

- Sleep mode: 20 nA @ 1.8V, Typical
- Watchdog Timer: 260 nA @ 1.8V, Typical
- Operating Current:
  - 30  $\mu$ A/MHz @ 1.8V, typical

### Digital Peripherals:

- 16-Bit PWM:
  - Three 16-bit PWMs with independent timers
  - Multiple Output modes (Edge-Aligned, Center-Aligned, Set and Toggle on Register Match)
  - User settings for phase, duty cycle, period, offset and polarity
  - 16-bit timer capability
  - Interrupts generated based on timer matches with Offset, Duty Cycle, Period and Phase registers
- Complementary Waveform Generator (CWG):
  - Rising and falling edge dead-band control
  - Multiple signal sources
- Enhanced Universal Synchronous Asynchronous Receiver Transceiver (EUSART):
  - Supports LIN applications

### Device I/O Port Features:

- Six I/Os
- Individually Selectable Weak Pull-ups
- Interrupt-On-Change Pins Option with Edge-Selectable Option

# PIC12(L)F1571/2

## Analog Peripherals:

- 10-Bit Analog-to-Digital Converter (ADC):
  - Up to four external channels
  - Conversion available during Sleep
- Comparator:
  - Low-Power/High-Speed modes
  - Fixed Voltage Reference at (non)inverting input(s)
  - Comparator outputs externally accessible
  - Synchronization with Timer1 clock source
  - Software hysteresis enable
- 5-Bit Digital-to-Analog Converter (DAC):
  - 5-bit resolution, rail-to-rail
  - Positive reference selection
  - Unbuffered I/O pin output
  - Internal connections to ADCs and comparators
- Voltage Reference:
  - Fixed voltage reference with 1.024V, 2.048V and 4.096V output levels

## Clocking Structure:

- Precision Internal Oscillator:
  - Factory calibrated  $\pm 1\%$ , typical
  - Software-selectable clock speeds from 31 kHz to 32 MHz
- External Oscillator Block with:
  - Resonator modes up to 20 MHz
  - Two External Clock modes up to 32 MHz
- Fail-Safe Clock Monitor
- Digital Oscillator Input Available

## PIC12(L)F1571/2 FAMILY TYPES

Device	Data Sheet Index	Program Memory Flash (K words)	Data SRAM (bytes)	High-Endurance Flash (bytes)	I/O Pins	8-Bit/16-Bit Timers	Comparators	16-Bit PWM	10-Bit ADC (ch)	5-Bit DAC	CWG	EUSART	Debug <sup>(1)</sup>	XLP
<a href="#">PIC12(L)F1571</a>	A	1	128	128	6	2/4 <sup>(2)</sup>	1	3	4	1	1	0	I	Y
<a href="#">PIC12(L)F1572</a>	A	2	256	128	6	2/4 <sup>(2)</sup>	1	3	4	1	1	1	I	Y

**Note 1:** I – Debugging integrated on chip.

**2:** Three additional 16-bit timers available when not using the 16-bit PWM outputs.

**Data Sheet Index:** (Unshaded devices are described in this document.)

**A** DS40001723 PIC12(L)F1571/2 Data Sheet, 8-Pin Flash, 8-Bit MCU with High-Precision 16-Bit PWM.

## PIN DIAGRAMS

### Pin Diagram – 8-Pin PDIP, SOIC, DFN, MSOP, UDFN

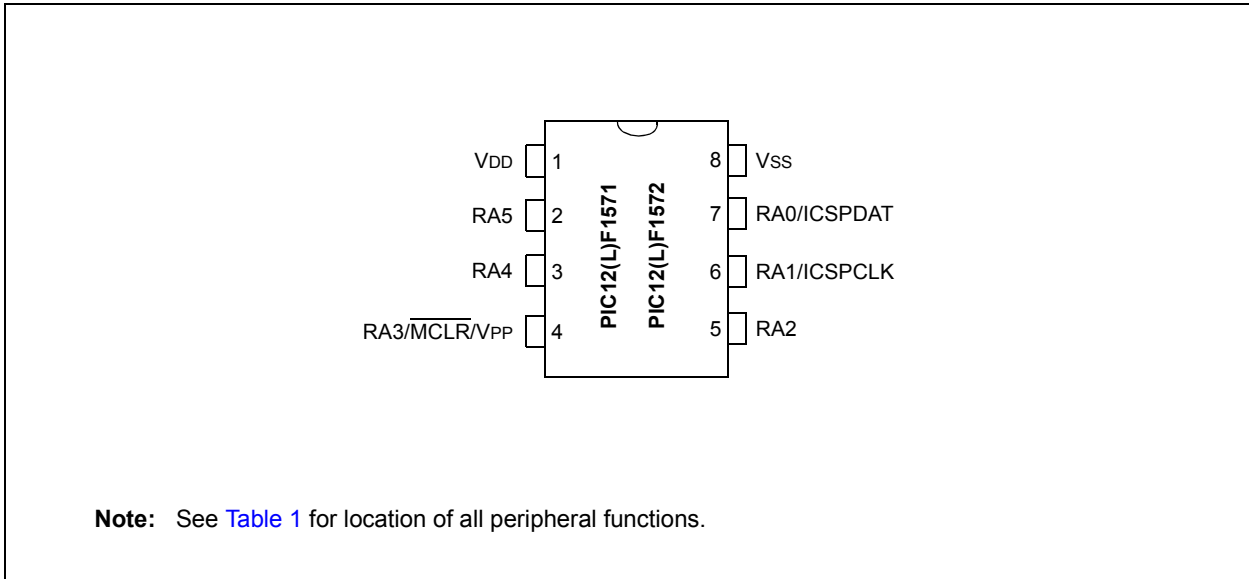

**TABLE 1: 8-PIN ALLOCATION TABLE (PIC12(L)F1571/2)**

I/O	8-Pin PDIP/SOIC/MSOP/DFN/UDFN	ADC	Reference	Comparator	Timers	PWM	EUSART <sup>(2)</sup>	CWG	Interrupt	Pull-up	Basic
RA0	7	AN0	DAC1OUT	C1IN+	—	PWM2	TX <sup>(2)</sup> CK <sup>(2)</sup>	CWG1B	IOC	Y	ICSPDAT ICDDAT
RA1	6	AN1	VREF+	C1IN0-	—	PWM1	RX <sup>(2)</sup> DT <sup>(2)</sup>	—	IOC	Y	ICSPCLK ICDCLK
RA2	5	AN2	—	C1OUT	T0CKI	PWM3	—	$\overline{\text{CWG1FLT}}$ CWG1A	IOC INT	Y	—
RA3	4	—	—	—	T1G <sup>(1)</sup>	—	—	—	IOC	Y	$\overline{\text{MCLR}}$ V <sub>PP</sub>
RA4	3	AN3	—	C1IN1-	T1G	PWM2 <sup>(1)</sup>	TX <sup>(1,2)</sup> CK <sup>(1,2)</sup>	CWG1B <sup>(1)</sup>	IOC	Y	CLKOUT
RA5	2	—	—	—	T1CKI	PWM1 <sup>(1)</sup>	RX <sup>(1,2)</sup> DT <sup>(1,2)</sup>	CWG1A <sup>(1)</sup>	IOC	Y	CLKIN
VDD	1	—	—	—	—	—	—	—	—	—	V <sub>DD</sub>
Vss	8	—	—	—	—	—	—	—	—	—	V <sub>SS</sub>

**Note 1:** Alternate pin function selected with the APFCON ([Register 11-1](#)) register.  
**Note 2:** PIC12(L)F1572 only.

# PIC12(L)F1571/2

---

---

## Table of Contents

1.0	Device Overview .....	7
2.0	Enhanced Mid-Range CPU .....	13
3.0	Memory Organization .....	15
4.0	Device Configuration .....	41
5.0	Oscillator Module.....	47
6.0	Resets .....	59
7.0	Interrupts .....	69
8.0	Power-Down Mode (Sleep) .....	83
9.0	Watchdog Timer (WDT) .....	87
10.0	Flash Program Memory Control .....	91
11.0	I/O Ports .....	109
12.0	Interrupt-On-Change .....	119
13.0	Fixed Voltage Reference (FVR) .....	123
14.0	Temperature Indicator Module .....	127
15.0	Analog-to-Digital Converter (ADC) Module .....	129
16.0	5-Bit Digital-to-Analog Converter (DAC) Module .....	143
17.0	Comparator Module.....	147
18.0	Timer0 Module .....	155
19.0	Timer1 Module with Gate Control.....	159
20.0	Timer2 Module .....	171
21.0	Enhanced Universal Synchronous Asynchronous Receiver Transmitter (EUSART) .....	175
22.0	16-Bit Pulse-Width Modulation (PWM) Module .....	203
23.0	Complementary Waveform Generator (CWG) Module .....	231
24.0	In-Circuit Serial Programming™ (ICSP™) .....	243
25.0	Instruction Set Summary .....	245
26.0	Electrical Specifications.....	259
27.0	DC and AC Characteristics Graphs and Charts .....	283
28.0	Development Support.....	305
29.0	Packaging Information.....	309
Appendix A: Data Sheet Revision History .....		327
The Microchip Web Site .....		329
Customer Change Notification Service .....		329
Customer Support .....		329
Product Identification System.....		331

## TO OUR VALUED CUSTOMERS

It is our intention to provide our valued customers with the best documentation possible to ensure successful use of your Microchip products. To this end, we will continue to improve our publications to better suit your needs. Our publications will be refined and enhanced as new volumes and updates are introduced.

If you have any questions or comments regarding this publication, please contact the Marketing Communications Department via E-mail at [docerrors@microchip.com](mailto:docerrors@microchip.com). We welcome your feedback.

### Most Current Data Sheet

To obtain the most up-to-date version of this data sheet, please register at our Worldwide Web site at:

<http://www.microchip.com>

You can determine the version of a data sheet by examining its literature number found on the bottom outside corner of any page. The last character of the literature number is the version number, (e.g., DS30000000A is version A of document DS30000000).

### Errata

An errata sheet, describing minor operational differences from the data sheet and recommended workarounds, may exist for current devices. As device/documentation issues become known to us, we will publish an errata sheet. The errata will specify the revision of silicon and revision of document to which it applies.

To determine if an errata sheet exists for a particular device, please check with one of the following:

- Microchip's Worldwide Web site; <http://www.microchip.com>
- Your local Microchip sales office (see last page)

When contacting a sales office, please specify which device, revision of silicon and data sheet (include literature number) you are using.

### Customer Notification System

Register on our web site at [www.microchip.com](http://www.microchip.com) to receive the most current information on all of our products.

# PIC12(L)F1571/2

---

NOTES:

## 1.0 DEVICE OVERVIEW

The PIC12(L)F1571/2 devices are described within this data sheet. The block diagram of these devices is shown in [Figure 1-1](#), the available peripherals are shown in [Table 1-1](#) and the pinout descriptions are shown in [Table 1-2](#).

**TABLE 1-1: DEVICE PERIPHERAL SUMMARY**

Peripheral	PIC12(L)F1571	PIC12(L)F1572
Analog-to-Digital Converter (ADC)	•	•
Complementary Wave Generator (CWG)	•	•
Digital-to-Analog Converter (DAC)	•	•
Enhanced Universal Synchronous/Asynchronous Receiver/Transmitter (EUSART)		•
Fixed Voltage Reference (FVR)	•	•
Temperature Indicator	•	•
Comparators		
	C1	•
PWM Modules		
	PWM1	•
	PWM2	•
	PWM3	•
Timers		
	Timer0	•
	Timer1	•
	Timer2	•

## 1.1 Register and Bit Naming Conventions

### 1.1.1 REGISTER NAMES

When there are multiple instances of the same peripheral in a device, the peripheral control registers will be depicted as the concatenation of a peripheral identifier, peripheral instance and control identifier. The control registers section will show just one instance of all the register names with an 'x' in the place of the peripheral instance number. This naming convention may also be applied to peripherals when there is only one instance of that peripheral in the device to maintain compatibility with other devices in the family that contain more than one.

### 1.1.2 BIT NAMES

There are two variants for bit names:

- Short name: Bit function abbreviation
- Long name: Peripheral abbreviation + short name

#### 1.1.2.1 Short Bit Names

Short bit names are an abbreviation for the bit function. For example, some peripherals are enabled with the EN bit. The bit names shown in the registers are the short name variant.

Short bit names are useful when accessing bits in C programs. The general format for accessing bits by the short name is *RegisterNamebits.ShortName*. For example, the enable bit, EN, in the COG1CON0 register can be set in C programs with the instruction, `COG1CON0bits.EN = 1`.

Short names are generally not useful in assembly programs because the same name may be used by different peripherals in different bit positions. When this occurs, during the include file generation, all instances of that short bit name are appended with an underscore, plus the name of the register in which the bit resides, to avoid naming contentions.

# PIC12(L)F1571/2

---

## 1.1.2.2 Long Bit Names

Long bit names are constructed by adding a peripheral abbreviation prefix to the short name. The prefix is unique to the peripheral, thereby making every long bit name unique. The long bit name for the COG1 enable bit is the COG1 prefix, G1, appended with the enable bit short name, EN, resulting in the unique bit name G1EN.

Long bit names are useful in both C and assembly programs. For example, in C, the COG1CON0 enable bit can be set with the `G1EN = 1` instruction. In assembly, this bit can be set with the `BSF COG1CON0,G1EN` instruction.

## 1.1.2.3 Bit Fields

Bit fields are two or more adjacent bits in the same register. Bit fields adhere only to the short bit naming convention. For example, the three Least Significant bits of the COG1CON0 register contain the mode control bits. The short name for this field is MD. There is no long bit name variant. Bit field access is only possible in C programs. The following example demonstrates a C program instruction for setting the COG1 to the Push-Pull mode:

```
COG1CON0bits.MD = 0x5;
```

Individual bits in a bit field can also be accessed with long and short bit names. Each bit is the field name appended with the number of the bit position within the field. For example, the Most Significant mode bit has the short bit name, MD2, and the long bit name is G1MD2. The following two examples demonstrate assembly program sequences for setting the COG1 to Push-Pull mode:

### Example 1:

```
MOVLW ~(1<<G1MD1)
ANDWF COG1CON0,F
MOVLW 1<<G1MD2 | 1<<G1MD0
IORWF COG1CON0,F
```

### Example 2:

```
BSF COG1CON0,G1MD2
BCF COG1CON0,G1MD1
BSF COG1CON0,G1MD0
```

## 1.1.3 REGISTER AND BIT NAMING EXCEPTIONS

### 1.1.3.1 Status, Interrupt and Mirror Bits

Status, interrupt enables, interrupt flags and mirror bits are contained in registers that span more than one peripheral. In these cases, the bit name shown is unique so there is no prefix or short name variant.

### 1.1.3.2 Legacy Peripherals

There are some peripherals that do not strictly adhere to these naming conventions. Peripherals that have existed for many years and are present in almost every device are the exceptions. These exceptions were necessary to limit the adverse impact of the new conventions on legacy code. Peripherals that do adhere to the new convention will include a table in the registers section indicating the long name prefix for each peripheral instance. Peripherals that fall into the exception category will not have this table. These peripherals include, but are not limited to, the following:

- EUSART
- MSSP



FIGURE 1-1: PIC12(L)F1571/2 BLOCK DIAGRAM

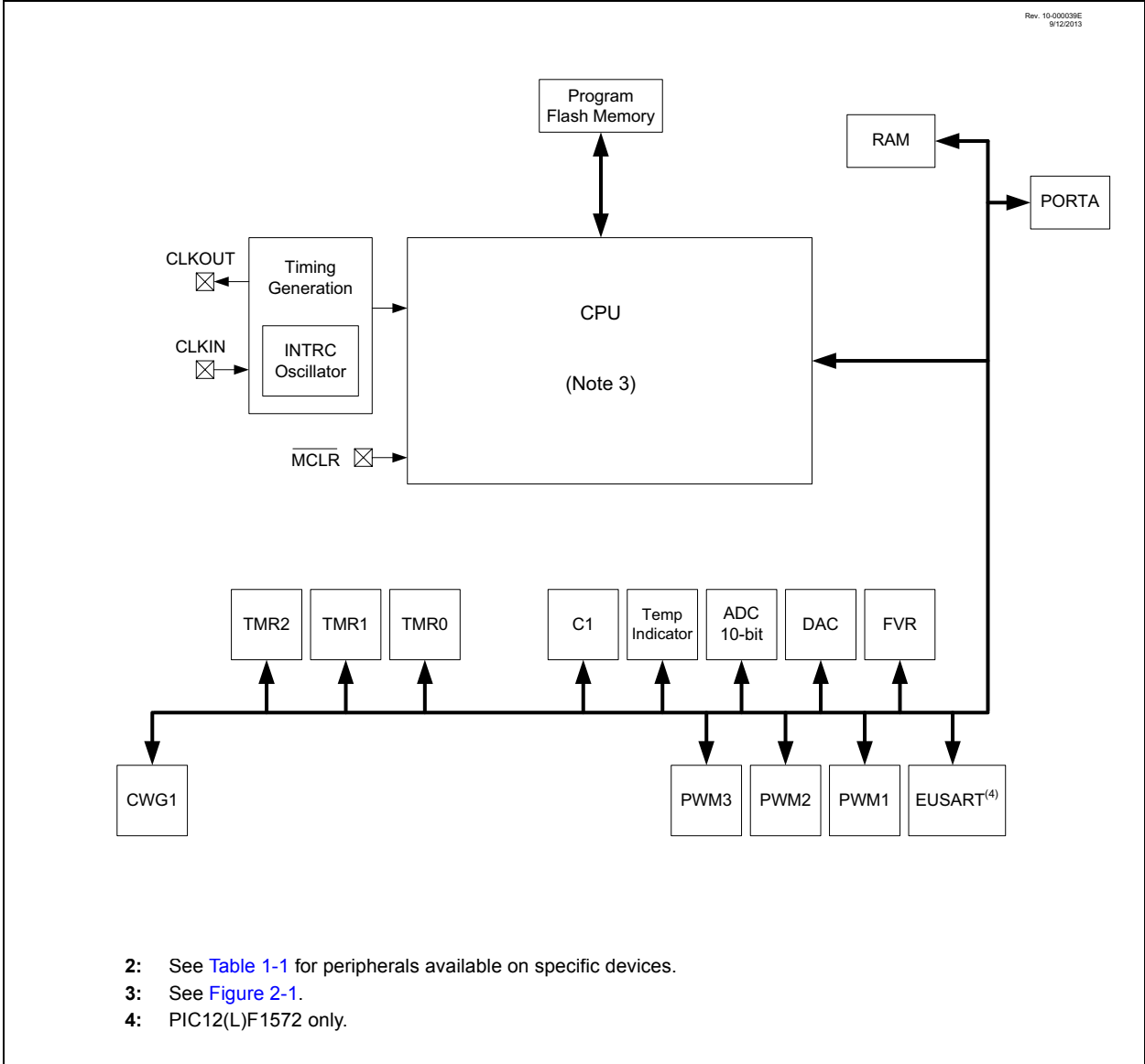

2: See Table 1-1 for peripherals available on specific devices.  
3: See Figure 2-1.  
4: PIC12(L)F1572 only.

# PIC12(L)F1571/2

**TABLE 1-2: PIC12(L)F1571/2 PINOUT DESCRIPTION**

Name	Function	Input Type	Output Type	Description
RA0/AN0/C1IN+/DACOUT/ TX <sup>(2)</sup> /CK <sup>(2)</sup> /CWG1B/PWM2/ ICSPDAT/ICDDAT	RA0	(3)	(4)	General purpose I/O.
	AN0			ADC channel input.
	C1IN+			Comparator positive input.
	DACOUT			Digital-to-Analog Converter output.
	TX			USART asynchronous transmit.
	CK			USART synchronous clock.
	CWG1B			CWG complementary output.
	PWM2			PWM output.
	ICSPDAT			ICSP™ data I/O.
	ICDDAT			In-circuit debug data.
RA1/AN1/VREF+/C1IN0-/RX <sup>(2)</sup> / DT <sup>(2)</sup> /PWM1/ICSPCLK/ICDCLK	RA1	(3)	(4)	General purpose I/O.
	AN1			ADC channel input.
	VREF+			ADC Voltage Reference input.
	C1IN0-			Comparator negative input.
	RX			USART asynchronous input.
	DT			USART synchronous data.
	PWM1			PWM output.
	ICSPCLK			ICSP programming clock.
	ICDCLK			In-circuit debug clock.
	RA2/AN2/C1OUT/T0CKI/ CWG1FLT/CWG1A/PWM3/INT			RA2
AN2		ADC channel input.		
C1OUT		Comparator output.		
T0CKI		Timer0 clock input.		
CWG1FLT		Complementary Waveform Generator Fault input.		
CWG1A		CWG complementary output.		
PWM3		PWM output.		
INT		External interrupt.		
RA3/VPP/T1G <sup>(1)</sup> /MCLR	RA3	(3)	(4)	General purpose input with IOC and WPU.
	VPP			Programming voltage.
	T1G			Timer1 gate input.
	MCLR			Master Clear with internal pull-up.
RA4/AN3/C1IN1-/T1G/TX <sup>(1,2)</sup> / CK <sup>(1,2)</sup> /CWG1B <sup>(1)</sup> /PWM2 <sup>(1)</sup> / CLKOUT	RA4	(3)	(4)	General purpose I/O.
	AN3			ADC channel input.
	C1IN1-			Comparator negative input.
	T1G			Timer1 gate input.
	TX			USART asynchronous transmit.
	CK			USART synchronous clock.
	CWG1B			CWG complementary output.
	PWM2			PWM output.
	CLKOUT			Fosc/4 output.

**Legend:** AN = Analog input or output    CMOS = CMOS compatible input or output    OD = Open-Drain  
TTL = TTL compatible input    ST = Schmitt Trigger input with CMOS levels    I<sup>2</sup>C = Schmitt Trigger input with I<sup>2</sup>C levels  
HV = High Voltage    XTAL = Crystal

- Note** 1: Alternate pin function selected with the APFCON (Register 11-1) register.  
2: PIC12(L)F1572 only.  
3: Input type is selected by the port.  
4: Output type is selected by the port.

**TABLE 1-2: PIC12(L)F1571/2 PINOUT DESCRIPTION (CONTINUED)**

Name	Function	Input Type	Output Type	Description
RA5/T1CKI/RX <sup>(1,2)</sup> /DT <sup>(1,2)</sup> / CWG1A <sup>(1)</sup> /PWM1 <sup>(1)</sup> /CLKIN	RA5	(3)	(4)	General purpose I/O.
	T1CKI			Timer1 clock input.
	RX			USART asynchronous input.
	DT			USART synchronous data.
	CWG1A			CWG complementary output.
	PWM1			PWM output.
	CLKIN			External Clock input (EC mode).
VDD	VDD	Power	—	Positive supply.
VSS	VSS	Power	—	Ground reference.

**Legend:** AN = Analog input or output    CMOS = CMOS compatible input or output    OD = Open-Drain  
TTL = TTL compatible input    ST = Schmitt Trigger input with CMOS levels    I<sup>2</sup>C = Schmitt Trigger input with I<sup>2</sup>C levels  
HV = High Voltage    XTAL = Crystal

- Note** 1: Alternate pin function selected with the APFCON ([Register 11-1](#)) register.  
2: PIC12(L)F1572 only.  
3: Input type is selected by the port.  
4: Output type is selected by the port.

# PIC12(L)F1571/2

---

NOTES:

## 2.0 ENHANCED MID-RANGE CPU

This family of devices contains an enhanced mid-range 8-bit CPU core. The CPU has 49 instructions. Interrupt capability includes automatic context saving. The hardware stack is 16 levels deep and has Overflow and Underflow Reset capability. Direct, Indirect and Relative Addressing modes are available. Two File Select Registers (FSRs) provide the ability to read program and data memory.

- Automatic Interrupt Context Saving
- 16-Level Stack with Overflow and Underflow
- File Select Registers
- Instruction Set

**FIGURE 2-1: CORE BLOCK DIAGRAM**

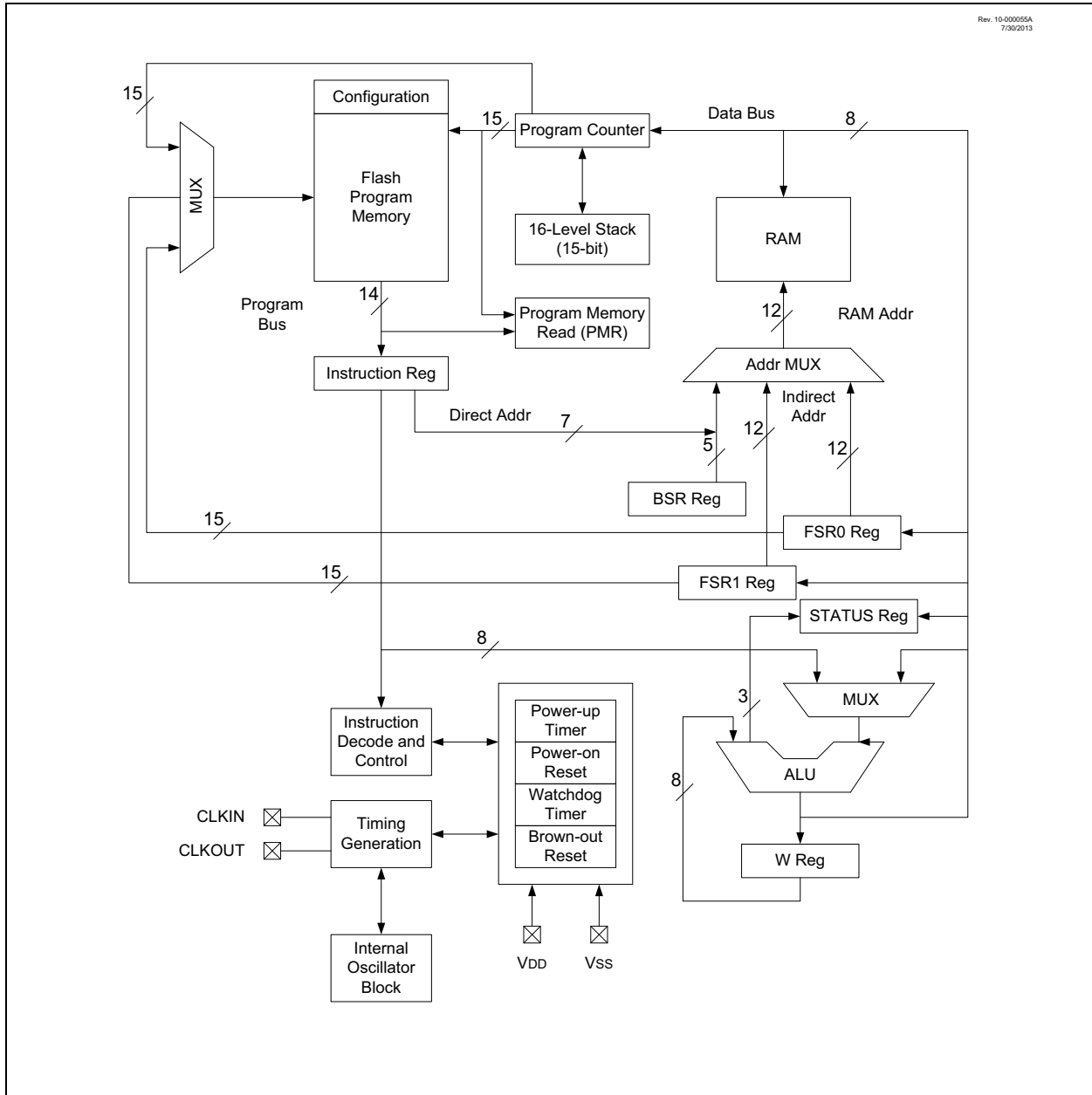

# PIC12(L)F1571/2

---

## 2.1 Automatic Interrupt Context Saving

During interrupts, certain registers are automatically saved in shadow registers and restored when returning from the interrupt. This saves stack space and user code. See [Section 7.5 “Automatic Context Saving”](#), for more information.

## 2.2 16-Level Stack with Overflow and Underflow

These devices have a hardware stack memory, 15 bits wide and 16 words deep. A Stack Overflow or Underflow will set the appropriate bit (STKOVF or STKUNF) in the PCON register, and if enabled, will cause a Software Reset. See [Section 3.5 “Stack”](#) for more details.

## 2.3 File Select Registers

There are two 16-bit File Select Registers (FSR). FSRs can access all file registers and program memory, which allows one Data Pointer for all memory. When an FSR points to program memory, there is one additional instruction cycle in instructions using INDF to allow the data to be fetched. General purpose memory can now also be addressed linearly, providing the ability to access contiguous data larger than 80 bytes. There are also new instructions to support the FSRs. See [Section 3.6 “Indirect Addressing”](#) for more details.

## 2.4 Instruction Set

There are 49 instructions for the enhanced mid-range CPU to support the features of the CPU. See [Section 25.0 “Instruction Set Summary”](#) for more details.

## 3.0 MEMORY ORGANIZATION

These devices contain the following types of memory:

- Program Memory:
  - Configuration Words
  - Device ID
  - User ID
  - Flash Program Memory
- Data Memory:
  - Core Registers
  - Special Function Registers
  - General Purpose RAM
  - Common RAM

The following features are associated with access and control of program memory and data memory:

- PCL and PCLATH
- Stack
- Indirect Addressing

## 3.1 Program Memory Organization

The enhanced mid-range core has a 15-bit Program Counter (PC) capable of addressing a 32K x 14 program memory space. [Table 3-1](#) shows the memory sizes implemented. Accessing a location above these boundaries will cause a wraparound within the implemented memory space. The Reset vector is at 0000h and the interrupt vector is at 0004h (see [Figure 3-1](#)).

## 3.2 High-Endurance Flash

This device has a 128-byte section of high-endurance Program Flash Memory (PFM) in lieu of data EEPROM. This area is especially well-suited for non-volatile data storage that is expected to be updated frequently over the life of the end product. See [Section 10.2 “Flash Program Memory Overview”](#) for more information on writing data to PFM. See [Section 3.2.1.2 “Indirect Read with FSR”](#) for more information about using the FSR registers to read byte data stored in PFM.

**TABLE 3-1: DEVICE SIZES AND ADDRESSES**

Device	Program Memory Space (Words)	Last Program Memory Address	High-Endurance Flash Memory Address Range <sup>(1)</sup>
PIC12(L)F1571	1,024	03FFh	0380h-03FFh
PIC12(L)F1572	2,048	07FFh	0780h-07FFh

**Note 1:** High-endurance Flash applies to the low byte of each address in the range.

# PIC12(L)F1571/2

**FIGURE 3-1: PROGRAM MEMORY MAP AND STACK FOR PIC12(L)F1571**

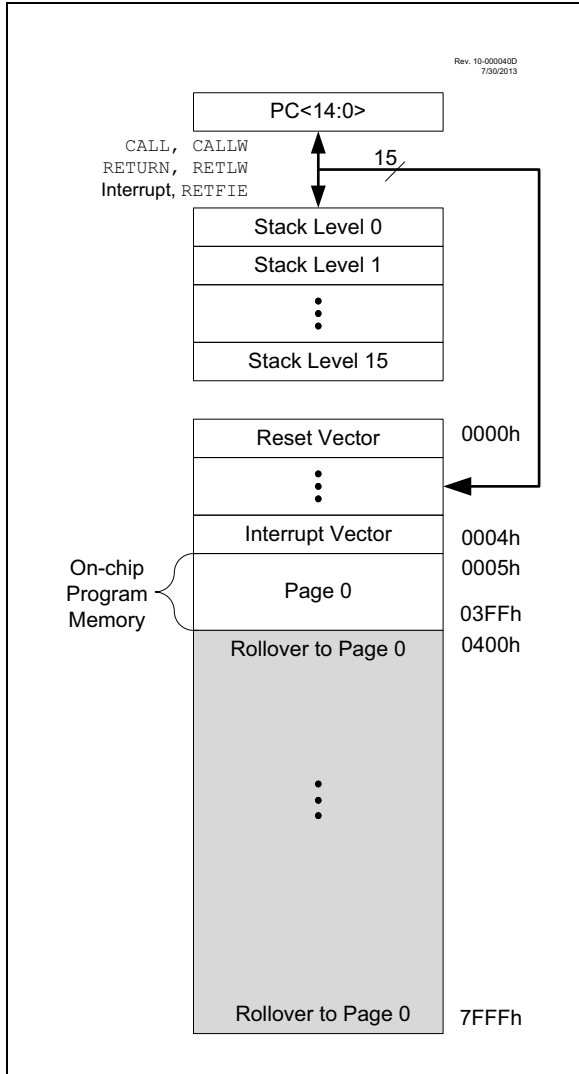

**FIGURE 3-2: PROGRAM MEMORY MAP AND STACK FOR PIC12(L)F1572**

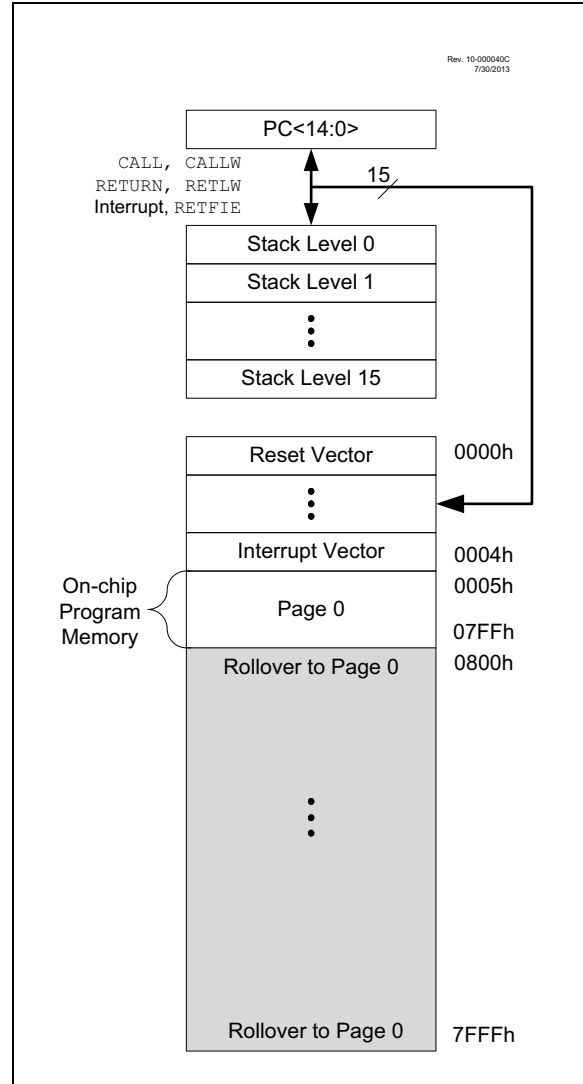



## 3.2.1 READING PROGRAM MEMORY AS DATA

There are two methods of accessing constants in program memory. The first method is to use tables of RETLW instructions. The second method is to set an FSR to point to the program memory.

### 3.2.1.1 RETLW Instruction

The RETLW instruction can be used to provide access to tables of constants. The recommended way to create such a table is shown in [Example 3-1](#).

#### EXAMPLE 3-1: RETLW INSTRUCTION

```
constants
    BRW          ;Add Index in W to
                ;program counter to
                ;select data
    RETLW DATA0 ;Index0 data
    RETLW DATA1 ;Index1 data
    RETLW DATA2
    RETLW DATA3

my_function
    ;... LOTS OF CODE...
    MOVLW      DATA_INDEX
    call constants
    ;... THE CONSTANT IS IN W
```

The BRW instruction makes this type of table very simple to implement. If your code must remain portable with previous generations of microcontrollers, then the BRW instruction is not available, so the older table read method must be used.

### 3.2.1.2 Indirect Read with FSR

The program memory can be accessed as data by setting bit 7 of the FSRnH register and reading the matching INDFn register. The MOVLW instruction will place the lower eight bits of the addressed word in the W register. Writes to the program memory cannot be performed via the INDFn registers. Instructions that access the program memory via the FSR require one extra instruction cycle to complete. [Example 3-2](#) demonstrates accessing the program memory via an FSR.

The HIGH operator will set bit<7> if a label points to a location in program memory.

#### EXAMPLE 3-2: ACCESSING PROGRAM MEMORY VIA FSR

```
constants
    DW DATA0 ;First constant
    DW DATA1 ;Second constant
    DW DATA2
    DW DATA3

my_function
    ;... LOTS OF CODE...
    MOVLW DATA_INDEX
    ADDLW LOW constants
    MOVWF FSR1L
    MOVLW HIGH constants ;MSb is set
                        ;automatically

    MOVWF FSR1H
    BTFSC STATUS,C ;carry from ADDLW?
    INCF FSR1H,f ;yes
    MOVLW 0[FSR1]
    ;THE PROGRAM MEMORY IS IN W
```

# PIC12(L)F1571/2

## 3.3 Data Memory Organization

The data memory is partitioned in 32 memory banks with 128 bytes in a bank. Each bank consists of (Figure 3-3):

- 12 Core Registers
- 20 Special Function Registers (SFR)
- Up to 80 bytes of General Purpose RAM (GPR)
- 16 bytes of Common RAM

The active bank is selected by writing the bank number into the Bank Select Register (BSR). Unimplemented memory will read as '0'. All data memory can be accessed either directly (via instructions that use the file registers) or indirectly via the two File Select Registers (FSR). See Section 3.6 "Indirect Addressing" for more information.

Data memory uses a 12-bit address. The upper five bits of the address define the bank address and the lower seven bits select the registers/RAM in that bank.

### 3.3.1 CORE REGISTERS

The core registers contain the registers that directly affect the basic operation. The core registers occupy the first 12 addresses of every data memory bank (addresses: x00h/x08h through x0Bh/x8Bh). These registers are listed below in Table 3-2. For detailed information, see Table 3-9.

**TABLE 3-2: CORE REGISTERS**

Addresses	BANKx
x00h or x80h	INDF0
x01h or x81h	INDF1
x02h or x82h	PCL
x03h or x83h	STATUS
x04h or x84h	FSR0L
x05h or x85h	FSR0H
x06h or x86h	FSR1L
x07h or x87h	FSR1H
x08h or x88h	BSR
x09h or x89h	WREG
x0Ah or x8Ah	PCLATH
x0Bh or x8Bh	INTCON

## 3.3.1.1 STATUS Register

The STATUS register, shown in [Register 3-1](#), contains:

- The arithmetic status of the ALU
- The Reset status

The STATUS register can be the destination for any instruction, like any other register. If the STATUS register is the destination for an instruction that affects the Z, DC or C bits, then the write to these three bits is disabled. These bits are set or cleared according to the device logic. Furthermore, the  $\overline{TO}$  and  $\overline{PD}$  bits are not writable. Therefore, the result of an instruction with the STATUS register as destination may be different than intended.

For example, `CLRF STATUS` will clear the upper three bits and set the Z bit. This leaves the STATUS register as '000u u1uu' (where u = unchanged).

It is recommended, therefore, that only `BCF`, `BSF`, `SWAPF` and `MOVWF` instructions are used to alter the STATUS register, because these instructions do not affect any Status bits. For other instructions not affecting any Status bits, refer to [Section 25.0 "Instruction Set Summary"](#).

**Note 1:** The  $\overline{C}$  and  $\overline{DC}$  bits operate as Borrow and Digit Borrow out bits, respectively, in subtraction.

**REGISTER 3-1: STATUS: STATUS REGISTER**

U-0	U-0	U-0	R-1/q	R-1/q	R/W-0/u	R/W-0/u	R/W-0/u
—	—	—	$\overline{TO}$	$\overline{PD}$	Z	DC <sup>(1)</sup>	C <sup>(1)</sup>
bit 7							bit 0

**Legend:**

R = Readable bit	W = Writable bit	U = Unimplemented bit, read as '0'
u = Bit is unchanged	x = Bit is unknown	-n/n = Value at POR and BOR/Value at all other Resets
'1' = Bit is set	'0' = Bit is cleared	q = Value depends on condition

- bit 7-5     **Unimplemented:** Read as '0'
- bit 4      **$\overline{TO}$ :** Time-out bit  
           1 = After power-up, `CLRWDT` instruction or `SLEEP` instruction  
           0 = A WDT time-out occurred
- bit 3      **$\overline{PD}$ :** Power-Down bit  
           1 = After power-down or by the `CLRWDT` instruction  
           0 = By execution of the `SLEEP` instruction
- bit 2     **Z:** Zero bit  
           1 = The result of an arithmetic or logic operation is zero  
           0 = The result of an arithmetic or logic operation is not zero
- bit 1     **DC:** Digit Carry/Digit Borrow bit (`ADDWF`, `ADDLW`, `SUBLW`, `SUBWF` instructions)<sup>(1)</sup>  
           1 = A carry-out from the 4th low-order bit of the result occurred  
           0 = No carry-out from the 4th low-order bit of the result
- bit 0     **C:** Carry/Borrow bit<sup>(1)</sup> (`ADDWF`, `ADDLW`, `SUBLW`, `SUBWF` instructions)<sup>(1)</sup>  
           1 = A carry-out from the Most Significant bit of the result occurred  
           0 = No carry-out from the Most Significant bit of the result occurred

**Note 1:** For Borrow, the polarity is reversed. A subtraction is executed by adding the two's complement of the second operand. For rotate (`RRF`, `RLF`) instructions, this bit is loaded with either the high-order or low-order bit of the source register.

# PIC12(L)F1571/2

## 3.3.2 SPECIAL FUNCTION REGISTER

The Special Function Registers are registers used by the application to control the desired operation of peripheral functions in the device. The Special Function Registers occupy the 20 bytes after the core registers of every data memory bank (addresses: x0Ch/x8Ch through x1Fh/x9Fh). The registers associated with the operation of the peripherals are described in the appropriate peripheral chapter of this data sheet.

## 3.3.3 GENERAL PURPOSE RAM

There are up to 80 bytes of GPR in each data memory bank. The Special Function Registers occupy the 20 bytes after the core registers of every data memory bank (addresses: x0Ch/x8Ch through x1Fh/x9Fh).

### 3.3.3.1 Linear Access to GPR

The general purpose RAM can be accessed in a non-banked method via the FSRs. This can simplify access to large memory structures. See [Section 3.6.2 “Linear Data Memory”](#) for more information.

## 3.3.4 COMMON RAM

There are 16 bytes of common RAM accessible from all banks.

## 3.3.5 DEVICE MEMORY MAPS

The memory maps for PIC12(L)F1571/2 are as shown in [Table 3-3](#) through [Table 3-8](#).

**FIGURE 3-3: BANKED MEMORY PARTITIONING**

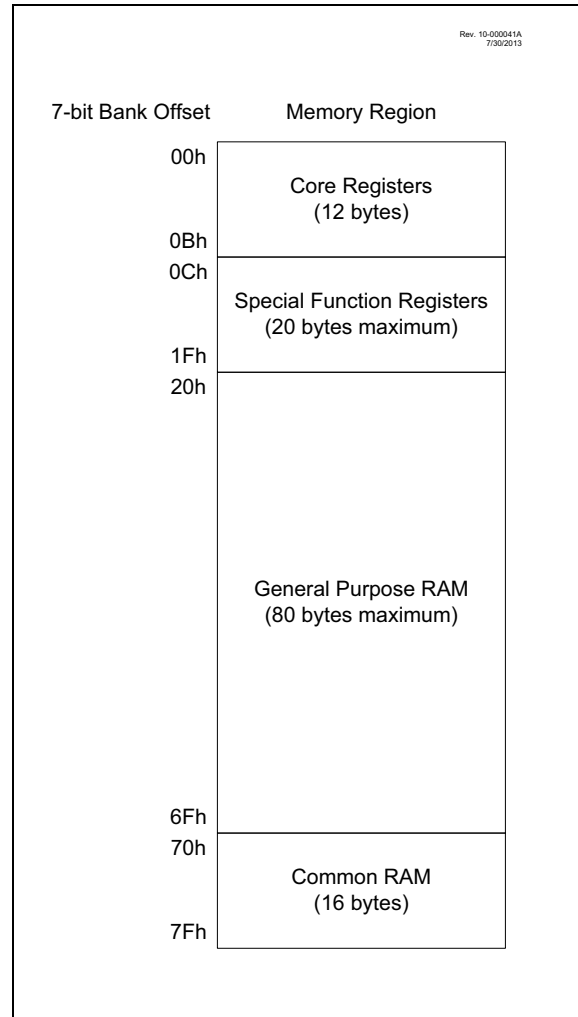

**TABLE 3-3: PIC12(L)F1571 MEMORY MAP, BANK 0-7**

BANK 0		BANK 1		BANK 2		BANK 3		BANK 4		BANK 5		BANK 6		BANK 7	
000h	Core Registers (Table 3-2)	080h	Core Registers (Table 3-2)	100h	Core Registers (Table 3-2)	180h	Core Registers (Table 3-2)	200h	Core Registers (Table 3-2)	280h	Core Registers (Table 3-2)	300h	Core Registers (Table 3-2)	380h	Core Registers (Table 3-2)
00Bh		08Bh		10Bh		18Bh		20Bh		28Bh		30Bh		38Bh	
00Ch	PORTA	08Ch	TRISA	10Ch	LATA	18Ch	ANSELA	20Ch	WPUA	28Ch	ODCONA	30Ch	SLRCONA	38Ch	INLVLA
00Dh	—	08Dh	—	10Dh	—	18Dh	—	20Dh	—	28Dh	—	30Dh	—	38Dh	—
00Eh	—	08Eh	—	10Eh	—	18Eh	—	20Eh	—	28Eh	—	30Eh	—	38Eh	—
00Fh	—	08Fh	—	10Fh	—	18Fh	—	20Fh	—	28Fh	—	30Fh	—	38Fh	—
010h	—	090h	—	110h	—	190h	—	210h	—	290h	—	310h	—	390h	—
011h	PIR1	091h	PIE1	111h	CM1CON0	191h	PMADRL	211h	—	291h	—	311h	—	391h	IOCAP
012h	PIR2	092h	PIE2	112h	CM1CON1	192h	PMADRH	212h	—	292h	—	312h	—	392h	IOCAN
013h	PIR3	093h	PIE3	113h	—	193h	PMDATL	213h	—	293h	—	313h	—	393h	IOCAF
014h	—	094h	—	114h	—	194h	PMDATH	214h	—	294h	—	314h	—	394h	—
015h	TMR0	095h	OPTION_REG	115h	CMOUT	195h	PMCON1	215h	—	295h	—	315h	—	395h	—
016h	TMR1L	096h	PCON	116h	BORCON	196h	PMCON2	216h	—	296h	—	316h	—	396h	—
017h	TMR1H	097h	WDTCON	117h	FVRCON	197h	VREGCON <sup>(1)</sup>	217h	—	297h	—	317h	—	397h	—
018h	T1CON	098h	OSCTUN E	118h	DACxCON0	198h	—	218h	—	298h	—	318h	—	398h	—
019h	T1GCON	099h	OSCCON	119h	DACxCON1	199h	—	219h	—	299h	—	319h	—	399h	—
01Ah	TMR2	09Ah	OSCSTAT	11Ah	—	19Ah	—	21Ah	—	29Ah	—	31Ah	—	39Ah	—
01Bh	PR2	09Bh	ADRESL	11Bh	—	19Bh	—	21Bh	—	29Bh	—	31Bh	—	39Bh	—
01Ch	T2CON	09Ch	ADRESH	11Ch	—	19Ch	—	21Ch	—	29Ch	—	31Ch	—	39Ch	—
01Dh	—	09Dh	ADCON0	11Dh	APFCON	19Dh	—	21Dh	—	29Dh	—	31Dh	—	39Dh	—
01Eh	—	09Eh	ADCON1	11Eh	—	19Eh	—	21Eh	—	29Eh	—	31Eh	—	39Eh	—
01Fh	—	09Fh	ADCON2	11Fh	—	19Fh	—	21Fh	—	29Fh	—	31Fh	—	39Fh	—
020h	General Purpose Register 80 Bytes	0A0h	General Purpose Register 48 Bytes	120h	Unimplemented Read as '0'	1A0h	Unimplemented Read as '0'	220h	Unimplemented Read as '0'	2A0h	Unimplemented Read as '0'	320h	Unimplemented Read as '0'	3A0h	Unimplemented Read as '0'
		0BFh		0C0h		Unimplemented Read as '0'									
06Fh	Common RAM	0EFh	Common RAM (Accesses 70h-7Fh)	16Fh	Common RAM (Accesses 70h-7Fh)	1EFh	Common RAM (Accesses 70h-7Fh)	26Fh	Common RAM (Accesses 70h-7Fh)	2EFh	Common RAM (Accesses 70h-7Fh)	36Fh	Common RAM (Accesses 70h-7Fh)	3EFh	Common RAM (Accesses 70h-7Fh)
070h		0F0h		170h		1F0h		270h		2F0h		370h		3F0h	
07Fh		0FFh		17Fh		1FFh		27Fh		2FFh		37Fh		3FFh	

Legend:  = Unimplemented data memory locations, read as '0'.

Note 1: PIC12F1571 only.

TABLE 3-4: PIC12(L)F1572 MEMORY MAP, BANK 0-7

BANK 0		BANK 1		BANK 2		BANK 3		BANK 4		BANK 5		BANK 6		BANK 7	
000h	Core Registers (Table 3-2)	080h	Core Registers (Table 3-2)	100h	Core Registers (Table 3-2)	180h	Core Registers (Table 3-2)	200h	Core Registers (Table 3-2)	280h	Core Registers (Table 3-2)	300h	Core Registers (Table 3-2)	380h	Core Registers (Table 3-2)
00Bh		08Bh		10Bh		18Bh		20Bh		28Bh		30Bh		38Bh	
00Ch	PORTA	08Ch	TRISA	10Ch	LATA	18Ch	ANSELA	20Ch	WPUA	28Ch	ODCONA	30Ch	SLRCONA	38Ch	INLVLA
00Dh	—	08Dh	—	10Dh	—	18Dh	—	20Dh	—	28Dh	—	30Dh	—	38Dh	—
00Eh	—	08Eh	—	10Eh	—	18Eh	—	20Eh	—	28Eh	—	30Eh	—	38Eh	—
00Fh	—	08Fh	—	10Fh	—	18Fh	—	20Fh	—	28Fh	—	30Fh	—	38Fh	—
010h	—	090h	—	110h	—	190h	—	210h	—	290h	—	310h	—	390h	—
011h	PIR1	091h	PIE1	111h	CM1CON0	191h	PMADRL	211h	—	291h	—	311h	—	391h	IOCAP
012h	PIR2	092h	PIE2	112h	CM1CON1	192h	PMADRH	212h	—	292h	—	312h	—	392h	IOCAN
013h	PIR3	093h	PIE3	113h	—	193h	PMDATL	213h	—	293h	—	313h	—	393h	IOCAF
014h	—	094h	—	114h	—	194h	PMDATH	214h	—	294h	—	314h	—	394h	—
015h	TMR0	095h	OPTION_REG	115h	CMOUT	195h	PMCON1	215h	—	295h	—	315h	—	395h	—
016h	TMR1L	096h	PCON	116h	BORCON	196h	PMCON2	216h	—	296h	—	316h	—	396h	—
017h	TMR1H	097h	WDTCON	117h	FVRCON	197h	VREGCON <sup>(1)</sup>	217h	—	297h	—	317h	—	397h	—
018h	T1CON	098h	OSCTUNE	118h	DAC1CON0	198h	—	218h	—	298h	—	318h	—	398h	—
019h	T1GCON	099h	OSCCON	119h	DAC1CON1	199h	RCREG	219h	—	299h	—	319h	—	399h	—
01Ah	TMR2	09Ah	OSCSTAT	11Ah	—	19Ah	TXREG	21Ah	—	29Ah	—	31Ah	—	39Ah	—
01Bh	PR2	09Bh	ADRESL	11Bh	—	19Bh	SPBRG	21Bh	—	29Bh	—	31Bh	—	39Bh	—
01Ch	T2CON	09Ch	ADRESH	11Ch	—	19Ch	SPBRGH	21Ch	—	29Ch	—	31Ch	—	39Ch	—
01Dh	—	09Dh	ADCON0	11Dh	APFCON	19Dh	RCSTA	21Dh	—	29Dh	—	31Dh	—	39Dh	—
01Eh	—	09Eh	ADCON1	11Eh	—	19Eh	TXSTA	21Eh	—	29Eh	—	31Eh	—	39Eh	—
01Fh	—	09Fh	ADCON2	11Fh	—	19Fh	BAUDCON	21Fh	—	29Fh	—	31Fh	—	39Fh	—
020h	General Purpose Register 80 Bytes	0A0h	General Purpose Register 80 Bytes	120h	General Purpose Register 80 Bytes	1A0h	Unimplemented Read as '0'	220h	Unimplemented Read as '0'	2A0h	Unimplemented Read as '0'	320h	Unimplemented Read as '0'	3A0h	Unimplemented Read as '0'
06Fh		0EFh		16Fh		1EFh		26Fh		2EFh		36Fh		3EFh	
070h	Common RAM	0F0h	Accesses 70h-7Fh	170h	Accesses 70h-7Fh	1F0h	Accesses 70h-7Fh	270h	Accesses 70h-7Fh	2F0h	Accesses 70h-7Fh	370h	Accesses 70h-7Fh	3F0h	Accesses 70h-7Fh
07Fh		0FFh		17Fh		1FFh		27Fh		2FFh		37Fh		3FFh	

Legend:  = Unimplemented data memory locations, read as '0'.

Note 1: PIC12F1572 only.

TABLE 3-5: PIC12(L)F1571/2 MEMORY MAP, BANK 8-23

BANK 8		BANK 9		BANK 10		BANK 11		BANK 12		BANK 13		BANK 14		BANK 15	
400h	Core Registers (Table 3-2)	480h	Core Registers (Table 3-2)	500h	Core Registers (Table 3-2)	580h	Core Registers (Table 3-2)	600h	Core Registers (Table 3-2)	680h	Core Registers (Table 3-2)	700h	Core Registers (Table 3-2)	780h	Core Registers (Table 3-2)
40Bh	—	48Bh	—	50Bh	—	58Bh	—	60Bh	—	68Bh	—	70Bh	—	78Bh	—
40Ch	—	48Ch	—	50Ch	—	58Ch	—	60Ch	—	68Ch	—	70Ch	—	78Ch	—
40Dh	—	48Dh	—	50Dh	—	58Dh	—	60Dh	—	68Dh	—	70Dh	—	78Dh	—
40Eh	—	48Eh	—	50Eh	—	58Eh	—	60Eh	—	68Eh	—	70Eh	—	78Eh	—
40Fh	—	48Fh	—	50Fh	—	58Fh	—	60Fh	—	68Fh	—	70Fh	—	78Fh	—
410h	—	490h	—	510h	—	590h	—	610h	—	690h	—	710h	—	790h	—
411h	—	491h	—	511h	—	591h	—	611h	—	691h	CWG1DBR	711h	—	791h	—
412h	—	492h	—	512h	—	592h	—	612h	—	692h	CWG1DBF	712h	—	792h	—
413h	—	493h	—	513h	—	593h	—	613h	—	693h	CWG1CON0	713h	—	793h	—
414h	—	494h	—	514h	—	594h	—	614h	—	694h	CWG1CON1	714h	—	794h	—
415h	—	495h	—	515h	—	595h	—	615h	—	695h	CWG1CON2	715h	—	795h	—
416h	—	496h	—	516h	—	596h	—	616h	—	696h	—	716h	—	796h	—
417h	—	497h	—	517h	—	597h	—	617h	—	697h	—	717h	—	797h	—
418h	—	498h	—	518h	—	598h	—	618h	—	698h	—	718h	—	798h	—
419h	—	499h	—	519h	—	599h	—	619h	—	699h	—	719h	—	799h	—
41Ah	—	49Ah	—	51Ah	—	59Ah	—	61Ah	—	69Ah	—	71Ah	—	79Ah	—
41Bh	—	49Bh	—	51Bh	—	59Bh	—	61Bh	—	69Bh	—	71Bh	—	79Bh	—
41Ch	—	49Ch	—	51Ch	—	59Ch	—	61Ch	—	69Ch	—	71Ch	—	79Ch	—
41Dh	—	49Dh	—	51Dh	—	59Dh	—	61Dh	—	69Dh	—	71Dh	—	79Dh	—
41Eh	—	49Eh	—	51Eh	—	59Eh	—	61Eh	—	69Eh	—	71Eh	—	79Eh	—
41Fh	—	49Fh	—	51Fh	—	59Fh	—	61Fh	—	69Fh	—	71Fh	—	79Fh	—
420h	Unimplemented Read as '0'	4A0h	Unimplemented Read as '0'	520h	Unimplemented Read as '0'	5A0h	Unimplemented Read as '0'	620h	Unimplemented Read as '0'	6A0h	Unimplemented Read as '0'	720h	Unimplemented Read as '0'	7A0h	Unimplemented Read as '0'
46Fh	—	4EFh	—	56Fh	—	5EFh	—	66Fh	—	6EFh	—	76Fh	—	7EFh	—
470h	Accesses 70h-7Fh	4F0h	Accesses 70h-7Fh	570h	Accesses 70h-7Fh	5F0h	Accesses 70h-7Fh	670h	Accesses 70h-7Fh	6F0h	Accesses 70h-7Fh	770h	Accesses 70h-7Fh	7F0h	Accesses 70h-7Fh
47Fh	—	4FFh	—	57Fh	—	5FFh	—	67Fh	—	6FFh	—	77Fh	—	7FFh	—
BANK 16		BANK 17		BANK 18		BANK 19		BANK 20		BANK 21		BANK 22		BANK 23	
800h	Core Registers (Table 3-2)	880h	Core Registers (Table 3-2)	900h	Core Registers (Table 3-2)	980h	Core Registers (Table 3-2)	A00h	Core Registers (Table 3-2)	A80h	Core Registers (Table 3-2)	B00h	Core Registers (Table 3-2)	B80h	Core Registers (Table 3-2)
80Bh	—	88Bh	—	90Bh	—	98Bh	—	A0Bh	—	A8Bh	—	B0Bh	—	B8Bh	—
80Ch	Unimplemented Read as '0'	88Ch	Unimplemented Read as '0'	90Ch	Unimplemented Read as '0'	98Ch	Unimplemented Read as '0'	A0Ch	Unimplemented Read as '0'	A8Ch	Unimplemented Read as '0'	B0Ch	Unimplemented Read as '0'	B8Ch	Unimplemented Read as '0'
86Fh	—	8EFh	—	96Fh	—	9EFh	—	A6Fh	—	A6Fh	—	B6Fh	—	BEFh	—
870h	Accesses 70h-7Fh	8F0h	Accesses 70h-7Fh	970h	Accesses 70h-7Fh	9F0h	Accesses 70h-7Fh	A70h	Accesses 70h-7Fh	A70h	Accesses 70h-7Fh	B70h	Accesses 70h-7Fh	BF0h	Accesses 70h-7Fh
87Fh	—	8FFh	—	97Fh	—	9FFh	—	A7Fh	—	AFFh	—	B7Fh	—	BFFh	—

Legend: □ = Unimplemented data memory locations, read as '0'.

**TABLE 3-6: PIC12(L)F1571/2 MEMORY MAP, BANK 24-31**

BANK 24		BANK 25		BANK 26		BANK 27		BANK 28		BANK 29		BANK 30		BANK 31	
C00h	Core Registers (Table 3-2)	C80h	Core Registers (Table 3-2)	D00h	Core Registers (Table 3-2)	D80h	Core Registers (Table 3-2)	E00h	Core Registers (Table 3-2)	E80h	Core Registers (Table 3-2)	F00h	Core Registers (Table 3-2)	F80h	Core Registers (Table 3-2)
C0Bh	—	C8Bh	—	D0Bh	—	D8Bh	See Table 3-7 for Register Mapping Details	E0Bh	—	E8Bh	—	F0Bh	—	F8Bh	See Table 3-7 for Register Mapping Details
C0Ch	—	C8Ch	—	D0Ch	—	D8Ch		E0Ch	—	E8Ch	—	F0Ch	—	F8Ch	
C0Dh	—	C8Dh	—	D0Dh	—			E0Dh	—	E8Dh	—	F0Dh	—		
C0Eh	—	C8Eh	—	D0Eh	—			E0Eh	—	E8Eh	—	F0Eh	—		
C0Fh	—	C8Fh	—	D0Fh	—			E0Fh	—	E8Fh	—	F0Fh	—		
C10h	—	C90h	—	D10h	—			E10h	—	E90h	—	F10h	—		
C11h	—	C91h	—	D11h	—			E11h	—	E91h	—	F11h	—		
C12h	—	C92h	—	D12h	—			E12h	—	E92h	—	F12h	—		
C13h	—	C93h	—	D13h	—			E13h	—	E93h	—	F13h	—		
C14h	—	C94h	—	D14h	—			E14h	—	E94h	—	F14h	—		
C15h	—	C95h	—	D15h	—			E15h	—	E95h	—	F15h	—		
C16h	—	C96h	—	D16h	—			E16h	—	E96h	—	F16h	—		
C17h	—	C97h	—	D17h	—			E17h	—	E97h	—	F17h	—		
C18h	—	C98h	—	D18h	—			E18h	—	E98h	—	F18h	—		
C19h	—	C99h	—	D19h	—			E19h	—	E99h	—	F19h	—		
C1Ah	—	C9Ah	—	D1Ah	—			E1Ah	—	E9Ah	—	F1Ah	—		
C1Bh	—	C9Bh	—	D1Bh	—		E1Bh	—	E9Bh	—	F1Bh	—			
C1Ch	—	C9Ch	—	D1Ch	—		E1Ch	—	E9Ch	—	F1Ch	—			
C1Dh	—	C9Dh	—	D1Dh	—		E1Dh	—	E9Dh	—	F1Dh	—			
C1Eh	—	C9Eh	—	D1Eh	—		E1Eh	—	E9Eh	—	F1Eh	—			
C1Fh	—	C9Fh	—	D1Fh	—		E1Fh	—	E9Fh	—	F1Fh	—			
C20h	Unimplemented Read as '0'	CA0h	Unimplemented Read as '0'	D20h	Unimplemented Read as '0'		E20h	Unimplemented Read as '0'	EA0h	Unimplemented Read as '0'	F20h	Unimplemented Read as '0'			
C6Fh	Accesses 70h-7Fh	CEFh	Accesses 70h-7Fh	D6Fh	Accesses 70h-7Fh	DEFh	Accesses 70h-7Fh	E6Fh	Accesses 70h-7Fh	EEFh	Accesses 70h-7Fh	F6Fh	Accesses 70h-7Fh	FEFh	Accesses 70h-7Fh
C70h		CF0h		D70h		DF0h		E70h		EF0h		F70h		FF0h	
CFFh		CFFh		D7Fh		DFFh		E7Fh		EFFh		F7Fh		FFFh	

**Legend:** □ = Unimplemented data memory locations, read as '0'.



**TABLE 3-7: PIC12(L)F1571/2 MEMORY MAP, BANK 27**

Bank 31	
D8Ch	—
D8Dh	—
D8Eh	PWMEN
D8Fh	PWMLD
D90h	PWMOUT
D91h	PWM1PHL
D92h	PWM1PHH
D93h	PWM1DCL
D94h	PWM1DCH
D95h	PWM1PRL
D96h	PWM1PRH
D97h	PWM1OFL
D98h	PWM1OFH
D99h	PWM1TMRL
D9Ah	PWM1TMRH
D9Bh	PWM1CON
D9Ch	PWM1INTE
D9Dh	PWM1INTF
D9Eh	PWM1CLKCON
D9Fh	PWM1LDCON
DA0h	PWM1OFCON
DA1h	PWM2PHL
DA2h	PWM2PHH
DA3h	PWM2DCL
DA4h	PWM2DCH
DA5h	PWM2PRL
DA6h	PWM2PRH
DA7h	PWM2OFL
DA8h	PWM2OFH
DA9h	PWM2TMRL
DAAh	PWM2TMRH
DABh	PWM2CON
DACh	PWM2INTE
DADh	PWM2INTF
DAEh	PWM2CLKCON
DAFh	PWM2LDCON
DB0h	PWM2OFCON
DB1h	PWM3PHL
DB2h	PWM3PHH
DB3h	PWM3DCL
DB4h	PWM3DCH
DB5h	PWM2PRL
DB6h	PWM3PRH
DB7h	PWM3OFL
DB8h	PWM3OFH
DB9h	PWM3TMRL
DBAh	PWM3TMRH
DBBh	PWM3CON
DBCh	PWM3INTE
DBDh	PWM3INTF
DBEh	PWM3CLKCON
DBFh	PWM3LDCON
DC0h	PWM3OFCON
DC1h	—
DEFh	—

**Legend:**  = Unimplemented data memory locations, read as '0'.

**TABLE 3-8: PIC12(L)F1571/2 MEMORY MAP, BANK 31**

Bank 31		
F8Ch	Unimplemented Read as '0'	
FE3h		
FE4h		STATUS_SHAD
FE5h		WREG_SHAD
FE6h		BSR_SHAD
FE7h		PCLATH_SHAD
FE8h		FSR0L_SHAD
FE9h		FSR0H_SHAD
FEAh		FSR1L_SHAD
FEBh		FSR1H_SHAD
FEC	—	
FEDh	STKPTR	
FEEh	TOSL	
FEFh	TOSH	

**Legend:**  = Unimplemented data memory locations, read as '0'.

# PIC12(L)F1571/2

## 3.3.6 CORE FUNCTION REGISTERS SUMMARY

The Core Function registers listed in [Table 3-9](#) can be addressed from any bank.

**TABLE 3-9: CORE FUNCTION REGISTERS SUMMARY**

Addr	Name	Bit 7	Bit 6	Bit 5	Bit 4	Bit 3	Bit 2	Bit 1	Bit 0	Value on POR, BOR	Value on All Other Resets	
<b>Bank 0-31</b>												
x00h or x80h	INDF0	Addressing this location uses contents of FSR0H/FSR0L to address data memory (not a physical register)								xxxx xxxx	uuuu uuuu	
x01h or x81h	INDF1	Addressing this location uses contents of FSR1H/FSR1L to address data memory (not a physical register)								xxxx xxxx	uuuu uuuu	
x02h or x82h	PCL	Program Counter (PC) Least Significant Byte								0000 0000	0000 0000	
x03h or x83h	STATUS	—	—	—	$\overline{TO}$	$\overline{PD}$	Z	DC	C	---1 1000	---q quuu	
x04h or x84h	FSR0L	Indirect Data Memory Address 0 Low Pointer								0000 0000	uuuu uuuu	
x05h or x85h	FSR0H	Indirect Data Memory Address 0 High Pointer								0000 0000	0000 0000	
x06h or x86h	FSR1L	Indirect Data Memory Address 1 Low Pointer								0000 0000	uuuu uuuu	
x07h or x87h	FSR1H	Indirect Data Memory Address 1 High Pointer								0000 0000	0000 0000	
x08h or x88h	BSR	—	—	—	BSR<4:0>				---	0 0000	---	0 0000
x09h or x89h	WREG	Working Register								0000 0000	uuuu uuuu	
x0Ah or x8Ah	PCLATH	—	Write Buffer for the Upper 7 bits of the Program Counter								-000 0000	-000 0000
x0Bh or x8Bh	INTCON	GIE	PEIE	TMR0IE	INTE	IOCF	TMR0IF	INTF	IOCF	0000 0000	0000 0000	

**Legend:** x = unknown; u = unchanged; q = value depends on condition; — = unimplemented, read as '0'; r = reserved.  
Shaded locations are unimplemented, read as '0'.

**TABLE 3-10: SPECIAL FUNCTION REGISTER SUMMARY**

Addr	Name	Bit 7	Bit 6	Bit 5	Bit 4	Bit 3	Bit 2	Bit 1	Bit 0	Value on POR, BOR	Value on All Other Resets		
<b>Bank 0</b>													
00Ch	PORTA	—	—	RA<5:0>						--xx xxxx	--xx xxxx		
00Dh	—	Unimplemented										—	—
00Eh	—	Unimplemented										—	—
00Fh	—	Unimplemented										—	—
010h	—	Unimplemented										—	—
011h	PIR1	TMR1GIF	ADIF	RCIF <sup>(2)</sup>	TXIF <sup>(2)</sup>	—	—	TMR2IF	TMR1IF	0000 --00	0000 --00		
012h	PIR2	—	—	C1IF	—	—	—	—	—	--0- ----	--0- ----		
013h	PIR3	—	PWM3IF	PWM2IF	PWM1IF	—	—	—	—	-000 ----	-000 ----		
014h	—	Unimplemented										—	—
015h	TMR0	Holding Register for the 8-Bit Timer0 Count								xxxx xxxx	uuuu uuuu		
016h	TMR1L	Holding Register for the Least Significant Byte of the 16-Bit TMR1 Count								xxxx xxxx	uuuu uuuu		
017h	TMR1H	Holding Register for the Most Significant Byte of the 16-Bit TMR1 Count								xxxx xxxx	uuuu uuuu		
018h	T1CON	TMR1CS<1:0>		T1CKPS<1:0>		—	T1SYNC	—	TMR1ON	0000 -0-0	uuuu -u-u		
019h	T1GCON	TMR1GE	T1GPOL	T1GTM	T1GSPM	T1GGO/DONE	T1GVAL	T1GSS<1:0>		0000 0x00	uuuu uxuu		
01Ah	TMR2	Timer2 Module Register										0000 0000	0000 0000
01Bh	PR2	Timer2 Period Register										1111 1111	1111 1111
01Ch	T2CON	—	T2OUTPS<3:0>				—	TMR2ON	T2CKPS<1:0>		-000 0000	-000 0000	
01Dh	—	Unimplemented										—	—
01Eh	—	Unimplemented										—	—
01Fh	—	Unimplemented										—	—
<b>Bank 1</b>													
08Ch	TRISA	—	—	TRISA<5:4>		— <sup>(2)</sup>	TRISA<2:0>			--11 1111	--11 1111		
08Dh	—	Unimplemented										—	—
08Eh	—	Unimplemented										—	—
08Fh	—	Unimplemented										—	—
090h	—	Unimplemented										—	—
091h	PIE1	TMR1GIE	ADIE	RCIE <sup>(2)</sup>	TXIE <sup>(2)</sup>	—	—	TMR2IE	TMR1IE	0000 --00	0000 --00		
092h	PIE2	—	—	C1IE	—	—	—	—	—	--0- ----	--0- ----		
093h	PIE3	—	PWM3IE	PWM2IE	PWM1IE	—	—	—	—	-000 ----	-000 ----		
094h	—	Unimplemented										—	—
095h	OPTION_REG	WPUEN	INTEDG	TMR0CS	TMR0SE	PSA	PS<2:0>			1111 1111	1111 1111		
096h	PCON	STKOVF	STKUNF	—	RWD $\overline{T}$	RMCLR	RI	POR	BOR	00-1 11qq	qq-q qquu		
097h	WDTCON	—	—	WDTPS<4:0>					SWDTEN	--01 0110	--01 0110		
098h	OSCTUNE	—	—	TUN<5:0>						--00 0000	--00 0000		
099h	OSCCON	SPLLEN	IRCF<3:0>				—	SCS<1:0>			0011 1-00	0011 1-00	
09Ah	OSCSTAT	—	PLL	OSTS	HFIOFR	HFIOFL	MFIOFR	LFIOFR	HFIOFS	-0q0 0q00	-qqq qqqq		
09Bh	ADRESL	ADC Result Register Low								xxxx xxxx	uuuu uuuu		
09Ch	ADRESH	ADC Result Register High								xxxx xxxx	uuuu uuuu		
09Dh	ADCON0	—	CHS<4:0>					GO/DONE	ADON	-000 0000	-000 0000		
09Eh	ADCON1	ADFM	ADCS<2:0>			—	—	ADPREF<1:0>		0000 --00	0000 --00		
09Fh	ADCON2	TRIGSEL<3:0>						—	—	0000 ----	0000 ----		

**Legend:** x = unknown; u = unchanged; q = value depends on condition; — = unimplemented; r = reserved. Shaded locations are unimplemented, read as '0'.

**Note 1:** PIC12F1571/2 only.

**2:** PIC12(L)F1572 only.

**3:** Unimplemented, read as '1'.

# PIC12(L)F1571/2

**TABLE 3-10: SPECIAL FUNCTION REGISTER SUMMARY (CONTINUED)**

Addr	Name	Bit 7	Bit 6	Bit 5	Bit 4	Bit 3	Bit 2	Bit 1	Bit 0	Value on POR, BOR	Value on All Other Resets		
<b>Bank 2</b>													
10Ch	LATA	—	—	LATA<5:4>		—	LATA<2:0>			--xx -xxx	--uu -uuu		
10Dh	—	Unimplemented									—	—	
10Eh	—	Unimplemented									—	—	
10Fh	—	Unimplemented									—	—	
110h	—	Unimplemented									—	—	
111h	CM1CON0	C1ON	C1OUT	C1OE	C1POL	—	C1SP	C1HYS	C1SYNC	0000 -100	0000 -100		
112h	CM1CON1	C1INTP	C1INTN	C1PCH<1:0>		—	C1NCH<2:0>			0000 -000	0000 -000		
113h	—	Unimplemented									—	—	
114h	—	Unimplemented									—	—	
115h	CMOUT	—	—	—	—	—	—	—	MC1OUT	---- --0	---- --0		
116h	BORCON	SBOREN	BORFS	—	—	—	—	—	BORRDY	10-- --q	uu-- --u		
117h	FVRCON	FVREN	FVRRDY	TSEN	TSRNG	CDAFVR<1:0>		ADFVR<1:0>		0q00 0000	0q00 0000		
118h	DAC1CON0	DACEN	—	DACOE	—	DACPSS<1:0>		—	—	0-0- 00--	0-0- 00--		
119h	DAC1CON1	—	—	—	DACR<4:0>				—	—	---0 0000	---0 0000	
11Ah to 11Ch	—	Unimplemented									—	—	
11Dh	APFCON	RXDTSEL	CWGASEL	CWGBSEL	—	T1GSEL	TXCKSEL	P2SEL	P1SEL	000- 0000	000- 0000		
11Eh	—	Unimplemented									—	—	
11Fh	—	Unimplemented									—	—	
<b>Bank 3</b>													
18Ch	ANSELA	—	—	—	ANSA4	—	ANSA<2:0>			---1 -111	---1 -111		
18Dh	—	Unimplemented									—	—	
18Eh	—	Unimplemented									—	—	
18Fh	—	Unimplemented									—	—	
190h	—	Unimplemented									—	—	
191h	PMADRL	Flash Program Memory Address Register Low Byte									0000 0000	0000 0000	
192h	PMADRH	— <sup>(3)</sup>	Flash Program Memory Address Register High Byte									1000 0000	1000 0000
193h	PMDATL	Flash Program Memory Read Data Register Low Byte									xxxx xxxx	uuuu uuuu	
194h	PMDATH	—	—	Flash Program Memory Read Data Register High Byte						—xx xxxx	--uu uuuu		
195h	PMCON1	— <sup>(3)</sup>	CFGS	LWLO	FREE	WRERR	WREN	WR	RD	1000 x000	1000 q000		
196h	PMCON2	Flash Program Memory Control Register 2									0000 0000	0000 0000	
197h	VREGCON <sup>(1)</sup>	—	—	—	—	—	—	VREGPM	Reserved	---- --01	---- --01		
198h	—	Unimplemented									—	—	
199h	RCREG	USART Receive Data Register									0000 0000	0000 0000	
19Ah	TXREG	USART Transmit Data Register									0000 0000	0000 0000	
19Bh	SPBRGL	Baud Rate Generator Data Register Low									0000 0000	0000 0000	
19Ch	SPBRGH	Baud Rate Generator Data Register High									0000 0000	0000 0000	
19Dh	RCSTA	SPEN	RX9	SREN	CREN	ADDEN	FERR	OERR	RX9D	0000 000x	0000 000x		
19Eh	TXSTA	CSRC	TX9	TXEN	SYNC	SENDB	BRGH	TRMT	TX9D	0000 0010	0000 0010		
19Fh	BAUDCON	ABDOVF	RCIDL	—	SCKP	BRG16	—	WUE	ABDEN	01-0 0-00	01-0 0-00		

**Legend:** x = unknown; u = unchanged; q = value depends on condition; — = unimplemented; r = reserved. Shaded locations are unimplemented, read as '0'.

**Note 1:** PIC12F1571/2 only.

**2:** PIC12(L)F1572 only.

**3:** Unimplemented, read as '1'.

**TABLE 3-10: SPECIAL FUNCTION REGISTER SUMMARY (CONTINUED)**

Addr	Name	Bit 7	Bit 6	Bit 5	Bit 4	Bit 3	Bit 2	Bit 1	Bit 0	Value on POR, BOR	Value on All Other Resets	
<b>Bank 4</b>												
20Ch	WPUA	—	—	WPUA<5:0>						--11 1111	--11 1111	
20Dh	—	Unimplemented									—	—
20Eh to 21Fh	—	Unimplemented									—	—
<b>Bank 5</b>												
28Ch	ODCONA	—	—	ODA<5:4>		—	ODA<2:0>			--11 -111	--11 -111	
28Dh to 29Fh	—	Unimplemented									—	—
<b>Bank 6</b>												
30Ch	SLRCONA	—	—	SLRA<5:4>		—	SLRA<2:0>			--11 -111	--11 -111	
30Dh to 31Fh	—	Unimplemented									—	—
<b>Bank 7</b>												
38Ch	INLVLA	—	—	INLVLA<5:0>						--11 1111	--11 1111	
38Dh to 390h	—	Unimplemented									—	—
391h	IOCAP	—	—	IOCAP<5:0>						--00 0000	--00 0000	
392h	IOCAN	—	—	IOCAN<5:0>						--00 0000	--00 0000	
393h	IOCAF	—	—	IOCAF<5:0>						--00 0000	--00 0000	
394h to 39Fh	—	Unimplemented									—	—
<b>Bank 8</b>												
40Ch to 41Fh	—	Unimplemented									—	—
<b>Bank 9</b>												
48Ch to 49Fh	—	Unimplemented									—	—

**Legend:** x = unknown; u = unchanged; q = value depends on condition; — = unimplemented; r = reserved. Shaded locations are unimplemented, read as '0'.

**Note 1:** PIC12F1571/2 only.

**2:** PIC12(L)F1572 only.

**3:** Unimplemented, read as '1'.

# PIC12(L)F1571/2

**TABLE 3-10: SPECIAL FUNCTION REGISTER SUMMARY (CONTINUED)**

Addr	Name	Bit 7	Bit 6	Bit 5	Bit 4	Bit 3	Bit 2	Bit 1	Bit 0	Value on POR, BOR	Value on All Other Resets
<b>Bank 10</b>											
50Ch to 51Fh	—	Unimplemented								—	—
<b>Bank 11</b>											
58Ch to 59Fh	—	Unimplemented								—	—
<b>Bank 12</b>											
60Ch to 61Fh	—	Unimplemented								—	—
<b>Bank 13</b>											
68Ch to 690h	—	Unimplemented								—	—
691h	CWG1DBR	—	—	CWG1DBR<5:0>						--00 0000	--00 0000
692h	CWG1DBF	—	—	CWG1DBF<5:0>						--xx xxxxx	--xx xxxxx
693h	CWG1CON0	G1EN	G1OEB	G1OEA	G1POLB	G1POLA	—	—	G1CS0	0000 0--0	0000 0--0
694h	CWG1CON1	G1ASDLB<1:0>		G1ASDLA<1:0>		—	G1IS<2:0>			0000 -000	0000 -000
695h	CWG1CON2	G1ASE	G1ARSEN	—	—	—	G1ASDSC1	G1ASDSFLT	—	00-- -00-	00-- -00-
696h to 69Fh	—	Unimplemented								—	—
<b>Banks 14-26</b>											
x0Ch/ x8Ch — x1Fh/ x9Fh	—	Unimplemented								—	—

**Legend:** x = unknown; u = unchanged; q = value depends on condition; — = unimplemented; r = reserved. Shaded locations are unimplemented, read as '0'.

- Note 1:** PIC12F1571/2 only.  
**2:** PIC12(L)F1572 only.  
**3:** Unimplemented, read as '1'.

**TABLE 3-10: SPECIAL FUNCTION REGISTER SUMMARY (CONTINUED)**

Addr	Name	Bit 7	Bit 6	Bit 5	Bit 4	Bit 3	Bit 2	Bit 1	Bit 0	Value on POR, BOR	Value on All Other Resets	
<b>Bank 27</b>												
D8Ch	—	Unimplemented									—	—
D8Dh	—	Unimplemented									—	—
D8Eh	PWMEN	—	—	—	—	—	PWM3EN_A	PWM2EN_A	PWM1EN_A	---- -000	---- -000	
D8Fh	PWMLD	—	—	—	—	—	PWM3LDA_A	PWM2LDA_A	PWM1LDA_A	---- -000	---- -000	
D90h	PWMOUT	—	—	—	—	—	PWM3OUT_A	PWM2OUT_A	PWM1OUT_A	---- -000	---- -000	
D91h	PWM1PHL	PH<7:0>						xxxx	xxxx	uuuu	uuuu	
D92h	PWM1PHH	PH<15:8>						xxxx	xxxx	uuuu	uuuu	
D93h	PWM1DCL	DC<7:0>						xxxx	xxxx	uuuu	uuuu	
D94h	PWM1DCH	DC<15:8>						xxxx	xxxx	uuuu	uuuu	
D95h	PWM1PRL	PR<7:0>						xxxx	xxxx	uuuu	uuuu	
D96h	PWM1PRH	PR<15:8>						xxxx	xxxx	uuuu	uuuu	
D97h	PWM1OFL	OF<7:0>						xxxx	xxxx	uuuu	uuuu	
D98h	PWM1OFH	OF<15:8>						xxxx	xxxx	uuuu	uuuu	
D99h	PWM1TMRH	TMR<7:0>						xxxx	xxxx	uuuu	uuuu	
D9Ah	PWM1TMRH	TMR<15:8>						xxxx	xxxx	uuuu	uuuu	
D9Bh	PWM1CON	PWM1EN	PWM1OE	PWM1OUT	PWM1POL	PWM1MODE<1:0>		—	—	0000 00--	0000 00--	
D9Ch	PWM1INTE	—	—	—	—	PWM1OFIE	PWM1PHIE	PWM1DCIE	PWM1PRIE	---- 000	---- 000	
D9Dh	PWM1INTF	—	—	—	—	PWM1OFIF	PWM1PHIF	PWM1DCIF	PWM1PRIF	---- 000	---- 000	
D9Eh	PWM1CLKCON	—	PWM1PS<2:0>			—	—	PWM1CS<1:0>		-000 -000	-000 --00	
D9Fh	PWM1LDCON	PWM1LDA	PWM1LDT	—	—	—	—	PWM1LDS<1:0>		00-- -000	00-- --00	
DA0h	PWM1OFCON	—	PWM1OFM<1:0>		PWM1OFO	—	—	PWM1OFS<1:0>		-000 -000	-000 --00	
DA1h	PWM2PHL	PH<7:0>						xxxx	xxxx	uuuu	uuuu	
DA2h	PWM2PHH	PH<15:8>						xxxx	xxxx	uuuu	uuuu	
DA3h	PWM2DCL	DC<7:0>						xxxx	xxxx	uuuu	uuuu	
DA4h	PWM2DCH	DC<15:8>						xxxx	xxxx	uuuu	uuuu	
DA5h	PWM2PRL	PR<7:0>						xxxx	xxxx	uuuu	uuuu	
DA6h	PWM2PRH	PR<15:8>						xxxx	xxxx	uuuu	uuuu	
DA7h	PWM2OFL	OF<7:0>						xxxx	xxxx	uuuu	uuuu	
DA8h	PWM2OFH	OF<15:8>						xxxx	xxxx	uuuu	uuuu	
DA9h	PWM2TMRH	TMR<7:0>						xxxx	xxxx	uuuu	uuuu	
DAAh	PWM2TMRH	TMR<15:8>						xxxx	xxxx	uuuu	uuuu	
DABh	PWM2CON	PWM2EN	PWM2OE	PWM2OUT	PWM2POL	PWM2MODE<1:0>		—	—	0000 00--	0000 00--	
DACH	PWM2INTE	—	—	—	—	PWM2OFIE	PWM2PHIE	PWM2DCIE	PWM2PRIE	---- 000	---- 000	
DADh	PWM2INTF	—	—	—	—	PWM2OFIF	PWM2PHIF	PWM2DCIF	PWM2PRIF	---- 000	---- 000	
DAEh	PWM2CLKCON	—	PWM2PS<2:0>			—	—	PWM2CS<1:0>		-000 -000	-000 --00	
DAFh	PWM2LDCON	PWM2LDA	PWM2LDT	—	—	—	—	PWM2LDS<1:0>		00-- -000	00-- --00	

**Legend:** x = unknown; u = unchanged; q = value depends on condition; — = unimplemented; r = reserved. Shaded locations are unimplemented, read as '0'.

**Note 1:** PIC12F1571/2 only.

**2:** PIC12(L)F1572 only.

**3:** Unimplemented, read as '1'.

# PIC12(L)F1571/2

**TABLE 3-10: SPECIAL FUNCTION REGISTER SUMMARY (CONTINUED)**

Addr	Name	Bit 7	Bit 6	Bit 5	Bit 4	Bit 3	Bit 2	Bit 1	Bit 0	Value on POR, BOR	Value on All Other Resets
<b>Bank 27 (Continued)</b>											
DB0h	PWM2OFCON	—	PWM2OFM<1:0>		PWM2OFO	—	—	PWM2OFS<1:0>		-000 -000	-000 --00
DB1h	PWM3PHL	PH<7:0>						xxxx	xxxx	uuuu	uuuu
DB2h	PWM3PHH	PH<15:8>						xxxx	xxxx	uuuu	uuuu
DB3h	PWM3DCL	DC<7:0>						xxxx	xxxx	uuuu	uuuu
DB4h	PWM3DCH	DC<15:8>						xxxx	xxxx	uuuu	uuuu
DB5h	PWM3PRL	PR<7:0>						xxxx	xxxx	uuuu	uuuu
DB6h	PWM3PRH	PR<15:8>						xxxx	xxxx	uuuu	uuuu
DB7h	PWM3OFL	OF<7:0>						xxxx	xxxx	uuuu	uuuu
DA8h	PWM3OFH	OF<15:8>						xxxx	xxxx	uuuu	uuuu
DA9h	PWM3TMRL	TMR<7:0>						xxxx	xxxx	uuuu	uuuu
DBAh	PWM3TMRH	TMR<15:8>						xxxx	xxxx	uuuu	uuuu
DBBh	PWM3CON	PWM3EN	PWM3OE	PWM3OUT	PWM3POL	PWM3MODE<1:0>		—	—	0000 00--	0000 00--
DBCh	PWM3INTE	—	—	—	—	PWM3OFIE	PWM3PHIE	PWM3DCIE	PWM3PRIE	---- 000	---- 000
DBDh	PWM3INTF	—	—	—	—	PWM3OFIF	PWM3PHIF	PWM3DCIF	PWM3PRIF	---- 000	---- 000
DBEh	PWM3CLKCON	—	PWM3PS<2:0>			—	—	PWM3CS<1:0>		-000 -000	-000 --00
DBFh	PWM3LDCON	PWM3LDA	PWM3LDT	—	—	—	—	PWM3LDS<1:0>		00-- -000	00-- --00
DC0h	PWM3OFCON	—	PWM3OFM<1:0>		PWM3OFO	—	—	PWM3OFS<1:0>		-000 -000	-000 --00
<b>Bank 28-30</b>											
58Ch to 59Fh	—	Unimplemented								—	—

**Legend:** x = unknown; u = unchanged; c = value depends on condition; — = unimplemented; r = reserved. Shaded locations are unimplemented, read as '0'.

**Note 1:** PIC12F1571/2 only.

**Note 2:** PIC12(L)F1572 only.

**Note 3:** Unimplemented, read as '1'.



**TABLE 3-10: SPECIAL FUNCTION REGISTER SUMMARY (CONTINUED)**

Addr	Name	Bit 7	Bit 6	Bit 5	Bit 4	Bit 3	Bit 2	Bit 1	Bit 0	Value on POR, BOR	Value on All Other Resets	
<b>Bank 31</b>												
F8Ch — FE3h	—	Unimplemented								—	—	
FE4h	STATUS_SHAD	—	—	—	—	—	Z_SHAD	DC_SHAD	C_SHAD	---- -xxx	---- -uuu	
FE5h	WREG_SHAD	Working Register Shadow								xxxx xxxx	uuuu uuuu	
FE6h	BSR_SHAD	—	—	—	Bank Select Register Shadow					---x xxxx	---u uuuu	
FE7h	PCLATH_SHAD	—	Program Counter Latch High Register Shadow								-xxx xxxx	uuuu uuuu
FE8h	FSR0L_SHAD	Indirect Data Memory Address 0 Low Pointer Shadow								xxxx xxxx	uuuu uuuu	
FE9h	FSR0H_SHAD	Indirect Data Memory Address 0 High Pointer Shadow								xxxx xxxx	uuuu uuuu	
FEAh	FSR1L_SHAD	Indirect Data Memory Address 1 Low Pointer Shadow								xxxx xxxx	uuuu uuuu	
FEBh	FSR1H_SHAD	Indirect Data Memory Address 1 High Pointer Shadow								xxxx xxxx	uuuu uuuu	
FECh	—	Unimplemented								—	—	
FEDh	STKPTR	—	—	—	Current Stack Pointer					---1 1111	---1 1111	
FEEh	TOSL	Top-of-Stack Low Byte								xxxx xxxx	uuuu uuuu	
FEFh	TOSH	—	Top-of-Stack High Byte								-xxx xxxx	-uuu uuuu

**Legend:** x = unknown; u = unchanged; q = value depends on condition; — = unimplemented; r = reserved. Shaded locations are unimplemented, read as '0'.

**Note 1:** PIC12F1571/2 only.

**2:** PIC12(L)F1572 only.

**3:** Unimplemented, read as '1'.

# PIC12(L)F1571/2

## 3.4 PCL and PCLATH

The Program Counter (PC) is 15 bits wide. The low byte comes from the PCL register, which is a readable and writable register. The high byte (PC<14:8>) is not directly readable or writable and comes from PCLATH. On any Reset, the PC is cleared. Figure 3-4 shows the five situations for the loading of the PC.

**FIGURE 3-4: LOADING OF PC IN DIFFERENT SITUATIONS**

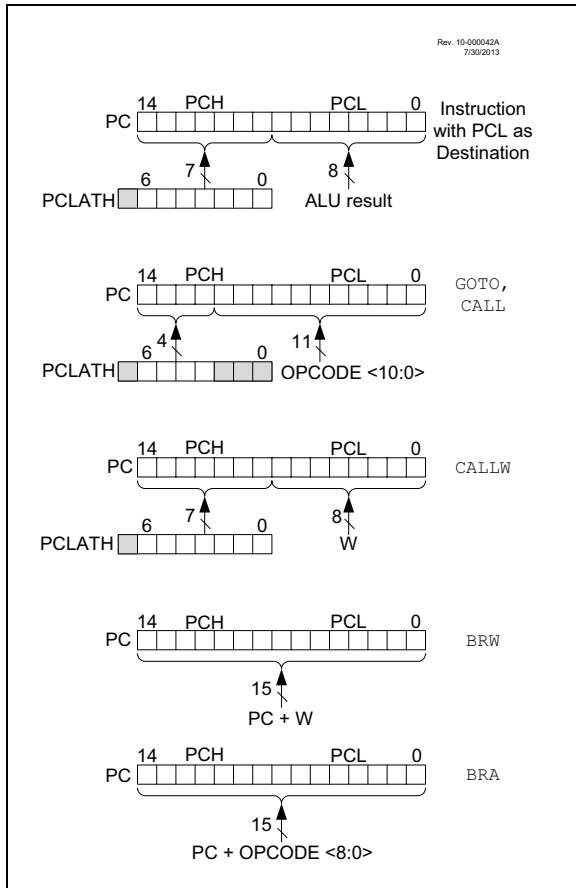

### 3.4.1 MODIFYING PCL

Executing any instruction with the PCL register as the destination simultaneously causes the Program Counter PC<14:8> bits (PCH) to be replaced by the contents of the PCLATH register. This allows the entire contents of the Program Counter to be changed by writing the desired upper seven bits to the PCLATH register. When the lower eight bits are written to the PCL register, all 15 bits of the Program Counter will change to the values contained in the PCLATH register and those being written to the PCL register.

### 3.4.2 COMPUTED GOTO

A computed GOTO is accomplished by adding an offset to the Program Counter (ADDWF PCL). When performing a table read using a computed GOTO method, care should be exercised if the table location crosses a PCL memory boundary (each 256-byte block). Refer to Application Note AN556, "Implementing a Table Read" (DS00556).

### 3.4.3 COMPUTED FUNCTION CALLS

A computed function CALL allows programs to maintain tables of functions and provides another way to execute state machines or look-up tables. When performing a table read using a computed function CALL, care should be exercised if the table location crosses a PCL memory boundary (each 256-byte block).

If using the CALL instruction, the PCH<2:0> and PCL registers are loaded with the operand of the CALL instruction. PCH<6:3> is loaded with PCLATH<6:3>.

The CALLW instruction enables computed CALLS by combining PCLATH and W to form the destination address. A computed CALLW is accomplished by loading the W register with the desired address and executing CALLW. The PCL register is loaded with the value of W and PCH is loaded with PCLATH.

### 3.4.4 BRANCHING

The branching instructions add an offset to the PC. This allows relocatable code and code that crosses page boundaries. There are two forms of branching, BRW and BRA. The PC will have incremented to fetch the next instruction in both cases. When using either branching instruction, a PCL memory boundary may be crossed.

If using BRW, load the W register with the desired unsigned address and execute BRW. The entire PC will be loaded with the address, PC + 1 + W.

If using BRA, the entire PC will be loaded with PC + 1 +, the signed value of the operand of the BRA instruction.

## 3.5 Stack

All devices have a 16-level x 15-bit wide hardware stack (refer to Figures 3-5 through 3-8). The stack space is not part of either program or data space. The PC is PUSHed onto the stack when `CALL` or `CALLW` instructions are executed, or an interrupt causes a branch. The stack is POPed in the event of a `RETURN`, `RETLW` or `RETFIE` instruction execution. `PCLATH` is not affected by a `PUSH` or `POP` operation.

The stack operates as a circular buffer if the `STVREN` bit is programmed to '0' (Configuration Words). This means that after the stack has been PUSHed sixteen times, the seventeenth PUSH overwrites the value that was stored from the first PUSH. The eighteenth PUSH overwrites the second PUSH (and so on). The `STKOVF` and `STKUNF` flag bits will be set on an overflow/underflow, regardless of whether the Reset is enabled.

**Note 1:** There are no instructions/mnemonics called `PUSH` or `POP`. These are actions that occur from the execution of the `CALL`, `CALLW`, `RETURN`, `RETLW` and `RETFIE` instructions or the vectoring to an interrupt address.

### 3.5.1 ACCESSING THE STACK

The stack is available through the `TOSH`, `TOSL` and `STKPTR` registers. `STKPTR` is the current value of the Stack Pointer. The `TOSH:TOSL` register pair points to the top of the stack. Both registers are read/writable. `TOS` is split into `TOSH` and `TOSL` due to the 15-bit size of the PC. To access the stack, adjust the value of `STKPTR`, which will position `TOSH:TOSL`, then read/write to `TOSH:TOSL`. The `STKPTR` is 5 bits to allow detection of overflow and underflow.

**Note:** Care should be taken when modifying the `STKPTR` while interrupts are enabled.

During normal program operation, `CALL`, `CALLW` and interrupts will increment `STKPTR` while `RETLW`, `RETURN` and `RETFIE` will decrement `STKPTR`. At any time, the `STKPTR` can be inspected to see how much stack is left. The `STKPTR` always points at the currently used place on the stack. Therefore, a `CALL` or `CALLW` will increment the `STKPTR` and then write the PC, and a return will unload the PC and then decrement the `STKPTR`.

Reference Figure 3-5 through Figure 3-8 for examples of accessing the stack.

**FIGURE 3-5: ACCESSING THE STACK EXAMPLE 1**

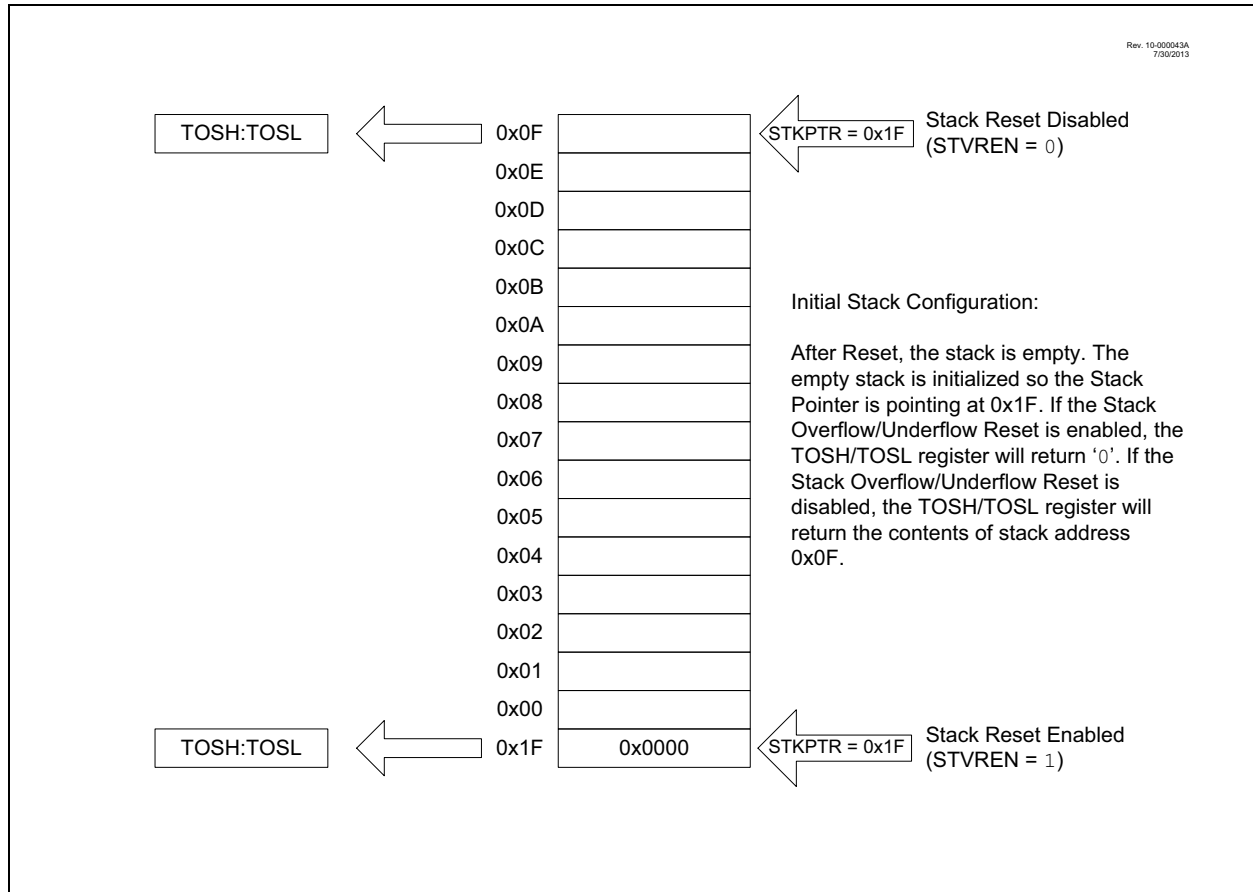

# PIC12(L)F1571/2

**FIGURE 3-6: ACCESSING THE STACK EXAMPLE 2**

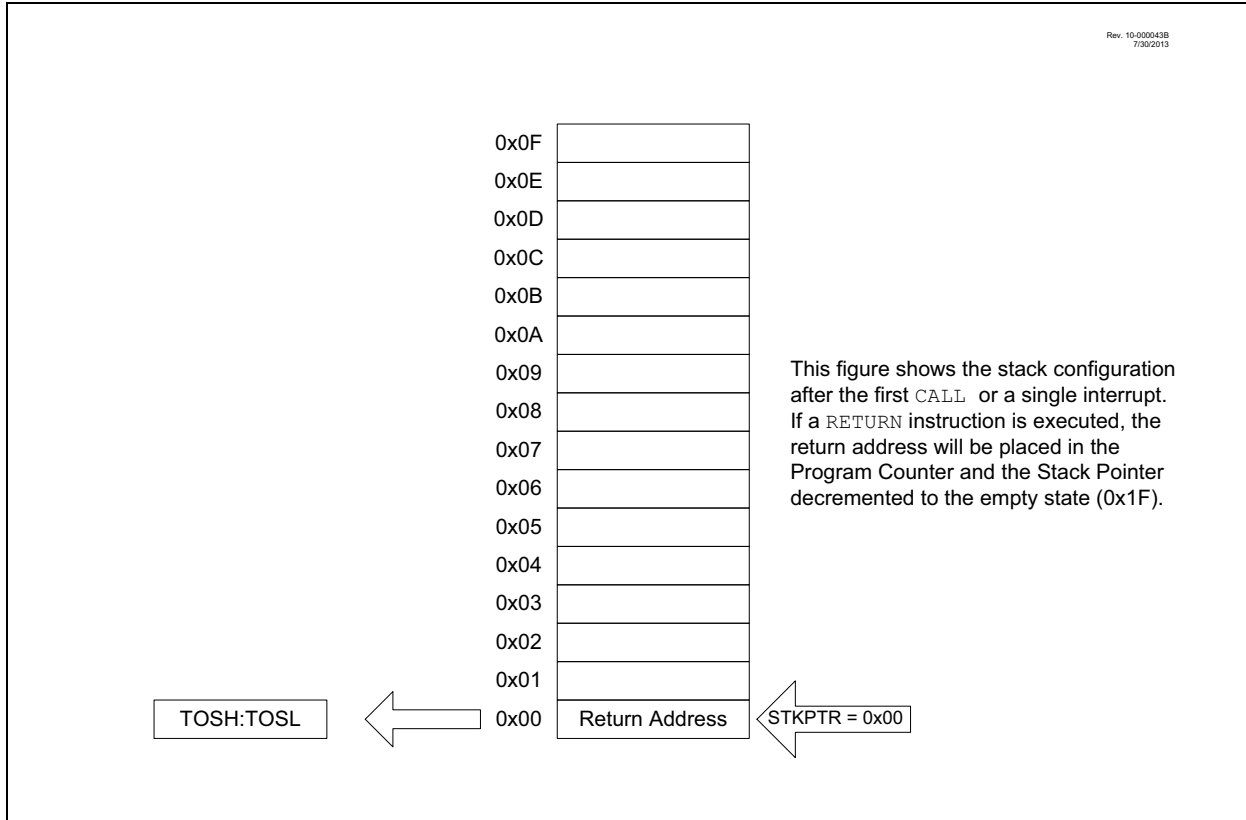

**FIGURE 3-7: ACCESSING THE STACK EXAMPLE 3**

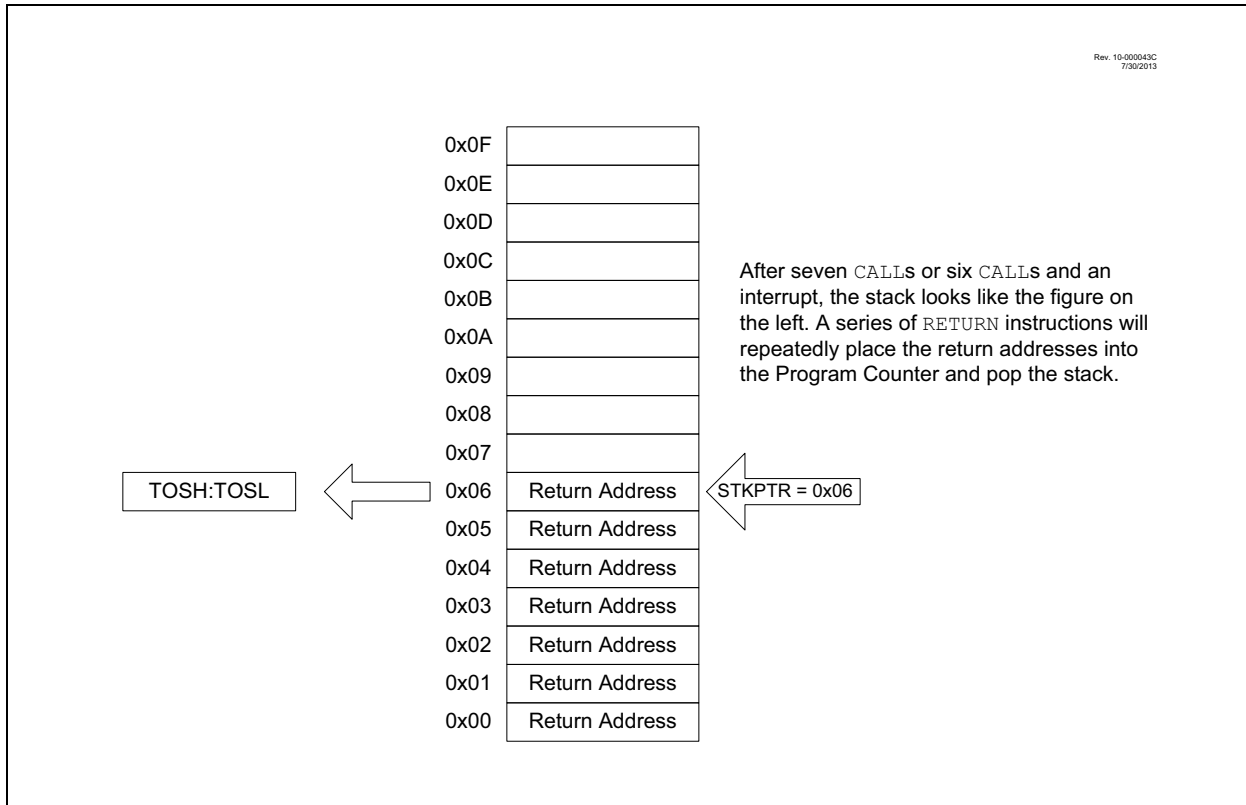

**FIGURE 3-8: ACCESSING THE STACK EXAMPLE 4**

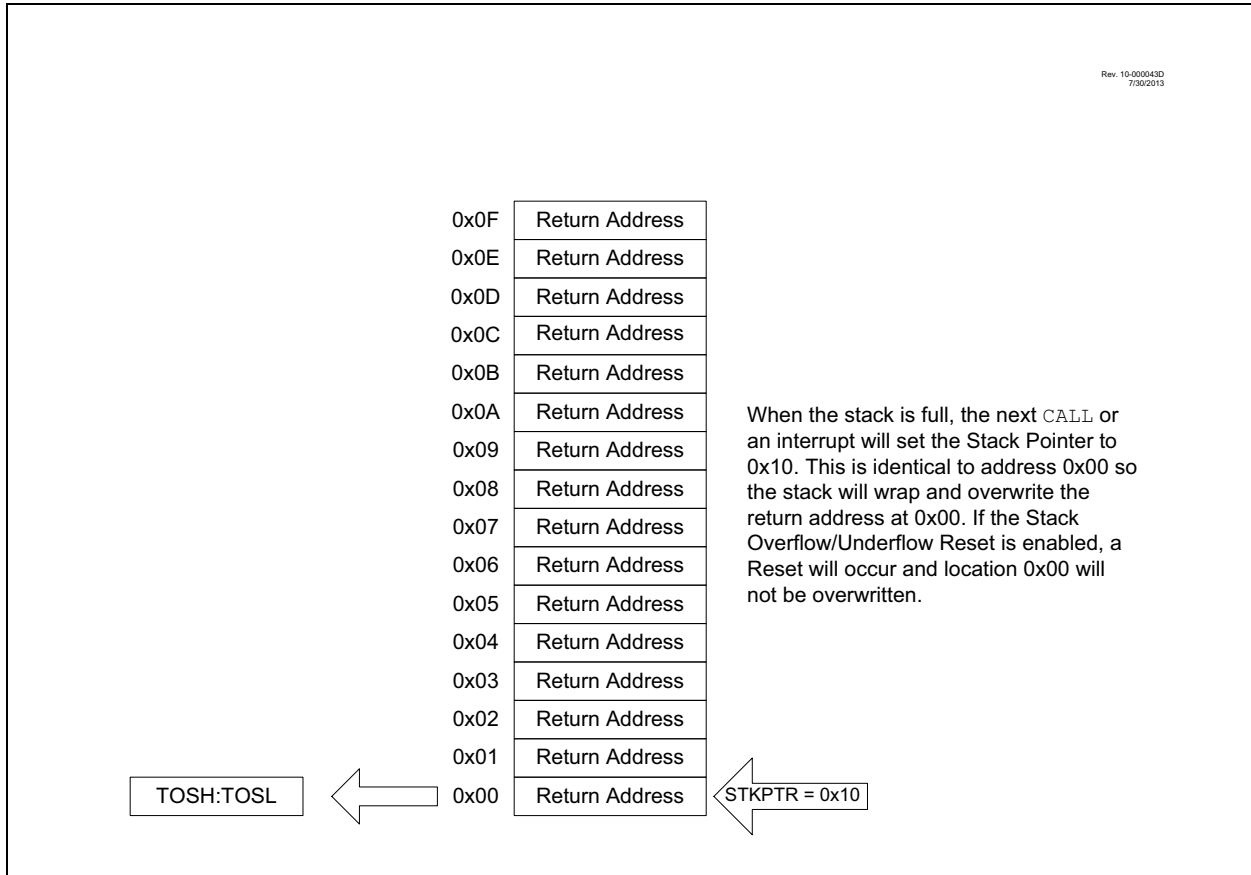

### 3.5.2 OVERFLOW/UNDERFLOW RESET

If the `STVREN` bit in the Configuration Words is programmed to '1', the device will be reset if the stack is `PUSHed` beyond the sixteenth level or `POPed` beyond the first level, setting the appropriate bits (`STKOVF` or `STKUNF`, respectively) in the `PCON` register.

### 3.6 Indirect Addressing

The `INDFn` registers are not physical registers. Any instruction that accesses an `INDFn` register actually accesses the register at the address specified by the File Select Registers (`FSR`). If the `FSRn` address specifies one of the two `INDFn` registers, the read will return '0' and the write will not occur (though Status bits may be affected). The `FSRn` register value is created by the pair, `FSRnH` and `FSRnL`.

The `FSR` registers form a 16-bit address that allows an addressing space with 65536 locations. These locations are divided into three memory regions:

- Traditional Data Memory
- Linear Data Memory
- Program Flash Memory

# PIC12(L)F1571/2

FIGURE 3-9: INDIRECT ADDRESSING

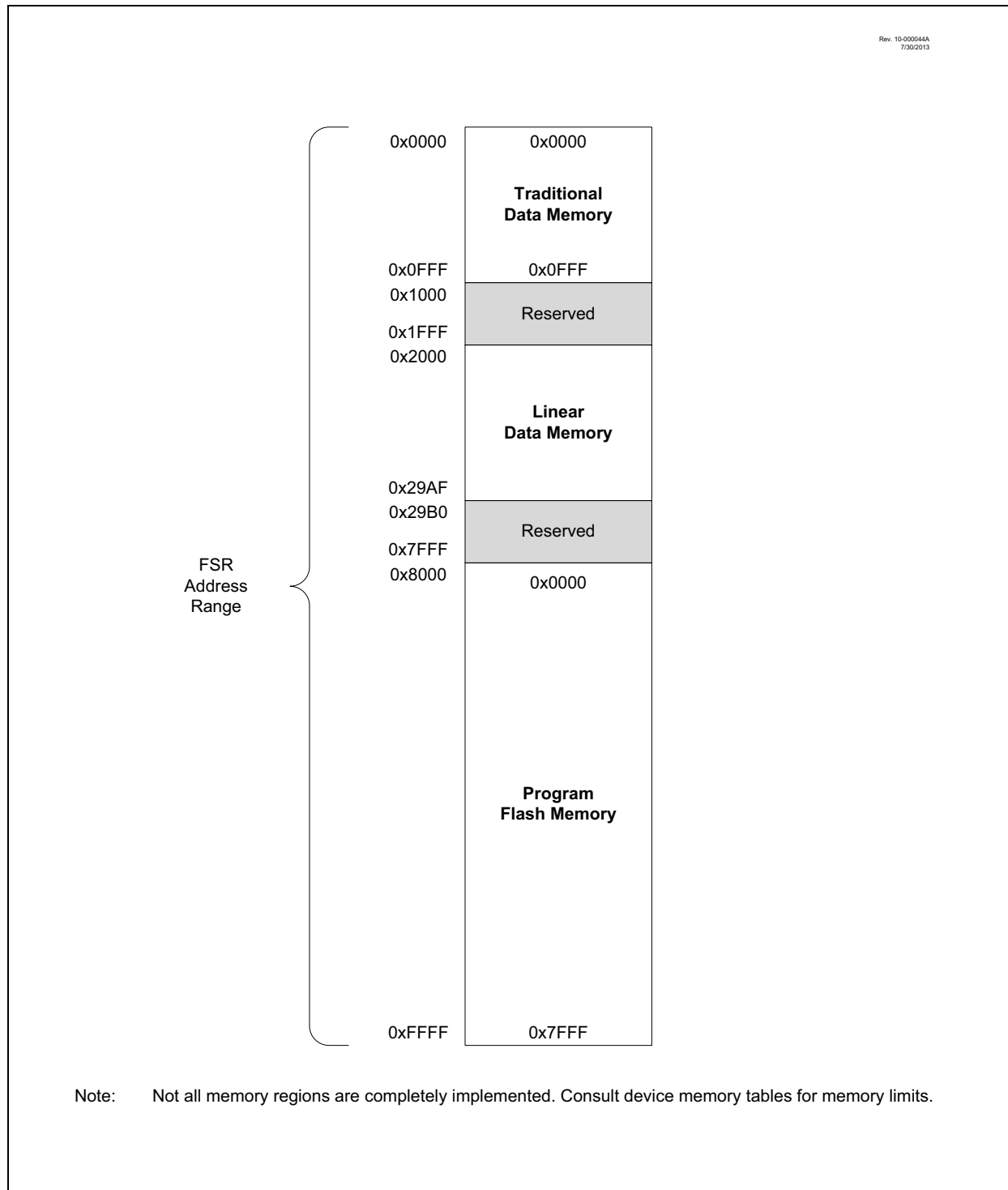

3.6.1 TRADITIONAL DATA MEMORY

The traditional data memory is a region from FSR address, 0x000, to FSR address, 0xFFF. The addresses correspond to the absolute addresses of all SFR, GPR and common registers.

FIGURE 3-10: TRADITIONAL DATA MEMORY MAP

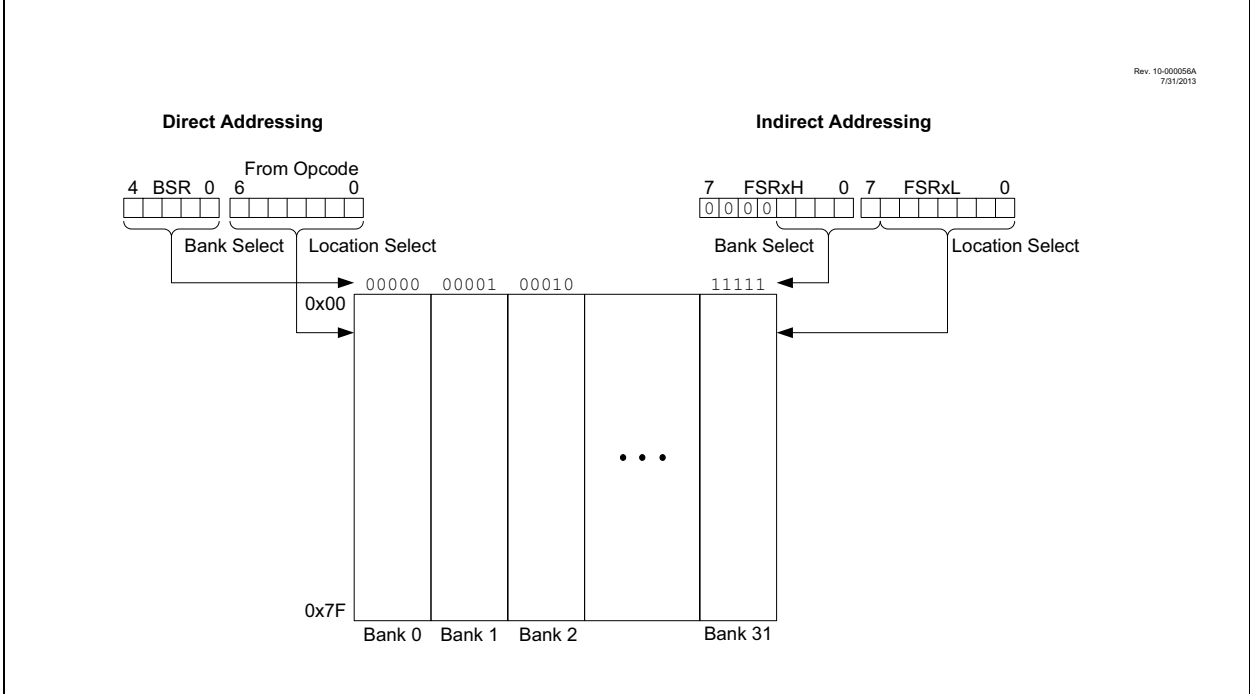

# PIC12(L)F1571/2

## 3.6.2 LINEAR DATA MEMORY

The linear data memory is the region from FSR address, 0x2000, to FSR address, 0x29AF. This region is a virtual region that points back to the 80-byte blocks of GPR memory in all the banks.

Unimplemented memory reads as 0x00. Use of the linear data memory region allows buffers to be larger than 80 bytes because incrementing the FSR beyond one bank will go directly to the GPR memory of the next bank.

The 16 bytes of common memory are not included in the linear data memory region.

**FIGURE 3-11: LINEAR DATA MEMORY MAP**

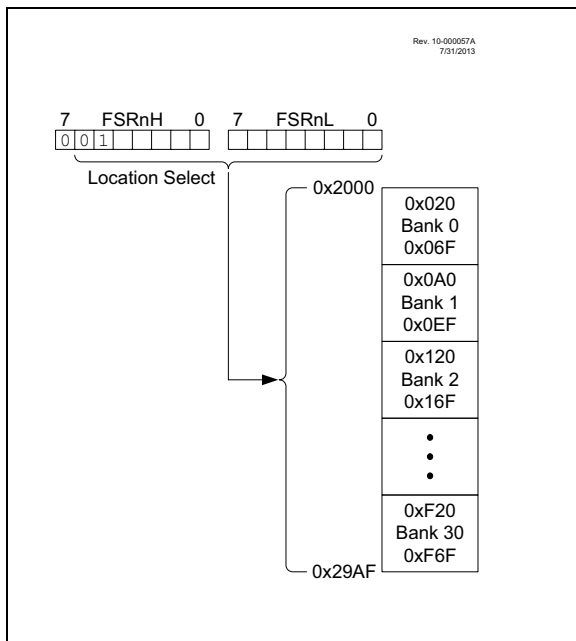

## 3.6.3 PROGRAM FLASH MEMORY

To make constant data access easier, the entire Program Flash Memory is mapped to the upper half of the FSR address space. When the MSb of FSRnH is set, the lower 15 bits are the address in program memory which will be accessed through INDF. Only the lower eight bits of each memory location are accessible via INDF. Writing to the Program Flash Memory cannot be accomplished via the FSR/INDF interface. All instructions that access Program Flash Memory via the FSR/INDF interface will require one additional instruction cycle to complete.

**FIGURE 3-12: PROGRAM FLASH MEMORY MAP**

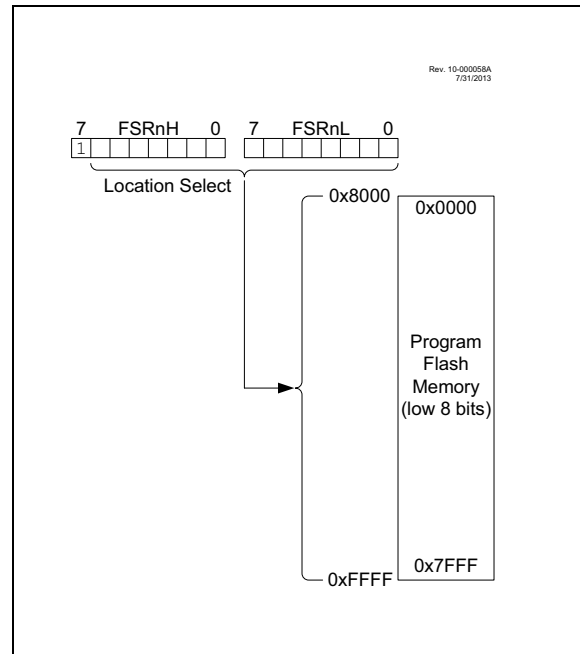



## 4.0 DEVICE CONFIGURATION

Device configuration consists of Configuration Words, code protection and Device ID.

### 4.1 Configuration Words

There are several Configuration Word bits that allow different oscillator and memory protection options. These are implemented as Configuration Word 1 at 8007h and Configuration Word 2 at 8008h.

**Note:** The  $\overline{\text{DEBUG}}$  bit in the Configuration Words is managed automatically by device development tools, including debuggers and programmers. For normal device operation, this bit should be maintained as a '1'.

# PIC12(L)F1571/2

## 4.2 Register Definitions: Configuration Words

### REGISTER 4-1: CONFIG1: CONFIGURATION WORD 1

U-1	U-1	R/P-1	R/P-1	R/P-1	U-1
—	—	$\overline{\text{CLKOUTEN}}$	$\text{BOREN}<1:0>^{(1)}$		—
bit 13					bit 8

R/P-1	R/P-1	R/P-1	R/P-1	R/P-1	U-1	R/P-1	R/P-1
$\overline{\text{CP}}^{(2)}$	$\overline{\text{MCLR}}$	$\overline{\text{PWRT}}^{(1)}$	$\text{WDTE}<1:0>$		—	$\text{FOSC}<1:0>$	
bit 7							bit 0

#### Legend:

R = Readable bit	P = Programmable bit	U = Unimplemented bit, read as '1'
'0' = Bit is cleared	'1' = Bit is set	n = Value when blank or after bulk erase

bit 13-12 **Unimplemented:** Read as '1'

bit 11 **CLKOUTEN:** Clock Out Enable bit

1 = Off – CLKOUT function is disabled; I/O or oscillator function on CLKOUT pin  
 0 = On – CLKOUT function is enabled on CLKOUT pin

bit 10-9 **BOREN<1:0>:** Brown-out Reset Enable bits<sup>(1)</sup>

11 = On – Brown-out Reset is enabled; the SBOREN bit is ignored  
 10 = Sleep – Brown-out Reset is enabled while running and disabled in Sleep; the SBOREN bit is ignored  
 01 = SBODEN – Brown-out Reset is controlled by the SBOREN bit in the BORCON register  
 00 = Off – Brown-out Reset is disabled; the SBOREN bit is ignored

bit 8 **Unimplemented:** Read as '1'

bit 7 **CP:** Flash Program Memory Code Protection bit<sup>(2)</sup>

1 = Off – Code protection is off; program memory can be read and written  
 0 = On – Code protection is on; program memory cannot be read or written externally

bit 6 **MCLR:**  $\overline{\text{MCLR}}/\text{VPP}$  Pin Function Select bit

If LVP bit = 1 (On):

This bit is ignored.  $\overline{\text{MCLR}}/\text{VPP}$  pin function is  $\overline{\text{MCLR}}$ ; weak pull-up is enabled.

If LVP bit = 0 (Off):

1 = On –  $\overline{\text{MCLR}}/\text{VPP}$  pin function is  $\overline{\text{MCLR}}$ ; weak pull-up is enabled

0 = Off –  $\overline{\text{MCLR}}/\text{VPP}$  pin function is a digital input,  $\overline{\text{MCLR}}$  is internally disabled; weak pull-up is under control of pin's WPU control bit

bit 5 **PWRT:** Power-up Timer Enable bit<sup>(1)</sup>

1 = Off – PWRT is disabled  
 0 = On – PWRT is enabled

bit 4-3 **WDTE<1:0>:** Watchdog Timer Enable bits

11 = On – WDT is enabled; SWDTEN is ignored  
 10 = Sleep – WDT is enabled while running and disabled in Sleep; SWDTEN is ignored  
 01 = SWDTEN – WDT is controlled by the SWDTEN bit in the WDTCN register  
 00 = Off – WDT is disabled; SWDTEN is ignored

bit 2 **Unimplemented:** Read as '1'

bit 1-0 **FOSC<1:0>:** Oscillator Selection bits

11 = ECH – External Clock, High-Power mode: CLKI on CLKI  
 10 = ECM – External Clock, Medium Power mode: CLKI on CLKI  
 01 = ECL – External Clock, Low-Power mode: CLKI on CLKI  
 00 = INTOSC – I/O function on CLKI

**Note 1:** Enabling Brown-out Reset does not automatically enable the Power-up Timer.

**Note 2:** Once enabled, code-protect can only be disabled by bulk erasing the device.

## REGISTER 4-2: CONFIG2: CONFIGURATION WORD 2

R/P-1	R/P-1	R/P-1	R/P-1	R/P-1	R/P-1
LVP <sup>(1)</sup>	DEBUG <sup>(2)</sup>	LPBOREN	BORV <sup>(3)</sup>	STVREN	PLLEN
bit 13					bit 8

U-1	U-1	U-1	U-1	U-1	U-1	R/P-1	R/P-1
—	—	—	—	—	—	WRT<1:0>	
bit 7							bit 0

### Legend:

R = Readable bit                      P = Programmable bit                      U = Unimplemented bit, read as '1'  
 '0' = Bit is cleared                      '1' = Bit is set                                      n = Value when blank or after bulk erase

- bit 13        **LVP:** Low-Voltage Programming Enable bit<sup>(1)</sup>  
 1 = On – Low-voltage programming is enabled,  $\overline{\text{MCLR}}/\text{VPP}$  pin function is  $\overline{\text{MCLR}}$ ; MCLR Configuration bit is ignored  
 0 = Off – High voltage on  $\overline{\text{MCLR}}/\text{VPP}$  must be used for programming
- bit 12        **DEBUG:** Debugger Mode bit<sup>(2)</sup>  
 1 = Off – In-Circuit Debugger is disabled; ICSPCLK and ICSPDAT are general purpose I/O pins  
 0 = On – In-Circuit Debugger is enabled; ICSPCLK and ICSPDAT are dedicated to the debugger
- bit 11        **LPBOREN:** Low-Power Brown-out Reset Enable bit  
 1 = Off – Low-power Brown-out Reset is disabled  
 0 = On – Low-power Brown-out Reset is enabled
- bit 10        **BORV:** Brown-out Reset Voltage Selection bit<sup>(3)</sup>  
 1 = Low – Brown-out Reset voltage ( $V_{BOR}$ ), low trip point selected  
 0 = High – Brown-out Reset voltage ( $V_{BOR}$ ), high trip point selected
- bit 9         **STVREN:** Stack Overflow/Underflow Reset Enable bit  
 1 = On – Stack overflow or underflow will cause a Reset  
 0 = Off – Stack overflow or underflow will not cause a Reset
- bit 8         **PLLEN:** PLL Enable bit  
 1 = On – 4xPLL is enabled  
 0 = Off – 4xPLL is disabled
- bit 7-2       **Unimplemented:** Read as '1'
- bit 1-0       **WRT<1:0>:** Flash Memory Self-Write Protection bits  
2 kW Flash Memory (PIC12F1572):  
 11 = Off – Write protection is off  
 10 = Boot – 000h to 1FFh is write-protected, 200h to 7FFh may be modified by PMCON control  
 01 = Half – 000h to 3FFh is write-protected, 400h to 7FFh may be modified by PMCON control  
 00 = All – 000h to 7FFh is write-protected, no addresses may be modified by PMCON control  
1 kW Flash Memory (PIC12(L)F1571):  
 11 = Off – Write protection is off  
 10 = Boot – 000h to 0FFh is write-protected, 100h to 3FFh may be modified by PMCON control  
 01 = Half – 000h to 1FFh is write-protected, 200h to 3FFh may be modified by PMCON control  
 00 = All – 000h to 3FFh is write-protected, no addresses may be modified by PMCON control

- Note 1:** This bit cannot be programmed to '0' when programming mode is entered via LVP.  
**2:** The DEBUG bit in Configuration Words is managed automatically by device development tools, including debuggers and programmers. For normal device operation, this bit should be maintained as a '1'.  
**3:** See  $V_{BOR}$  parameter for specific trip point voltages.

## 4.3 Code Protection

Code protection allows the device to be protected from unauthorized access. Internal access to the program memory is unaffected by any code protection setting.

### 4.3.1 PROGRAM MEMORY PROTECTION

The entire program memory space is protected from external reads and writes by the  $\overline{CP}$  bit in the Configuration Words. When  $\overline{CP} = 0$ , external reads and writes of program memory are inhibited and a read will return all '0's. The CPU can continue to read program memory, regardless of the protection bit settings. Writing the program memory is dependent upon the write protection setting. See [Section 4.4 "Write Protection"](#) for more information.

## 4.4 Write Protection

Write protection allows the device to be protected from unintended self-writes. Applications, such as boot-loader software, can be protected while allowing other regions of the program memory to be modified.

The WRT<1:0> bits in the Configuration Words define the size of the program memory block that is protected.

## 4.5 User ID

Four memory locations (8000h-8003h) are designated as ID locations where the user can store checksum or other code identification numbers. These locations are readable and writable during normal execution. See [Section 10.4 "User ID, Device ID and Configuration Word Access"](#) for more information on accessing these memory locations. For more information on checksum calculation, see the *"PIC12(L)F1571/2 Memory Programming Specification"* (DS40001713).

## 4.6 Device ID and Revision ID

The 14-bit Device ID word is located at 8006h and the 14-bit Revision ID is located at 8005h. These locations are read-only and cannot be erased or modified. See [Section 10.4 "User ID, Device ID and Configuration Word Access"](#) for more information on accessing these memory locations.

Development tools, such as device programmers and debuggers, may be used to read the Device ID and Revision ID.

## 4.7 Register Definitions: Device ID

### REGISTER 4-3: DEVICEID: DEVICE ID REGISTER<sup>(1)</sup>

R	R	R	R	R	R
DEV<13:8>					
bit 13			bit 8		

R	R	R	R	R	R	R	R
DEV<7:0>							
bit 7				bit 0			

**Legend:**

R = Readable bit

'0' = Bit is cleared

'1' = Bit is set

x = Bit is unknown

bit 13-0 **DEV<13:0>**: Device ID bits

Refer to [Table 4-1](#) to determine what these bits will read on which device. A value of 3FFFh is invalid.

**Note 1:** This location cannot be written.

### REGISTER 4-4: REVISIONID: REVISION ID REGISTER<sup>(1)</sup>

R	R	R	R	R	R
REV<13:8>					
bit 13			bit 8		

R	R	R	R	R	R	R	R
REV<7:0>							
bit 7				bit 0			

**Legend:**

R = Readable bit

'0' = Bit is cleared

'1' = Bit is set

x = Bit is unknown

bit 13-0 **REV<13:0>**: Revision ID bits

These bits are used to identify the device revision.

**Note 1:** This location cannot be written.

**TABLE 4-1: DEVICE ID VALUES**

DEVICE	Device ID	Revision ID
PIC12F1571	3051h	2xxxh
PIC12LF1571	3053h	2xxxh
PIC12F1572	3050h	2xxxh
PIC12LF1572	3052h	2xxxh

# PIC12(L)F1571/2

---

NOTES:

## 5.0 OSCILLATOR MODULE

### 5.1 Overview

The oscillator module has a wide variety of clock sources and selection features that allow it to be used in a wide range of applications, while maximizing performance and minimizing power consumption. [Figure 5-1](#) illustrates a block diagram of the oscillator module.

Clock sources can be supplied from external oscillators, quartz crystal resonators, ceramic resonators and Resistor-Capacitor (RC) circuits. In addition, the system clock source can be supplied from one of two internal oscillators and PLL circuits, with a choice of speeds selectable via software. Additional clock features include:

- Selectable system clock source between external or internal sources via software
- Oscillator Start-up Timer (OST) ensures stability of crystal oscillator sources

The oscillator module can be configured in one of the following clock modes:

1. ECL – External Clock Low-Power mode (0 MHz to 0.5 MHz)
2. ECM – External Clock Medium Power mode (0.5 MHz to 4 MHz)
3. ECH – External Clock High-Power mode (4 MHz to 32 MHz)
4. INTOSC – Internal Oscillator (31 kHz to 32 MHz)

Clock Source modes are selected by the FOSC<1:0> bits in the Configuration Words. The FOSC bits determine the type of oscillator that will be used when the device is first powered.

The ECH, ECM, and ECL Clock modes rely on an external logic level signal as the device clock source.

The INTOSC internal oscillator block produces low, medium and high-frequency clock sources, designated as LFINTOSC, MFINTOSC and HFINTOSC (see Internal Oscillator Block, [Figure 5-1](#)). A wide selection of device clock frequencies may be derived from these three clock sources.

# PIC12(L)F1571/2

**FIGURE 5-1: SIMPLIFIED PIC® MCU CLOCK SOURCE BLOCK DIAGRAM**

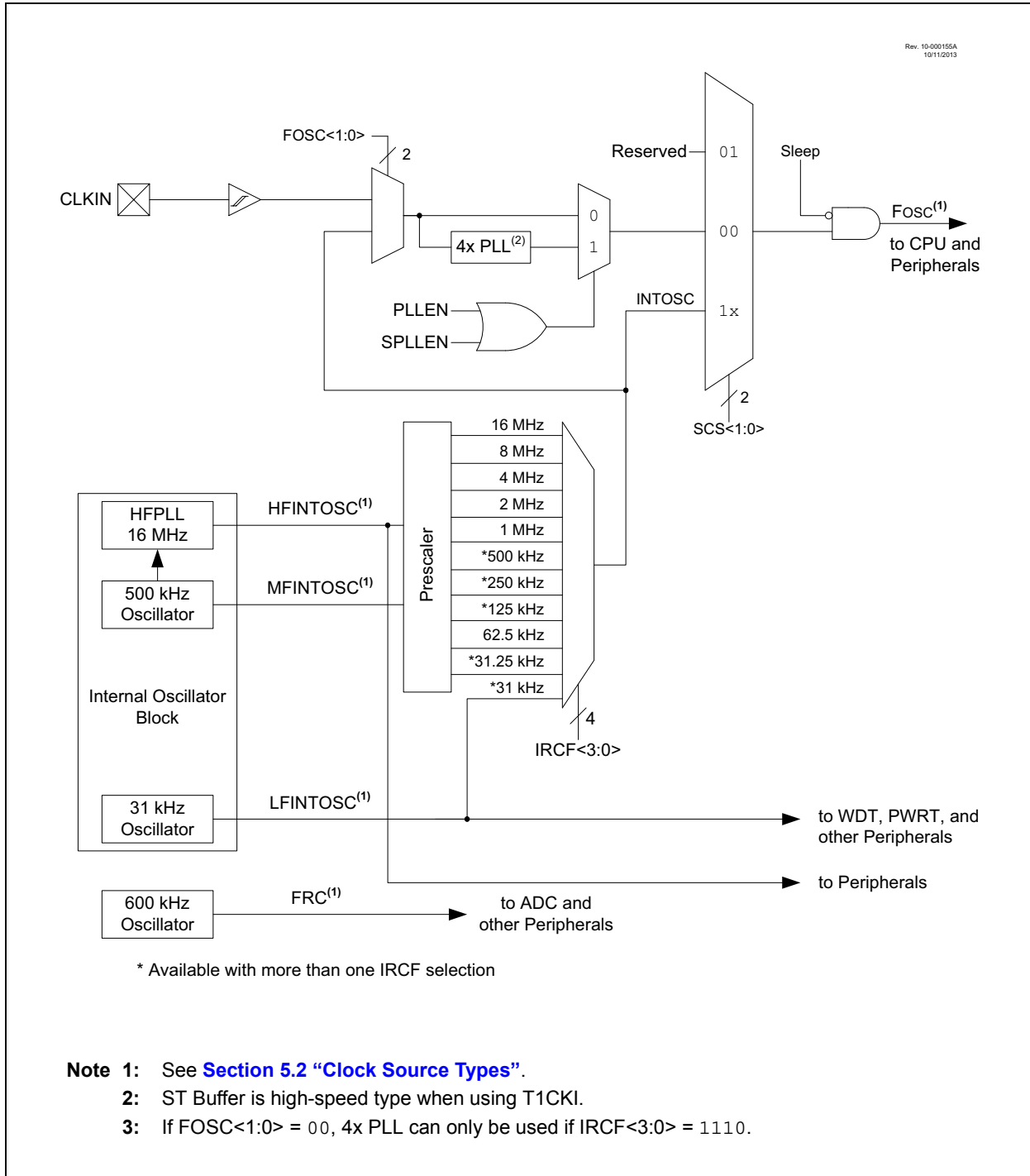



## 5.2 Clock Source Types

Clock sources can be classified as external or internal.

External clock sources rely on external circuitry for the clock source to function.

Internal clock sources are contained within the oscillator module. The internal oscillator block has two internal oscillators and a dedicated Phase-Locked Loop (HFPLL) that are used to generate three internal system clock sources: the 16 MHz High-Frequency Internal Oscillator (HFINTOSC), 500 kHz Medium Frequency Internal Oscillator (MFINTOSC) and the 31 kHz Low-Frequency Internal Oscillator (LFINTOSC).

The system clock can be selected between external or internal clock sources via the System Clock Select (SCS<1:0>) bits in the OSCCON register. See [Section 5.3 “Clock Switching”](#) for additional information.

### 5.2.1 EXTERNAL CLOCK SOURCES

An external clock source can be used as the device system clock by performing one of the following actions:

- Program the FOSC<1:0> bits in the Configuration Words to select an external clock source that will be used as the default system clock upon a device Reset.
- Write the SCS<1:0> bits in the OSCCON register to switch the system clock source to:
  - Timer1 oscillator during run time, or
  - An external clock source determined by the value of the FOSCx bits.

See [Section 5.3 “Clock Switching”](#) for more information.

#### 5.2.1.1 EC Mode

The External Clock (EC) mode allows an externally generated logic level signal to be the system clock source. When operating in this mode, an external clock source is connected to the CLKIN input. CLKOUT is available for general purpose I/Os or CLKOUT. [Figure 5-2](#) shows the pin connections for EC mode.

EC mode has three power modes to select from through the FOSCx bits in the Configuration Words:

- ECH – High power, 4-20 MHz
- ECM – Medium power, 0.5-4 MHz
- ECL – Low power, 0-0.5 MHz

The Oscillator Start-up Timer (OST) is disabled when EC mode is selected. Therefore, there is no delay in operation after a Power-on Reset (POR) or wake-up from Sleep. Because the PIC® MCU design is fully static, stopping the external clock input will have the effect of halting the device while leaving all data intact. Upon restarting the external clock, the device will resume operation as if no time had elapsed.

**FIGURE 5-2: EXTERNAL CLOCK (EC) MODE OPERATION**

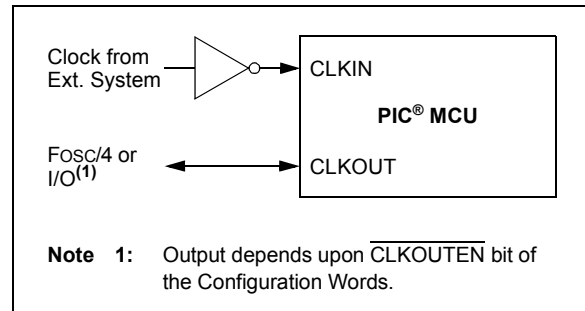

# PIC12(L)F1571/2

## 5.2.2 INTERNAL CLOCK SOURCES

The device may be configured to use the internal oscillator block as the system clock by performing one of the following actions:

- Program the FOSC<1:0> bits in the Configuration Words to select the INTOSC clock source, which will be used as the default system clock upon a device Reset.
- Write the SCS<1:0> bits in the OSCCON register to switch the system clock source to the internal oscillator during run time. See [Section 5.3 “Clock Switching”](#) for more information.

In **INTOSC** mode, CLKIN is available for general purpose I/O. CLKOUT is available for general purpose I/O or CLKOUT.

The function of the OSC2/CLKOUT pin is determined by the CLKOUTEN bit in the Configuration Words.

The internal oscillator block has two independent oscillators and a dedicated Phase-Locked Loop, HFPLL, that can produce one of three internal system clock sources.

1. The **HFINTOSC** (High-Frequency Internal Oscillator) is factory calibrated and operates at 16 MHz. The HFINTOSC source is generated from the 500 kHz MFINTOSC source and the dedicated Phase-Locked Loop, HFPLL. The frequency of the HFINTOSC can be user-adjusted via software using the OSCTUNE register ([Register 5-3](#)).
2. The **MFINTOSC** (Medium Frequency Internal Oscillator) is factory calibrated and operates at 500 kHz. The frequency of the MFINTOSC can be user-adjusted via software using the OSCTUNE register ([Register 5-3](#)).
3. The **LFINTOSC** (Low-Frequency Internal Oscillator) is uncalibrated and operates at 31 kHz.

### 5.2.2.1 HFINTOSC

The High-Frequency Internal Oscillator (HFINTOSC) is a factory calibrated 16 MHz internal clock source. The frequency of the HFINTOSC can be altered via software using the OSCTUNE register ([Register 5-3](#)).

The output of the HFINTOSC connects to a postscaler and multiplexer (see [Figure 5-1](#)). One of multiple frequencies derived from the HFINTOSC can be selected via software using the IRCF<3:0> bits of the OSCCON register. See [Section 5.2.2.8 “Internal Oscillator Clock Switch Timing”](#) for more information.

The HFINTOSC is enabled by:

- Configuring the IRCF<3:0> bits of the OSCCON register for the desired HF frequency, and
- Setting FOSC<1:0> = 00, or
- Setting the System Clock Source x (SCSx) bits of the OSCCON register to ‘1x’.

A fast start-up oscillator allows internal circuits to power up and stabilize before switching to HFINTOSC.

The High-Frequency Internal Oscillator Ready bit (HFIOFR) of the OSCSTAT register indicates when the HFINTOSC is running.

The High-Frequency Internal Oscillator Status Locked bit (HFIOFL) of the OSCSTAT register indicates when the HFINTOSC is running within 2% of its final value.

The High-Frequency Internal Oscillator Stable bit (HFIOFS) of the OSCSTAT register indicates when the HFINTOSC is running within 0.5% of its final value.

### 5.2.2.2 MFINTOSC

The Medium Frequency Internal Oscillator (MFINTOSC) is a factory calibrated 500 kHz internal clock source. The frequency of the MFINTOSC can be altered via software using the OSCTUNE register ([Register 5-3](#)).

The output of the MFINTOSC connects to a postscaler and multiplexer (see [Figure 5-1](#)). One of nine frequencies derived from the MFINTOSC can be selected via software using the IRCF<3:0> bits of the OSCCON register. See [Section 5.2.2.8 “Internal Oscillator Clock Switch Timing”](#) for more information.

The MFINTOSC is enabled by:

- Configuring the IRCF<3:0> bits of the OSCCON register for the desired HF frequency, and
- Setting FOSC<1:0> = 00, or
- Setting the System Clock Source x (SCSx) bits of the OSCCON register to ‘1x’.

The Medium Frequency Internal Oscillator Ready bit (MFIOFR) of the OSCSTAT register indicates when the MFINTOSC is running.

## 5.2.2.3 Internal Oscillator Frequency Adjustment

The 500 kHz internal oscillator is factory calibrated. This internal oscillator can be adjusted in software by writing to the OSCTUNE register ([Register 5-3](#)). Since the HFINTOSC and MFINTOSC clock sources are derived from the 500 kHz internal oscillator, a change in the OSCTUNE register value will apply to both.

The default value of the OSCTUNE register is '0'. The value is a 6-bit two's complement number. A value of 1Fh will provide an adjustment to the maximum frequency. A value of 20h will provide an adjustment to the minimum frequency.

When the OSCTUNE register is modified, the oscillator frequency will begin shifting to the new frequency. Code execution continues during this shift. There is no indication that the shift has occurred.

OSCTUNE does not affect the LFINTOSC frequency. Operation of features that depends on the LFINTOSC clock source frequency, such as the Power-up Timer (PWRT), Watchdog Timer (WDT) and peripherals, are *not* affected by the change in frequency.

## 5.2.2.4 LFINTOSC

The Low-Frequency Internal Oscillator (LFINTOSC) is an uncalibrated 31 kHz internal clock source.

The output of the LFINTOSC connects to a multiplexer (see [Figure 5-1](#)). Select 31 kHz, via software, using the IRCF<3:0> bits of the OSCCON register. See [Section 5.2.2.8 "Internal Oscillator Clock Switch Timing"](#) for more information. The LFINTOSC is also the frequency for the Power-up Timer (PWRT), Watchdog Timer (WDT) and Fail-Safe Clock Monitor (FSCM).

The LFINTOSC is enabled by selecting 31 kHz (IRCF<3:0> (OSCCON<6:3>) = 0000) as the system clock source (SCS<1:0> (OSCCON<1:0>) = 1x) or when any of the following are enabled:

- Configure the IRCF<3:0> bits of the OSCCON register for the desired LF frequency, and
- Set FOSC<1:0> = 00, or
- Set the System Clock Source x (SCSx) bits of the OSCCON register to '1x'

Peripherals that use the LFINTOSC are:

- Power-up Timer (PWRT)
- Watchdog Timer (WDT)

The Low-Frequency Internal Oscillator Ready bit (LFIOFR) of the OSCSTAT register indicates when the LFINTOSC is running.

## 5.2.2.5 FRC

The FRC clock is an uncalibrated, nominal 600 kHz peripheral clock source.

The FRC is automatically turned on by the peripherals requesting the FRC clock.

The FRC clock will continue to run during Sleep.

## 5.2.2.6 Internal Oscillator Frequency Selection

The system clock speed can be selected via software using the Internal Oscillator Frequency Select bits IRCF<3:0> of the OSCCON register.

The postscaler outputs of the 16 MHz HFINTOSC, **500 kHz MFINTOSC** and **31 kHz LFINTOSC** output connect to a multiplexer (see [Figure 5-1](#)). The Internal Oscillator Frequency Select bits, IRCF<3:0> of the OSCCON register, select the frequency output of the internal oscillators. One of the following frequencies can be selected via software:

- 32 MHz (requires 4x PLL)
- 16 MHz
- 8 MHz
- 4 MHz
- 2 MHz
- 1 MHz
- 500 kHz (default after Reset)
- 250 kHz
- 125 kHz
- 62.5 kHz
- 31.25 kHz
- 31 kHz (LFINTOSC)

**Note:** Following any Reset, the IRCF<3:0> bits of the OSCCON register are set to '0111' and the frequency selection is set to 500 kHz. The user can modify the IRCF<sub>x</sub> bits to select a different frequency.

The IRCF<3:0> bits of the OSCCON register allow duplicate selections for some frequencies. These duplicate choices can offer system design trade-offs. Lower power consumption can be obtained when changing oscillator sources for a given frequency. Faster transition times can be obtained between frequency changes that use the same oscillator source.

# PIC12(L)F1571/2

---

## 5.2.2.7 32 MHz Internal Oscillator Frequency Selection

The internal oscillator block can be used with the 4x PLL associated with the external oscillator block to produce a 32 MHz internal system clock source. The following settings are required to use the 32 MHz internal clock source:

- The FOSC<sub>x</sub> bits in the Configuration Words must be set to use the INTOSC source as the device system clock (FOSC<1:0> = 00).
- The SCS<sub>x</sub> bits in the OSCCON register must be cleared to use the clock determined by FOSC<1:0> in the Configuration Words (SCS<1:0> = 00).
- The IRCF<sub>x</sub> bits in the OSCCON register must be set to the 8 MHz HFINTOSC to use (IRCF<3:0> = 1110).
- The SPLEN bit in the OSCCON register must be set to enable the 4x PLL or the PLEN bit of the Configuration Words must be programmed to a '1'.

**Note:** When using the PLEN bit of the Configuration Words, the 4x PLL cannot be disabled by software and the 8 MHz HFINTOSC option will no longer be available.

The 4x PLL is not available for use with the internal oscillator when the SCS<sub>x</sub> bits of the OSCCON register are set to '1x'. The SCS<sub>x</sub> bits must be set to '00' to use the 4x PLL with the internal oscillator.

## 5.2.2.8 Internal Oscillator Clock Switch Timing

When switching between the HFINTOSC, MFINTOSC and the LFINTOSC, the new oscillator may already be shut down to save power (see [Figure 5-3](#)). If this is the case, there is a delay after the IRCF<3:0> bits of the OSCCON register are modified before the frequency selection takes place. The OSCSTAT register will reflect the current active status of the HFINTOSC, MFINTOSC and LFINTOSC oscillators. The sequence of a frequency selection is as follows:

1. IRCF<3:0> bits of the OSCCON register are modified.
2. If the new clock is shut down, a clock start-up delay is started.
3. Clock switch circuitry waits for a falling edge of the current clock.
4. The current clock is held low and the clock switch circuitry waits for a rising edge in the new clock.
5. The new clock is now active.
6. The OSCSTAT register is updated as required.
7. Clock switch is complete.

See [Figure 5-3](#) for more details.

If the internal oscillator speed is switched between two clocks of the same source, there is no start-up delay before the new frequency is selected. Clock switching time delays are shown in [Table 5-1](#).

Start-up delay specifications are located in the oscillator tables of [Section 26.0 "Electrical Specifications"](#).

FIGURE 5-3: INTERNAL OSCILLATOR SWITCH TIMING

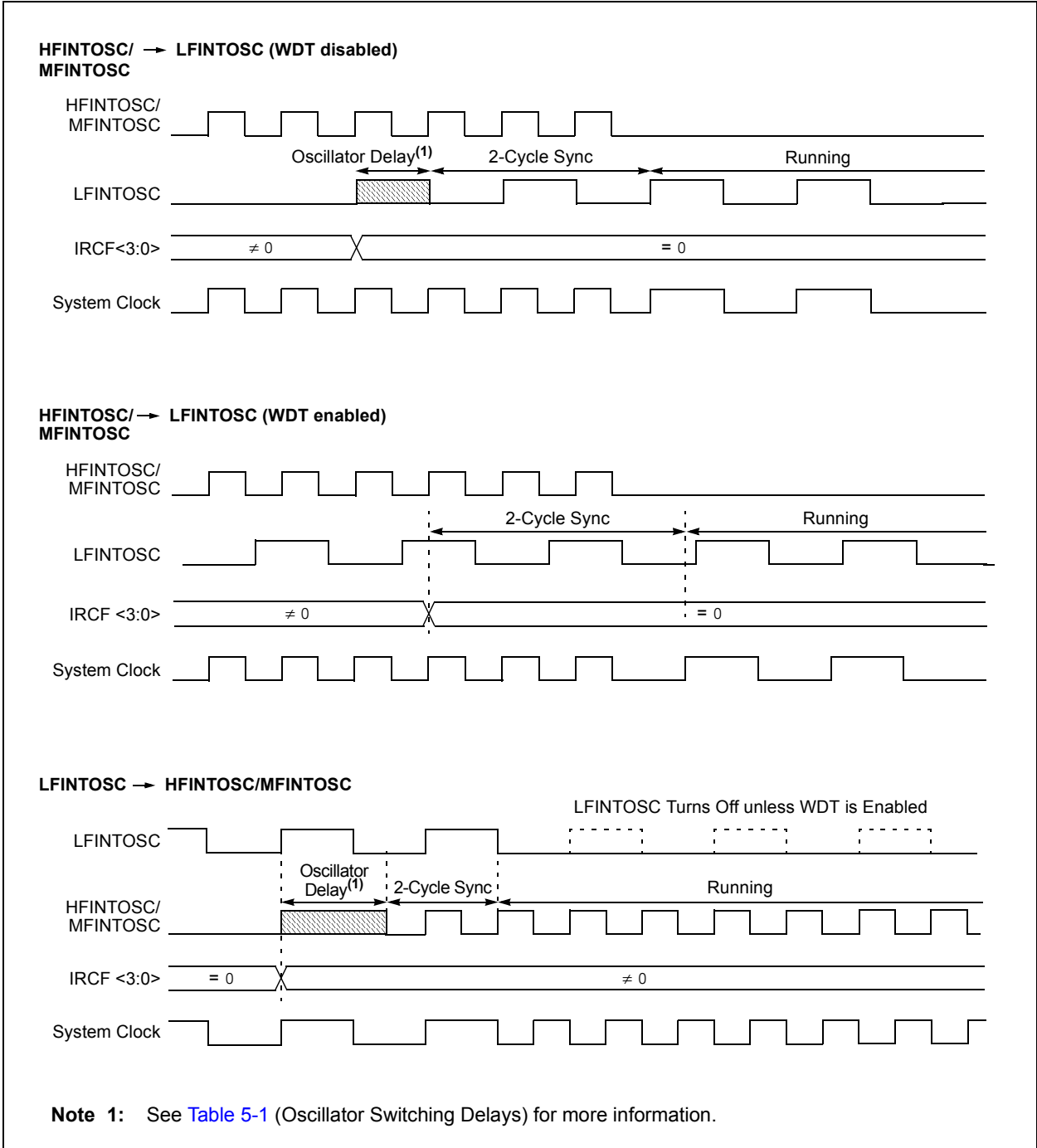

# PIC12(L)F1571/2

## 5.3 Clock Switching

The system clock source can be switched between external and internal clock sources via software using the System Clock Select (SCSx) bits of the OSCCON register. The following clock sources can be selected using the SCSx bits:

- Default system oscillator determined by FOSCx bits in the Configuration Words
- Timer1 32 kHz crystal oscillator
- Internal Oscillator Block (INTOSC)

### 5.3.1 SYSTEM CLOCK SELECT (SCSx) BITS

The System Clock Select (SCSx) bits of the OSCCON register select the system clock source that is used for the CPU and peripherals.

- When the SCSx bits of the OSCCON register = 00, the system clock source is determined by the value of the FOSC<1:0> bits in the Configuration Words.
- When the SCSx bits of the OSCCON register = 01, the system clock source is the Timer1 oscillator.
- When the SCSx bits of the OSCCON register = 1x, the system clock source is chosen by the internal oscillator frequency selected by the IRCF<3:0> bits of the OSCCON register. After a Reset, the SCSx bits of the OSCCON register are always cleared.

**Note:** Any automatic clock switch does not update the SCSx bits of the OSCCON register. The user can monitor the OSTS bit of the OSCSTAT register to determine the current system clock source.

When switching between clock sources, a delay is required to allow the new clock to stabilize. These oscillator delays are shown in [Table 5-1](#).

## 5.4 Clock Switching Before Sleep

When clock switching from an old clock to a new clock is requested, just prior to entering Sleep mode, it is necessary to confirm that the switch is complete before the SLEEP instruction is executed. Failure to do so may result in an incomplete switch and consequential loss of the system clock altogether. Clock switching is confirmed by monitoring the clock status bits in the OSCSTAT register. Switch confirmation can be accomplished by sensing that the ready bit for the new clock is set or the ready bit for the old clock is cleared. For example, when switching between the internal oscillator with the PLL and the internal oscillator without the PLL, monitor the PLLR bit. When PLLR is set, the switch to 32 MHz operation is complete. Conversely, when PLLR is cleared, the switch from 32 MHz operation to the selected internal clock is complete.

**TABLE 5-1: OSCILLATOR SWITCHING DELAYS**

Switch From	Switch To	Frequency	Oscillator Delay
Sleep/POR	LFINTOSC <sup>(1)</sup> MFINTOSC <sup>(1)</sup> HFINTOSC <sup>(1)</sup>	31 kHz 31.25 kHz-500 kHz 31.25 kHz-16 MHz	Oscillator Warm-up Delay (TWARM) <sup>(2)</sup>
Sleep/POR	EC <sup>(1)</sup>	DC – 32 MHz	2 cycles
LFINTOSC	EC <sup>(1)</sup>	DC – 32 MHz	1 cycle of each
Any Clock Source	MFINTOSC <sup>(1)</sup> HFINTOSC <sup>(1)</sup>	31.25 kHz-500 kHz 31.25 kHz-16 MHz	2 μs (approx.)
Any Clock Source	LFINTOSC <sup>(1)</sup>	31 kHz	1 cycle of each
PLL Inactive	PLL Active	16-32 MHz	2 ms (approx.)

**Note 1:** PLL inactive.

**2:** See [Section 26.0 “Electrical Specifications”](#).

## 5.5 Register Definitions: Oscillator Control

### REGISTER 5-1: OSCCON: OSCILLATOR CONTROL REGISTER

R/W-0/0	R/W-0/0	R/W-1/1	R/W-1/1	R/W-1/1	U-0	R/W-0/0	R/W-0/0
SPLLEN	IRCF<3:0>			—	SCS<1:0>		
bit 7							bit 0

#### Legend:

R = Readable bit	W = Writable bit	
u = Bit is unchanged	x = Bit is unknown	U = Unimplemented bit, read as '0'
'1' = Bit is set	'0' = Bit is cleared	-n/n = Value at POR and BOR/Value at all other Resets

- bit 7      **SPLLEN:** Software PLL Enable bit  
If PLEN in Configuration Words = 1:  
 SPLLEN bit is ignored. 4x PLL is always enabled (subject to oscillator requirements).  
If PLEN in Configuration Words = 0:  
 1 = 4x PLL is enabled  
 0 = 4x PLL is disabled
- bit 6-3    **IRCF<3:0>:** Internal Oscillator Frequency Select bits  
 1111 = 16 MHz HF  
 1110 = 8 MHz or 32 MHz HF (see [Section 5.2.2.1 "HFINTOSC"](#))  
 1101 = 4 MHz HF  
 1100 = 2 MHz HF  
 1011 = 1 MHz HF  
 1010 = 500 kHz HF<sup>(1)</sup>  
 1001 = 250 kHz HF<sup>(1)</sup>  
 1000 = 125 kHz HF<sup>(1)</sup>  
 0111 = 500 kHz MF (default upon Reset)  
 0110 = 250 kHz MF  
 0101 = 125 kHz MF  
 0100 = 62.5 kHz MF  
 0011 = 31.25 kHz HF<sup>(1)</sup>  
 0010 = 31.25 kHz MF  
 000x = 31 kHz LF
- bit 2      **Unimplemented:** Read as '0'
- bit 1-0    **SCS<1:0>:** System Clock Select bits  
 1x = Internal oscillator block  
 01 = Timer1 oscillator  
 00 = Clock determined by FOSC<1:0> in Configuration Words

**Note 1:** Duplicate frequency derived from HFINTOSC.

# PIC12(L)F1571/2

## REGISTER 5-2: OSCSTAT: OSCILLATOR STATUS REGISTER

U-0	R-0/q	R-q/q	R-0/q	R-0/q	R-q/q	R-0/q	R-0/q
—	PLL R	OSTS	HFIOFR	HFIOFL	MFIOFR	LFIOFR	HFIOFS
bit 7							bit 0

### Legend:

R = Readable bit	W = Writable bit	q = Conditional bit
u = Bit is unchanged	x = Bit is unknown	U = Unimplemented bit, read as '0'
'1' = Bit is set	'0' = Bit is cleared	-n/n = Value at POR and BOR/Value at all other Resets

bit 7	<b>Unimplemented:</b> Read as '0'
bit 6	<b>PLL R</b> 4x PLL Ready bit 1 = 4x PLL is ready 0 = 4x PLL is not ready
bit 5	<b>OSTS:</b> Oscillator Start-up Timer Status bit 1 = Running from the clock defined by the FOSC<1:0> bits of the Configuration Words 0 = Running from an internal oscillator (FOSC<1:0> = 00)
bit 4	<b>HFIOFR:</b> High-Frequency Internal Oscillator Ready bit 1 = HFINTOSC is ready 0 = HFINTOSC is not ready
bit 3	<b>HFIOFL:</b> High-Frequency Internal Oscillator Locked bit 1 = HFINTOSC is at least 2% accurate 0 = HFINTOSC is not 2% accurate
bit 2	<b>MFIOFR:</b> Medium Frequency Internal Oscillator Ready bit 1 = MFINTOSC is ready 0 = MFINTOSC is not ready
bit 1	<b>LFIOFR:</b> Low-Frequency Internal Oscillator Ready bit 1 = LFINTOSC is ready 0 = LFINTOSC is not ready
bit 0	<b>HFIOFS:</b> High-Frequency Internal Oscillator Stable bit 1 = HFINTOSC is at least 0.5% accurate 0 = HFINTOSC is not 0.5% accurate



## REGISTER 5-3: OSCTUNE: OSCILLATOR TUNING REGISTER

U-0	U-0	R/W-0/0	R/W-0/0	R/W-0/0	R/W-0/0	R/W-0/0	R/W-0/0
—	—	TUN<5:0>					
bit 7							bit 0

### Legend:

R = Readable bit	W = Writable bit	
u = Bit is unchanged	x = Bit is unknown	U = Unimplemented bit, read as '0'
'1' = Bit is set	'0' = Bit is cleared	-n/n = Value at POR and BOR/Value at all other Resets

bit 7-6      **Unimplemented:** Read as '0'

bit 5-0      **TUN<5:0>:** Frequency Tuning bits  
 100000 = Minimum frequency  
 •  
 •  
 •  
 111111 =  
 000000 = Oscillator module is running at the factory-calibrated frequency  
 000001 =  
 •  
 •  
 •  
 011110 =  
 011111 = Maximum frequency

**TABLE 5-2: SUMMARY OF REGISTERS ASSOCIATED WITH CLOCK SOURCES**

Name	Bit 7	Bit 6	Bit 5	Bit 4	Bit 3	Bit 2	Bit 1	Bit 0	Register on Page
OSCCON	SPLLEN	IRCF<3:0>				—	SCS<1:0>		55
OSCSTAT	—	PLLR	OSTS	HFIOFR	HFIOFL	MFIOFR	LFIOFR	HFIOFS	56
OSCTUNE	—	—	TUN<5:0>						57
T1CON	TMR1CS<1:0>		T1CKPS<1:0>		—	T1SYNC	—	TMR1ON	167

**Legend:** — = unimplemented location, read as '0'. Shaded cells are not used by clock sources.

**TABLE 5-3: SUMMARY OF CONFIGURATION WORD WITH CLOCK SOURCES**

Name	Bits	Bit -/7	Bit -/6	Bit 13/5	Bit 12/4	Bit 11/3	Bit 10/2	Bit 9/1	Bit 8/0	Register on Page
CONFIG1	13:8	—	—	—	—	CLKOUTEN	BOREN<1:0>		—	42
	7:0	CP	MCLRE	PWRTE	WDTE<1:0>		—	FOSC<1:0>		

**Legend:** — = unimplemented location, read as '0'. Shaded cells are not used by clock sources.

# PIC12(L)F1571/2

---

NOTES:

## 6.0 RESETS

There are multiple ways to reset this device:

- Power-on Reset (POR)
- Brown-out Reset (BOR)
- Low-Power Brown-out Reset (LPBOR)
- MCLR Reset
- WDT Reset
- RESET instruction
- Stack Overflow
- Stack Underflow
- Programming mode exit

To allow VDD to stabilize, an optional Power-up Timer can be enabled to extend the Reset time after a BOR or POR event.

A simplified block diagram of the On-Chip Reset Circuit is shown in [Figure 6-1](#).

**FIGURE 6-1: SIMPLIFIED BLOCK DIAGRAM OF ON-CHIP RESET CIRCUIT**

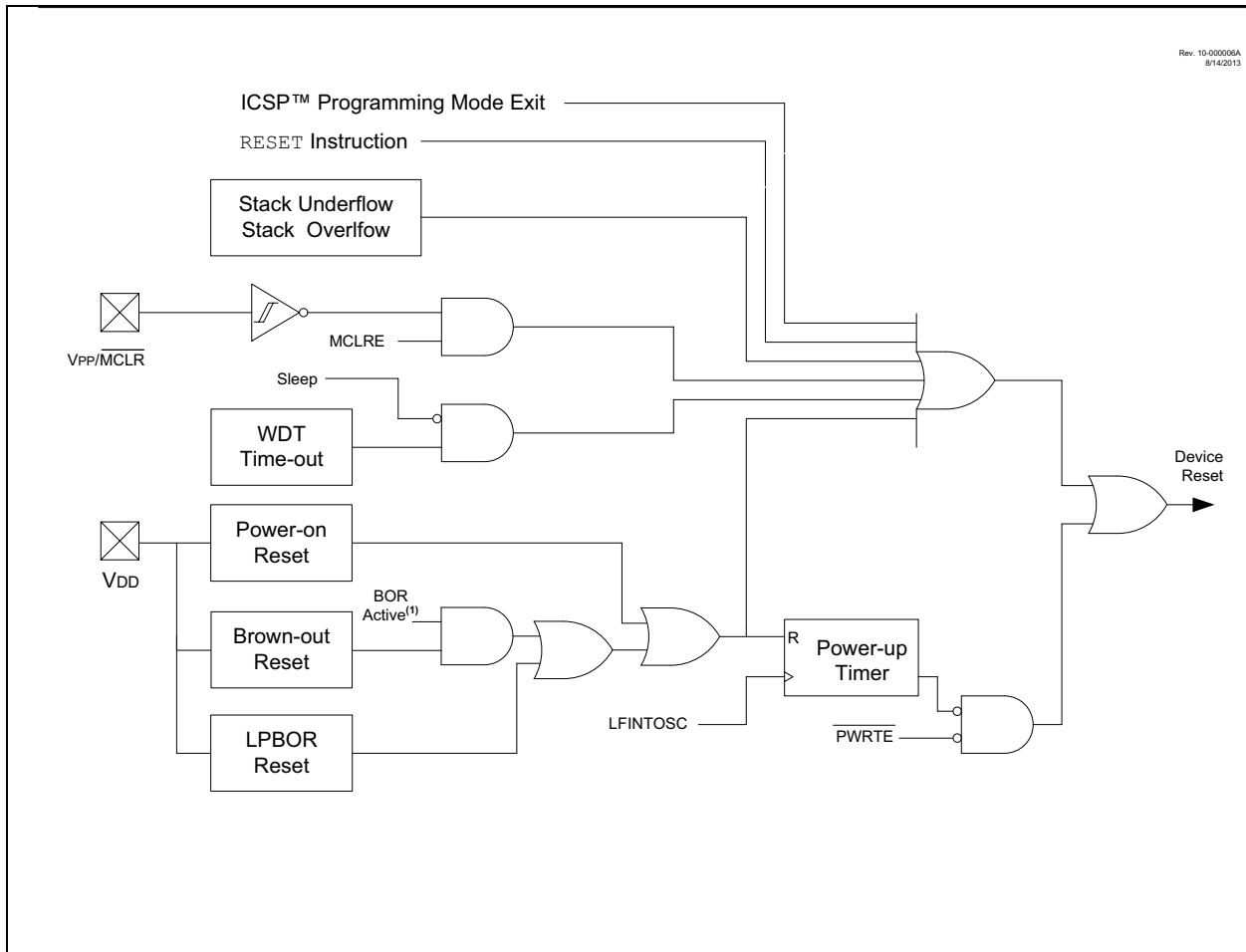

# PIC12(L)F1571/2

## 6.1 Power-on Reset (POR)

The POR circuit holds the device in Reset until VDD has reached an acceptable level for minimum operation. Slow rising VDD, fast operating speeds or analog performance may require greater than minimum VDD. The PWRT, BOR or MCLR features can be used to extend the start-up period until all device operation conditions have been met.

### 6.1.1 POWER-UP TIMER (PWRT)

The Power-up Timer provides a nominal 64 ms time-out on a POR or Brown-out Reset.

The device is held in Reset as long as PWRT is active. The PWRT delay allows additional time for the VDD to rise to an acceptable level. The Power-up Timer is enabled by clearing the PWRT $\overline{E}$  bit in the Configuration Words.

The Power-up Timer starts after the release of the POR and BOR.

For additional information, refer to Application Note AN607, "Power-up Trouble Shooting" (DS00000607).

## 6.2 Brown-out Reset (BOR)

The BOR circuit holds the device in Reset when VDD reaches a selectable minimum level. Between the POR and BOR, complete voltage range coverage for execution protection can be implemented.

The Brown-out Reset module has four operating modes controlled by the BOREN<1:0> bits in the Configuration Words. The four operating modes are:

- BOR is always on
- BOR is off when in Sleep
- BOR is controlled by software
- BOR is always off

Refer to [Table 6-1](#) for more information.

The Brown-out Reset voltage level is selectable by configuring the BORV bit in the Configuration Words.

A VDD noise rejection filter prevents the BOR from triggering on small events. If VDD falls below VBOR for a duration greater than parameter, TBORDC, the device will reset. See [Figure 6-2](#) for more information.

**TABLE 6-1: BOR OPERATING MODES**

BOREN<1:0>	SBOREN	Device Mode	BOR Mode	Instruction Execution upon: Release of POR or Wake-up from Sleep
11	X	X	Active	Waits for BOR ready <sup>(1)</sup> (BORRDY = 1)
10	X	Awake	Active	Waits for BOR ready (BORRDY = 1)
		Sleep	Disabled	
01	1	X	Active	Waits for BOR ready <sup>(1)</sup> (BORRDY = 1)
	0	X	Disabled	Begins immediately (BORRDY = x)
00	X	X	Disabled	

**Note 1:** In these specific cases, "release of POR" and "wake-up from Sleep", there is no delay in start-up. The BOR ready flag (BORRDY = 1) will be set before the CPU is ready to execute instructions because the BOR circuit is forced on by the BOREN<1:0> bits.

## 6.2.1 BOR IS ALWAYS ON

When the BOREN<sub>x</sub> bits of the Configuration Words are programmed to '11', the BOR is always on. The device start-up will be delayed until the BOR is ready and VDD is higher than the BOR threshold.

BOR protection is active during Sleep. The BOR does not delay wake-up from Sleep.

## 6.2.2 BOR IS OFF IN SLEEP

When the BOREN<sub>x</sub> bits of the Configuration Words are programmed to '10', the BOR is on, except in Sleep. The device start-up will be delayed until the BOR is ready and VDD is higher than the BOR threshold.

BOR protection is not active during Sleep. The device wake-up will be delayed until the BOR is ready.

## 6.2.3 BOR CONTROLLED BY SOFTWARE

When the BOREN<sub>x</sub> bits of the Configuration Words are programmed to '01', the BOR is controlled by the SBOREN bit of the BORCON register. The device start-up is not delayed by the BOR ready condition or the VDD level.

BOR protection begins as soon as the BOR circuit is ready. The status of the BOR circuit is reflected in the BORRDY bit of the BORCON register.

BOR protection is unchanged by Sleep.

**FIGURE 6-2: BROWN-OUT SITUATIONS**

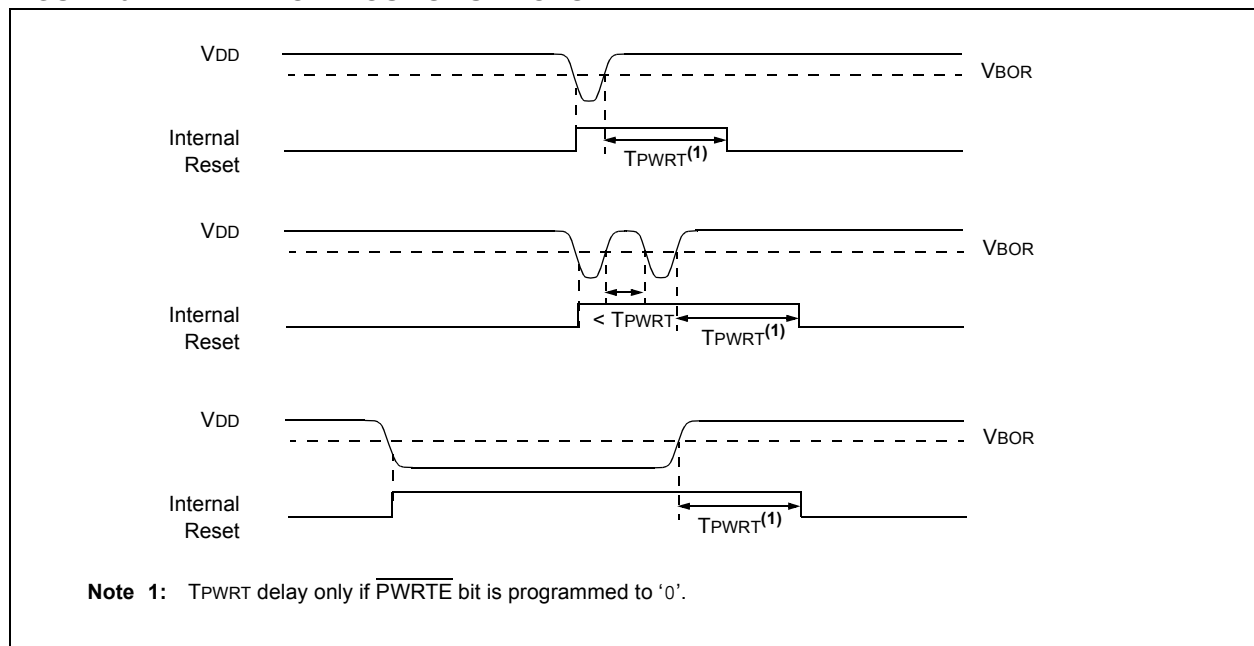

# PIC12(L)F1571/2

## 6.3 Register Definitions: BOR Control

### REGISTER 6-1: BORCON: BROWN-OUT RESET CONTROL REGISTER

R/W-1/u	R/W-0/u	U-0	U-0	U-0	U-0	U-0	R-q/u
SBOREN	BORFS <sup>(1)</sup>	—	—	—	—	—	BORRDY
bit 7							bit 0

#### Legend:

R = Readable bit	W = Writable bit	U = Unimplemented bit, read as '0'
u = Bit is unchanged	x = Bit is unknown	-n/n = Value at POR and BOR/Value at all other Resets
'1' = Bit is set	'0' = Bit is cleared	q = Value depends on condition

bit 7 **SBOREN:** Software Brown-out Reset Enable bit

If BOREN<1:0> in Configuration Words = 01:

1 = BOR is enabled

0 = BOR is disabled

If BOREN <1:0> in Configuration Words ≠ 01:

SBOREN is read/write, but has no effect on the BOR.

bit 6 **BORFS:** Brown-out Reset Fast Start bit<sup>(1)</sup>

If BOREN <1:0> = 10 (Disabled in Sleep) or BOREN<1:0> = 01 (Under software control):

1 = Band gap is forced on always (covers Sleep/wake-up/operating cases)

0 = Band gap operates normally and may turn off

If BOREN<1:0> = 11 (Always On) or BOREN<1:0> = 00 (Always Off):

BORFS is read/write, but has no effect on the BOR.

bit 5-1 **Unimplemented:** Read as '0'

bit 0 **BORRDY:** Brown-out Reset Circuit Ready Status bit

1 = The Brown-out Reset circuit is active

0 = The Brown-out Reset circuit is inactive

**Note 1:** BOREN<1:0> bits are located in the Configuration Words.

## 6.4 Low-Power Brown-out Reset (LPBOR)

The Low-Power Brown-out Reset (LPBOR) operates like the BOR to detect low-voltage conditions on the VDD pin. When too low of a voltage is detected, the device is held in Reset. When this occurs, a register bit (BOR) is changed to indicate that a BOR Reset has occurred. The BOR bit in PCON is used for both BOR and the LPBOR. Refer to [Register 6-2](#).

The LPBOR Voltage Threshold (VLPBOR) has a wider tolerance than the BOR (VBOR), but requires much less current (LPBOR current) to operate. The LPBOR is intended for use when the BOR is configured as disabled (BOREN<1:0> = 00) or disabled in Sleep mode (BOREN<1:0> = 10).

Refer to [Figure 6-1](#) to see how the LPBOR interacts with other modules.

### 6.4.1 ENABLING LPBOR

The LPBOR is controlled by the  $\overline{\text{LPBOR}}$  bit of the Configuration Words. When the device is erased, the LPBOR module defaults to disabled.

## 6.5 $\overline{\text{MCLR}}$

The  $\overline{\text{MCLR}}$  is an optional external input that can reset the device. The  $\overline{\text{MCLR}}$  function is controlled by the MCLRE and LVP bits of the Configuration Words ([Table 6-2](#)).

**TABLE 6-2:  $\overline{\text{MCLR}}$  CONFIGURATION**

MCLRE	LVP	$\overline{\text{MCLR}}$
0	0	Disabled
1	0	Enabled
x	1	Enabled

### 6.5.1 $\overline{\text{MCLR}}$ ENABLED

When  $\overline{\text{MCLR}}$  is enabled and the pin is held low, the device is held in Reset. The  $\overline{\text{MCLR}}$  pin is connected to VDD through an internal weak pull-up.

The device has a noise filter in the  $\overline{\text{MCLR}}$  Reset path. The filter will detect and ignore small pulses.

**Note:** A Reset does not drive the  $\overline{\text{MCLR}}$  pin low.

### 6.5.2 $\overline{\text{MCLR}}$ DISABLED

When  $\overline{\text{MCLR}}$  is disabled, the pin functions as a general purpose input and the internal weak pull-up is under software control. See [Section 11.3 “PORTA Registers”](#) for more information.

## 6.6 Watchdog Timer (WDT) Reset

The Watchdog Timer generates a Reset if the firmware does not issue a  $\overline{\text{CLRWDT}}$  instruction within the time-out period. The  $\overline{\text{TO}}$  and  $\overline{\text{PD}}$  bits in the STATUS register are changed to indicate the WDT Reset. See [Section 9.0 “Watchdog Timer \(WDT\)”](#) for more information.

## 6.7 RESET Instruction

A RESET instruction will cause a device Reset. The  $\overline{\text{RI}}$  bit in the PCON register will be set to '0'. See [Table 6-4](#) for default conditions after a RESET instruction has occurred.

## 6.8 Stack Overflow/Underflow Reset

The device can reset when the Stack overflows or underflows. The STKOVF or STKUNF bits of the PCON register indicate the Reset condition. These Resets are enabled by setting the STVREN bit in the Configuration Words. See [Section 3.5.2 “Overflow/Underflow Reset”](#) for more information.

## 6.9 Programming Mode Exit

Upon exit of Programming mode, the device will behave as if a POR had just occurred.

## 6.10 Power-up Timer

The Power-up Timer optionally delays device execution after a BOR or POR event. This timer is typically used to allow VDD to stabilize before allowing the device to start running.

The Power-up Timer is controlled by the  $\overline{\text{PWRTÉ}}$  bit of the Configuration Words.

## 6.11 Start-up Sequence

Upon the release of a POR or BOR, the following must occur before the device will begin executing:

1. Power-up Timer runs to completion (if enabled).
2.  $\overline{\text{MCLR}}$  must be released (if enabled).

The total time-out will vary based on oscillator configuration and Power-up Timer configuration. See [Section 5.0 “Oscillator Module”](#) for more information.

The Power-up Timer runs independently of a  $\overline{\text{MCLR}}$  Reset. If  $\overline{\text{MCLR}}$  is kept low long enough, the Power-up Timer will expire. Upon bringing  $\overline{\text{MCLR}}$  high, the device will begin execution after 10 Fosc cycles (see [Figure 6-3](#)). This is useful for testing purposes or to synchronize more than one device operating in parallel.

**FIGURE 6-3: RESET START-UP SEQUENCE**

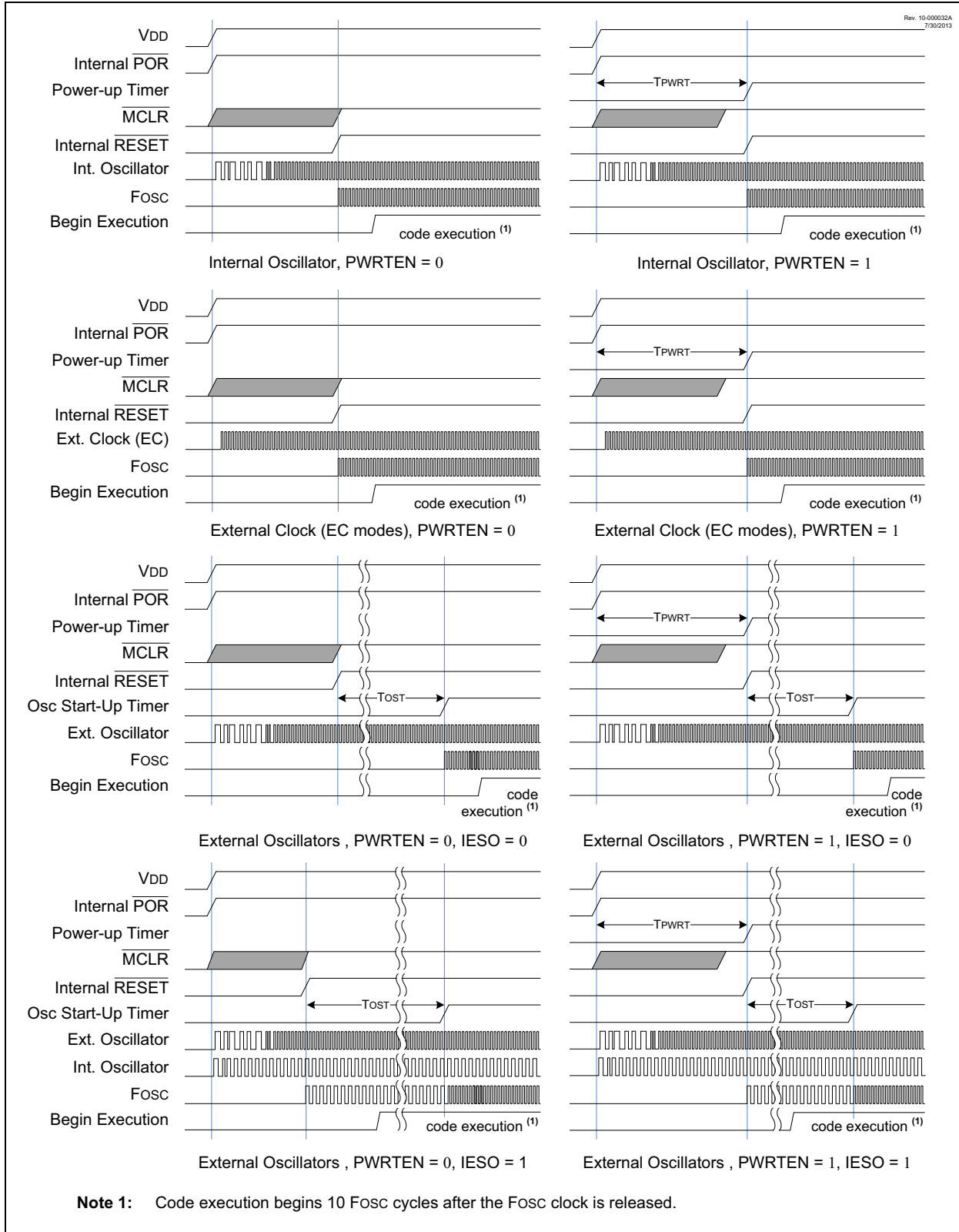



## 6.12 Determining the Cause of a Reset

Upon any Reset, multiple bits in the STATUS and PCON registers are updated to indicate the cause of the Reset. Table 6-3 and Table 6-4 show the Reset conditions of these registers.

**TABLE 6-3: RESET STATUS BITS AND THEIR SIGNIFICANCE**

STKOVF	STKUNF	RWD $\overline{T}$	RMCL $\overline{R}$	RI	POR	BOR	TO	PD	Condition
0	0	1	1	1	0	x	1	1	Power-on Reset
0	0	1	1	1	0	x	0	x	Illegal, $\overline{TO}$ is Set on $\overline{POR}$
0	0	1	1	1	0	x	x	0	Illegal, $\overline{PD}$ is Set on $\overline{POR}$
0	0	u	1	1	u	0	1	1	Brown-out Reset
u	u	0	u	u	u	u	0	u	WDT Reset
u	u	u	u	u	u	u	0	0	WDT Wake-up from Sleep
u	u	u	u	u	u	u	1	0	Interrupt Wake-up from Sleep
u	u	u	0	u	u	u	u	u	$\overline{MCLR}$ Reset during Normal Operation
u	u	u	0	u	u	u	1	0	$\overline{MCLR}$ Reset during Sleep
u	u	u	u	0	u	u	u	u	RESET Instruction Executed
1	u	u	u	u	u	u	u	u	Stack Overflow Reset (STVREN = 1)
u	1	u	u	u	u	u	u	u	Stack Underflow Reset (STVREN = 1)

**TABLE 6-4: RESET CONDITION FOR SPECIAL REGISTERS**

Condition	Program Counter	STATUS Register	PCON Register
Power-on Reset	0000h	---1 1000	00-- 110x
$\overline{MCLR}$ Reset during normal operation	0000h	---u uuuu	uu-- 0uuu
$\overline{MCLR}$ Reset during Sleep	0000h	---1 0uuu	uu-- 0uuu
WDT Reset	0000h	---0 uuuu	uu-- uuuu
WDT Wake-up from Sleep	PC + 1	---0 0uuu	uu-- uuuu
Brown-out Reset	0000h	---1 1uuu	00-- 11u0
Interrupt Wake-up from Sleep	PC + 1 <sup>(1)</sup>	---1 0uuu	uu-- uuuu
RESET Instruction Executed	0000h	---u uuuu	uu-- u0uu
Stack Overflow Reset (STVREN = 1)	0000h	---u uuuu	1u-- uuuu
Stack Underflow Reset (STVREN = 1)	0000h	---u uuuu	u1-- uuuu

**Legend:** u = unchanged; x = unknown; - = unimplemented bit, reads as '0'.

**Note 1:** When the wake-up is due to an interrupt and the Global Interrupt Enable bit (GIE) is set, the return address is pushed on the stack and the PC is loaded with the interrupt vector (0004h) after execution of PC + 1.

# PIC12(L)F1571/2

## 6.13 Power Control (PCON) Register

The Power Control (PCON) register contains flag bits to differentiate between a:

- Power-on Reset ( $\overline{\text{POR}}$ )
- Brown-out Reset ( $\overline{\text{BOR}}$ )
- $\overline{\text{RESET}}$  Instruction Reset ( $\overline{\text{RI}}$ )
- $\overline{\text{MCLR}}$  Reset ( $\overline{\text{RMCLR}}$ )
- Watchdog Timer Reset ( $\overline{\text{RWDT}}$ )
- Stack Underflow Reset (STKUNF)
- Stack Overflow Reset (STKOVF)

The PCON register bits are shown in [Register 6-2](#).

## 6.14 Register Definitions: Power Control

**REGISTER 6-2: PCON: POWER CONTROL REGISTER**

R/W/HS-0/q	R/W/HS-0/q	U-0	R/W/HC-1/q	R/W/HC-1/q	R/W/HC-1/q	R/W/HC-q/u	R/W/HC-q/u
STKOVF	STKUNF	—	$\overline{\text{RWDT}}$	$\overline{\text{RMCLR}}$	$\overline{\text{RI}}$	$\overline{\text{POR}}$	$\overline{\text{BOR}}$
bit 7							bit 0

<b>Legend:</b>	HC = Hardware Clearable bit	HS = Hardware Settable bit
R = Readable bit	W = Writable bit	U = Unimplemented bit, read as '0'
u = Bit is unchanged	x = Bit is unknown	-n/n = Value at POR and BOR/Value at all other Resets
'1' = Bit is set	'0' = Bit is cleared	q = Value depends on condition

bit 7	<b>STKOVF:</b> Stack Overflow Reset Flag bit 1 = A Stack Overflow Reset occurred 0 = A Stack Overflow Reset has not occurred or is cleared by firmware
bit 6	<b>STKUNF:</b> Stack Underflow Reset Flag bit 1 = A Stack Underflow Reset occurred 0 = A Stack Underflow Reset has not occurred or is cleared by firmware
bit 5	<b>Unimplemented:</b> Read as '0'
bit 4	<b><math>\overline{\text{RWDT}}</math>:</b> Watchdog Timer Reset Flag bit 1 = A Watchdog Timer Reset has not occurred or is set by firmware 0 = A Watchdog Timer Reset has occurred (cleared by hardware)
bit 3	<b><math>\overline{\text{RMCLR}}</math>:</b> $\overline{\text{MCLR}}$ Reset Flag bit 1 = A $\overline{\text{MCLR}}$ Reset has not occurred or is set by firmware 0 = A $\overline{\text{MCLR}}$ Reset has occurred (cleared by hardware)
bit 2	<b><math>\overline{\text{RI}}</math>:</b> $\overline{\text{RESET}}$ Instruction Flag bit 1 = A $\overline{\text{RESET}}$ instruction has not been executed or set by firmware 0 = A $\overline{\text{RESET}}$ instruction has been executed (cleared by hardware)
bit 1	<b><math>\overline{\text{POR}}</math>:</b> Power-on Reset Status bit 1 = No Power-on Reset occurred 0 = A Power-on Reset occurred (must be set in software after a Power-on Reset occurs)
bit 0	<b><math>\overline{\text{BOR}}</math>:</b> Brown-out Reset Status bit 1 = No Brown-out Reset occurred 0 = A Brown-out Reset occurred (must be set in software after a Power-on Reset or Brown-out Reset occurs)

**TABLE 6-5: SUMMARY OF REGISTERS ASSOCIATED WITH RESETS**

Name	Bit 7	Bit 6	Bit 5	Bit 4	Bit 3	Bit 2	Bit 1	Bit 0	Register on Page
BORCON	SBOREN	BORFS	—	—	—	—	—	BORRDY	62
PCON	STKOVF	STKUNF	—	RWD $\bar{T}$	RMCLR	RI	POR	BOR	66
STATUS	—	—	—	T $\bar{O}$	P $\bar{D}$	Z	DC	C	19
WDTCON	—	—	WDTPS<4:0>					SWDTEN	89

**Legend:** — = unimplemented bit, reads as '0'. Shaded cells are not used by Resets.

**Note 1:** Other (non Power-up) Resets include MCLR Reset and Watchdog Timer Reset during normal operation.

**TABLE 6-6: SUMMARY OF CONFIGURATION WORD WITH RESETS**

Name	Bits	Bit -/7	Bit -/6	Bit 13/5	Bit 12/4	Bit 11/3	Bit 10/2	Bit 9/1	Bit 8/0	Register on Page
CONFIG1	13:8	—	—	—	—	CLKOUTEN	BOREN<1:0>		—	42
	7:0	C $\bar{P}$	MCLRE	PWRTE	WDTE<1:0>		—	FOSC<1:0>		
CONFIG2	13:8	—	—	LVP	DEB $\bar{U}G$	LPBOR	BORV	STVREN	PLLEN	43
	7:0	—	—	—	—	—	WRT<1:0>			

**Legend:** — = unimplemented location, read as '0'. Shaded cells are not used by Resets.

# PIC12(L)F1571/2

---

NOTES:

## 7.0 INTERRUPTS

The interrupt feature allows certain events to preempt normal program flow. Firmware is used to determine the source of the interrupt and act accordingly. Some interrupts can be configured to wake the MCU from Sleep mode.

This chapter contains the following information for interrupts:

- Operation
- Interrupt Latency
- Interrupts during Sleep
- INT Pin
- Automatic Context Saving

Many peripherals produce interrupts. Refer to the corresponding chapters for details.

A block diagram of the interrupt logic is shown in [Figure 7-1](#).

**FIGURE 7-1: INTERRUPT LOGIC**

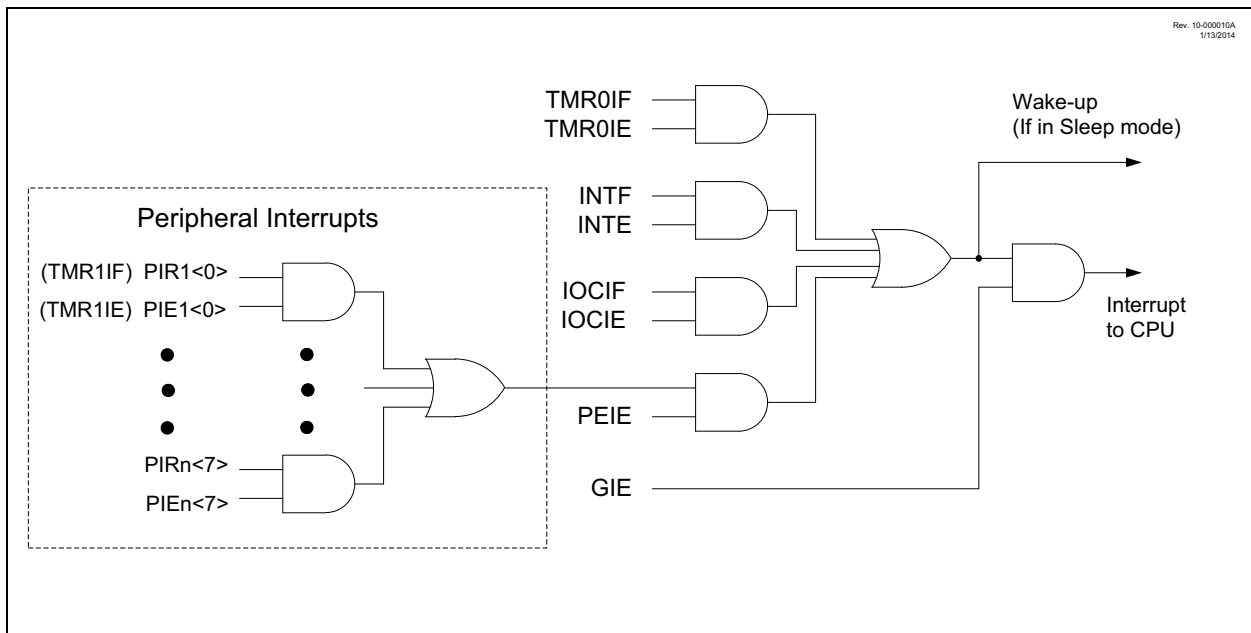

# PIC12(L)F1571/2

---

## 7.1 Operation

Interrupts are disabled upon any device Reset. They are enabled by setting the following bits:

- GIE bit of the INTCON register
- Interrupt enable bit(s) for the specific interrupt event(s)
- PEIE bit of the INTCON register (if the interrupt enable bit of the interrupt event is contained in the PIE1, PIE2 and PIE3 registers)

The INTCON, PIR1, PIR2 and PIR3 registers record individual interrupts via interrupt flag bits. Interrupt flag bits will be set, regardless of the status of the GIE, PEIE and individual interrupt enable bits.

The following events happen when an interrupt event occurs while the GIE bit is set:

- Current prefetched instruction is flushed
- GIE bit is cleared
- Current Program Counter (PC) is pushed onto the stack
- Critical registers are automatically saved to the shadow registers (See “[Section 7.5 “Automatic Context Saving”](#).”)
- PC is loaded with the interrupt vector, 0004h

The firmware within the Interrupt Service Routine (ISR) should determine the source of the interrupt by polling the interrupt flag bits. The interrupt flag bits must be cleared before exiting the ISR to avoid repeated interrupts. Because the GIE bit is cleared, any interrupt that occurs while executing the ISR will be recorded through its interrupt flag, but will not cause the processor to redirect to the interrupt vector.

The `RETFIE` instruction exits the ISR by popping the previous address from the stack, restoring the saved context from the shadow registers and setting the GIE bit.

For additional information on a specific interrupt's operation, refer to its peripheral chapter.

- |  |
|--|
| <p><b>Note 1:</b> Individual interrupt flag bits are set, regardless of the state of any other enable bits.</p> <p><b>2:</b> All interrupts will be ignored while the GIE bit is cleared. Any interrupt occurring while the GIE bit is clear will be serviced when the GIE bit is set again.</p> |
|--|

## 7.2 Interrupt Latency

Interrupt latency is defined as the time from when the interrupt event occurs to the time code execution at the interrupt vector begins. The latency for synchronous interrupts is three or four instruction cycles. For asynchronous interrupts, the latency is three to five instruction cycles, depending on when the interrupt occurs. See [Figure 7-2](#) and [Figure 7-3](#) for more details.

**FIGURE 7-2: INTERRUPT LATENCY**

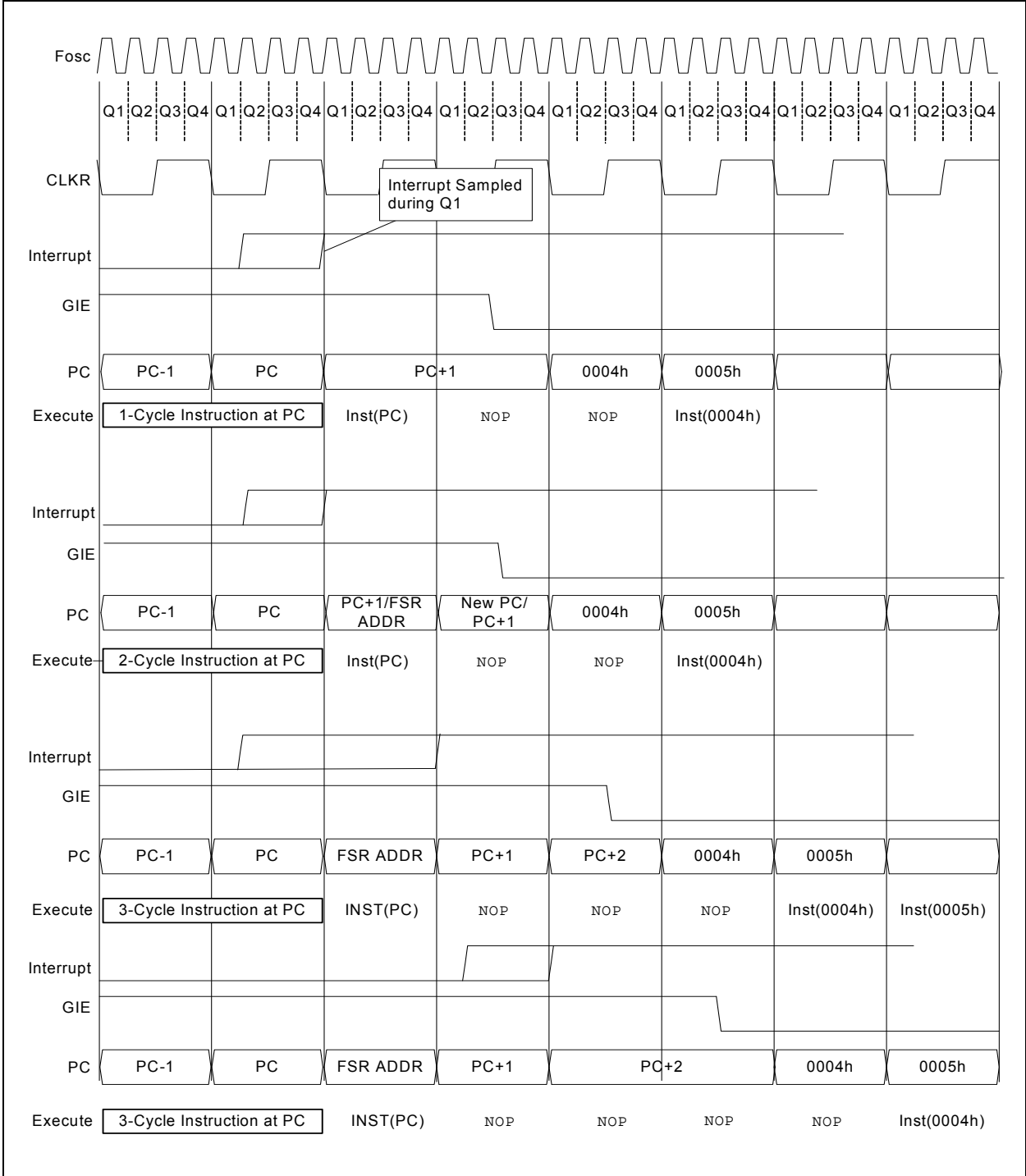

# PIC12(L)F1571/2

**FIGURE 7-3: INT PIN INTERRUPT TIMING**

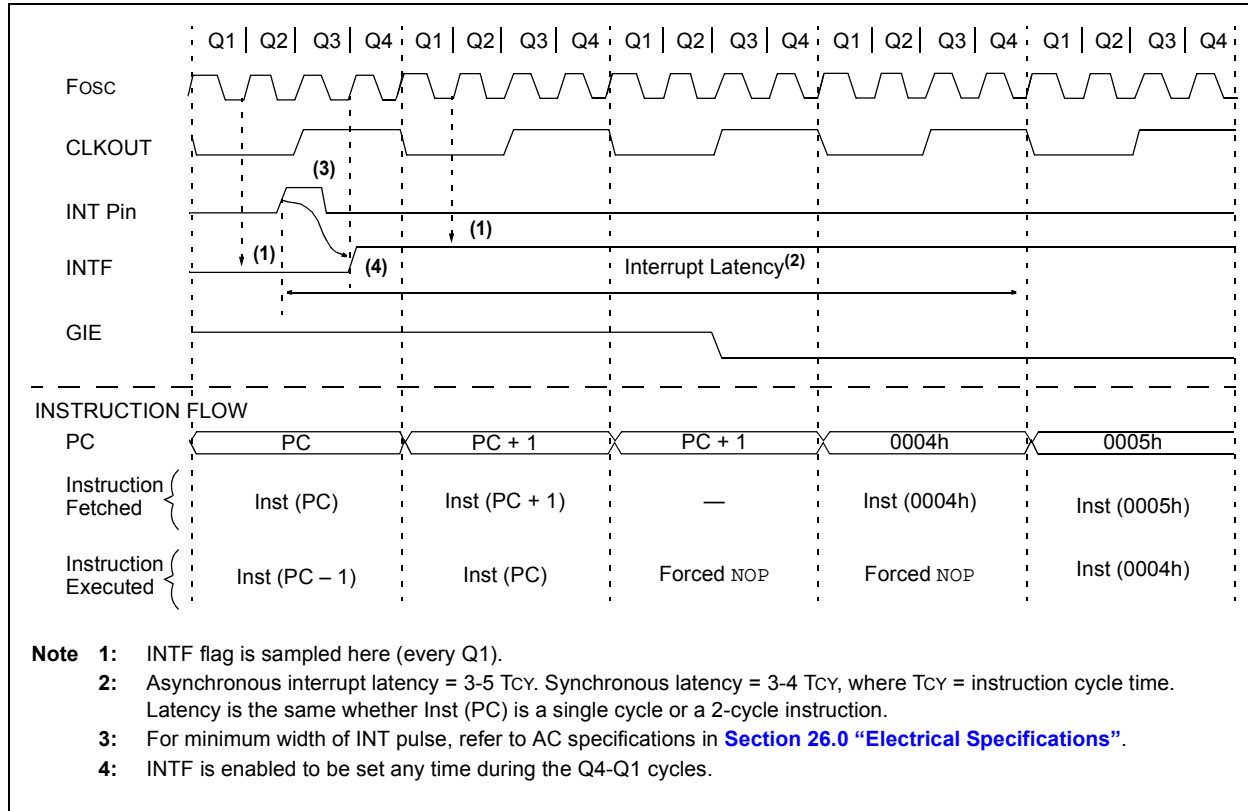



## 7.3 Interrupts During Sleep

Some interrupts can be used to wake from Sleep. To wake from Sleep, the peripheral must be able to operate without the system clock. The interrupt source must have the appropriate Interrupt Enable bit(s) set prior to entering Sleep.

On waking from Sleep, if the GIE bit is also set, the processor will branch to the interrupt vector. Otherwise, the processor will continue executing instructions after the `SLEEP` instruction. The instruction directly after the `SLEEP` instruction will always be executed before branching to the ISR. Refer to [Section 8.0 “Power-Down Mode \(Sleep\)”](#) for more details.

## 7.4 INT Pin

The INT pin can be used to generate an asynchronous edge-triggered interrupt. This interrupt is enabled by setting the INTE bit of the INTCON register. The INTEDG bit of the OPTION\_REG register determines on which edge the interrupt will occur. When the INTEDG bit is set, the rising edge will cause the interrupt. When the INTEDG bit is clear, the falling edge will cause the interrupt. The INTF bit of the INTCON register will be set when a valid edge appears on the INT pin. If the GIE and INTE bits are also set, the processor will redirect program execution to the interrupt vector.

## 7.5 Automatic Context Saving

Upon entering an interrupt, the return PC address is saved on the stack. Additionally, the following registers are automatically saved in the shadow registers:

- W register
- STATUS register (except for  $\overline{TO}$  and  $\overline{PD}$ )
- BSR register
- FSR registers
- PCLATH register

Upon exiting the Interrupt Service Routine, these registers are automatically restored. Any modifications to these registers during the ISR will be lost. If modifications to any of these registers are desired, the corresponding shadow register should be modified and the value will be restored when exiting the ISR. The shadow registers are available in Bank 31 and are readable and writable. Depending on the user's application, other registers may also need to be saved.

# PIC12(L)F1571/2

## 7.6 Register Definitions: Interrupt Control

### REGISTER 7-1: INTCON: INTERRUPT CONTROL REGISTER

R/W-0/0	R/W-0/0	R/W-0/0	R/W-0/0	R/W-0/0	R/W-0/0	R/W-0/0	R-0/0
GIE <sup>(1)</sup>	PEIE <sup>(2)</sup>	TMR0IE	INTE	IOCFIE	TMR0IF	INTF	IOCFIF <sup>(3)</sup>
bit 7							bit 0

#### Legend:

R = Readable bit	W = Writable bit	
u = Bit is unchanged	x = Bit is unknown	U = Unimplemented bit, read as '0'
'1' = Bit is set	'0' = Bit is cleared	-n/n = Value at POR and BOR/Value at all other Resets

- bit 7      **GIE:** Global Interrupt Enable bit<sup>(1)</sup>  
 1 = Enables all active interrupts  
 0 = Disables all interrupts
- bit 6      **PEIE:** Peripheral Interrupt Enable bit<sup>(2)</sup>  
 1 = Enables all active peripheral interrupts  
 0 = Disables all peripheral interrupts
- bit 5      **TMROIE:** Timer0 Overflow Interrupt Enable bit  
 1 = Enables the Timer0 interrupt  
 0 = Disables the Timer0 interrupt
- bit 4      **INTE:** INT External Interrupt Enable bit  
 1 = Enables the INT external interrupt  
 0 = Disables the INT external interrupt
- bit 3      **IOCFIE:** Interrupt-On-Change Enable bit  
 1 = Enables the Interrupt-On-Change  
 0 = Disables the Interrupt-On-Change
- bit 2      **TMR0IF:** Timer0 Overflow Interrupt Flag bit  
 1 = TMR0 register has overflowed  
 0 = TMR0 register has not overflow
- bit 1      **INTF:** INT External Interrupt Flag bit  
 1 = The INT external interrupt occurred  
 0 = The INT external interrupt did not occur
- bit 0      **IOCFIF:** Interrupt-On-Change Interrupt Flag bit<sup>(3)</sup>  
 1 = When at least one of the Interrupt-On-Change pins changed state  
 0 = None of the Interrupt-On-Change pins have changed state

**Note 1:** Interrupt flag bits are set when an interrupt condition occurs, regardless of the state of its corresponding enable bit or the Global Interrupt Enable bit, GIE, of the INTCON register. User software should ensure the appropriate interrupt flag bits are clear prior to enabling an interrupt.

**2:** Bit PEIE of the INTCON register must be set to enable any peripheral interrupt.

**3:** The IOCFIF Flag bit is read-only and cleared when all the Interrupt-On-Change flags in the IOCxF registers have been cleared by software.

## REGISTER 7-2: PIE1: PERIPHERAL INTERRUPT ENABLE REGISTER 1

R/W-0/0	R/W-0/0	R/W-0/0	R/W-0/0	U-0	U-0	R/W-0/0	R/W-0/0
TMR1GIE	ADIE	RCIE <sup>(1)</sup>	TXIE <sup>(1)</sup>	—	—	TMR2IE	TMR1IE
bit 7							bit 0

### Legend:

R = Readable bit

W = Writable bit

u = Bit is unchanged

x = Bit is unknown

U = Unimplemented bit, read as '0'

'1' = Bit is set

'0' = Bit is cleared

-n/n = Value at POR and BOR/Value at all other Resets

- bit 7      **TMR1GIE:** Timer1 Gate Interrupt Enable bit  
 1 = Enables the Timer1 gate acquisition interrupt  
 0 = Disables the Timer1 gate acquisition interrupt
- bit 6      **ADIE:** Analog-to-Digital Converter (ADC) Interrupt Enable bit  
 1 = Enables the ADC interrupt  
 0 = Disables the ADC interrupt
- bit 5      **RCIE:** USART Receive Interrupt Enable bit<sup>(1)</sup>  
 1 = Enables the USART receive interrupt  
 0 = Disables the USART receive interrupt
- bit 4      **TXIE:** USART Transmit Interrupt Enable bit<sup>(1)</sup>  
 1 = Enables the USART transmit interrupt  
 0 = Disables the USART transmit interrupt
- bit 3-2    **Unimplemented:** Read as '0'
- bit 1      **TMR2IE:** TMR2 to PR2 Match Interrupt Enable bit  
 1 = Enables the Timer2 to PR2 match interrupt  
 0 = Disables the Timer2 to PR2 match interrupt
- bit 0      **TMR1IE:** Timer1 Overflow Interrupt Enable bit  
 1 = Enables the Timer1 overflow interrupt  
 0 = Disables the Timer1 overflow interrupt

**Note 1:** PIC12(L)F1572 only.

**2:** Bit PEIE of the INTCON register must be set to enable any peripheral interrupt.

**Note:** Bit PEIE of the INTCON register must be set to enable any peripheral interrupt.

# PIC12(L)F1571/2

## REGISTER 7-3: PIE2: PERIPHERAL INTERRUPT ENABLE REGISTER 2

U-0	U-0	R/W-0/0	U-0	U-0	U-0	U-0	U-0
—	—	C1IE	—	—	—	—	—
bit 7							bit 0

### Legend:

R = Readable bit

W = Writable bit

u = Bit is unchanged

x = Bit is unknown

U = Unimplemented bit, read as '0'

'1' = Bit is set

'0' = Bit is cleared

-n/n = Value at POR and BOR/Value at all other Resets

bit 7-6 **Unimplemented:** Read as '0'

bit 5 **C1IE:** Comparator C1 Interrupt Enable bit

1 = Enables the Comparator C1 interrupt

0 = Disables the Comparator C1 interrupt

bit 4-0 **Unimplemented:** Read as '0'

**Note:** Bit PEIE of the INTCON register must be set to enable any peripheral interrupt.

## REGISTER 7-4: PIE3: PERIPHERAL INTERRUPT ENABLE REGISTER 3

U-0	R/W-0/0	R/W-0/0	R/W-0/0	U-0	U-0	U-0	U-0
—	PWM3IE	PWM2IE	PWM1IE	—	—	—	—
bit 7							bit 0

### Legend:

R = Readable bit

W = Writable bit

u = Bit is unchanged

x = Bit is unknown

U = Unimplemented bit, read as '0'

'1' = Bit is set

'0' = Bit is cleared

-n/n = Value at POR and BOR/Value at all other Resets

- bit 7        **Unimplemented:** Read as '0'
- bit 6        **PWM3IE:** PWM3 Interrupt Enable bit
  - 1 = Enables the PWM3 interrupt
  - 0 = Disables the PWM3 interrupt
- bit 5        **PWM2IE:** PWM2 Interrupt Enable bit
  - 1 = Enables the PWM2 interrupt
  - 0 = Disables the PWM2 interrupt
- bit 4        **PWM1IE:** PWM1 Interrupt Enable bit
  - 1 = Enables the PWM1 interrupt
  - 0 = Disables the PWM1 interrupt
- bit 3-0      **Unimplemented:** Read as '0'

**Note:** Bit PEIE of the INTCON register must be set to enable any peripheral interrupt.

# PIC12(L)F1571/2

## REGISTER 7-5: PIR1: PERIPHERAL INTERRUPT REQUEST REGISTER 1

R/W-0/0	R/W-0/0	R-0/0	R/W-0/0	U-0	U-0	R/W-0/0	R/W-0/0
TMR1GIF	ADIF	RCIF <sup>(1)</sup>	TXIF <sup>(1)</sup>	—	—	TMR2IF	TMR1IF
bit 7							bit 0

### Legend:

R = Readable bit

W = Writable bit

u = Bit is unchanged

x = Bit is unknown

U = Unimplemented bit, read as '0'

'1' = Bit is set

'0' = Bit is cleared

-n/n = Value at POR and BOR/Value at all other Resets

- bit 7      **TMR1GIF:** Timer1 Gate Interrupt Flag bit  
            1 = Interrupt is pending  
            0 = Interrupt is not pending
- bit 6      **ADIF:** ADC Interrupt Flag bit  
            1 = Interrupt is pending  
            0 = Interrupt is not pending
- bit 5      **RCIF:** USART Receive Interrupt Flag bit<sup>(1)</sup>  
            1 = Interrupt is pending  
            0 = Interrupt is not pending
- bit 4      **TXIF:** USART Transmit Interrupt Flag bit<sup>(1)</sup>  
            1 = Interrupt is pending  
            0 = Interrupt is not pending
- bit 3-2    **Unimplemented:** Read as '0'
- bit 1      **TMR2IF:** Timer2 to PR2 Interrupt Flag bit  
            1 = Interrupt is pending  
            0 = Interrupt is not pending
- bit 0      **TMR1IF:** Timer1 Overflow Interrupt Flag bit  
            1 = Interrupt is pending  
            0 = Interrupt is not pending

**Note 1:** PIC12(L)F1572 only.

**Note:** Interrupt flag bits are set when an interrupt condition occurs, regardless of the state of its corresponding enable bit or the Global Interrupt Enable bit, GIE, of the INTCON register. User software should ensure the appropriate interrupt flag bits are clear prior to enabling an interrupt.

## REGISTER 7-6: PIR2: PERIPHERAL INTERRUPT REQUEST REGISTER 2

U-0	U-0	R/W-0/0	U-0	U-0	U-0	U-0	U-0
—	—	C1IF	—	—	—	—	—
bit 7							bit 0

### Legend:

R = Readable bit

W = Writable bit

u = Bit is unchanged

x = Bit is unknown

U = Unimplemented bit, read as '0'

'1' = Bit is set

'0' = Bit is cleared

-n/n = Value at POR and BOR/Value at all other Resets

bit 7-6      **Unimplemented:** Read as '0'

bit 5      **C1IF:** Numerically Controlled Oscillator Flag bit

1 = Interrupt is pending

0 = Interrupt is not pending

bit 4-0      **Unimplemented:** Read as '0'

**Note:** Interrupt flag bits are set when an interrupt condition occurs, regardless of the state of its corresponding enable bit or the Global Interrupt Enable bit, GIE, of the INTCON register. User software should ensure the appropriate interrupt flag bits are clear prior to enabling an interrupt.

# PIC12(L)F1571/2

## REGISTER 7-7: PIR3: PERIPHERAL INTERRUPT REQUEST REGISTER 3

U-0	R-0/0	R-0/0	R-0/0	U-0	U-0	U-0	U-0
—	PWM3IF <sup>(1)</sup>	PWM2IF <sup>(1)</sup>	PWM1IF <sup>(1)</sup>	—	—	—	—
bit 7							bit 0

### Legend:

R = Readable bit

W = Writable bit

u = Bit is unchanged

x = Bit is unknown

U = Unimplemented bit, read as '0'

'1' = Bit is set

'0' = Bit is cleared

-n/n = Value at POR and BOR/Value at all other Resets

bit 7 **Unimplemented:** Read as '0'

bit 6 **PWM3IF:** PWM3 Interrupt Flag bit<sup>(1)</sup>

1 = Interrupt is pending

0 = Interrupt is not pending

bit 5 **PWM2IF:** PWM2 Interrupt Flag bit<sup>(1)</sup>

1 = Interrupt is pending

0 = Interrupt is not pending

bit 4 **PWM1IF:** PWM1 Interrupt Flag bit<sup>(1)</sup>

1 = Interrupt is pending

0 = Interrupt is not pending

bit 3-0 **Unimplemented:** Read as '0'

**Note 1:** These bits are read-only. They must be cleared by addressing the Flag registers inside the module.

**Note 2:** Interrupt flag bits are set when an interrupt condition occurs, regardless of the state of its corresponding enable bit or the Global Enable bit, GIE, of the INTCON register. User software should ensure the appropriate interrupt flag bits are clear prior to enabling an interrupt.



**TABLE 7-1: SUMMARY OF REGISTERS ASSOCIATED WITH INTERRUPTS**

Name	Bit 7	Bit 6	Bit 5	Bit 4	Bit 3	Bit 2	Bit 1	Bit 0	Register on Page
INTCON	GIE	PEIE	TMR0IE	INTE	IOCIE	TMR0IF	INTF	IOCIF	74
OPTION_REG	$\overline{\text{WPUEN}}$	INTEDG	TMR0CS	TMR0SE	PSA	PS<2:0>			157
PIE1	TMR1GIE	ADIE	RCIE <sup>(1)</sup>	TXIE <sup>(1)</sup>	—	—	TMR2IE	TMR1IE	75
PIE2	—	—	C1IE	—	—	—	—	—	76
PIE3	—	PWM3IE	PWM2IE	PWM1IE	—	—	—	—	77
PIR1	TMR1GIF	ADIF	RCIF <sup>(1)</sup>	TXIF <sup>(1)</sup>	—	—	TMR2IF	TMR1IF	78
PIR2	—	—	C1IF	—	—	—	—	—	79
PIR3	—	PWM3IF	PWM2IF	PWM1IF	—	—	—	—	80

**Legend:** — = unimplemented location, read as '0'. Shaded cells are not used by interrupts.

**Note 1:** PIC12(L)F1572 only.

# PIC12(L)F1571/2

---

NOTES:

## 8.0 POWER-DOWN MODE (SLEEP)

The Power-Down mode is entered by executing a `SLEEP` instruction.

Upon entering Sleep mode, the following conditions exist:

1. WDT will be cleared but keeps running if enabled for operation during Sleep.
2.  $\overline{PD}$  bit of the STATUS register is cleared.
3.  $\overline{TO}$  bit of the STATUS register is set.
4. CPU clock is disabled.
5. 31 kHz LFINTOSC is unaffected and peripherals that operate from it may continue operation in Sleep.
6. Timer1 and peripherals that operate from Timer1 continue operation in Sleep when the Timer1 clock source selected is:
  - LFINTOSC
  - T1CKI
  - Timer1 oscillator
7. ADC is unaffected if the dedicated FRC oscillator is selected.
8. I/O ports maintain the status they had before `SLEEP` was executed (driving high, low or high-impedance).
9. Resets other than WDT are not affected by Sleep mode.

Refer to individual chapters for more details on peripheral operation during Sleep.

To minimize current consumption, the following conditions should be considered:

- I/O pins should not be floating
- External circuitry sinking current from I/O pins
- Internal circuitry sourcing current from I/O pins
- Current draw from pins with internal weak pull-ups
- Modules using 31 kHz LFINTOSC
- CWG module using HFINTOSC

I/O pins that are high-impedance inputs should be pulled to  $V_{DD}$  or  $V_{SS}$  externally to avoid switching currents caused by floating inputs.

Examples of internal circuitry that might be sourcing current include the FVR module. See [Section 13.0 “Fixed Voltage Reference \(FVR\)”](#) for more information on this module.

### 8.1 Wake-up from Sleep

The device can wake-up from Sleep through one of the following events:

1. External Reset input on  $\overline{MCLR}$  pin if enabled.
2. BOR Reset if enabled.
3. POR Reset.
4. Watchdog Timer if enabled.
5. Any external interrupt.
6. Interrupts by peripherals capable of running during Sleep (see individual peripheral for more information)

The first three events will cause a device Reset. The last three events are considered a continuation of program execution. To determine whether a device Reset or wake-up event occurred, refer to [Section 6.12 “Determining the Cause of a Reset”](#).

When the `SLEEP` instruction is being executed, the next instruction ( $PC + 1$ ) is prefetched. For the device to wake-up through an interrupt event, the corresponding interrupt enable bit must be enabled. Wake-up will occur regardless of the state of the GIE bit. If the GIE bit is disabled, the device continues execution at the instruction after the `SLEEP` instruction. If the GIE bit is enabled, the device executes the instruction after the `SLEEP` instruction, the device will then call the Interrupt Service Routine. In cases where the execution of the instruction following `SLEEP` is not desirable, the user should have a `NOP` after the `SLEEP` instruction.

The WDT is cleared when the device wakes up from Sleep, regardless of the source of wake-up.

#### 8.1.1 WAKE-UP USING INTERRUPTS

When global interrupts are disabled (GIE cleared) and any interrupt source has both its interrupt enable bit and interrupt flag bit set, one of the following will occur:

- If the interrupt occurs **before** the execution of a `SLEEP` instruction:
  - `SLEEP` instruction will execute as a `NOP`.
  - WDT and WDT prescaler will not be cleared
  - $\overline{TO}$  bit of the STATUS register will not be set
  - $\overline{PD}$  bit of the STATUS register will not be cleared.
- If the interrupt occurs **during or after** the execution of a `SLEEP` instruction:
  - `SLEEP` instruction will be completely executed
  - Device will immediately wake-up from Sleep
  - WDT and WDT prescaler will be cleared
  - $\overline{TO}$  bit of the STATUS register will be set
  - $\overline{PD}$  bit of the STATUS register will be cleared

Even if the flag bits were checked before executing a `SLEEP` instruction, it may be possible for flag bits to become set before the `SLEEP` instruction completes. To determine whether a `SLEEP` instruction executed, test the  $\overline{PD}$  bit. If the  $\overline{PD}$  bit is set, the `SLEEP` instruction was executed as a `NOP`.

# PIC12(L)F1571/2

**FIGURE 8-1: WAKE-UP FROM SLEEP THROUGH INTERRUPT**

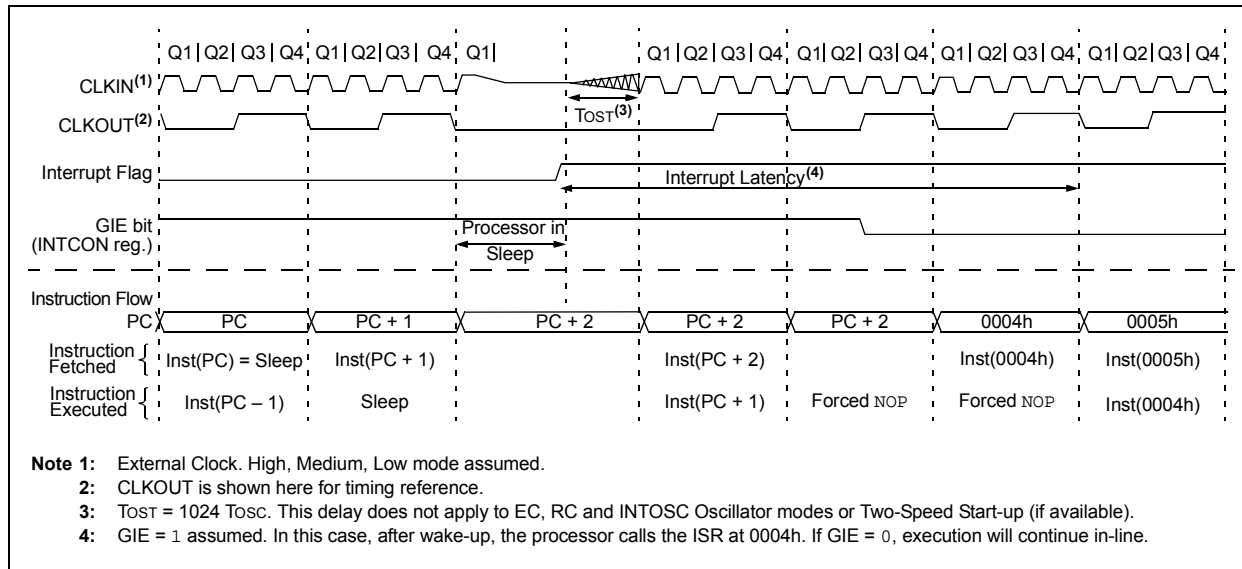

## 8.2 Low-Power Sleep Mode

This device contains an internal Low Dropout (LDO) voltage regulator, which allows the device I/O pins to operate at voltages up to 5.5V while the internal device logic operates at a lower voltage. The LDO and its associated reference circuitry must remain active when the device is in Sleep mode.

Low-Power Sleep mode allows the user to optimize the operating current in Sleep. Low-Power Sleep mode can be selected by setting the VREGPM bit of the VREGCON register, which puts the LDO and reference circuitry in a low-power state whenever the device is in Sleep.

### 8.2.1 SLEEP CURRENT VS. WAKE-UP TIME

In the default operating mode, the LDO and reference circuitry remain in the normal configuration while in Sleep. The device is able to exit Sleep mode quickly since all circuits remain active. In Low-Power Sleep mode, when waking up from Sleep, an extra delay time is required for these circuits to return to the normal configuration and stabilize.

The Low-Power Sleep mode is beneficial for applications that stay in Sleep mode for long periods of time. The normal mode is beneficial for applications that need to wake from Sleep quickly and frequently.

### 8.2.2 PERIPHERAL USAGE IN SLEEP

Some peripherals that can operate in Sleep mode will not operate properly with the Low-Power Sleep mode selected. The LDO will remain in the normal power mode when those peripherals are enabled. The Low-Power Sleep mode is intended for use with these peripherals:

- Brown-out Reset (BOR)
- Watchdog Timer (WDT)
- External interrupt pin/Interrupt-On-Change pins
- Timer1 (with external clock source)

The Complementary Waveform Generator (CWG) module can utilize the HFINTOSC oscillator as either a clock source or as an input source. Under certain conditions, when the HFINTOSC is selected for use with the CWG module, the HFINTOSC will remain active during Sleep. This will have a direct effect on the Sleep mode current.

Please refer to section [Section 23.10 “Operation During Sleep”](#) for more information.

**Note:** The PIC12LF1571/2 does not have a configurable Low-Power Sleep mode. PIC12LF1571/2 is an unregulated device and is always in the lowest power state when in Sleep with no wake-up time penalty. This device has a lower maximum  $V_{DD}$  and I/O voltage than the PIC12F1571/2. See [Section 26.0 “Electrical Specifications”](#) for more information.

## 8.3 Register Definitions: Voltage Regulator Control

### REGISTER 8-1: VREGCON: VOLTAGE REGULATOR CONTROL REGISTER<sup>(1)</sup>

U-0	U-0	U-0	U-0	U-0	U-0	R/W-0/0	R/W-1/1
—	—	—	—	—	—	VREGPM	Reserved
bit 7							bit 0

#### Legend:

R = Readable bit	W = Writable bit	
u = Bit is unchanged	x = Bit is unknown	U = Unimplemented bit, read as '0'
'1' = Bit is set	'0' = Bit is cleared	-n/n = Value at POR and BOR/Value at all other Resets

bit 7-2 **Unimplemented:** Read as '0'

bit 1 **VREGPM:** Voltage Regulator Power Mode Selection bit

1 = Low-Power Sleep mode enabled in Sleep<sup>(2)</sup>  
Draws lowest current in Sleep, slower wake-up.

0 = Normal power mode enabled in Sleep<sup>(2)</sup>  
Draws higher current in Sleep, faster wake-up.

bit 0 **Reserved:** Read as '1', maintain this bit set

**Note 1:** PIC12F1571/2 only.

**2:** See [Section 26.0 "Electrical Specifications"](#)

**TABLE 8-1: SUMMARY OF REGISTERS ASSOCIATED WITH POWER-DOWN MODE**

Name	Bit 7	Bit 6	Bit 5	Bit 4	Bit 3	Bit 2	Bit 1	Bit 0	Register on Page
INTCON	GIE	PEIE	TMR0IE	INTE	IOCFIE	TMR0IF	INTF	IOCFIF	74
IOCAF	—	—	IOCAF5	IOCAF4	IOCAF3	IOCAF2	IOCAF1	IOCAF0	122
IOCAN	—	—	IOCAN5	IOCAN4	IOCAN3	IOCAN2	IOCAN1	IOCAN0	121
IOCAP	—	—	IOCAP5	IOCAP4	IOCAP3	IOCAP2	IOCAP1	IOCAP0	121
PIE1	TMR1GIE	ADIE	RCIE <sup>(1)</sup>	TXIE <sup>(1)</sup>	—	—	TMR2IE	TMR1IE	75
PIE2	—	—	C1IE	—	—	—	—	—	76
PIE3	—	PWM3IE	PWM2IE	PWM1IE	—	—	—	—	77
PIR1	TMR1GIF	ADIF	RCIF <sup>(1)</sup>	TXIF <sup>(1)</sup>	—	—	TMR2IF	TMR1IF	78
PIR2	—	—	C1IF	—	—	—	—	—	79
PIR3	—	PWM3IF	PWM2IF	PWM1IF	—	—	—	—	80
STATUS	—	—	—	$\overline{TO}$	$\overline{PD}$	Z	DC	C	19
WDTCON	—	—	WDTPS<4:0>					SWDTEN	89

**Legend:** — = unimplemented, read as '0'. Shaded cells are not used in Power-Down mode.

**Note 1:** PIC12(L)F1572 only.

# PIC12(L)F1571/2

---

NOTES:

## 9.0 WATCHDOG TIMER (WDT)

The Watchdog Timer is a system timer that generates a Reset if the firmware does not issue a `CLRWDT` instruction within the time-out period. The Watchdog Timer is typically used to recover the system from unexpected events.

The WDT has the following features:

- Independent clock source
- Multiple operating modes:
  - WDT is always on
  - WDT is off when in Sleep
  - WDT is controlled by software
  - WDT is always off
- Configurable time-out period is from 1 ms to 256 seconds (nominal)
- Multiple Reset conditions
- Operation during Sleep

**FIGURE 9-1: WATCHDOG TIMER BLOCK DIAGRAM**

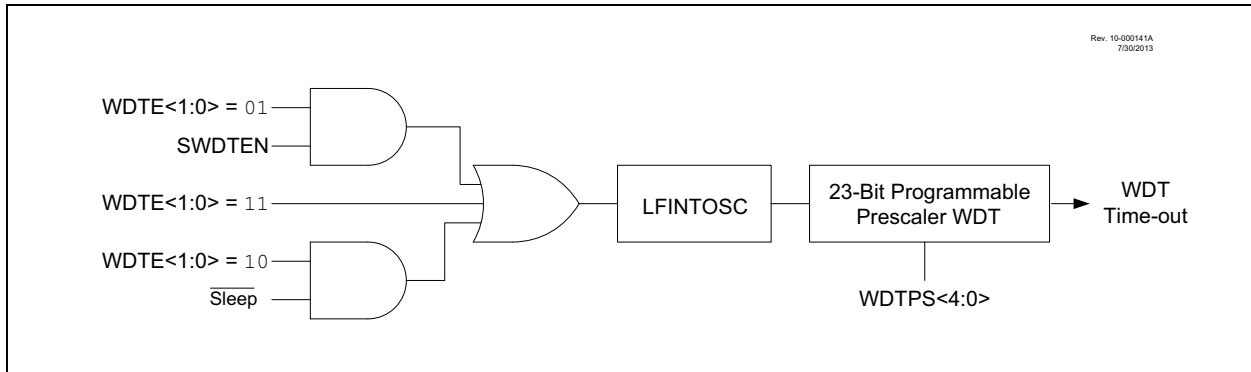

# PIC12(L)F1571/2

## 9.1 Independent Clock Source

The WDT derives its time base from the 31 kHz LFINTOSC internal oscillator. Time intervals in this chapter are based on a nominal interval of 1 ms. See [Section 26.0 “Electrical Specifications”](#) for the LFINTOSC tolerances.

## 9.2 WDT Operating Modes

The Watchdog Timer module has four operating modes controlled by the WDTE<1:0> bits in the Configuration Words. See [Table 9-1](#).

### 9.2.1 WDT IS ALWAYS ON

When the WDTE<sub>x</sub> bits of the Configuration Words are set to ‘11’, the WDT is always on. WDT protection is active during Sleep.

### 9.2.2 WDT IS OFF IN SLEEP

When the WDTE<sub>x</sub> bits of the Configuration Words are set to ‘10’, the WDT is on, except in Sleep. WDT protection is not active during Sleep.

### 9.2.3 WDT CONTROLLED BY SOFTWARE

When the WDTE<sub>x</sub> bits of the Configuration Words are set to ‘01’, the WDT is controlled by the SWDTEN bit of the WDTCON register.

WDT protection is unchanged by Sleep. See [Table 9-1](#) for more details.

**TABLE 9-1: WDT OPERATING MODES**

WDTE<1:0>	SWDTEN	Device Mode	WDT Mode
11	X	X	Active
10	X	Awake	Active
		Sleep	Disabled
01	1	X	Active
	0	X	Disabled
00	X	X	Disabled

**TABLE 9-2: WDT CLEARING CONDITIONS**

Conditions	WDT
WDTE<1:0> = 00	Cleared
WDTE<1:0> = 01 and SWDTEN = 0	
WDTE<1:0> = 10 and enter Sleep	
CLRWDT Command	
Oscillator Fail Detected	
Exit Sleep + System Clock = T1OSC, EXTRC, INTOSC, EXTCLK	
Exit Sleep + System Clock = XT, HS, LP	Cleared until the end of OST
Change INTOSC divider (IRCF<3:0> bits)	Unaffected

## 9.3 Time-out Period

The WDTPS<4:0> bits of the WDTCON register set the time-out period from 1 ms to 256 seconds (nominal). After a Reset, the default time-out period is two seconds.

## 9.4 Clearing the WDT

The WDT is cleared when any of the following conditions occur:

- Any Reset
- CLRWDT instruction is executed
- Device enters Sleep
- Device wakes up from Sleep
- Oscillator fails
- WDT is disabled
- Oscillator Start-up Timer (OST) is running

See [Table 9-2](#) for more information.

## 9.5 Operation During Sleep

When the device enters Sleep, the WDT is cleared. If the WDT is enabled during Sleep, the WDT resumes counting. When the device exits Sleep, the WDT is cleared again.

The WDT remains clear until the OST, if enabled, completes. See [Section 5.0 “Oscillator Module”](#) for more information on the OST.

When a WDT time-out occurs while the device is in Sleep, no Reset is generated. Instead, the device wakes up and resumes operation. The  $\overline{TO}$  and  $\overline{PD}$  bits in the STATUS register are changed to indicate the event. The RWDT bit in the PCON register can also be used. See [Section 3.0 “Memory Organization”](#) for more information.



## 9.6 Register Definitions: Watchdog Control

### REGISTER 9-1: WDTCON: WATCHDOG TIMER CONTROL REGISTER

U-0	U-0	R/W-0/0	R/W-1/1	R/W-0/0	R/W-1/1	R/W-1/1	R/W-0/0
—	—	WDTPS<4:0>					SWDTEN
bit 7							bit 0

#### Legend:

R = Readable bit	W = Writable bit	
u = Bit is unchanged	x = Bit is unknown	U = Unimplemented bit, read as '0'
'1' = Bit is set	'0' = Bit is cleared	-n/n = Value at POR and BOR/Value at all other Resets

bit 7-6 **Unimplemented:** Read as '0'

bit 5-1 **WDTPS<4:0>:** Watchdog Timer Period Select bits<sup>(1)</sup>

#### Bit Value = Prescale Rate

11111 = Reserved; results in minimum interval (1:32)

•

•

•

10011 = Reserved; results in minimum interval (1:32)

10010 = 1:8388608 ( $2^{23}$ ) (Interval 256s nominal)

10001 = 1:4194304 ( $2^{22}$ ) (Interval 128s nominal)

10000 = 1:2097152 ( $2^{21}$ ) (Interval 64s nominal)

01111 = 1:1048576 ( $2^{20}$ ) (Interval 32s nominal)

01110 = 1:524288 ( $2^{19}$ ) (Interval 16s nominal)

01101 = 1:262144 ( $2^{18}$ ) (Interval 8s nominal)

01100 = 1:131072 ( $2^{17}$ ) (Interval 4s nominal)

01011 = 1:65536 (Interval 2s nominal) (Reset value)

01010 = 1:32768 (Interval 1s nominal)

01001 = 1:16384 (Interval 512 ms nominal)

01000 = 1:8192 (Interval 256 ms nominal)

00111 = 1:4096 (Interval 128 ms nominal)

00110 = 1:2048 (Interval 64 ms nominal)

00101 = 1:1024 (Interval 32 ms nominal)

00100 = 1:512 (Interval 16 ms nominal)

00011 = 1:256 (Interval 8 ms nominal)

00010 = 1:128 (Interval 4 ms nominal)

00001 = 1:64 (Interval 2 ms nominal)

00000 = 1:32 (Interval 1 ms nominal)

bit 0 **SWDTEN:** Software Enable/Disable for Watchdog Timer bit

If WDTE<1:0> = 1x:

This bit is ignored.

If WDTE<1:0> = 01:

1 = WDT is turned on

0 = WDT is turned off

If WDTE<1:0> = 00:

This bit is ignored.

**Note 1:** Times are approximate. WDT time is based on 31 kHz LFINTOSC.

# PIC12(L)F1571/2

**TABLE 9-3: SUMMARY OF REGISTERS ASSOCIATED WITH WATCHDOG TIMER**

Name	Bit 7	Bit 6	Bit 5	Bit 4	Bit 3	Bit 2	Bit 1	Bit 0	Register on Page
OSCCON	SPLLEN	IRCF<3:0>			—		SCS<1:0>		55
PCON	STKOVF	STKUNF	—	$\overline{RWDT}$	$\overline{RMCLR}$	$\overline{RI}$	$\overline{POR}$	$\overline{BOR}$	66
STATUS	—	—	—	$\overline{TO}$	$\overline{PD}$	Z	DC	C	19
WDTCON	—	—	WDTPS<4:0>				SWDTEN		89

**Legend:** — = unimplemented location, read as '0'. Shaded cells are not used by the Watchdog Timer.

**TABLE 9-4: SUMMARY OF CONFIGURATION WORD WITH WATCHDOG TIMER**

Name	Bits	Bit -/7	Bit -/6	Bit 13/5	Bit 12/4	Bit 11/3	Bit 10/2	Bit 9/1	Bit 8/0	Register on Page
CONFIG1	13:8	—	—	—	—	$\overline{CLKOUTEN}$	BOREN<1:0>		—	42
	7:0	$\overline{CP}$	MCLRE	$\overline{PWRTE}$	WDTE<1:0>		—	FOSC<1:0>		

**Legend:** — = unimplemented location, read as '0'. Shaded cells are not used by the Watchdog Timer.

## 10.0 FLASH PROGRAM MEMORY CONTROL

The Flash program memory is readable and writable during normal operation over the full VDD range. Program memory is indirectly addressed using Special Function Registers (SFRs). The SFRs used to access program memory are:

- PMCON1
- PMCON2
- PMDATL
- PMDATH
- PMADRL
- PMADRH

When accessing the program memory, the PMDATH:PMDATL register pair forms a 2-byte word that holds the 14-bit data for read/write, and the PMADRH:PMADRL register pair forms a 2-byte word that holds the 15-bit address of the program memory location being read.

The write time is controlled by an on-chip timer. The write/erase voltages are generated by an on-chip charge pump.

The Flash program memory can be protected in two ways; by code protection ( $\overline{CP}$  bit in the Configuration Words) and write protection (WRT<1:0> bits in the Configuration Words).

Code protection ( $\overline{CP} = 0$ ) disables access, reading and writing, to the Flash program memory via external device programmers. Code protection does not affect the self-write and erase functionality. Code protection can only be reset by a device programmer performing a bulk erase to the device, clearing all Flash program memory, Configuration bits and User IDs.<sup>(1)</sup>

Write protection prohibits self-write and erase to a portion or all of the Flash program memory as defined by the bits WRT<1:0>. Write protection does not affect a device programmer's ability to read, write or erase the device.

**Note 1:** Code protection of the entire Flash program memory array is enabled by clearing the  $\overline{CP}$  bit of the Configuration Words.

## 10.1 PMADRL and PMADRH Registers

The PMADRH:PMADRL register pair can address up to a maximum of 16K words of program memory. When selecting a program address value, the MSB of the address is written to the PMADRH register and the LSB is written to the PMADRL register.

### 10.1.1 PMCON1 AND PMCON2 REGISTERS

PMCON1 is the control register for Flash program memory accesses.

Control bits, RD and WR, initiate read and write, respectively. These bits cannot be cleared, only set, in software. They are cleared by hardware at completion of the read or write operation. The inability to clear the WR bit in software prevents the accidental, premature termination of a write operation.

The WREN bit, when set, will allow a write operation to occur. On power-up, the WREN bit is clear. The WRERR bit is set when a write operation is interrupted by a Reset during normal operation. In these situations, following Reset, the user can check the WRERR bit and execute the appropriate error handling routine.

The PMCON2 register is a write-only register. Attempting to read the PMCON2 register will return all '0's.

To enable writes to the program memory, a specific pattern (the unlock sequence), must be written to the PMCON2 register. The required unlock sequence prevents inadvertent writes to the program memory write latches and Flash program memory.

## 10.2 Flash Program Memory Overview

It is important to understand the Flash program memory structure for erase and programming operations. Flash program memory is arranged in rows. A row consists of a fixed number of 14-bit program memory words. A row is the minimum size that can be erased by user software.

After a row has been erased, the user can reprogram all or a portion of this row. Data to be written into the program memory row is written to 14-bit wide data write latches. These write latches are not directly accessible to the user, but may be loaded via sequential writes to the PMDATH:PMDATL register pair.

**Note:** If the user wants to modify only a portion of a previously programmed row, then the contents of the entire row must be read and saved in RAM prior to the erase. Then, new data and retained data can be written into the write latches to reprogram the row of Flash program memory. However, any unprogrammed locations can be written without first erasing the row. In this case, it is not necessary to save and rewrite the other previously programmed locations.

# PIC12(L)F1571/2

See Table 10-1 for erase row size and the number of write latches for Flash program memory.

**TABLE 10-1: FLASH MEMORY ORGANIZATION BY DEVICE**

Device	Row Erase (words)	Write Latches (words)
PIC12(L)F1571	16	16
PIC12(L)F1572		

## 10.2.1 READING THE FLASH PROGRAM MEMORY

To read a program memory location, the user must:

1. Write the desired address to the PMADRH:PMADRL register pair.
2. Clear the CFGS bit of the PMCON1 register.
3. Then, set control bit, RD, of the PMCON1 register.

Once the read control bit is set, the program memory Flash controller will use the second instruction cycle to read the data. This causes the second instruction immediately following the “BSF PMCON1, RD” instruction to be ignored. The data is available in the very next cycle in the PMDATH:PMDATL register pair; therefore, it can be read as two bytes in the following instructions.

The PMDATH:PMDATL register pair will hold this value until another read or until it is written to by the user.

**Note:** The two instructions following a program memory read are required to be NOPs. This prevents the user from executing a 2-cycle instruction on the next instruction after the RD bit is set.

**FIGURE 10-1: FLASH PROGRAM MEMORY READ FLOWCHART**

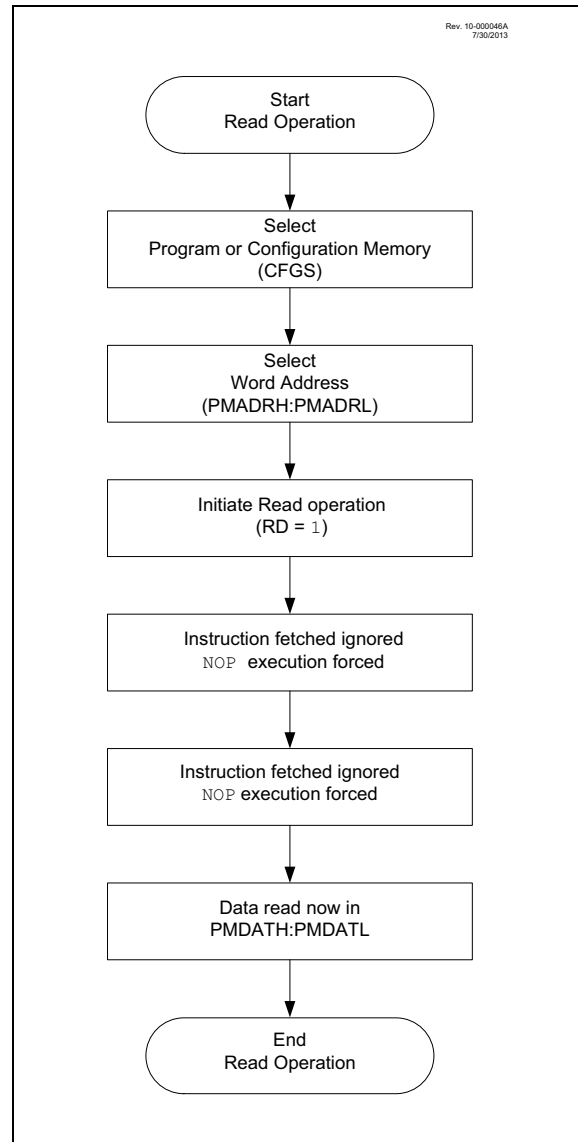

**FIGURE 10-2: FLASH PROGRAM MEMORY READ CYCLE EXECUTION**

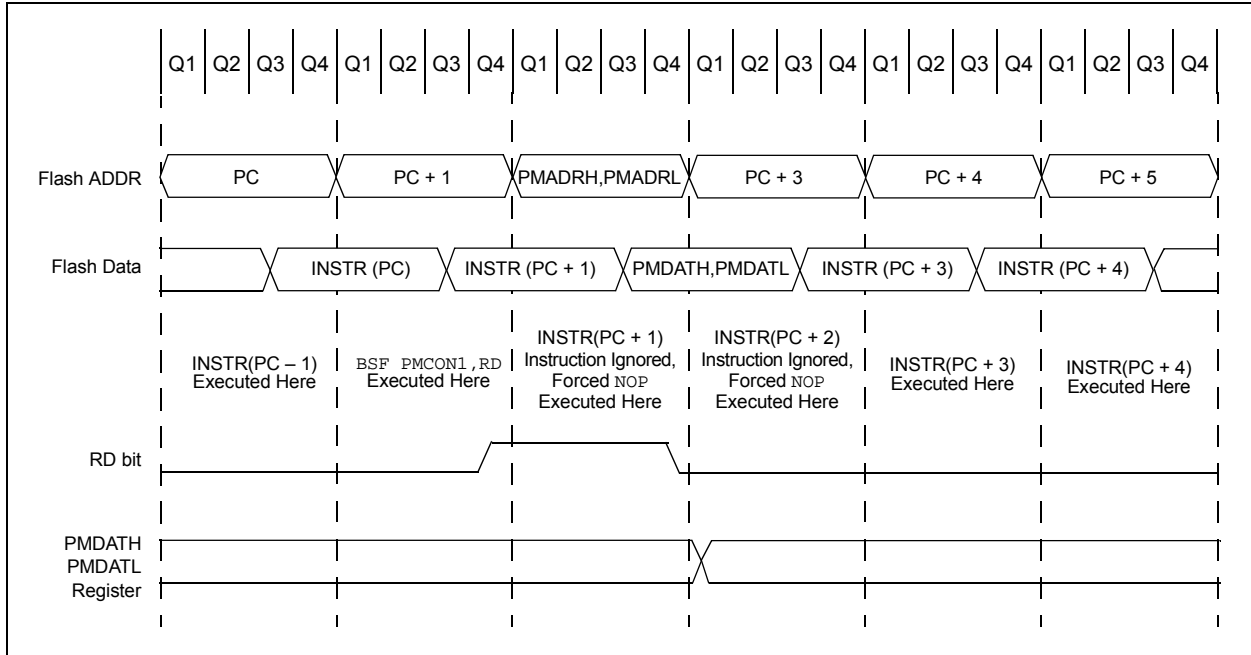

**EXAMPLE 10-1: FLASH PROGRAM MEMORY READ**

```

* This code block will read 1 word of program
* memory at the memory address:
  PROG_ADDR_HI : PROG_ADDR_LO
* data will be returned in the variables:
*  PROG_DATA_HI, PROG_DATA_LO

  BANKSEL  PMADRL          ; Select Bank for PMCON registers
  MOVLW   PROG_ADDR_LO    ;
  MOVWF   PMADRL          ; Store LSB of address
  MOVLW   PROG_ADDR_HI    ;
  MOVWF   PMADRH          ; Store MSB of address

  BCF     PMCON1,CFGS     ; Do not select Configuration Space
  BSF     PMCON1,RD       ; Initiate read
  NOP                                           ; Ignored (Figure 10-2)
  NOP                                           ; Ignored (Figure 10-2)

  MOVF    PMDATL,W        ; Get LSB of word
  MOVWF   PROG_DATA_LO    ; Store in user location
  MOVF    PMDATH,W        ; Get MSB of word
  MOVWF   PROG_DATA_HI    ; Store in user location

```

# PIC12(L)F1571/2

## 10.2.2 FLASH MEMORY UNLOCK SEQUENCE

The unlock sequence is a mechanism that protects the Flash program memory from unintended self-write programming or erasing. The sequence must be executed and completed without interruption to successfully complete any of the following operations:

- Row erase
- Load program memory write latches
- Write of program memory write latches to program memory
- Write of program memory write latches to User IDs

The unlock sequence consists of the following steps:

1. Write 55h to PMCON2
2. Write AAh to PMCON2
3. Set the WR bit in PMCON1
4. NOP instruction
5. NOP instruction

Once the WR bit is set, the processor will always force two NOP instructions. When an erase row or program row operation is being performed, the processor will stall internal operations (typical 2 ms), until the operation is complete and then resume with the next instruction. When the operation is loading the program memory write latches, the processor will always force the two NOP instructions and continue uninterrupted with the next instruction.

Since the unlock sequence must not be interrupted, global interrupts should be disabled prior to the unlock sequence and re-enabled after the unlock sequence is completed.

**FIGURE 10-3: FLASH PROGRAM MEMORY UNLOCK SEQUENCE FLOWCHART**

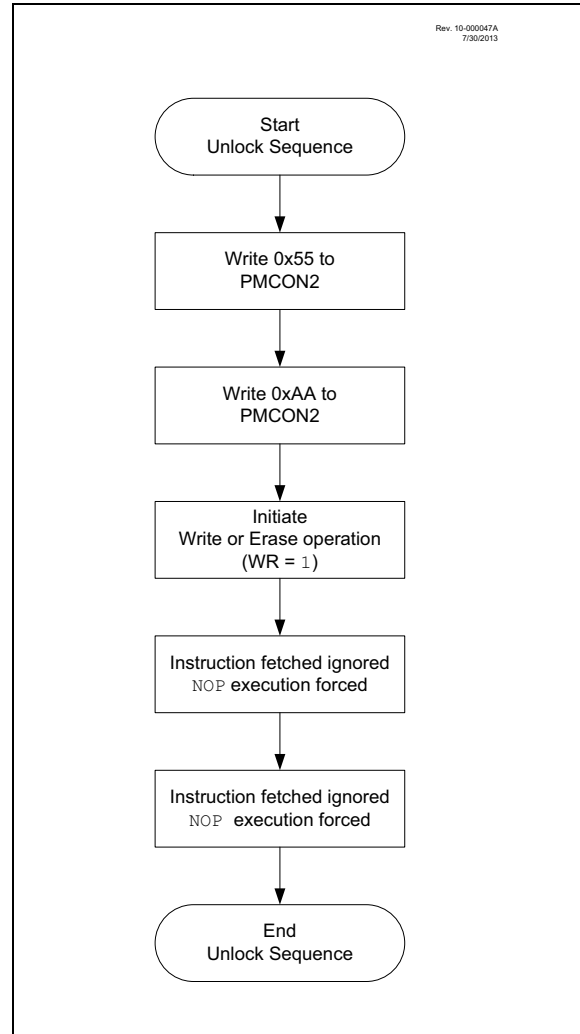

## 10.2.3 ERASING FLASH PROGRAM MEMORY

While executing code, program memory can only be erased by rows. To erase a row:

1. Load the PMADRH:PMADRL register pair with any address within the row to be erased.
2. Clear the CFGS bit of the PMCON1 register.
3. Set the FREE and WREN bits of the PMCON1 register.
4. Write 55h, then AAh, to PMCON2 (Flash programming unlock sequence).
5. Set control bit, WR, of the PMCON1 register to begin the erase operation.

See [Example 10-2](#).

After the “BSF PMCON1, WR” instruction, the processor requires two cycles to set up the erase operation. The user must place two NOP instructions after the WR bit is set. The processor will halt internal operations for the typical 2 ms erase time. This is not Sleep mode as the clocks and peripherals will continue to run. After the erase cycle, the processor will resume operation with the third instruction after the PMCON1 write instruction.

**FIGURE 10-4: FLASH PROGRAM MEMORY ERASE FLOWCHART**

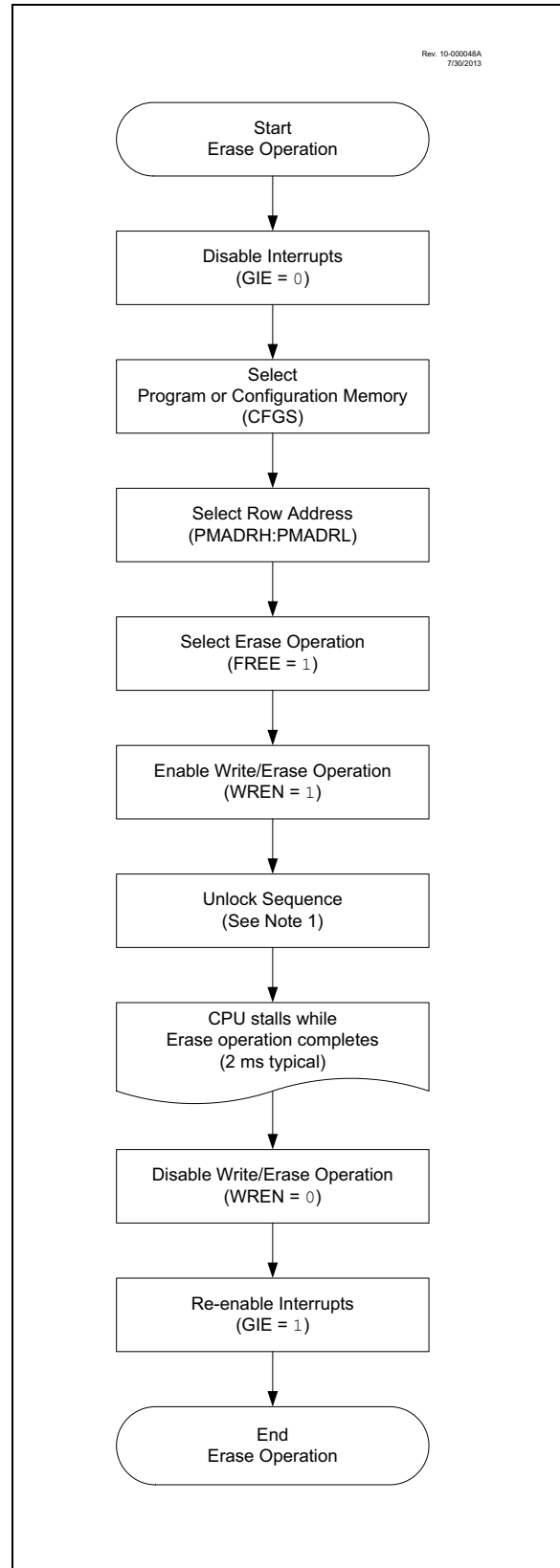

# PIC12(L)F1571/2

## EXAMPLE 10-2: ERASING ONE ROW OF PROGRAM MEMORY

```
; This row erase routine assumes the following:
; 1. A valid address within the erase row is loaded in ADDRH:ADDRL
; 2. ADDRH and ADDRL are located in shared data memory 0x70 - 0x7F (common RAM)

        BCF      INTCON,GIE      ; Disable ints so required sequences will execute properly
        BANKSEL PMADRL
        MOVF     ADDRL,W         ; Load lower 8 bits of erase address boundary
        MOVWF   PMADRL
        MOVF     ADDRH,W        ; Load upper 6 bits of erase address boundary
        MOVWF   PMADRH
        BCF     PMCON1,CFGSR     ; Not configuration space
        BSF     PMCON1,FREER     ; Specify an erase operation
        BSF     PMCON1,WREN      ; Enable writes

        MOVLW   55h             ; Start of required sequence to initiate erase
        MOVWF   PMCON2         ; Write 55h
        MOVLW   0AAh           ;
        MOVWF   PMCON2         ; Write AAh
        BSF     PMCON1,WR       ; Set WR bit to begin erase
        NOP                    ; NOP instructions are forced as processor starts
        NOP                    ; row erase of program memory.
        ;
        ; The processor stalls until the erase process is complete
        ; after erase processor continues with 3rd instruction

        BCF     PMCON1,WREN     ; Disable writes
        BSF     INTCON,GIE      ; Enable interrupts
```

Required  
Sequence



## 10.2.4 WRITING TO FLASH PROGRAM MEMORY

Program memory is programmed using the following steps:

1. Load the address in PMADRH:PMADRL of the row to be programmed.
2. Load each write latch with data.
3. Initiate a programming operation.
4. Repeat Steps 1 through 3 until all data is written.

Before writing to program memory, the word(s) to be written must be erased or previously unwritten. Program memory can only be erased one row at a time. No automatic erase occurs upon the initiation of the write.

Program memory can be written one or more words at a time. The maximum number of words written at one time is equal to the number of write latches. See [Figure 10-5](#) (row writes to program memory with 16 write latches) for more details.

The write latches are aligned to the Flash row address boundary defined by the upper 11 bits of PMADRH:PMADRL (PMADRH<6:0>:PMADRL<7:4>), with the lower 4 bits of PMADRL (PMADRL<3:0>) determining the write latch being loaded. Write operations do not cross these boundaries. At the completion of a program memory write operation, the data in the write latches is reset to contain 0x3FFF.

The following steps should be completed to load the write latches and program a row of program memory. These steps are divided into two parts. First, each write latch is loaded with data from the PMDATH:PMDATL using the unlock sequence with LWLO = 1. When the last word to be loaded into the write latch is ready, the LWLO bit is cleared and the unlock sequence executed. This initiates the programming operation, writing all the latches into Flash program memory.

**Note:** The special unlock sequence is required to load a write latch with data or initiate a Flash programming operation. If the unlock sequence is interrupted, writing to the latches or program memory will not be initiated.

1. Set the WREN bit of the PMCON1 register.
2. Clear the CFGS bit of the PMCON1 register.
3. Set the LWLO bit of the PMCON1 register. When the LWLO bit of the PMCON1 register is '1', the write sequence will only load the write latches and will not initiate the write to Flash program memory.
4. Load the PMADRH:PMADRL register pair with the address of the location to be written.
5. Load the PMDATH:PMDATL register pair with the program memory data to be written.
6. Execute the unlock sequence ([Section 10.2.2 "Flash Memory Unlock Sequence"](#)). The write latch is now loaded.
7. Increment the PMADRH:PMADRL register pair to point to the next location.
8. Repeat Steps 5 through 7 until all but the last write latch has been loaded.
9. Clear the LWLO bit of the PMCON1 register. When the LWLO bit of the PMCON1 register is '0', the write sequence will initiate the write to Flash program memory.
10. Load the PMDATH:PMDATL register pair with the program memory data to be written.
11. Execute the unlock sequence ([Section 10.2.2 "Flash Memory Unlock Sequence"](#)). The entire program memory latch content is now written to Flash program memory.

**Note:** The program memory write latches are reset to the blank state (0x3FFF) at the completion of every write or erase operation. As a result, it is not necessary to load all the program memory write latches. Unloaded latches will remain in the blank state.

An example of the complete write sequence is shown in [Example 10-3](#). The initial address is loaded into the PMADRH:PMADRL register pair; the data is loaded using Indirect Addressing.

**FIGURE 10-5: BLOCK WRITES TO FLASH PROGRAM MEMORY WITH 16 WRITE LATCHES**

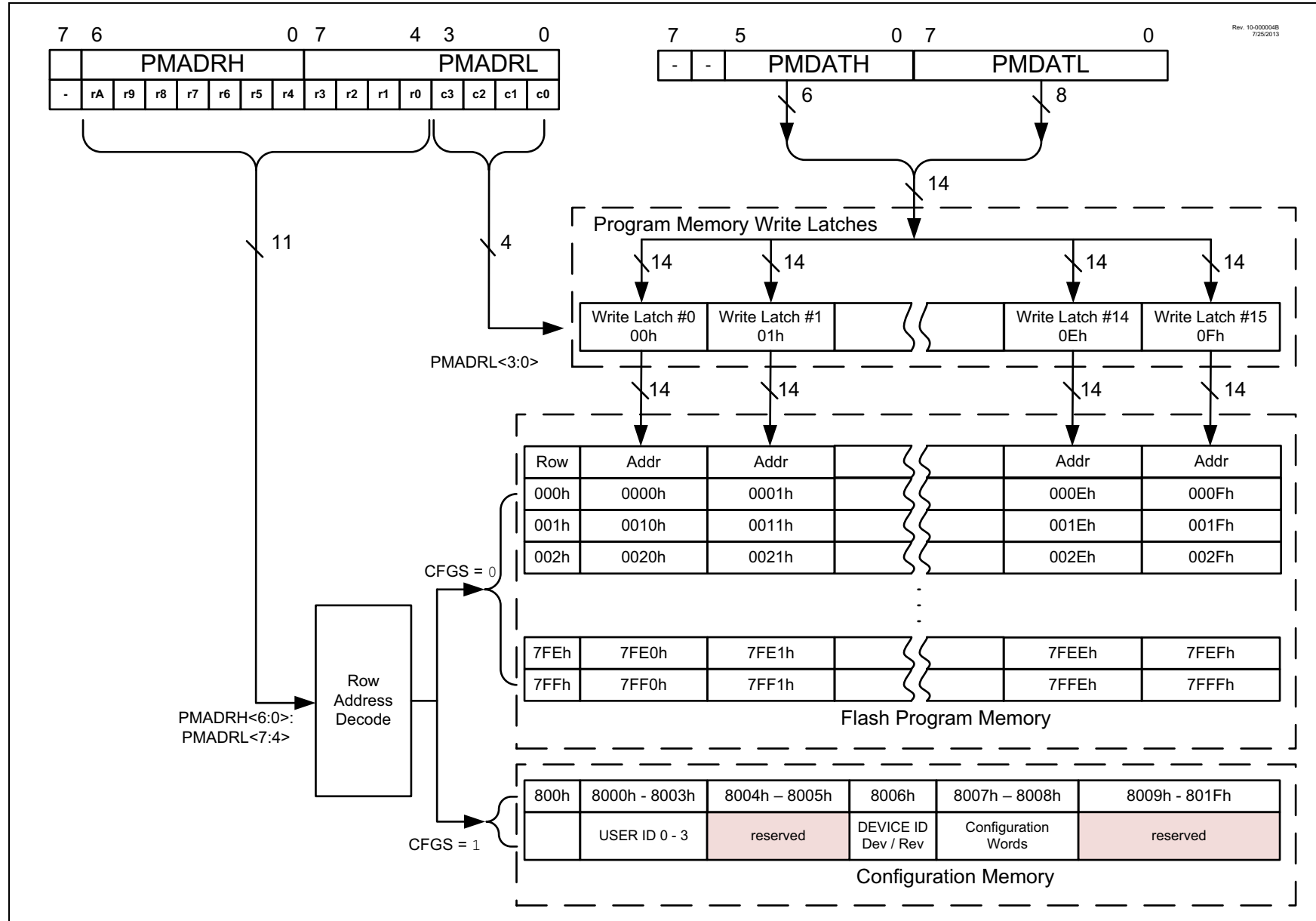

Rev. 10-000054B  
7/25/2013

FIGURE 10-6: FLASH PROGRAM MEMORY WRITE FLOWCHART

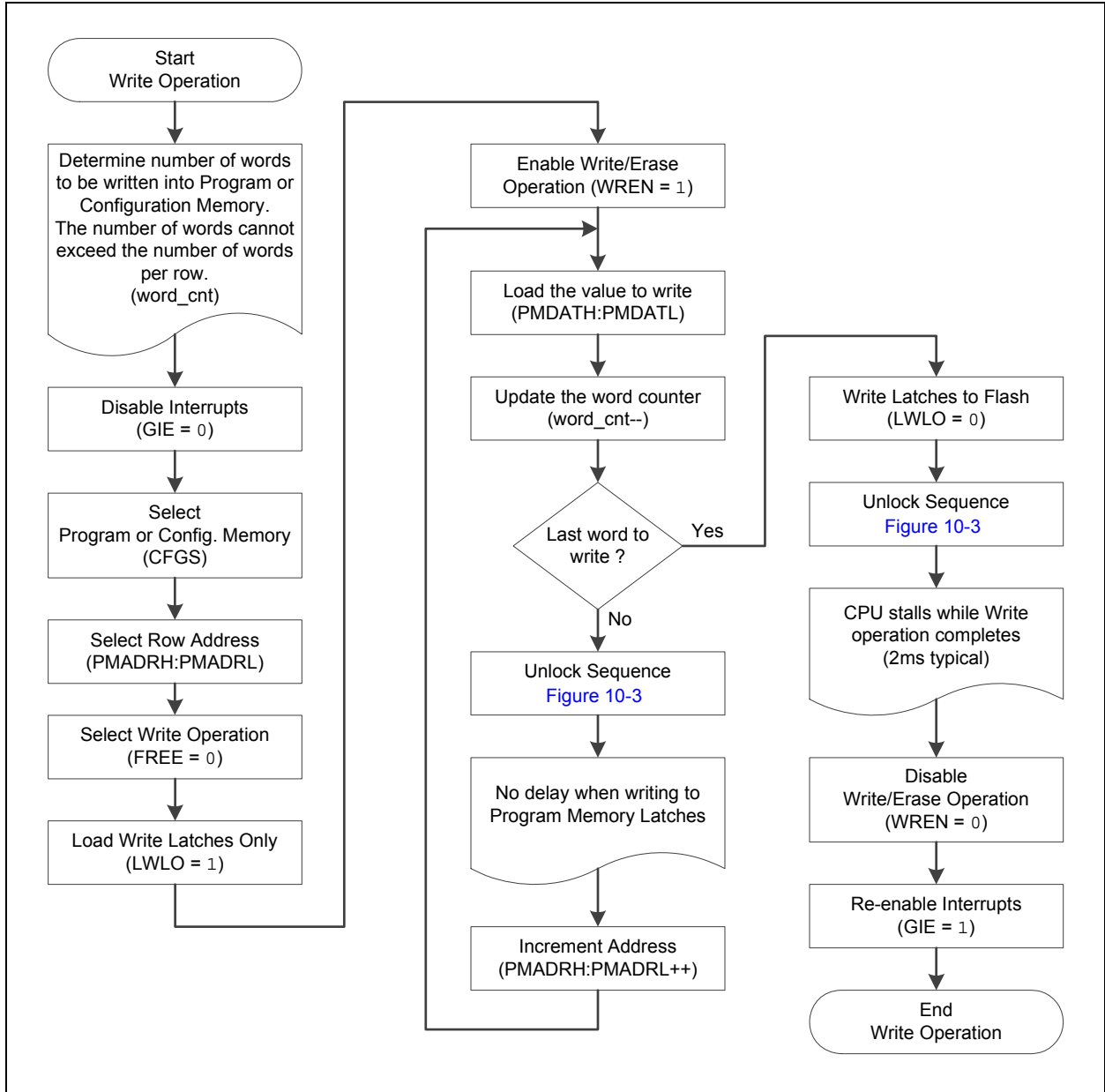

# PIC12(L)F1571/2

## EXAMPLE 10-3: WRITING TO FLASH PROGRAM MEMORY

```
; This write routine assumes the following:
; 1. 32 bytes of data are loaded, starting at the address in DATA_ADDR
; 2. Each word of data to be written is made up of two adjacent bytes in DATA_ADDR,
; stored in little endian format
; 3. A valid starting address (the Least Significant bits = 00000) is loaded in ADDRH:ADDRL
; 4. ADDRH and ADDRL are located in shared data memory 0x70 - 0x7F (common RAM)
;
        BCF      INTCON,GIE      ; Disable ints so required sequences will execute properly
        BANKSEL  PMADRH         ; Bank 3
        MOVF     ADDRH,W         ; Load initial address
        MOVWF    PMADRH         ;
        MOVF     ADDRL,W        ;
        MOVWF    PMADRL        ;
        MOVLW   LOW DATA_ADDR  ; Load initial data address
        MOVWF    FSR0L         ;
        MOVLW   HIGH DATA_ADDR ; Load initial data address
        MOVWF    FSR0H         ;
        BCF     PMCON1,CFG5     ; Not configuration space
        BSF     PMCON1,WREN     ; Enable writes
        BSF     PMCON1,LWLO    ; Only Load Write Latches

LOOP
        MOVIW   FSR0++         ; Load first data byte into lower
        MOVWF   PMDATL        ;
        MOVIW   FSR0++         ; Load second data byte into upper
        MOVWF   PMDATH        ;

        MOVF    PMADRL,W      ; Check if lower bits of address are '00000'
        XORLW   0x1F          ; Check if we're on the last of 16 addresses
        ANDLW   0x1F          ;
        BTFSC   STATUS,Z      ; Exit if last of 16 words,
        GOTO    START_WRITE   ;

        MOVLW   55h           ; Start of required write sequence:
        MOVWF   PMCON2        ; Write 55h
        MOVLW   0AAh          ;
        MOVWF   PMCON2        ; Write AAh
        BSF     PMCON1,WR     ; Set WR bit to begin write
        NOP                    ; NOP instructions are forced as processor
        ; loads program memory write latches
        NOP                    ;

        INCF    PMADRL,F      ; Still loading latches Increment address
        GOTO    LOOP          ; Write next latches

START_WRITE
        BCF     PMCON1,LWLO    ; No more loading latches - Actually start Flash program
        ; memory write

        MOVLW   55h           ; Start of required write sequence:
        MOVWF   PMCON2        ; Write 55h
        MOVLW   0AAh          ;
        MOVWF   PMCON2        ; Write AAh
        BSF     PMCON1,WR     ; Set WR bit to begin write
        NOP                    ; NOP instructions are forced as processor writes
        ; all the program memory write latches simultaneously
        NOP                    ; to program memory.
        ; After NOPs, the processor
        ; stalls until the self-write process is complete
        ; after write processor continues with 3rd instruction

        BCF     PMCON1,WREN    ; Disable writes
        BSF     INTCON,GIE     ; Enable interrupts
```

## 10.3 Modifying Flash Program Memory

When modifying existing data in a program memory row, and data within that row must be preserved, it must first be read and saved in a RAM image. Program memory is modified using the following steps:

1. Load the starting address of the row to be modified.
2. Read the existing data from the row into a RAM image.
3. Modify the RAM image to contain the new data to be written into program memory.
4. Load the starting address of the row to be rewritten.
5. Erase the program memory row.
6. Load the write latches with data from the RAM image.
7. Initiate a programming operation.

**FIGURE 10-7: FLASH PROGRAM MEMORY MODIFY FLOWCHART**

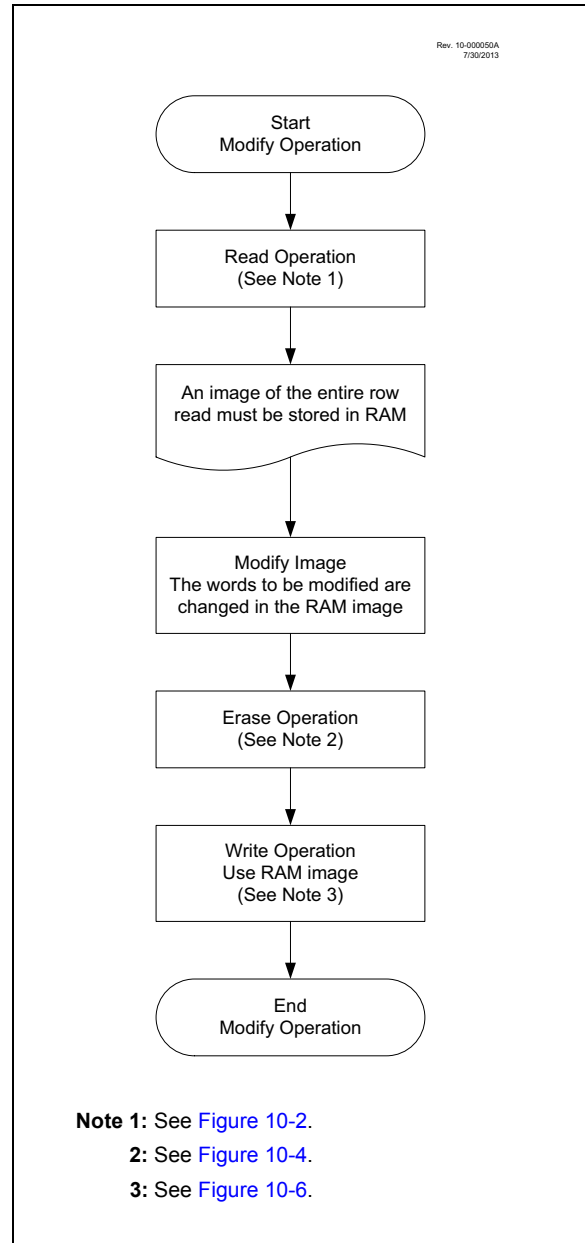

# PIC12(L)F1571/2

## 10.4 User ID, Device ID and Configuration Word Access

Instead of accessing program memory, the User IDs, Device ID/Revision ID and Configuration Words can be accessed when  $CFG5 = 1$  in the PMCON1 register. This is the region that would be pointed to by  $PC<15> = 1$ , but not all addresses are accessible. Different access may exist for reads and writes. Refer to [Table 10-2](#).

When read access is initiated on an address outside the parameters listed in [Table 10-2](#), the PMDATH:PMDATL register pair is cleared, reading back '0's.

**TABLE 10-2: USER ID, DEVICE ID AND CONFIGURATION WORD ACCESS (CFG5 = 1)**

Address	Function	Read Access	Write Access
8000h-8003h	User IDs	Yes	Yes
8006h/8005h	Device ID/Revision ID	Yes	No
8007h-8008h	Configuration Words 1 and 2	Yes	No

### EXAMPLE 10-4: CONFIGURATION WORD AND DEVICE ID ACCESS

```
* This code block will read 1 word of program memory at the memory address:
*   PROG_ADDR_LO (must be 00h-08h) data will be returned in the variables;
*   PROG_DATA_HI, PROG_DATA_LO

BANKSEL  PMADRL          ; Select correct Bank
MOVLW   PROG_ADDR_LO    ;
MOVWF   PMADRL          ; Store LSB of address
CLRF    PMADRH          ; Clear MSB of address

BSF     PMCON1,CFG5     ; Select Configuration Space
BCF     INTCON,GIE      ; Disable interrupts
BSF     PMCON1,RD       ; Initiate read
NOP     ; Executed (See Figure 10-2)
NOP     ; Ignored (See Figure 10-2)
BSF     INTCON,GIE      ; Restore interrupts

MOVF    PMDATL,W        ; Get LSB of word
MOVWF   PROG_DATA_LO    ; Store in user location
MOVF    PMDATH,W        ; Get MSB of word
MOVWF   PROG_DATA_HI    ; Store in user location
```

**10.5 Write Verify**

It is considered good programming practice to verify that program memory writes agree with the intended value. Since program memory is stored as a full page then the stored program memory contents are compared with the intended data stored in RAM after the last write is complete.

**FIGURE 10-8: FLASH PROGRAM MEMORY VERIFY FLOWCHART**

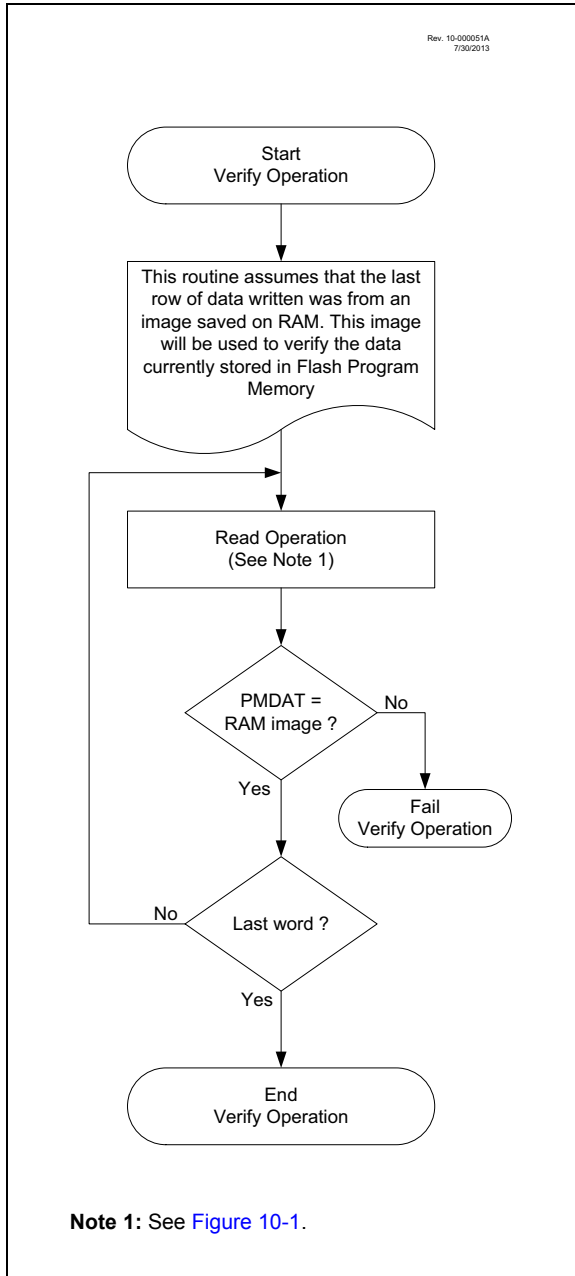

# PIC12(L)F1571/2

## 10.6 Register Definitions: Flash Program Memory Control

### REGISTER 10-1: PMDATL: PROGRAM MEMORY DATA LOW BYTE REGISTER

R/W-x/u	R/W-x/u	R/W-x/u	R/W-x/u	R/W-x/u	R/W-x/u	R/W-x/u	R/W-x/u
PMDAT<7:0>							
bit 7							bit 0

**Legend:**

R = Readable bit                      W = Writable bit  
u = Bit is unchanged                  x = Bit is unknown                  U = Unimplemented bit, read as '0'  
'1' = Bit is set                          '0' = Bit is cleared                  -n/n = Value at POR and BOR/Value at all other Resets

bit 7-0                  **PMDAT<7:0>**: Read/Write Value for Least Significant bits of Program Memory bits

### REGISTER 10-2: PMDATH: PROGRAM MEMORY DATA HIGH BYTE REGISTER

U-0	U-0	R/W-x/u	R/W-x/u	R/W-x/u	R/W-x/u	R/W-x/u	R/W-x/u
—	—	PMDAT<13:8>					
bit 7							bit 0

**Legend:**

R = Readable bit                      W = Writable bit  
u = Bit is unchanged                  x = Bit is unknown                  U = Unimplemented bit, read as '0'  
'1' = Bit is set                          '0' = Bit is cleared                  -n/n = Value at POR and BOR/Value at all other Resets

bit 7-6                  **Unimplemented**: Read as '0'

bit 5-0                  **PMDAT<13:8>**: Read/Write Value for Most Significant bits of Program Memory bits



## REGISTER 10-3: PMADRL: PROGRAM MEMORY ADDRESS LOW BYTE REGISTER

R/W-0/0	R/W-0/0	R/W-0/0	R/W-0/0	R/W-0/0	R/W-0/0	R/W-0/0	R/W-0/0
PMADR<7:0>							
bit 7							bit 0

### Legend:

R = Readable bit	W = Writable bit	
u = Bit is unchanged	x = Bit is unknown	U = Unimplemented bit, read as '0'
'1' = Bit is set	'0' = Bit is cleared	-n/n = Value at POR and BOR/Value at all other Resets

bit 7-0      **PMADR<7:0>**: Specifies Least Significant bits for Program Memory Address bits

## REGISTER 10-4: PMADRH: PROGRAM MEMORY ADDRESS HIGH BYTE REGISTER

U-1	R/W-0/0	R/W-0/0	R/W-0/0	R/W-0/0	R/W-0/0	R/W-0/0	R/W-0/0
__ <sup>(1)</sup>	PMADR<14:8>						
bit 7							bit 0

### Legend:

R = Readable bit	W = Writable bit	
u = Bit is unchanged	x = Bit is unknown	U = Unimplemented bit, read as '0'
'1' = Bit is set	'0' = Bit is cleared	-n/n = Value at POR and BOR/Value at all other Resets

bit 7      **Unimplemented:** Read as '1'<sup>(1)</sup>

bit 6-0      **PMADR<14:8>**: Specifies the Most Significant bits for Program Memory Address bits

**Note 1:** Unimplemented, read as '1'.

# PIC12(L)F1571/2

## REGISTER 10-5: PMCON1: PROGRAM MEMORY CONTROL 1 REGISTER

U-1	R/W-0/0	R/W-0/0	R/W/HC-0/0	R/W/HC-x/q <sup>(2)</sup>	R/W-0/0	R/S/HC-0/0	R/S/HC-0/0
— <sup>(1)</sup>	CFGS	LWLO <sup>(3)</sup>	FREE	WRERR	WREN	WR	RD
bit 7							bit 0

### Legend:

R = Readable bit	W = Writable bit	U = Unimplemented bit, read as '0'
S = Bit can only be set	x = Bit is unknown	-n/n = Value at POR and BOR/Value at all other Resets
'1' = Bit is set	'0' = Bit is cleared	HC = Hardware Clearable bit

- bit 7      **Unimplemented:** Read as '1'<sup>(1)</sup>
- bit 6      **CFGS:** Configuration Select bit  
             1 = Accesses Configuration, User ID and Device ID registers  
             0 = Accesses Flash program memory
- bit 5      **LWLO:** Load Write Latches Only bit<sup>(3)</sup>  
             1 = Only the addressed program memory write latch is loaded/updated on the next WR command  
             0 = The addressed program memory write latch is loaded/updated and a write of all program memory write latches will be initiated on the next WR command
- bit 4      **FREE:** Program Flash Erase Enable bit  
             1 = Performs an erase operation on the next WR command (hardware cleared upon completion)  
             0 = Performs a write operation on the next WR command
- bit 3      **WRERR:** Program/Erase Error Flag bit<sup>(2)</sup>  
             1 = Condition indicates an improper program or erase sequence attempt or termination (bit is set automatically on any set attempt (writes '1') of the WR bit)  
             0 = The program or erase operation completed normally
- bit 2      **WREN:** Program/Erase Enable bit  
             1 = Allows program/erase cycles  
             0 = Inhibits programming/erasing of program Flash
- bit 1      **WR:** Write Control bit  
             1 = Initiates a program Flash program/erase operation  
                 The operation is self-timed and the bit is cleared by hardware once operation is complete. The WR bit can only be set (not cleared) in software.  
             0 = Program/erase operation to the Flash is complete and inactive
- bit 0      **RD:** Read Control bit  
             1 = Initiates a program Flash read  
                 Read takes one cycle. RD is cleared in hardware. The RD bit can only be set (not cleared) in software.  
             0 = Does not initiate a program Flash read

**Note 1:** Unimplemented bit, read as '1'.

**Note 2:** The WRERR bit is automatically set by hardware when a program memory write or erase operation is started (WR = 1).

**Note 3:** The LWLO bit is ignored during a program memory erase operation (FREE = 1).

## REGISTER 10-6: PMCON2: PROGRAM MEMORY CONTROL 2 REGISTER

W-0/0	W-0/0	W-0/0	W-0/0	W-0/0	W-0/0	W-0/0	W-0/0
Program Memory Control Register 2							
bit 7							bit 0

### Legend:

R = Readable bit	W = Writable bit	
S = Bit can only be set	x = Bit is unknown	U = Unimplemented bit, read as '0'
'1' = Bit is set	'0' = Bit is cleared	-n/n = Value at POR and BOR/Value at all other Resets

### bit 7-0 Flash Memory Unlock Pattern bits

To unlock writes, a 55h must be written first, followed by an AAh, before setting the WR bit of the PMCON1 register. The value written to this register is used to unlock the writes. There are specific timing requirements on these writes.

**TABLE 10-3: SUMMARY OF REGISTERS ASSOCIATED WITH FLASH PROGRAM MEMORY**

Name	Bit 7	Bit 6	Bit 5	Bit 4	Bit 3	Bit 2	Bit 1	Bit 0	Register on Page
INTCON	GIE	PEIE	TMR0IE	INTE	IOCIE	TMR0IF	INTF	IOCIF	74
PMCON1	— <sup>(1)</sup>	CFGS	LWLO	FREE	WRERR	WREN	WR	RD	106
PMCON2	Program Memory Control Register 2								107
PMADRL	PMADRL<7:0>								105
PMADRH	— <sup>(1)</sup>	PMADRH<6:0>							105
PMDATL	PMDATL<7:0>								104
PMDATH	—	—	PMDATH<5:0>						104

**Legend:** — = unimplemented location, read as '0'. Shaded cells are not used by Flash program memory.

**Note 1:** Unimplemented, read as '1'.

**TABLE 10-4: SUMMARY OF CONFIGURATION WORD WITH FLASH PROGRAM MEMORY**

Name	Bits	Bit -/7	Bit -/6	Bit 13/5	Bit 12/4	Bit 11/3	Bit 10/2	Bit 9/1	Bit 8/0	Register on Page
CONFIG1	13:8	—	—	—	—	CLKOUTEN	BOREN<1:0>		—	42
	7:0	CP	MCLRE	PWRTE	WDTE<1:0>		—	FOSC<1:0>		
CONFIG2	13:8	—	—	LVP	DEBUG	LPBOR	BORV	STVREN	PLEN	43
	7:0	—	—	—	—	—	WRT<1:0>			

**Legend:** — = unimplemented location, read as '0'. Shaded cells are not used by Flash program memory.

# PIC12(L)F1571/2

---

NOTES:

## 11.0 I/O PORTS

Each port has three standard registers for its operation. These registers are:

- TRISx registers (Data Direction)
- PORTx registers (reads the levels on the pins of the device)
- LATx registers (Output Latch)
- INLVLx (Input Level Control)
- ODCONx registers (Open-Drain Control)
- SLRCONx registers (Slew Rate Control)

Some ports may have one or more of the following additional registers. These registers are:

- ANSELx (Analog Select)
- WPUx (Weak Pull-up)

In general, when a peripheral is enabled on a port pin, that pin cannot be used as a general purpose output. However, the pin can still be read.

**TABLE 11-1: PORT AVAILABILITY PER DEVICE**

Device	PORTA
PIC12(L)F1571	•
PIC12(L)F1572	•

The Data Latch (LATx registers) is useful for Read-Modify-Write operations on the value that the I/O pins are driving.

A write operation to the LATx register has the same effect as a write to the corresponding PORTx register. A read of the LATx register reads the values held in the I/O port latches, while a read of the PORTx register reads the actual I/O pin value.

Ports that support analog inputs have an associated ANSELx register. When an ANSELx bit is set, the digital input buffer associated with that bit is disabled. Disabling the input buffer prevents analog signal levels on the pin between a logic high and low from causing excessive current in the logic input circuitry. A simplified model of a generic I/O port, without the interfaces to other peripherals, is shown in Figure 11-1.

**FIGURE 11-1: GENERIC I/O PORT OPERATION**

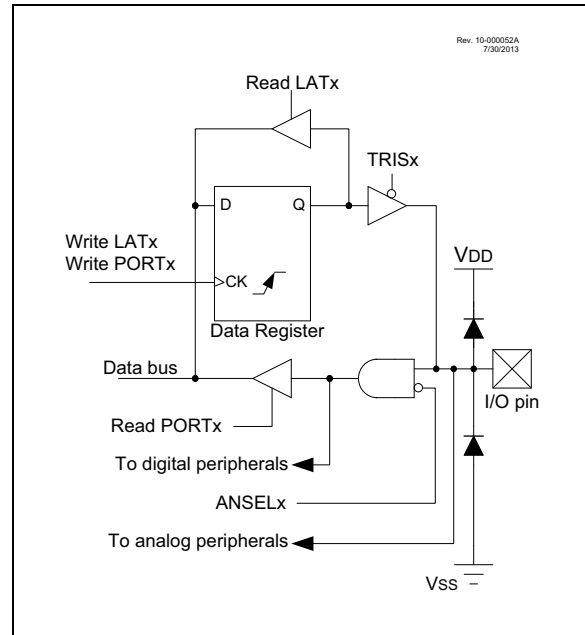

# PIC12(L)F1571/2

## 11.1 Alternate Pin Function

The Alternate Pin Function Control (APFCON) register is used to steer specific peripheral input and output functions between different pins. The APFCON register is shown in [Register 11-1](#). For this device family, the following functions can be moved between different pins.

- RX/DT
- TX/CK
- CWGOUTA
- CWGOUTB
- PWM2
- PWM1

These bits have no effect on the values of any TRISx register. PORTx and TRISx overrides will be routed to the correct pin. The unselected pin will be unaffected.

## 11.2 Register Definitions: Alternate Pin Function Control

### REGISTER 11-1: APFCON: ALTERNATE PIN FUNCTION CONTROL REGISTER

R/W-0/0	R/W-0/0	R/W-0/0	U-0	R/W-0/0	R/W-0/0	R/W-0/0	R/W-0/0
RXDTSEL	CWGASEL	CWGBSEL	—	T1GSEL	TXCKSEL	P2SEL	P1SEL
bit 7							bit 0

#### Legend:

R = Readable bit

W = Writable bit

u = Bit is unchanged

x = Bit is unknown

U = Unimplemented bit, read as '0'

'1' = Bit is set

'0' = Bit is cleared

-n/n = Value at POR and BOR/Value at all other Resets

bit 7	<b>RXDTSEL:</b> Pin Selection bit 1 = RX/DT function is on RA5 0 = RX/DT function is on RA1
bit 6	<b>CWGASEL:</b> Pin Selection bit 1 = CWGOUTA function is on RA5 0 = CWGOUTA function is on RA2
bit 5	<b>CWGBSEL:</b> Pin Selection bit 1 = CWGOUTB function is on RA4 0 = CWGOUTB function is on RA0
bit 4	<b>Unimplemented:</b> Read as '0'
bit 3	<b>T1GSEL:</b> Pin Selection bit 1 = T1G function is on RA3 0 = T1G function is on RA4
bit 2	<b>TXCKSEL:</b> Pin Selection bit 1 = TX/CK function is on RA4 0 = TX/CK function is on RA0
bit 1	<b>P2SEL:</b> Pin Selection bit 1 = PWM2 function is on RA4 0 = PWM2 function is on RA0
bit 0	<b>P1SEL:</b> Pin Selection bit 1 = PWM1 function is on RA5 0 = PWM1 function is on RA1

## 11.3 PORTA Registers

### 11.3.1 DATA REGISTER

PORTA is a 6-bit wide, bidirectional port. The corresponding Data Direction register is TRISA (Register 11-3). Setting a TRISA bit (= 1) will make the corresponding PORTA pin an input (i.e., disable the output driver). Clearing a TRISA bit (= 0) will make the corresponding PORTA pin an output (i.e., enables output driver and puts the contents of the output latch on the selected pin). The exception is RA3, which is input-only and its TRISA bit will always read as '1'. Example 11-1 shows how to initialize an I/O port.

Reading the PORTA register (Register 11-2) reads the status of the pins, whereas writing to it will write to the PORT latch. All write operations are Read-Modify-Write operations. Therefore, a write to a port implies that the port pins are read, this value is modified and then written to the Port Data Latch (LATA).

### 11.3.2 DIRECTION CONTROL

The TRISA register (Register 11-3) controls the PORTA pin output drivers, even when they are being used as analog inputs. The user should ensure the bits in the TRISA register are maintained set when using them as analog inputs. I/O pins configured as analog input always read '0'.

### 11.3.3 OPEN-DRAIN CONTROL

The ODCONA register (Register 11-7) controls the open-drain feature of the port. Open-drain operation is independently selected for each pin. When an ODCONA bit is set, the corresponding port output becomes an open-drain driver capable of sinking current only. When an ODCONA bit is cleared, the corresponding port output pin is the standard push-pull drive capable of sourcing and sinking current.

### 11.3.4 SLEW RATE CONTROL

The SLRCONA register (Register 11-8) controls the slew rate option for each port pin. Slew rate control is independently selectable for each port pin. When an SLRCONA bit is set, the corresponding port pin drive is slew rate limited. When an SLRCONA bit is cleared, the corresponding port pin drive slews at the maximum rate possible.

### 11.3.5 INPUT THRESHOLD CONTROL

The INLVLA register (Register 11-9) controls the input voltage threshold for each of the available PORTA input pins. A selection between the Schmitt Trigger CMOS or the TTL compatible thresholds is available. The input threshold is important in determining the value of a read of the PORTA register and also the level at which an Interrupt-On-Change occurs, if that feature is enabled. See Section 26.3 "DC Characteristics" for more information on threshold levels.

**Note:** Changing the input threshold selection should be performed while all peripheral modules are disabled. Changing the threshold level during the time a module is active may inadvertently generate a transition associated with an input pin, regardless of the actual voltage level on that pin.

### 11.3.6 ANALOG CONTROL

The ANSELA register (Register 11-5) is used to configure the Input mode of an I/O pin to analog. Setting the appropriate ANSELA bit high will cause all digital reads on the pin to be read as '0' and allow analog functions on the pin to operate correctly.

The state of the ANSELA bits has no effect on digital output functions. A pin with TRIS clear and ANSELA set will still operate as a digital output, but the Input mode will be analog. This can cause unexpected behavior when executing Read-Modify-Write instructions on the affected port.

**Note:** The ANSELA bits default to the Analog mode after Reset. To use any pins as digital general purpose or peripheral inputs, the corresponding ANSELA bits must be initialized to '0' by user software.

#### EXAMPLE 11-1: INITIALIZING PORTA

```
BANKSEL PORTA      ;
CLRF PORTA         ;Init PORTA
BANKSEL LATA       ;Data Latch
CLRF LATA          ;
BANKSEL ANSELA     ;
CLRF ANSELA       ;digital I/O
BANKSEL TRISA      ;
MOVLW B'00111000' ;Set RA<5:3> as inputs
MOVWF TRISA        ;and set RA<2:0> as
                   ;outputs
```

# PIC12(L)F1571/2

## 11.3.7 PORTA FUNCTIONS AND OUTPUT PRIORITIES

Each PORTA pin is multiplexed with other functions. The pins, their combined functions and their output priorities are shown in [Table 11-2](#).

When multiple outputs are enabled, the actual pin control goes to the peripheral with the highest priority.

Analog input functions, such as ADC and comparator inputs, are not shown in the priority lists. These inputs are active when the I/O pin is set for Analog mode using the ANSELx registers. Digital output functions may control the pin when it is in Analog mode with the priority shown below in [Table 11-2](#).

**TABLE 11-2: PORTA OUTPUT PRIORITY**

Pin Name	Function Priority <sup>(1)</sup>
RA0	ICSPDAT CWG1B <sup>(3)</sup> DAC1OUT TX <sup>(2,3)</sup> PWM2 <sup>(3)</sup> RA0
RA1	PWM1 <sup>(3)</sup> RA1
RA2	CWG1A CWG1FLT C1OUT PWM3 RA2
RA3	None
RA4	CLKOUT CWG1B TX <sup>(2)</sup> PWM2 RA4
RA5	CWG1A PWM1 RA5

- Note 1:** Priority listed from highest to lowest.  
**Note 2:** PIC12(L)F1572 only.  
**Note 3:** Default pin (see APFCON register).



## 11.4 Register Definitions: PORTA

### REGISTER 11-2: PORTA: PORTA REGISTER

U-0	U-0	R/W-x/x	R/W-x/x	R-x/x	R/W-x/x	R/W-x/x	R/W-x/x
—	—	RA<5:0>					
bit 7							bit 0

#### Legend:

R = Readable bit	W = Writable bit	
u = Bit is unchanged	x = Bit is unknown	U = Unimplemented bit, read as '0'
'1' = Bit is set	'0' = Bit is cleared	-n/n = Value at POR and BOR/Value at all other Resets

bit 7-6      **Unimplemented:** Read as '0'

bit 5-0      **RA<5:0>:** PORTA I/O Value bits<sup>(1)</sup>  
                  1 = Port pin is  $\geq$  VIH  
                  0 = Port pin is  $\leq$  VIL

**Note 1:** Writes to PORTA are actually written to corresponding LATA register. Reads from the PORTA register are the return of actual I/O pin values.

### REGISTER 11-3: TRISA: PORTA TRI-STATE REGISTER

U-0	U-0	R/W-1/1	R/W-1/1	U-1	R/W-1/1	R/W-1/1	R/W-1/1
—	—	TRISA<5:4>		— <sup>(1)</sup>	TRISA<2:0>		
bit 7							bit 0

#### Legend:

R = Readable bit	W = Writable bit	
u = Bit is unchanged	x = Bit is unknown	U = Unimplemented bit, read as '0'
'1' = Bit is set	'0' = Bit is cleared	-n/n = Value at POR and BOR/Value at all other Resets

bit 7-6      **Unimplemented:** Read as '0'

bit 5-4      **TRISA<5:4>:** PORTA Tri-State Control bits  
                  1 = PORTA pin configured as an input (tri-stated)  
                  0 = PORTA pin configured as an output

bit 3        **Unimplemented:** Read as '1'<sup>(1)</sup>

bit 2-0      **TRISA<2:0>:** PORTA Tri-State Control bits  
                  1 = PORTA pin configured as an input (tri-stated)  
                  0 = PORTA pin configured as an output

**Note 1:** Unimplemented, read as '1'.

# PIC12(L)F1571/2

## REGISTER 11-4: LATA: PORTA DATA LATCH REGISTER

U-0	U-0	R/W-x/u	R/W-x/u	U-0	R/W-x/u	R/W-x/u	R/W-x/u
—	—	LATA<5:4> <sup>(1)</sup>		—	LATA<2:0> <sup>(1)</sup>		
bit 7				bit 0			

### Legend:

R = Readable bit                      W = Writable bit  
u = Bit is unchanged                  x = Bit is unknown                  U = Unimplemented bit, read as '0'  
'1' = Bit is set                          '0' = Bit is cleared                  -n/n = Value at POR and BOR/Value at all other Resets

- bit 7-6            **Unimplemented:** Read as '0'
- bit 5-4            **LATA<5:4>:** RA<5:4> Output Latch Value bits<sup>(1)</sup>
- bit 3              **Unimplemented:** Read as '0'
- bit 2-0            **LATA<2:0>:** RA<2:0> Output Latch Value bits<sup>(1)</sup>

**Note 1:** Writes to PORTA are actually written to corresponding LATA register. Reads from the PORTA register are the return of actual I/O pin values.

## REGISTER 11-5: ANSELA: PORTA ANALOG SELECT REGISTER

U-0	U-0	U-0	R/W-1/1	U-0	R/W-1/1	R/W-1/1	R/W-1/1
—	—	—	ANSA4	—	ANSA<2:0>		
bit 7				bit 0			

### Legend:

R = Readable bit                      W = Writable bit  
u = Bit is unchanged                  x = Bit is unknown                  U = Unimplemented bit, read as '0'  
'1' = Bit is set                          '0' = Bit is cleared                  -n/n = Value at POR and BOR/Value at all other Resets

- bit 7-5            **Unimplemented:** Read as '0'
- bit 4              **ANSA4:** Analog Select Between Analog or Digital Function on RA4 Pins (respectively) bit
  - 1 = Analog input; pin is assigned as analog input, digital input buffer is disabled<sup>(1)</sup>
  - 0 = Digital I/O; pin is assigned to port or digital special function
- bit 3              **Unimplemented:** Read as '0'
- bit 2-0            **ANSA<2:0>:** Analog Select Between Analog or Digital Function on RA<2:0> pins (respectively) bits
  - 1 = Analog input; pin is assigned as analog input, digital input buffer is disabled<sup>(1)</sup>
  - 0 = Digital I/O; pin is assigned to port or digital special function

**Note 1:** When setting a pin to an analog input, the corresponding TRISx bit must be set to Input mode in order to allow external control of the voltage on the pin.

## REGISTER 11-6: WPUA: WEAK PULL-UP PORTA REGISTER

U-0	U-0	R/W-1/1	R/W-1/1	R/W-1/1	R/W-1/1	R/W-1/1	R/W-1/1
—	—	WPUA<5:0> <sup>(1,2,3)</sup>					
bit 7							bit 0

### Legend:

R = Readable bit	W = Writable bit	
u = Bit is unchanged	x = Bit is unknown	U = Unimplemented bit, read as '0'
'1' = Bit is set	'0' = Bit is cleared	-n/n = Value at POR and BOR/Value at all other Resets

- bit 7-6      **Unimplemented:** Read as '0'
- bit 5-0      **WPUA<5:0>:** Weak Pull-up Register bits<sup>(1,2,3)</sup>  
                   1 = Pull-up is enabled  
                   0 = Pull-up is disabled

- Note 1:** Global  $\overline{\text{WPUEN}}$  bit of the OPTION\_REG register must be cleared for individual pull-ups to be enabled.  
**2:** The weak pull-up device is automatically disabled if the pin is configured as an output.  
**3:** For the WPUA3 bit, when MCLRE = 1, the weak pull-up is internally enabled, but not reported here.

## REGISTER 11-7: ODCONA: PORTA OPEN-DRAIN CONTROL REGISTER

U-0	U-0	R/W-0/0	R/W-0/0	U-0	R/W-0/0	R/W-0/0	R/W-0/0
—	—	ODA<5:4>		—	ODA<2:0>		
bit 7							bit 0

### Legend:

R = Readable bit	W = Writable bit	
u = Bit is unchanged	x = Bit is unknown	U = Unimplemented bit, read as '0'
'1' = Bit is set	'0' = Bit is cleared	-n/n = Value at POR and BOR/Value at all other Resets

- bit 7-6      **Unimplemented:** Read as '0'
- bit 5-4      **ODA<5:4>:** PORTA Open-Drain Enable bits  
For RA<5:4> Pins, Respectively:  
                   1 = Port pin operates as open-drain drive (sink current only)  
                   0 = Port pin operates as standard push-pull drive (source and sink current)
- bit 3         **Unimplemented:** Read as '0'
- bit 2-0      **ODA<2:0>:** PORTA Open-Drain Enable bits  
For RA<2:0> Pins, Respectively:  
                   1 = Port pin operates as open-drain drive (sink current only)  
                   0 = Port pin operates as standard push-pull drive (source and sink current)

# PIC12(L)F1571/2

## REGISTER 11-8: SLRCONA: PORTA SLEW RATE CONTROL REGISTER

U-0	U-0	R/W-1/1	R/W-1/1	U-0	R/W-1/1	R/W-1/1	R/W-1/1
—	—	SLRA<5:4>		—	SLRA<2:0>		
bit 7							bit 0

### Legend:

R = Readable bit                      W = Writable bit  
u = Bit is unchanged                  x = Bit is unknown                  U = Unimplemented bit, read as '0'  
'1' = Bit is set                          '0' = Bit is cleared                  -n/n = Value at POR and BOR/Value at all other Resets

- bit 7-6            **Unimplemented:** Read as '0'
- bit 5-4            **SLRA<5:4>:** PORTA Slew Rate Enable bits  
For RA<5:4> Pins, Respectively:  
1 = Port pin slew rate is limited  
0 = Port pin slews at maximum rate
- bit 3              **Unimplemented:** Read as '0'
- bit 2-0            **SLRA<2:0>:** PORTA Slew Rate Enable bits  
For RA<2:0> Pins, Respectively:  
1 = Port pin slew rate is limited  
0 = Port pin slews at maximum rate

## REGISTER 11-9: INLVLA: PORTA INPUT LEVEL CONTROL REGISTER

U-0	U-0	R/W-0/0	R/W-0/0	R/W-0/0	R/W-0/0	R/W-0/0	R/W-0/0
—	—	INLVLA5	INLVLA4	INLVLA3	INLVLA2	INLVLA1	INLVLA0
bit 7							bit 0

### Legend:

R = Readable bit                      W = Writable bit  
u = Bit is unchanged                  x = Bit is unknown                  U = Unimplemented bit, read as '0'  
'1' = Bit is set                          '0' = Bit is cleared                  -n/n = Value at POR and BOR/Value at all other Resets

- bit 7-6            **Unimplemented:** Read as '0'
- bit 5-0            **INLVLA<5:0>:** PORTA Input Level Select bits  
For RA<5:0> Pins, Respectively:  
1 = ST input is used for PORT reads and Interrupt-On-Change  
0 = TTL input is used for PORT reads and Interrupt-On-Change

**TABLE 11-3: SUMMARY OF REGISTERS ASSOCIATED WITH PORTA**

Name	Bit 7	Bit 6	Bit 5	Bit 4	Bit 3	Bit 2	Bit 1	Bit 0	Register on Page
ANSELA	—	—	—	ANSA4	—	ANSA<2:0>			114
APFCON	RXDTSSEL	CWGASEL	CWGBSEL	—	T1GSEL	TXCKSEL	P2SEL	P1SEL	110
INLVLA	—	—	INLVLA<5:0>						116
LATA	—	—	LATA<5:4>		—	LATA<2:0>			114
ODCONA	—	—	ODA<5:4>		—	ODA<2:0>			115
OPTION_REG	WPUEN	INTEDG	TMR0CS	TMR0SE	PSA	PS<2:0>			157
PORTA	—	—	RA<5:0>						113
SLRCONA	—	—	SLRA<5:4>		—	SLRA<2:0>			116
TRISA	—	—	TRISA<5:4>		— <sup>(1)</sup>	TRISA<2:0>			113
WPUA	—	—	WPUA<5:0>						115

**Legend:** — = unimplemented location, read as '0'. Shaded cells are not used by PORTA.

**Note 1:** Unimplemented, read as '1'.

**TABLE 11-4: SUMMARY OF CONFIGURATION WORD WITH PORTA**

Name	Bits	Bit -/7	Bit -/6	Bit 13/5	Bit 12/4	Bit 11/3	Bit 10/2	Bit 9/1	Bit 8/0	Register on Page
CONFIG1	13:8	—	—	FCMEN	IESO	CLKOUTEN	BOREN<1:0>		—	42
	7:0	CP	MCLRE	PWRTE	WDTE<1:0>		FOSC<2:0>			

**Legend:** — = unimplemented location, read as '0'. Shaded cells are not used by PORTA.

# PIC12(L)F1571/2

---

NOTES:

## 12.0 INTERRUPT-ON-CHANGE

The PORTA and PORTB pins can be configured to operate as Interrupt-On-Change (IOC) pins. An interrupt can be generated by detecting a signal that has either a rising edge or a falling edge. Any individual port pin, or combination of port pins, can be configured to generate an interrupt. The Interrupt-On-Change module has the following features:

- Interrupt-On-Change enable (Master Switch)
- Individual pin configuration
- Rising and falling edge detection
- Individual pin interrupt flags

Figure 12-1 is a block diagram of the IOC module.

### 12.1 Enabling the Module

To allow individual port pins to generate an interrupt, the IOCIE bit of the INTCON register must be set. If the IOCIE bit is disabled, the edge detection on the pin will still occur, but an interrupt will not be generated.

### 12.2 Individual Pin Configuration

For each port pin, a rising edge detector and a falling edge detector are present. To enable a pin to detect a rising edge, the associated bit of the IOCxP register is set. To enable a pin to detect a falling edge, the associated bit of the IOCxN register is set.

A pin can be configured to detect rising and falling edges simultaneously by setting both associated bits of the IOCxP and IOCxN registers, respectively.

## 12.3 Interrupt Flags

The IOCAFx and IOCxBFx bits located in the IOCAF and IOCxBF registers, respectively, are status flags that correspond to the Interrupt-On-Change pins of the associated port. If an expected edge is detected on an appropriately enabled pin, then the status flag for that pin will be set, and an interrupt will be generated if the IOCIE bit is set. The IOCIF bit of the INTCON register reflects the status of all IOCAFx and IOCxBFx bits.

## 12.4 Clearing Interrupt Flags

The individual status flags, (IOCAFx and IOCxBFx bits), can be cleared by resetting them to zero. If another edge is detected during this clearing operation, the associated status flag will be set at the end of the sequence, regardless of the value actually being written.

In order to ensure that no detected edge is lost while clearing flags, only AND operations masking out known changed bits should be performed. The following sequence is an example of what should be performed.

### EXAMPLE 12-1: CLEARING INTERRUPT FLAGS (PORTA EXAMPLE)

```
MOVLW 0xff
XORWF IOCAF, W
ANDWF IOCAF, F
```

## 12.5 Operation in Sleep

The Interrupt-On-Change interrupt sequence will wake the device from Sleep mode, if the IOCIE bit is set.

If an edge is detected while in Sleep mode, the IOCxF register will be updated prior to the first instruction executed out of Sleep.

# PIC12(L)F1571/2

FIGURE 12-1: INTERRUPT-ON-CHANGE BLOCK DIAGRAM (PORTA EXAMPLE)

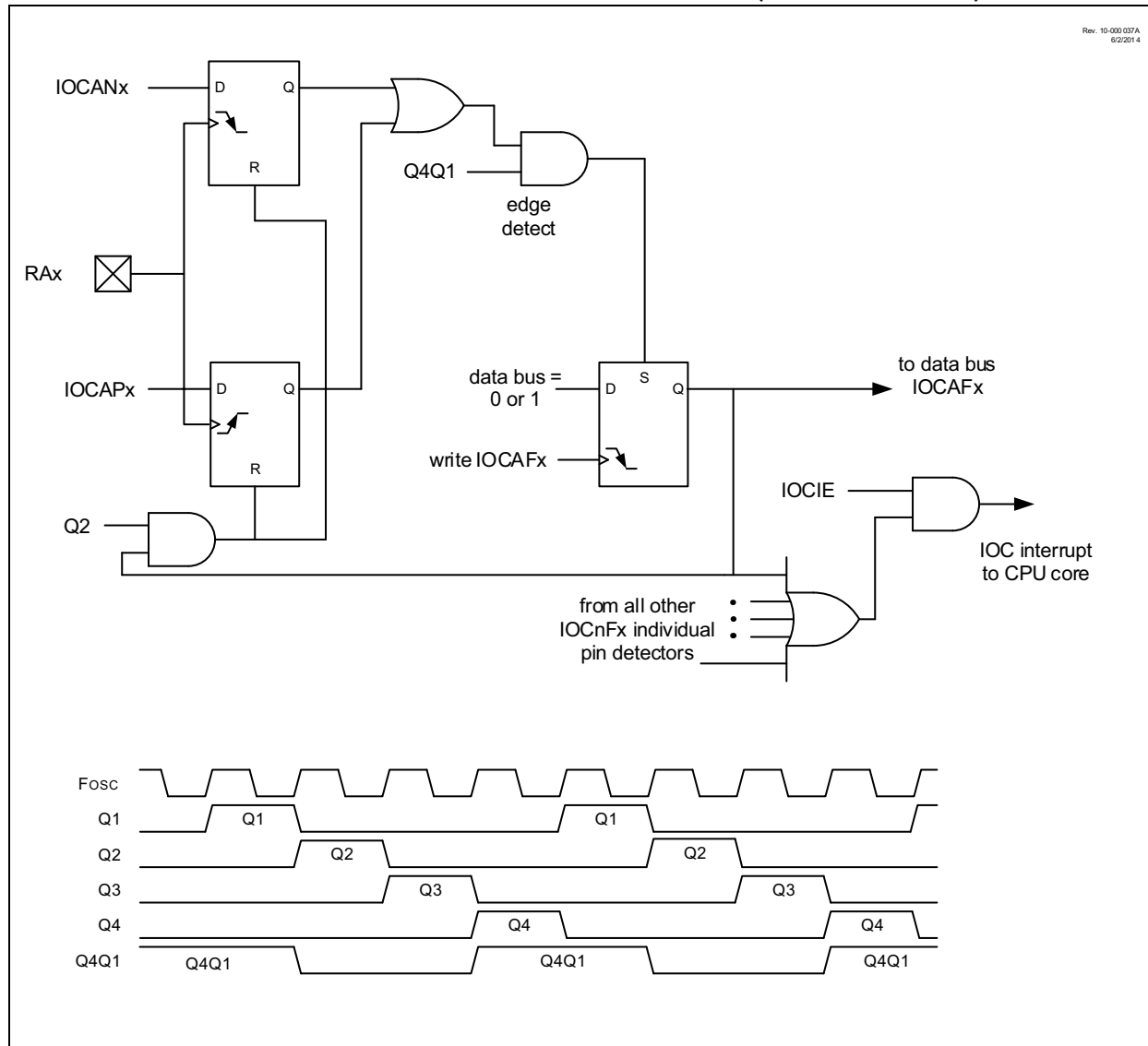



## 12.6 Register Definitions: Interrupt-On-Change Control

### REGISTER 12-1: IOCAP: INTERRUPT-ON-CHANGE PORTA POSITIVE EDGE REGISTER

U-0	U-0	R/W-0/0	R/W-0/0	R/W-0/0	R/W-0/0	R/W-0/0	R/W-0/0
—	—	IOCAP<5:0>					
bit 7							bit 0

#### Legend:

R = Readable bit

W = Writable bit

u = Bit is unchanged

x = Bit is unknown

U = Unimplemented bit, read as '0'

'1' = Bit is set

'0' = Bit is cleared

-n/n = Value at POR and BOR/Value at all other Resets

bit 7-6 **Unimplemented:** Read as '0'

bit 5-0 **IOCAP<5:0>**: Interrupt-On-Change PORTA Positive Edge Enable bits

1 = Interrupt-On-Change is enabled on the pin for a positive going edge; IOCAF<sub>x</sub> bit and IOCIF flag will be set upon detecting an edge

0 = Interrupt-On-Change is disabled for the associated pin

### REGISTER 12-2: IOCAN: INTERRUPT-ON-CHANGE PORTA NEGATIVE EDGE REGISTER

U-0	U-0	R/W-0/0	R/W-0/0	R/W-0/0	R/W-0/0	R/W-0/0	R/W-0/0
—	—	IOCAN<5:0>					
bit 7							bit 0

#### Legend:

R = Readable bit

W = Writable bit

u = Bit is unchanged

x = Bit is unknown

U = Unimplemented bit, read as '0'

'1' = Bit is set

'0' = Bit is cleared

-n/n = Value at POR and BOR/Value at all other Resets

bit 7-6 **Unimplemented:** Read as '0'

bit 5-0 **IOCAN<5:0>**: Interrupt-On-Change PORTA Negative Edge Enable bits

1 = Interrupt-On-Change is enabled on the pin for a negative going edge; IOCAF<sub>x</sub> bit and IOCIF flag will be set upon detecting an edge.

0 = Interrupt-On-Change is disabled for the associated pin

# PIC12(L)F1571/2

## REGISTER 12-3: IOCAF: INTERRUPT-ON-CHANGE PORTA FLAG REGISTER

U-0	U-0	R/W/HS-0/0	R/W/HS-0/0	R/W/HS-0/0	R/W/HS-0/0	R/W/HS-0/0	R/W/HS-0/0
—	—	IOCAF<5:0>					
bit 7							bit 0

### Legend:

R = Readable bit	W = Writable bit	U = Unimplemented bit, read as '0'
u = Bit is unchanged	x = Bit is unknown	-n/n = Value at POR and BOR/Value at all other Resets
'1' = Bit is set	'0' = Bit is cleared	HS - Bit is set in hardware

bit 7-6 **Unimplemented:** Read as '0'

bit 5-0 **IOCAF<5:0>:** Interrupt-On-Change PORTA Flag bits

1 = An enabled change was detected on the associated pin

Set when IOCAPx = 1 and a rising edge was detected on RAX, or when IOCANx = 1 and a falling edge was detected on RAX.

0 = No change was detected or the user cleared the detected change

**TABLE 12-1: SUMMARY OF REGISTERS ASSOCIATED WITH INTERRUPT-ON-CHANGE**

Name	Bit 7	Bit 6	Bit 5	Bit 4	Bit 3	Bit 2	Bit 1	Bit 0	Register on Page
ANSELA	—	—	—	ANSA4	—	ANSA<2:0>			114
INTCON	GIE	PEIE	TMR0IE	INTE	IOCIE	TMR0IF	INTF	IOCIF	74
IOCAF	—	—	IOCAF<5:0>						122
IOCAN	—	—	IOCAN<5:0>						121
IOCAP	—	—	IOCAP<5:0>						121
TRISA	—	—	TRISA<5:4>	— <sup>(1)</sup>	TRISA<2:0>			113	

**Legend:** — = unimplemented location, read as '0'. Shaded cells are not used by Interrupt-On-Change.

**Note 1:** Unimplemented, read as '1'.

## 13.0 FIXED VOLTAGE REFERENCE (FVR)

The Fixed Voltage Reference (FVR) is a stable voltage reference, independent of  $V_{DD}$ , with a nominal output level ( $V_{FVR}$ ) of 1.024V. The output of the FVR can be configured to supply a reference voltage to the following:

- ADC input channel
- Comparator positive input
- Comparator negative input

The FVR can be enabled by setting the FVREN bit of the FVRCON register.

### 13.1 Independent Gain Amplifier

The output of the FVR supplied to the peripherals, (listed above), is routed through a programmable gain amplifier. Each amplifier can be programmed for a gain of 1x, 2x or 4x, to produce the three possible voltage levels.

The ADFVR<1:0> bits of the FVRCON register are used to enable and configure the gain amplifier settings for the reference supplied to the ADC module. Reference [Section 15.0 “Analog-to-Digital Converter \(ADC\) Module”](#) for additional information.

The CDAFVR<1:0> bits of the FVRCON register are used to enable and configure the gain amplifier settings for the reference supplied to the comparator modules. Reference [Section 17.0 “Comparator Module”](#) for additional information.

To minimize current consumption when the FVR is disabled, the FVR buffers should be turned off by clearing the Buffer Gain Selection bits.

### 13.2 FVR Stabilization Period

The FVR can be enabled by setting the FVREN bit of the FVRCON register.

When the Fixed Voltage Reference module is enabled, it requires time for the reference and amplifier circuits to stabilize. Once the circuits stabilize and are ready for use, the FVRRDY bit of the FVRCON register will be set. See the FVR Stabilization Period characterization graph, [Figure 27-21](#).

**FIGURE 13-1: VOLTAGE REFERENCE BLOCK DIAGRAM**

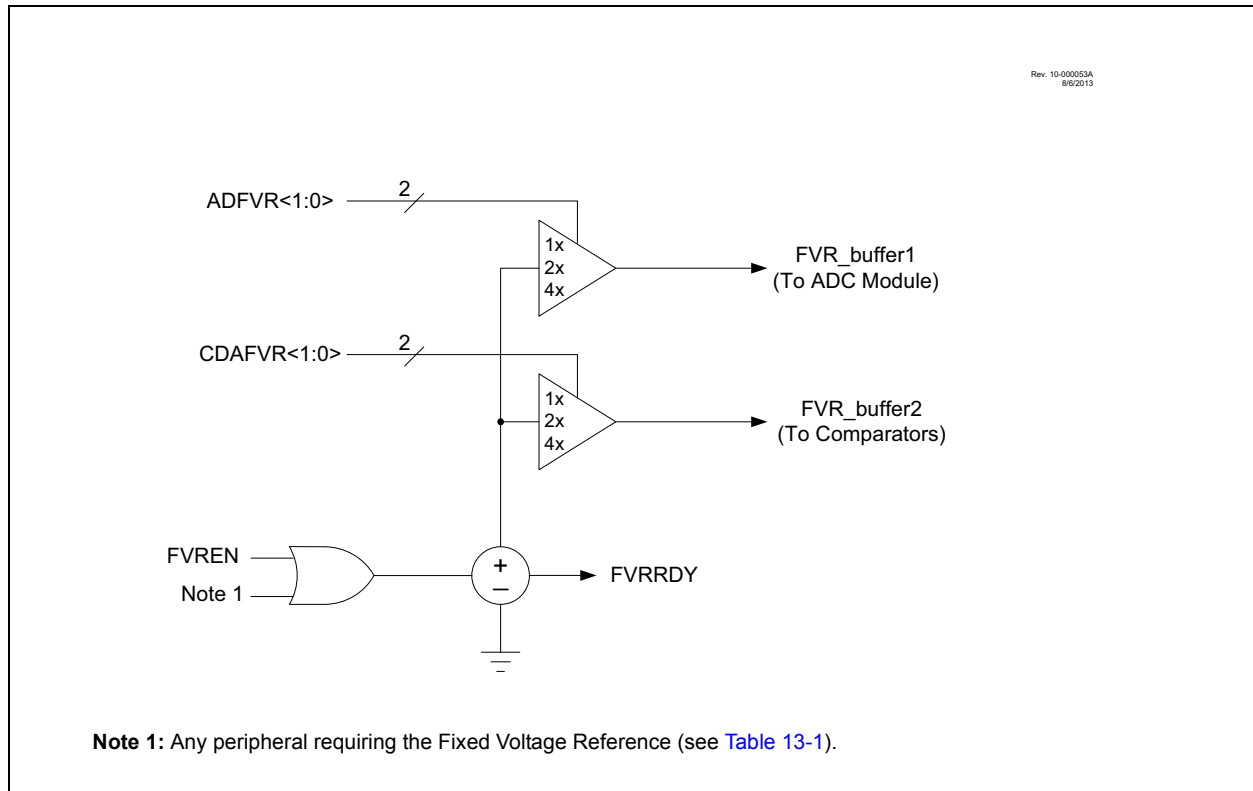

# PIC12(L)F1571/2

---

---

**TABLE 13-1: PERIPHERALS REQUIRING THE FIXED VOLTAGE REFERENCE (FVR)**

Peripheral	Conditions	Description
HFINTOSC	FOSC<2:0> = 010 and IRCF<3:0> = 000x	INTOSC is active and device is not in Sleep.
BOR	BOREN<1:0> = 11	BOR is always enabled.
	BOREN<1:0> = 10 and BORFS = 1	BOR is disabled in Sleep mode, BOR Fast Start is enabled.
	BOREN<1:0> = 01 and BORFS = 1	BOR under software control, BOR Fast Start is enabled.
LDO	All PIC12F1571/2 devices, when VREGPM = 1 and not in Sleep	The device runs off of the Low-Power Regulator when in Sleep mode.

## 13.3 Register Definitions: FVR Control

**REGISTER 13-1: FVRCON: FIXED VOLTAGE REFERENCE CONTROL REGISTER**

R/W-0/0	R-q/q	R/W-0/0	R/W-0/0	R/W-0/0	R/W-0/0	R/W-0/0	R/W-0/0
FVREN <sup>(1)</sup>	FVRRDY <sup>(2)</sup>	TSEN <sup>(3)</sup>	TSRNG <sup>(3)</sup>	CDAFVR<1:0> <sup>(1)</sup>		ADFVR<1:0> <sup>(1)</sup>	
bit 7							bit 0

**Legend:**

R = Readable bit	W = Writable bit	U = Unimplemented bit, read as '0'
u = Bit is unchanged	x = Bit is unknown	-n/n = Value at POR and BOR/Value at all other Resets
'1' = Bit is set	'0' = Bit is cleared	q = Value depends on condition

- bit 7      **FVREN:** Fixed Voltage Reference Enable bit<sup>(1)</sup>  
 1 = Fixed Voltage Reference is enabled  
 0 = Fixed Voltage Reference is disabled
- bit 6      **FVRRDY:** Fixed Voltage Reference Ready Flag bit<sup>(2)</sup>  
 1 = Fixed Voltage Reference output is ready for use  
 0 = Fixed Voltage Reference output is not ready or not enabled
- bit 5      **TSEN:** Temperature Indicator Enable bit<sup>(3)</sup>  
 1 = Temperature indicator is enabled  
 0 = Temperature indicator is disabled
- bit 4      **TSRNG:** Temperature Indicator Range Selection bit<sup>(3)</sup>  
 1 = VOUT = VDD – 4VT (High Range)  
 0 = VOUT = VDD – 2VT (Low Range)
- bit 3-2    **CDAFVR<1:0>:** Comparator FVR Buffer Gain Selection bits<sup>(1)</sup>  
 11 = Comparator FVR Buffer Gain is 4x, with output VCDAFVR = 4x VFVR<sup>(4)</sup>  
 10 = Comparator FVR Buffer Gain is 2x, with output VCDAFVR = 2x VFVR<sup>(4)</sup>  
 01 = Comparator FVR Buffer Gain is 1x, with output VCDAFVR = 1x VFVR  
 00 = Comparator FVR Buffer is off
- bit 1-0    **ADFVR<1:0>:** ADC FVR Buffer Gain Selection bit<sup>(1)</sup>  
 11 = ADC FVR Buffer Gain is 4x, with output VADFVR = 4x VFVR<sup>(4)</sup>  
 10 = ADC FVR Buffer Gain is 2x, with output VADFVR = 2x VFVR<sup>(4)</sup>  
 01 = ADC FVR Buffer Gain is 1x, with output VADFVR = 1x VFVR  
 00 = ADC FVR Buffer is off

- Note 1:** To minimize current consumption when the FVR is disabled, the FVR buffers should be turned off by clearing the Buffer Gain Selection bits.
- 2:** FVRRDY is always '1' for the PIC12F1571/2 devices.
- 3:** See [Section 14.0 "Temperature Indicator Module"](#) for additional information.
- 4:** Fixed Voltage Reference output cannot exceed VDD.

**TABLE 13-2: SUMMARY OF REGISTERS ASSOCIATED WITH THE FIXED VOLTAGE REFERENCE**

Name	Bit 7	Bit 6	Bit 5	Bit 4	Bit 3	Bit 2	Bit 1	Bit 0	Register on Page
FVRCON	FVREN	FVRRDY	TSEN	TSRNG	CDAFVR>1:0>		ADFVR<1:0>		<a href="#">125</a>

# PIC12(L)F1571/2

---

NOTES:

## 14.0 TEMPERATURE INDICATOR MODULE

This family of devices is equipped with a temperature circuit designed to measure the operating temperature of the silicon die. The circuit's range of operating temperature falls between -40°C and +85°C. The output is a voltage that is proportional to the device temperature. The output of the temperature indicator is internally connected to the device ADC.

The circuit may be used as a temperature threshold detector or a more accurate temperature indicator, depending on the level of calibration performed. A one-point calibration allows the circuit to indicate a temperature closely surrounding that point. A two-point calibration allows the circuit to sense the entire range of temperature more accurately. Reference Application Note AN1333, "Use and Calibration of the Internal Temperature Indicator" (DS00001333) for more details regarding the calibration process.

### 14.1 Circuit Operation

Figure 14-1 shows a simplified block diagram of the temperature circuit. The proportional voltage output is achieved by measuring the forward voltage drop across multiple silicon junctions.

Equation 14-1 describes the output characteristics of the temperature indicator.

#### EQUATION 14-1: V<sub>OUT</sub> RANGES

High Range:  $V_{OUT} = V_{DD} - 4 V_T$

Low Range:  $V_{OUT} = V_{DD} - 2 V_T$

The temperature sense circuit is integrated with the Fixed Voltage Reference (FVR) module. See Section 13.0 "Fixed Voltage Reference (FVR)" for more information.

The circuit is enabled by setting the TSEN bit of the FVRCON register. When disabled, the circuit draws no current.

The circuit operates in either high or low range. The high range, selected by setting the TSRNG bit of the FVRCON register, provides a wider output voltage. This provides more resolution over the temperature range, but may be less consistent from part to part. This range requires a higher bias voltage to operate and thus, a higher V<sub>DD</sub> is needed.

The low range is selected by clearing the TSRNG bit of the FVRCON register. The low range generates a lower voltage drop and thus, a lower bias voltage is needed to operate the circuit. The low range is provided for low-voltage operation.

FIGURE 14-1: TEMPERATURE CIRCUIT DIAGRAM

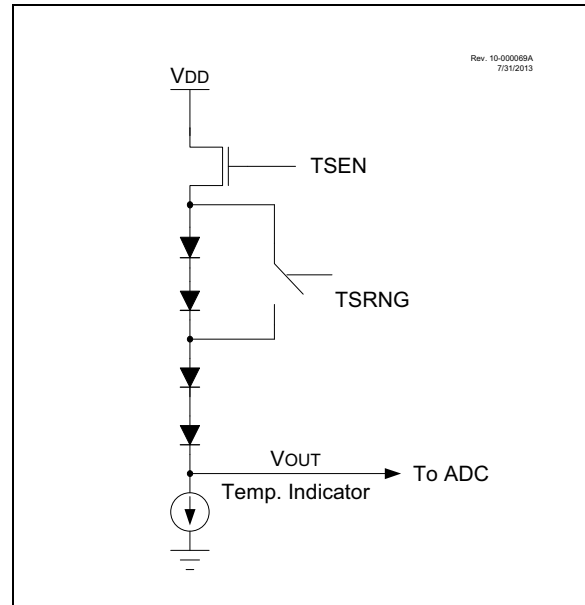

### 14.2 Minimum Operating V<sub>DD</sub>

When the temperature circuit is operated in low range, the device may be operated at any operating voltage that is within specifications.

When the temperature circuit is operated in high range, the device operating voltage, V<sub>DD</sub>, must be high enough to ensure that the temperature circuit is correctly biased.

Table 14-1 shows the recommended minimum V<sub>DD</sub> vs. range setting.

TABLE 14-1: RECOMMENDED V<sub>DD</sub> VS. RANGE

Min. V <sub>DD</sub> , TSRNG = 1	Min. V <sub>DD</sub> , TSRNG = 0
3.6V	1.8V

### 14.3 Temperature Output

The output of the circuit is measured using the internal Analog-to-Digital Converter. A channel is reserved for the temperature circuit output. Refer to Section 15.0 "Analog-to-Digital Converter (ADC) Module" for detailed information.

### 14.4 ADC Acquisition Time

To ensure accurate temperature measurements, the user must wait at least 200 μs after the ADC input multiplexer is connected to the temperature indicator output before the conversion is performed. In addition, the user must wait 200 μs between sequential conversions of the temperature indicator output.

# PIC12(L)F1571/2

---

---

**TABLE 14-2: SUMMARY OF REGISTERS ASSOCIATED WITH THE TEMPERATURE INDICATOR**

Name	Bit 7	Bit 6	Bit 5	Bit 4	Bit 3	Bit 2	Bit 1	Bit 0	Register on Page
FVRCON	FVREN	FVRRDY	TSEN	TSRNG	CDAFVR<1:0>		ADFVR<1:0>		<a href="#">118</a>

**Legend:** Shaded cells are unused by the temperature indicator module.



## 15.0 ANALOG-TO-DIGITAL CONVERTER (ADC) MODULE

The Analog-to-Digital Converter (ADC) allows conversion of an analog input signal to a 10-bit binary representation of that signal. This device uses analog inputs, which are multiplexed into a single sample and hold circuit. The output of the sample and hold is connected to the input of the converter. The converter generates a 10-bit binary result via successive approximation and stores the conversion result into the ADC result registers (ADRESH:ADRESL register pair). Figure 15-1 shows the block diagram of the ADC.

The ADC voltage reference is software selectable to be either internally generated or externally supplied.

The ADC can generate an interrupt upon completion of a conversion. This interrupt can be used to wake-up the device from Sleep.

**FIGURE 15-1: ADC BLOCK DIAGRAM**

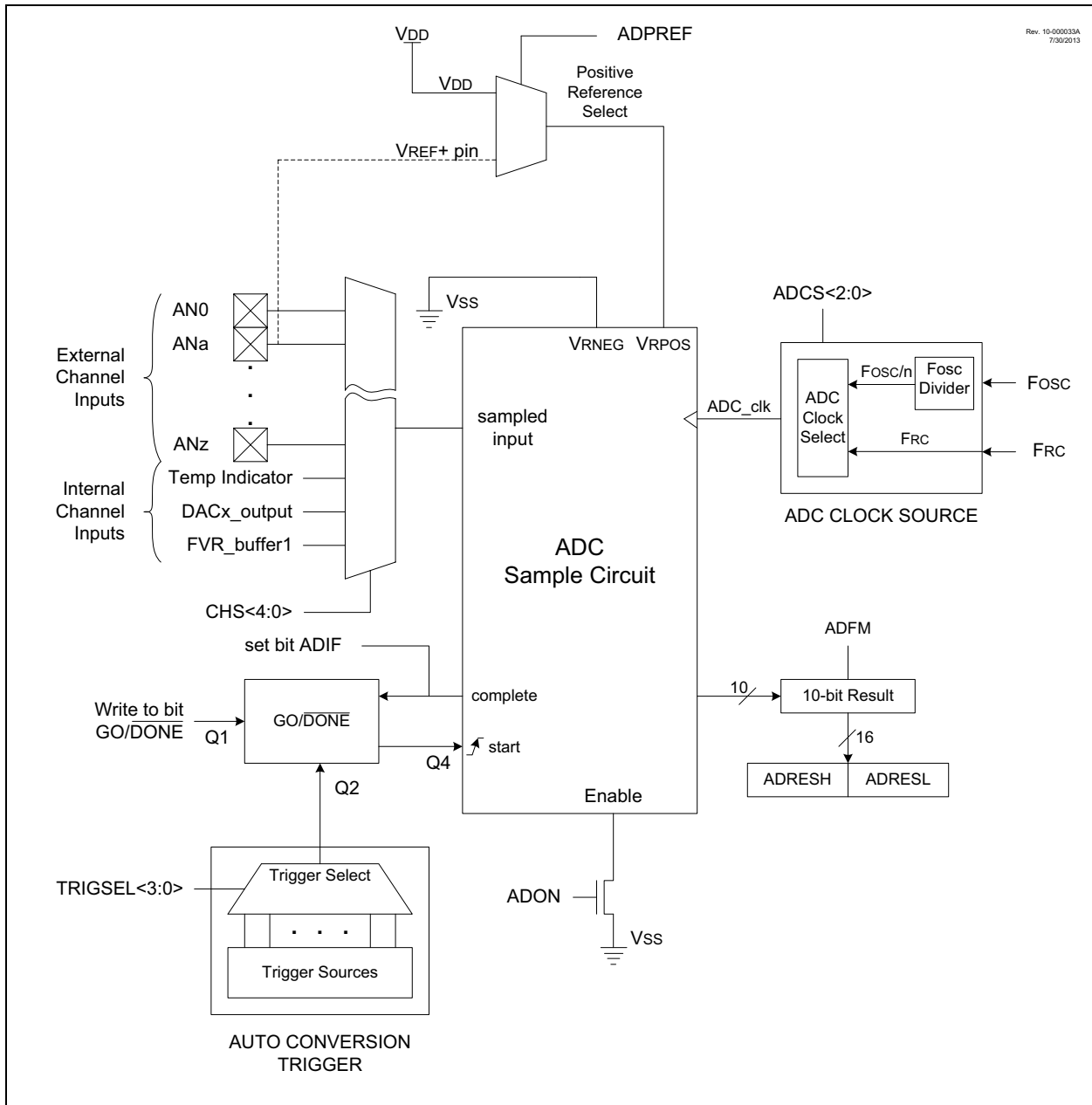

# PIC12(L)F1571/2

## 15.1 ADC Configuration

When configuring and using the ADC the following functions must be considered:

- Port configuration
- Channel selection
- ADC voltage reference selection
- ADC conversion clock source
- Interrupt control
- Result formatting

### 15.1.1 PORT CONFIGURATION

The ADC can be used to convert both analog and digital signals. When converting analog signals, the I/O pin should be configured for analog by setting the associated TRISx and ANSELx bits. Refer to [Section 11.0 “I/O Ports”](#) for more information.

**Note:** Analog voltages on any pin that is defined as a digital input may cause the input buffer to conduct excess current.

### 15.1.2 CHANNEL SELECTION

There are 7 channel selections available:

- AN<3:0> pins
- Temperature Indicator
- DAC1\_output
- FVR\_buffer1

The CHS bits of the ADCON0 register determine which channel is connected to the sample and hold circuit.

When changing channels, a delay (TACQ) is required before starting the next conversion. Refer to [Section 15.2.6 “ADC Conversion Procedure”](#) for more information.

### 15.1.3 ADC VOLTAGE REFERENCE

The ADC module uses a positive and a negative voltage reference. The positive reference is labeled ref+ and the negative reference is labeled ref-.

The positive voltage reference (ref+) is selected by the ADPREFx bits in the ADCON1 register. The positive voltage reference source can be:

- VREF+ pin
- VDD

The negative voltage reference (ref-) source is:

- Vss

### 15.1.4 CONVERSION CLOCK

The source of the conversion clock is software-selectable via the ADCSx bits of the ADCON1 register. There are seven possible clock options:

- Fosc/2
- Fosc/4
- Fosc/8
- Fosc/16
- Fosc/32
- Fosc/64
- FRC (internal Fast RC oscillator)

The time to complete one bit conversion is defined as TAD. One full 10-bit conversion requires 11.5 TAD periods, as shown in [Figure 15-2](#).

For correct conversion, the appropriate TAD specification must be met. Refer to the ADC conversion requirements in [Section 26.0 “Electrical Specifications”](#) for more information. [Table 15-1](#) gives examples of appropriate ADC clock selections.

**Note:** Unless using the FRC, any changes in the system clock frequency will change the ADC clock frequency, which may adversely affect the ADC result.

**TABLE 15-1: ADC CLOCK PERIOD (TAD) VS. DEVICE OPERATING FREQUENCIES**

ADC Clock Period (TAD)		Device Frequency (Fosc)				
ADC Clock Source	ADCS<2:0>	20 MHz	16 MHz	8 MHz	4 MHz	1 MHz
Fosc/2	000	100 ns	125 ns	250 ns	500 ns	2.0 μs
Fosc/4	100	200 ns	250 ns	500 ns	1.0 μs	4.0 μs
Fosc/8	001	400 ns	500 ns	1.0 μs	2.0 μs	8.0 μs
Fosc/16	101	800 ns	1.0 μs	2.0 μs	4.0 μs	16.0 μs
Fosc/32	010	1.6 μs	2.0 μs	4.0 μs	8.0 μs	32.0 μs
Fosc/64	110	3.2 μs	4.0 μs	8.0 μs	16.0 μs	64.0 μs
FRC	x11	1.0-6.0 μs	1.0-6.0 μs	1.0-6.0 μs	1.0-6.0 μs	1.0-6.0 μs

**Legend:** Shaded cells are outside of recommended range.

**Note:** The TAD period when using the FRC clock source can fall within a specified range (see TAD parameter). The TAD period when using the Fosc-based clock source can be configured for a more precise TAD period. However, the FRC clock source must be used when conversions are to be performed with the device in Sleep mode.

**FIGURE 15-2: ANALOG-TO-DIGITAL CONVERSION TAD CYCLES**

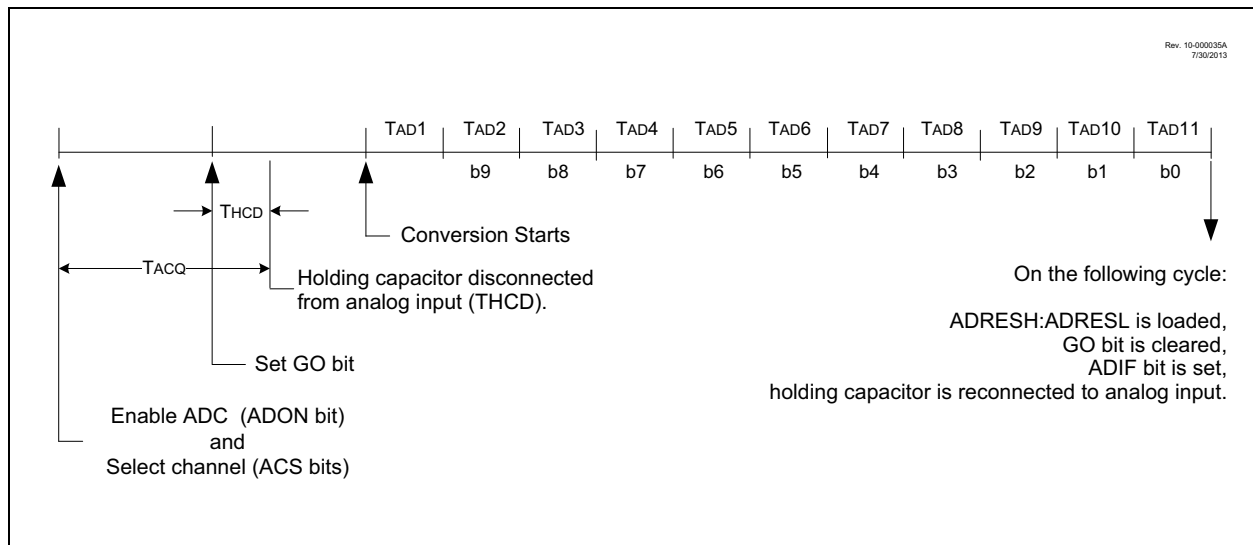

# PIC12(L)F1571/2

## 15.1.5 INTERRUPTS

The ADC module allows for the ability to generate an interrupt upon completion of an Analog-to-Digital conversion. The ADC Interrupt Flag is the ADIF bit in the PIR1 register. The ADC Interrupt Enable is the ADIE bit in the PIE1 register. The ADIF bit must be cleared in software.

- Note 1:** The ADIF bit is set at the completion of every conversion, regardless of whether or not the ADC interrupt is enabled.
- 2:** The ADC operates during Sleep only when the FRC oscillator is selected.

This interrupt can be generated while the device is operating or while in Sleep. If the device is in Sleep, the interrupt will wake-up the device. Upon waking from Sleep, the next instruction following the SLEEP instruction is always executed. If the user is attempting to wake-up from Sleep and resume in-line code execution, the ADIE bit of the PIE1 register and the PEIE bit of the INTCON register must both be set, and the GIE bit of the INTCON register must be cleared. If all three of these bits are set, the execution will switch to the Interrupt Service Routine.

## 15.1.6 RESULT FORMATTING

The 10-bit ADC conversion result can be supplied in two formats, left justified or right justified. The ADFM bit of the ADCON1 register controls the output format.

Figure 15-3 shows the two output formats.

**FIGURE 15-3: 10-BIT ADC CONVERSION RESULT FORMAT**

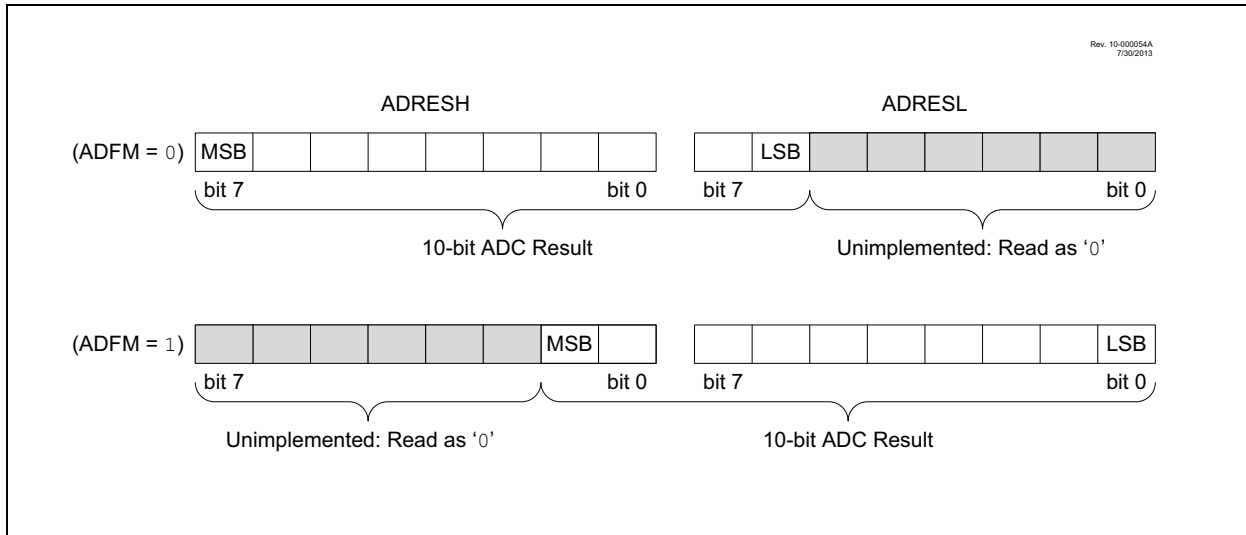

## 15.2 ADC Operation

### 15.2.1 STARTING A CONVERSION

To enable the ADC module, the ADON bit of the ADCON0 register must be set to a '1'. Setting the GO/DONE bit of the ADCON0 register to a '1' will start the Analog-to-Digital conversion.

**Note:** The GO/DONE bit should not be set in the same instruction that turns on the ADC. Refer to [Section 15.2.6 “ADC Conversion Procedure”](#).

### 15.2.2 COMPLETION OF A CONVERSION

When the conversion is complete, the ADC module will:

- Clear the GO/DONE bit
- Set the ADIF Interrupt Flag bit
- Update the ADRESH and ADRESL registers with new conversion result

### 15.2.3 TERMINATING A CONVERSION

If a conversion must be terminated before completion, the GO/DONE bit can be cleared in software. The ADRESH and ADRESL registers will be updated with the partially complete Analog-to-Digital conversion sample. Incomplete bits will match the last bit converted.

**Note:** A device Reset forces all registers to their Reset state. Thus, the ADC module is turned off and any pending conversion is terminated.

### 15.2.4 ADC OPERATION DURING SLEEP

The ADC module can operate during Sleep. This requires the ADC clock source to be set to the FRC option. Performing the ADC conversion during Sleep can reduce system noise. If the ADC interrupt is enabled, the device will wake-up from Sleep when the conversion completes. If the ADC interrupt is disabled, the ADC module is turned off after the conversion completes, although the ADON bit remains set.

When the ADC clock source is something other than FRC, a SLEEP instruction causes the present conversion to be aborted and the ADC module is turned off, although the ADON bit remains set.

### 15.2.5 AUTO-CONVERSION TRIGGER

The auto-conversion trigger allows periodic ADC measurements without software intervention. When a rising edge of the selected source occurs, the GO/DONE bit is set by hardware.

The auto-conversion trigger source is selected with the TRIGSEL<3:0> bits of the ADCON2 register.

Using the auto-conversion trigger does not assure proper ADC timing. It is the user's responsibility to ensure that the ADC timing requirements are met.

The PWM module can trigger the ADC in two ways, directly through the PWMx\_OFx\_match or through the interrupts generated by all four match signals. See [Section 22.0 “16-Bit Pulse-Width Modulation \(PWM\) Module”](#). If the interrupts are chosen, each enabled interrupt in PWMxINTE will trigger a conversion. Refer to [Figure 15-4](#) for more information.

See [Table 15-2](#) for auto-conversion sources.

**FIGURE 15-4: 16-BIT PWM INTERRUPT BLOCK DIAGRAM**

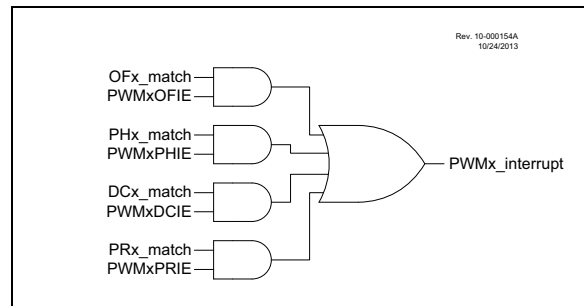

**TABLE 15-2: AUTO-CONVERSION SOURCES**

Source Peripheral	Signal Name
Timer0	T0_overflow
Timer1	T1_overflow
Timer2	T2_match
Comparator C1	C1OUT_sync
PWM1	PWM1_OF_match
PWM1	PWM1_interrupt
PWM2	PWM2_OF_match
PWM2	PWM2_interrupt
PWM3	PWM3_OF_match
PWM3	PWM3_interrupt

# PIC12(L)F1571/2

## 15.2.6 ADC CONVERSION PROCEDURE

This is an example procedure for using the ADC to perform an Analog-to-Digital conversion:

1. Configure port:
  - Disable pin output driver (refer to the TRISx register)
  - Configure pin as analog (refer to the ANSELx register)
  - Disable weak pull-ups either globally (refer to the OPTION\_REG register) or individually (refer to the appropriate WPUx register)
2. Configure the ADC module:
  - Select ADC conversion clock
  - Configure voltage reference
  - Select ADC input channel
  - Turn on ADC module
3. Configure ADC interrupt (optional):
  - Clear ADC interrupt flag
  - Enable ADC interrupt
  - Enable peripheral interrupt
  - Enable global interrupt<sup>(1)</sup>
4. Wait the required acquisition time.<sup>(2)</sup>
5. Start conversion by setting the GO/DONE bit.
6. Wait for ADC conversion to complete by one of the following:
  - Polling the GO/DONE bit
  - Waiting for the ADC interrupt (interrupts enabled)
7. Read ADC result.
8. Clear the ADC interrupt flag (required if interrupt is enabled).

**Note 1:** The global interrupt can be disabled if the user is attempting to wake-up from Sleep and resume in-line code execution.

**2:** Refer to [Section 15.4 “ADC Acquisition Requirements”](#).

## EXAMPLE 15-1: ADC CONVERSION

```
;This code block configures the ADC
;for polling, Vdd and Vss references, FRC
;oscillator and AN0 input.
;
;Conversion start & polling for completion
;are included.
;
BANKSEL    ADCON1    ;
MOVLW     B'11110000' ;Right justify, FRC
;oscillator
MOVWF     ADCON1    ;Vdd and Vss Vref+
BANKSEL    TRISA     ;
BSF       TRISA,0   ;Set RA0 to input
BANKSEL    ANSEL     ;
BSF       ANSEL,0   ;Set RA0 to analog
BANKSEL    WPUA     ;
BCF       WPUA,0    ;Disable weak
;pull-up on RA0
BANKSEL    ADCON0    ;
MOVLW     B'00000001' ;Select channel AN0
MOVWF     ADCON0    ;Turn ADC On
CALL      SampleTime ;Acquisition delay
BSF       ADCON0,ADGO ;Start conversion
BTFSC    ADCON0,ADGO ;Is conversion done?
GOTO     $-1        ;No, test again
BANKSEL    ADRESH    ;
MOVF     ADRESH,W   ;Read upper 2 bits
MOVWF    RESULTHI   ;store in GPR space
BANKSEL    ADRESL    ;
MOVF     ADRESL,W   ;Read lower 8 bits
MOVWF    RESULTLO   ;Store in GPR space
```

## 15.3 Register Definitions: ADC Control

**REGISTER 15-1: ADCON0: ADC CONTROL REGISTER 0**

U-0	R/W-0/0	R/W-0/0	R/W-0/0	R/W-0/0	R/W-0/0	R/W-0/0	R/W-0/0
—	CHS<4:0>					GO/DONE	ADON
bit 7							bit 0

**Legend:**

R = Readable bit	W = Writable bit	
u = Bit is unchanged	x = Bit is unknown	U = Unimplemented bit, read as '0'
'1' = Bit is set	'0' = Bit is cleared	-n/n = Value at POR and BOR/Value at all other Resets

bit 7      **Unimplemented:** Read as '0'

bit 6-2    **CHS<4:0>:** Analog Channel Select bits

- 00000 = AN0
- 00001 = AN1
- 00010 = AN2
- 00011 = AN3
- 00100 = Reserved; no channel connected
- 
- 
- 
- 11100 = Reserved; no channel connected
- 11101 = Temperature indicator<sup>(1)</sup>
- 11110 = DAC (Digital-to-Analog Converter)<sup>(2)</sup>
- 11111 = FVR (Fixed Voltage Reference) Buffer 1 output<sup>(3)</sup>

bit 1      **GO/DONE:** ADC Conversion Status bit

- 1 = ADC conversion cycle is in progress  
Setting this bit starts an ADC conversion cycle. This bit is automatically cleared by hardware when the ADC conversion has completed.
- 0 = ADC conversion completed/not in progress

bit 0      **ADON:** ADC Enable bit

- 1 = ADC is enabled
- 0 = ADC is disabled and consumes no operating current

- Note 1:** See [Section 14.0 “Temperature Indicator Module”](#) for more information.  
**Note 2:** See [Section 16.0 “5-Bit Digital-to-Analog Converter \(DAC\) Module”](#) for more information.  
**Note 3:** See [Section 13.0 “Fixed Voltage Reference \(FVR\)”](#) for more information.

# PIC12(L)F1571/2

## REGISTER 15-2: ADCON1: ADC CONTROL REGISTER 1

R/W-0/0	R/W-0/0	R/W-0/0	R/W-0/0	U-0	U-0	R/W-0/0	R/W-0/0
ADFM	ADCS<2:0>			—	—	ADPREF<1:0>	
bit 7							bit 0

### Legend:

R = Readable bit

W = Writable bit

u = Bit is unchanged

x = Bit is unknown

U = Unimplemented bit, read as '0'

'1' = Bit is set

'0' = Bit is cleared

-n/n = Value at POR and BOR/Value at all other Resets

- bit 7      **ADFM:** ADC Result Format Select bit  
1 = Right justified; six Most Significant bits of ADRESH are set to '0' when the conversion result is loaded  
0 = Left justified; six Least Significant bits of ADRESL are set to '0' when the conversion result is loaded
- bit 6-4    **ADCS<2:0>:** ADC Conversion Clock Select bits  
000 = Fosc/2  
001 = Fosc/8  
010 = Fosc/32  
011 = FRC (clock supplied from an internal RC oscillator)  
100 = Fosc/4  
101 = Fosc/16  
110 = Fosc/64  
111 = FRC (clock supplied from an internal RC oscillator)
- bit 3-2    **Unimplemented:** Read as '0'
- bit 1-0    **ADPREF<1:0>:** ADC Positive Voltage Reference Configuration bits  
00 = VRPOS is connected to VDD  
01 = Reserved  
10 = VRPOS is connected to external VREF+ pin<sup>(1)</sup>  
11 = VRPOS is connected to internal Fixed Voltage Reference (FVR)

**Note 1:** When selecting the VREF+ pin as the source of the positive reference, be aware that a minimum voltage specification exists. See [Section 26.0 "Electrical Specifications"](#) for details.



## REGISTER 15-3: ADCON2: ADC CONTROL REGISTER 2

R/W-0/0	R/W-0/0	R/W-0/0	R/W-0/0	U-0	U-0	U-0	U-0
TRIGSEL<3:0> <sup>(1)</sup>				—	—	—	—
bit 7				bit 0			

### Legend:

R = Readable bit

W = Writable bit

u = Bit is unchanged

x = Bit is unknown

U = Unimplemented bit, read as '0'

'1' = Bit is set

'0' = Bit is cleared

-n/n = Value at POR and BOR/Value at all other Resets

bit 7-4      **TRIGSEL<3:0>**: Auto-Conversion Trigger Selection bits<sup>(1)</sup>

0000 = No auto-conversion trigger selected  
 0001 = PWM1 – PWM1\_interrupt  
 0010 = PWM2 – PWM2\_interrupt  
 0011 = Timer0 – T0\_overflow<sup>(2)</sup>  
 0100 = Timer1 – T1\_overflow<sup>(2)</sup>  
 0101 = Timer2 – T2\_match  
 0110 = Comparator C1 – C1OUT\_sync  
 0111 = PWM3 – PWM3\_interrupt  
 1000 = PWM1 – PWM1\_OF1\_match  
 1001 = PWM2 – PWM2\_OF2\_match  
 1010 = PWM3 – PWM3\_OF3\_match  
 1011 = Reserved  
 1100 = Reserved  
 1101 = Reserved  
 1110 = Reserved  
 1111 = Reserved

bit 3-0      **Unimplemented**: Read as '0'

**Note 1:** This is a rising edge sensitive input for all sources.

**2:** Signal also sets its corresponding interrupt flag.

# PIC12(L)F1571/2

## REGISTER 15-4: ADRESH: ADC RESULT REGISTER HIGH (ADRESH) ADFM = 0

R/W-x/u	R/W-x/u	R/W-x/u	R/W-x/u	R/W-x/u	R/W-x/u	R/W-x/u	R/W-x/u
ADRES<9:2>							
bit 7							bit 0

**Legend:**

R = Readable bit	W = Writable bit	
u = Bit is unchanged	x = Bit is unknown	U = Unimplemented bit, read as '0'
'1' = Bit is set	'0' = Bit is cleared	-n/n = Value at POR and BOR/Value at all other Resets

bit 7-0      **ADRES<9:2>**: ADC Result Register bits  
Upper eight bits of 10-bit conversion result.

## REGISTER 15-5: ADRESL: ADC RESULT REGISTER LOW (ADRESL) ADFM = 0

R/W-x/u	R/W-x/u	R/W-x/u	R/W-x/u	R/W-x/u	R/W-x/u	R/W-x/u	R/W-x/u
ADRES<1:0>		—	—	—	—	—	—
bit 7							bit 0

**Legend:**

R = Readable bit	W = Writable bit	
u = Bit is unchanged	x = Bit is unknown	U = Unimplemented bit, read as '0'
'1' = Bit is set	'0' = Bit is cleared	-n/n = Value at POR and BOR/Value at all other Resets

bit 7-6      **ADRES<1:0>**: ADC Result Register bits  
Lower two bits of 10-bit conversion result.

bit 5-0      **Reserved**: Do not use

## REGISTER 15-6: ADRESH: ADC RESULT REGISTER HIGH (ADRESH) ADFM = 1

R/W-x/u	R/W-x/u	R/W-x/u	R/W-x/u	R/W-x/u	R/W-x/u	R/W-x/u	R/W-x/u
—	—	—	—	—	—	ADRES<9:8>	
bit 7							bit 0

### Legend:

R = Readable bit	W = Writable bit	
u = Bit is unchanged	x = Bit is unknown	U = Unimplemented bit, read as '0'
'1' = Bit is set	'0' = Bit is cleared	-n/n = Value at POR and BOR/Value at all other Resets

bit 7-2      **Reserved:** Do not use  
bit 1-0      **ADRES<9:8>:** ADC Result Register bits  
Upper two bits of 10-bit conversion result.

## REGISTER 15-7: ADRESL: ADC RESULT REGISTER LOW (ADRESL) ADFM = 1

R/W-x/u	R/W-x/u	R/W-x/u	R/W-x/u	R/W-x/u	R/W-x/u	R/W-x/u	R/W-x/u
ADRES<7:0>							
bit 7							bit 0

### Legend:

R = Readable bit	W = Writable bit	
u = Bit is unchanged	x = Bit is unknown	U = Unimplemented bit, read as '0'
'1' = Bit is set	'0' = Bit is cleared	-n/n = Value at POR and BOR/Value at all other Resets

bit 7-0      **ADRES<7:0>:** ADC Result Register bits  
Lower eight bits of 10-bit conversion result.

# PIC12(L)F1571/2

## 15.4 ADC Acquisition Requirements

For the ADC to meet its specified accuracy, the Charge Holding Capacitor (CHOLD) must be allowed to fully charge to the input channel voltage level. The Analog Input model is shown in [Figure 15-5](#). The Source Impedance ( $R_s$ ) and the internal Sampling Switch Impedance ( $R_{SS}$ ) directly affect the time required to charge the capacitor, CHOLD. The Sampling Switch Impedance ( $R_{SS}$ ) varies over the device voltage ( $V_{DD}$ ); refer to [Figure 15-5](#). **The maximum recommended impedance for analog sources is 10 k $\Omega$ .** As the

Source Impedance is decreased, the acquisition time may be decreased. After the analog input channel is selected (or changed), an ADC acquisition must be done before the conversion can be started. To calculate the minimum acquisition time, [Equation 15-1](#) may be used. This equation assumes that 1/2 LSB error is used (1,024 steps for the ADC). The 1/2 LSB error is the maximum error allowed for the ADC to meet its specified resolution.

### EQUATION 15-1: ACQUISITION TIME EXAMPLE

*Assumptions: Temperature = 50°C and external impedance of 10k $\Omega$  5.0V VDD*

$$\begin{aligned} T_{ACQ} &= \text{Amplifier Settling Time} + \text{Hold Capacitor Charging Time} + \text{Temperature Coefficient} \\ &= T_{AMP} + T_C + T_{COFF} \\ &= 2\mu\text{s} + T_C + [(Temperature - 25^\circ\text{C})(0.05\mu\text{s}/^\circ\text{C})] \end{aligned}$$

*The value for  $T_C$  can be approximated with the following equations:*

$$V_{APPLIED} \left( 1 - \frac{1}{(2^{n+1}) - 1} \right) = V_{CHOLD} \quad ;[1] \text{ } V_{CHOLD} \text{ charged to within } 1/2 \text{ lsb}$$

$$V_{APPLIED} \left( 1 - e^{-\frac{T_C}{RC}} \right) = V_{CHOLD} \quad ;[2] \text{ } V_{CHOLD} \text{ charge response to } V_{APPLIED}$$

$$V_{APPLIED} \left( 1 - e^{-\frac{T_C}{RC}} \right) = V_{APPLIED} \left( 1 - \frac{1}{(2^{n+1}) - 1} \right) \quad ;\text{combining [1] and [2]}$$

*Note: Where  $n$  = number of bits of the ADC.*

*Solving for  $T_C$ :*

$$\begin{aligned} T_C &= -CHOLD(R_{IC} + R_{SS} + R_s) \ln(1/2047) \\ &= -12.5\text{pF}(1\text{k}\Omega + 7\text{k}\Omega + 10\text{k}\Omega) \ln(0.0004885) \\ &= 1.715\mu\text{s} \end{aligned}$$

*Therefore:*

$$\begin{aligned} T_{ACQ} &= 2\mu\text{s} + 1.715\mu\text{s} + [(50^\circ\text{C} - 25^\circ\text{C})(0.05\mu\text{s}/^\circ\text{C})] \\ &= 4.96\mu\text{s} \end{aligned}$$

**Note 1:** The Reference Voltage ( $V_{RPOS}$ ) has no effect on the equation, since it cancels itself out.

**2:** The Charge Holding Capacitor (CHOLD) is not discharged after each conversion.

**3:** The maximum recommended impedance for analog sources is 10 k $\Omega$ . This is required to meet the pin leakage specification.

**FIGURE 15-5: ANALOG INPUT MODEL**

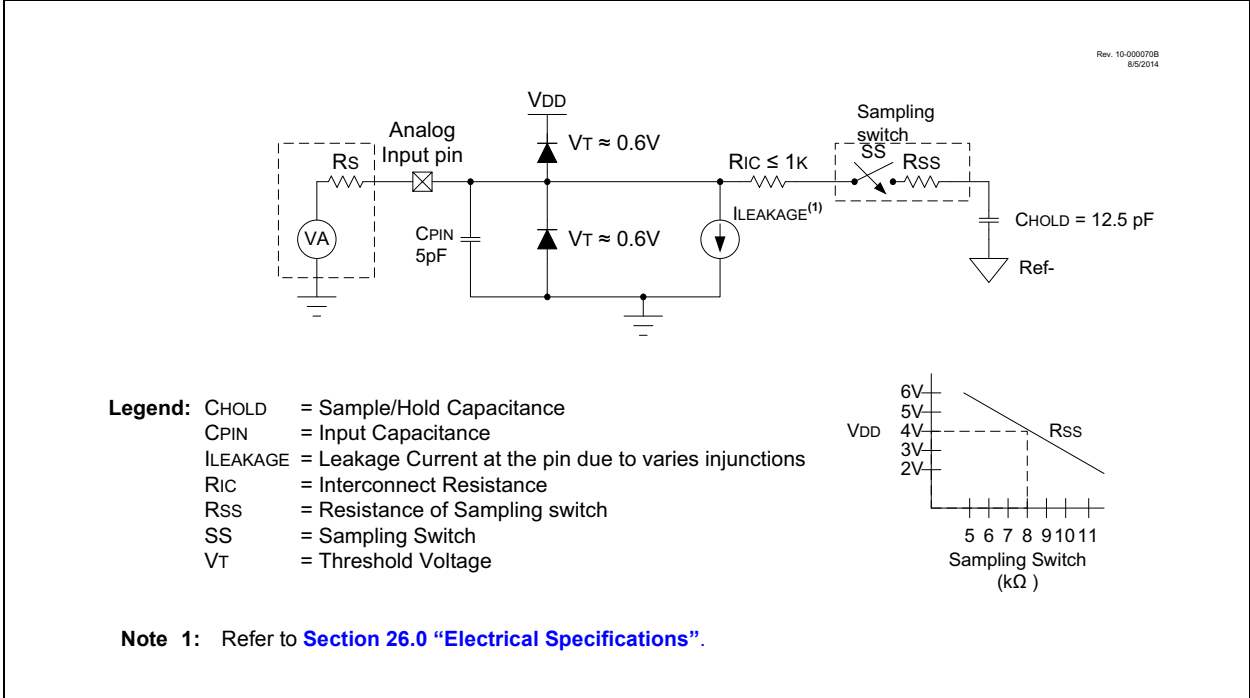

**FIGURE 15-6: ADC TRANSFER FUNCTION**

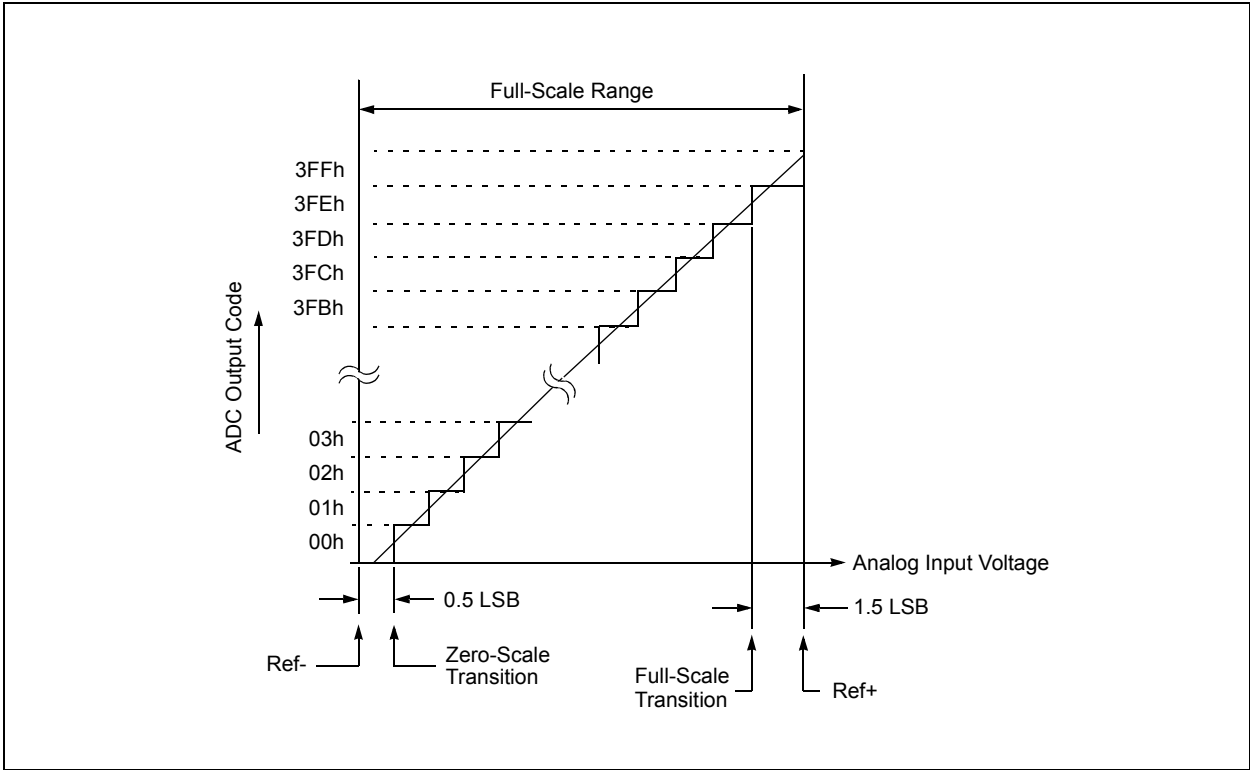

# PIC12(L)F1571/2

**TABLE 15-3: SUMMARY OF REGISTERS ASSOCIATED WITH ADC**

Name	Bit 7	Bit 6	Bit 5	Bit 4	Bit 3	Bit 2	Bit 1	Bit 0	Register on Page
ADCON0	—	CHS<4:0>					GO/DONE	ADON	135
ADCON1	ADFM	ADCS<2:0>			—	—	ADPREF<1:0>		136
ADCON2	TRIGSEL<3:0>			—	—	—	—	137	
ADRESH	ADC Result Register High								138, 139
ADRESL	ADC Result Register Low								138, 139
ANSELA	—	—	—	ANSA4	—	ANSA<2:0>			114
INTCON	GIE	PEIE	TMR0IE	INTE	IOCIE	TMR0IF	INTF	IOCIF	74
PIE1	TMR1GIE	ADIE	RCIE <sup>(2)</sup>	TXIE <sup>(2)</sup>	—	—	TMR2IE	TMR1IE	75
PIR1	TMR1GIF	ADIF	RCIF <sup>(2)</sup>	TXIF <sup>(2)</sup>	—	—	TMR2IF	TMR1IF	78
TRISA	—	—	TRISA5	TRISA4	— <sup>(1)</sup>	TRISA<2:0>			113
FVRCON	FVREN	FVRRDY	TSEN	TSRNG	CDAFVR<1:0>		ADFVR<1:0>		125

**Legend:** — = unimplemented, read as '0'. Shaded cells are not used for the ADC module.

**Note 1:** Unimplemented, read as '1'.

**2:** PIC12(L)F1572 only.

## 16.0 5-BIT DIGITAL-TO-ANALOG CONVERTER (DAC) MODULE

The Digital-to-Analog Converter supplies a variable voltage reference, ratiometric with the input source, with 32 selectable output levels.

The positive input source ( $V_{SOURCE+}$ ) of the DAC can be connected to the:

- External  $V_{REF+}$  pin
- $V_{DD}$  supply voltage
- FVR buffered output

The negative input source ( $V_{SOURCE-}$ ) of the DAC can be connected to the:

- $V_{SS}$

The output of the DAC ( $DACx\_output$ ) can be selected as a reference voltage to the following:

- Comparator positive input
- ADC input channel
- $DACxOUT1$  pin

The Digital-to-Analog Converter (DAC) can be enabled by setting the  $DACEN$  bit of the  $DACxCON0$  register.

**FIGURE 16-1: DIGITAL-TO-ANALOG CONVERTER BLOCK DIAGRAM**

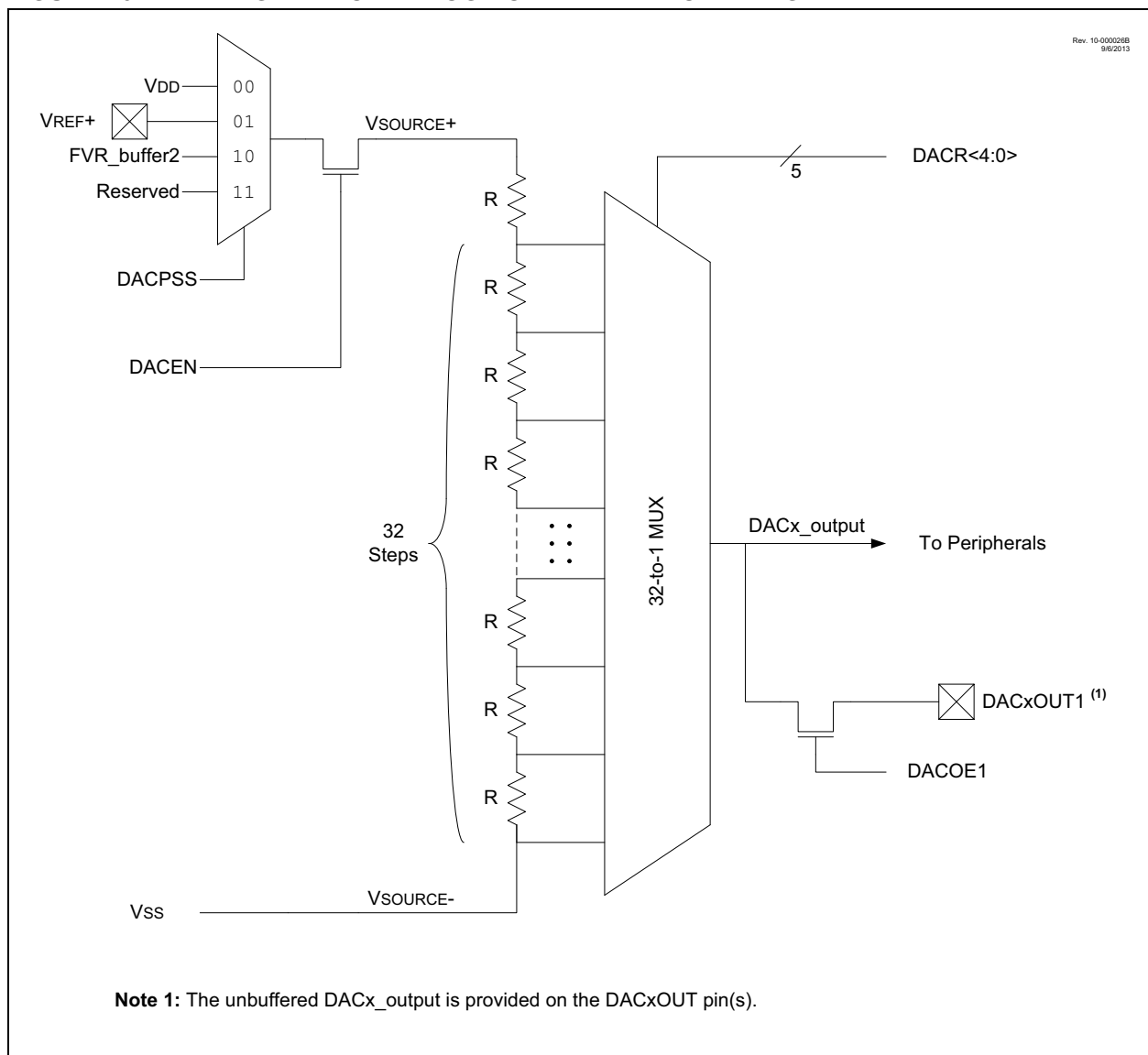

# PIC12(L)F1571/2

## 16.1 Output Voltage Selection

The DAC has 32 voltage level ranges. The 32 levels are set with the DACR<4:0> bits of the DACxCON1 register.

The DAC output voltage can be determined by using Equation 16-1.

## 16.2 Ratiometric Output Level

The DAC output value is derived using a resistor ladder with each end of the ladder tied to a positive and negative voltage reference input source. If the voltage of either input source fluctuates, a similar fluctuation will result in the DAC output value.

The value of the individual resistors within the ladder can be found in Table 26-16.

## 16.3 DAC Voltage Reference Output

The unbuffered DAC voltage can be output to the DACxOUTn pin(s) by setting the respective DACOEn bit(s) of the DACxCON0 register. Selecting the DAC reference voltage for output on either DACxOUTn pin automatically overrides the digital output buffer, the weak pull-up and digital input threshold detector functions of that pin.

Reading the DACxOUTn pin when it has been configured for DAC reference voltage output will always return a '0'.

**Note:** The unbuffered DAC output (DACxOUTn) is not intended to drive an external load.

## 16.4 Operation During Sleep

When the device wakes up from Sleep through an interrupt or a Watchdog Timer time-out, the contents of the DACxCON0 register are not affected. To minimize current consumption in Sleep mode, the voltage reference should be disabled.

## 16.5 Effects of a Reset

A device Reset affects the following:

- DACx is disabled.
- DACx output voltage is removed from the DACxOUTn pin(s).
- The DACR<4:0> range select bits are cleared.

### EQUATION 16-1: DAC OUTPUT VOLTAGE

***IF DACEN = 1***

$$DACx\_output = \left( (V_{SOURCE+} - V_{SOURCE-}) \times \frac{DACR[4:0]}{2^5} \right) + V_{SOURCE-}$$

**Note:** See the DACxCON0 register for the available VSOURCE+ and VSOURCE- selections.



## 16.6 Register Definitions: DAC Control

**REGISTER 16-1: DACxCON0: DACx VOLTAGE REFERENCE CONTROL REGISTER 0**

R/W-0/0	U-0	R/W-0/0	U-0	R/W-0/0	R/W-0/0	U-0	U-0
DACEN	—	DACOE	—	DACPSS<1:0>		—	—
bit 7							bit 0

**Legend:**

R = Readable bit                      W = Writable bit  
u = Bit is unchanged                  x = Bit is unknown                  U = Unimplemented bit, read as '0'  
'1' = Bit is set                          '0' = Bit is cleared                  -n/n = Value at POR and BOR/Value at all other Resets

bit 7            **DACEN:** DAC Enable bit  
                  1 = DACx is enabled  
                  0 = DACx is disabled

bit 6            **Unimplemented:** Read as '0'

bit 5            **DACOE:** DAC Voltage Output Enable bit  
                  1 = DACx voltage level is output on the DACxOUT1 pin  
                  0 = DACx voltage level is disconnected from the DACxOUT1 pin

bit 4            **Unimplemented:** Read as '0'

bit 3-2        **DACPSS<1:0>:** DAC Positive Source Select bits  
                  11 = Reserved  
                  10 = FVR\_buffer2  
                  01 = VREF+ pin  
                  00 = VDD

bit 1-0        **Unimplemented:** Read as '0'

**REGISTER 16-2: DACxCON1: DACx VOLTAGE REFERENCE CONTROL REGISTER 1**

U-0	U-0	U-0	R/W-0/0	R/W-0/0	R/W-0/0	R/W-0/0	R/W-0/0
—	—	—	DACR<4:0>				—
bit 7							bit 0

**Legend:**

R = Readable bit                      W = Writable bit  
u = Bit is unchanged                  x = Bit is unknown                  U = Unimplemented bit, read as '0'  
'1' = Bit is set                          '0' = Bit is cleared                  -n/n = Value at POR and BOR/Value at all other Resets

bit 7-5        **Unimplemented:** Read as '0'

bit 4-0        **DACR<4:0>:** DAC Voltage Output Select bits

**TABLE 16-1: SUMMARY OF REGISTERS ASSOCIATED WITH THE DAC MODULE**

Name	Bit 7	Bit 6	Bit 5	Bit 4	Bit 3	Bit 2	Bit 1	Bit 0	Register on Page
DACxCON0	DACEN	—	DACOE	—	DACPSS<1:0>		—	—	145
DACxCON1	—	—	—	DACR<4:0>				—	145

**Legend:** — = Unimplemented location, read as '0'.

# PIC12(L)F1571/2

---

NOTES:

## 17.0 COMPARATOR MODULE

Comparators are used to interface analog circuits to a digital circuit by comparing two analog voltages and providing a digital indication of their relative magnitudes. Comparators are very useful mixed signal building blocks because they provide analog functionality independent of program execution. The analog comparator module includes the following features:

- Independent comparator control
- Programmable input selection
- Comparator output is available internally/externally
- Programmable output polarity
- Interrupt-On-Change
- Wake-up from Sleep
- Programmable speed/power optimization
- PWM shutdown
- Programmable and Fixed Voltage Reference

## 17.1 Comparator Overview

A single comparator is shown in [Figure 17-2](#) along with the relationship between the analog input levels and the digital output. When the analog voltage at  $V_{IN+}$  is less than the analog voltage at  $V_{IN-}$ , the output of the comparator is a digital low level. When the analog voltage at  $V_{IN+}$  is greater than the analog voltage at  $V_{IN-}$ , the output of the comparator is a digital high level.

The comparators available for this device are listed in [Table 17-1](#).

**TABLE 17-1: AVAILABLE COMPARATORS**

Device	C1
PIC12(L)F1571	•
PIC12(L)F1572	•

**FIGURE 17-1: COMPARATOR MODULE SIMPLIFIED BLOCK DIAGRAM**

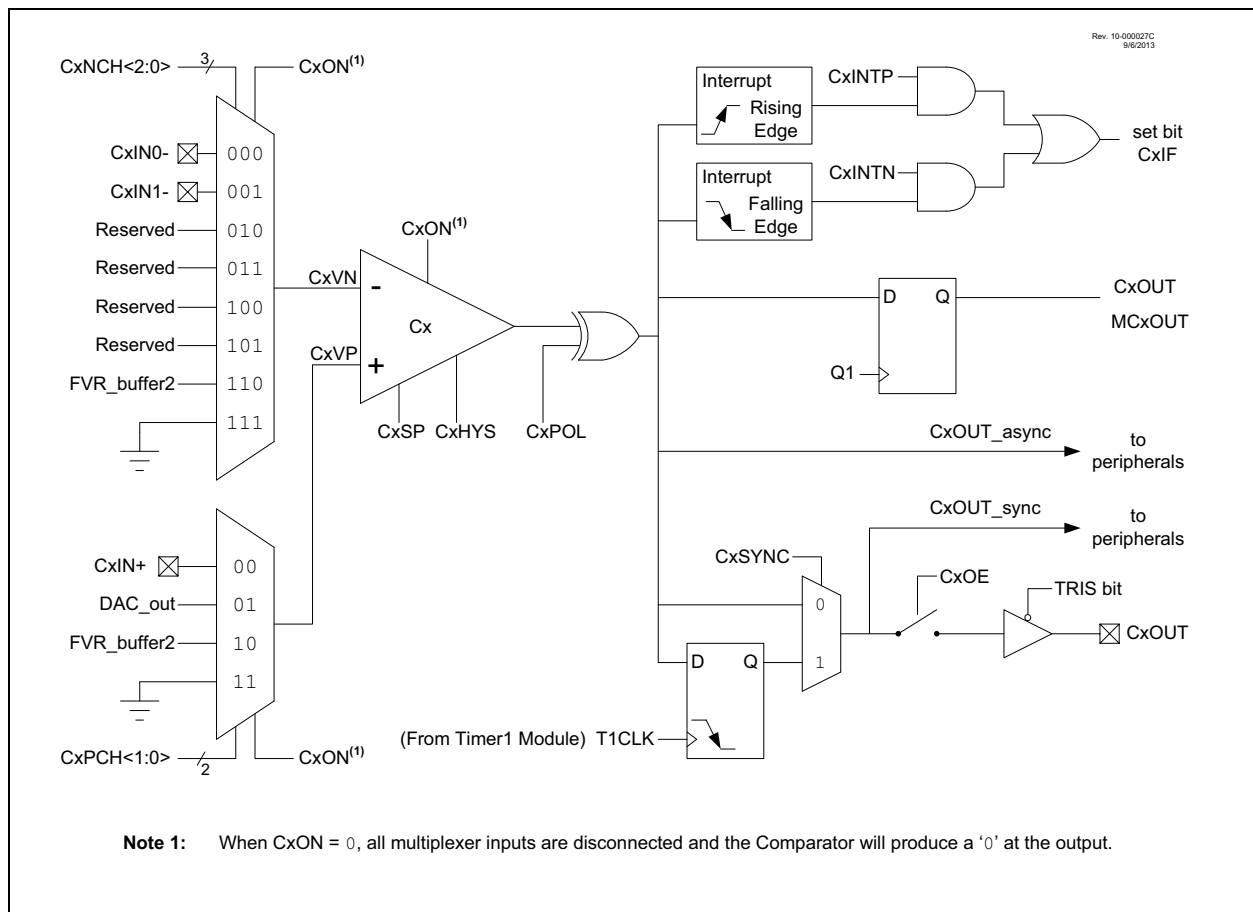

**FIGURE 17-2: SINGLE COMPARATOR**

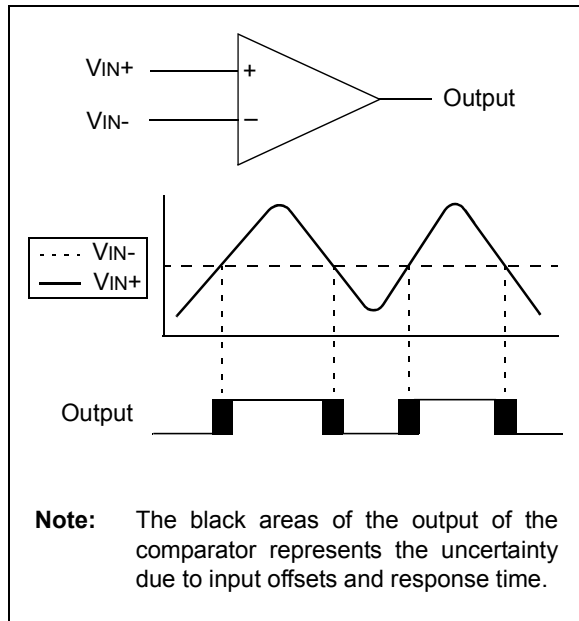

## 17.2 Comparator Control

The comparator has two control registers: CMxCON0 and CMxCON1.

The CMxCON0 register (see [Register 17-1](#)) contains control and status bits for the following:

- Enable
- Output selection
- Output polarity
- Speed/power selection
- Hysteresis enable
- Output synchronization

The CMxCON1 register (see [Register 17-2](#)) contains control bits for the following:

- Interrupt enable
- Interrupt edge polarity
- Positive input channel selection
- Negative input channel selection

### 17.2.1 COMPARATOR ENABLE

Setting the CxON bit of the CMxCON0 register enables the comparator for operation. Clearing the CxON bit disables the comparator resulting in minimum current consumption.

### 17.2.2 COMPARATOR POSITIVE INPUT SELECTION

Configuring the CxPCH<1:0> bits of the CMxCON1 register directs an internal voltage reference or an analog pin to the non-inverting input of the comparator:

- CxIN+ analog pin
- DAC1\_output
- FVR\_buffer2
- Vss

See [Section 13.0 “Fixed Voltage Reference \(FVR\)”](#) for more information on the Fixed Voltage Reference module.

See [Section 16.0 “5-Bit Digital-to-Analog Converter \(DAC\) Module”](#) for more information on the DAC input signal.

Any time the comparator is disabled (CxON = 0), all comparator inputs are disabled.

### 17.2.3 COMPARATOR NEGATIVE INPUT SELECTION

The CxNCH<2:0> bits of the CMxCON0 register direct one of the input sources to the comparator inverting input.

**Note:** To use CxIN+ and CxIN- pins as analog input, the appropriate bits must be set in the ANSELx register and the corresponding TRISx bits must also be set to disable the output drivers.

### 17.2.4 COMPARATOR OUTPUT SELECTION

The output of the comparator can be monitored by reading either the CxOUT bit of the CMxCON0 register or the MCxOUT bit of the CMOUT register. In order to make the output available for an external connection, the following conditions must be true:

- CxOE bit of the CMxCON0 register must be set
- Corresponding TRISx bit must be cleared
- CxON bit of the CMxCON0 register must be set

The synchronous comparator output signal (CxOUT\_sync) is available to the following peripheral(s):

- Analog-to-Digital Converter (ADC)
- Timer1

The asynchronous comparator output signal (CxOUT\_async) is available to the following peripheral(s):

- Complementary Waveform Generator (CWG)

**Note 1:** The CxOE bit of the CMxCON0 register overrides the port data latch. Setting the CxON bit of the CMxCON0 register has no impact on the port override.

**2:** The internal output of the comparator is latched with each instruction cycle. Unless otherwise specified, external outputs are not latched.

## 17.2.5 COMPARATOR OUTPUT POLARITY

Inverting the output of the comparator is functionally equivalent to swapping the comparator inputs. The polarity of the comparator output can be inverted by setting the CxPOL bit of the CMxCON0 register. Clearing the CxPOL bit results in a non-inverted output.

Table 17-2 shows the output state versus input conditions, including polarity control.

**TABLE 17-2: COMPARATOR OUTPUT STATE VS. INPUT CONDITIONS**

Input Condition	CxPOL	CxOUT
CxVN > CxVP	0	0
CxVN < CxVP	0	1
CxVN > CxVP	1	1
CxVN < CxVP	1	0

## 17.2.6 COMPARATOR SPEED/POWER SELECTION

The trade-off between speed or power can be optimized during program execution with the CxSP control bit. The default state for this bit is '1', which selects the Normal Speed mode. Device power consumption can be optimized at the cost of slower comparator propagation delay by clearing the CxSP bit to '0'.

## 17.3 Analog Input Connection Considerations

A simplified circuit for an analog input is shown in Figure 17-3. Since the analog input pins share their connection with a digital input, they have reverse biased ESD protection diodes to VDD and VSS. The analog input, therefore, must be between VSS and VDD. If the input voltage deviates from this range by more than 0.6V in either direction, one of the diodes is forward-biased and a latch-up may occur.

A maximum source impedance of 10 kΩ is recommended for the analog sources. Also, any external component connected to an analog input pin, such as a capacitor or a Zener diode, should have very little leakage current to minimize inaccuracies introduced.

**Note 1:** When reading a PORT register, all pins configured as analog inputs will read as a '0'. Pins configured as digital inputs will convert as an analog input, according to the input specification.

**2:** Analog levels on any pin defined as a digital input, may cause the input buffer to consume more current than is specified.

**FIGURE 17-3: ANALOG INPUT MODEL**

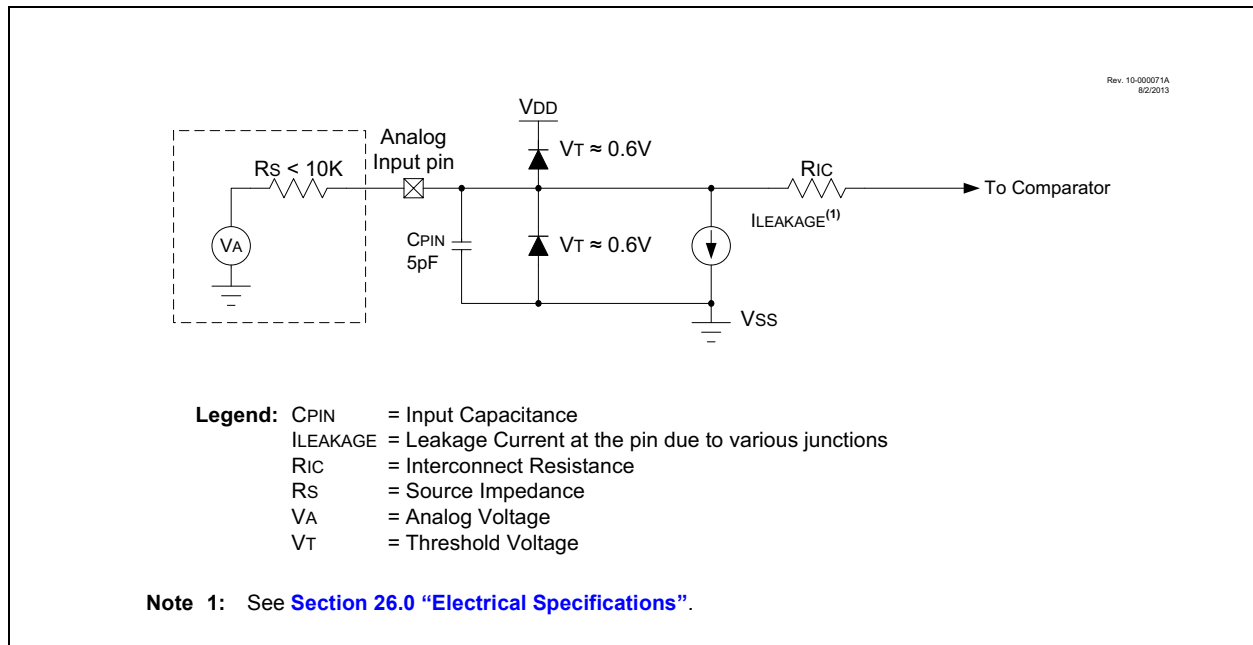

## 17.4 Comparator Hysteresis

A selectable amount of separation voltage can be added to the input pins of each comparator to provide a hysteresis function to the overall operation. Hysteresis is enabled by setting the CxHYS bit of the CMxCON0 register.

See [Section 26.0 “Electrical Specifications”](#) for more information.

## 17.5 Timer1 Gate Operation

The output resulting from a comparator operation can be used as a source for gate control of Timer1. See [Section 19.5 “Timer1 Gate”](#) for more information. This feature is useful for timing the duration or interval of an analog event.

It is recommended that the comparator output be synchronized to Timer1. This ensures that Timer1 does not increment while a change in the comparator is occurring.

### 17.5.1 COMPARATOR OUTPUT SYNCHRONIZATION

The output from the Cx comparator can be synchronized with Timer1 by setting the CxSYNC bit of the CMxCON0 register.

Once enabled, the comparator output is latched on the falling edge of the Timer1 source clock. If a prescaler is used with Timer1, the comparator output is latched after the prescaling function. To prevent a race condition, the comparator output is latched on the falling edge of the Timer1 clock source and Timer1 increments on the rising edge of its clock source. See the Comparator Block Diagram ([Figure 17-2](#)) and the Timer1 Block Diagram ([Figure 19-1](#)) for more information.

## 17.6 Comparator Interrupt

An interrupt can be generated upon a change in the output value of the comparator for each comparator, a rising edge detector and a falling edge detector are present.

When either edge detector is triggered and its associated enable bit is set (CxINTP and/or CxINTN bits of the CMxCON1 register), the corresponding interrupt flag bit (CxIF bit of the PIR2 register) will be set.

To enable the interrupt, you must set the following bits:

- CxON and CxPOL bits of the CMxCON0 register
- CxIE bit of the PIE2 register
- CxINTP bit of the CMxCON1 register (for a rising edge detection)
- CxINTN bit of the CMxCON1 register (for a falling edge detection)
- PEIE and GIE bits of the INTCON register

The associated interrupt flag bit, CxIF bit of the PIR2 register, must be cleared in software. If another edge is detected while this flag is being cleared, the flag will still be set at the end of the sequence.

<p><b>Note:</b> Although a comparator is disabled, an interrupt can be generated by changing the output polarity with the CxPOL bit of the CMxCON0 register, or by switching the comparator on or off with the CxON bit of the CMxCON0 register.</p>
--

## 17.7 Comparator Response Time

The comparator output is indeterminate for a period of time after the change of an input source or the selection of a new reference voltage. This period is referred to as the response time. The response time of the comparator differs from the settling time of the voltage reference. Therefore, both of these times must be considered when determining the total response time to a comparator input change. See the Comparator and Voltage Reference Specifications in [Section 26.0 “Electrical Specifications”](#) for more details.

## 17.8 Register Definitions: Comparator Control

**REGISTER 17-1: CMxCON0: COMPARATOR Cx CONTROL REGISTER 0**

R/W-0/0	R-0/0	R/W-0/0	R/W-0/0	U-0	R/W-0/0	R/W-0/0	R/W-0/0
CxON	CxOUT	CxOE	CxPOL	—	CxSP	CxHYS	CxSYNC
bit 7							bit 0

**Legend:**

R = Readable bit	W = Writable bit	
u = Bit is unchanged	x = Bit is unknown	U = Unimplemented bit, read as '0'
'1' = Bit is set	'0' = Bit is cleared	-n/n = Value at POR and BOR/Value at all other Resets

- bit 7      **CxON:** Comparator Enable bit  
           1 = Comparator is enabled  
           0 = Comparator is disabled and consumes no active power
- bit 6      **CxOUT:** Comparator Output bit  
           If CxPOL = 1 (inverted polarity):  
           1 = CxVP < CxVN  
           0 = CxVP > CxVN  
           If CxPOL = 0 (non-inverted polarity):  
           1 = CxVP > CxVN  
           0 = CxVP < CxVN
- bit 5      **CxOE:** Comparator Output Enable bit  
           1 = CxOUT is present on the CxOUT pin; requires that the associated TRISx bit be cleared to actually drive the pin, not affected by CxON  
           0 = CxOUT is internal only
- bit 4      **CxPOL:** Comparator Output Polarity Select bit  
           1 = Comparator output is inverted  
           0 = Comparator output is not inverted
- bit 3      **Unimplemented:** Read as '0'
- bit 2      **CxSP:** Comparator Speed/Power Select bit  
           1 = Comparator mode is in Normal Power, Higher Speed mode  
           0 = Comparator mode is in Low-Power, Low-Speed mode
- bit 1      **CxHYS:** Comparator Hysteresis Enable bit  
           1 = Comparator hysteresis is enabled  
           0 = Comparator hysteresis is disabled
- bit 0      **CxSYNC:** Comparator Output Synchronous Mode bit  
           1 = Comparator output to Timer1 and I/O pin is synchronous to changes on Timer1 clock source; output updated on the falling edge of Timer1 clock source  
           0 = Comparator output to Timer1 and I/O pin is asynchronous

# PIC12(L)F1571/2

## REGISTER 17-2: CMxCON1: COMPARATOR Cx CONTROL REGISTER 1

R/W-0/0	R/W-0/0	R/W-0/0	R/W-0/0	U-0	R/W-0/0	R/W-0/0	R/W-0/0
CxINTP	CxINTN	CxPCH<1:0>		—	CxNCH<2:0>		
bit 7							bit 0

### Legend:

R = Readable bit	W = Writable bit	
u = Bit is unchanged	x = Bit is unknown	U = Unimplemented bit, read as '0'
'1' = Bit is set	'0' = Bit is cleared	-n/n = Value at POR and BOR/Value at all other Resets

- bit 7      **CxINTP:** Comparator Interrupt on Positive Going Edge Enable bit  
 1 = The CxIF interrupt flag will be set upon a positive going edge of the CxOUT bit  
 0 = No interrupt flag will be set on a positive going edge of the CxOUT bit
- bit 6      **CxINTN:** Comparator Interrupt on Negative Going Edge Enable bit  
 1 = The CxIF interrupt flag will be set upon a negative going edge of the CxOUT bit  
 0 = No interrupt flag will be set on a negative going edge of the CxOUT bit
- bit 5-4    **CxPCH<1:0>:** Comparator Positive Input Channel Select bits  
 11 = CxVP connects to Vss  
 10 = CxVP connects to FVR Voltage Reference  
 01 = CxVP connects to DAC Voltage Reference  
 00 = CxVP connects to CxIN+ pin
- bit 3      **Unimplemented:** Read as '0'
- bit 2-0    **CxNCH<1:0>:** Comparator Negative Input Channel Select bits  
 111 = CxVN connects to GND  
 110 = CxVN connects to FVR Voltage Reference  
 101 = Reserved  
 100 = Reserved  
 011 = Reserved  
 010 = Reserved  
 001 = CxVN connects to CxIN1- pin  
 000 = CxVN connects to CxIN0- pin

## REGISTER 17-3: CMOUT: COMPARATOR OUTPUT REGISTER

U-0	U-0	U-0	U-0	U-0	U-0	U-0	R-0/0
—	—	—	—	—	—	—	MC1OUT
bit 7							bit 0

### Legend:

R = Readable bit	W = Writable bit	
u = Bit is unchanged	x = Bit is unknown	U = Unimplemented bit, read as '0'
'1' = Bit is set	'0' = Bit is cleared	-n/n = Value at POR and BOR/Value at all other Resets

- bit 7-1    **Unimplemented:** Read as '0'
- bit 0      **MC1OUT:** Mirror Copy of C1OUT bit



**TABLE 17-3: SUMMARY OF REGISTERS ASSOCIATED WITH COMPARATOR MODULE**

Name	Bit 7	Bit 6	Bit 5	Bit 4	Bit 3	Bit 2	Bit 1	Bit 0	Register on Page
ANSELA	—	—	—	ANSA4	—	ANSA<2:0>			114
CM1CON0	C1ON	C1OUT	C1OE	C1POL	—	C1SP	C1HYS	C1SYNC	151
CM1CON1	C1NTP	C1INTN	C1PCH<1:0>		—	C1NCH<2:0>			152
CMOUT	—	—	—	—	—	—	—	MC1OUT	152
DAC1CON0	DACEN	—	DACOE	—	DACPSS<1:0>		—	—	145
DAC1CON1	—	—	—	DACR<4:0>					145
FVRCON	FVREN	FVRRDY	TSEN	TSRNG	CDAFVR<1:0>		ADFVR<1:0>		125
INTCON	GIE	PEIE	TMR0IE	INTE	IOCIE	TMR0IF	INTF	IOCIF	74
PIE2	—	—	C1IE	—	—	—	—	—	76
PIR2	—	—	C1IF	—	—	—	—	—	79
PORTA	—	—	RA5	RA4	RA3	RA<2:0>			113
LATA	—	—	LATA5	LATA4	—	LATA<2:0>			114
TRISA	—	—	TRISA5	TRISA4	— <sup>(1)</sup>	TRISA<2:0>			113

**Legend:** — = unimplemented location, read as '0'. Shaded cells are unused by the comparator module.

**Note 1:** Unimplemented, read as '1'.

# PIC12(L)F1571/2

---

NOTES:

## 18.0 TIMER0 MODULE

The Timer0 module is an 8-bit timer/counter with the following features:

- 8-Bit Timer/Counter register (TMR0)
- 3-bit prescaler (independent of Watchdog Timer)
- Programmable internal or external clock source
- Programmable external clock edge selection
- Interrupt on overflow
- TMR0 can be used to gate Timer1

Figure 18-1 is a block diagram of the Timer0 module.

### 18.1 Timer0 Operation

The Timer0 module can be used as either an 8-bit timer or an 8-bit counter.

#### 18.1.1 8-BIT TIMER MODE

The Timer0 module will increment every instruction cycle if used without a prescaler. The 8-Bit Timer mode is selected by clearing the TMR0CS bit of the OPTION\_REG register.

When TMR0 is written, the increment is inhibited for two instruction cycles immediately following the write.

**Note:** The value written to the TMR0 register can be adjusted in order to account for the two instruction cycle delay when TMR0 is written.

#### 18.1.2 8-BIT COUNTER MODE

In 8-Bit Counter mode, the Timer0 module will increment on every rising or falling edge of the T0CKI pin.

In 8-Bit Counter mode, the T0CKI pin is selected by setting the TMR0CS bit in the OPTION\_REG register to '1'.

The rising or falling transition of the incrementing edge for either input source is determined by the TMR0SE bit in the OPTION\_REG register.

**FIGURE 18-1: TIMER0 BLOCK DIAGRAM**

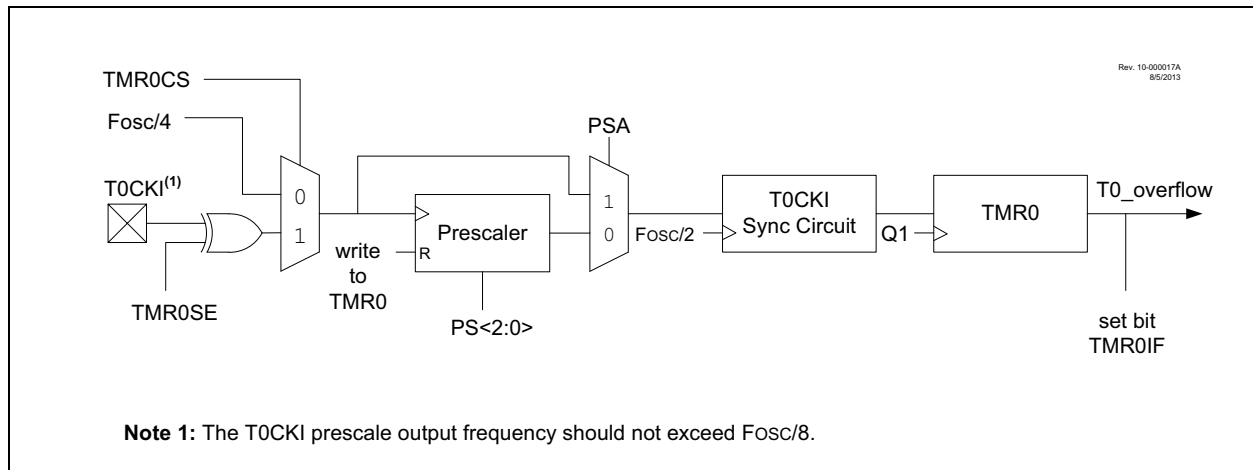

# PIC12(L)F1571/2

---

## 18.1.3 SOFTWARE PROGRAMMABLE PRESCALER

A software programmable prescaler is available for exclusive use with Timer0. The prescaler is enabled by clearing the PSA bit of the OPTION\_REG register.

**Note:** The Watchdog Timer (WDT) uses its own independent prescaler.

There are eight prescaler options for the Timer0 module, ranging from 1:2 to 1:256. The prescale values are selectable via the PS<2:0> bits of the OPTION\_REG register. In order to have a 1:1 prescaler value for the Timer0 module, the prescaler must be disabled by setting the PSA bit of the OPTION\_REG register.

The prescaler is not readable or writable. All instructions writing to the TMR0 register will clear the prescaler.

## 18.1.4 TIMER0 INTERRUPT

Timer0 will generate an interrupt when the TMR0 register overflows from FFh to 00h. The TMR0IF interrupt flag bit of the INTCON register is set every time the TMR0 register overflows, regardless of whether or not the Timer0 interrupt is enabled. The TMR0IF bit can only be cleared in software. The Timer0 interrupt enable is the TMR0IE bit of the INTCON register.

**Note:** The Timer0 interrupt cannot wake the processor from Sleep since the timer is frozen during Sleep.

## 18.1.5 8-BIT COUNTER MODE SYNCHRONIZATION

When in 8-Bit Counter mode, the incrementing edge on the T0CKI pin must be synchronized to the instruction clock. Synchronization can be accomplished by sampling the prescaler output on the Q2 and Q4 cycles of the instruction clock. The high and low periods of the external clocking source must meet the timing requirements as shown in [Section 26.0 “Electrical Specifications”](#).

## 18.1.6 OPERATION DURING SLEEP

Timer0 cannot operate while the processor is in Sleep mode. The contents of the TMR0 register will remain unchanged while the processor is in Sleep mode.

## 18.2 Register Definitions: Option Register

### REGISTER 18-1: OPTION\_REG: OPTION REGISTER

R/W-1/1	R/W-1/1	R/W-1/1	R/W-1/1	R/W-1/1	R/W-1/1	R/W-1/1	R/W-1/1
$\overline{\text{WPUEN}}$	INTEDG	TMR0CS	TMR0SE	PSA	PS<2:0>		
bit 7							bit 0

#### Legend:

R = Readable bit	W = Writable bit	
u = Bit is unchanged	x = Bit is unknown	U = Unimplemented bit, read as '0'
'1' = Bit is set	'0' = Bit is cleared	-n/n = Value at POR and BOR/Value at all other Resets

- bit 7  **$\overline{\text{WPUEN}}$** : Weak Pull-Up Enable bit  
 1 = All weak pull-ups are disabled (except  $\overline{\text{MCLR}}$  if it is enabled)  
 0 = Weak pull-ups are enabled by individual WPUx latch values
- bit 6 **INTEDG**: Interrupt Edge Select bit  
 1 = Interrupt on rising edge of INT pin  
 0 = Interrupt on falling edge of INT pin
- bit 5 **TMR0CS**: Timer0 Clock Source Select bit  
 1 = Transition on T0CKI pin  
 0 = Internal instruction cycle clock (FOSC/4)
- bit 4 **TMR0SE**: Timer0 Source Edge Select bit  
 1 = Increment on high-to-low transition on T0CKI pin  
 0 = Increment on low-to-high transition on T0CKI pin
- bit 3 **PSA**: Prescaler Assignment bit  
 1 = Prescaler is not assigned to the Timer0 module  
 0 = Prescaler is assigned to the Timer0 module
- bit 2-0 **PS<2:0>**: Prescaler Rate Select bits

Bit Value	Timer0 Rate
000	1 : 2
001	1 : 4
010	1 : 8
011	1 : 16
100	1 : 32
101	1 : 64
110	1 : 128
111	1 : 256

**TABLE 18-1: SUMMARY OF REGISTERS ASSOCIATED WITH TIMER0**

Name	Bit 7	Bit 6	Bit 5	Bit 4	Bit 3	Bit 2	Bit 1	Bit 0	Register on Page
ADCON2	TRIGSEL<3:0>				—	—	—	—	137
INTCON	GIE	PEIE	TMR0IE	INTE	IOCFIE	TMR0IF	INTF	IOCFIF	74
OPTION_REG	$\overline{\text{WPUEN}}$	INTEDG	TMR0CS	TMR0SE	PSA	PS<2:0>			157
TMR0	Holding Register for the 8-bit Timer0 Count								155*
TRISA	—	—	TRISA5	TRISA4	— <sup>(1)</sup>	TRISA2	TRISA1	TRISA0	113

**Legend:** — = unimplemented location, read as '0'. Shaded cells are not used by the Timer0 module.

\* Page provides register information.

**Note 1:** Unimplemented, read as '1'.

# PIC12(L)F1571/2

---

NOTES:

## 19.0 TIMER1 MODULE WITH GATE CONTROL

The Timer1 module is a 16-bit timer/counter with the following features:

- 16-bit Timer/Counter register pair (TMR1H:TMR1L)
- Programmable internal or external clock source
- 2-bit prescaler
- Optionally synchronized comparator out
- Multiple Timer1 gate (count enable) sources
- Interrupt on overflow

- Wake-up on overflow (external clock, Asynchronous mode only)
- ADC auto-conversion trigger(s)
- Selectable gate source polarity
- Gate Toggle mode
- Gate Single-Pulse mode
- Gate value status
- Gate event interrupt

Figure 19-1 is a block diagram of the Timer1 module.

**FIGURE 19-1: TIMER1 BLOCK DIAGRAM**

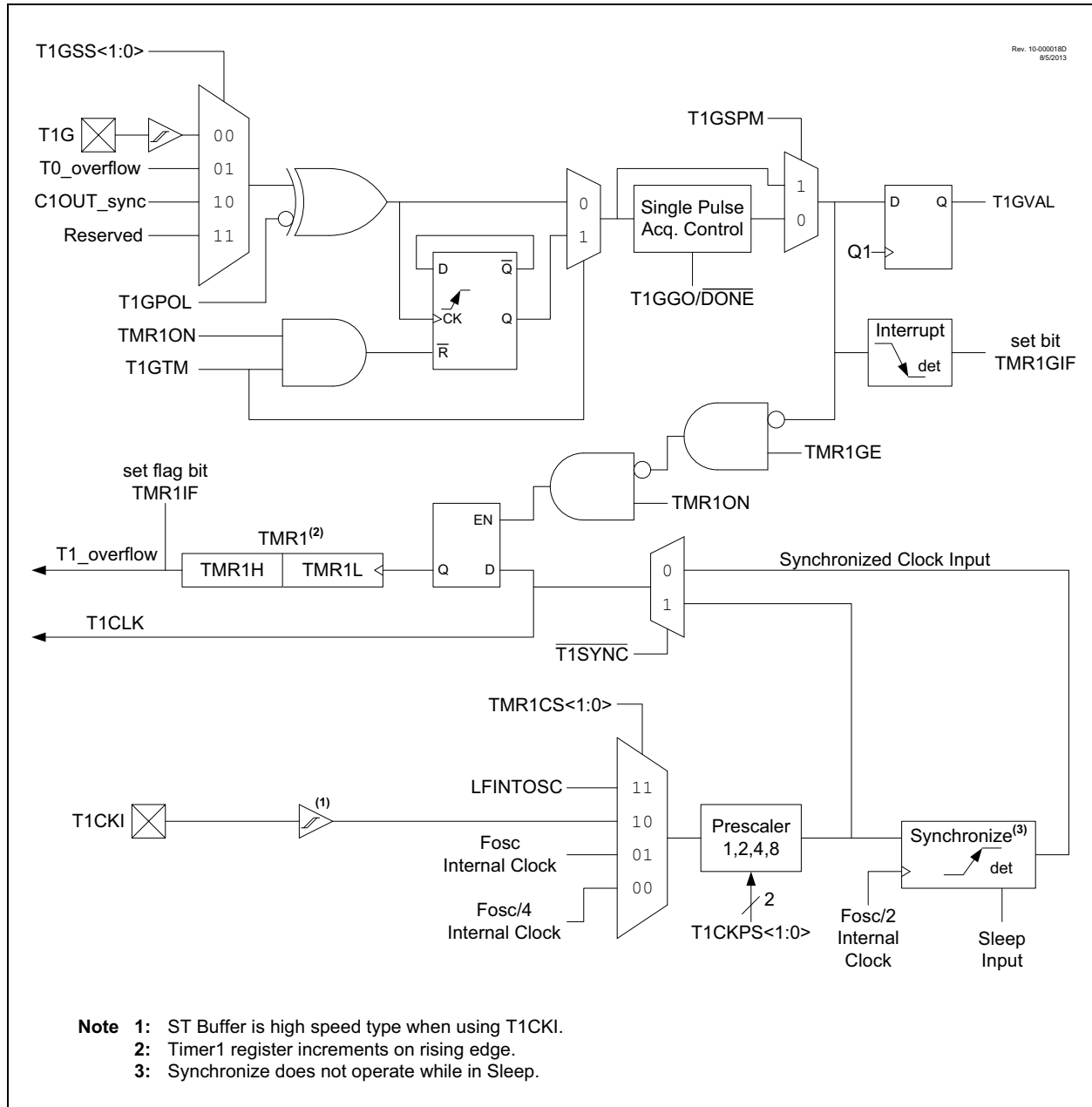

# PIC12(L)F1571/2

## 19.1 Timer1 Operation

The Timer1 module is a 16-bit incrementing counter which is accessed through the TMR1H:TMR1L register pair. Writes to TMR1H or TMR1L directly update the counter.

When used with an internal clock source, the module is a timer and increments on every instruction cycle. When used with an external clock source, the module can be used as either a timer or counter and increments on every selected edge of the external source.

Timer1 is enabled by configuring the TMR1ON and TMR1GE bits in the T1CON and T1GCON registers, respectively. Table 19-1 displays the Timer1 enable selections.

**TABLE 19-1: TIMER1 ENABLE SELECTIONS**

TMR1ON	TMR1GE	Timer1 Operation
0	0	Off
0	1	Off
1	0	Always On
1	1	Count Enabled

## 19.2 Clock Source Selection

The TMR1CS<1:0> bits of the T1CON register are used to select the clock source for Timer1. Table 19-2 displays the clock source selections.

### 19.2.1 INTERNAL CLOCK SOURCE

When the internal clock source is selected, the TMR1H:TMR1L register pair will increment on multiples of FOSC, as determined by the Timer1 prescaler.

When the Fosc internal clock source is selected, the Timer1 register value will increment by four counts every instruction clock cycle. Due to this condition, a 2 LSB error in resolution will occur when reading the Timer1 value. To utilize the full resolution of Timer1, an asynchronous input signal must be used to gate the Timer1 clock input.

The following asynchronous sources may be used:

- Asynchronous event on the T1G pin to Timer1 gate
- C1 or C2 comparator input to Timer1 gate

### 19.2.2 EXTERNAL CLOCK SOURCE

When the external clock source is selected, the Timer1 module may work as a timer or a counter.

When enabled to count, Timer1 is incremented on the rising edge of the external clock input T1CKI. The external clock source can be synchronized to the microcontroller system clock or it can run asynchronously.

**Note:** In Counter mode, a falling edge must be registered by the counter prior to the first incrementing rising edge after any one or more of the following conditions:

- Timer1 enabled after POR
- Write to TMR1H or TMR1L
- Timer1 is disabled
- Timer1 is disabled (TMR1ON = 0) when T1CKI is high, then Timer1 is enabled (TMR1ON = 1) when T1CKI is low

**TABLE 19-2: CLOCK SOURCE SELECTIONS**

TMR1CS<1:0>	T1OSCEN <sup>(1)</sup>	Clock Source
11	x	LFINTOSC
10	x	External Clocking on T1CKI Pin
01	x	System Clock (FOSC)
00	x	Instruction Clock (FOSC/4)

**Note 1:** T1OSCEN is not available for these devices.



## 19.3 Timer1 Prescaler

Timer1 has four prescaler options, allowing 1, 2, 4 or 8 divisions of the clock input. The T1CKPSx bits of the T1CON register control the prescale counter. The prescale counter is not directly readable or writable; however, the prescaler counter is cleared upon a write to TMR1H or TMR1L.

## 19.4 Timer1 Operation in Asynchronous Counter Mode

If control bit,  $\overline{T1SYNC}$ , of the T1CON register is set, the external clock input is not synchronized. The timer increments asynchronously to the internal phase clocks. If the external clock source is selected then the timer will continue to run during Sleep and can generate an interrupt on overflow, which will wake-up the processor. However, special precautions in software are needed to read/write the timer (see [Section 19.4.1 “Reading and Writing Timer1 in Asynchronous Counter Mode”](#)).

**Note:** When switching from synchronous to asynchronous operation, it is possible to skip an increment. When switching from asynchronous to synchronous operation, it is possible to produce an additional increment.

### 19.4.1 READING AND WRITING TIMER1 IN ASYNCHRONOUS COUNTER MODE

Reading TMR1H or TMR1L while the timer is running from an external asynchronous clock will ensure a valid read (taken care of in hardware). However, the user should keep in mind that reading the 16-bit timer in two 8-bit values itself, poses certain problems, since the timer may overflow between the reads.

For writes, it is recommended that the user simply stop the timer and write the desired values. A write contention may occur by writing to the timer registers, while the register is incrementing. This may produce an unpredictable value in the TMR1H:TMR1L register pair.

## 19.5 Timer1 Gate

Timer1 can be configured to count freely or the count can be enabled and disabled using Timer1 gate circuitry. This is also referred to as Timer1 Gate Enable.

Timer1 gate can also be driven by multiple selectable sources.

### 19.5.1 TIMER1 GATE ENABLE

The Timer1 Gate Enable mode is enabled by setting the TMR1GE bit of the T1GCON register. The polarity of the Timer1 Gate Enable mode is configured using the T1GPOL bit of the T1GCON register.

When Timer1 Gate Enable mode is enabled, Timer1 will increment on the rising edge of the Timer1 clock source. When Timer1 Gate Enable mode is disabled, no incrementing will occur and Timer1 will hold the current count. See [Figure 19-3](#) for timing details.

**TABLE 19-3: TIMER1 GATE ENABLE SELECTIONS**

T1CLK	T1GPOL	T1G	Timer1 Operation
↑	0	0	Counts
↑	0	1	Holds Count
↑	1	0	Holds Count
↑	1	1	Counts

### 19.5.2 TIMER1 GATE SOURCE SELECTION

Timer1 gate source selections are shown in [Table 19-4](#). Source selection is controlled by the T1GSS<1:0> bits of the T1GCON register. The polarity for each available source is also selectable. Polarity selection is controlled by the T1GPOL bit of the T1GCON register.

**TABLE 19-4: TIMER1 GATE SOURCES**

T1GSS<1:0>	Timer1 Gate Source
00	Timer1 Gate Pin (T1G)
01	Overflow of Timer0 (T0_overflow) (TMR0 increments from FFh to 00h)
10	Comparator 1 Output (C1OUT_sync) <sup>(1)</sup>
11	Reserved

**Note 1:** Optionally synchronized comparator output.

# PIC12(L)F1571/2

---

## 19.5.2.1 T1G Pin Gate Operation

The T1G pin is one source for Timer1 gate control. It can be used to supply an external source to the Timer1 gate circuitry.

## 19.5.2.2 Timer0 Overflow Gate Operation

When Timer0 increments from FFh to 00h, a low-to-high pulse will automatically be generated and internally supplied to the Timer1 gate circuitry.

## 19.5.3 TIMER1 GATE TOGGLE MODE

When Timer1 Gate Toggle mode is enabled, it is possible to measure the full cycle length of a Timer1 gate signal, as opposed to the duration of a single level pulse.

The Timer1 gate source is routed through a flip-flop that changes state on every incrementing edge of the signal. See [Figure 19-4](#) for timing details.

Timer1 Gate Toggle mode is enabled by setting the T1GTM bit of the T1GCON register. When the T1GTM bit is cleared, the flip-flop is cleared and held clear. This is necessary in order to control which edge is measured.

<b>Note:</b> Enabling Toggle mode at the same time as changing the gate polarity may result in indeterminate operation.
---

## 19.5.4 TIMER1 GATE SINGLE-PULSE MODE

When Timer1 Gate Single-Pulse mode is enabled, it is possible to capture a single-pulse gate event. Timer1 Gate Single-Pulse mode is first enabled by setting the T1GSPM bit in the T1GCON register. Next, the T1GGO/DONE bit in the T1GCON register must be set. The Timer1 will be fully enabled on the next incrementing edge. On the next trailing edge of the pulse, the T1GGO/DONE bit will automatically be cleared. No other gate events will be allowed to increment Timer1 until the T1GGO/DONE bit is once again set in software. See [Figure 19-5](#) for timing details.

If the Single-Pulse Gate mode is disabled by clearing the T1GSPM bit in the T1GCON register, the T1GGO/DONE bit should also be cleared.

Enabling the Toggle mode and the Single-Pulse mode simultaneously will permit both sections to work together. This allows the cycle times on the Timer1 gate source to be measured. See [Figure 19-6](#) for timing details.

## 19.5.5 TIMER1 GATE VALUE STATUS

When Timer1 gate value status is utilized, it is possible to read the most current level of the gate control value. The value is stored in the T1GVAL bit in the T1GCON register. The T1GVAL bit is valid even when the Timer1 gate is not enabled (TMR1GE bit is cleared).

## 19.5.6 TIMER1 GATE EVENT INTERRUPT

When Timer1 gate event interrupt is enabled, it is possible to generate an interrupt upon the completion of a gate event. When the falling edge of T1GVAL occurs, the TMR1GIF flag bit in the PIR1 register will be set. If the TMR1GIE bit in the PIE1 register is set, then an interrupt will be recognized.

The TMR1GIF flag bit operates even when the Timer1 gate is not enabled (TMR1GE bit is cleared).

## 19.6 Timer1 Interrupt

The Timer1 register pair (TMR1H:TMR1L) increments to FFFFh and rolls over to 0000h. When Timer1 rolls over, the Timer1 interrupt flag bit of the PIR1 register is set. To enable the interrupt on rollover, you must set these bits:

- TMR1ON bit of the T1CON register
- TMR1IE bit of the PIE1 register
- PEIE bit of the INTCON register
- GIE bit of the INTCON register

The interrupt is cleared by clearing the TMR1IF bit in the Interrupt Service Routine.

**Note:** The TMR1H:TMR1L register pair and the TMR1IF bit should be cleared before enabling interrupts.

The device will wake-up on an overflow and execute the next instructions. If the GIE bit of the INTCON register is set, the device will call the Interrupt Service Routine.

Timer1 oscillator will continue to operate in Sleep regardless of the T1SYNC bit setting.

### 19.7.1 ALTERNATE PIN LOCATIONS

This module incorporates I/O pins that can be moved to other locations with the use of the Alternate Pin Function register, APFCON. To determine which pins can be moved and what their default locations are upon a Reset, see [Section 11.1 “Alternate Pin Function”](#) for more information.

## 19.7 Timer1 Operation During Sleep

Timer1 can only operate during Sleep when set up in Asynchronous Counter mode. In this mode, an external crystal or clock source can be used to increment the counter. To set up the timer to wake the device:

- TMR1ON bit of the T1CON register must be set
- TMR1IE bit of the PIE1 register must be set
- PEIE bit of the INTCON register must be set
- T1SYNC bit of the T1CON register must be set
- TMR1CS bits of the T1CON register must be configured

**FIGURE 19-2: TIMER1 INCREMENTING EDGE**

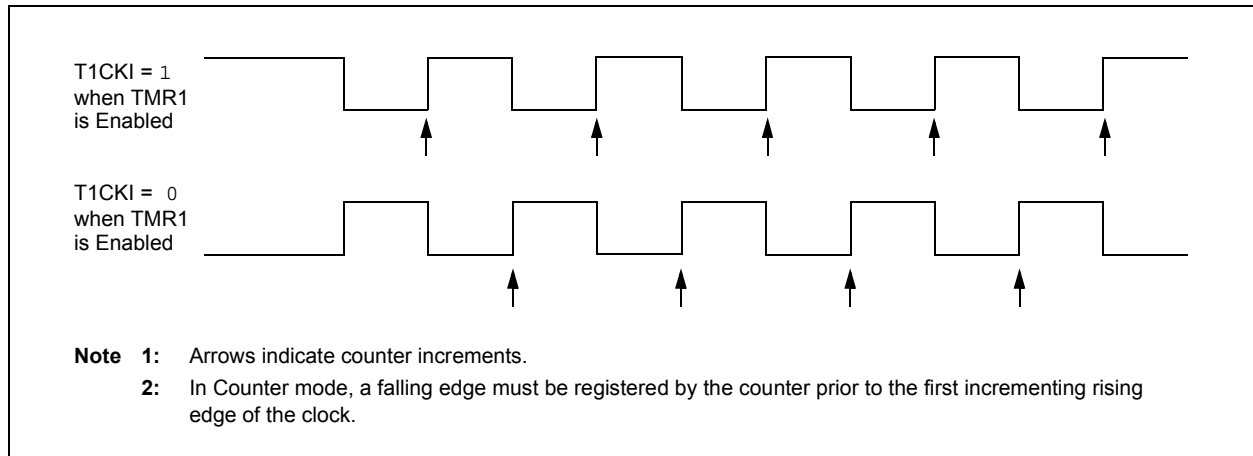

# PIC12(L)F1571/2

**FIGURE 19-3: TIMER1 GATE ENABLE MODE**

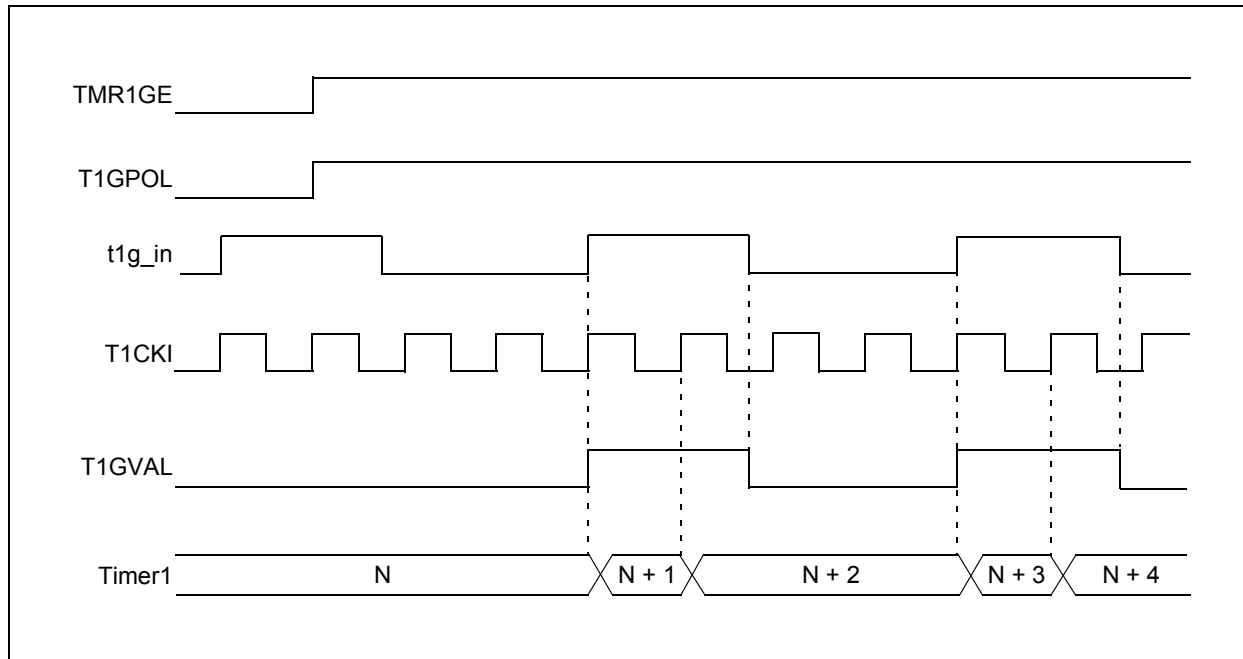

**FIGURE 19-4: TIMER1 GATE TOGGLE MODE**

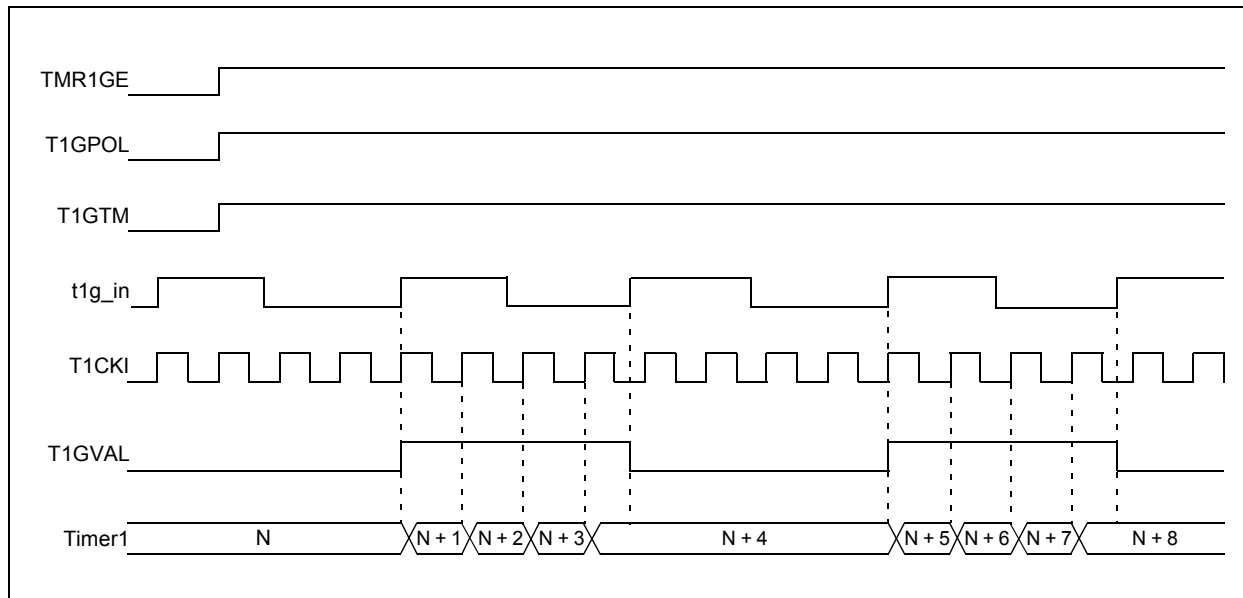
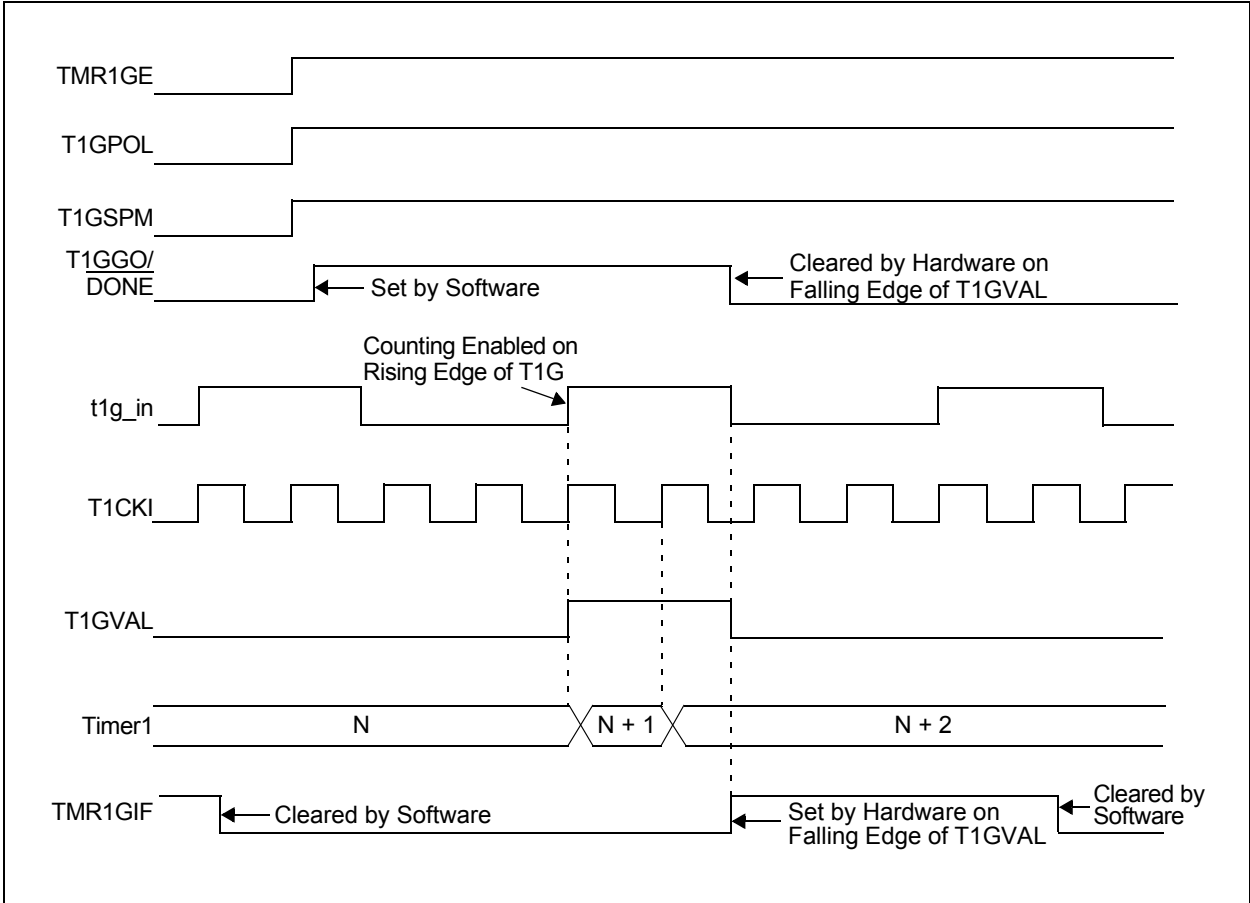
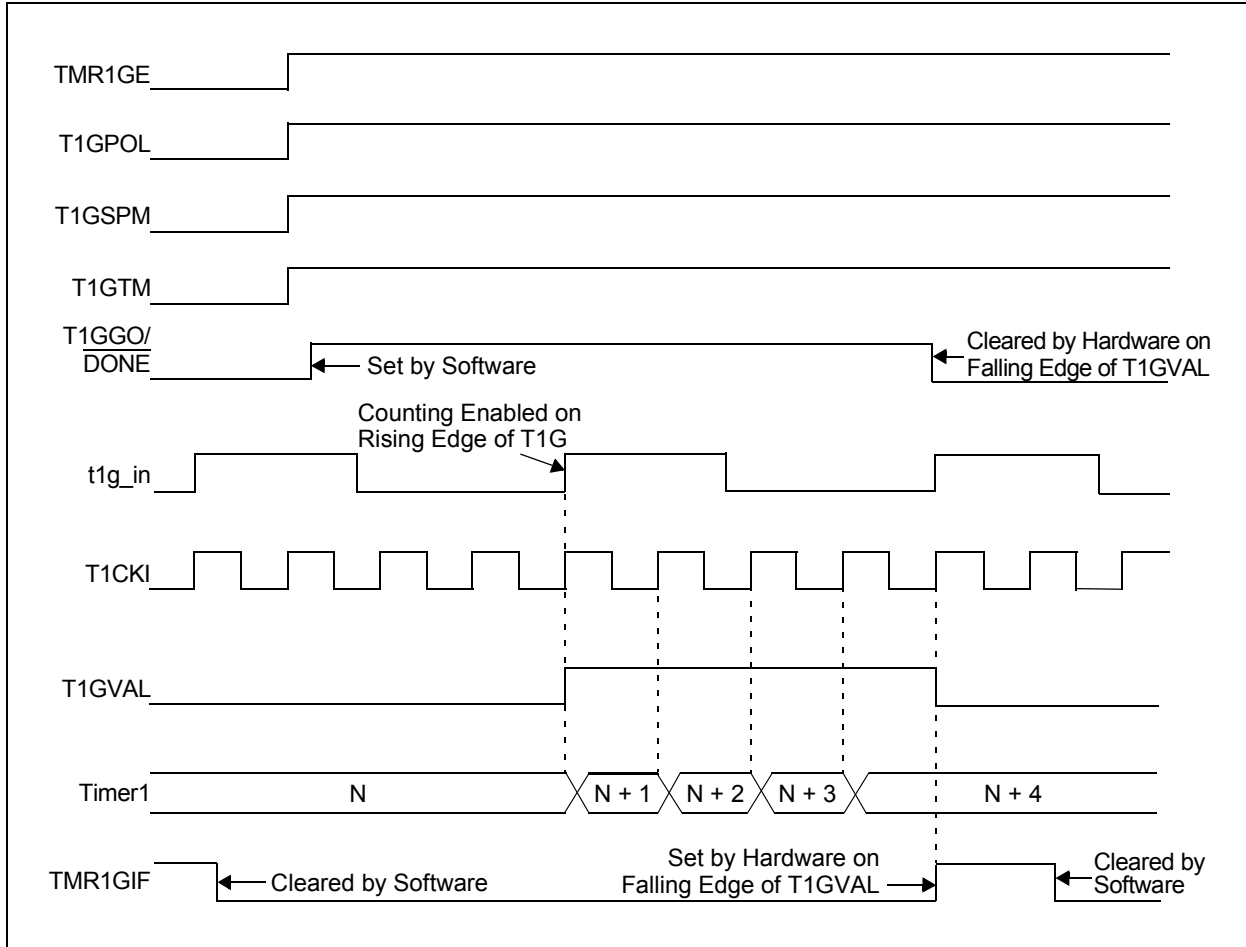

FIGURE 19-5: TIMER1 GATE SINGLE-PULSE MODE



# PIC12(L)F1571/2

**FIGURE 19-6: TIMER1 GATE SINGLE-PULSE AND TOGGLE COMBINED MODE**



## 19.8 Register Definitions: Timer1 Control

### REGISTER 19-1: T1CON: TIMER1 CONTROL REGISTER

R/W-0/u	R/W-0/u	R/W-0/u	R/W-0/u	U-0	R/W-0/u	U-0	R/W-0/u
TMR1CS<1:0>		T1CKPS<1:0>		—	T1SYNC	—	TMR1ON
bit 7							bit 0

#### Legend:

R = Readable bit

W = Writable bit

u = Bit is unchanged

x = Bit is unknown

U = Unimplemented bit, read as '0'

'1' = Bit is set

'0' = Bit is cleared

-n/n = Value at POR and BOR/Value at all other Resets

bit 7-6 **TMR1CS<1:0>**: Timer1 Clock Source Select bits

11 = Timer1 clock source is the LFINTOSC

10 = Timer1 clock source is the T1CKI pin (on the rising edge)

01 = Timer1 clock source is the system clock (Fosc)

00 = Timer1 clock source is the instruction clock (Fosc/4)

bit 5-4 **T1CKPS<1:0>**: Timer1 Input Clock Prescale Select bits

11 = 1:8 Prescale value

10 = 1:4 Prescale value

01 = 1:2 Prescale value

00 = 1:1 Prescale value

bit 3 **Unimplemented**: Read as '0'

bit 2 **T1SYNC**: Timer1 Synchronization Control bit

1 = Does not synchronize the asynchronous clock input

0 = Synchronizes the asynchronous clock input with the system clock (Fosc)

bit 1 **Unimplemented**: Read as '0'

bit 0 **TMR1ON**: Timer1 On bit

1 = Enables Timer1

0 = Stops Timer1 and clears Timer1 gate flip-flop

# PIC12(L)F1571/2

## REGISTER 19-2: T1GCON: TIMER1 GATE CONTROL REGISTER

R/W-0/u	R/W-0/u	R/W-0/u	R/W-0/u	R/W/HC-0/u	R-x/x	R/W-0/u	R/W-0/u
TMR1GE	T1GPOL	T1GTM	T1GSPM	T1GGO/ DONE	T1GVAL	T1GSS<1:0>	
bit 7						bit 0	

### Legend:

R = Readable bit	W = Writable bit	HC = Hardware Clearable bit
u = Bit is unchanged	x = Bit is unknown	U = Unimplemented bit, read as '0'
'1' = Bit is set	'0' = Bit is cleared	-n/n = Value at POR and BOR/Value at all other Resets

- bit 7      **TMR1GE:** Timer1 Gate Enable bit  
If TMR1ON = 0:  
This bit is ignored.  
If TMR1ON = 1:  
1 = Timer1 counting is controlled by the Timer1 gate function  
0 = Timer1 counts regardless of Timer1 gate function
- bit 6      **T1GPOL:** Timer1 Gate Polarity bit  
1 = Timer1 gate is active-high (Timer1 counts when gate is high)  
0 = Timer1 gate is active-low (Timer1 counts when gate is low)
- bit 5      **T1GTM:** Timer1 Gate Toggle Mode bit  
1 = Timer1 Gate Toggle mode is enabled  
0 = Timer1 Gate Toggle mode is disabled and toggle flip-flop is cleared  
Timer1 gate flip-flop toggles on every rising edge.
- bit 4      **T1GSPM:** Timer1 Gate Single-Pulse Mode bit  
1 = Timer1 Gate Single-Pulse mode is enabled and is controlling Timer1 gate  
0 = Timer1 Gate Single-Pulse mode is disabled
- bit 3      **T1GGO/DONE:** Timer1 Gate Single-Pulse Acquisition Status bit  
1 = Timer1 gate single-pulse acquisition is ready, waiting for an edge  
0 = Timer1 gate single-pulse acquisition has completed or has not been started
- bit 2      **T1GVAL:** Timer1 Gate Value Status bit  
Indicates the current state of the Timer1 gate that could be provided to TMR1H:TMR1L. Unaffected by Timer1 Gate Enable bit (TMR1GE).
- bit 1-0    **T1GSS<1:0>:** Timer1 Gate Source Select bits  
11 = Reserved  
10 = Comparator 1 optionally synchronized output (C1OUT\_sync)  
01 = Timer0 overflow output (T0\_overflow)  
00 = Timer1 gate pin (T1G)



**TABLE 19-5: SUMMARY OF REGISTERS ASSOCIATED WITH TIMER1**

Name	Bit 7	Bit 6	Bit 5	Bit 4	Bit 3	Bit 2	Bit 1	Bit 0	Register on Page
ANSELA	—	—	—	ANSA4	—	ANSA<2:0>			114
APFCON	RXDTSEL	CWGASEL	CWGBSEL	—	T1GSEL	TXCKSEL	P2SEL	P1SEL	110
INTCON	GIE	PEIE	TMR0IE	INTE	IOIE	TMR0IF	INTF	IOCF	74
OSCSTAT	—	PLL	OSTS	HFIOFR	HFIOFL	MFIOFR	LFIOFR	HFIOFS	56
PIE1	TMR1GIE	ADIE	RCIE <sup>(2)</sup>	TXIE <sup>(2)</sup>	—	—	TMR2IE	TMR1IE	75
PIR1	TMR1GIF	ADIF	RCIF <sup>(2)</sup>	TXIF <sup>(2)</sup>	—	—	TMR2IF	TMR1IF	79
TMR1H	Holding Register for the Most Significant Byte of the 16-bit TMR1 Count								163*
TMR1L	Holding Register for the Least Significant Byte of the 16-bit TMR1 Count								163*
TRISA	—	—	TRISA<5:4>		— <sup>(1)</sup>	TRISA<2:0>			113
T1CON	TMR1CS<1:0>		T1CKPS<1:0>		—	T1SYNC	—	TMR1ON	167
T1GCON	TMR1GE	T1GPOL	T1GTM	T1GSPM	T1GGO/ DONE	T1GVAL	T1GSS<1:0>		168

**Legend:** — = unimplemented location, read as '0'. Shaded cells are not used by the Timer1 module.

\* Page provides register information.

**Note 1:** Unimplemented, read as '1'.

**2:** PIC12(L)F1572 only.

# PIC12(L)F1571/2

---

NOTES:

## 20.0 TIMER2 MODULE

The Timer2 module incorporates the following features:

- 8-Bit Timer and Period registers (TMR2 and PR2, respectively)
- Readable and writable (both registers)
- Software programmable prescaler (1:1, 1:4, 1:16 and 1:64)
- Software programmable postscaler (1:1 to 1:16)
- Interrupt on TMR2 match with PR2

See [Figure 20-1](#) for a block diagram of Timer2.

**FIGURE 20-1: TIMER2 BLOCK DIAGRAM**

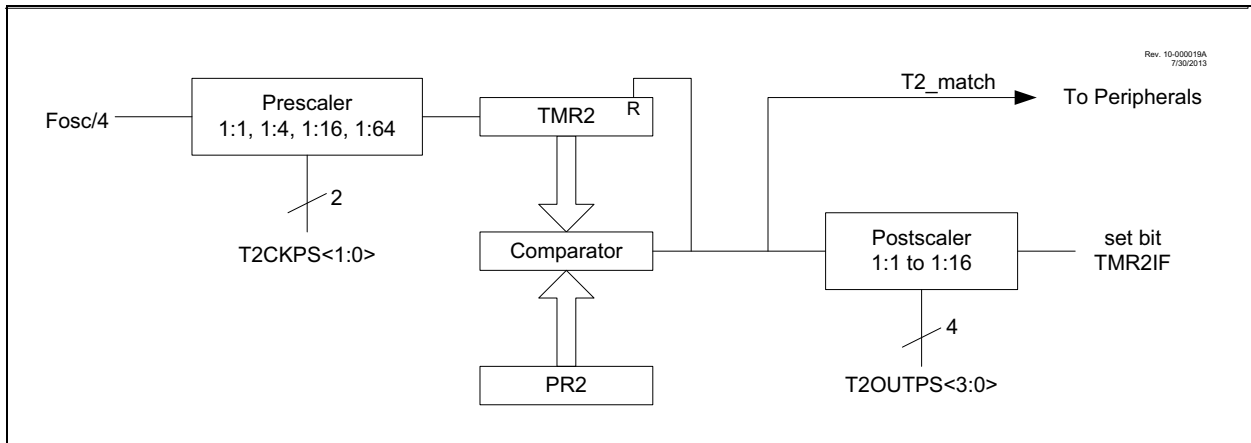

**FIGURE 20-2: TIMER2 TIMING DIAGRAM**

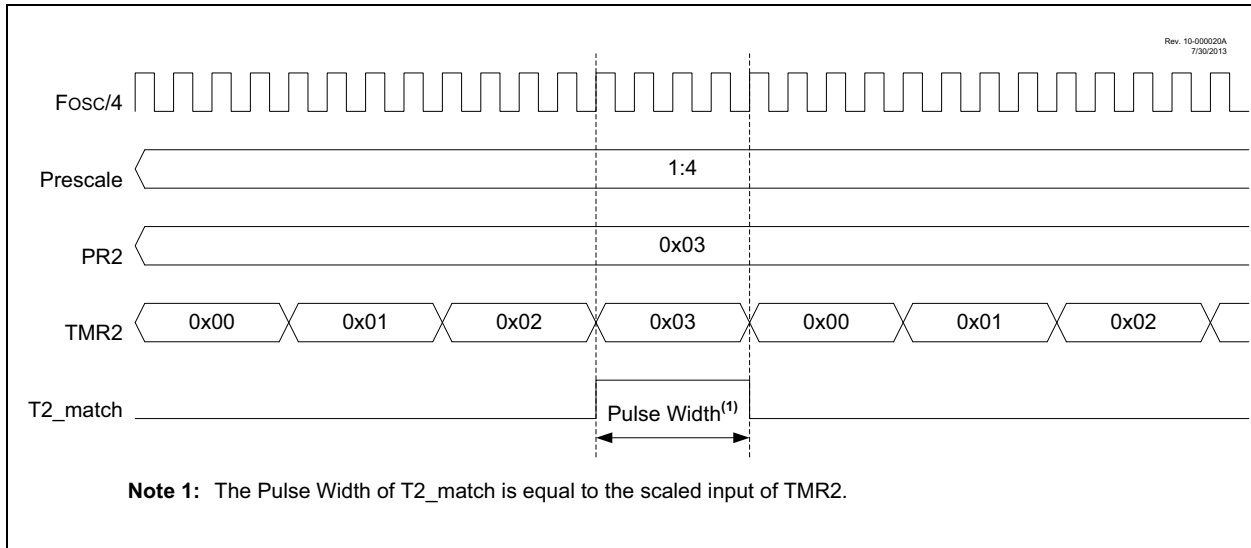

# PIC12(L)F1571/2

## 20.1 Timer2 Operation

The clock input to the Timer2 module is the system instruction clock ( $F_{osc}/4$ ).

TMR2 increments from 00h on each clock edge.

A 4-bit counter/prescaler on the clock input allows direct input, divide-by-4 and divide-by-16 prescale options. These options are selected by the prescaler control bits,  $T2CKPS<1:0>$  of the T2CON register. The value of TMR2 is compared to that of the Period register, PR2, on each clock cycle. When the two values match, the comparator generates a match signal as the timer output. This signal also resets the value of TMR2 to 00h on the next cycle and drives the output counter/postscaler (see [Section 20.2 “Timer2 Interrupt”](#)).

The TMR2 and PR2 registers are both directly readable and writable. The TMR2 register is cleared on any device Reset, whereas the PR2 register initializes to FFh. Both the prescaler and postscaler counters are cleared on the following events:

- A write to the TMR2 register
- A write to the T2CON register
- Power-on Reset (POR)
- Brown-out Reset (BOR)
- MCLR Reset
- Watchdog Timer (WDT) Reset
- Stack Overflow Reset
- Stack Underflow Reset
- RESET Instruction

**Note:** TMR2 is not cleared when T2CON is written.

## 20.2 Timer2 Interrupt

Timer2 can also generate an optional device interrupt. The Timer2 output signal (T2\_match) provides the input for the 4-bit counter/postscaler. This counter generates the TMR2 match interrupt flag which is latched in TMR2IF of the PIR1 register. The interrupt is enabled by setting the TMR2 Match Interrupt Enable bit, TMR2IE of the PIE1 register.

A range of 16 postscale options (from 1:1 through 1:16 inclusive) can be selected with the postscaler control bits,  $T2OUTPS<3:0>$ , of the T2CON register.

## 20.3 Timer2 Output

The output of TMR2 is T2\_match.

The T2\_match signal is synchronous with the system clock. [Figure 20-3](#) shows two examples of the timing of the T2\_match signal relative to  $F_{osc}$  and prescale value,  $T2CKPS<1:0>$ . The upper diagram illustrates 1:1 prescale timing and the lower diagram, 1:X prescale timing.

**FIGURE 20-3: T2\_MATCH TIMING DIAGRAM**

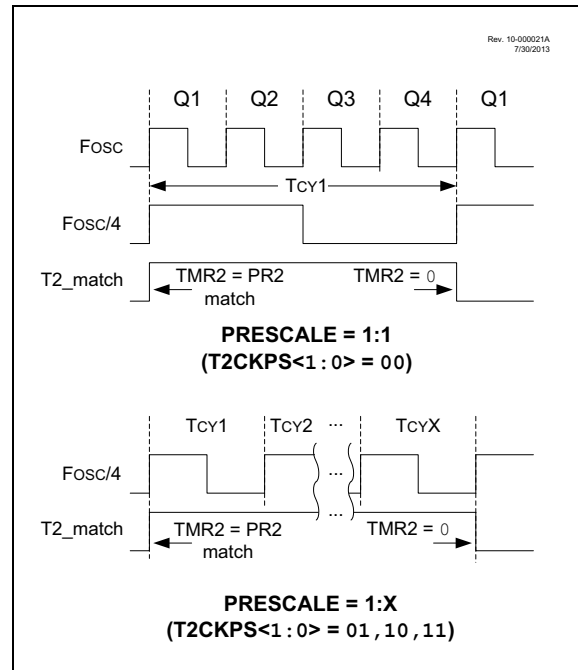

## 20.4 Timer2 Operation During Sleep

Timer2 cannot be operated while the processor is in Sleep mode. The contents of the TMR2 and PR2 registers will remain unchanged while the processor is in Sleep mode.

## 20.5 Register Definitions: Timer2 Control

### REGISTER 20-1: T2CON: TIMER2 CONTROL REGISTER

U-0	R/W-0/0	R/W-0/0	R/W-0/0	R/W-0/0	R/W-0/0	R/W-0/0	R/W-0/0
—	T2OUTPS<3:0>			TMR2ON	T2CKPS<1:0>		
bit 7				bit 0			

#### Legend:

R = Readable bit	W = Writable bit	
u = Bit is unchanged	x = Bit is unknown	U = Unimplemented bit, read as '0'
'1' = Bit is set	'0' = Bit is cleared	-n/n = Value at POR and BOR/Value at all other Resets

bit 7	<b>Unimplemented:</b> Read as '0'
bit 6-3	<b>T2OUTPS&lt;3:0&gt;:</b> Timer2 Output Postscaler Select bits 0000 = 1:1 Postscaler 0001 = 1:2 Postscaler 0010 = 1:3 Postscaler 0011 = 1:4 Postscaler 0100 = 1:5 Postscaler 0101 = 1:6 Postscaler 0110 = 1:7 Postscaler 0111 = 1:8 Postscaler 1000 = 1:9 Postscaler 1001 = 1:10 Postscaler 1010 = 1:11 Postscaler 1011 = 1:12 Postscaler 1100 = 1:13 Postscaler 1101 = 1:14 Postscaler 1110 = 1:15 Postscaler 1111 = 1:16 Postscaler
bit 2	<b>TMR2ON:</b> Timer2 On bit 1 = Timer2 is on 0 = Timer2 is off
bit 1-0	<b>T2CKPS&lt;1:0&gt;:</b> Timer2 Clock Prescale Select bits 00 = Prescaler is 1 01 = Prescaler is 4 10 = Prescaler is 16 11 = Prescaler is 64

**TABLE 20-1: SUMMARY OF REGISTERS ASSOCIATED WITH TIMER2**

Name	Bit 7	Bit 6	Bit 5	Bit 4	Bit 3	Bit 2	Bit 1	Bit 0	Register on Page
INTCON	GIE	PEIE	TMR0IE	INTE	IOCIE	TMR0IF	INTF	IOCIF	74
PIE1	TMR1GIE	ADIE	RCIE <sup>(1)</sup>	TXIE <sup>(1)</sup>	—	—	TMR2IE	TMR1IE	75
PIR1	TMR1GIF	ADIF	RCIF <sup>(1)</sup>	TXIF <sup>(1)</sup>	—	—	TMR2IF	TMR1IF	78
PR2	Timer2 Module Period Register								171*
T2CON	—	T2OUTPS<3:0>			TMR2ON	T2CKPS<1:0>			173
TMR2	Holding Register for the 8-bit TMR2 Count								171*

**Legend:** — = unimplemented location, read as '0'. Shaded cells are not used for Timer2 module.

\* Page provides register information.

**Note 1:** PIC12(L)F1572 only.

# PIC12(L)F1571/2

---

NOTES:

## 21.0 ENHANCED UNIVERSAL SYNCHRONOUS ASYNCHRONOUS RECEIVER TRANSMITTER (EUSART)

The Enhanced Universal Synchronous Asynchronous Receiver Transmitter (EUSART) module is a serial I/O communications peripheral. It contains all the clock generators, shift registers and data buffers necessary to perform an input or output serial data transfer, independent of device program execution. The EUSART, also known as a Serial Communications Interface (SCI), can be configured as a full-duplex asynchronous system or half-duplex synchronous system. Full-Duplex mode is useful for communications with peripheral systems, such as CRT terminals and personal computers. Half-Duplex Synchronous mode is intended for communications with peripheral devices, such as A/D or D/A integrated circuits, serial EEPROMs or other microcontrollers. These devices typically do not have internal clocks for baud rate generation and require the external clock signal provided by a master synchronous device.

The EUSART module includes the following capabilities:

- Full-duplex asynchronous transmit and receive
- Two-character input buffer
- One-character output buffer
- Programmable 8-bit or 9-bit character length
- Address detection in 9-bit mode
- Input buffer overrun error detection
- Received character framing error detection
- Half-duplex synchronous master
- Half-duplex synchronous slave
- Programmable clock polarity in synchronous modes
- Sleep operation

The EUSART module implements the following additional features, making it ideally suited for use in Local Interconnect Network (LIN) bus systems:

- Automatic detection and calibration of the baud rate
- Wake-up on Break reception
- 13-bit Break character transmit

Block diagrams of the EUSART transmitter and receiver are shown in [Figure 21-1](#) and [Figure 21-2](#).

**FIGURE 21-1: EUSART TRANSMIT BLOCK DIAGRAM**

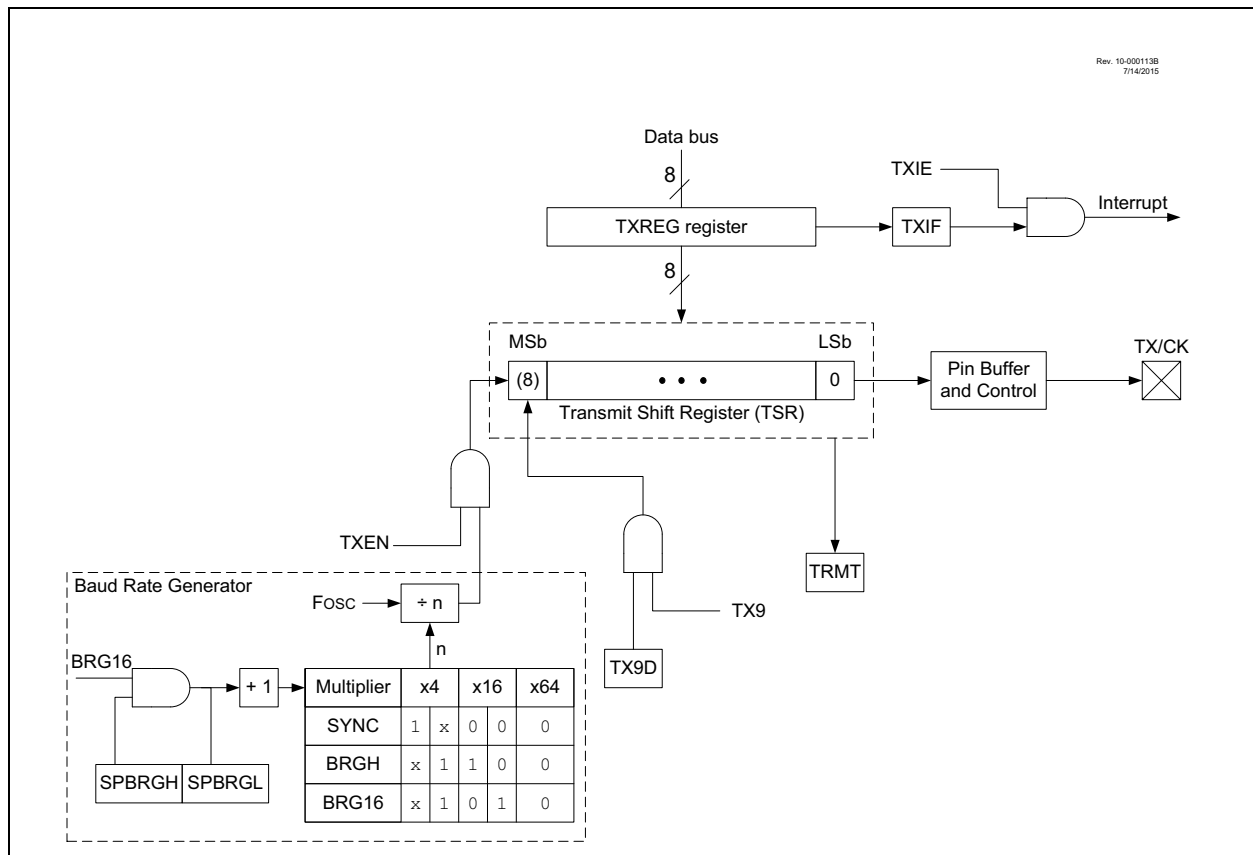

# PIC12(L)F1571/2

**FIGURE 21-2: EUSART RECEIVE BLOCK DIAGRAM**

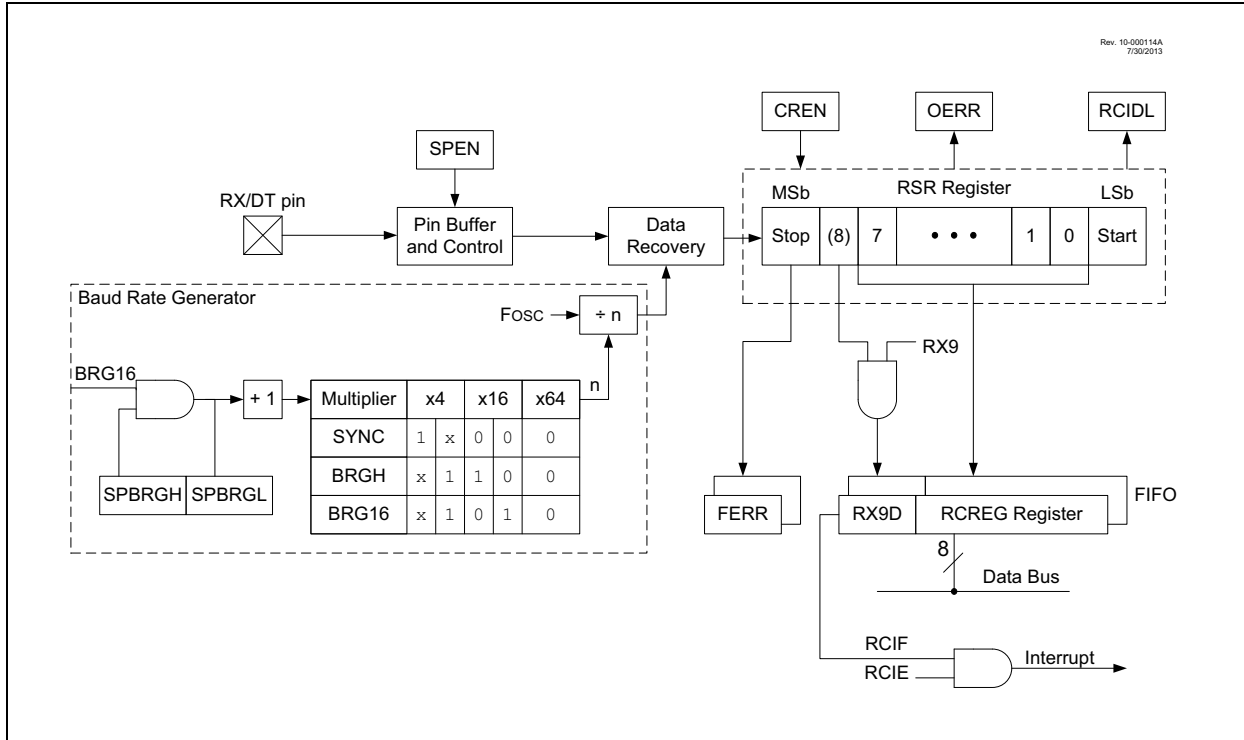

The operation of the EUSART module is controlled through three registers:

- Transmit Status and Control (TXSTA)
- Receive Status and Control (RCSTA)
- Baud Rate Control (BAUDCON)

These registers are detailed in [Register 21-1](#), [Register 21-2](#) and [Register 21-3](#), respectively.

When the receiver or transmitter section is not enabled, then the corresponding RX or TX pin may be used for general purpose input and output.



## 21.1 EUSART Asynchronous Mode

The EUSART transmits and receives data using the standard Non-Return-to-Zero (NRZ) format. NRZ is implemented with two levels: a  $V_{OH}$  mark state which represents a '1' data bit, and a  $V_{OL}$  space state which represents a '0' data bit. NRZ refers to the fact that consecutively transmitted data bits of the same value stay at the output level of that bit without returning to a neutral level between each bit transmission. An NRZ transmission port Idles in the mark state. Each character transmission consists of one Start bit, followed by eight or nine data bits and is always terminated by one or more Stop bits. The Start bit is always a space and the Stop bits are always marks. The most common data format is eight bits. Each transmitted bit persists for a period of  $1/(\text{Baud Rate})$ . An on-chip dedicated 8-bit/16-bit Baud Rate Generator is used to derive standard baud rate frequencies from the system oscillator. See [Table 21-5](#) for examples of baud rate configurations.

The EUSART transmits and receives the LSb first. The EUSART's transmitter and receiver are functionally independent, but share the same data format and baud rate. Parity is not supported by the hardware, but can be implemented in software and stored as the ninth data bit.

### 21.1.1 EUSART ASYNCHRONOUS TRANSMITTER

The EUSART transmitter block diagram is shown in [Figure 21-1](#). The heart of the transmitter is the serial Transmit Shift Register (TSR), which is not directly accessible by software. The TSR obtains its data from the transmit buffer, which is the TXREG register.

#### 21.1.1.1 Enabling the Transmitter

The EUSART transmitter is enabled for asynchronous operations by configuring the following three control bits:

- TXEN = 1
- SYNC = 0
- SPEN = 1

All other EUSART control bits are assumed to be in their default state.

Setting the TXEN bit of the TXSTA register enables the transmitter circuitry of the EUSART. Clearing the SYNC bit of the TXSTA register configures the EUSART for asynchronous operation. Setting the SPEN bit of the RCSTA register enables the EUSART and automatically configures the TX/CK I/O pin as an output. If the TX/CK pin is shared with an analog peripheral, the analog I/O function must be disabled by clearing the corresponding ANSELx bit.

**Note:** The TXIF transmitter interrupt flag is set when the TXEN enable bit is set.

#### 21.1.1.2 Transmitting Data

A transmission is initiated by writing a character to the TXREG register. If this is the first character, or the previous character has been completely flushed from the TSR, the data in the TXREG is immediately transferred to the TSR register. If the TSR still contains all or part of a previous character, the new character data is held in the TXREG until the Stop bit of the previous character has been transmitted. The pending character in the TXREG is then transferred to the TSR in one  $T_{CY}$  immediately following the Stop bit transmission. The transmission of the Start bit, data bits and Stop bit sequence commences immediately following the transfer of the data to the TSR from the TXREG.

#### 21.1.1.3 Transmit Data Polarity

The polarity of the transmit data can be controlled with the SCKP bit of the BAUDCON register. The default state of this bit is '0' which selects high true transmit Idle and data bits. Setting the SCKP bit to '1' will invert the transmit data resulting in low true Idle and data bits. The SCKP bit controls transmit data polarity in Asynchronous mode only. In Synchronous mode, the SCKP bit has a different function. See [Section 21.5.1.2 "Clock Polarity"](#).

#### 21.1.1.4 Transmit Interrupt Flag

The TXIF interrupt flag bit of the PIR1 register is set whenever the EUSART transmitter is enabled and no character is being held for transmission in the TXREG. In other words, the TXIF bit is only clear when the TSR is busy with a character and a new character has been queued for transmission in the TXREG. The TXIF flag bit is not cleared immediately upon writing TXREG. TXIF becomes valid in the second instruction cycle following the write execution. Polling TXIF immediately following the TXREG write will return invalid results. The TXIF bit is read-only, it cannot be set or cleared by software.

The TXIF interrupt can be enabled by setting the TXIE interrupt enable bit of the PIE1 register. However, the TXIF flag bit will be set whenever the TXREG is empty, regardless of the state of the TXIE enable bit.

To use interrupts when transmitting data, set the TXIE bit only when there is more data to send. Clear the TXIE interrupt enable bit upon writing the last character of the transmission to the TXREG.

# PIC12(L)F1571/2

## 21.1.1.5 TSR Status

The TRMT bit of the TXSTA register indicates the status of the TSR register. This is a read-only bit. The TRMT bit is set when the TSR register is empty and is cleared when a character is transferred to the TSR register from the TXREG. The TRMT bit remains clear until all bits have been shifted out of the TSR register. No interrupt logic is tied to this bit, so the user has to poll this bit to determine the TSR status.

**Note:** The TSR register is not mapped in data memory, so it is not available to the user.

## 21.1.1.6 Transmitting 9-Bit Characters

The EUSART supports 9-bit character transmissions. When the TX9 bit of the TXSTA register is set, the EUSART will shift nine bits out for each character transmitted. The TX9D bit of the TXSTA register is the ninth and Most Significant data bit. When transmitting 9-bit data, the TX9D data bit must be written before writing the eight Least Significant bits into the TXREG. All nine bits of data will be transferred to the TSR register immediately after the TXREG is written.

A special 9-Bit Address mode is available for use with multiple receivers. See [Section 21.1.2.7 “Address Detection”](#) for more information on this mode.

## 21.1.1.7 Asynchronous Transmission Setup

1. Initialize the SPBRGH/SPBRGL register pair, and the BRGH and BRG16 bits to achieve the desired baud rate (see [Section 21.4 “EUSART Baud Rate Generator \(BRG\)”](#)).
2. Enable the asynchronous serial port by clearing the SYNC bit and setting the SPEN bit.
3. If 9-bit transmission is desired, set the TX9 control bit. A set ninth data bit will indicate that the eight Least Significant data bits are an address when the receiver is set for address detection.
4. Set the SCKP bit if inverted transmit is desired.
5. Enable the transmission by setting the TXEN control bit. This will cause the TXIF interrupt bit to be set.
6. If interrupts are desired, set the TXIE interrupt enable bit of the PIE1 register. An interrupt will occur immediately provided that the GIE and PEIE bits of the INTCN register are also set.
7. If 9-bit transmission is selected, the ninth bit should be loaded into the TX9D data bit.
8. Load 8-bit data into the TXREG register. This will start the transmission.

**FIGURE 21-3: ASYNCHRONOUS TRANSMISSION**

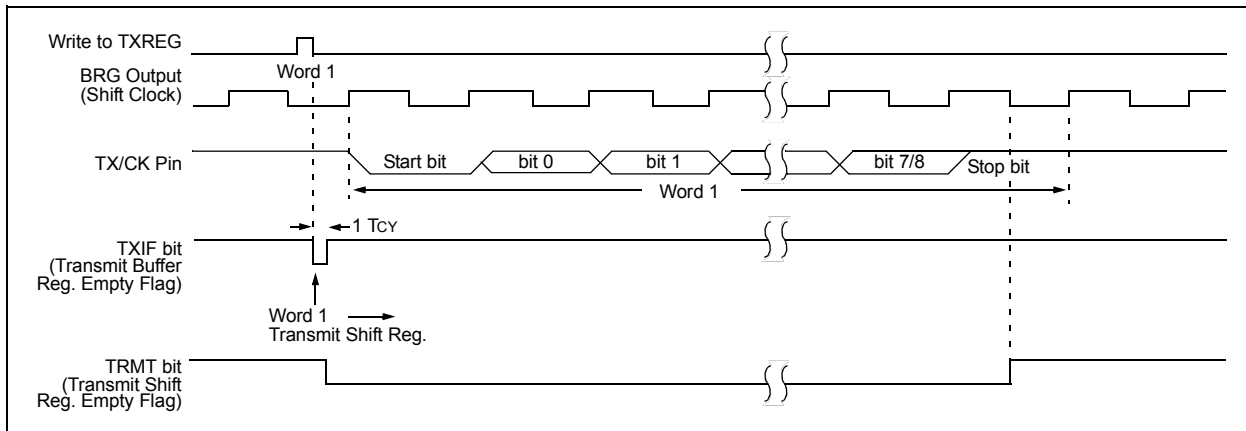

**FIGURE 21-4: ASYNCHRONOUS TRANSMISSION (BACK-TO-BACK)**

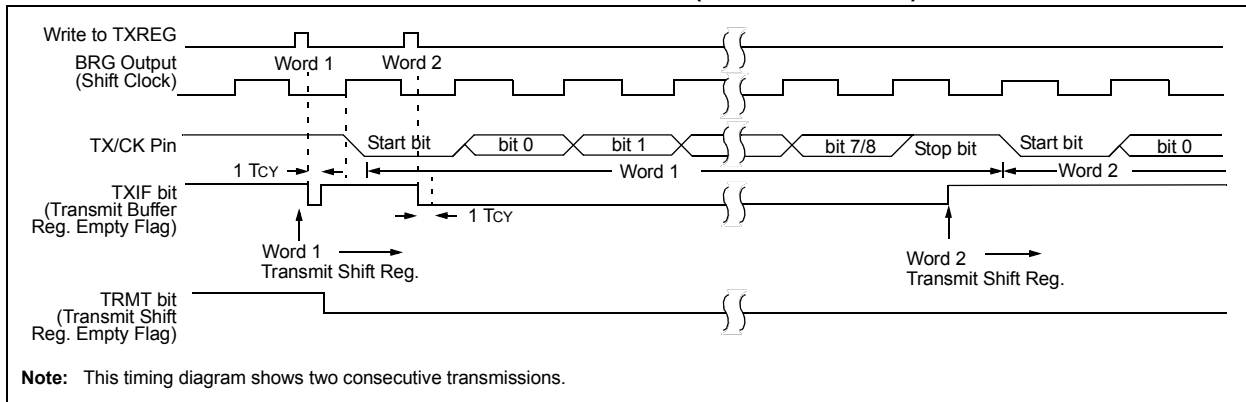

**Note:** This timing diagram shows two consecutive transmissions.

**TABLE 21-1: SUMMARY OF REGISTERS ASSOCIATED WITH ASYNCHRONOUS TRANSMISSION**

Name	Bit 7	Bit 6	Bit 5	Bit 4	Bit 3	Bit 2	Bit 1	Bit 0	Register on Page
BAUDCON	ABDOVF	RCIDL	—	SCKP	BRG16	—	WUE	ABDEN	186
INTCON	GIE	PEIE	TMR0IE	INTE	IOCIE	TMR0IF	INTF	IOCIF	74
PIE1	TMR1GIE	ADIE	RCIE <sup>(1)</sup>	TXIE <sup>(1)</sup>	—	—	TMR2IE	TMR1IE	75
PIR1	TMR1GIF	ADIF	RCIF <sup>(1)</sup>	TXIF <sup>(1)</sup>	—	—	TMR2IF	TMR1IF	78
RCSTA	SPEN	RX9	SREN	CREN	ADDEN	FERR	OERR	RX9D	185*
SPBRGL	BRG<7:0>								187*
SPBRGH	BRG<15:8>								187*
TXREG	EUSART Transmit Data Register								177
TXSTA	CSRC	TX9	TXEN	SYNC	SENDER	BRGH	TRMT	TX9D	184

**Legend:** — = unimplemented location, read as '0'. Shaded cells are not used for asynchronous transmission.

\* Page provides register information.

**Note 1:** PIC12(L)F1572 only.

# PIC12(L)F1571/2

## 21.1.2 EUSART ASYNCHRONOUS RECEIVER

The Asynchronous mode is typically used in RS-232 systems. The receiver block diagram is shown in [Figure 21-2](#). The data is received on the RX/DT pin and drives the data recovery block. The data recovery block is actually a high-speed shifter operating at 16 times the baud rate, whereas the serial Receive Shift Register (RSR) operates at the bit rate. When all eight or nine bits of the character have been shifted in, they are immediately transferred to a two character First-In-First-Out (FIFO) memory. The FIFO buffering allows reception of two complete characters and the start of a third character before software must start servicing the EUSART receiver. The FIFO and RSR registers are not directly accessible by software. Access to the received data is via the RCREG register.

### 21.1.2.1 Enabling the Receiver

The EUSART receiver is enabled for asynchronous operation by configuring the following three control bits:

- CREN = 1
- SYNC = 0
- SPEN = 1

All other EUSART control bits are assumed to be in their default state.

Setting the CREN bit of the RCSTA register enables the receiver circuitry of the EUSART. Clearing the SYNC bit of the TXSTA register configures the EUSART for asynchronous operation. Setting the SPEN bit of the RCSTA register enables the EUSART. The programmer must set the corresponding TRIS bit to configure the RX/DT I/O pin as an input.

**Note:** If the RX/DT function is on an analog pin, the corresponding ANSELx bit must be cleared for the receiver to function.

### 21.1.2.2 Receiving Data

The receiver data recovery circuit initiates character reception on the falling edge of the first bit. The first bit, also known as the Start bit, is always a zero. The data recovery circuit counts one-half bit time to the center of the Start bit and verifies that the bit is still a zero. If it is not a zero then the data recovery circuit aborts character reception, without generating an error, and resumes looking for the falling edge of the Start bit. If the Start bit zero verification succeeds, then the data recovery circuit counts a full bit time to the center of the next bit. The bit is then sampled by a majority detect circuit and the resulting '0' or '1' is shifted into the RSR. This repeats until all data bits have been sampled and shifted into the RSR. One final bit time is measured and the level sampled. This is the Stop bit, which is always a '1'. If the data recovery circuit samples a '0' in the Stop bit position then a framing error is set for this character; otherwise, the framing error is cleared for this character. See [Section 21.1.2.4 "Receive Framing Error"](#) for more information on framing errors.

Immediately after all data bits and the Stop bit have been received, the character in the RSR is transferred to the EUSART receive FIFO and the RCIF interrupt flag bit of the PIR1 register is set. The top character in the FIFO is transferred out of the FIFO by reading the RCREG register.

**Note:** If the receive FIFO is overrun, no additional characters will be received until the overrun condition is cleared. See [Section 21.1.2.5 "Receive Overrun Error"](#) for more information on overrun errors.

### 21.1.2.3 Receive Interrupts

The RCIF interrupt flag bit of the PIR1 register is set whenever the EUSART receiver is enabled and there is an unread character in the receive FIFO. The RCIF interrupt flag bit is read-only, it cannot be set or cleared by software.

RCIF interrupts are enabled by setting all of the following bits:

- RCIE, Interrupt Enable bit of the PIE1 register
- PEIE, Peripheral Interrupt Enable bit of the INTCON register
- GIE, Global Interrupt Enable bit of the INTCON register

The RCIF interrupt flag bit will be set when there is an unread character in the FIFO, regardless of the state of interrupt enable bits.

## 21.1.2.4 Receive Framing Error

Each character in the receive FIFO buffer has a corresponding framing error status bit. A framing error indicates that a Stop bit was not seen at the expected time. The framing error status is accessed via the FERR bit of the RCSTA register. The FERR bit represents the status of the top unread character in the receive FIFO. Therefore, the FERR bit must be read before reading the RCREG.

The FERR bit is read-only and only applies to the top unread character in the receive FIFO. A framing error (FERR = 1) does not preclude reception of additional characters. It is not necessary to clear the FERR bit. Reading the next character from the FIFO buffer will advance the FIFO to the next character and the next corresponding framing error.

The FERR bit can be forced clear by clearing the SPEN bit of the RCSTA register which resets the EUSART. Clearing the CREN bit of the RCSTA register does not affect the FERR bit. A framing error by itself does not generate an interrupt.

<b>Note:</b> If all receive characters in the receive FIFO have framing errors, repeated reads of the RCREG will not clear the FERR bit.
--

## 21.1.2.5 Receive Overrun Error

The receive FIFO buffer can hold two characters. An overrun error will be generated if a third character, in its entirety, is received before the FIFO is accessed. When this happens the OERR bit of the RCSTA register is set. The characters already in the FIFO buffer can be read, but no additional characters will be received until the error is cleared. The error must be cleared by either clearing the CREN bit of the RCSTA register or by resetting the EUSART by clearing the SPEN bit of the RCSTA register.

## 21.1.2.6 Receiving 9-Bit Characters

The EUSART supports 9-bit character reception. When the RX9 bit of the RCSTA register is set, the EUSART will shift nine bits into the RSR for each character received. The RX9D bit of the RCSTA register is the ninth and Most Significant data bit of the top unread character in the receive FIFO. When reading 9-bit data from the receive FIFO buffer, the RX9D data bit must be read before reading the eight Least Significant bits from the RCREG.

## 21.1.2.7 Address Detection

A special Address Detection mode is available for use when multiple receivers share the same transmission line, such as in RS-485 systems. Address detection is enabled by setting the ADDEN bit of the RCSTA register.

Address detection requires 9-bit character reception. When address detection is enabled, only characters with the ninth data bit set will be transferred to the receive FIFO buffer, thereby setting the RCIF interrupt bit. All other characters will be ignored.

Upon receiving an address character, user software determines if the address matches its own. Upon address match, user software must disable address detection by clearing the ADDEN bit before the next Stop bit occurs. When user software detects the end of the message, determined by the message protocol used, software places the receiver back into the Address Detection mode by setting the ADDEN bit.

# PIC12(L)F1571/2

## 21.1.2.8 Asynchronous Reception Setup

1. Initialize the SPBRGH, SPBRGL register pair and the BRGH and BRG16 bits to achieve the desired baud rate (see [Section 21.4 “EUSART Baud Rate Generator \(BRG\)”](#)).
2. Clear the ANSELx bit for the RX pin (if applicable).
3. Enable the serial port by setting the SPEN bit. The SYNC bit must be clear for asynchronous operation.
4. If interrupts are desired, set the RCIE bit of the PIE1 register, and the GIE and PEIE bits of the INTCON register.
5. If 9-bit reception is desired, set the RX9 bit.
6. Enable reception by setting the CREN bit.
7. The RCIF interrupt flag bit will be set when a character is transferred from the RSR to the receive buffer. An interrupt will be generated if the RCIE interrupt enable bit was also set.
8. Read the RCSTA register to get the error flags and, if 9-bit data reception is enabled, the ninth data bit.
9. Get the received eight Least Significant data bits from the receive buffer by reading the RCREG register.
10. If an overrun occurred, clear the OERR flag by clearing the CREN receiver enable bit.

## 21.1.2.9 9-Bit Address Detection Mode Setup

This mode would typically be used in RS-485 systems. To set up an Asynchronous Reception with Address Detect Enable:

1. Initialize the SPBRGH/SPBRGL register pair, and the BRGH and BRG16 bits to achieve the desired baud rate (see [Section 21.4 “EUSART Baud Rate Generator \(BRG\)”](#)).
2. Clear the ANSELx bit for the RX pin (if applicable).
3. Enable the serial port by setting the SPEN bit. The SYNC bit must be clear for asynchronous operation.
4. If interrupts are desired, set the RCIE bit of the PIE1 register, and the GIE and PEIE bits of the INTCON register.
5. Enable 9-bit reception by setting the RX9 bit.
6. Enable address detection by setting the ADDEN bit.
7. Enable reception by setting the CREN bit.
8. The RCIF interrupt flag bit will be set when a character with the ninth bit set is transferred from the RSR to the receive buffer. An interrupt will be generated if the RCIE interrupt enable bit was also set.
9. Read the RCSTA register to get the error flags. The ninth data bit will always be set.
10. Get the received eight Least Significant data bits from the receive buffer by reading the RCREG register. Software determines if this is the device's address.
11. If an overrun occurred, clear the OERR flag by clearing the CREN receiver enable bit.
12. If the device has been addressed, clear the ADDEN bit to allow all received data into the receive buffer and generate interrupts.

**FIGURE 21-5: ASYNCHRONOUS RECEPTION**

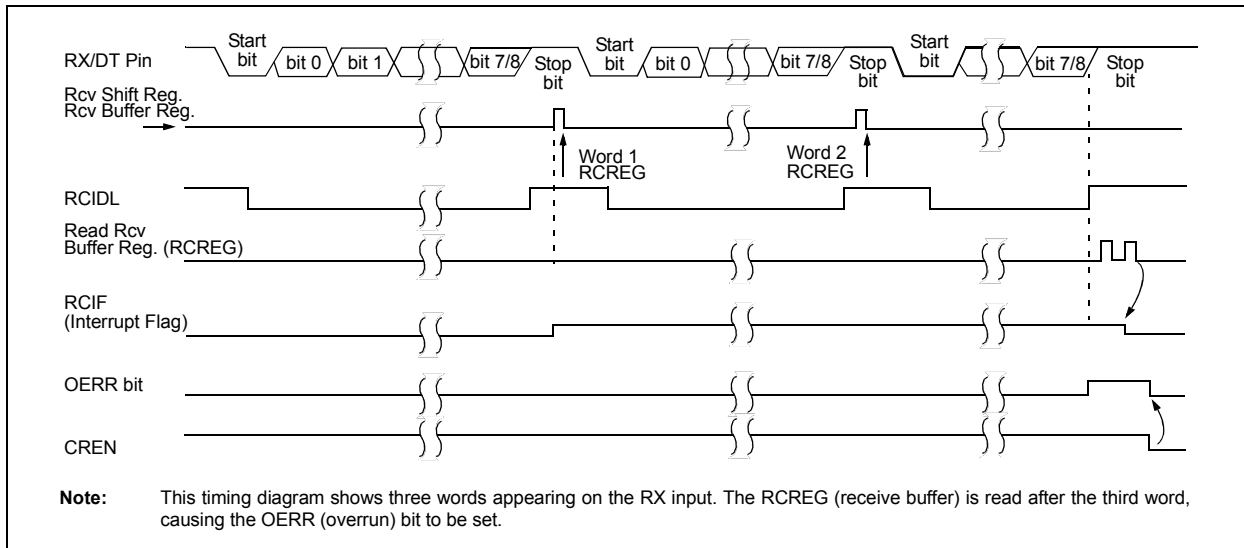

**TABLE 21-2: SUMMARY OF REGISTERS ASSOCIATED WITH ASYNCHRONOUS RECEPTION**

Name	Bit 7	Bit 6	Bit 5	Bit 4	Bit 3	Bit 2	Bit 1	Bit 0	Register on Page
BAUDCON	ABDOVF	RCIDL	—	SCKP	BRG16	—	WUE	ABDEN	186
INTCON	GIE	PEIE	TMR0IE	INTE	IOCFIE	TMR0IF	INTF	IOCFIF	74
PIE1	TMR1GIE	ADIE	RCIE <sup>(1)</sup>	TXIE <sup>(1)</sup>	—	—	TMR2IE	TMR1IE	75
PIR1	TMR1GIF	ADIF	RCIF <sup>(1)</sup>	TXIF <sup>(1)</sup>	—	—	TMR2IF	TMR1IF	78
RCREG	EUSART Receive Data Register								180*
RCSTA	SPEN	RX9	SREN	CREN	ADDEN	FERR	OERR	RX9D	185*
SPBRGL	BRG<7:0>								187*
SPBRGH	BRG<15:8>								187*
TXSTA	CSRC	TX9	TXEN	SYNC	SEnDB	BRGH	TRMT	TX9D	184

**Legend:** — = unimplemented location, read as '0'. Shaded cells are not used for asynchronous reception.

\* Page provides register information.

**Note 1:** PIC12(L)F1572 only.

## 21.2 Clock Accuracy with Asynchronous Operation

The factory calibrates the Internal Oscillator Block (INTOSC) output. However, the INTOSC frequency may drift as V<sub>DD</sub> or temperature changes, and this directly affects the asynchronous baud rate.

The Auto-Baud Detect feature (see [Section 21.4.1 “Auto-Baud Detect”](#)) can be used to compensate for changes in the INTOSC frequency.

There may not be fine enough resolution when adjusting the Baud Rate Generator to compensate for a gradual change in the peripheral clock frequency.

# PIC12(L)F1571/2

## 21.3 Register Definitions: EUSART Control

### REGISTER 21-1: TXSTA: TRANSMIT STATUS AND CONTROL REGISTER

R/W-/0	R/W-0/0	R/W-0/0	R/W-0/0	R/W-0/0	R/W-0/0	R-1/1	R/W-0/0
CSRC	TX9	TXEN <sup>(1)</sup>	SYNC	SENDB	BRGH	TRMT	TX9D
bit 7							bit 0

#### Legend:

R = Readable bit

W = Writable bit

u = Bit is unchanged

x = Bit is unknown

U = Unimplemented bit, read as '0'

'1' = Bit is set

'0' = Bit is cleared

-n/n = Value at POR and BOR/Value at all other Resets

- bit 7      **CSRC:** Clock Source Select bit  
Asynchronous mode:  
Don't care.  
Synchronous mode:  
1 = Master mode (clock generated internally from BRG)  
0 = Slave mode (clock from external source)
- bit 6      **TX9:** 9-Bit Transmit Enable bit  
1 = Selects 9-bit transmission  
0 = Selects 8-bit transmission
- bit 5      **TXEN:** Transmit Enable bit<sup>(1)</sup>  
1 = Transmit is enabled  
0 = Transmit is disabled
- bit 4      **SYNC:** EUSART Mode Select bit  
1 = Synchronous mode  
0 = Asynchronous mode
- bit 3      **SENDB:** Send Break Character bit  
Asynchronous mode:  
1 = Sends Sync Break on next transmission (cleared by hardware upon completion)  
0 = Sync Break transmission completed  
Synchronous mode:  
Don't care.
- bit 2      **BRGH:** High Baud Rate Select bit  
Asynchronous mode:  
1 = High speed  
0 = Low speed  
Synchronous mode:  
Unused in this mode.
- bit 1      **TRMT:** Transmit Shift Register Status bit  
1 = TSR is empty  
0 = TSR is full
- bit 0      **TX9D:** Ninth bit of Transmit Data  
Can be address/data bit or a parity bit.

**Note 1:** SREN/CREN overrides TXEN in Sync mode.



## REGISTER 21-2: RCSTA: RECEIVE STATUS AND CONTROL REGISTER

R/W-0/0	R/W-0/0	R/W-0/0	R/W-0/0	R/W-0/0	R-0/0	R-0/0	R-0/0
SPEN	RX9	SREN	CREN	ADDEN	FERR	OERR	RX9D
bit 7							bit 0

### Legend:

R = Readable bit	W = Writable bit	
u = Bit is unchanged	x = Bit is unknown	U = Unimplemented bit, read as '0'
'1' = Bit is set	'0' = Bit is cleared	-n/n = Value at POR and BOR/Value at all other Resets

- bit 7      **SPEN:** Serial Port Enable bit  
1 = Serial port is enabled (configures RX/DT and TX/CK pins as serial port pins)  
0 = Serial port is disabled (held in Reset)
- bit 6      **RX9:** 9-Bit Receive Enable bit  
1 = Selects 9-bit reception  
0 = Selects 8-bit reception
- bit 5      **SREN:** Single Receive Enable bit  
Asynchronous mode:  
Don't care.  
Synchronous mode – Master:  
1 = Enables single receive  
0 = Disables single receive  
This bit is cleared after reception is complete.  
Synchronous mode – Slave:  
Don't care.
- bit 4      **CREN:** Continuous Receive Enable bit  
Asynchronous mode:  
1 = Enables receiver  
0 = Disables receiver  
Synchronous mode:  
1 = Enables continuous receive until enable bit CREN is cleared (CREN overrides SREN)  
0 = Disables continuous receive
- bit 3      **ADDEN:** Address Detect Enable bit  
Asynchronous mode 9-bit (RX9 = 1):  
1 = Enables address detection, enables interrupt and loads the receive buffer when RSR<8> is set  
0 = Disables address detection, all bytes are received and ninth bit can be used as parity bit  
Asynchronous mode 8-bit (RX9 = 0):  
Don't care.
- bit 2      **FERR:** Framing Error bit  
1 = Framing error (can be updated by reading RCREG register and receiving next valid byte)  
0 = No framing error
- bit 1      **OERR:** Overrun Error bit  
1 = Overrun error (can be cleared by clearing bit, CREN)  
0 = No overrun error
- bit 0      **RX9D:** Ninth Bit of Received Data bit  
This can be address/data bit or a parity bit and must be calculated by user firmware.

# PIC12(L)F1571/2

## REGISTER 21-3: BAUDCON: BAUD RATE CONTROL REGISTER

R-0/0	R-1/1	U-0	R/W-0/0	R/W-0/0	U-0	R/W-0/0	R/W-0/0
ABDOVF	RCIDL	—	SCKP	BRG16	—	WUE	ABDEN
bit 7							bit 0

### Legend:

R = Readable bit                      W = Writable bit  
u = Bit is unchanged                  x = Bit is unknown                  U = Unimplemented bit, read as '0'  
'1' = Bit is set                          '0' = Bit is cleared                  -n/n = Value at POR and BOR/Value at all other Resets

- bit 7            **ABDOVF**: Auto-Baud Detect Overflow bit  
Asynchronous mode:  
1 = Auto-baud timer overflowed  
0 = Auto-baud timer did not overflow  
Synchronous mode:  
Don't care.
- bit 6            **RCIDL**: Receive Idle Flag bit  
Asynchronous mode:  
1 = Receiver is Idle  
0 = Start bit has been received and the receiver is receiving  
Synchronous mode:  
Don't care.
- bit 5            **Unimplemented**: Read as '0'
- bit 4            **SCKP**: Synchronous Clock Polarity Select bit  
Asynchronous mode:  
1 = Transmits inverted data to the TX/CK pin  
0 = Transmits non-inverted data to the TX/CK pin  
Synchronous mode:  
1 = Data is clocked on rising edge of the clock  
0 = Data is clocked on falling edge of the clock
- bit 3            **BRG16**: 16-Bit Baud Rate Generator bit  
1 = 16-bit Baud Rate Generator is used  
0 = 8-bit Baud Rate Generator is used
- bit 2            **Unimplemented**: Read as '0'
- bit 1            **WUE**: Wake-up Enable bit  
Asynchronous mode:  
1 = Receiver is waiting for a falling edge; no character will be received, RCIF bit will be set, WUE will automatically clear after RCIF is set  
0 = Receiver is operating normally  
Synchronous mode:  
Don't care.
- bit 0            **ABDEN**: A.uto-Baud Detect Enable bit  
Asynchronous mode:  
1 = Auto-Baud Detect mode is enabled (clears when auto-baud is complete)  
0 = Auto-Baud Detect mode is disabled  
Synchronous mode:  
Don't care.

## 21.4 EUSART Baud Rate Generator (BRG)

The Baud Rate Generator (BRG) is an 8-bit or 16-bit timer that is dedicated to the support of both the asynchronous and synchronous EUSART operation. By default, the BRG operates in 8-bit mode. Setting the BRG16 bit of the BAUDCON register selects 16-bit mode.

The SPBRGH/SPBRGL register pair determines the period of the free-running baud rate timer. In Asynchronous mode, the multiplier of the baud rate period is determined by both the BRGH bit of the TXSTA register and the BRG16 bit of the BAUDCON register. In Synchronous mode, the BRGH bit is ignored.

Table 21-3 contains the formulas for determining the baud rate. Example 21-1 provides a sample calculation for determining the baud rate and baud rate error.

Typical baud rates and error values for various Asynchronous modes have been computed for your convenience and are shown in Table 21-3. It may be advantageous to use the high baud rate (BRGH = 1) or the 16-bit BRG (BRG16 = 1) to reduce the baud rate error. The 16-bit BRG mode is used to achieve slow baud rates for fast oscillator frequencies.

Writing a new value to the SPBRGH/SPBRGL register pair causes the BRG timer to be reset (or cleared). This ensures that the BRG does not wait for a timer overflow before outputting the new baud rate.

If the system clock is changed during an active receive operation, a receive error or data loss may result. To avoid this problem, check the status of the RCIDL bit to make sure that the receive operation is Idle before changing the system clock.

### EXAMPLE 21-1: CALCULATING BAUD RATE ERROR

For a device with Fosc of 16 MHz, desired baud rate of 9600, Asynchronous mode, 8-bit BRG:

$$\text{Desired Baud Rate} = \frac{F_{osc}}{64(SPBRGH:SPBRGL + 1)}$$

Solving for SPBRGH:SPBRGL:

$$X = \frac{F_{osc}}{\text{Desired Baud Rate} \cdot 64} - 1$$

$$= \frac{16000000}{9600 \cdot 64} - 1$$

$$= [25.042] = 25$$

$$\text{Calculated Baud Rate} = \frac{16000000}{64(25 + 1)}$$

$$= 9615$$

$$\text{Error} = \frac{\text{Calc. Baud Rate} - \text{Desired Baud Rate}}{\text{Desired Baud Rate}}$$

$$= \frac{(9615 - 9600)}{9600} = 0.16\%$$

# PIC12(L)F1571/2

**TABLE 21-3: BAUD RATE FORMULAS**

Configuration Bits			BRG/EUSART Mode	Baud Rate Formula
SYNC	BRG16	BRGH		
0	0	0	8-bit/Asynchronous	$F_{osc}/[64(n+1)]$
0	0	1	8-bit/Asynchronous	$F_{osc}/[16(n+1)]$
0	1	0	16-bit/Asynchronous	
0	1	1	16-bit/Asynchronous	$F_{osc}/[4(n+1)]$
1	0	x	8-bit/Synchronous	
1	1	x	16-bit/Synchronous	

**Legend:** x = Don't care; n = value of SPBRGH/SPBRGL register pair.

**TABLE 21-4: SUMMARY OF REGISTERS ASSOCIATED WITH THE BAUD RATE GENERATOR**

Name	Bit 7	Bit 6	Bit 5	Bit 4	Bit 3	Bit 2	Bit 1	Bit 0	Register on Page
BAUDCON	ABDOVF	RCIDL	—	SCKP	BRG16	—	WUE	ABDEN	186
RCSTA	SPEN	RX9	SREN	CREN	ADDEN	FERR	OERR	RX9D	185
SPBRGL	BRG<7:0>								187*
SPBRGH	BRG<15:8>								187*
TXSTA	CSRC	TX9	TXEN	SYNC	SENDB	BRGH	TRMT	TX9D	184

**Legend:** — = unimplemented location, read as '0'. Shaded cells are not used for the Baud Rate Generator.

\* Page provides register information.

**TABLE 21-5: BAUD RATES FOR ASYNCHRONOUS MODES**

BAUD RATE	SYNC = 0, BRGH = 0, BRG16 = 0											
	Fosc = 20.000 MHz			Fosc = 18.432 MHz			Fosc = 16.000 MHz			Fosc = 11.0592 MHz		
	Actual Rate	% Error	SPBRG Value (decimal)	Actual Rate	% Error	SPBRG Value (decimal)	Actual Rate	% Error	SPBRG Value (decimal)	Actual Rate	% Error	SPBRG Value (decimal)
300	—	—	—	—	—	—	—	—	—	—	—	—
1200	1221	1.73	255	1200	0.00	239	1202	0.16	207	1200	0.00	143
2400	2404	0.16	129	2400	0.00	119	2404	0.16	103	2400	0.00	71
9600	9470	-1.36	32	9600	0.00	29	9615	0.16	25	9600	0.00	17
10417	10417	0.00	29	10286	-1.26	27	10417	0.00	23	10165	-2.42	16
19.2k	19.53k	1.73	15	19.20k	0.00	14	19.23k	0.16	12	19.20k	0.00	8
57.6k	—	—	—	57.60k	0.00	7	—	—	—	57.60k	0.00	2
115.2k	—	—	—	—	—	—	—	—	—	—	—	—

BAUD RATE	SYNC = 0, BRGH = 0, BRG16 = 0											
	Fosc = 8.000 MHz			Fosc = 4.000 MHz			Fosc = 3.6864 MHz			Fosc = 1.000 MHz		
	Actual Rate	% Error	SPBRG Value (decimal)	Actual Rate	% Error	SPBRG Value (decimal)	Actual Rate	% Error	SPBRG Value (decimal)	Actual Rate	% Error	SPBRG Value (decimal)
300	—	—	—	300	0.16	207	300	0.00	191	300	0.16	51
1200	1202	0.16	103	1202	0.16	51	1200	0.00	47	1202	0.16	12
2400	2404	0.16	51	2404	0.16	25	2400	0.00	23	—	—	—
9600	9615	0.16	12	—	—	—	9600	0.00	5	—	—	—
10417	10417	0.00	11	10417	0.00	5	—	—	—	—	—	—
19.2k	—	—	—	—	—	—	19.20k	0.00	2	—	—	—
57.6k	—	—	—	—	—	—	57.60k	0.00	0	—	—	—
115.2k	—	—	—	—	—	—	—	—	—	—	—	—

BAUD RATE	SYNC = 0, BRGH = 1, BRG16 = 0											
	Fosc = 20.000 MHz			Fosc = 18.432 MHz			Fosc = 16.000 MHz			Fosc = 11.0592 MHz		
	Actual Rate	% Error	SPBRG Value (decimal)	Actual Rate	% Error	SPBRG Value (decimal)	Actual Rate	% Error	SPBRG Value (decimal)	Actual Rate	% Error	SPBRG Value (decimal)
300	—	—	—	—	—	—	—	—	—	—	—	—
1200	—	—	—	—	—	—	—	—	—	—	—	—
2400	—	—	—	—	—	—	—	—	—	—	—	—
9600	9615	0.16	129	9600	0.00	119	9615	0.16	103	9600	0.00	71
10417	10417	0.00	119	10378	-0.37	110	10417	0.00	95	10473	0.53	65
19.2k	19.23k	0.16	64	19.20k	0.00	59	19.23k	0.16	51	19.20k	0.00	35
57.6k	56.82k	-1.36	21	57.60k	0.00	19	58.82k	2.12	16	57.60k	0.00	11
115.2k	113.64k	-1.36	10	115.2k	0.00	9	111.1k	-3.55	8	115.2k	0.00	5

# PIC12(L)F1571/2

**TABLE 21-5: BAUD RATES FOR ASYNCHRONOUS MODES (CONTINUED)**

BAUD RATE	SYNC = 0, BRGH = 1, BRG16 = 0											
	Fosc = 8.000 MHz			Fosc = 4.000 MHz			Fosc = 3.6864 MHz			Fosc = 1.000 MHz		
	Actual Rate	% Error	SPBRG Value (decimal)	Actual Rate	% Error	SPBRG Value (decimal)	Actual Rate	% Error	SPBRG Value (decimal)	Actual Rate	% Error	SPBRG Value (decimal)
300	—	—	—	—	—	—	—	—	—	300	0.16	207
1200	—	—	—	1202	0.16	207	1200	0.00	191	1202	0.16	51
2400	2404	0.16	207	2404	0.16	103	2400	0.00	95	2404	0.16	25
9600	9615	0.16	51	9615	0.16	25	9600	0.00	23	—	—	—
10417	10417	0.00	47	10417	0.00	23	10473	0.53	21	10417	0.00	5
19.2k	19231	0.16	25	19.23k	0.16	12	19.2k	0.00	11	—	—	—
57.6k	55556	-3.55	8	—	—	—	57.60k	0.00	3	—	—	—
115.2k	—	—	—	—	—	—	115.2k	0.00	1	—	—	—

BAUD RATE	SYNC = 0, BRGH = 0, BRG16 = 1											
	Fosc = 20.000 MHz			Fosc = 18.432 MHz			Fosc = 16.000 MHz			Fosc = 11.0592 MHz		
	Actual Rate	% Error	SPBRG Value (decimal)	Actual Rate	% Error	SPBRG Value (decimal)	Actual Rate	% Error	SPBRG Value (decimal)	Actual Rate	% Error	SPBRG Value (decimal)
300	300.0	-0.01	4166	300.0	0.00	3839	300.03	0.01	3332	300.0	0.00	2303
1200	1200	-0.03	1041	1200	0.00	959	1200.5	0.04	832	1200	0.00	575
2400	2399	-0.03	520	2400	0.00	479	2398	-0.08	416	2400	0.00	287
9600	9615	0.16	129	9600	0.00	119	9615	0.16	103	9600	0.00	71
10417	10417	0.00	119	10378	-0.37	110	10417	0.00	95	10473	0.53	65
19.2k	19.23k	0.16	64	19.20k	0.00	59	19.23k	0.16	51	19.20k	0.00	35
57.6k	56.818	-1.36	21	57.60k	0.00	19	58.82k	2.12	16	57.60k	0.00	11
115.2k	113.636	-1.36	10	115.2k	0.00	9	111.11k	-3.55	8	115.2k	0.00	5

BAUD RATE	SYNC = 0, BRGH = 0, BRG16 = 1											
	Fosc = 8.000 MHz			Fosc = 4.000 MHz			Fosc = 3.6864 MHz			Fosc = 1.000 MHz		
	Actual Rate	% Error	SPBRG Value (decimal)	Actual Rate	% Error	SPBRG Value (decimal)	Actual Rate	% Error	SPBRG Value (decimal)	Actual Rate	% Error	SPBRG Value (decimal)
300	299.9	-0.02	1666	300.1	0.04	832	300.0	0.00	767	300.5	0.16	207
1200	1199	-0.08	416	1202	0.16	207	1200	0.00	191	1202	0.16	51
2400	2404	0.16	207	2404	0.16	103	2400	0.00	95	2404	0.16	25
9600	9615	0.16	51	9615	0.16	25	9600	0.00	23	—	—	—
10417	10417	0.00	47	10417	0.00	23	10473	0.53	21	10417	0.00	5
19.2k	19.23k	0.16	25	19.23k	0.16	12	19.20k	0.00	11	—	—	—
57.6k	55556	-3.55	8	—	—	—	57.60k	0.00	3	—	—	—
115.2k	—	—	—	—	—	—	115.2k	0.00	1	—	—	—

**TABLE 21-5: BAUD RATES FOR ASYNCHRONOUS MODES (CONTINUED)**

BAUD RATE	SYNC = 0, BRGH = 1, BRG16 = 1 or SYNC = 1, BRG16 = 1											
	Fosc = 20.000 MHz			Fosc = 18.432 MHz			Fosc = 16.000 MHz			Fosc = 11.0592 MHz		
	Actual Rate	% Error	SPBRG Value (decimal)	Actual Rate	% Error	SPBRG Value (decimal)	Actual Rate	% Error	SPBRG Value (decimal)	Actual Rate	% Error	SPBRG Value (decimal)
300	300.0	0.00	16665	300.0	0.00	15359	300.0	0.00	13332	300.0	0.00	9215
1200	1200	-0.01	4166	1200	0.00	3839	1200.1	0.01	3332	1200	0.00	2303
2400	2400	0.02	2082	2400	0.00	1919	2399.5	-0.02	1666	2400	0.00	1151
9600	9597	-0.03	520	9600	0.00	479	9592	-0.08	416	9600	0.00	287
10417	10417	0.00	479	10425	0.08	441	10417	0.00	383	10433	0.16	264
19.2k	19.23k	0.16	259	19.20k	0.00	239	19.23k	0.16	207	19.20k	0.00	143
57.6k	57.47k	-0.22	86	57.60k	0.00	79	57.97k	0.64	68	57.60k	0.00	47
115.2k	116.3k	0.94	42	115.2k	0.00	39	114.29k	-0.79	34	115.2k	0.00	23

BAUD RATE	SYNC = 0, BRGH = 1, BRG16 = 1 or SYNC = 1, BRG16 = 1											
	Fosc = 8.000 MHz			Fosc = 4.000 MHz			Fosc = 3.6864 MHz			Fosc = 1.000 MHz		
	Actual Rate	% Error	SPBRG Value (decimal)	Actual Rate	% Error	SPBRG Value (decimal)	Actual Rate	% Error	SPBRG Value (decimal)	Actual Rate	% Error	SPBRG Value (decimal)
300	300.0	0.00	6666	300.0	0.01	3332	300.0	0.00	3071	300.1	0.04	832
1200	1200	-0.02	1666	1200	0.04	832	1200	0.00	767	1202	0.16	207
2400	2401	0.04	832	2398	0.08	416	2400	0.00	383	2404	0.16	103
9600	9615	0.16	207	9615	0.16	103	9600	0.00	95	9615	0.16	25
10417	10417	0	191	10417	0.00	95	10473	0.53	87	10417	0.00	23
19.2k	19.23k	0.16	103	19.23k	0.16	51	19.20k	0.00	47	19.23k	0.16	12
57.6k	57.14k	-0.79	34	58.82k	2.12	16	57.60k	0.00	15	—	—	—
115.2k	117.6k	2.12	16	111.1k	-3.55	8	115.2k	0.00	7	—	—	—

# PIC12(L)F1571/2

## 21.4.1 AUTO-BAUD DETECT

The EUSART module supports automatic detection and calibration of the baud rate.

In the Auto-Baud Detect (ABD) mode, the clock to the BRG is reversed. Rather than the BRG clocking the incoming RX signal, the RX signal is timing the BRG. The Baud Rate Generator is used to time the period of a received 55h (ASCII “U”), which is the Sync character for the LIN bus. The unique feature of this character is that it has five rising edges, including the Stop bit edge.

Setting the ABDEN bit of the BAUDCON register starts the auto-baud calibration sequence (Figure 21-6). While the ABD sequence takes place, the EUSART state machine is held in Idle. On the first rising edge of the receive line, after the Start bit, the SPBRG begins counting up using the BRG counter clock as shown in Table 21-6. The fifth rising edge will occur on the RX pin at the end of the eighth bit period. At that time, an accumulated value totaling the proper BRG period is left in the SPBRGH/SPBRGL register pair, the ABDEN bit is automatically cleared and the RCIF interrupt flag is set. The value in the RCREG needs to be read to clear the RCIF interrupt. RCREG content should be discarded. When calibrating for modes that do not use the SPBRGH register, the user can verify that the SPBRGL register did not overflow by checking for 00h in the SPBRGH register.

The BRG auto-baud clock is determined by the BRG16 and BRGH bits, as shown in Table 21-6. During ABD, both the SPBRGH and SPBRGL registers are used as a 16-bit counter, independent of the BRG16 bit setting. While calibrating the baud rate period, the SPBRGH

and SPBRGL registers are clocked at 1/8th the BRG base clock rate. The resulting byte measurement is the average bit time when clocked at full speed.

**Note 1:** If the WUE bit is set with the ABDEN bit, Auto-Baud Detection will occur on the byte following the Break character (see Section 21.4.3 “Auto-Wake-up on Break”).

**2:** It is up to the user to determine that the incoming character baud rate is within the range of the selected BRG clock source. Some combinations of oscillator frequency and EUSART baud rates are not possible.

**3:** During the auto-baud process, the auto-baud counter starts counting at 1. Upon completion of the auto-baud sequence, to achieve maximum accuracy, subtract 1 from the SPBRGH:SPBRGL register pair.

**TABLE 21-6: BRG COUNTER CLOCK RATES**

BRG16	BRGH	BRG Base Clock	BRG ABD Clock
0	0	Fosc/64	Fosc/512
0	1	Fosc/16	Fosc/128
1	0	Fosc/16	Fosc/128
1	1	Fosc/4	Fosc/32

**Note:** During the ABD sequence, the SPBRGL and SPBRGH registers are both used as a 16-bit counter, independent of the BRG16 setting.

**FIGURE 21-6: AUTOMATIC BAUD RATE CALIBRATION**

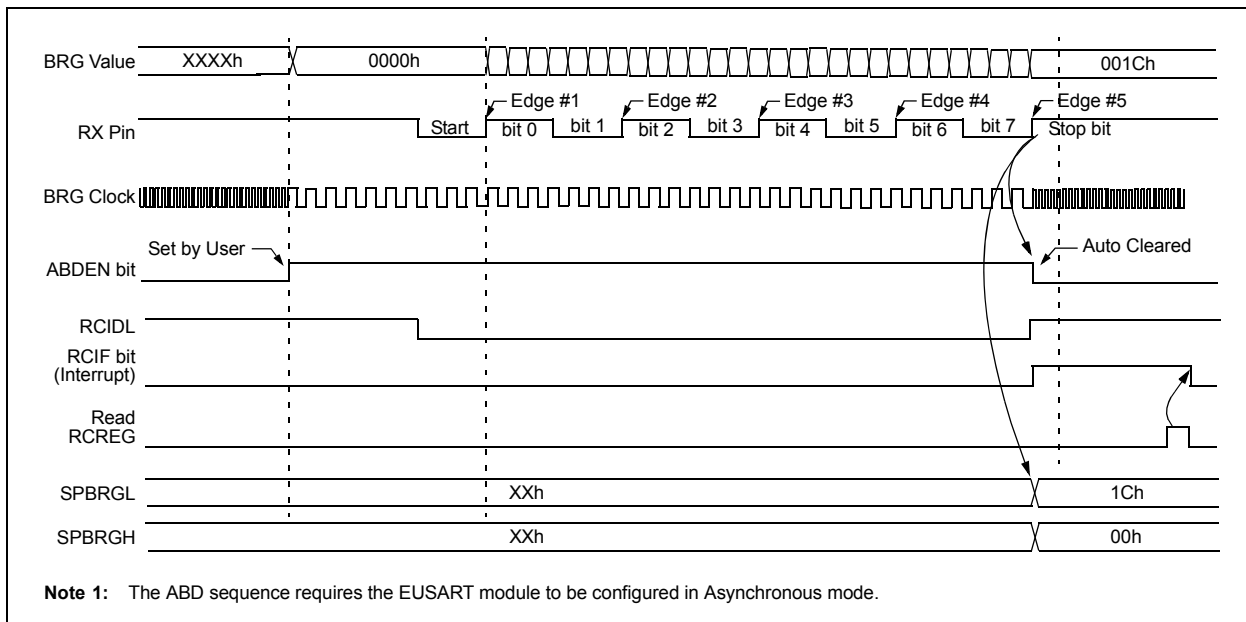



## 21.4.2 AUTO-BAUD OVERFLOW

During the course of Automatic Baud Detection, the ABDOVF bit of the BAUDCON register will be set if the baud rate counter overflows before the fifth rising edge is detected on the RX pin. The ABDOVF bit indicates that the counter has exceeded the maximum count that can fit in the 16 bits of the SPBRGH:SPBRGL register pair. The overflow condition will set the RCIF flag. The counter continues to count until the fifth rising edge is detected on the RX pin. The RCIDL bit will remain false ('0') until the fifth rising edge, at which time, the RDICL bit will set. If the RCREG is read after the overflow occurs, but before the fifth rising edge, the fifth rising edge will set the RCIF again.

Terminating the auto-baud process early to clear an overflow condition will prevent proper detection of the Sync character fifth rising edge. If any falling edges of the Sync character have not yet occurred when the ABDEN bit is cleared, then those will be falsely detected as Start bits. The following steps are recommended to clear the overflow condition:

1. Read RCREG to clear RCIF.
2. If RCIDL is zero, then wait for RCIF and repeat Step 1.
3. Clear the ABDOVF bit.

## 21.4.3 AUTO-WAKE-UP ON BREAK

During Sleep mode, all clocks to the EUSART are suspended. Because of this, the Baud Rate Generator is inactive and a proper character reception cannot be performed. The auto-wake-up feature allows the controller to wake-up due to activity on the RX/DT line. This feature is available only in Asynchronous mode.

The auto-wake-up feature is enabled by setting the WUE bit of the BAUDCON register. Once set, the normal receive sequence on RX/DT is disabled, and the EUSART remains in an Idle state, monitoring for a wake-up event independent of the CPU mode. A wake-up event consists of a high-to-low transition on the RX/DT line. (This coincides with the start of a Sync Break or a wake-up signal character for the LIN protocol.)

The EUSART module generates an RCIF interrupt coincident with the wake-up event. The interrupt is generated synchronously to the Q clocks in normal CPU operating modes (Figure 21-7), and asynchronously if the device is in Sleep mode (Figure 21-8). The interrupt condition is cleared by reading the RCREG register.

The WUE bit is automatically cleared by the low-to-high transition on the RX line at the end of the Break. This signals to the user that the Break event is over. At this point, the EUSART module is in Idle mode waiting to receive the next character.

### 21.4.3.1 Special Considerations

#### Break Character

To avoid character errors or character fragments during a wake-up event, the wake-up character must be all zeros.

When the wake-up is enabled, the function works independent of the low time on the data stream. If the WUE bit is set and a valid non-zero character is received, the low time from the Start bit to the first rising edge will be interpreted as the wake-up event. The remaining bits in the character will be received as a fragmented character and subsequent characters can result in framing or overrun errors.

Therefore, the initial character in the transmission must be all '0's. This must be ten or more bit times; 13-bit times are recommended for LIN bus or any number of bit times for standard RS-232 devices.

#### Oscillator Start-up Time

Oscillator start-up time must be considered, especially in applications using oscillators with longer start-up intervals (i.e., LP, XT or HS/PLL mode). The Sync Break (or wake-up signal) character must be of sufficient length, and be followed by a sufficient interval, to allow enough time for the selected oscillator to start and provide proper initialization of the EUSART.

#### WUE Bit

The wake-up event causes a receive interrupt by setting the RCIF bit. The WUE bit is cleared in hardware by a rising edge on RX/DT. The interrupt condition is then cleared in software by reading the RCREG register and discarding its contents.

To ensure that no actual data is lost, check the RCIDL bit to verify that a receive operation is not in process before setting the WUE bit. If a receive operation is not occurring, the WUE bit may then be set just prior to entering the Sleep mode.

# PIC12(L)F1571/2

**FIGURE 21-7: AUTO-WAKE-UP BIT (WUE) TIMING DURING NORMAL OPERATION**

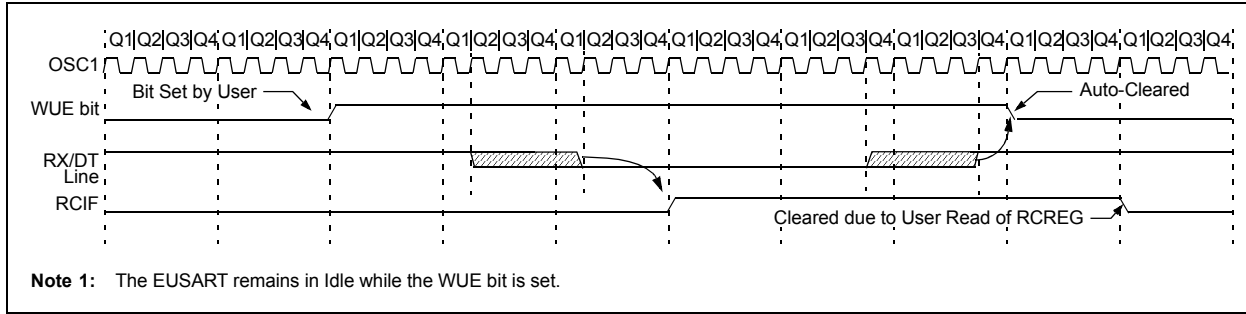

**FIGURE 21-8: AUTO-WAKE-UP BIT (WUE) TIMINGS DURING SLEEP**

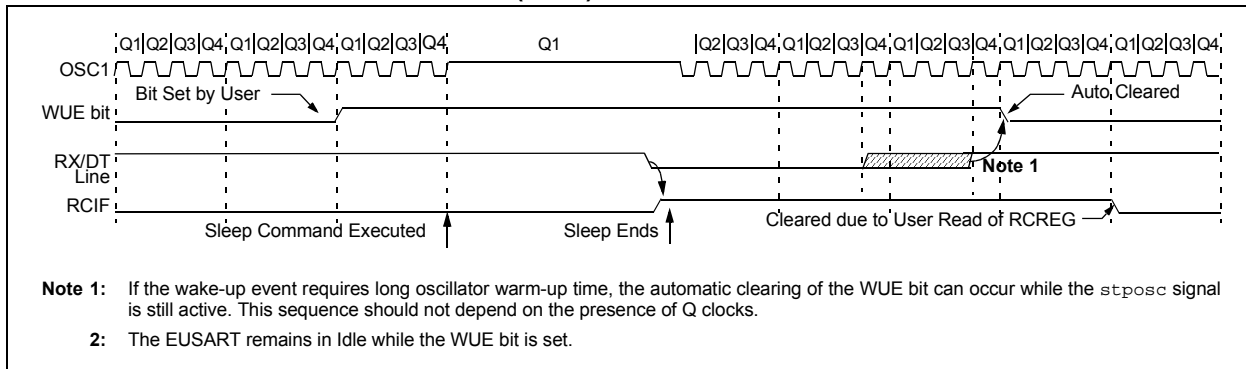

## 21.4.4 BREAK CHARACTER SEQUENCE

The EUSART module has the capability of sending the special Break character sequences that are required by the LIN bus standard. A Break character consists of a Start bit, followed by twelve '0' bits and a Stop bit.

To send a Break character, set the SENDB and TXEN bits of the TXSTA register. The Break character transmission is then initiated by a write to the TXREG. The value of data written to TXREG will be ignored and all '0's will be transmitted.

The SENDB bit is automatically reset by hardware after the corresponding Stop bit is sent. This allows the user to preload the transmit FIFO with the next transmit byte following the Break character (typically, the Sync character in the LIN specification).

The TRMT bit of the TXSTA register indicates when the transmit operation is active or idle, just as it does during normal transmission. See [Figure 21-9](#) for the timing of the Break character sequence.

### 21.4.4.1 Break and Sync Transmit Sequence

The following sequence will start a message frame header made up of a Break, followed by an auto-baud Sync byte. This sequence is typical of a LIN bus master.

1. Configure the EUSART for the desired mode.
2. Set the TXEN and SENDB bits to enable the Break sequence.
3. Load the TXREG with a dummy character to initiate transmission (the value is ignored).
4. Write '55h' to TXREG to load the Sync character into the transmit FIFO buffer.
5. After the Break has been sent, the SENDB bit is reset by hardware and the Sync character is then transmitted.

When the TXREG becomes empty, as indicated by the TXIF, the next data byte can be written to TXREG.

## 21.4.5 RECEIVING A BREAK CHARACTER

The Enhanced USART module can receive a Break character in two ways.

The first method to detect a Break character uses the FERR bit of the RCSTA register and the received data as indicated by RCREG. The Baud Rate Generator is assumed to have been initialized to the expected baud rate.

A Break character has been received when:

- RCIF bit is set
- FERR bit is set
- RCREG = 00h

The second method uses the auto-wake-up feature described in [Section 21.4.3 "Auto-Wake-up on Break"](#). By enabling this feature, the EUSART will sample the next two transitions on RX/DT, cause an RCIF interrupt and receive the next data byte followed by another interrupt.

Note that following a Break character, the user will typically want to enable the Auto-Baud Detect feature. For both methods, the user can set the ABDEN bit of the BAUDCON register before placing the EUSART in Sleep mode.

**FIGURE 21-9: SEND BREAK CHARACTER SEQUENCE**

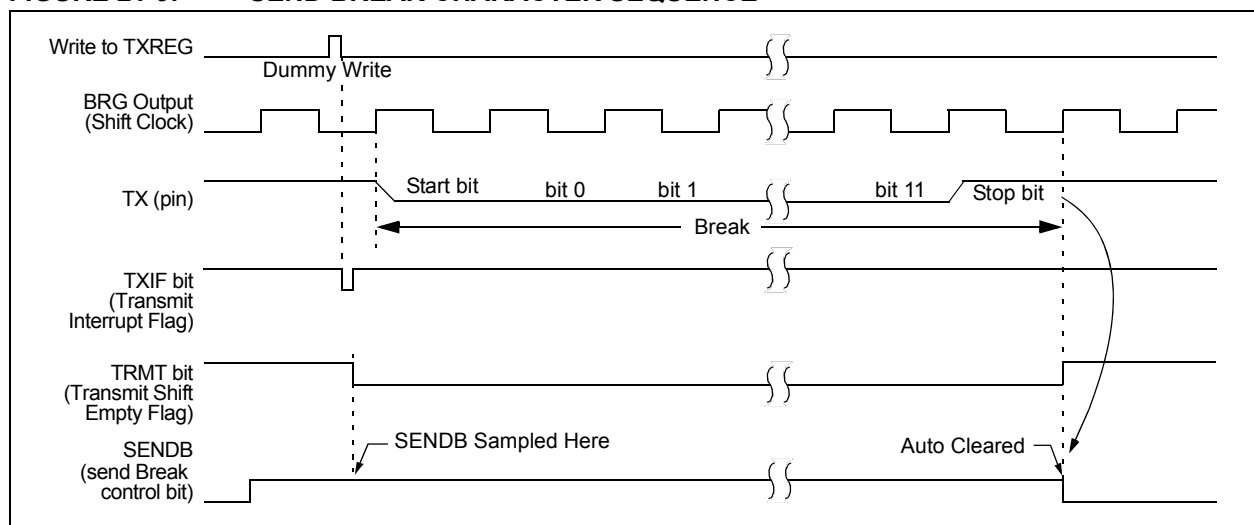

## 21.5 EUSART Synchronous Mode

Synchronous serial communications are typically used in systems with a single master and one or more slaves. The master device contains the necessary circuitry for baud rate generation and supplies the clock for all devices in the system. Slave devices can take advantage of the master clock by eliminating the internal clock generation circuitry.

There are two signal lines in Synchronous mode: a bidirectional data line and a clock line. Slaves use the external clock supplied by the master to shift the serial data into and out of their respective Receive and Transmit Shift registers. Since the data line is bidirectional, synchronous operation is half-duplex only. Half-duplex refers to the fact that master and slave devices can receive and transmit data but not both simultaneously. The EUSART can operate as either a master or slave device.

Start and Stop bits are not used in synchronous transmissions.

### 21.5.1 SYNCHRONOUS MASTER MODE

The following bits are used to configure the EUSART for synchronous master operation:

- SYNC = 1
- CSRC = 1
- SREN = 0 (for transmit); SREN = 1 (for receive)
- CREN = 0 (for transmit); CREN = 1 (for receive)
- SPEN = 1

Setting the SYNC bit of the TXSTA register configures the device for synchronous operation. Setting the CSRC bit of the TXSTA register configures the device as a master. Clearing the SREN and CREN bits of the RCSTA register ensures that the device is in the Transmit mode, otherwise the device will be configured to receive. Setting the SPEN bit of the RCSTA register enables the EUSART.

#### 21.5.1.1 Master Clock

Synchronous data transfers use a separate clock line, which is synchronous with the data. A device configured as a master transmits the clock on the TX/CK line. The TX/CK pin output driver is automatically enabled when the EUSART is configured for synchronous transmit or receive operation. Serial data bits change on the leading edge to ensure they are valid at the trailing edge of each clock. One clock cycle is generated for each data bit. Only as many clock cycles are generated as there are data bits.

#### 21.5.1.2 Clock Polarity

A clock polarity option is provided for Microwire compatibility. Clock polarity is selected with the SCKP bit of the BAUDCON register. Setting the SCKP bit sets the clock Idle state as high. When the SCKP bit is set, the data changes on the falling edge of each clock. Clearing the SCKP bit sets the Idle state as low. When the SCKP bit is cleared, the data changes on the rising edge of each clock.

#### 21.5.1.3 Synchronous Master Transmission

Data is transferred out of the device on the RX/DT pin. The RX/DT and TX/CK pin output drivers are automatically enabled when the EUSART is configured for synchronous master transmit operation.

A transmission is initiated by writing a character to the TXREG register. If the TSR still contains all or part of a previous character the new character data is held in the TXREG until the last bit of the previous character has been transmitted. If this is the first character, or the previous character has been completely flushed from the TSR, the data in the TXREG is immediately transferred to the TSR. The transmission of the character commences immediately following the transfer of the data to the TSR from the TXREG.

Each data bit changes on the leading edge of the master clock and remains valid until the subsequent leading clock edge.

**Note:** The TSR register is not mapped in data memory, so it is not available to the user.

#### 21.5.1.4 Synchronous Master Transmission Setup

1. Initialize the SPBRGH, SPBRGL register pair and the BRGH and BRG16 bits to achieve the desired baud rate (see [Section 21.4 “EUSART Baud Rate Generator \(BRG\)”](#)).
2. Enable the synchronous master serial port by setting bits, SYNC, SPEN and CSRC.
3. Disable Receive mode by clearing bits, SREN and CREN.
4. Enable Transmit mode by setting the TXEN bit.
5. If 9-bit transmission is desired, set the TX9 bit.
6. If interrupts are desired, set the TXIE bit of the PIE1 register, and the GIE and PEIE bits of the INTCON register.
7. If 9-bit transmission is selected, the ninth bit should be loaded in the TX9D bit.
8. Start transmission by loading data to the TXREG register.

**FIGURE 21-10: SYNCHRONOUS TRANSMISSION**

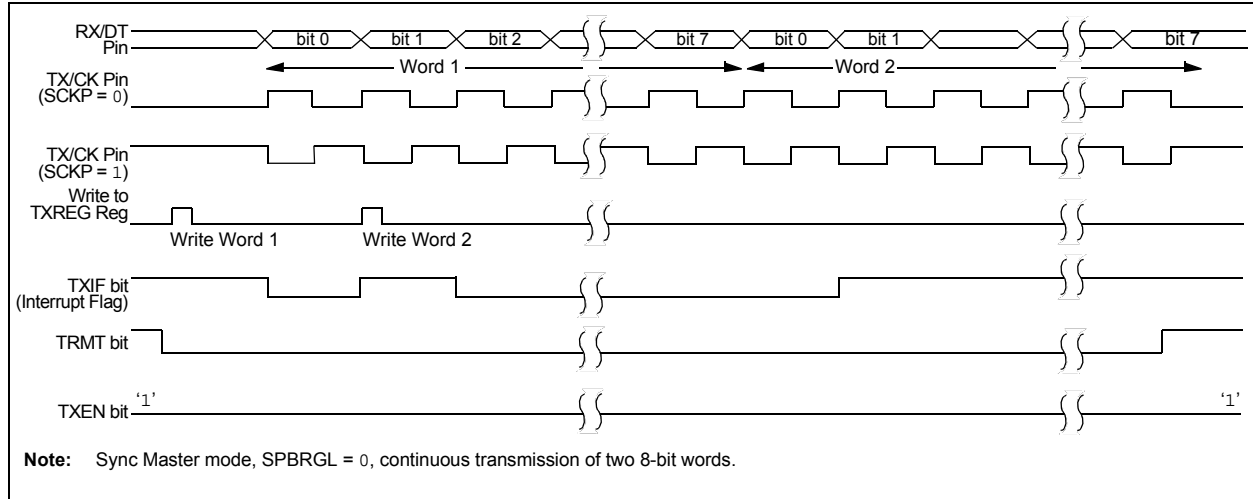

**FIGURE 21-11: SYNCHRONOUS TRANSMISSION (THROUGH TXEN)**

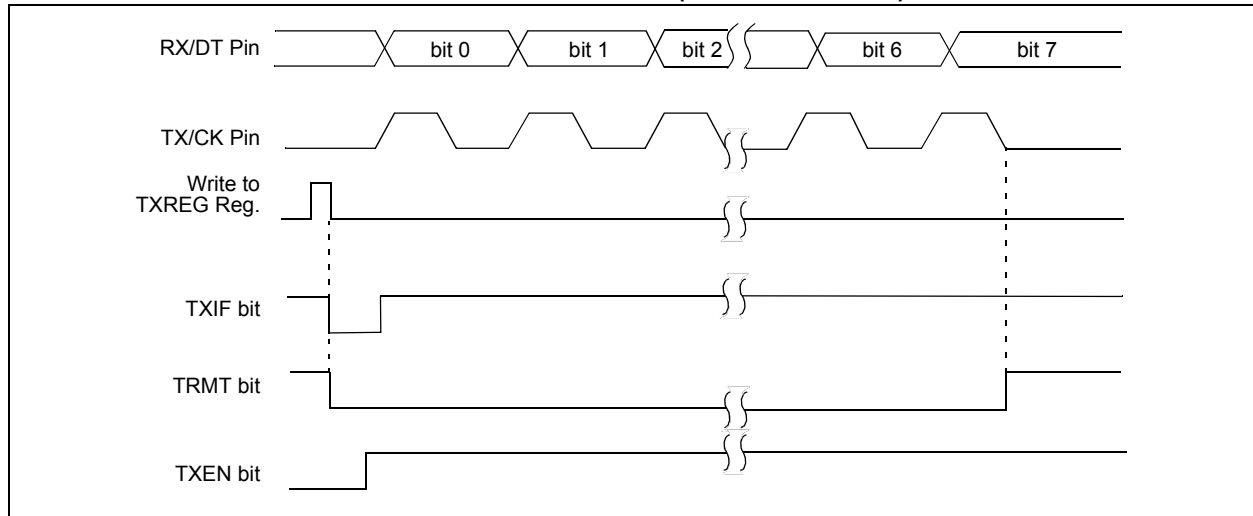

**TABLE 21-7: SUMMARY OF REGISTERS ASSOCIATED WITH SYNCHRONOUS MASTER TRANSMISSION**

Name	Bit 7	Bit 6	Bit 5	Bit 4	Bit 3	Bit 2	Bit 1	Bit 0	Register on Page
BAUDCON	ABDOVF	RCIDL	—	SCKP	BRG16	—	WUE	ABDEN	186
INTCON	GIE	PEIE	TMR0IE	INTE	IOCIE	TMR0IF	INTF	IOCIF	74
PIE1	TMR1GIE	ADIE	RCIE <sup>(1)</sup>	TXIE <sup>(1)</sup>	—	—	TMR2IE	TMR1IE	75
PIR1	TMR1GIF	ADIF	RCIF <sup>(1)</sup>	TXIF <sup>(1)</sup>	—	—	TMR2IF	TMR1IF	78
RCSTA	SPEN	RX9	SREN	CREN	ADDEN	FERR	OERR	RX9D	185
SPBRGL	BRG<7:0>								187*
SPBRGH	BRG<15:8>								187*
TXREG	EUSART Transmit Data Register								177*
TXSTA	CSRC	TX9	TXEN	SYNC	SENDB	BRGH	TRMT	TX9D	184

**Legend:** — = unimplemented location, read as '0'. Shaded cells are not used for synchronous master transmission.

\* Page provides register information.

**Note 1:** PIC12(L)F1572 only.

# PIC12(L)F1571/2

## 21.5.1.5 Synchronous Master Reception

Data is received at the RX/DT pin. The RX/DT pin output driver is automatically disabled when the EUSART is configured for synchronous master receive operation.

In Synchronous mode, reception is enabled by setting either the Single Receive Enable bit (SREN of the RCSTA register) or the Continuous Receive Enable bit (CREN of the RCSTA register).

When SREN is set and CREN is clear, only as many clock cycles are generated as there are data bits in a single character. The SREN bit is automatically cleared at the completion of one character. When CREN is set, clocks are continuously generated until CREN is cleared. If CREN is cleared in the middle of a character, the CK clock stops immediately and the partial character is discarded. If SREN and CREN are both set, then SREN is cleared at the completion of the first character and CREN takes precedence.

To initiate reception, set either SREN or CREN. Data is sampled at the RX/DT pin on the trailing edge of the TX/CK clock pin and is shifted into the Receive Shift Register (RSR). When a complete character is received into the RSR, the RCIF bit is set and the character is automatically transferred to the two-character receive FIFO. The Least Significant eight bits of the top character in the receive FIFO are available in RCREG. The RCIF bit remains set as long as there are unread characters in the receive FIFO.

**Note:** If the RX/DT function is on an analog pin, the corresponding ANSELx bit must be cleared for the receiver to function.

## 21.5.1.6 Slave Clock

Synchronous data transfers use a separate clock line, which is synchronous with the data. A device configured as a slave receives the clock on the TX/CK line. The TX/CK pin output driver is automatically disabled when the device is configured for synchronous slave transmit or receive operation. Serial data bits change on the leading edge to ensure they are valid at the trailing edge of each clock. One data bit is transferred for each clock cycle. Only as many clock cycles should be received as there are data bits.

**Note:** If the device is configured as a slave and the TX/CK function is on an analog pin, the corresponding ANSELx bit must be cleared.

## 21.5.1.7 Receive Overrun Error

The receive FIFO buffer can hold two characters. An overrun error will be generated if a third character, in its entirety, is received before RCREG is read to access the FIFO. When this happens, the OERR bit of the RCSTA register is set. Previous data in the FIFO will not be overwritten. The two characters in the FIFO buffer can be read, however, no additional characters will be received until the error is cleared. The OERR bit can only be cleared by clearing the overrun condition. If the overrun error occurred when the SREN bit is set and CREN is clear, then the error is cleared by reading RCREG. If the overrun occurred when the CREN bit is set, then the error condition is cleared by either clearing the CREN bit of the RCSTA register or by clearing the SPEN bit which resets the EUSART.

## 21.5.1.8 Receiving 9-Bit Characters

The EUSART supports 9-bit character reception. When the RX9 bit of the RCSTA register is set the EUSART will shift 9 bits into the RSR for each character received. The RX9D bit of the RCSTA register is the ninth, and Most Significant, data bit of the top unread character in the receive FIFO. When reading 9-bit data from the receive FIFO buffer, the RX9D data bit must be read before reading the eight Least Significant bits from the RCREG.

## 21.5.1.9 Synchronous Master Reception Setup

1. Initialize the SPBRGH/SPBRGL register pair for the appropriate baud rate. Set or clear the BRGH and BRG16 bits, as required, to achieve the desired baud rate.
2. Clear the ANSELx bit for the RX pin (if applicable).
3. Enable the synchronous master serial port by setting bits, SYNC, SPEN and CSRC.
4. Ensure bits, CREN and SREN, are clear.
5. If interrupts are desired, set the RCIE bit of the PIE1 register, and the GIE and PEIE bits of the INTCON register.
6. If 9-bit reception is desired, set bit, RX9.
7. Start reception by setting the SREN bit or for continuous reception, set the CREN bit.
8. Interrupt flag bit, RCIF, will be set when reception of a character is complete. An interrupt will be generated if the enable bit, RCIE, was set.
9. Read the RCSTA register to get the ninth bit (if enabled) and determine if any error occurred during reception.
10. Read the 8-bit received data by reading the RCREG register.
11. If an overrun error occurs, clear the error by either clearing the CREN bit of the RCSTA register or by clearing the SPEN bit which resets the EUSART.

**FIGURE 21-12: SYNCHRONOUS RECEPTION (MASTER MODE, SREN)**

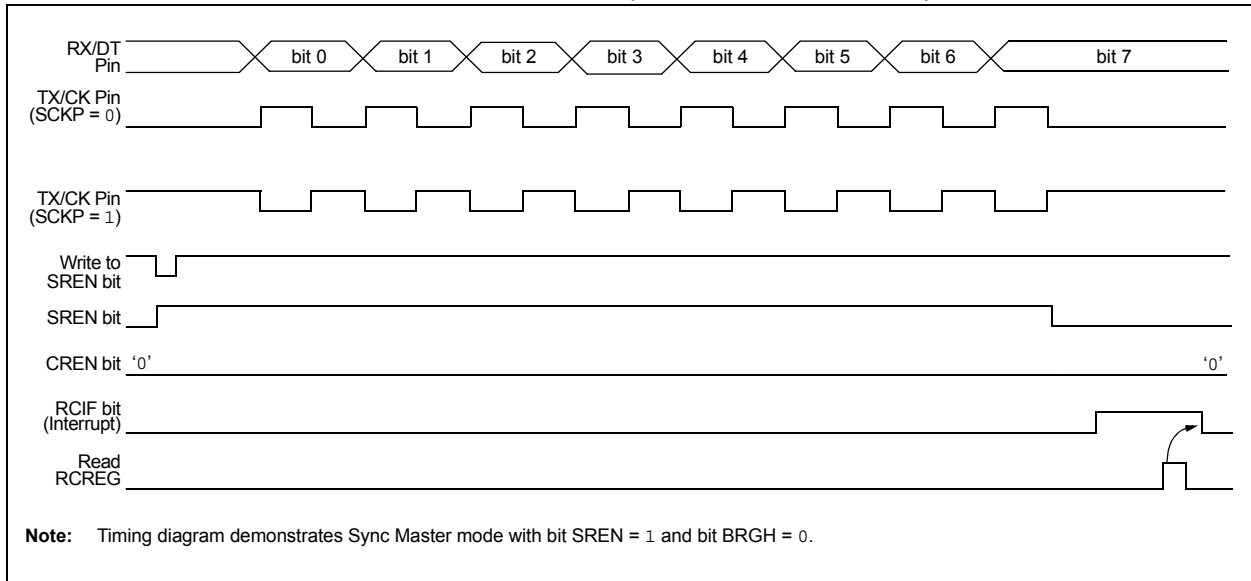

**TABLE 21-8: SUMMARY OF REGISTERS ASSOCIATED WITH SYNCHRONOUS MASTER RECEPTION**

Name	Bit 7	Bit 6	Bit 5	Bit 4	Bit 3	Bit 2	Bit 1	Bit 0	Register on Page
BAUDCON	ABDOVF	RCIDL	—	SCKP	BRG16	—	WUE	ABDEN	186
INTCON	GIE	PEIE	TMR0IE	INTE	IOCF	TMR0IF	INTF	IOCF	74
PIE1	TMR1GIE	ADIE	RCIE <sup>(1)</sup>	TXIE <sup>(1)</sup>	—	—	TMR2IE	TMR1IE	75
PIR1	TMR1GIF	ADIF	RCIF <sup>(1)</sup>	TXIF <sup>(1)</sup>	—	—	TMR2IF	TMR1IF	78
RCREG	EUSART Receive Data Register								180*
RCSTA	SPEN	RX9	SREN	CREN	ADDEN	FERR	OERR	RX9D	185
SPBRGL	BRG<7:0>								187*
SPBRGH	BRG<15:8>								187*
TXSTA	CSRC	TX9	TXEN	SYNC	SENDB	BRGH	TRMT	TX9D	184

**Legend:** — = unimplemented location, read as '0'. Shaded cells are not used for synchronous master reception.

\* Page provides register information.

**Note 1:** PIC12(L)F1572 only.

# PIC12(L)F1571/2

## 21.5.2 SYNCHRONOUS SLAVE MODE

The following bits are used to configure the EUSART for synchronous slave operation:

- SYNC = 1
- CSRC = 0
- SREN = 0 (for transmit); SREN = 1 (for receive)
- CREN = 0 (for transmit); CREN = 1 (for receive)
- SPEN = 1

Setting the SYNC bit of the TXSTA register configures the device for synchronous operation. Clearing the CSRC bit of the TXSTA register configures the device as a slave. Clearing the SREN and CREN bits of the RCSTA register ensures that the device is in Transmit mode; otherwise, the device will be configured to receive. Setting the SPEN bit of the RCSTA register enables the EUSART.

### 21.5.2.1 EUSART Synchronous Slave Transmit

The operation of the Synchronous Master and Slave modes is identical (see [Section 21.5.1.3 “Synchronous Master Transmission”](#)), except in the case of Sleep mode.

If two words are written to the TXREG and then the SLEEP instruction is executed, the following will occur:

1. The first character will immediately transfer to the TSR register and transmit.
2. The second word will remain in the TXREG register.
3. The TXIF bit will not be set.
4. After the first character has been shifted out of TSR, the TXREG register will transfer the second character to the TSR and the TXIF bit will now be set.
5. If the PEIE and TXIE bits are set, the interrupt will wake the device from Sleep and execute the next instruction. If the GIE bit is also set, the program will call the Interrupt Service Routine.

### 21.5.2.2 Synchronous Slave Transmission Setup

1. Set the SYNC and SPEN bits, and clear the CSRC bit.
2. Clear the ANSELx bit for the CK pin (if applicable).
3. Clear the CREN and SREN bits.
4. If interrupts are desired, set the TXIE bit of the PIE1 register and the GIE and PEIE bits of the INTCON register.
5. If 9-bit transmission is desired, set the TX9 bit.
6. Enable transmission by setting the TXEN bit.
7. If 9-bit transmission is selected, insert the Most Significant bit into the TX9D bit.
8. Start transmission by writing the Least Significant eight bits to the TXREG register.

**TABLE 21-9: SUMMARY OF REGISTERS ASSOCIATED WITH SYNCHRONOUS SLAVE TRANSMISSION**

Name	Bit 7	Bit 6	Bit 5	Bit 4	Bit 3	Bit 2	Bit 1	Bit 0	Register on Page
BAUDCON	ABDOVF	RCIDL	—	SCKP	BRG16	—	WUE	ABDEN	186
INTCON	GIE	PEIE	TMR0IE	INTE	IOCIE	TMR0IF	INTF	IOCIF	74
PIE1	TMR1GIE	ADIE	RCIE <sup>(1)</sup>	TXIE <sup>(1)</sup>	—	—	TMR2IE	TMR1IE	75
PIR1	TMR1GIF	ADIF	RCIF <sup>(1)</sup>	TXIF <sup>(1)</sup>	—	—	TMR2IF	TMR1IF	78
RCSTA	SPEN	RX9	SREN	CREN	ADDEN	FERR	OERR	RX9D	185
TXREG	EUSART Transmit Data Register								177*
TXSTA	CSRC	TX9	TXEN	SYNC	SENDB	BRGH	TRMT	TX9D	184

**Legend:** — = unimplemented location, read as ‘0’. Shaded cells are not used for synchronous slave transmission.

\* Page provides register information.

**Note 1:** PIC12(L)F1572 only.



## 21.5.2.3 EUSART Synchronous Slave Reception

The operation of the Synchronous Master and Slave modes is identical ([Section 21.5.1.5 “Synchronous Master Reception”](#)), with the following exceptions:

- Sleep
- CREN bit is always set, therefore, the receiver is never Idle
- SREN bit, which is a “don’t care” in Slave mode

A character may be received while in Sleep mode by setting the CREN bit prior to entering Sleep. Once the word is received, the RSR register will transfer the data to the RCREG register. If the RCIE enable bit is set, the interrupt generated will wake the device from Sleep and execute the next instruction. If the GIE bit is also set, the program will branch to the interrupt vector.

## 21.5.2.4 Synchronous Slave Reception Setup

1. Set the SYNC and SPEN bits, and clear the CSRC bit.
2. Clear the ANSELx bit for both the CK and DT pins (if applicable).
3. If interrupts are desired, set the RCIE bit of the PIE1 register, and the GIE and PEIE bits of the INTCON register.
4. If 9-bit reception is desired, set the RX9 bit.
5. Set the CREN bit to enable reception.
6. The RCIF bit will be set when reception is complete. An interrupt will be generated if the RCIE bit was set.
7. If 9-bit mode is enabled, retrieve the Most Significant bit from the RX9D bit of the RCSTA register.
8. Retrieve the eight Least Significant bits from the receive FIFO by reading the RCREG register.
9. If an overrun error occurs, clear the error by either clearing the CREN bit of the RCSTA register or by clearing the SPEN bit which resets the EUSART.

**TABLE 21-10: SUMMARY OF REGISTERS ASSOCIATED WITH SYNCHRONOUS SLAVE RECEPTION**

Name	Bit 7	Bit 6	Bit 5	Bit 4	Bit 3	Bit 2	Bit 1	Bit 0	Register on Page
BAUDCON	ABDOVF	RCIDL	—	SCKP	BRG16	—	WUE	ABDEN	186
INTCON	GIE	PEIE	TMR0IE	INTE	IOCIE	TMR0IF	INTF	IOCIF	74
PIE1	TMR1GIE	ADIE	RCIE <sup>(1)</sup>	TXIE <sup>(1)</sup>	—	—	TMR2IE	TMR1IE	75
PIR1	TMR1GIF	ADIF	RCIF <sup>(1)</sup>	TXIF <sup>(1)</sup>	—	—	TMR2IF	TMR1IF	78
RCREG	EUSART Receive Data Register								180*
RCSTA	SPEN	RX9	SREN	CREN	ADDEN	FERR	OERR	RX9D	185
TXSTA	CSRC	TX9	TXEN	SYNC	SENDB	BRGH	TRMT	TX9D	184

**Legend:** — = unimplemented location, read as ‘0’. Shaded cells are not used for synchronous slave reception.

\* Page provides register information.

**Note 1:** PIC12(L)F1572 only.

# PIC12(L)F1571/2

---

NOTES:

## 22.0 16-BIT PULSE-WIDTH MODULATION (PWM) MODULE

The Pulse-Width Modulation (PWM) module generates a pulse-width modulated signal determined by the phase, duty cycle, period and offset event counts that are contained in the following registers:

- PWMxPH register
- PWMxDC register
- PWMxPR register
- PWMxOF register

Figure 22-1 shows a simplified block diagram of the PWM operation.

Each PWM module has four modes of operation:

- Standard
- Set On Match
- Toggle On Match
- Center-Aligned

For a more detailed description of each PWM mode, refer to Section 22.2 “PWM Modes”.

Each PWM module has four Offset modes:

- Independent Run
- Slave Run with Synchronous Start
- One-Shot Slave with Synchronous Start
- Continuous Run Slave with Synchronous Start and Timer Reset

Using the Offset modes, each PWM module can offset its waveform relative to any other PWM module in the same device. For a more detailed description of the Offset modes, refer to Section 22.3 “Offset Modes”.

Every PWM module has a configurable reload operation to ensure all event count buffers change at the end of a period, thereby avoiding signal glitches. Figure 22-2 shows a simplified block diagram of the reload operation. For a more detailed description of the reload operation, refer to Section 22.4 “Reload Operation”.

**FIGURE 22-1: 16-BIT PWM BLOCK DIAGRAM**

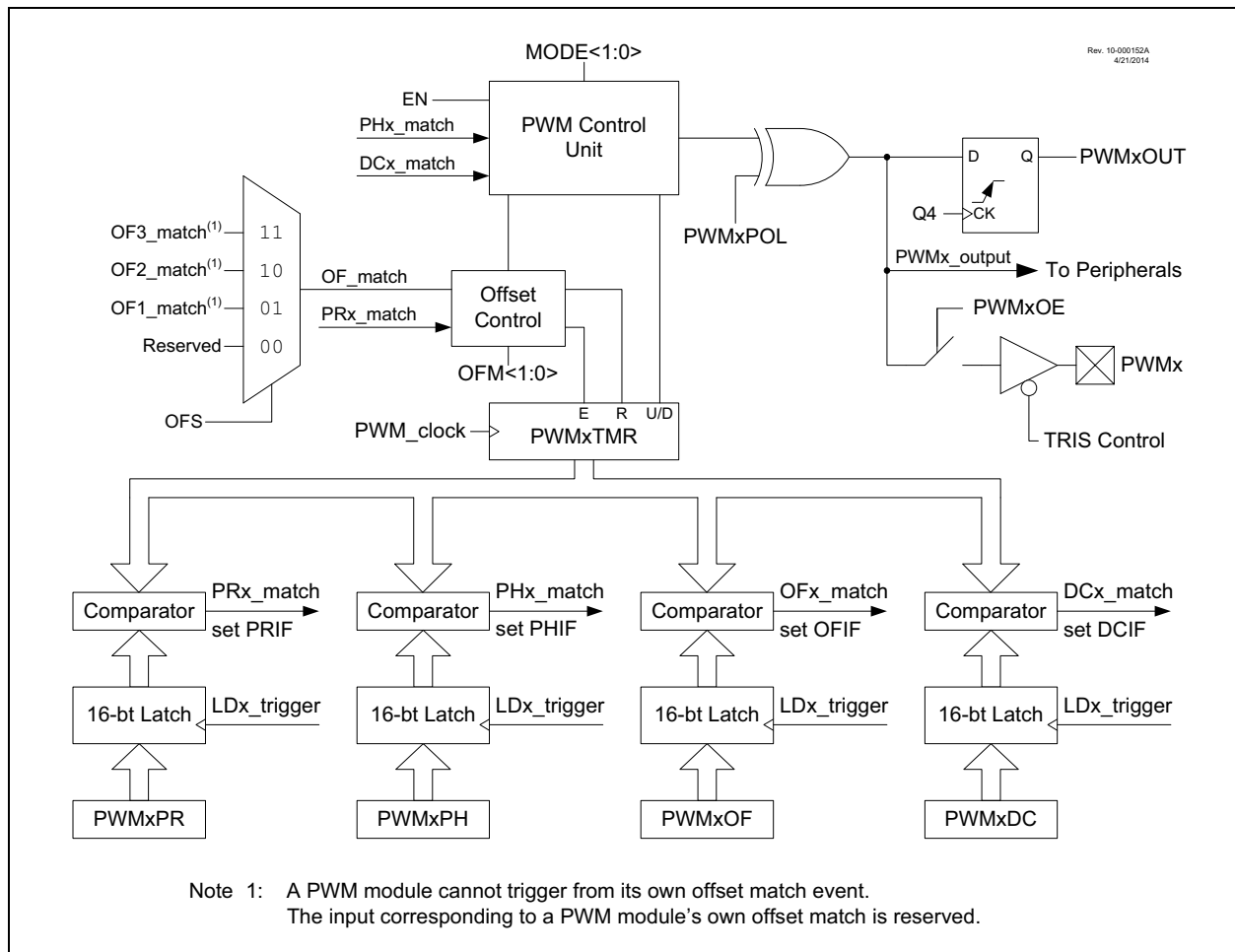

# PIC12(L)F1571/2

**FIGURE 22-2: LOAD TRIGGER BLOCK DIAGRAM**

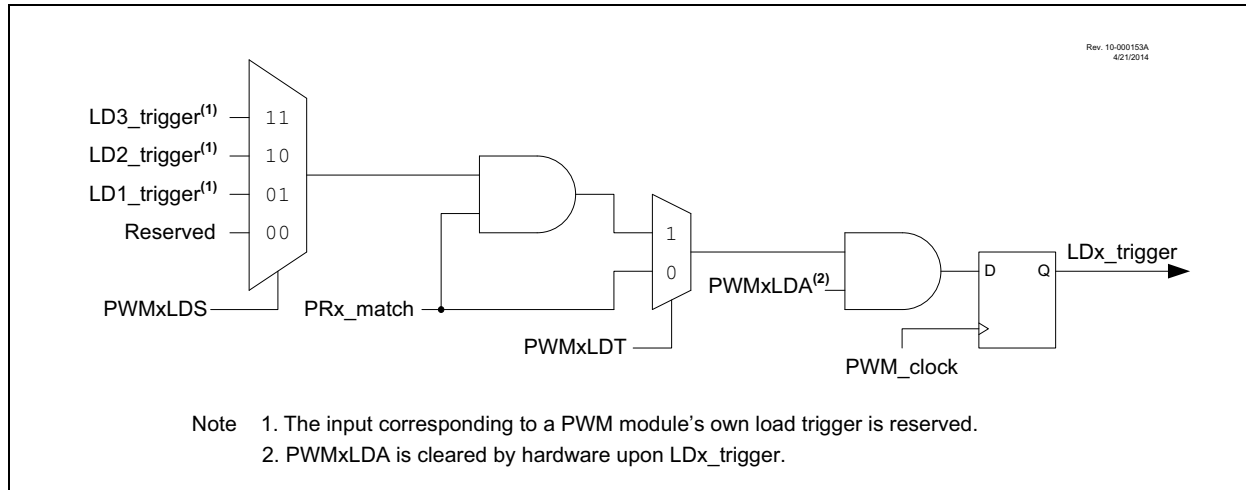

## 22.1 Fundamental Operation

The PWM module produces a 16-bit resolution pulse-width modulated output.

Each PWM module has an independent timer driven by a selection of clock sources determined by the PWMxCLKCON register (Register 22-4). The timer value is compared to event count registers to generate the various events of a the PWM waveform, such as the period and duty cycle. For a block diagram describing the clock sources, refer to Figure 22-3.

Each PWM module can be enabled individually using the EN bit of the PWMxCON register, or several PWM modules can be enabled simultaneously using the mirror bits of the PWMEN register.

The current state of the PWM output can be read using the OUT bit of the PWMxCON register. In some modes, this bit can be set and cleared by software, giving additional software control over the PWM waveform. This bit is synchronized to  $F_{osc}/4$  and therefore, does not change in real time with respect to the PWM\_clock.

**Note:** If  $PWM\_clock > F_{osc}/4$ , the OUT bit may not accurately represent the output state of the PWM.

**FIGURE 22-3: PWM CLOCK SOURCE BLOCK DIAGRAM**

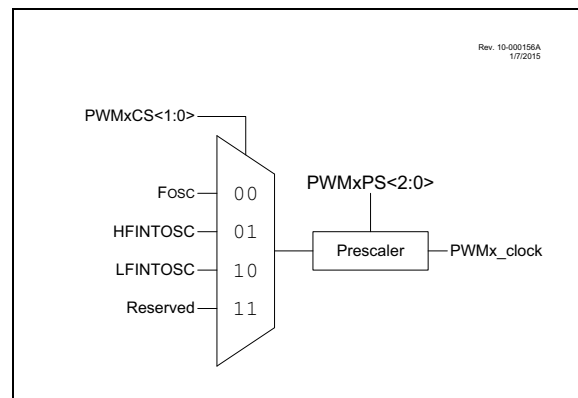

### 22.1.1 PWMx PIN CONFIGURATION

All PWM outputs are multiplexed with the PORT data latch, so the pins must also be configured as outputs by clearing the associated PORT TRISx bits.

The slow rate feature may be configured to optimize the rate to be used in conjunction with the PWM outputs. High-speed output switching is attained by clearing the associated PORT SLRCONx bits.

The PWM outputs can be configured to be open-drain outputs by setting the associated PORT ODCONx bits.

### 22.1.2 PWMx Output Polarity

The output polarity is inverted by setting the POL bit of the PWMxCON register. The polarity control affects the PWM output even when the module is not enabled.

## 22.2 PWM Modes

PWM modes are selected with the MODE<1:0> bits of the PWMxCON register (Register 22-1).

In all PWM modes, an offset match event can also be used to synchronize the PWMxTMR in three Offset modes. See Section 22.3 “Offset Modes” for more information.

### 22.2.1 STANDARD MODE

The Standard mode (MODE<1:0> = 00) selects a single-phase PWM output. The PWM output in this mode is determined by when the period, duty cycle and phase counts match the PWMxTMR value. The start of the duty cycle occurs on the phase match and the end of the duty cycle occurs on the duty cycle match. The period match resets the timer. The offset match can also be used to synchronize the PWMxTMR in the Offset modes. See Section 22.3 “Offset Modes” for more information.

Equation 22-1 is used to calculate the PWM period in Standard mode.

Equation 22-2 is used to calculate the PWM duty cycle ratio in Standard mode.

#### EQUATION 22-1: PWM PERIOD IN STANDARD MODE

$$Period = \frac{(PWMxPR + 1) \cdot Prescale}{PWMxCLK}$$

#### EQUATION 22-2: PWM DUTY CYCLE IN STANDARD MODE

$$Duty\ Cycle = \frac{(PWMxDC - PWMxPH)}{PWMxPR + 1}$$

A detailed timing diagram for Standard mode is shown in Figure 22-4.

### 22.2.2 SET ON MATCH MODE

The Set On Match mode (MODE<1:0> = 01) generates an active output when the phase count matches the PWMxTMR value. The output stays active until the OUT bit of the PWMxCON register is cleared or the PWM module is disabled. The duty cycle count has no effect in this mode. The period count only determines the maximum PWMxTMR value above which no phase matches can occur.

The OUT bit can be used to set or clear the output of the PWM in this mode. Writes to this bit will take place on the next rising edge of the PWM\_clock after the bit is written.

A detailed timing diagram for Set On Match mode is shown in Figure 22-5.

### 22.2.3 TOGGLE ON MATCH MODE

The Toggle On Match mode (MODE<1:0> = 10) generates a 50% duty cycle PWM with a period twice as long as that computed for the Standard PWM mode. Duty cycle count has no effect in this mode. The phase count determines how many PWMxTMR periods, after a period event, the output will toggle.

Writes to the OUT bit of the PWMxCON register will have no effect in this mode.

A detailed timing diagram for Toggle On Match mode is shown in Figure 22-6.

### 22.2.4 CENTER-ALIGNED MODE

The Center-Aligned mode (MODE = 11) generates a PWM waveform that is centered in the period. In this mode, the period is two times the PWMxPR count. The PWMxTMR counts up to the period value, then counts back down to 0. The duty cycle count determines both the start and end of the active PWM output. The start of the duty cycle occurs at the match event when PWMxTMR is incrementing and the duty cycle ends at the match event when PWMxTMR is decrementing. The incrementing match value is the period count minus the duty cycle count. The decrementing match value is the incrementing match value plus 1.

Equation 22-3 is used to calculate the PWM period in Center-Aligned mode.

#### EQUATION 22-3: PWM PERIOD IN CENTER-ALIGNED MODE

$$Period = \frac{(PWMxPR + 1) \cdot Prescale \cdot 2}{PWMxCLK}$$

Equation 22-4 is used to calculate the PWM duty cycle ratio in Center-Aligned mode.

#### EQUATION 22-4: PWM DUTY CYCLE IN CENTER-ALIGNED MODE

$$Duty\ Cycle = \frac{PWMxDC \cdot 2}{(PWMxPR + 1) \cdot 2}$$

Writes to the OUT bit will have no effect in this mode.

A detailed timing diagram for Center-Aligned mode is shown in Figure 22-7.

**FIGURE 22-4: STANDARD PWM MODE TIMING DIAGRAM**

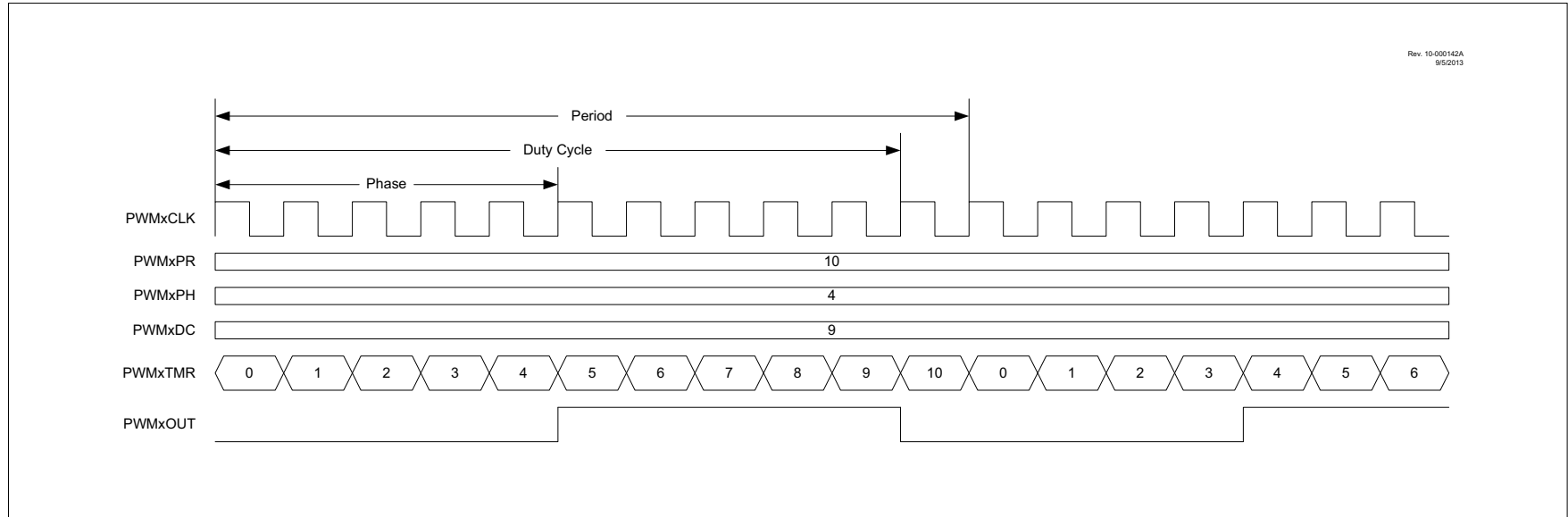

**FIGURE 22-5: SET ON MATCH PWM MODE TIMING DIAGRAM**

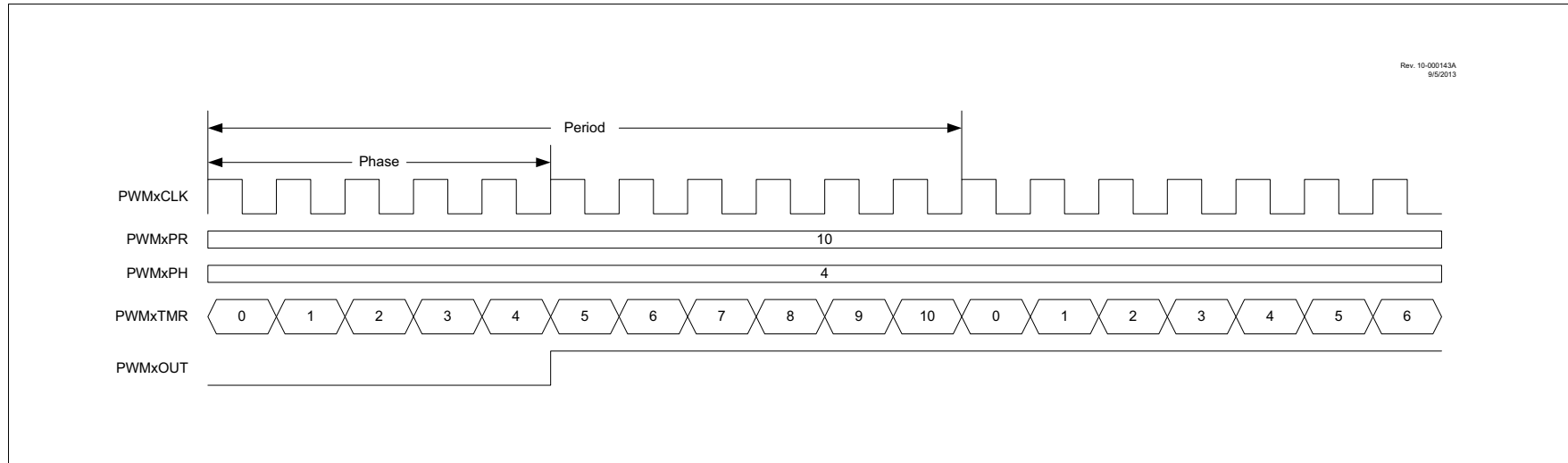

**FIGURE 22-6: TOGGLE ON MATCH PWM MODE TIMING DIAGRAM**

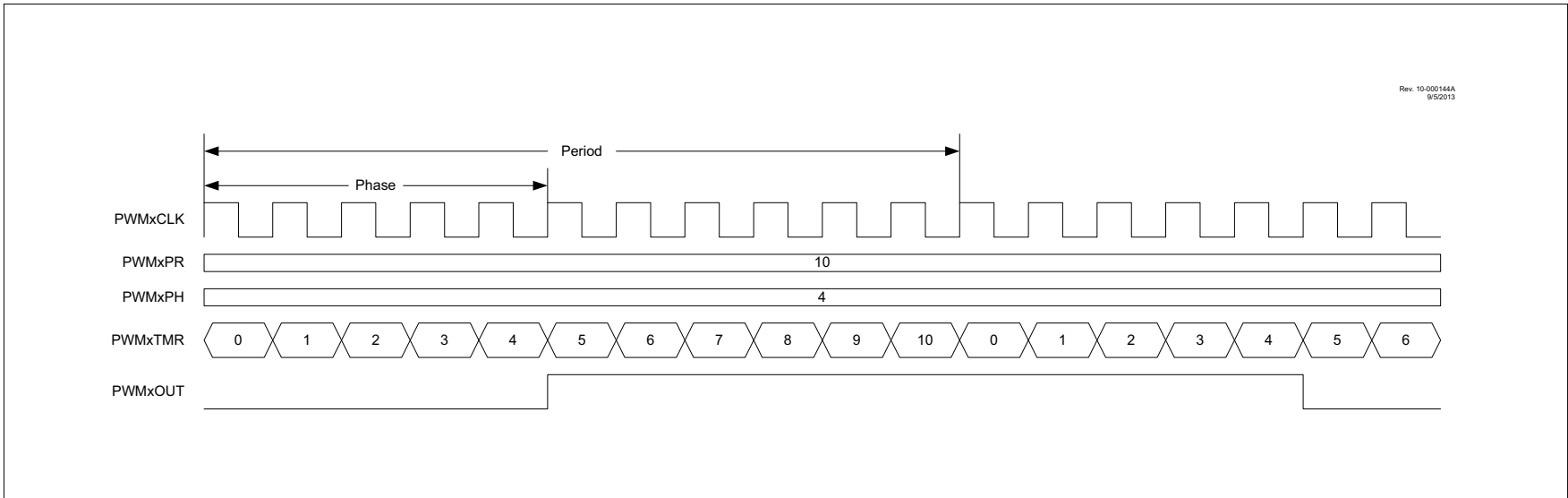

**FIGURE 22-7: CENTER-ALIGNED PWM MODE TIMING DIAGRAM**

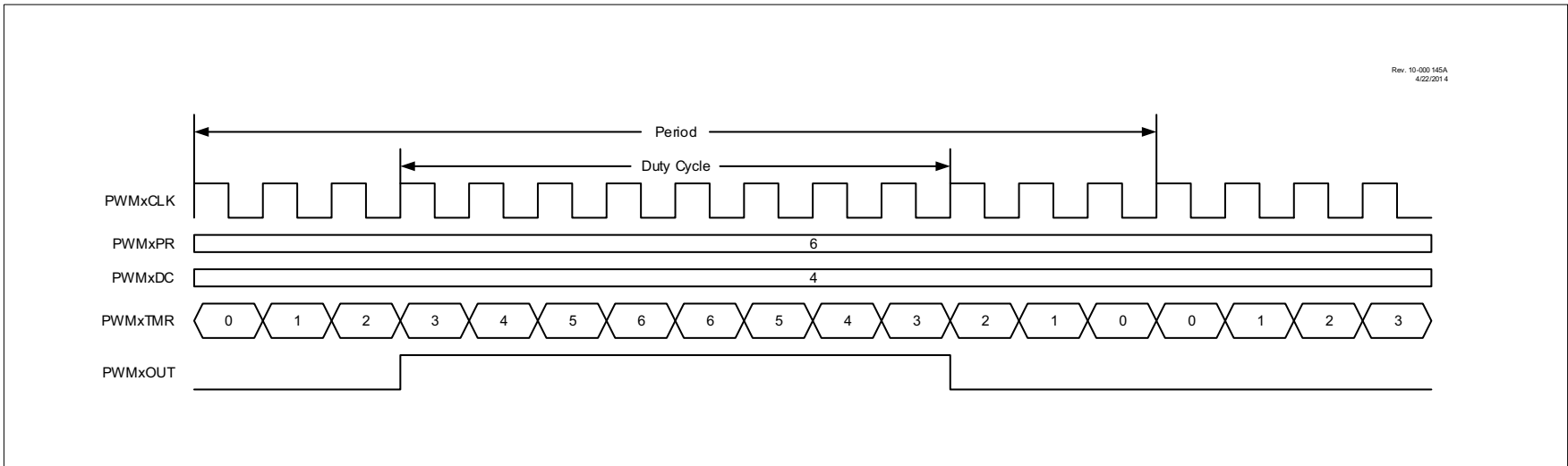

# PIC12(L)F1571/2

## 22.3 Offset Modes

The Offset modes provide the means to adjust the waveform of a slave PWM module relative to the waveform of a master PWM module in the same device.

### 22.3.1 INDEPENDENT RUN MODE

In Independent Run mode ( $OFM\langle 1:0 \rangle = 00$ ), the PWM module is unaffected by the other PWM modules in the device. The PWMxTMR associated with the PWM module in this mode starts counting as soon as the EN bit associated with this PWM module is set and continues counting until the EN bit is cleared. Period events reset the PWMxTMR to zero, after which, the timer continues to count.

A detailed timing diagram of this mode used with Standard PWM mode is shown in [Figure 22-8](#).

### 22.3.2 SLAVE RUN MODE WITH SYNC START

In Slave Run mode with Sync Start ( $OFM\langle 1:0 \rangle = 01$ ), the slave PWMxTMR waits for the master's OFx\_match event. When this event occurs, if the EN bit is set, the PWMxTMR begins counting and continues to count until software clears the EN bit. Slave period events reset the PWMxTMR to zero, after which, the timer continues to count.

A detailed timing diagram of this mode used with Standard PWM mode is shown in [Figure 22-9](#).

### 22.3.3 ONE-SHOT SLAVE MODE WITH SYNC START

In One-Shot Slave mode with Synchronous Start ( $OFM\langle 1:0 \rangle = 10$ ), the slave PWMxTMR waits until the master's OFx\_match event. The timer then begins counting, starting from the value that is already in the timer, and continues to count until the period match event. When the period event occurs, the timer resets to zero and stops counting. The timer then waits until the next master OFx\_match event, after which, it begins counting again to repeat the cycle. An OFx\_match event that occurs before the slave PWM has completed the previously triggered period will be ignored. A slave period that is greater than the master period, but less than twice the master period, will result in a slave output every other master period.

**Note:** During the time the slave timers are resetting to zero, if another offset match event is received, it is possible that the slave PWM would not recognize this match event and the slave timers would fail to begin counting again. This would result in missing duty cycles from the output of the slave PWM. To prevent this from happening, avoid using the same period for both the master and slave PWMs.

A detailed timing diagram of this mode used with Standard PWM mode is shown in [Figure 22-10](#).

### 22.3.4 CONTINUOUS RUN SLAVE MODE WITH SYNC START AND TIMER RESET

In Continuous Run Slave mode with Synchronous Start and Timer Reset ( $OFM\langle 1:0 \rangle = 11$ ), the slave PWMxTMR is inhibited from counting after the slave PWM enable is set. The first master OFx\_match event starts the slave PWMxTMR. Subsequent master OFx\_match events reset the slave PWMxTMR timer value back to 1, after which, the slave PWMxTMR continues to count. The next master OFx\_match event resets the slave PWMxTMR back to 1 to repeat the cycle. Slave period events that occur before the master's OFx\_match event will reset the slave PWMxTMR to zero, after which, the timer will continue to count. Slaves operating in this mode must have a PWMxPH register pair value equal to or greater than 1; otherwise, the phase match event will not occur precluding the start of the PWM output duty cycle.

The offset timing will persist if both the master and slave PWMxPR values are the same, and the Slave Offset mode is changed to Independent Run mode while the PWM module is operating.

A detailed timing diagram of this mode used in Standard PWM mode is shown in [Figure 22-11](#).

**Note:** Unexpected results will occur if the slave PWM\_clock is a higher frequency than the master PWM\_clock.

### 22.3.5 OFFSET MATCH IN CENTER-ALIGNED MODE

When a master is operating in Center-Aligned mode, the offset match event depends on which direction the PWMxTMR is counting. Clearing the OFO bit of the PWMxOFCON register will cause the OFx\_match event to occur when the timer is counting up. Setting the OFO bit of the PWMxOFCON register will cause the OFx\_match event to occur when the timer is counting down. The OFO bit is ignored in non-Center-Aligned modes.

The OFO bit is double-buffered and requires setting the LDA bit to take effect when the PWM module is operating.

Detailed timing diagrams of Center-Aligned mode using offset match control in Independent Slave with Sync Start mode can be seen in [Figure 22-12](#) and [Figure 22-13](#).



**FIGURE 22-8: INDEPENDENT RUN MODE TIMING DIAGRAM**

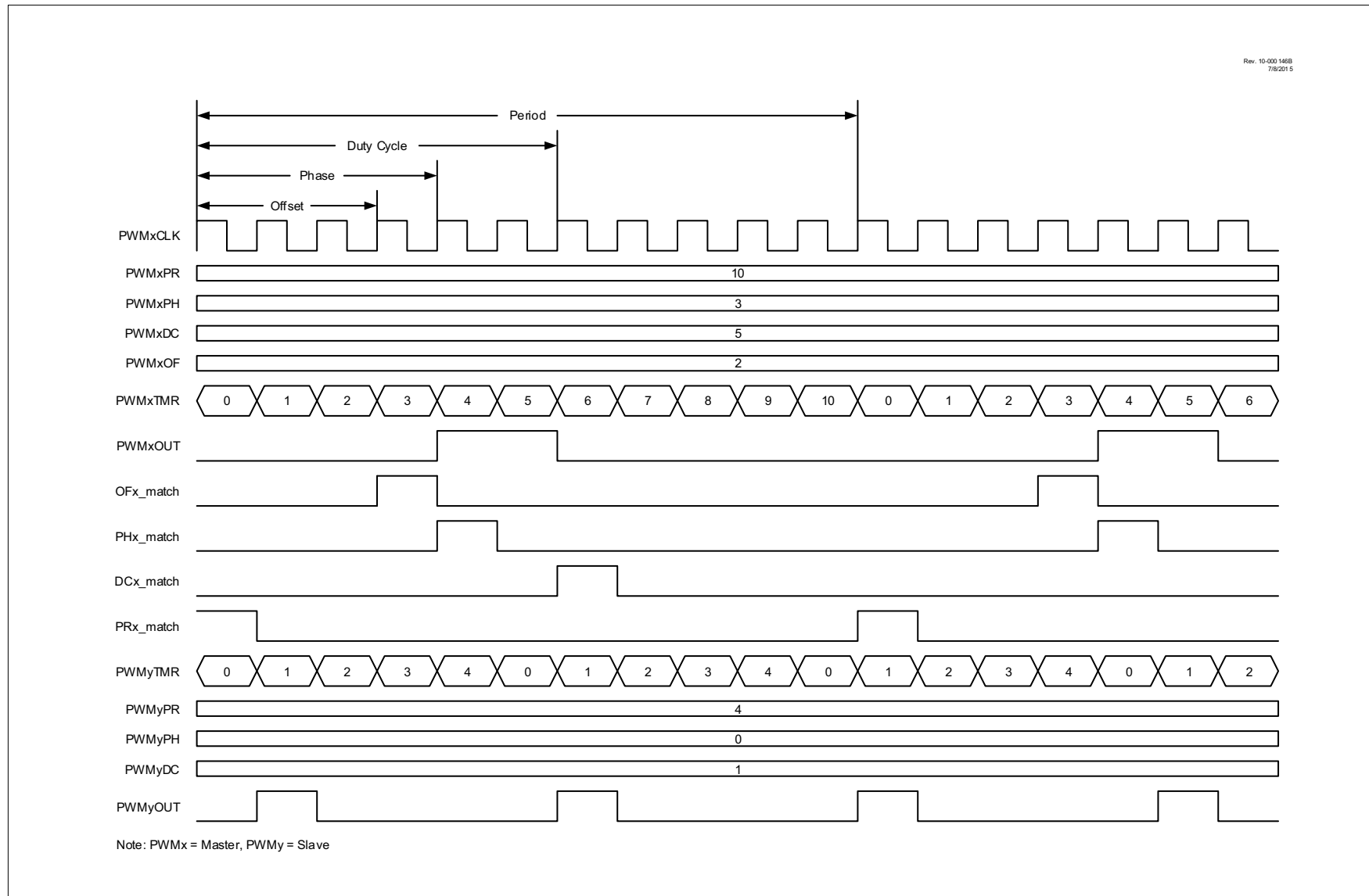

**FIGURE 22-9: SLAVE RUN MODE WITH SYNC START TIMING DIAGRAM**

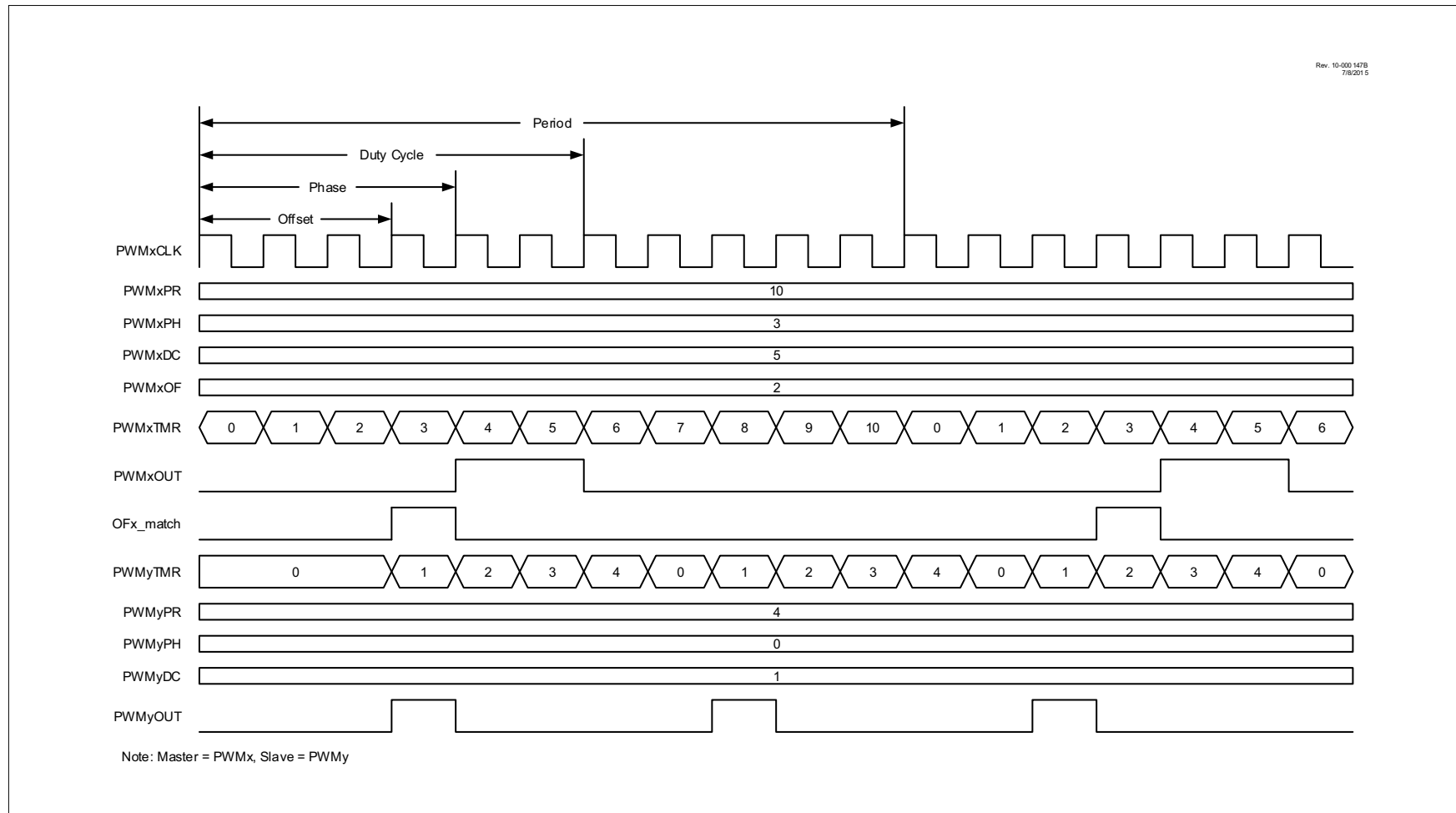

**FIGURE 22-10: ONE-SHOT SLAVE RUN MODE WITH SYNC START TIMING DIAGRAM**

Rev. 10-000 148B  
7/8/2015

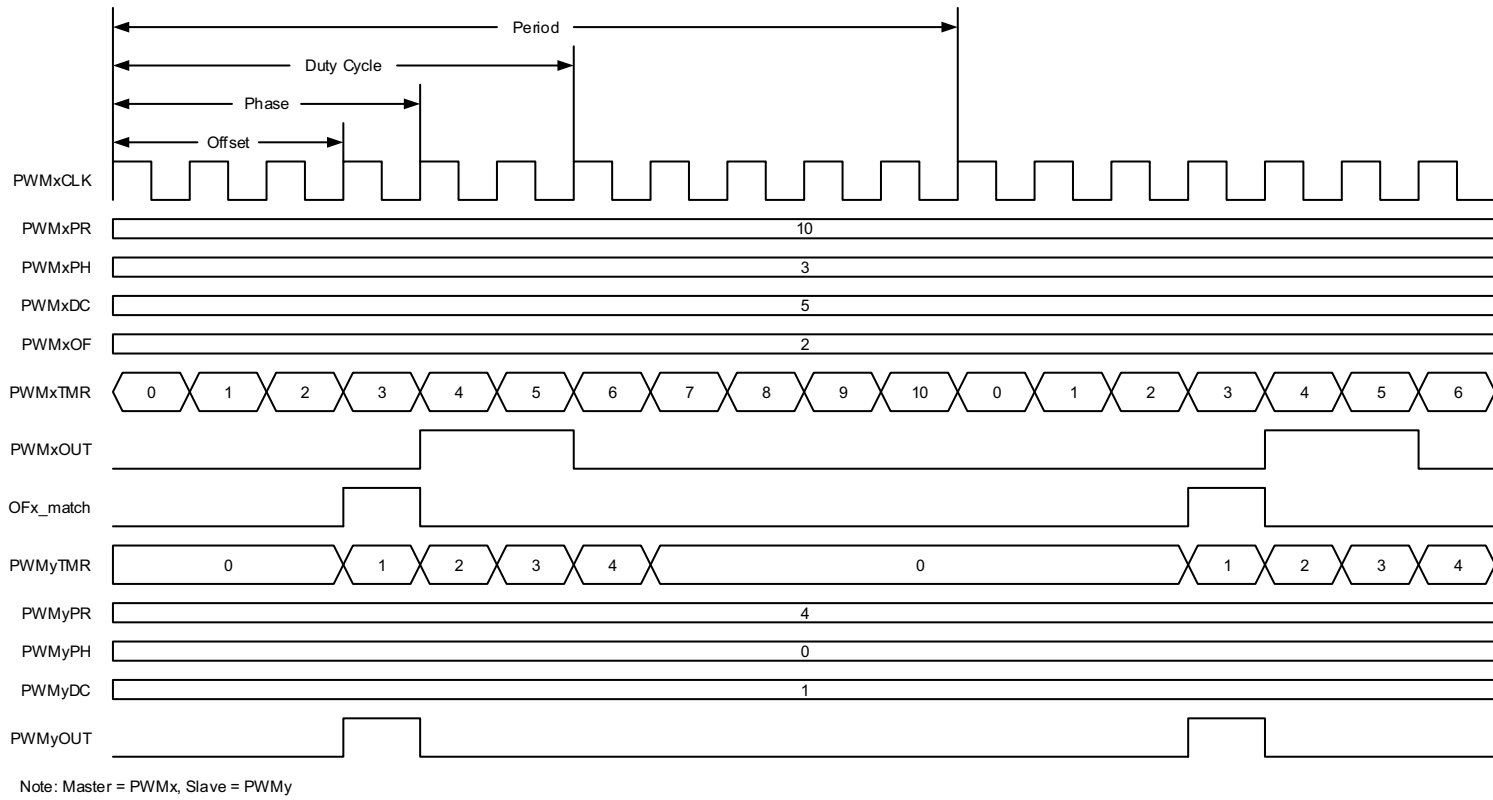
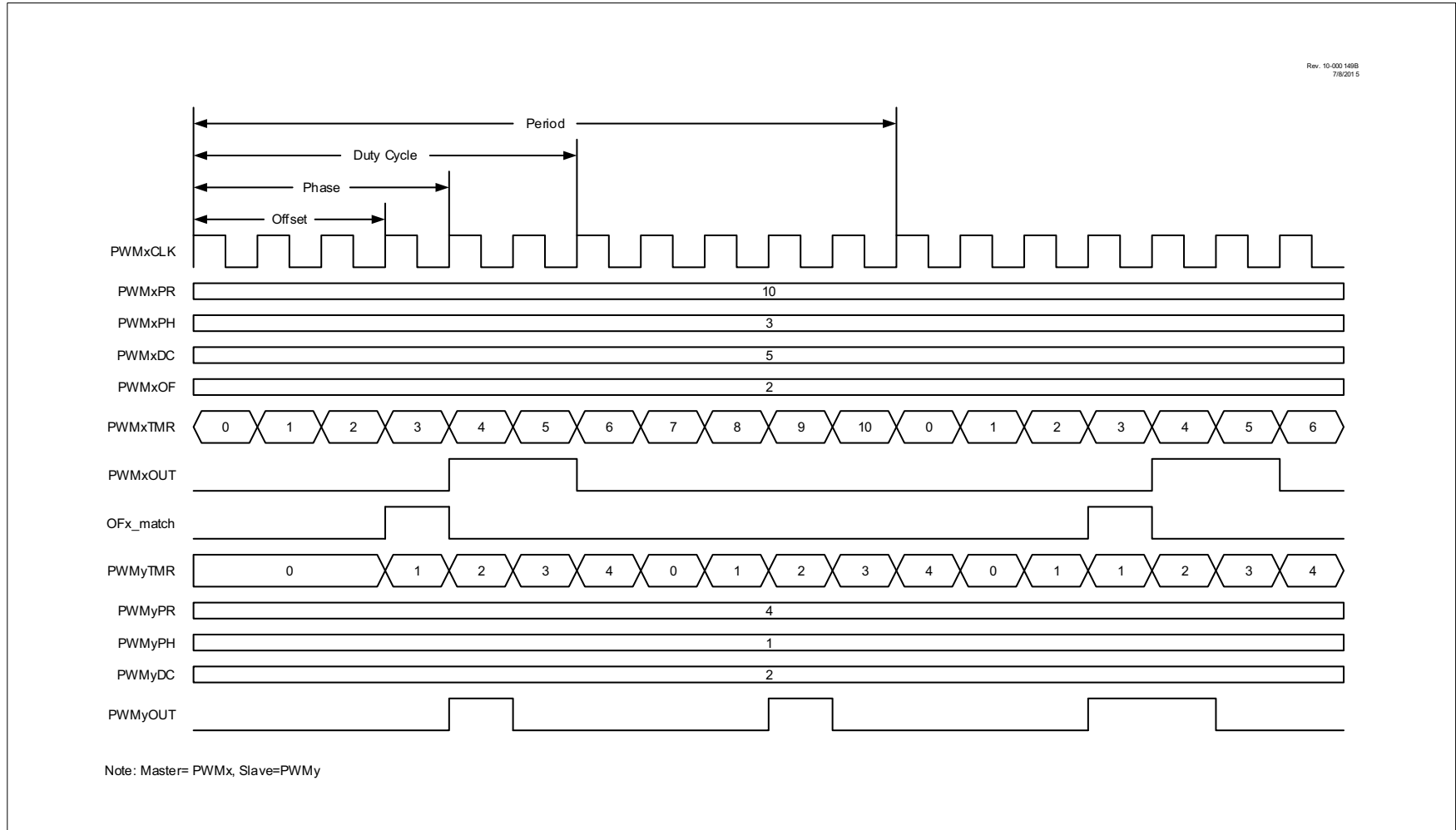
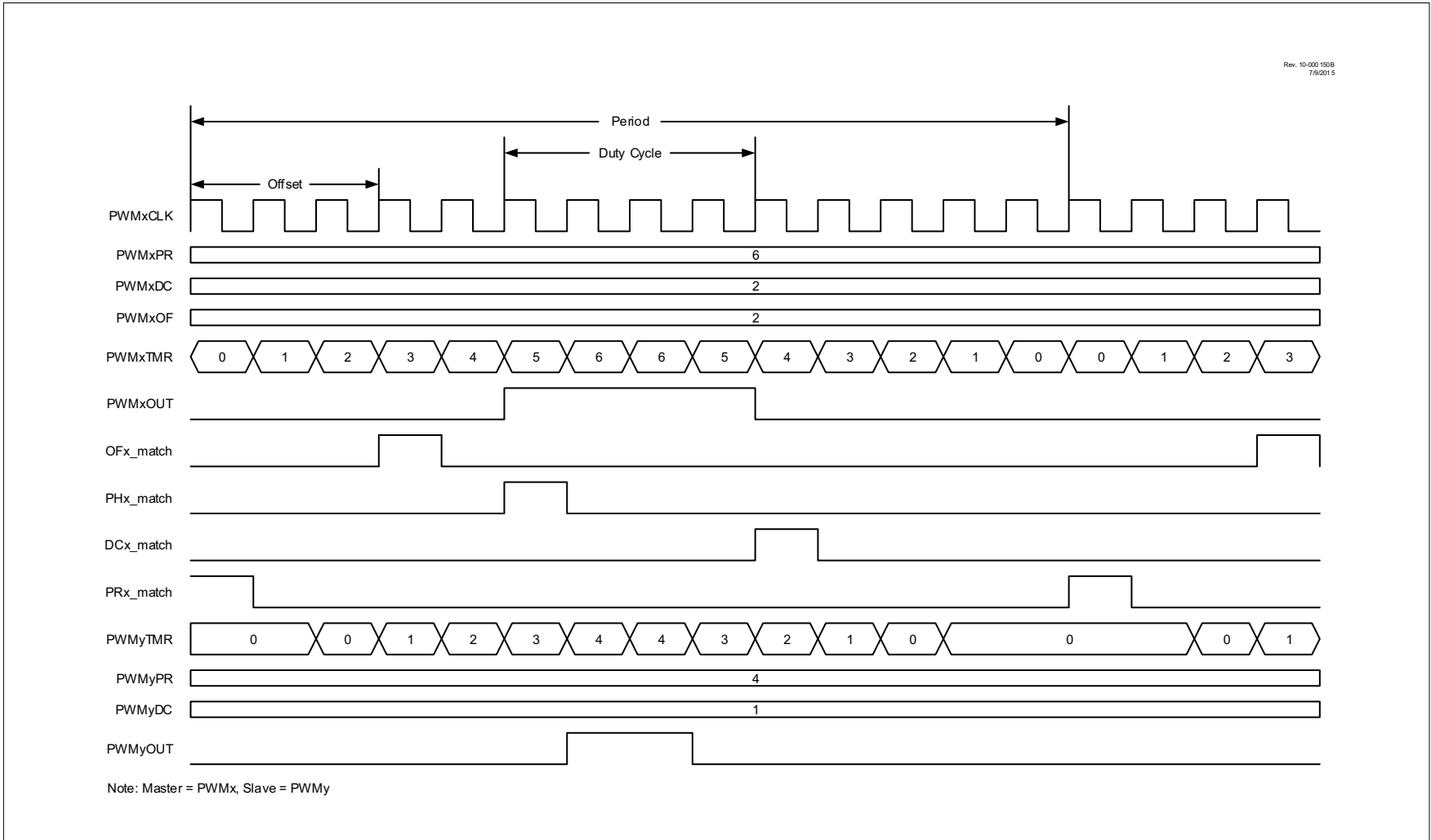

FIGURE 22-11: CONTINUOUS SLAVE RUN MODE WITH IMMEDIATE RESET AND SYNC START TIMING DIAGRAM

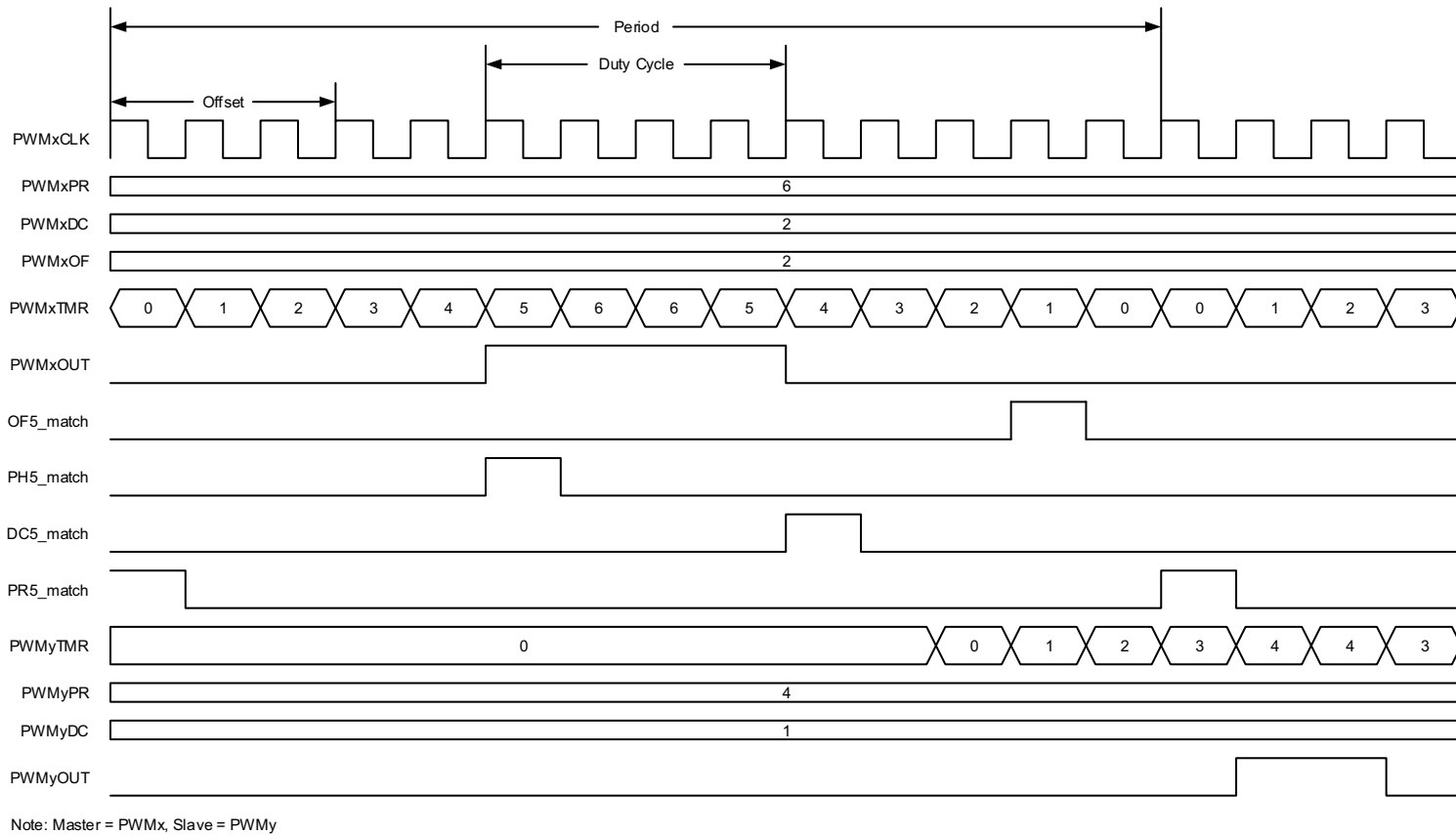

**FIGURE 22-12: OFFSET MATCH ON INCREMENTING TIMER TIMING DIAGRAM**



**FIGURE 22-13: OFFSET MATCH ON DECREMENTING TIMER TIMING DIAGRAM**

Rev. 10-000 151B  
7/9/2015



## 22.4 Reload Operation

Four of the PWM module control register pairs and one control bit are double-buffered so that all can be updated simultaneously. These include:

- PWMxPHH:PWMxPHL register pair
- PWMxDCH:PWMxDCL register pair
- PWMxPRH:PWMxPRL register pair
- PWMxOFH:PWMxOFL register pair
- OFO control bit

When written to, these registers do not immediately affect the operation of the PWM. By default, writes to these registers will not be loaded into the PWM Operating Buffer registers until after the arming conditions are met. The arming control has two methods of operation:

- Immediate
- Triggered

The LDT bit of the PWMxLDCON register controls the arming method. Both methods require the LDA bit to be set. All four buffer pairs will load simultaneously at the loading event.

### 22.4.1 IMMEDIATE RELOAD

When the LDT bit is clear, then the immediate mode is selected and the buffers will be loaded at the first period event after the LDA bit is set. Immediate reloading is used when a PWM module is operating stand-alone or when the PWM module is operating as a master to other slave PWM modules.

### 22.4.2 TRIGGERED RELOAD

When the LDT bit is set, then the Triggered mode is selected and a trigger event is required for the LDA bit to take effect. The trigger source is the buffer load event of one of the other PWM modules in the device. The triggering source is selected by the LDS<1:0> bits of the PWMxLDCON register. The buffers will be loaded at the first period event following the trigger event. Triggered reloading is used when a PWM module is operating as a slave to another PWM and it is necessary to synchronize the buffer reloads in both modules.

**Note 1:** The buffer load operation clears the LDA bit.

- 2: If the LDA bit is set at the same time as PWMxTMR = PWMxPR, the LDA bit is ignored until the next period event. Such is the case when triggered reload is selected and the triggering event occurs simultaneously with the target's period event.

## 22.5 Operation in Sleep Mode

Each PWM module will continue to operate in Sleep mode when either the HFINTOSC or LFINTOSC is selected as the clock source by PWMxCLKCON<1:0>.

## 22.6 Interrupts

Each PWM module has four independent interrupts based on the phase, duty cycle, period and offset match events. The interrupt flag is set on the rising edge of each of these signals. Refer to Figures 22-12 and 22-13 for detailed timing diagrams of the match signals.

# PIC12(L)F1571/2

## 22.7 Register Definitions: PWM Control

Long bit name prefixes for the 16-bit PWM peripherals are shown in Table 22-1. Refer to Section 1.1 “Register and Bit Naming Conventions” for more information

TABLE 22-1: BIT NAME PREFIXES

Peripheral	Bit Name Prefix
PWM1	PWM1
PWM2	PWM2
PWM3	PWM3

### REGISTER 22-1: PWM<sub>x</sub>CON: PWM<sub>x</sub> CONTROL REGISTER

R/W-0/0	R/W-0/0	R/HS/HC-0/0	R/W-0/0	R/W-0/0	R/W-0/0	U-0	U-0
EN	OE	OUT	POL	MODE<1:0>		—	—
bit 7						bit 0	

#### Legend:

HC = Hardware Clearable bit	HS = Hardware Settable bit	
R = Readable bit	W = Writable bit	U = Unimplemented bit, read as ‘0’
‘1’ = Bit is set	‘0’ = Bit is cleared	-n/n = Value at POR and BOR/Value at all other Resets

- bit 7      **EN:** PWM<sub>x</sub> Module Enable bit
  - 1 = Module is enabled
  - 0 = Module is disabled
- bit 6      **OE:** PWM<sub>x</sub> Output Enable bit
  - 1 = PWM output pin is enabled
  - 0 = PWM output pin is disabled
- bit 5      **OUT:** Output State of the PWM<sub>x</sub> Module bit
- bit 4      **POL:** PWM<sub>x</sub> Output Polarity Control bit
  - 1 = PWM output active state is low
  - 0 = PWM output active state is high
- bit 3-2    **MODE<1:0>:** PWM<sub>x</sub> Mode Control bits
  - 11 = Center-Aligned mode
  - 10 = Toggle On Match mode
  - 01 = Set On Match mode
  - 00 = Standard PWM mode
- bit 1-0    **Unimplemented:** Read as ‘0’



## REGISTER 22-2: PWMxINTE: PWMx INTERRUPT ENABLE REGISTER

U-0	U-0	U-0	U-0	R/W-0/0	R/W-0/0	R/W-0/0	R/W-0/0
—	—	—	—	OFIE	PHIE	DCIE	PRIE
bit 7							bit 0

### Legend:

R = Readable bit	W = Writable bit	
u = Bit is unchanged	x = Bit is unknown	U = Unimplemented bit, read as '0'
'1' = Bit is set	'0' = Bit is cleared	-n/n = Value at POR and BOR/Value at all other Resets

- bit 7-4     **Unimplemented:** Read as '0'
- bit 3     **OFIE:** Offset Interrupt Enable bit
  - 1 = Interrupts CPU on offset match
  - 0 = Does not interrupt CPU on offset match
- bit 2     **PHIE:** Phase Interrupt Enable bit
  - 1 = Interrupts CPU on phase match
  - 0 = Does not Interrupt CPU on phase match
- bit 1     **DCIE:** Duty Cycle Interrupt Enable bit
  - 1 = Interrupts CPU on duty cycle match
  - 0 = Does not interrupt CPU on duty cycle match
- bit 0     **PRIE:** Period Interrupt Enable bit
  - 1 = Interrupts CPU on period match
  - 0 = Does not interrupt CPU on period match

# PIC12(L)F1571/2

## REGISTER 22-3: PWMxINTF: PWMx INTERRUPT REQUEST REGISTER

U-0	U-0	U-0	U-0	R/W/HS-0/0	R/W/HS-0/0	R/W/HS-0/0	R/W/HS-0/0
—	—	—	—	OFIF	PHIF	DCIF	PRIF
bit 7							bit 0

### Legend:

HC = Hardware Clearable bit    HS = Hardware Settable bit

R = Readable bit

W = Writable bit

U = Unimplemented bit, read as '0'

'1' = Bit is set

'0' = Bit is cleared

-n/n = Value at POR and BOR/Value at all other Resets

bit 7-4        **Unimplemented:** Read as '0'

bit 3        **OFIF:** Offset Interrupt Flag bit<sup>(1)</sup>

1 = Offset match event occurred

0 = Offset match event did not occur

bit 2        **PHIF:** Phase Interrupt Flag bit<sup>(1)</sup>

1 = Phase match event occurred

0 = Phase match event did not occur

bit 1        **DCIF:** Duty Cycle Interrupt Flag bit<sup>(1)</sup>

1 = Duty cycle match event occurred

0 = Duty cycle match event did not occur

bit 0        **PRIF:** Period Interrupt Flag bit<sup>(1)</sup>

1 = Period match event occurred

0 = Period match event did not occur

**Note 1:** Bit is forced clear by hardware while module is disabled (EN = 0).

## REGISTER 22-4: PWMxCLKCON: PWMx CLOCK CONTROL REGISTER

U-0	R/W-0/0	R/W-0/0	R/W-0/0	U-0	U-0	R/W-0/0	R/W-0/0
—	PS<2:0>			—	—	CS<1:0>	
bit 7							bit 0

### Legend:

R = Readable bit

W = Writable bit

u = Bit is unchanged

x = Bit is unknown

U = Unimplemented bit, read as '0'

'1' = Bit is set

'0' = Bit is cleared

-n/n = Value at POR and BOR/Value at all other Resets

bit 7 **Unimplemented:** Read as '0'

bit 6-4 **PS<2:0>:** Clock Source Prescaler Select bits

111 = Divides clock source by 128

110 = Divides clock source by 64

101 = Divides clock source by 32

100 = Divides clock source by 16

011 = Divides clock source by 8

010 = Divides clock source by 4

001 = Divides clock source by 2

000 = No prescaler

bit 3-2 **Unimplemented:** Read as '0'

bit 1-0 **CS<1:0>:** Clock Source Select bits

11 = Reserved

10 = LFINTOSC (continues to operate during Sleep)

01 = HFINTOSC (continues to operate during Sleep)

00 = FOSC

# PIC12(L)F1571/2

## REGISTER 22-5: PWMxLDCON: PWMx RELOAD TRIGGER SOURCE SELECT REGISTER

R/W-0/0	R/W-0/0	U-0	U-0	U-0	U-0	R/W-0/0	R/W-0/0
LDA <sup>(1)</sup>	LDT	—	—	—	—	LDS<1:0>	
bit 7						bit 0	

### Legend:

R = Readable bit                      W = Writable bit  
u = Bit is unchanged                  x = Bit is unknown                  U = Unimplemented bit, read as '0'  
'1' = Bit is set                            '0' = Bit is cleared                  -n/n = Value at POR and BOR/Value at all other Resets

- bit 7            **LDA:** Load Buffer Armed bit<sup>(1)</sup>  
If LDT = 1:  
1 = Loads the OFx, PHx, DCx and PRx buffers at the end of the period when the selected trigger occurs  
0 = Does not load buffers or load has completed  
If LDT = 0:  
1 = Loads the OFx, PHx, DCx and PRx buffers at the end of the current period  
0 = Does not load buffers or load has completed
- bit 6            **LDT:** Load Buffer on Trigger bit  
1 = Loads buffers on trigger enabled  
0 = Loads buffers on trigger disabled  
Loads the OFx, PHx, DCx and PRx buffers at the end of **every** period after the selected trigger occurs.  
Reloads internal double buffers at the end of current period. The LDS<1:0> bits are ignored.
- bit 5-2        **Unimplemented:** Read as '0'
- bit 1-0        **LDS<1:0>:** Load Trigger Source Select bits  
11 = LD3\_trigger<sup>(2)</sup>  
10 = LD2\_trigger<sup>(2)</sup>  
01 = LD1\_trigger<sup>(2)</sup>  
00 = Reserved

- Note 1:** This bit is cleared by the module after a reload operation. It can be cleared in software to clear an existing arming event.  
**2:** The LD\_trigger corresponding to the PWM used becomes reserved.

## REGISTER 22-6: PWMxOFCON: PWMx OFFSET TRIGGER SOURCE SELECT REGISTER

U-0	R/W-0/0	R/W-0/0	R/W-0/0	U-0	U-0	R/W-0/0	R/W-0/0
—	OFM<1:0>		OFO <sup>(1)</sup>	—	—	OFS<1:0>	
bit 7							bit 0

### Legend:

R = Readable bit	W = Writable bit	
u = Bit is unchanged	x = Bit is unknown	U = Unimplemented bit, read as '0'
'1' = Bit is set	'0' = Bit is cleared	-n/n = Value at POR and BOR/Value at all other Resets

bit 7 **Unimplemented:** Read as '0'

bit 6-5 **OFM<1:0>:** Offset Mode Select bits

11 = Continuous Slave Run mode with immediate Reset and synchronized start when the selected offset trigger occurs

10 = One-Shot Slave Run mode with synchronized start when the selected offset trigger occurs

01 = Independent Slave Run mode with synchronized start when the selected offset trigger occurs

00 = Independent Run mode

bit 4 **OFO:** Offset Match Output Control bit<sup>(1)</sup>

If MODE<1:0> = 11 (PWM Center-Aligned mode):

1 = OFx\_match occurs on counter match when counter decrementing, (second match)

0 = OFx\_match occurs on counter match when counter incrementing, (first match)

If MODE<1:0> = 00, 01 or 10 (all other modes):

Bit is ignored.

bit 3-2 **Unimplemented:** Read as '0'

bit 1-0 **OFS<1:0>:** Offset Trigger Source Select bits

11 = OF3\_match<sup>(1)</sup>

10 = OF2\_match<sup>(1)</sup>

01 = OF1\_match<sup>(1)</sup>

00 = Reserved

**Note 1:** The OFx\_match corresponding to the PWM used becomes reserved.

# PIC12(L)F1571/2

## REGISTER 22-7: PWMxPHH: PWMx PHASE COUNT HIGH REGISTER

R/W-x/u	R/W-x/u	R/W-x/u	R/W-x/u	R/W-x/u	R/W-x/u	R/W-x/u	R/W-x/u
PH<15:8>							
bit 7							bit 0

### Legend:

R = Readable bit

W = Writable bit

u = Bit is unchanged

x = Bit is unknown

U = Unimplemented bit, read as '0'

'1' = Bit is set

'0' = Bit is cleared

-n/n = Value at POR and BOR/Value at all other Resets

bit 7-0      **PH<15:8>**: PWMx Phase High bits  
Upper eight bits of PWM phase count.

## REGISTER 22-8: PWMxPHL: PWMx PHASE COUNT LOW REGISTER

R/W-x/u	R/W-x/u	R/W-x/u	R/W-x/u	R/W-x/u	R/W-x/u	R/W-x/u	R/W-x/u
PH<7:0>							
bit 7							bit 0

### Legend:

R = Readable bit

W = Writable bit

u = Bit is unchanged

x = Bit is unknown

U = Unimplemented bit, read as '0'

'1' = Bit is set

'0' = Bit is cleared

-n/n = Value at POR and BOR/Value at all other Resets

bit 7-0      **PH<7:0>**: PWMx Phase Low bits  
Lower eight bits of PWM phase count.

## REGISTER 22-9: PWMxDCH: PWMx DUTY CYCLE COUNT HIGH REGISTER

R/W-x/u	R/W-x/u	R/W-x/u	R/W-x/u	R/W-x/u	R/W-x/u	R/W-x/u	R/W-x/u
DC<15:8>							
bit 7							bit 0

### Legend:

R = Readable bit	W = Writable bit	
u = Bit is unchanged	x = Bit is unknown	U = Unimplemented bit, read as '0'
'1' = Bit is set	'0' = Bit is cleared	-n/n = Value at POR and BOR/Value at all other Resets

bit 7-0      **DC<15:8>**: PWMx Duty Cycle High bits  
Upper eight bits of PWM duty cycle count.

## REGISTER 22-10: PWMxDCL: PWMx DUTY CYCLE COUNT LOW REGISTER

R/W-x/u	R/W-x/u	R/W-x/u	R/W-x/u	R/W-x/u	R/W-x/u	R/W-x/u	R/W-x/u
DC<7:0>							
bit 7							bit 0

### Legend:

R = Readable bit	W = Writable bit	
u = Bit is unchanged	x = Bit is unknown	U = Unimplemented bit, read as '0'
'1' = Bit is set	'0' = Bit is cleared	-n/n = Value at POR and BOR/Value at all other Resets

bit 7-0      **DC<7:0>**: PWMx Duty Cycle Low bits  
Lower eight bits of PWM duty cycle count.

# PIC12(L)F1571/2

---

## REGISTER 22-11: PWMxPRH: PWMx PERIOD COUNT HIGH REGISTER

R/W-x/u	R/W-x/u	R/W-x/u	R/W-x/u	R/W-x/u	R/W-x/u	R/W-x/u	R/W-x/u
PR<15:8>							
bit 7							bit 0

**Legend:**

R = Readable bit	W = Writable bit	
u = Bit is unchanged	x = Bit is unknown	U = Unimplemented bit, read as '0'
'1' = Bit is set	'0' = Bit is cleared	-n/n = Value at POR and BOR/Value at all other Resets

bit 7-0      **PR<15:8>**: PWMx Period High bits  
Upper eight bits of PWM period count.

## REGISTER 22-12: PWMxPRL: PWMx PERIOD COUNT LOW REGISTER

R/W-x/u	R/W-x/u	R/W-x/u	R/W-x/u	R/W-x/u	R/W-x/u	R/W-x/u	R/W-x/u
PR<7:0>							
bit 7							bit 0

**Legend:**

R = Readable bit	W = Writable bit	
u = Bit is unchanged	x = Bit is unknown	U = Unimplemented bit, read as '0'
'1' = Bit is set	'0' = Bit is cleared	-n/n = Value at POR and BOR/Value at all other Resets

bit 7-0      **PR<7:0>**: PWMx Period Low bits  
Lower eight bits of PWM period count.



## REGISTER 22-13: PWMxOFH: PWMx OFFSET COUNT HIGH REGISTER

R/W-x/u	R/W-x/u	R/W-x/u	R/W-x/u	R/W-x/u	R/W-x/u	R/W-x/u	R/W-x/u
OF<15:8>							
bit 7							bit 0

### Legend:

R = Readable bit	W = Writable bit	
u = Bit is unchanged	x = Bit is unknown	U = Unimplemented bit, read as '0'
'1' = Bit is set	'0' = Bit is cleared	-n/n = Value at POR and BOR/Value at all other Resets

bit 7-0      **OF<15:8>**: PWMx Offset High bits  
Upper eight bits of PWM offset count.

## REGISTER 22-14: PWMxOFL: PWMx OFFSET COUNT LOW REGISTER

R/W-x/u	R/W-x/u	R/W-x/u	R/W-x/u	R/W-x/u	R/W-x/u	R/W-x/u	R/W-x/u
OF<7:0>							
bit 7							bit 0

### Legend:

R = Readable bit	W = Writable bit	
u = Bit is unchanged	x = Bit is unknown	U = Unimplemented bit, read as '0'
'1' = Bit is set	'0' = Bit is cleared	-n/n = Value at POR and BOR/Value at all other Resets

bit 7-0      **OF<7:0>**: PWMx Offset Low bits  
Lower eight bits of PWM offset count.

# PIC12(L)F1571/2

---

## REGISTER 22-15: PWMxTMRH: PWMx TIMER HIGH REGISTER

R/W-x/u	R/W-x/u	R/W-x/u	R/W-x/u	R/W-x/u	R/W-x/u	R/W-x/u	R/W-x/u
TMR<15:8>							
bit 7							bit 0

### Legend:

R = Readable bit	W = Writable bit	
u = Bit is unchanged	x = Bit is unknown	U = Unimplemented bit, read as '0'
'1' = Bit is set	'0' = Bit is cleared	-n/n = Value at POR and BOR/Value at all other Resets

bit 7-0      **TMR<15:8>**: PWMx Timer High bits  
Upper eight bits of PWM timer counter.

## REGISTER 22-16: PWMxTMRL: PWMx TIMER LOW REGISTER

R/W-x/u	R/W-x/u	R/W-x/u	R/W-x/u	R/W-x/u	R/W-x/u	R/W-x/u	R/W-x/u
TMR<7:0>							
bit 7							bit 0

### Legend:

R = Readable bit	W = Writable bit	
u = Bit is unchanged	x = Bit is unknown	U = Unimplemented bit, read as '0'
'1' = Bit is set	'0' = Bit is cleared	-n/n = Value at POR and BOR/Value at all other Resets

bit 7-0      **TMR<7:0>**: PWMx Timer Low bits  
Lower eight bits of PWM timer counter.

**Note:** There are no long and short bit name variants for the following three mirror registers

## REGISTER 22-17: PWMEN: PWMEN BIT ACCESS REGISTER

U-0	U-0	U-0	U-0	U-0	R/W-0/0	R/W-0/0	R/W-0/0
—	—	—	—	—	PWM3EN_A	PWM2EN_A	PWM1EN_A
bit 7						bit 0	

**Legend:**

R = Readable bit                      W = Writable bit  
u = Bit is unchanged                  x = Bit is unknown                  U = Unimplemented bit, read as '0'  
'1' = Bit is set                            '0' = Bit is cleared                  -n/n = Value at POR and BOR/Value at all other Resets

bit 7-3            **Unimplemented:** Read as '0'  
bit 2-0            **PWMxEN\_A:** PWM3/PWM2/PWM1 Enable bits  
Mirror copy of EN bit (PWMxCON<7>).

## REGISTER 22-18: PWMLD: LD BIT ACCESS REGISTER

U-0	U-0	U-0	U-0	U-0	R/W-0/0	R/W-0/0	R/W-0/0
—	—	—	—	—	PWM3LDA_A	PWM2LDA_A	PWM1LDA_A
bit 7						bit 0	

**Legend:**

R = Readable bit                      W = Writable bit  
u = Bit is unchanged                  x = Bit is unknown                  U = Unimplemented bit, read as '0'  
'1' = Bit is set                            '0' = Bit is cleared                  -n/n = Value at POR and BOR/Value at all other Resets

bit 7-3            **Unimplemented:** Read as '0'  
bit 2-0            **PWMxLDA\_A:** PWM3/PWM2/PWM1 LD bits  
Mirror copy of LD bit (PWMxLDCON<7>).

## REGISTER 22-19: PWMOUT: PWMOUT BIT ACCESS REGISTER

U-0	U-0	U-0	U-0	U-0	R/W-0/0	R/W-0/0	R/W-0/0
—	—	—	—	—	PWM3OUT_A	PWM2OUT_A	PWM1OUT_A
bit 7						bit 0	

**Legend:**

R = Readable bit                      W = Writable bit  
u = Bit is unchanged                  x = Bit is unknown                  U = Unimplemented bit, read as '0'  
'1' = Bit is set                            '0' = Bit is cleared                  -n/n = Value at POR and BOR/Value at all other Resets

bit 7-3            **Unimplemented:** Read as '0'  
bit 2-0            **PWMxOUT\_A:** PWM3/PWM2/PWM1 Output bits  
Mirror copy of OUT bit (PWMxCON<5>).

# PIC12(L)F1571/2

**TABLE 22-2: SUMMARY OF REGISTERS ASSOCIATED WITH PWM**

Name	Bit 7	Bit 6	Bit 5	Bit 4	Bit 3	Bit 2	Bit 1	Bit 0	Register on Page
OSCCON	SPLLEN	IRCF<3:0>				—	SCS<1:0>		55
PIE3	—	PWM3IE	PWM2IE	PWM1IE	—	—	—	—	77
PIR3	—	PWM3IF	PWM2IF	PWM1IF	—	—	—	—	80
PWMEN	—	—	—	—	—	PWM3EN_A	PWM2EN_A	PWM1EN_A	227
PWMLD	—	—	—	—	—	PWM3LDA_A	PWM2LDA_A	PWM1LDA_A	227
PWMOUT	—	—	—	—	—	PWM3OUT_A	PWM2OUT_A	PWM1OUT_A	227
PWM1PHL	PH<7:0>								222
PWM1PHH	PH<15:8>								222
PWM1DCL	DC<7:0>								223
PWM1DCH	DC<15:8>								223
PWM1PRH	PR<7:0>								224
PWM1PRL	PR<15:8>								224
PWM1OFH	OF<7:0>								225
PWM1OFL	OF<15:8>								225
PWM1TMRH	TMR<7:0>								226
PWM1TMRL	TMR<15:8>								226
PWM1CON	EN	OE	OUT	POL	MODE<1:0>		—	—	216
PWM1INTE	—	—	—	—	OFIE	PHIE	DCIE	PRIE	217
PWM1INTF	—	—	—	—	OFIF	PHIF	DCIF	PRIF	218
PWM1CLKCON	—	PS<2:0>			—	—	CS<1:0>		219
PWM1LDCON	LDA	LDT	—	—	—	—	LDS<1:0>		220
PWM1OFCON	—	OFM<1:0>		OFO	—	—	OFS<1:0>		221
PWM2PHL	PH<7:0>								222
PWM2PHH	PH<15:8>								222
PWM2DCL	DC<7:0>								223
PWM2DCH	DC<15:8>								223
PWM2PRL	PR<7:0>								224
PWM2PRH	PR<15:8>								224
PWM2OFL	OF<7:0>								225
PWM2OFH	OF<15:8>								225
PWM2TMRL	TMR<7:0>								226
PWM2TMRH	TMR<15:8>								226
PWM2CON	EN	OE	OUT	POL	MODE<1:0>		—	—	216
PWM2INTE	—	—	—	—	OFIE	PHIE	DCIE	PRIE	217
PWM2INTF	—	—	—	—	OFIF	PHIF	DCIF	PRIF	218
PWM2CLKCON	—	PS<2:0>			—	—	CS<1:0>		219
PWM2LDCON	LDA	LDT	—	—	—	—	LDS<1:0>		220
PWM2OFCON	—	OFM<1:0>		OFO	—	—	OFS<1:0>		221
PWM3PHL	PH<7:0>								222
PWM3PHH	PH<15:8>								222
PWM3DCL	DC<7:0>								223
PWM3DCH	DC<15:8>								223
PWM3PRL	PR<7:0>								224
PWM3PRH	PR<15:8>								224
PWM3OFL	OF<7:0>								225
PWM3OFH	OF<15:8>								225
PWM3TMRL	TMR<7:0>								226
PWM3TMRH	TMR<15:8>								226
PWM3CON	EN	OE	OUT	POL	MODE<1:0>		—	—	216

**Legend:** — = unimplemented location, read as '0'. Shaded cells are not used by the PWM.

**TABLE 22-2: SUMMARY OF REGISTERS ASSOCIATED WITH PWM (CONTINUED)**

Name	Bit 7	Bit 6	Bit 5	Bit 4	Bit 3	Bit 2	Bit 1	Bit 0	Register on Page
PWM3INTE	—	—	—	—	OFIE	PHIE	DCIE	PRIE	217
PWM3INTF	—	—	—	—	OFIF	PHIF	DCIF	PRIF	218
PWM3CLKCON	—	PS<2:0>			—	—	CS<1:0>		219
PWM3LDCON	LDA	LDT	—	—	—	—	LDS<1:0>		220
PWM3OFCON	—	OFM<1:0>		OFO	—	—	OFS<1:0>		221

**Legend:** — = unimplemented location, read as '0'. Shaded cells are not used by the PWM.

**TABLE 22-3: SUMMARY OF CONFIGURATION WORD WITH CLOCK SOURCES**

Name	Bits	Bit -/7	Bit -/6	Bit 13/5	Bit 12/4	Bit 11/3	Bit 10/2	Bit 9/1	Bit 8/0	Register on Page
CONFIG1	13:8	—	—	—	—	CLKOUTEN	BOREN<1:0>		—	42
	7:0	CP	MCLRE	PWRTE	WDTE<1:0>	—	FOSC<1:0>		—	

**Legend:** — = unimplemented location, read as '0'. Shaded cells are not used by clock sources.

# PIC12(L)F1571/2

---

NOTES:

## 23.0 COMPLEMENTARY WAVEFORM GENERATOR (CWG) MODULE

The Complementary Waveform Generator (CWG) produces a complementary waveform with dead-band delay from a selection of input sources.

The CWG module has the following features:

- Selectable dead-band clock source control
- Selectable input sources
- Output enable control
- Output polarity control
- Dead-band control with independent 6-bit rising and falling edge dead-band counters
- Auto-shutdown control with:
  - Selectable shutdown sources
  - Auto-restart enable
  - Auto-shutdown pin override control

### 23.1 Fundamental Operation

The CWG generates two output waveforms from the selected input source.

The off-to-on transition of each output can be delayed from the on-to-off transition of the other output, thereby, creating a time delay immediately where neither output is driven. This is referred to as dead time and is covered in [Section 23.5 “Dead-Band Control”](#). A typical operating waveform with dead band, generated from a single input signal, is shown in [Figure 23-2](#).

It may be necessary to guard against the possibility of circuit Faults or a feedback event arriving too late, or not at all. In this case, the active drive must be terminated before the Fault condition causes damage. This is referred to as auto-shutdown and is covered in [Section 23.9 “Auto-Shutdown Control”](#).

### 23.2 Clock Source

The CWG module allows the following clock sources to be selected:

- Fosc (system clock)
- HFINTOSC (16 MHz only)

The clock sources are selected using the G1CS0 bit of the CWGxCON0 register ([Register 23-1](#)).

## 23.3 Selectable Input Sources

The CWG generates the output waveforms from the input sources in [Table 23-1](#).

**TABLE 23-1: SELECTABLE INPUT SOURCES**

Source Peripheral	Signal Name
Comparator C1	C1OUT_sync
PWM1	PWM1_output
PWM2	PWM2_output
PWM3	PWM3_output

The input sources are selected using the GxIS<2:0> bits in the CWGxCON1 register ([Register 23-2](#)).

## 23.4 Output Control

Immediately after the CWG module is enabled, the complementary drive is configured with both CWGxA and CWGxB drives cleared.

### 23.4.1 OUTPUT ENABLES

Each CWG output pin has individual output enable control. Output enables are selected with the GxOEA and GxOEB bits of the CWGxCON0 register. When an output enable control is cleared, the module asserts no control over the pin. When an output enable is set, the override value or active PWM waveform is applied to the pin per the port priority selection. The output pin enables are dependent on the module enable bit, GxEN. When GxEN is cleared, CWG output enables and CWG drive levels have no effect.

### 23.4.2 POLARITY CONTROL

The polarity of each CWG output can be selected independently. When the output polarity bit is set, the corresponding output is active-high. Clearing the output polarity bit configures the corresponding output as active-low. However, polarity does not affect the override levels. Output polarity is selected with the GxPOLA and GxPOLB bits of the CWGxCON0 register.

FIGURE 23-1: SIMPLIFIED CWG BLOCK DIAGRAM

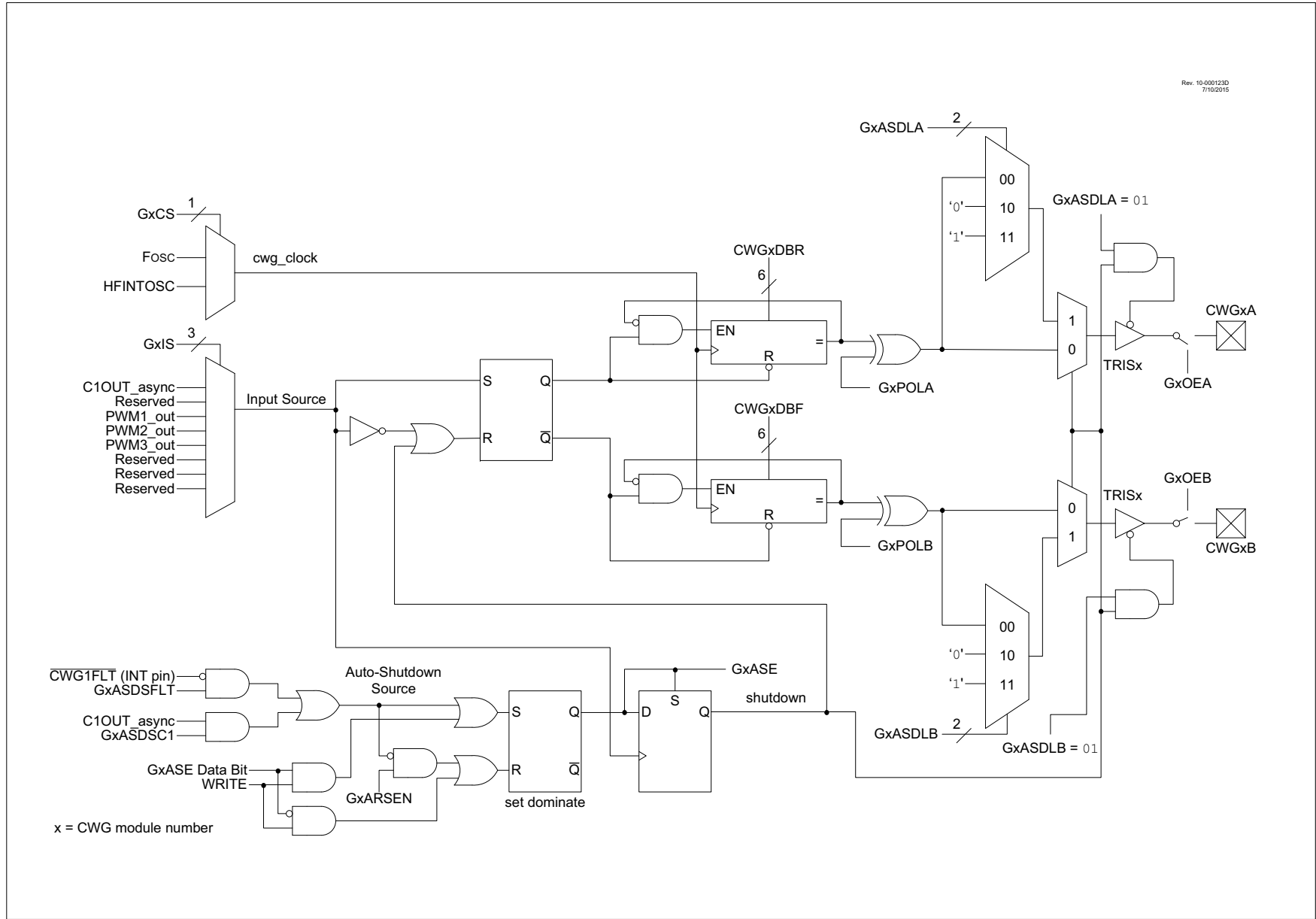



**FIGURE 23-2: TYPICAL CWG OPERATION WITH PWM1 (NO AUTO-SHUTDOWN)**

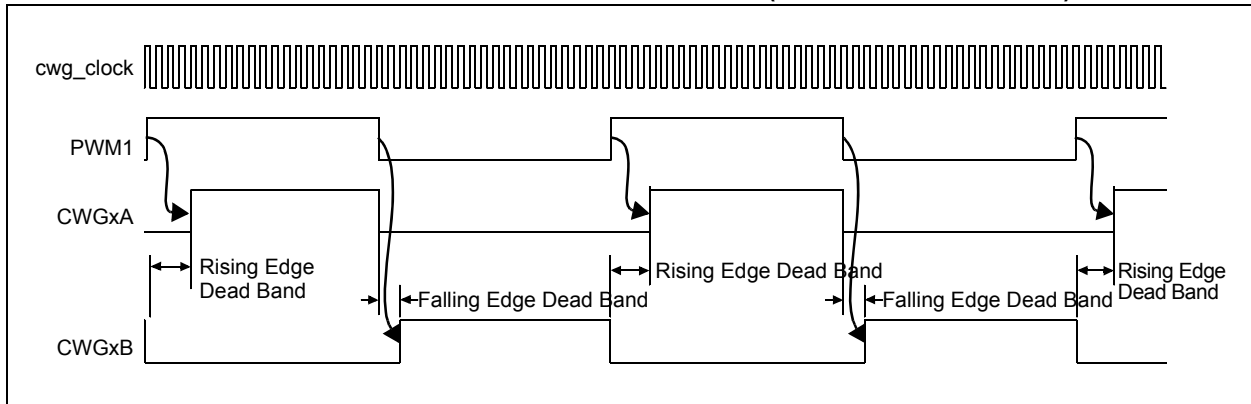

## 23.5 Dead-Band Control

Dead-band control provides for non-overlapping output signals to prevent shoot-through current in power switches. The CWG contains two 6-bit dead-band counters. One dead-band counter is used for the rising edge of the input source control. The other is used for the falling edge of the input source control.

Dead band is timed by counting CWG clock periods from zero, up to the value in the rising or falling Dead-Band Counter registers. See the CWGxDBR and CWGxDBF registers ([Register 23-4](#) and [Register 23-5](#), respectively).

## 23.6 Rising Edge Dead Band

The rising edge dead band delays the turn-on of the CWGxA output from when the CWGxB output is turned off. The rising edge dead-band time starts when the rising edge of the input source signal goes true. When this happens, the CWGxB output is immediately turned off and the rising edge dead-band delay time starts. When the rising edge dead-band delay time is reached, the CWGxA output is turned on.

The CWGxDBR register sets the duration of the dead-band interval on the rising edge of the input source signal. This duration is from 0 to 64 counts of dead band.

Dead band is always counted off the edge on the input source signal. A count of 0 (zero), indicates that no dead band is present.

If the input source signal is not present for enough time for the count to be completed, no output will be seen on the respective output.

## 23.7 Falling Edge Dead Band

The falling edge dead band delays the turn-on of the CWGxB output from when the CWGxA output is turned off. The falling edge dead-band time starts when the falling edge of the input source goes true. When this happens, the CWGxA output is immediately turned off and the falling edge dead-band delay time starts. When the falling edge dead-band delay time is reached, the CWGxB output is turned on.

The CWGxDBF register sets the duration of the dead-band interval on the falling edge of the input source signal. This duration is from 0 to 64 counts of dead band.

Dead band is always counted off the edge on the input source signal. A count of 0 (zero), indicates that no dead band is present.

If the input source signal is not present for enough time for the count to be completed, no output will be seen on the respective output.

Refer to [Figure 23-3](#) and [Figure 23-4](#) for examples.

**FIGURE 23-3: DEAD-BAND OPERATION, CWGxDBR = 01h, CWGxDBF = 02h**

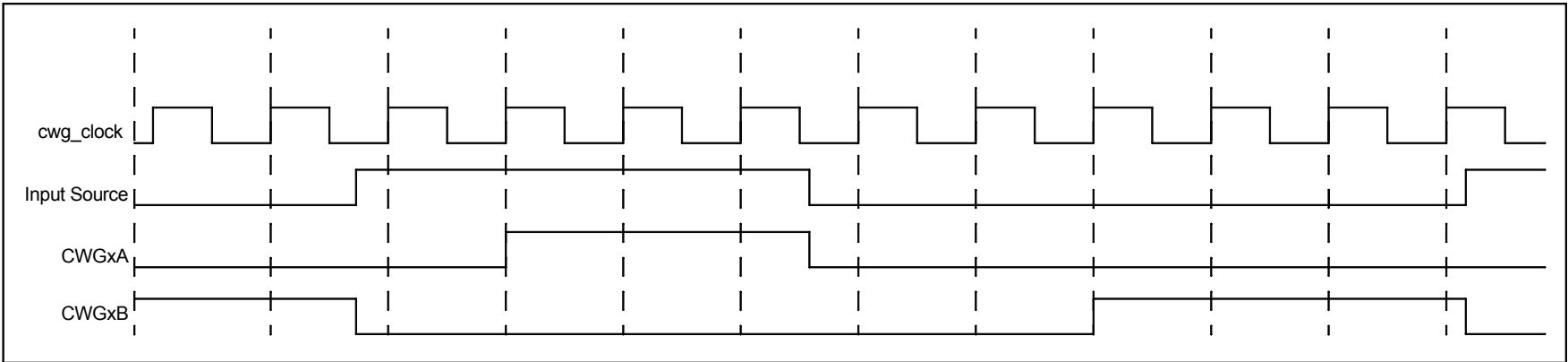

**FIGURE 23-4: DEAD-BAND OPERATION, CWGxDBR = 03h, CWGxDBF = 04h, SOURCE SHORTER THAN DEAD BAND**

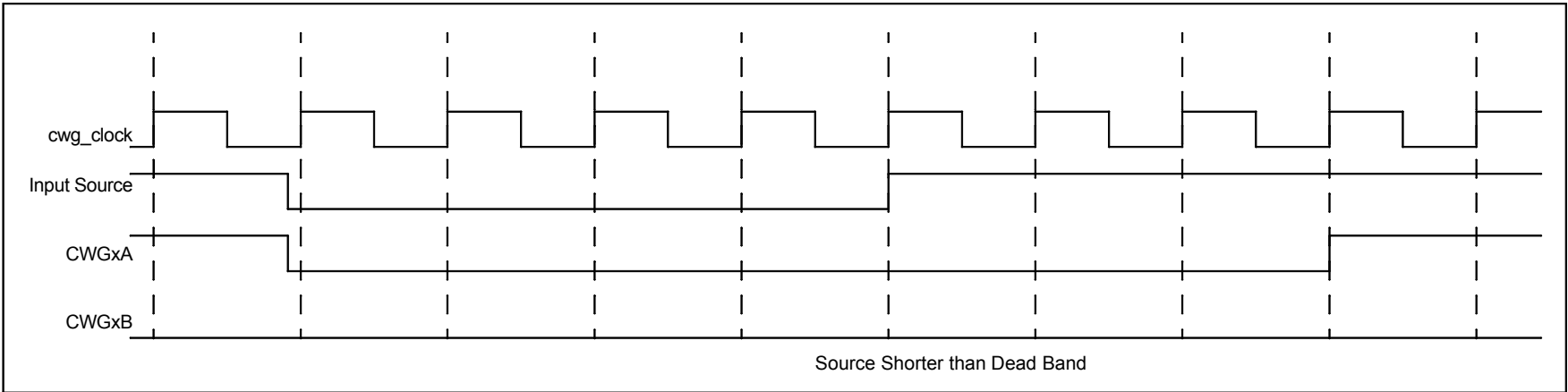

## 23.8 Dead-Band Uncertainty

When the rising and falling edges of the input source triggers the dead-band counters, the input may be asynchronous. This will create some uncertainty in the dead-band time delay. The maximum uncertainty is equal to one CWG clock period. Refer to [Equation 23-1](#) for more detail.

### EQUATION 23-1: DEAD-BAND UNCERTAINTY

$$T_{DEADBAND\_UNCERTAINTY} = \frac{1}{F_{cwg\_clock}}$$

Example:

$$F_{cwg\_clock} = 16 \text{ MHz}$$

Therefore:

$$\begin{aligned} T_{DEADBAND\_UNCERTAINTY} &= \frac{1}{F_{cwg\_clock}} \\ &= \frac{1}{16 \text{ MHz}} \\ &= 62.5 \text{ ns} \end{aligned}$$

## 23.9 Auto-Shutdown Control

Auto-shutdown is a method to immediately override the CWG output levels with specific overrides that allow for safe shutdown of the circuit. The shutdown state can be either cleared automatically or held until cleared by software.

### 23.9.1 SHUTDOWN

The shutdown state can be entered by either of the following two methods:

- Software generated
- External Input

#### 23.9.1.1 Software Generated Shutdown

Setting the GxASE bit of the CWGxCON2 register will force the CWG into the shutdown state.

When auto-restart is disabled, the shutdown state will persist as long as the GxASE bit is set.

When auto-restart is enabled, the GxASE bit will clear automatically and resume operation on the next rising edge event. See [Figure 23-6](#).

#### 23.9.1.2 External Input Source

External shutdown inputs provide the fastest way to safely suspend CWG operation in the event of a Fault condition. When any of the selected shutdown inputs goes active, the CWG outputs will immediately go to the selected override levels without software delay. Any combination of two input sources can be selected to cause a shutdown condition. The sources are:

- Comparator C1 – C1OUT\_async
- $\overline{\text{CWG1FLT}}$

Shutdown inputs are selected in the CWGxCON2 register ([Register 23-3](#)).

**Note:** Shutdown inputs are level sensitive, not edge sensitive. The shutdown state cannot be cleared, except by disabling auto-shutdown, as long as the shutdown input level persists.

## 23.10 Operation During Sleep

The CWG module operates independently from the system clock, and will continue to run during Sleep provided that the clock and input sources selected remain active.

The HFINTOSC remains active during Sleep, provided that the CWG module is enabled, the input source is active and the HFINTOSC is selected as the clock source, regardless of the system clock source selected.

In other words, if the HFINTOSC is simultaneously selected as the system clock and the CWG clock source, when the CWG is enabled and the input source is active, the CPU will go idle during Sleep, but the CWG will continue to operate and the HFINTOSC will remain active.

This will have a direct effect on the Sleep mode current.

## 23.11 Configuring the CWG

The following steps illustrate how to properly configure the CWG to ensure a synchronous start:

1. Ensure that the TRISx control bits corresponding to CWGxA and CWGxB are set so that both are configured as inputs.
2. Clear the GxEN bit if not already cleared.
3. Set desired dead-band times with the CWGxDBR and CWGxDBF registers.
4. Set up the following controls in the CWGxCON2 auto-shutdown register:
  - Select desired shutdown source.
  - Select both output overrides to the desired levels (this is necessary even if not using auto-shutdown because start-up will be from a shutdown state).
  - Set the GxASE bit and clear the GxARSEN bit.
5. Select the desired input source using the CWGxCON1 register.
6. Configure the following controls in the CWGxCON0 register:
  - Select desired clock source.
  - Select the desired output polarities.
  - Set the output enables for the outputs to be used.
7. Set the GxEN bit.
8. Clear the TRISx control bits corresponding to CWGxA and CWGxB to be used to configure those pins as outputs.
9. If auto-restart is to be used, set the GxARSEN bit and the GxASE bit will be cleared automatically. Otherwise, clear the GxASE bit to start the CWG.

### 23.11.1 PIN OVERRIDE LEVELS

The levels driven to the output pins, while the shutdown input is true, are controlled by the GxASDLA and GxASDLB bits of the CWGxCON1 register ([Register 23-3](#)). GxASDLA controls the CWG1A override level and GxASDLB controls the CWG1B override level. The control bit logic level corresponds to the output logic drive level while in the shutdown state. The polarity control does not apply to the override level.

### 23.11.2 AUTO-SHUTDOWN RESTART

After an auto-shutdown event has occurred, there are two ways to resume operation:

- Software controlled
- Auto-restart

The restart method is selected with the GxARSEN bit of the CWGxCON2 register. Waveforms of software controlled and automatic restarts are shown in [Figure 23-5](#) and [Figure 23-6](#).

#### 23.11.2.1 Software Controlled Restart

When the GxARSEN bit of the CWGxCON2 register is cleared, the CWG must be restarted after an auto-shutdown event by software.

Clearing the shutdown state requires all selected shutdown inputs to be low, otherwise, the GxASE bit will remain set. The overrides will remain in effect until the first rising edge event after the GxASE bit is cleared. The CWG will then resume operation.

#### 23.11.2.2 Auto-Restart

When the GxARSEN bit of the CWGxCON2 register is set, the CWG will restart from the auto-shutdown state automatically.

The GxASE bit will clear automatically when all shutdown sources go low. The overrides will remain in effect until the first rising edge event after the GxASE bit is cleared. The CWG will then resume operation.

**FIGURE 23-5: SHUTDOWN FUNCTIONALITY, AUTO-RESTART DISABLED ( $GxARSEN = 0$ ,  $GxASDLA = 01$ ,  $GxASDLB = 01$ )**

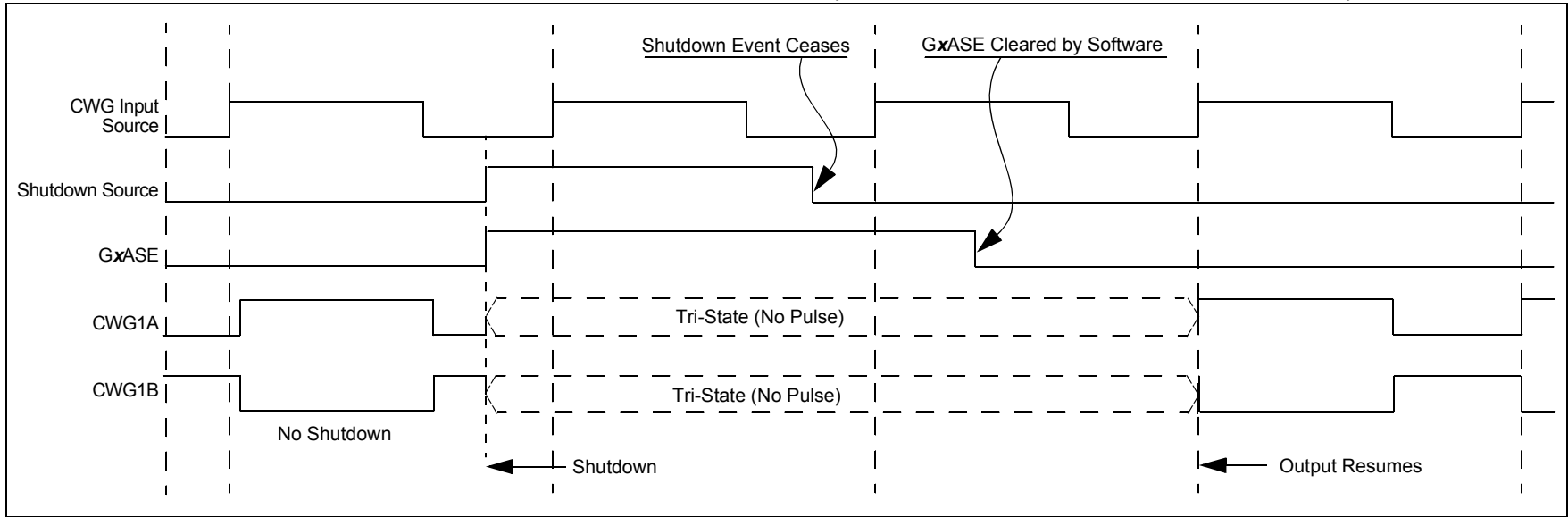

**FIGURE 23-6: SHUTDOWN FUNCTIONALITY, AUTO-RESTART ENABLED ( $GxARSEN = 1$ ,  $GxASDLA = 01$ ,  $GxASDLB = 01$ )**

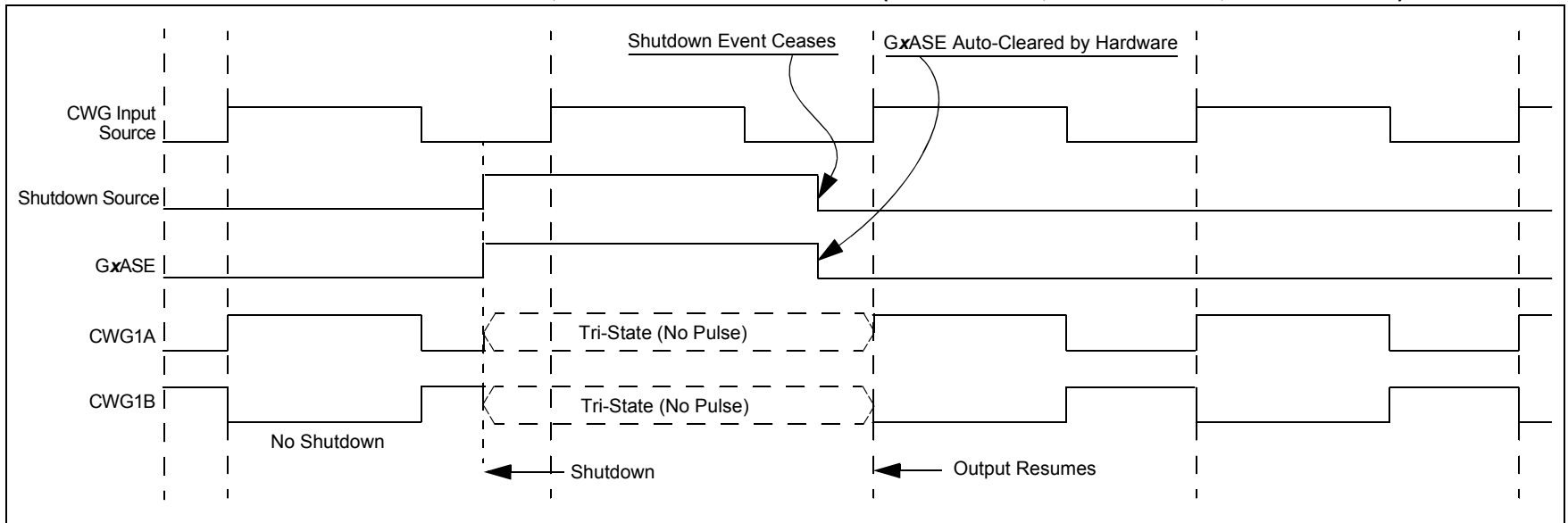

# PIC12(L)F1571/2

## 23.12 Register Definitions: CWG Control

### REGISTER 23-1: CWGxCON0: CWGx CONTROL REGISTER 0

R/W-0/0	R/W-0/0	R/W-0/0	R/W-0/0	R/W-0/0	U-0	U-0	R/W-0/0
GxEN	GxOEB	GxOEA	GxPOLB	GxPOLA	—	—	GxCS0
bit 7							bit 0

#### Legend:

R = Readable bit

W = Writable bit

u = Bit is unchanged

x = Bit is unknown

U = Unimplemented bit, read as '0'

'1' = Bit is set

'0' = Bit is cleared

-n/n = Value at POR and BOR/Value at all other Resets

- bit 7      **GxEN:** CWGx Enable bit  
1 = Module is enabled  
0 = Module is disabled
- bit 6      **GxOEB:** CWGxB Output Enable bit  
1 = CWGxB is available on appropriate I/O pin  
0 = CWGxB is not available on appropriate I/O pin
- bit 5      **GxOEA:** CWGxA Output Enable bit  
1 = CWGxA is available on appropriate I/O pin  
0 = CWGxA is not available on appropriate I/O pin
- bit 4      **GxPOLB:** CWGxB Output Polarity bit  
1 = Output is inverted polarity  
0 = Output is normal polarity
- bit 3      **GxPOLA:** CWGxA Output Polarity bit  
1 = Output is inverted polarity  
0 = Output is normal polarity
- bit 2-1    **Unimplemented:** Read as '0'
- bit 0      **GxCS0:** CWGx Clock Source Select bit  
1 = HFINTOSC  
0 = Fosc

## REGISTER 23-2: CWGxCON1: CWGx CONTROL REGISTER 1

R/W-x/u	R/W-x/u	R/W-x/u	R/W-x/u	U-0	R/W-0/0	R/W-0/0	R/W-0/0
GxASDLB<1:0>		GxASDLA<1:0>		—	GxIS<2:0>		
bit 7							bit 0

### Legend:

R = Readable bit

W = Writable bit

u = Bit is unchanged

x = Bit is unknown

U = Unimplemented bit, read as '0'

'1' = Bit is set

'0' = Bit is cleared

-n/n = Value at POR and BOR/Value at all other Resets

- bit 7-6      **GxASDLB<1:0>**: CWGx Shutdown State for CWGxB bits  
When an Auto-Shutdown Event is Present (GxASE = 1):  
 11 = CWGxB pin is driven to '1', regardless of the setting of the GxPOLB bit  
 10 = CWGxB pin is driven to '0', regardless of the setting of the GxPOLB bit  
 01 = CWGxB pin is tri-stated  
 00 = CWGxB pin is driven to its inactive state after the selected dead-band interval; GxPOLB will still control the polarity of the output
- bit 5-4      **GxASDLA<1:0>**: CWGx Shutdown State for CWGxA bits  
When an Auto-Shutdown Event is Present (GxASE = 1):  
 11 = CWGxA pin is driven to '1', regardless of the setting of the GxPOLA bit  
 10 = CWGxA pin is driven to '0', regardless of the setting of the GxPOLA bit  
 01 = CWGxA pin is tri-stated  
 00 = CWGxA pin is driven to its inactive state after the selected dead-band interval; GxPOLA will still control the polarity of the output
- bit 3        **Unimplemented**: Read as '0'
- bit 2-0      **GxIS<2:0>**: CWGx Input Source Select bits  
 111 = Reserved  
 110 = Reserved  
 101 = Reserved  
 100 = PWM3 – PWM3\_out  
 011 = PWM2 – PWM2\_out  
 010 = PWM1 – PWM1\_out  
 001 = Reserved  
 000 = Comparator C1 – C1OUT\_async

# PIC12(L)F1571/2

## REGISTER 23-3: CWGxCON2: CWGx CONTROL REGISTER 2

R/W-0/0	R/W-0/0	U-0	U-0	U-0	R/W-0/0	R/W-0/0	U-0
GxASE	GxARSEN	—	—	—	GxASDSC1	GxASDSFLT	—
bit 7							bit 0

### Legend:

R = Readable bit	W = Writable bit	
u = Bit is unchanged	x = Bit is unknown	U = Unimplemented bit, read as '0'
'1' = Bit is set	'0' = Bit is cleared	-n/n = Value at POR and BOR/Value at all other Resets

- bit 7      **GxASE:** Auto-Shutdown Event Status bit  
1 = An auto-shutdown event has occurred  
0 = No auto-shutdown event has occurred
- bit 6      **GxARSEN:** Auto-Restart Enable bit  
1 = Auto-restart is enabled  
0 = Auto-restart is disabled
- bit 5-3    **Unimplemented:** Read as '0'
- bit 2      **GxASDSC1:** CWGx Auto-Shutdown on Comparator C1 Enable bit  
1 = Shutdown when Comparator C1 output (C1OUT\_async) is high  
0 = Comparator C1 output has no effect on shutdown
- bit 1      **GxASDSFLT:** CWGx Auto-Shutdown on FLT Enable bit  
1 = Shutdown when  $\overline{\text{CWG1FLT}}$  input is low  
0 =  $\overline{\text{CWG1FLT}}$  input has no effect on shutdown
- bit 0      **Unimplemented:** Read as '0'



**REGISTER 23-4: CWGxDBR: CWGx COMPLEMENTARY WAVEFORM GENERATOR RISING DEAD-BAND COUNT REGISTER**

U-0	U-0	R/W-x/u	R/W-x/u	R/W-x/u	R/W-x/u	R/W-x/u	R/W-x/u
—	—	CWGxDBR<5:0>					
bit 7							bit 0

**Legend:**

R = Readable bit	W = Writable bit	U = Unimplemented bit, read as '0'
u = Bit is unchanged	x = Bit is unknown	-n/n = Value at POR and BOR/Value at all other Resets
'1' = Bit is set	'0' = Bit is cleared	q = Value depends on condition

bit 7-6      **Unimplemented:** Read as '0'

bit 5-0      **CWGxDBR<5:0>:** Complementary Waveform Generator (CWGx) Rising Counts bits

- 11 1111 = 63-64 counts of dead band
- 11 1110 = 62-63 counts of dead band
- 
- 
- 
- 00 0010 = 2-3 counts of dead band
- 00 0001 = 1-2 counts of dead band
- 00 0000 = 0 counts of dead band

**REGISTER 23-5: CWGxDBF: CWGx COMPLEMENTARY WAVEFORM GENERATOR FALLING DEAD-BAND COUNT REGISTER**

U-0	U-0	R/W-x/u	R/W-x/u	R/W-x/u	R/W-x/u	R/W-x/u	R/W-x/u
—	—	CWGxDBF<5:0>					
bit 7							bit 0

**Legend:**

R = Readable bit	W = Writable bit	U = Unimplemented bit, read as '0'
u = Bit is unchanged	x = Bit is unknown	-n/n = Value at POR and BOR/Value at all other Resets
'1' = Bit is set	'0' = Bit is cleared	q = Value depends on condition

bit 7-6      **Unimplemented:** Read as '0'

bit 5-0      **CWGxDBF<5:0>:** Complementary Waveform Generator (CWGx) Falling Counts bits

- 11 1111 = 63-64 counts of dead band
- 11 1110 = 62-63 counts of dead band
- 
- 
- 
- 00 0010 = 2-3 counts of dead band
- 00 0001 = 1-2 counts of dead band
- 00 0000 = 0 counts of dead band; dead-band generation is bypassed

# PIC12(L)F1571/2

**TABLE 23-2: SUMMARY OF REGISTERS ASSOCIATED WITH CWG**

Name	Bit 7	Bit 6	Bit 5	Bit 4	Bit 3	Bit 2	Bit 1	Bit 0	Register on Page
ANSELA	—	—	—	ANSA4	—	ANSA2	ANSA1	ANSA0	<a href="#">114</a>
CWG1CON0	G1EN	G1OEB	G1OEA	G1POLB	G1POLA	—	—	G1CS0	<a href="#">238</a>
CWG1CON1	G1ASDLB<1:0>		G1ASDLA<1:0>		—	—	G1IS<1:0>		<a href="#">239</a>
CWG1CON2	G1ASE	G1ARSEN	—	—	—	G1ASDSC1	G1ASDSFLT	—	<a href="#">240</a>
CWG1DBF	—	—	CWG1DBF<5:0>						<a href="#">241</a>
CWG1DBR	—	—	CWG1DBR<5:0>						<a href="#">241</a>
TRISA	—	—	TRISA<5:4>		— <sup>(1)</sup>	TRISA2	TRISA<1:0>		<a href="#">113</a>

**Legend:** — = unimplemented location, read as '0'. Shaded cells are not used by the CWG.

**Note 1:** Unimplemented, read as '1'.

## 24.0 IN-CIRCUIT SERIAL PROGRAMMING™ (ICSP™)

ICSP™ programming allows customers to manufacture circuit boards with unprogrammed devices. Programming can be done after the assembly process, allowing the device to be programmed with the most recent firmware or a custom firmware. Five pins are needed for ICSP™ programming:

- ICSPCLK
- ICSPDAT
- $\overline{\text{MCLR}}/\text{VPP}$
- VDD
- VSS

In Program/Verify mode, the program memory, User IDs and the Configuration Words are programmed through serial communications. The ICSPDAT pin is a bidirectional I/O used for transferring the serial data and the ICSPCLK pin is the clock input. For more information on ICSP™, refer to the “PIC12(L)F1501/PIC16(L)F150X Memory Programming Specification” (DS41573).

### 24.1 High-Voltage Programming Entry Mode

The device is placed into High-Voltage Programming Entry mode by holding the ICSPCLK and ICSPDAT pins low, then raising the voltage on  $\overline{\text{MCLR}}/\text{VPP}$  to  $V_{\text{IH}}$ .

### 24.2 Low-Voltage Programming Entry Mode

The Low-Voltage Programming Entry mode allows the PIC® MCUs (Flash) to be programmed using VDD only, without high voltage. When the LVP bit of the Configuration Words is set to ‘1’, the ICSP Low-Voltage Programming Entry mode is enabled. To disable the Low-Voltage ICSP mode, the LVP bit must be programmed to ‘0’.

Entry into the Low-Voltage Programming Entry mode requires the following steps:

1.  $\overline{\text{MCLR}}$  is brought to  $V_{\text{IL}}$ .
2. A 32-bit key sequence is presented on ICSPDAT while clocking ICSPCLK.

Once the key sequence is complete,  $\overline{\text{MCLR}}$  must be held at  $V_{\text{IL}}$  for as long as Program/Verify mode is to be maintained.

If Low-Voltage Programming is enabled ( $\text{LVP} = 1$ ), the  $\overline{\text{MCLR}}$  Reset function is automatically enabled and cannot be disabled. See [Section 6.5 “MCLR”](#) for more information.

The LVP bit can only be reprogrammed to ‘0’ by using the High-Voltage Programming mode.

## 24.3 Common Programming Interfaces

Connection to a target device is typically done through an ICSP™ header. A commonly found connector on development tools is the RJ-11 in the 6P6C (6-pin, 6-connector) configuration. See [Figure 24-1](#).

**FIGURE 24-1: ICD RJ-11 STYLE CONNECTOR INTERFACE**

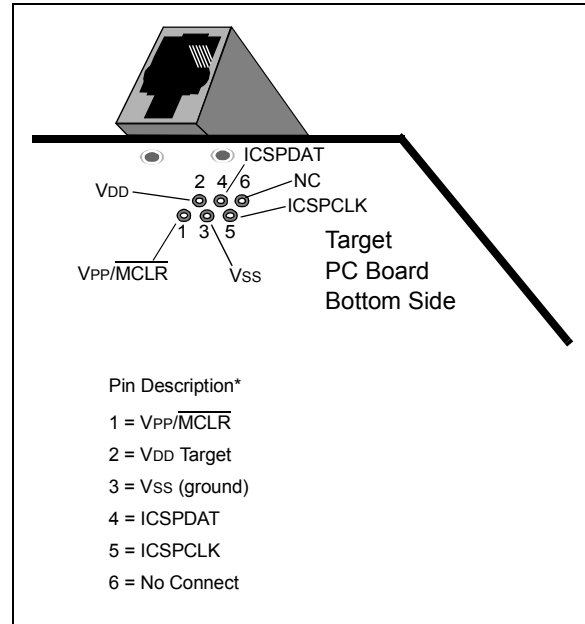

Another connector often found in use with the PICkit™ programmers is a standard 6-pin header with 0.1 inch spacing. Refer to [Figure 24-2](#).

# PIC12(L)F1571/2

**FIGURE 24-2: PICKit™ PROGRAMMER STYLE CONNECTOR INTERFACE**

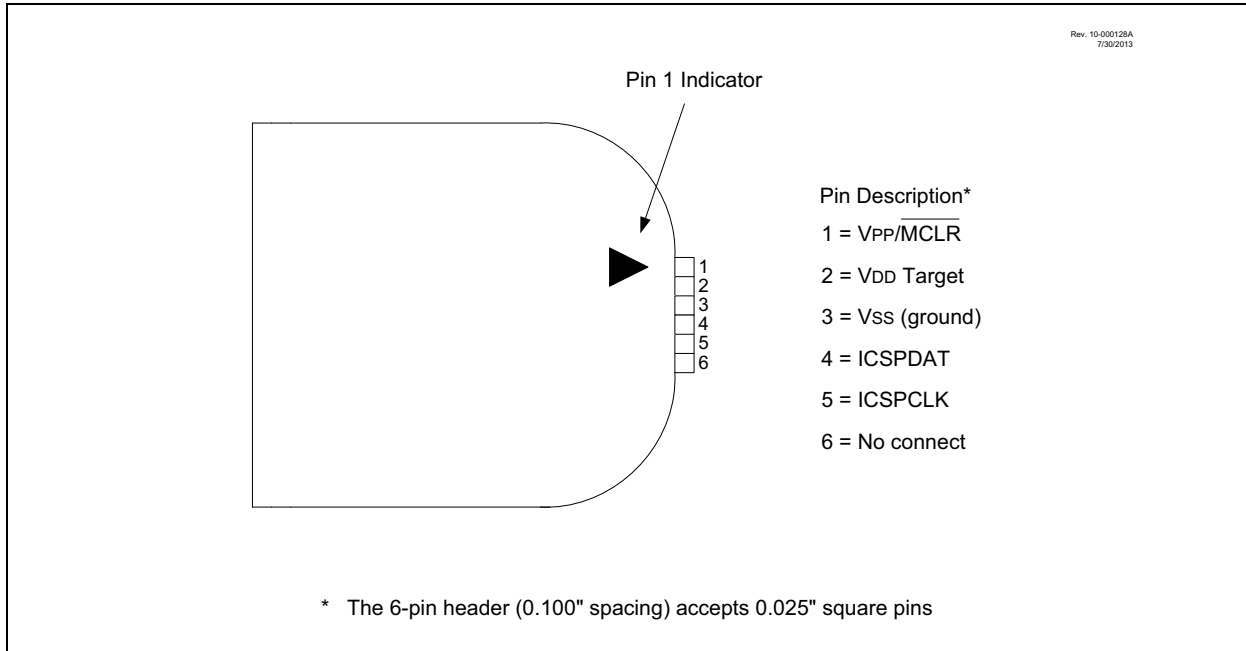

For additional interface recommendations, refer to your specific device programmer manual prior to PCB design.

It is recommended that isolation devices be used to separate the programming pins from other circuitry. The type of isolation is highly dependent on the specific application and may include devices, such as resistors, diodes or even jumpers. See [Figure 24-3](#) for more information.

**FIGURE 24-3: TYPICAL CONNECTION FOR ICSP™ PROGRAMMING**

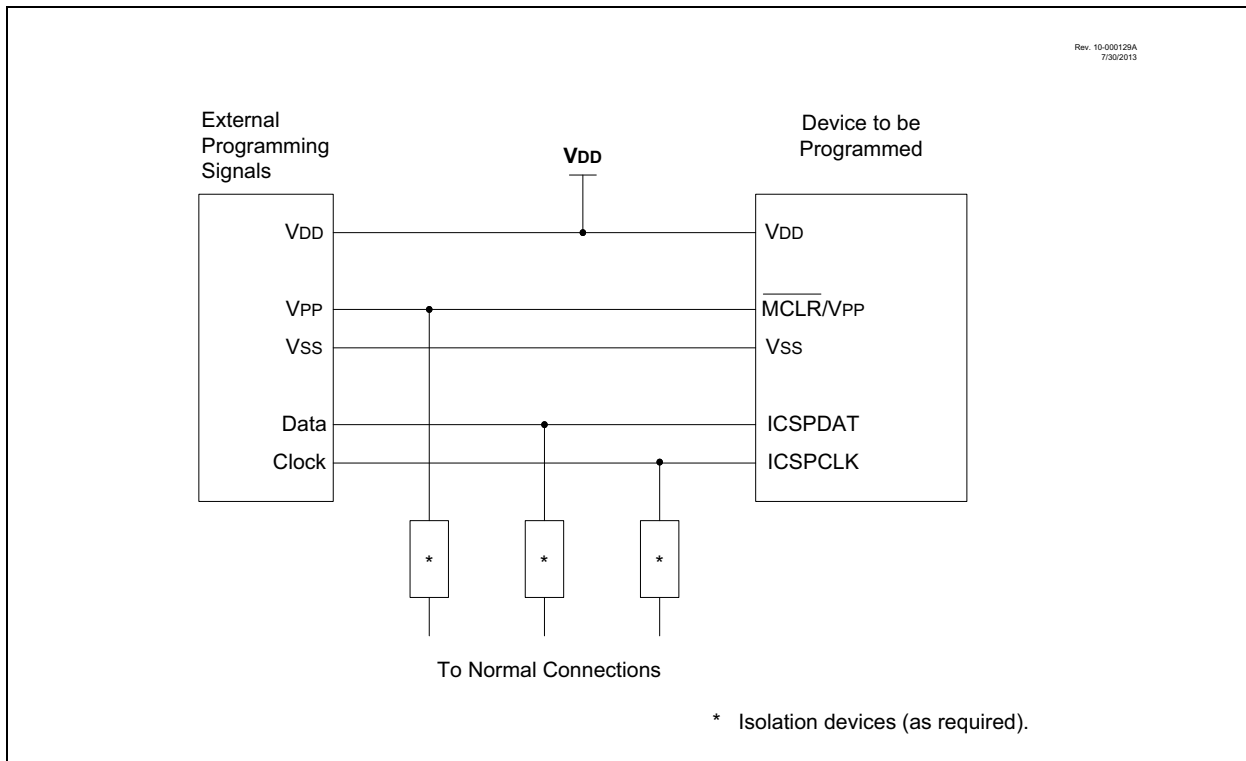

## 25.0 INSTRUCTION SET SUMMARY

Each instruction is a 14-bit word containing the operation code (opcode) and all required operands. The opcodes are broken into three broad categories.

- Byte-Oriented
- Bit-Oriented
- Literal and Control

The literal and control category contains the most varied instruction word format.

Table 25-3 lists the instructions recognized by the MPASM™ assembler.

All instructions are executed within a single instruction cycle, with the following exceptions, which may take two or three cycles:

- Subroutine takes two cycles (*CALL*, *CALLW*)
- Returns from interrupts or subroutines take two cycles (*RETURN*, *RETLW*, *RETFIE*)
- Program branching takes two cycles (*GOTO*, *BRA*, *BRW*, *BTFSS*, *BTFSC*, *DECFSZ*, *INCSFZ*)
- One additional instruction cycle will be used when any instruction references an indirect file register and the file select register is pointing to program memory

One instruction cycle consists of 4 oscillator cycles; for an oscillator frequency of 4 MHz, this gives a nominal instruction execution rate of 1 MHz.

All instruction examples use the format '0xhh' to represent a hexadecimal number, where 'h' signifies a hexadecimal digit.

## 25.1 Read-Modify-Write Operations

Any instruction that specifies a file register as part of the instruction performs a Read-Modify-Write (R-M-W) operation. The register is read, the data is modified and the result is stored according to either the instruction or the destination designator, 'd'. A read operation is performed on a register even if the instruction writes to that register.

**TABLE 25-1: OPCODE FIELD DESCRIPTIONS**

Field	Description
f	Register file address (0x00 to 0x7F).
W	Working register (accumulator).
b	Bit address within an 8-bit file register.
k	Literal field, constant data or label.
x	Don't care location (= 0 or 1). The assembler will generate code with x = 0. It is the recommended form of use for compatibility with all Microchip software tools.
d	Destination select; d = 0: store result in W, d = 1: store result in file register f. Default is d = 1.
n	FSR or INDF number (0-1).
mm	Pre-Post Increment-Decrement mode selection.

**TABLE 25-2: ABBREVIATION DESCRIPTIONS**

Field	Description
PC	Program Counter
$\overline{TO}$	Time-out bit
C	Carry bit
DC	Digit Carry bit
Z	Zero bit
$\overline{PD}$	Power-Down bit

# PIC12(L)F1571/2

**FIGURE 25-1: GENERAL FORMAT FOR INSTRUCTIONS**

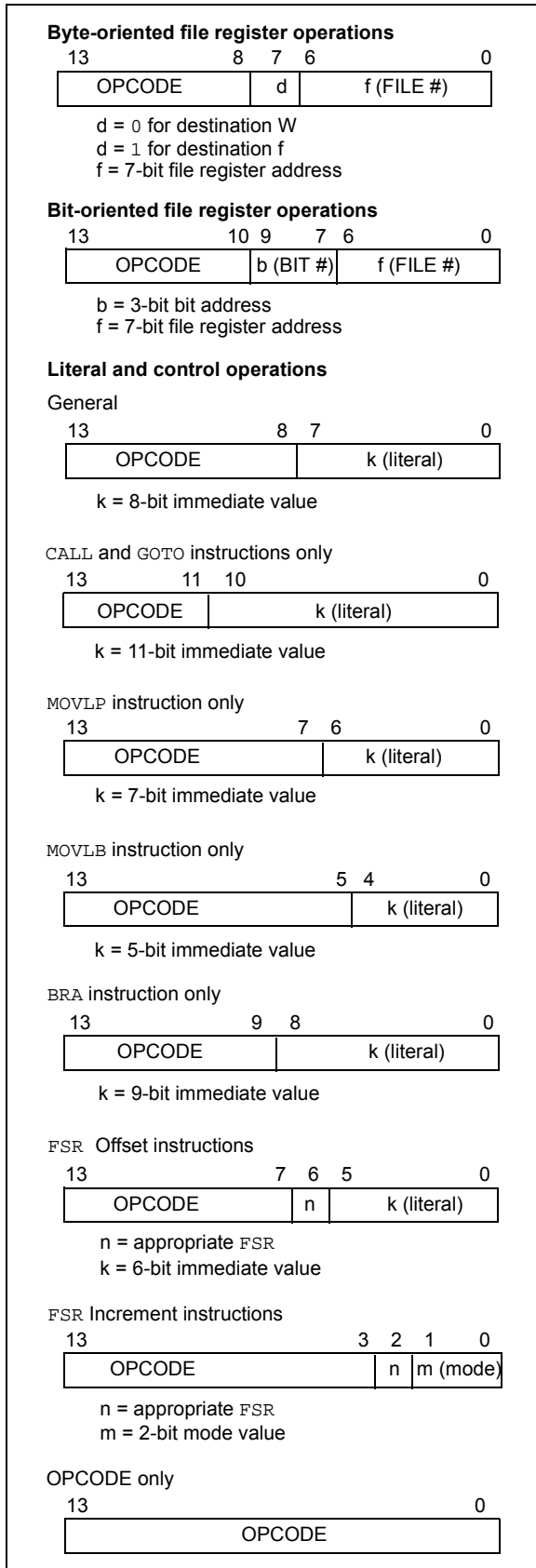

**TABLE 25-3: ENHANCED MID-RANGE INSTRUCTION SET**

Mnemonic, Operands	Description	Cycles	14-Bit Opcode				Status Affected	Notes	
			MSb	LSb					
<b>BYTE-ORIENTED FILE REGISTER OPERATIONS</b>									
ADDWF	f, d	Add W and f	1	00	0111	dfff	ffff	C, DC, Z	2
ADDWFC	f, d	Add with Carry W and f	1	11	1101	dfff	ffff	C, DC, Z	2
ANDWF	f, d	AND W with f	1	00	0101	dfff	ffff	Z	2
ASRF	f, d	Arithmetic Right Shift	1	11	0111	dfff	ffff	C, Z	2
LSLF	f, d	Logical Left Shift	1	11	0101	dfff	ffff	C, Z	2
LSRF	f, d	Logical Right Shift	1	11	0110	dfff	ffff	C, Z	2
CLRF	f	Clear f	1	00	0001	1fff	ffff	Z	2
CLRW	–	Clear W	1	00	0001	0000	00xx	Z	
COMF	f, d	Complement f	1	00	1001	dfff	ffff	Z	2
DECf	f, d	Decrement f	1	00	0011	dfff	ffff	Z	2
INCF	f, d	Increment f	1	00	1010	dfff	ffff	Z	2
IORWF	f, d	Inclusive OR W with f	1	00	0100	dfff	ffff	Z	2
MOVF	f, d	Move f	1	00	1000	dfff	ffff	Z	2
MOVWF	f	Move W to f	1	00	0000	1fff	ffff		2
RLF	f, d	Rotate Left f through Carry	1	00	1101	dfff	ffff	C	2
RRF	f, d	Rotate Right f through Carry	1	00	1100	dfff	ffff	C	2
SUBWF	f, d	Subtract W from f	1	00	0010	dfff	ffff	C, DC, Z	2
SUBWFB	f, d	Subtract with Borrow W from f	1	11	1011	dfff	ffff	C, DC, Z	2
SWAPF	f, d	Swap nibbles in f	1	00	1110	dfff	ffff		2
XORWF	f, d	Exclusive OR W with f	1	00	0110	dfff	ffff	Z	2
<b>BYTE-ORIENTED SKIP OPERATIONS</b>									
DECFSZ	f, d	Decrement f, Skip if 0	1(2)	00	1011	dfff	ffff		1, 2
INCFSZ	f, d	Increment f, Skip if 0	1(2)	00	1111	dfff	ffff		1, 2
<b>BIT-ORIENTED FILE REGISTER OPERATIONS</b>									
BCF	f, b	Bit Clear f	1	01	00bb	bfff	ffff		2
BSF	f, b	Bit Set f	1	01	01bb	bfff	ffff		2
<b>BIT-ORIENTED SKIP OPERATIONS</b>									
BTFSC	f, b	Bit Test f, Skip if Clear	1 (2)	01	10bb	bfff	ffff		1, 2
BTFSS	f, b	Bit Test f, Skip if Set	1 (2)	01	11bb	bfff	ffff		1, 2
<b>LITERAL OPERATIONS</b>									
ADDLW	k	Add literal and W	1	11	1110	kkkk	kkkk	C, DC, Z	
ANDLW	k	AND literal with W	1	11	1001	kkkk	kkkk	Z	
IORLW	k	Inclusive OR literal with W	1	11	1000	kkkk	kkkk	Z	
MOVLB	k	Move literal to BSR	1	00	0000	001k	kkkk		
MOVLP	k	Move literal to PCLATH	1	11	0001	1kkk	kkkk		
MOVLW	k	Move literal to W	1	11	0000	kkkk	kkkk		
SUBLW	k	Subtract W from literal	1	11	1100	kkkk	kkkk	C, DC, Z	
XORLW	k	Exclusive OR literal with W	1	11	1010	kkkk	kkkk	Z	

- Note 1:** If the Program Counter (PC) is modified, or a conditional test is true, the instruction requires two cycles. The second cycle is executed as a NOP.
- 2:** If this instruction addresses an INDF register and the MSb of the corresponding FSR is set, this instruction will require one additional instruction cycle.
- 3:** See the table in the MOVWF and MOVWI instruction descriptions.

# PIC12(L)F1571/2

**TABLE 25-3: ENHANCED MID-RANGE INSTRUCTION SET (CONTINUED)**

Mnemonic, Operands	Description	Cycles	14-Bit Opcode			Status Affected	Notes		
			MSb	LSb					
<b>CONTROL OPERATIONS</b>									
BRA	k	Relative Branch	2	11	001k	kkkk	kkkk		
BRW	–	Relative Branch with W	2	00	0000	0000	1011		
CALL	k	Call Subroutine	2	10	0kkk	kkkk	kkkk		
CALLW	–	Call Subroutine with W	2	00	0000	0000	1010		
GOTO	k	Go to address	2	10	1kkk	kkkk	kkkk		
RETFIE	k	Return from interrupt	2	00	0000	0000	1001		
RETLW	k	Return with literal in W	2	11	0100	kkkk	kkkk		
RETURN	–	Return from Subroutine	2	00	0000	0000	1000		
<b>INHERENT OPERATIONS</b>									
CLRWDT	–	Clear Watchdog Timer	1	00	0000	0110	0100	$\overline{TO}$ , $\overline{PD}$	
NOP	–	No Operation	1	00	0000	0000	0000		
OPTION	–	Load OPTION_REG register with W	1	00	0000	0110	0010		
RESET	–	Software device Reset	1	00	0000	0000	0001		
SLEEP	–	Go into Standby mode	1	00	0000	0110	0011	$\overline{TO}$ , $\overline{PD}$	
TRIS	f	Load TRIS register with W	1	00	0000	0110	0fff		
<b>C COMPILER OPTIMIZED</b>									
ADDFSR	n, k	Add Literal k to FSRn	1	11	0001	0nkk	kkkk		
MOVIW	n mm	Move Indirect FSRn to W with pre/post inc/dec modifier, mm	1	00	0000	0001	0nmm kkkk	Z	<b>2, 3</b>
MOVWI	k[n]	Move INDFn to W, Indexed Indirect.	1	11	1111	0nkk	1nmm	Z	<b>2</b>
	n mm	Move W to Indirect FSRn with pre/post inc/dec modifier, mm	1	00	0000	0001	kkkk		<b>2, 3</b>
	k[n]	Move W to INDFn, Indexed Indirect.	1	11	1111	1nkk			<b>2</b>

**Note 1:** If the Program Counter (PC) is modified, or a conditional test is true, the instruction requires two cycles. The second cycle is executed as a NOP.

**2:** If this instruction addresses an INDF register and the MSb of the corresponding FSR is set, this instruction will require one additional instruction cycle.

**3:** See the table in the MOVIW and MOVWI instruction descriptions.



## 25.2 Instruction Descriptions

<b>ADDFSR</b>	<b>Add Literal to FSRn</b>
Syntax:	[ <i>label</i> ] ADDFSR FSRn, k
Operands:	-32 ≤ k ≤ 31 n ∈ [ 0, 1 ]
Operation:	FSR(n) + k → FSR(n)
Status Affected:	None
Description:	The signed 6-bit literal 'k' is added to the contents of the FSRnH:FSRnL register pair.  FSRn is limited to the range 0000h - FFFFh. Moving beyond these bounds will cause the FSR to wraparound.

<b>ANDLW</b>	<b>AND literal with W</b>
Syntax:	[ <i>label</i> ] ANDLW k
Operands:	0 ≤ k ≤ 255
Operation:	(W) .AND. (k) → (W)
Status Affected:	Z
Description:	The contents of W register are AND'ed with the 8-bit literal 'k'. The result is placed in the W register.

<b>ADDLW</b>	<b>Add literal and W</b>
Syntax:	[ <i>label</i> ] ADDLW k
Operands:	0 ≤ k ≤ 255
Operation:	(W) + k → (W)
Status Affected:	C, DC, Z
Description:	The contents of the W register are added to the 8-bit literal 'k' and the result is placed in the W register.

<b>ANDWF</b>	<b>AND W with f</b>
Syntax:	[ <i>label</i> ] ANDWF f,d
Operands:	0 ≤ f ≤ 127 d ∈ [0,1]
Operation:	(W) .AND. (f) → (destination)
Status Affected:	Z
Description:	AND the W register with register 'f'. If 'd' is '0', the result is stored in the W register. If 'd' is '1', the result is stored back in register 'f'.

<b>ADDWF</b>	<b>Add W and f</b>
Syntax:	[ <i>label</i> ] ADDWF f,d
Operands:	0 ≤ f ≤ 127 d ∈ [0,1]
Operation:	(W) + (f) → (destination)
Status Affected:	C, DC, Z
Description:	Add the contents of the W register with register 'f'. If 'd' is '0', the result is stored in the W register. If 'd' is '1', the result is stored back in register 'f'.

<b>ASRF</b>	<b>Arithmetic Right Shift</b>
Syntax:	[ <i>label</i> ] ASRF f {,d}
Operands:	0 ≤ f ≤ 127 d ∈ [0,1]
Operation:	(f<7>) → dest<7> (f<7:1>) → dest<6:0>, (f<0>) → C,
Status Affected:	C, Z
Description:	The contents of register 'f' are shifted one bit to the right through the Carry flag. The MSb remains unchanged. If 'd' is '0', the result is placed in W. If 'd' is '1', the result is stored back in register 'f'.

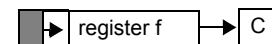

<b>ADDWFC</b>	<b>ADD W and CARRY bit to f</b>
Syntax:	[ <i>label</i> ] ADDWFC f {,d}
Operands:	0 ≤ f ≤ 127 d ∈ [0,1]
Operation:	(W) + (f) + (C) → dest
Status Affected:	C, DC, Z
Description:	Add W, the Carry flag and data memory location 'f'. If 'd' is '0', the result is placed in W. If 'd' is '1', the result is placed in data memory location 'f'.

# PIC12(L)F1571/2

---

**BCF**                    **Bit Clear f**

---

Syntax:                [ *label* ] BCF   f,b

Operands:             $0 \leq f \leq 127$   
                          $0 \leq b \leq 7$

Operation:             $0 \rightarrow (f<b>)$

Status Affected:    None

Description:         Bit 'b' in register 'f' is cleared.

**BTFSC**                **Bit Test f, Skip if Clear**

---

Syntax:                [ *label* ] BTFSC   f,b

Operands:             $0 \leq f \leq 127$   
                          $0 \leq b \leq 7$

Operation:            skip if (f<b>) = 0

Status Affected:    None

Description:         If bit 'b' in register 'f' is '1', the next instruction is executed.  
                         If bit 'b', in register 'f', is '0', the next instruction is discarded, and a NOP is executed instead, making this a 2-cycle instruction.

**BRA**                    **Relative Branch**

---

Syntax:                [ *label* ] BRA   label  
                         [ *label* ] BRA   \$+k

Operands:             $-256 \leq \text{label} - \text{PC} + 1 \leq 255$   
                          $-256 \leq k \leq 255$

Operation:             $(\text{PC}) + 1 + k \rightarrow \text{PC}$

Status Affected:    None

Description:         Add the signed 9-bit literal 'k' to the PC. Since the PC will have incremented to fetch the next instruction, the new address will be  $\text{PC} + 1 + k$ . This instruction is a 2-cycle instruction. This branch has a limited range.

**BTFSS**                **Bit Test f, Skip if Set**

---

Syntax:                [ *label* ] BTFSS   f,b

Operands:             $0 \leq f \leq 127$   
                          $0 \leq b < 7$

Operation:            skip if (f<b>) = 1

Status Affected:    None

Description:         If bit 'b' in register 'f' is '0', the next instruction is executed.  
                         If bit 'b' is '1', then the next instruction is discarded and a NOP is executed instead, making this a 2-cycle instruction.

**BRW**                    **Relative Branch with W**

---

Syntax:                [ *label* ] BRW

Operands:            None

Operation:             $(\text{PC}) + (W) \rightarrow \text{PC}$

Status Affected:    None

Description:         Add the contents of W (unsigned) to the PC. Since the PC will have incremented to fetch the next instruction, the new address will be  $\text{PC} + 1 + (W)$ . This instruction is a 2-cycle instruction.

**BSF**                    **Bit Set f**

---

Syntax:                [ *label* ] BSF   f,b

Operands:             $0 \leq f \leq 127$   
                          $0 \leq b \leq 7$

Operation:             $1 \rightarrow (f<b>)$

Status Affected:    None

Description:         Bit 'b' in register 'f' is set.

<b>CALL</b>	<b>Call Subroutine</b>
Syntax:	[ <i>label</i> ] CALL k
Operands:	$0 \leq k \leq 2047$
Operation:	(PC)+ 1 → TOS, k → PC<10:0>, (PCLATH<6:3>) → PC<14:11>
Status Affected:	None
Description:	Call Subroutine. First, return address (PC + 1) is pushed onto the stack. The 11-bit immediate address is loaded into PC bits <10:0>. The upper bits of the PC are loaded from PCLATH. CALL is a 2-cycle instruction.

<b>CLRWDT</b>	<b>Clear Watchdog Timer</b>
Syntax:	[ <i>label</i> ] CLRWDT
Operands:	None
Operation:	00h → WDT 0 → WDT prescaler, 1 → $\overline{TO}$ 1 → $\overline{PD}$
Status Affected:	$\overline{TO}$ , $\overline{PD}$
Description:	CLRWDT instruction resets the Watchdog Timer. It also resets the prescaler of the WDT. Status bits $\overline{TO}$ and $\overline{PD}$ are set.

<b>CALLW</b>	<b>Subroutine Call With W</b>
Syntax:	[ <i>label</i> ] CALLW
Operands:	None
Operation:	(PC) + 1 → TOS, (W) → PC<7:0>, (PCLATH<6:0>) → PC<14:8>
Status Affected:	None
Description:	Subroutine call with W. First, the return address (PC + 1) is pushed onto the return stack. Then, the contents of W is loaded into PC<7:0>, and the contents of PCLATH into PC<14:8>. CALLW is a 2-cycle instruction.

<b>COMF</b>	<b>Complement f</b>
Syntax:	[ <i>label</i> ] COMF f,d
Operands:	$0 \leq f \leq 127$ $d \in [0,1]$
Operation:	$\bar{f}$ → (destination)
Status Affected:	Z
Description:	The contents of register 'f' are complemented. If 'd' is '0', the result is stored in W. If 'd' is '1', the result is stored back in register 'f'.

<b>CLRF</b>	<b>Clear f</b>
Syntax:	[ <i>label</i> ] CLRF f
Operands:	$0 \leq f \leq 127$
Operation:	00h → (f) 1 → Z
Status Affected:	Z
Description:	The contents of register 'f' are cleared and the Z bit is set.

<b>DECF</b>	<b>Decrement f</b>
Syntax:	[ <i>label</i> ] DECF f,d
Operands:	$0 \leq f \leq 127$ $d \in [0,1]$
Operation:	(f) - 1 → (destination)
Status Affected:	Z
Description:	Decrement register 'f'. If 'd' is '0', the result is stored in the W register. If 'd' is '1', the result is stored back in register 'f'.

<b>CLRW</b>	<b>Clear W</b>
Syntax:	[ <i>label</i> ] CLRW
Operands:	None
Operation:	00h → (W) 1 → Z
Status Affected:	Z
Description:	W register is cleared. Zero bit (Z) is set.

# PIC12(L)F1571/2

---

---

## **DECFSZ**      **Decrement f, Skip if 0**

---

**Syntax:**      [ *label* ] DECFSZ f,d

**Operands:**       $0 \leq f \leq 127$   
                     $d \in [0,1]$

**Operation:**      (f) - 1 → (destination);  
                    skip if result = 0

**Status Affected:**      None

**Description:**      The contents of register 'f' are decremented. If 'd' is '0', the result is placed in the W register. If 'd' is '1', the result is placed back in register 'f'. If the result is '1', the next instruction is executed. If the result is '0', then a NOP is executed instead, making it a 2-cycle instruction.

## **INCFSZ**      **Increment f, Skip if 0**

---

**Syntax:**      [ *label* ] INCFSZ f,d

**Operands:**       $0 \leq f \leq 127$   
                     $d \in [0,1]$

**Operation:**      (f) + 1 → (destination),  
                    skip if result = 0

**Status Affected:**      None

**Description:**      The contents of register 'f' are incremented. If 'd' is '0', the result is placed in the W register. If 'd' is '1', the result is placed back in register 'f'. If the result is '1', the next instruction is executed. If the result is '0', a NOP is executed instead, making it a 2-cycle instruction.

## **GOTO**      **Unconditional Branch**

---

**Syntax:**      [ *label* ] GOTO k

**Operands:**       $0 \leq k \leq 2047$

**Operation:**       $k \rightarrow PC<10:0>$   
                     $PCLATH<6:3> \rightarrow PC<14:11>$

**Status Affected:**      None

**Description:**      GOTO is an unconditional branch. The 11-bit immediate value is loaded into PC bits <10:0>. The upper bits of PC are loaded from PCLATH<4:3>. GOTO is a 2-cycle instruction.

## **IORLW**      **Inclusive OR literal with W**

---

**Syntax:**      [ *label* ] IORLW k

**Operands:**       $0 \leq k \leq 255$

**Operation:**      (W) .OR. k → (W)

**Status Affected:**      Z

**Description:**      The contents of the W register are OR'ed with the 8-bit literal 'k'. The result is placed in the W register.

## **INCF**      **Increment f**

---

**Syntax:**      [ *label* ] INCF f,d

**Operands:**       $0 \leq f \leq 127$   
                     $d \in [0,1]$

**Operation:**      (f) + 1 → (destination)

**Status Affected:**      Z

**Description:**      The contents of register 'f' are incremented. If 'd' is '0', the result is placed in the W register. If 'd' is '1', the result is placed back in register 'f'.

## **IORWF**      **Inclusive OR W with f**

---

**Syntax:**      [ *label* ] IORWF f,d

**Operands:**       $0 \leq f \leq 127$   
                     $d \in [0,1]$

**Operation:**      (W) .OR. (f) → (destination)

**Status Affected:**      Z

**Description:**      Inclusive OR the W register with register 'f'. If 'd' is '0', the result is placed in the W register. If 'd' is '1', the result is placed back in register 'f'.

**LSLF**                      **Logical Left Shift**

---

Syntax:                    `[label] LSLF f{,d}`

Operands:                 $0 \leq f \leq 127$   
 $d \in [0,1]$

Operation:                 $(f<7>) \rightarrow C$   
 $(f<6:0>) \rightarrow \text{dest}<7:1>$   
 $0 \rightarrow \text{dest}<0>$

Status Affected:        C, Z

Description:              The contents of register 'f' are shifted one bit to the left through the Carry flag. A '0' is shifted into the LSb. If 'd' is '0', the result is placed in W. If 'd' is '1', the result is stored back in register 'f'.



**LSRF**                      **Logical Right Shift**

---

Syntax:                    `[label] LSRF f{,d}`

Operands:                 $0 \leq f \leq 127$   
 $d \in [0,1]$

Operation:                 $0 \rightarrow \text{dest}<7>$   
 $(f<7:1>) \rightarrow \text{dest}<6:0>$ ,  
 $(f<0>) \rightarrow C$ ,

Status Affected:        C, Z

Description:              The contents of register 'f' are shifted one bit to the right through the Carry flag. A '0' is shifted into the MSb. If 'd' is '0', the result is placed in W. If 'd' is '1', the result is stored back in register 'f'.

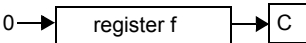

**MOVF**                      **Move f**

---

Syntax:                    `[label] MOVF f,d`

Operands:                 $0 \leq f \leq 127$   
 $d \in [0,1]$

Operation:                 $(f) \rightarrow (\text{dest})$

Status Affected:        Z

Description:              The contents of register f is moved to a destination dependent upon the status of d. If  $d = 0$ , destination is W register. If  $d = 1$ , the destination is file register f itself.  $d = 1$  is useful to test a file register since status flag Z is affected.

Words:                    1

Cycles:                    1

Example:                    `MOVF FSR, 0`

After Instruction  
W = value in FSR register  
Z = 1

# PIC12(L)F1571/2

## MOVIW Move INDFn to W

Syntax: [ *label* ] MOVIW ++FSRn  
 [ *label* ] MOVIW --FSRn  
 [ *label* ] MOVIW FSRn++  
 [ *label* ] MOVIW FSRn--  
 [ *label* ] MOVIW k[FSRn]

Operands:  $n \in [0,1]$   
 $mm \in [00,01, 10, 11]$   
 $-32 \leq k \leq 31$

Operation: INDFn  $\rightarrow$  W  
 Effective address is determined by

- FSR + 1 (preincrement)
- FSR - 1 (predecrement)
- FSR + k (relative offset)

After the Move, the FSR value will be either:

- FSR + 1 (all increments)
- FSR - 1 (all decrements)
- Unchanged

Status Affected: Z

Mode	Syntax	mm
Preincrement	++FSRn	00
Predecrement	--FSRn	01
Postincrement	FSRn++	10
Postdecrement	FSRn--	11

Description: This instruction is used to move data between W and one of the indirect registers (INDFn). Before/after this move, the pointer (FSRn) is updated by pre/post incrementing/decrementing it.

**Note:** The INDFn registers are not physical registers. Any instruction that accesses an INDFn register actually accesses the register at the address specified by the FSRn.

FSRn is limited to the range 0000h - FFFFh. Incrementing/decrementing it beyond these bounds will cause it to wraparound.

## MOVLB Move literal to BSR

Syntax: [ *label* ] MOVLB k

Operands:  $0 \leq k \leq 31$

Operation:  $k \rightarrow$  BSR

Status Affected: None

Description: The 5-bit literal 'k' is loaded into the Bank Select Register (BSR).

## MOVLPL Move literal to PCLATH

Syntax: [ *label* ] MOVLPL k

Operands:  $0 \leq k \leq 127$

Operation:  $k \rightarrow$  PCLATH

Status Affected: None

Description: The 7-bit literal 'k' is loaded into the PCLATH register.

## MOVLW Move literal to W

Syntax: [ *label* ] MOVLW k

Operands:  $0 \leq k \leq 255$

Operation:  $k \rightarrow$  (W)

Status Affected: None

Description: The 8-bit literal 'k' is loaded into W register. The "don't cares" will assemble as '0's.

Words: 1

Cycles: 1

Example: MOVLW 0x5A  
 After Instruction  
 W = 0x5A

## MOVWF Move W to f

Syntax: [ *label* ] MOVWF f

Operands:  $0 \leq f \leq 127$

Operation: (W)  $\rightarrow$  (f)

Status Affected: None

Description: Move data from W register to register 'f'.

Words: 1

Cycles: 1

Example: MOVWF OPTION\_REG  
 Before Instruction  
 OPTION\_REG = 0xFF  
 W = 0x4F  
 After Instruction  
 OPTION\_REG = 0x4F  
 W = 0x4F

**MOVWI**                      **Move W to INDFn**

---

Syntax:                      [ *label* ] MOVWI ++FSRn  
                                  [ *label* ] MOVWI --FSRn  
                                  [ *label* ] MOVWI FSRn++  
                                  [ *label* ] MOVWI FSRn--  
                                  [ *label* ] MOVWI k[FSRn]

Operands:                   n ∈ [0,1]  
                                  mm ∈ [00,01, 10, 11]  
                                  -32 ≤ k ≤ 31

Operation:                   W → INDFn  
                                  Effective address is determined by

- FSR + 1 (preincrement)
- FSR - 1 (predecrement)
- FSR + k (relative offset)

After the Move, the FSR value will be either:

- FSR + 1 (all increments)
- FSR - 1 (all decrements)

Unchanged

Status Affected:           None

Mode	Syntax	mm
Preincrement	++FSRn	00
Predecrement	--FSRn	01
Postincrement	FSRn++	10
Postdecrement	FSRn--	11

Description:                   This instruction is used to move data between W and one of the indirect registers (INDFn). Before/after this move, the pointer (FSRn) is updated by pre/post incrementing/decrementing it.

**Note:** The INDFn registers are not physical registers. Any instruction that accesses an INDFn register actually accesses the register at the address specified by the FSRn.

FSRn is limited to the range 0000h - FFFFh. Incrementing/decrementing it beyond these bounds will cause it to wraparound.

The increment/decrement operation on FSRn WILL NOT affect any Status bits.

**NOP**                              **No Operation**

---

Syntax:                      [ *label* ] NOP

Operands:                      None

Operation:                      No operation

Status Affected:              None

Description:                      No operation.

Words:                              1

Cycles:                              1

Example:                              NOP

**OPTION**                              **Load OPTION\_REG Register with W**

---

Syntax:                      [ *label* ] OPTION

Operands:                      None

Operation:                      (W) → OPTION\_REG

Status Affected:              None

Description:                      Move data from W register to OPTION\_REG register.

**RESET**                              **Software Reset**

---

Syntax:                      [ *label* ] RESET

Operands:                      None

Operation:                      Execute a device Reset. Resets the nRI flag of the PCON register.

Status Affected:              None

Description:                      This instruction provides a way to execute a hardware Reset by software.

# PIC12(L)F1571/2

**RETFIE**      **Return from Interrupt**

---

Syntax:      [ *label* ] RETFIE

Operands:    None

Operation:    TOS → PC,  
                  1 → GIE

Status Affected:    None

Description:    Return from Interrupt. Stack is POPed and Top-of-Stack (TOS) is loaded in the PC. Interrupts are enabled by setting Global Interrupt Enable bit, GIE (INTCON<7>). This is a 2-cycle instruction.

Words:        1

Cycles:        2

Example:      RETFIE

                  After Interrupt

                  PC = TOS

                  GIE = 1

**RETURN**      **Return from Subroutine**

---

Syntax:      [ *label* ] RETURN

Operands:    None

Operation:    TOS → PC

Status Affected:    None

Description:    Return from subroutine. The stack is POPed and the top of the stack (TOS) is loaded into the Program Counter. This is a 2-cycle instruction.

**RETLW**      **Return with literal in W**

---

Syntax:      [ *label* ] RETLW *k*

Operands:     $0 \leq k \leq 255$

Operation:    *k* → (W);  
                  TOS → PC

Status Affected:    None

Description:    The W register is loaded with the 8-bit literal '*k*'. The Program Counter is loaded from the top of the stack (the return address). This is a 2-cycle instruction.

Words:        1

Cycles:        2

Example:      CALL TABLE;W contains table  
                                  ;offset value

                  •    ;W now has table value

                  •

                  •

                  ADDWF PC ;W = offset

                  RETLW *k1* ;Begin table

                  RETLW *k2* ;

                  •

                  •

                  •

                  RETLW *kn* ; End of table

                  Before Instruction

                  W = 0x07

                  After Instruction

                  W = value of *k8*

**RLF**          **Rotate Left f through Carry**

---

Syntax:      [ *label* ] RLF *f,d*

Operands:     $0 \leq f \leq 127$   
                   $d \in \{0,1\}$

Operation:    See description below

Status Affected:    C

Description:    The contents of register '*f*' are rotated one bit to the left through the Carry flag. If '*d*' is '0', the result is placed in the W register. If '*d*' is '1', the result is stored back in register '*f*'.

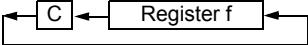

Words:        1

Cycles:        1

Example:      RLF      REG1,0

                  Before Instruction

                  REG1    = 1110 0110

                  C        = 0

                  After Instruction

                  REG1    = 1110 0110

                  W        = 1100 1100

                  C        = 1



**RRF**                      **Rotate Right f through Carry**

---

Syntax:                    [ *label* ] RRF f,d

Operands:                 $0 \leq f \leq 127$   
 $d \in [0,1]$

Operation:                See description below

Status Affected:        C

Description:              The contents of register 'f' are rotated one bit to the right through the Carry flag. If 'd' is '0', the result is placed in the W register. If 'd' is '1', the result is placed back in register 'f'.

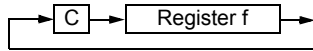

**SUBLW**                    **Subtract W from literal**

---

Syntax:                    [ *label* ] SUBLW k

Operands:                 $0 \leq k \leq 255$

Operation:                 $k - (W) \rightarrow (W)$

Status Affected:        C, DC, Z

Description:              The W register is subtracted (2's complement method) from the 8-bit literal 'k'. The result is placed in the W register.

C = 0	$W > k$
C = 1	$W \leq k$
DC = 0	$W\langle 3:0 \rangle > k\langle 3:0 \rangle$
DC = 1	$W\langle 3:0 \rangle \leq k\langle 3:0 \rangle$

**SLEEP**                    **Enter Sleep mode**

---

Syntax:                    [ *label* ] SLEEP

Operands:                None

Operation:                00h → WDT,  
0 → WDT prescaler,  
1 →  $\overline{TO}$ ,  
0 →  $\overline{PD}$

Status Affected:         $\overline{TO}$ ,  $\overline{PD}$

Description:              The power-down Status bit,  $\overline{PD}$  is cleared. Time-out Status bit,  $\overline{TO}$  is set. Watchdog Timer and its prescaler are cleared.  
The processor is put into Sleep mode with the oscillator stopped.

**SUBWF**                    **Subtract W from f**

---

Syntax:                    [ *label* ] SUBWF f,d

Operands:                 $0 \leq f \leq 127$   
 $d \in [0,1]$

Operation:                 $(f) - (W) \rightarrow (\text{destination})$

Status Affected:        C, DC, Z

Description:              Subtract (2's complement method) W register from register 'f'. If 'd' is '0', the result is stored in the W register. If 'd' is '1', the result is stored back in register 'f'.

C = 0	$W > f$
C = 1	$W \leq f$
DC = 0	$W\langle 3:0 \rangle > f\langle 3:0 \rangle$
DC = 1	$W\langle 3:0 \rangle \leq f\langle 3:0 \rangle$

**SUBWFB**                   **Subtract W from f with Borrow**

---

Syntax:                    SUBWFB f {,d}

Operands:                 $0 \leq f \leq 127$   
 $d \in [0,1]$

Operation:                 $(f) - (W) - (\overline{B}) \rightarrow \text{dest}$

Status Affected:        C, DC, Z

Description:              Subtract W and the BORROW flag (CARRY) from register 'f' (2's complement method). If 'd' is '0', the result is stored in W. If 'd' is '1', the result is stored back in register 'f'.

# PIC12(L)F1571/2

---

## **SWAPF**      **Swap Nibbles in f**

---

Syntax:      [ *label* ] SWAPF f,d

Operands:     $0 \leq f \leq 127$   
               $d \in [0,1]$

Operation:    ( $f<3:0>$ )  $\rightarrow$  (destination<7:4>),  
              ( $f<7:4>$ )  $\rightarrow$  (destination<3:0>)

Status Affected:    None

Description:    The upper and lower nibbles of register 'f' are exchanged. If 'd' is '0', the result is placed in the W register. If 'd' is '1', the result is placed in register 'f'.

## **XORLW**      **Exclusive OR literal with W**

---

Syntax:      [ *label* ] XORLW k

Operands:     $0 \leq k \leq 255$

Operation:    (W) .XOR. k  $\rightarrow$  (W)

Status Affected:    Z

Description:    The contents of the W register are XOR'ed with the 8-bit literal 'k'. The result is placed in the W register.

## **TRIS**      **Load TRIS Register with W**

---

Syntax:      [ *label* ] TRIS f

Operands:     $5 \leq f \leq 7$

Operation:    (W)  $\rightarrow$  TRIS register 'f'

Status Affected:    None

Description:    Move data from W register to TRIS register.  
              When 'f' = 5, TRISA is loaded.  
              When 'f' = 6, TRISB is loaded.  
              When 'f' = 7, TRISC is loaded.

## **XORWF**      **Exclusive OR W with f**

---

Syntax:      [ *label* ] XORWF f,d

Operands:     $0 \leq f \leq 127$   
               $d \in [0,1]$

Operation:    (W) .XOR. (f)  $\rightarrow$  (destination)

Status Affected:    Z

Description:    Exclusive OR the contents of the W register with register 'f'. If 'd' is '0', the result is stored in the W register. If 'd' is '1', the result is stored back in register 'f'.

## 26.0 ELECTRICAL SPECIFICATIONS

### 26.1 Absolute Maximum Ratings<sup>(†)</sup>

Ambient temperature under bias .....	-40°C to +125°C
Storage temperature .....	-65°C to +150°C
Voltage on pins with respect to V <sub>SS</sub> :	
on V <sub>DD</sub> pin	
PIC12F1571/2 .....	-0.3V to +6.5V
PIC12LF1571/2 .....	-0.3V to +4.0V
on MCLR pin .....	-0.3V to +9.0V
on all other pins .....	-0.3V to (V <sub>DD</sub> + 0.3V)
Maximum current:	
on V <sub>SS</sub> pin <sup>(1)</sup>	
-40°C ≤ T <sub>A</sub> ≤ +85°C .....	250 mA
+85°C ≤ T <sub>A</sub> ≤ +125°C .....	85 mA
on V <sub>DD</sub> pin <sup>(1)</sup>	
-40°C ≤ T <sub>A</sub> ≤ +85°C .....	250 mA
+85°C ≤ T <sub>A</sub> ≤ +125°C .....	85 mA
Sunk by any standard I/O pin .....	50 mA
Sourced by any standard I/O pin .....	50 mA
Clamp current, I <sub>K</sub> (V <sub>PI</sub> N < 0 or V <sub>PI</sub> N > V <sub>DD</sub> ) .....	±20 mA
Total power dissipation <sup>(2)</sup> .....	800 mW

**Note 1:** Maximum current rating requires even load distribution across I/O pins. Maximum current rating may be limited by the device package power dissipation characterizations, see [Table 26-6](#): “Thermal Characteristics” to calculate device specifications.

**2:** Power dissipation is calculated as follows:  $P_{DIS} = V_{DD} \times \{I_{DD} - \sum I_{OH}\} + \sum \{(V_{DD} - V_{OH}) \times I_{OH}\} + \sum (V_{OL} \times I_{OL})$ .

† NOTICE: Stresses above those listed under “Absolute Maximum Ratings” may cause permanent damage to the device. This is a stress rating only and functional operation of the device at those or any other conditions above those indicated in the operation listings of this specification is not implied. Exposure above maximum rating conditions for extended periods may affect device reliability.

# PIC12(L)F1571/2

---

## 26.2 Standard Operating Conditions

The standard operating conditions for any device are defined as:

Operating Voltage:  $V_{DDMIN} \leq V_{DD} \leq V_{DDMAX}$

Operating Temperature:  $T_{A\_MIN} \leq T_A \leq T_{A\_MAX}$

### V<sub>DD</sub> — Operating Supply Voltage<sup>(1)</sup>

#### PIC12LF1571/2

V <sub>DDMIN</sub> (F <sub>OSC</sub> ≤ 16 MHz).....	+1.8V
V <sub>DDMIN</sub> (F <sub>OSC</sub> ≤ 32 MHz).....	+2.5V
V <sub>DDMAX</sub> .....	+3.6V

#### PIC12F1571/2

V <sub>DDMIN</sub> (F <sub>OSC</sub> ≤ 16 MHz).....	+2.3V
V <sub>DDMIN</sub> (F <sub>OSC</sub> ≤ 32 MHz).....	+2.5V
V <sub>DDMAX</sub> .....	+5.5V

### T<sub>A</sub> — Operating Ambient Temperature Range

#### Industrial Temperature

T <sub>A\_MIN</sub> .....	-40°C
T <sub>A\_MAX</sub> .....	+85°C

#### Extended Temperature

T <sub>A\_MIN</sub> .....	-40°C
T <sub>A\_MAX</sub> .....	+125°C

**Note 1:** See Parameter [D001](#), DS Characteristics: Supply Voltage.

**FIGURE 26-1: VOLTAGE FREQUENCY GRAPH,  $-40^{\circ}\text{C} \leq T_A \leq +125^{\circ}\text{C}$ , PIC12F1571/2 ONLY**

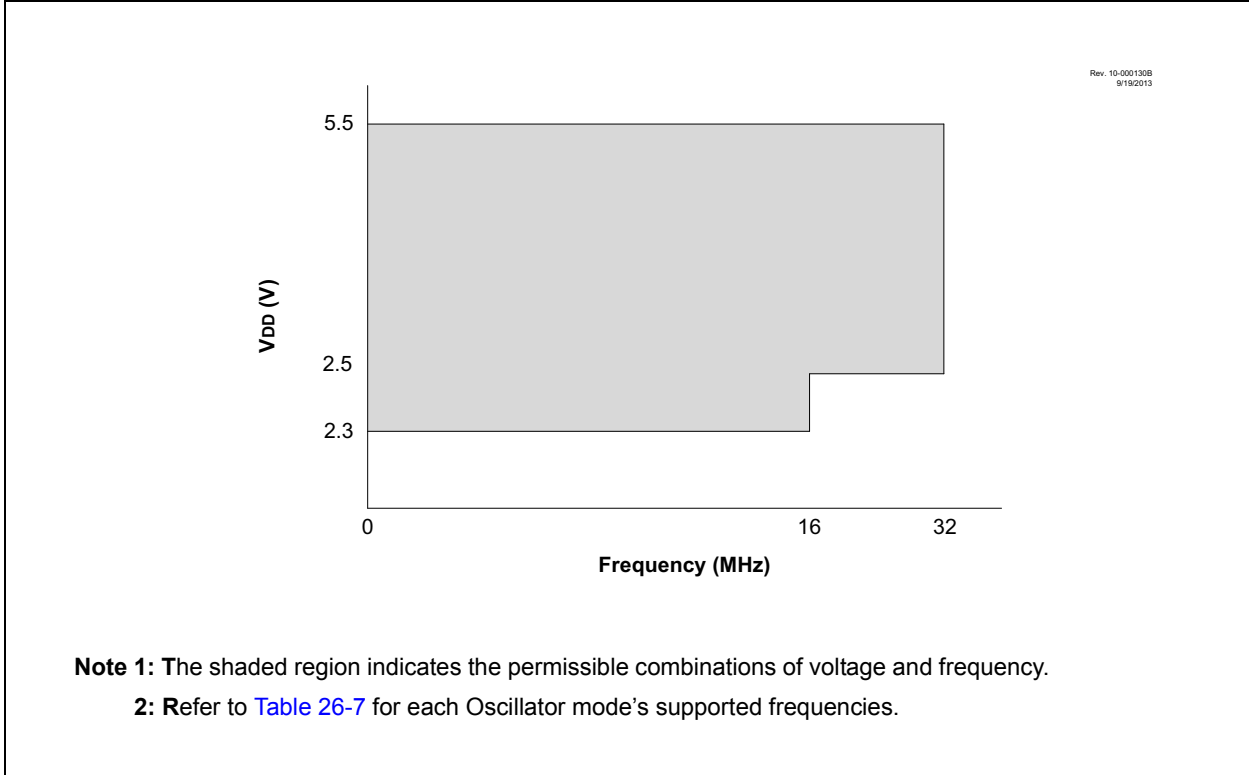

**FIGURE 26-2: VOLTAGE FREQUENCY GRAPH,  $-40^{\circ}\text{C} \leq T_A \leq +125^{\circ}\text{C}$ , PIC12LF1571/2 ONLY**

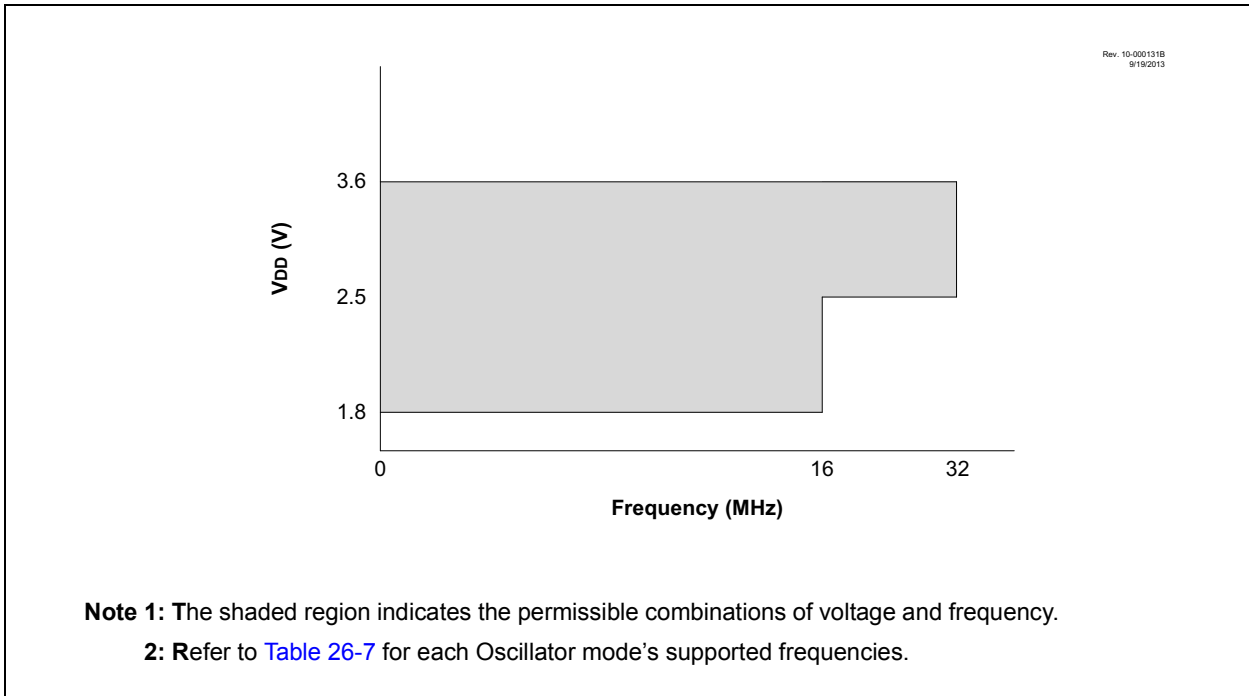

# PIC12(L)F1571/2

## 26.3 DC Characteristics

**TABLE 26-1: SUPPLY VOLTAGE**

PIC12LF1571/2		Standard Operating Conditions (unless otherwise stated)					
PIC12F1571/2							
Param. No.	Sym.	Characteristic	Min.	Typ†	Max.	Units	Conditions
D001	VDD	<b>Supply Voltage</b>					
			VDDMIN 1.8 2.5	— —	VDDMAX 3.6 3.6	V V	FOSC ≤ 16 MHz FOSC ≤ 32 MHz ( <b>Note 3</b> )
D001			2.3 2.5	— —	5.5 5.5	V V	FOSC ≤ 16 MHz FOSC ≤ 32 MHz ( <b>Note 3</b> )
D002*	VDR	<b>RAM Data Retention Voltage<sup>(1)</sup></b>					
			1.5	—	—	V	Device in Sleep mode
D002*			1.7	—	—	V	Device in Sleep mode
D002A*	VPOR	<b>Power-on Reset Release Voltage<sup>(2)</sup></b>					
			—	1.6	—	V	
D002A*			—	1.6	—	V	
D002B*	VPORR*	<b>Power-on Reset Rearm Voltage<sup>(2)</sup></b>					
			—	0.8	—	V	
D002B*			—	1.5	—	V	
D003	VFVR	<b>Fixed Voltage Reference Voltage</b>	—	1.024	—	V	-40°C ≤ TA ≤ +85°C
D003A	VADFVR	<b>FVR Gain Voltage Accuracy for ADC</b>	-4	—	+4	%	1x VFVR, ADFVR = 01, VDD ≥ 2.5V 2x VFVR, ADFVR = 10, VDD ≥ 2.5V 4x VFVR, ADFVR = 11, VDD ≥ 4.75V
D003B	VCDAFVR	<b>FVR Gain Voltage Accuracy for Comparator</b>	-4	—	+4	%	1x VFVR, CDAFVR = 01, VDD ≥ 2.5V 2x VFVR, CDAFVR = 10, VDD ≥ 2.5V 4x VFVR, CDAFVR = 11, VDD ≥ 4.75V
D004*	SVDD	<b>VDD Rise Rate<sup>(2)</sup></b>	0.05	—	—	V/ms	Ensures that the Power-on Reset signal is released properly

\* These parameters are characterized but not tested.

† Data in "Typ" column is at 3.0V, +25°C unless otherwise stated. These parameters are for design guidance only and are not tested.

**Note 1:** This is the limit to which VDD can be lowered in Sleep mode without losing RAM data.

**2:** See [Figure 26-3](#), POR and POR Rearm with Slow Rising VDD.

**3:** PLL required for 32 MHz operation.

FIGURE 26-3: POR AND POR REARM WITH SLOW RISING V<sub>DD</sub>

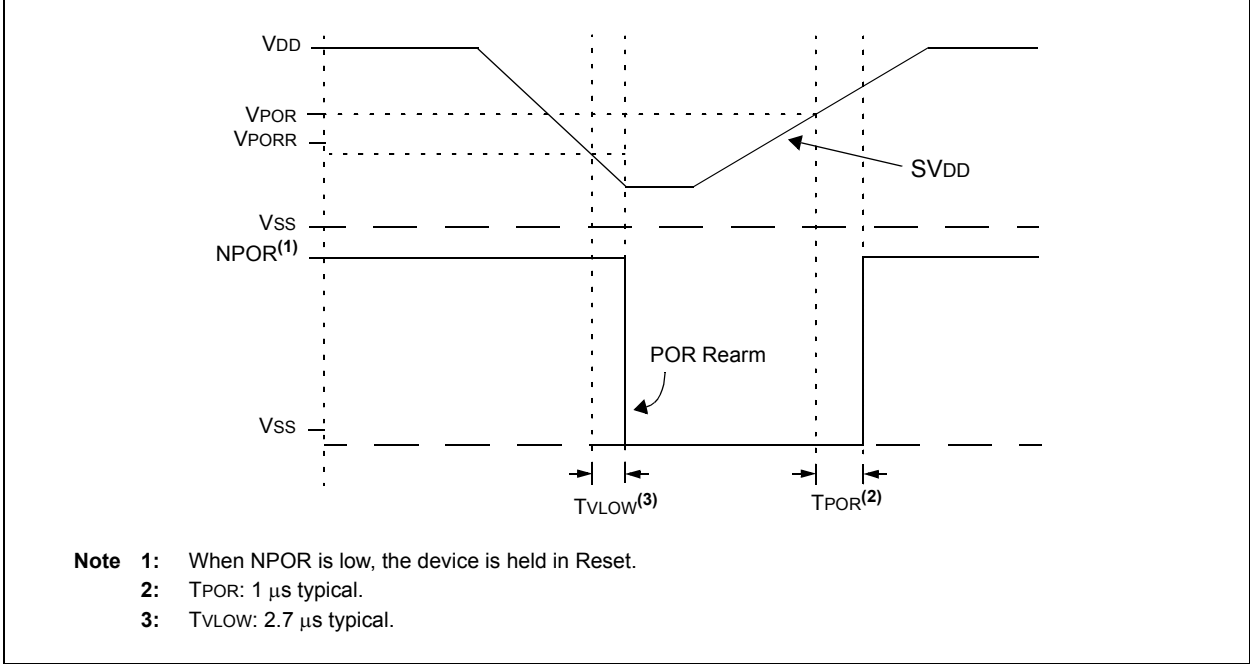

# PIC12(L)F1571/2

**TABLE 26-2: SUPPLY CURRENT (IDD)<sup>(1,2)</sup>**

PIC12LF1571/2		Standard Operating Conditions (unless otherwise stated)					
PIC12F1571/2							
Param. No.	Device Characteristics	Min.	Typ†	Max.	Units	Conditions	
						VDD	Note
D013		—	35	44	μA	1.8	Fosc = 1 MHz, External Clock (ECM), Medium Power mode
		—	60	69	μA	3.0	
D013		—	68	93	μA	2.3	Fosc = 1 MHz, External Clock (ECM), Medium Power mode
		—	91	120	μA	3.0	
		—	131	160	μA	5.0	
D014		—	116	132	μA	1.8	Fosc = 4 MHz, External Clock (ECM), Medium Power mode
		—	203	233	μA	3.0	
D014		—	174	221	μA	2.3	Fosc = 4 MHz, External Clock (ECM), Medium Power mode
		—	234	286	μA	3.0	
		—	299	374	μA	5.0	
D015		—	5.5	11	μA	1.8	Fosc = 31 kHz, LFINTOSC, -40°C ≤ Ta ≤ +85°C
		—	7.3	12	μA	3.0	
D015		—	13	21	μA	2.3	Fosc = 31 kHz, LFINTOSC, -40°C ≤ Ta ≤ +85°C
		—	15	24	μA	3.0	
		—	17	25	μA	5.0	
D016		—	111	151	μA	1.8	Fosc = 500 kHz, MFINTOSC
		—	133	176	μA	3.0	
D016		—	144	209	μA	2.3	Fosc = 500 kHz, MFINTOSC
		—	162	237	μA	3.0	
		—	216	288	μA	5.0	
D017*		—	0.5	0.6	mA	1.8	Fosc = 8 MHz, HFINTOSC
		—	0.7	0.9	mA	3.0	
D017*		—	0.6	0.8	mA	2.3	Fosc = 8 MHz, HFINTOSC
		—	0.8	0.9	mA	3.0	
		—	0.9	1.0	mA	5.0	
D018		—	0.7	0.8	mA	1.8	Fosc = 16 MHz, HFINTOSC
		—	1.1	1.2	mA	3.0	
D018		—	0.9	1.1	mA	2.3	Fosc = 16 MHz, HFINTOSC
		—	1.1	1.3	mA	3.0	
		—	1.3	1.5	mA	5.0	

\* These parameters are characterized but not tested.

† Data in "Typ" column is at 3.0V, +25°C unless otherwise stated. These parameters are for design guidance only and are not tested.

- Note 1:** The test conditions for all IDD measurements in active operation mode are: CLKIN = external square wave, from rail-to-rail; all I/O pins tri-stated, pulled to VSS; MCLR = VDD; WDT disabled.
- 2:** The supply current is mainly a function of the operating voltage and frequency. Other factors, such as I/O pin loading and switching rate, oscillator type, internal code execution pattern and temperature, also have an impact on the current consumption.
- 3:** PLL required for 32 MHz operation.



**TABLE 26-2: SUPPLY CURRENT (IDD)<sup>(1,2)</sup> (CONTINUED)**

PIC12LF1571/2		Standard Operating Conditions (unless otherwise stated)					
PIC12F1571/2							
Param. No.	Device Characteristics	Min.	Typ†	Max.	Units	Conditions	
						VDD	Note
D018A*		—	2	2.4	mA	3.0	Fosc = 32 MHz, HFINTOSC ( <b>Note 3</b> )
D018A*		—	2.1	2.5	mA	3.0	Fosc = 32 MHz, HFINTOSC ( <b>Note 3</b> )
		—	2.2	2.6	mA	5.0	
D019A		—	1.7	1.9	mA	3.0	Fosc = 32 MHz, External Clock (ECH), High-Power mode ( <b>Note 3</b> )
D019A		—	1.8	2	mA	3.0	Fosc = 32 MHz, External Clock (ECH), High-Power mode ( <b>Note 3</b> )
		—	1.9	2.3	mA	5.0	
D019B		—	2.2	5.9	μA	1.8	Fosc = 32 kHz, External Clock (ECL), Low-Power mode
		—	4.3	8.3	μA	3.0	
D019B		—	12	20	μA	2.3	Fosc = 32 kHz, External Clock (ECL), Low-Power mode
		—	15	25	μA	3.0	
		—	17	26	μA	5.0	
D019C		—	18	25	μA	1.8	Fosc = 500 kHz, External Clock (ECL), Low-Power mode
		—	30	38	μA	3.0	
D019C		—	29	40	μA	2.3	Fosc = 500 kHz, External Clock (ECL), Low-Power mode
		—	37	51	μA	3.0	
		—	42	53	μA	5.0	

\* These parameters are characterized but not tested.

† Data in “Typ” column is at 3.0V, +25°C unless otherwise stated. These parameters are for design guidance only and are not tested.

- Note 1:** The test conditions for all IDD measurements in active operation mode are: CLKIN = external square wave, from rail-to-rail; all I/O pins tri-stated, pulled to VSS; MCLR = VDD; WDT disabled.
- 2:** The supply current is mainly a function of the operating voltage and frequency. Other factors, such as I/O pin loading and switching rate, oscillator type, internal code execution pattern and temperature, also have an impact on the current consumption.
- 3:** PLL required for 32 MHz operation.

# PIC12(L)F1571/2

**TABLE 26-3: POWER-DOWN CURRENTS (IPD)<sup>(1,2)</sup>**

PIC12LF1571/2		Operating Conditions (unless otherwise stated) Low-Power Sleep Mode						
PIC12F1571/2		Low-Power Sleep Mode, VREGPM = 1						
Param. No.	Device Characteristics	Min.	Typ†	Max. +85°C	Max. +125°C	Units	Conditions	
							VDD	Note
D022	Base IPD	—	0.020	0.6	2.6	μA	1.8	WDT, BOR and FVR disabled, all peripherals inactive, VREGPM = 1
		—	0.025	0.8	2.9	μA	3.0	
D022	Base IPD	—	0.2	0.9	2.8	μA	2.3	WDT, BOR and FVR disabled, all peripherals inactive, Low-Power Sleep mode, VREGPM = 1
		—	0.3	3.0	3.8	μA	3.0	
		—	0.4	3.6	4.5	μA	5.0	
D022A	Base IPD	—	9	14	15	μA	2.3	WDT, BOR and FVR disabled, all peripherals inactive, Normal Power Sleep mode, VREGPM = 0
		—	11	19	21	μA	3.0	
		—	12	21	22	μA	5.0	
D023		—	0.3	0.8	2.9	μA	1.8	WDT Current
		—	0.5	1.1	3.5	μA	3.0	
D023		—	0.5	1.7	4.1	μA	2.3	WDT Current
		—	0.6	1.9	4.4	μA	3.0	
		—	0.7	2.1	4.7	μA	5.0	
D023A		—	13	18	20	μA	1.8	FVR Current
		—	22	28	29	μA	3.0	
D023A		—	16	24	25	μA	2.3	FVR Current
		—	19	30	31	μA	3.0	
		—	20	33	35	μA	5.0	
D024		—	6.5	9	11	μA	3.0	BOR Current
D024		—	7.0	10	11	μA	3.0	BOR Current
		—	8.0	12	13	μA	5.0	
D24A		—	0.2	2	4	μA	3.0	LPBOR Current
D24A		—	0.4	2	4	μA	3.0	LPBOR Current
		—	0.5	3	5	μA	5.0	
D026		—	0.03	0.7	2.7	μA	1.8	ADC Current ( <b>Note 3</b> ), No conversion in progress
		—	0.04	0.8	3	μA	3.0	
D026		—	0.2	1.3	3.8	μA	2.3	ADC Current ( <b>Note 3</b> ), No conversion in progress
		—	0.3	1.4	3.9	μA	3.0	
		—	0.4	1.5	4	μA	5.0	
D026A*		—	250	—	—	μA	1.8	ADC Current ( <b>Note 3</b> ), Conversion in progress
		—	250	—	—	μA	3.0	
D026A*		—	280	—	—	μA	2.3	ADC Current ( <b>Note 3</b> ), Conversion in progress
		—	280	—	—	μA	3.0	
		—	280	—	—	μA	5.0	

\* These parameters are characterized but not tested.

† Data in "Typ" column is at 3.0V, +25°C unless otherwise stated. These parameters are for design guidance only and are not tested.

- Note 1:** The peripheral Δ current can be determined by subtracting the base IPD current from this limit. Max. values should be used when calculating total current consumption.
- Note 2:** The power-down current in Sleep mode does not depend on the oscillator type. Power-down current is measured with the part in Sleep mode, with all I/O pins in high-impedance state and tied to Vss.
- Note 3:** ADC clock source is FRC.

**TABLE 26-3: POWER-DOWN CURRENTS (I<sub>PD</sub>)<sup>(1,2)</sup> (CONTINUED)**

PIC12LF1571/2		Operating Conditions (unless otherwise stated) Low-Power Sleep Mode						
PIC12F1571/2		Low-Power Sleep Mode, VREGPM = 1						
Param. No.	Device Characteristics	Min.	Typ†	Max. +85°C	Max. +125°C	Units	Conditions	
							VDD	Note
D027		—	4	7	9	μA	1.8	Comparator, CxSP = 0
		—	4.2	8	10	μA	3.0	
D027		—	13	20	21	μA	2.3	Comparator, CxSP = 0
		—	14	23	25	μA	3.0	
		—	16	24	26	μA	5.0	
D028A		—	20	35	36	μA	1.8	Comparator, Normal Power, CxSP = 1 <b>(Note 1)</b>
		—	21	36	38	μA	3.0	
D028A		—	28	47	48	μA	2.3	Comparator, Normal Power, CxSP = 1, VREGPM = 1 <b>(Note 1)</b>
		—	29	51	52	μA	3.0	
		—	31	52	53	μA	5.0	

\* These parameters are characterized but not tested.

† Data in "Typ" column is at 3.0V, +25°C unless otherwise stated. These parameters are for design guidance only and are not tested.

- Note 1:** The peripheral Δ current can be determined by subtracting the base I<sub>PD</sub> current from this limit. Max. values should be used when calculating total current consumption.
- Note 2:** The power-down current in Sleep mode does not depend on the oscillator type. Power-down current is measured with the part in Sleep mode, with all I/O pins in high-impedance state and tied to V<sub>SS</sub>.
- Note 3:** ADC clock source is FRC.

# PIC12(L)F1571/2

**TABLE 26-4: I/O PORTS**

Standard Operating Conditions (unless otherwise stated)							
Param. No.	Sym.	Characteristic	Min.	Typ†	Max.	Units	Conditions
D030 D030A D031 D032	V <sub>IL</sub>	<b>Input Low Voltage</b>					
		I/O Ports:					
		with TTL Buffer	—	—	0.8	V	4.5V ≤ V <sub>DD</sub> ≤ 5.5V
		with Schmitt Trigger Buffer	—	—	0.15 V <sub>DD</sub>	V	1.8V ≤ V <sub>DD</sub> ≤ 4.5V
		with I <sup>2</sup> C Levels	—	—	0.2 V <sub>DD</sub>	V	2.0V ≤ V <sub>DD</sub> ≤ 5.5V
		with SMBus Levels	—	—	0.3 V <sub>DD</sub>	V	
		MCLR	—	—	0.8	V	2.7V ≤ V <sub>DD</sub> ≤ 5.5V
D040 D040A D041 D042	V <sub>IH</sub>	<b>Input High Voltage</b>					
		I/O Ports:					
		with TTL Buffer	2.0	—	—	V	4.5V ≤ V <sub>DD</sub> ≤ 5.5V
		with Schmitt Trigger Buffer	0.25 V <sub>DD</sub> + 0.8	—	—	V	1.8V ≤ V <sub>DD</sub> ≤ 4.5V
		with I <sup>2</sup> C Levels	0.8 V <sub>DD</sub>	—	—	V	2.0V ≤ V <sub>DD</sub> ≤ 5.5V
		with SMBus Levels	0.7 V <sub>DD</sub>	—	—	V	
		MCLR	2.1	—	—	V	2.7V ≤ V <sub>DD</sub> ≤ 5.5V
			0.8 V <sub>DD</sub>	—	—	V	
D060 D061	I <sub>IL</sub>	<b>Input Leakage Current<sup>(1)</sup></b>					
		I/O Ports	—	± 5	± 125	nA	V <sub>SS</sub> ≤ V <sub>PIN</sub> ≤ V <sub>DD</sub> , Pin at high-impedance, +85°C
			—	± 5	± 1000	nA	V <sub>SS</sub> ≤ V <sub>PIN</sub> ≤ V <sub>DD</sub> , Pin at high-impedance, +125°C
		MCLR <sup>(2)</sup>	—	± 50	± 200	nA	V <sub>SS</sub> ≤ V <sub>PIN</sub> ≤ V <sub>DD</sub> , Pin at high-impedance, +85°C
D070*	I <sub>PUR</sub>	<b>Weak Pull-up Current</b>					
			25	100	200	μA	V <sub>DD</sub> = 3.3V, V <sub>PIN</sub> = V <sub>SS</sub>
			25	140	300	μA	V <sub>DD</sub> = 5.0V, V <sub>PIN</sub> = V <sub>SS</sub>
D080	V <sub>OL</sub>	<b>Output Low Voltage</b>					
		I/O Ports	—	—	0.6	V	I <sub>OL</sub> = 8 mA, V <sub>DD</sub> = 5V I <sub>OL</sub> = 6 mA, V <sub>DD</sub> = 3.3V I <sub>OL</sub> = 1.8 mA, V <sub>DD</sub> = 1.8V
D090	V <sub>OH</sub>	<b>Output High Voltage</b>					
		I/O Ports	V <sub>DD</sub> - 0.7	—	—	V	I <sub>OH</sub> = 3.5 mA, V <sub>DD</sub> = 5V I <sub>OH</sub> = 3 mA, V <sub>DD</sub> = 3.3V I <sub>OH</sub> = 1 mA, V <sub>DD</sub> = 1.8V
D101A*	C <sub>IO</sub>	<b>Capacitive Loading Specifications on Output Pins</b>					
		All I/O Pins	—	—	50	pF	

\* These parameters are characterized but not tested.

† Data in "Typ" column is at 3.0V, +25°C unless otherwise stated. These parameters are for design guidance only and are not tested.

**Note 1:** Negative current is defined as current sourced by the pin.

**Note 2:** The leakage current on the MCLR pin is strongly dependent on the applied voltage level. The specified levels represent normal operating conditions. Higher leakage current may be measured at different input voltages.

**TABLE 26-5: MEMORY PROGRAMMING SPECIFICATIONS**

Standard Operating Conditions (unless otherwise stated)							
Param. No.	Sym.	Characteristic	Min.	Typ†	Max.	Units	Conditions
		<b>Program Memory Programming Specifications</b>					
D110	VIHH	Voltage on $\overline{\text{MCLR}}/\text{VPP}$ Pin	8.0	—	9.0	V	<b>(Note 2)</b>
D111	IDDP	Supply Current during Programming	—	—	10	mA	
D112	VBE	VDD for Bulk Erase	2.7	—	VDDMAX	V	
D113	VPEW	VDD for Write or Row Erase	VDDMIN	—	VDDMAX	V	
D114	IPPPGM	Current on $\overline{\text{MCLR}}/\text{VPP}$ during Erase/Write	—	1.0	—	mA	
D115	IDDPGM	Current on VDD during Erase/Write	—	5.0	—	mA	
		<b>Program Flash Memory</b>					
D121	EP	Cell Endurance	10K	—	—	E/W	-40°C ≤ TA ≤ +85°C <b>(Note 1)</b>
D122	VPRW	VDD for Read/Write	VDDMIN	—	VDDMAX	V	
D123	TIW	Self-Timed Write Cycle Time	—	2	2.5	ms	Provided no other specifications are violated
D124	TRETD	Characteristic Retention	—	40	—	Year	
D125	EHEFC	High-Endurance Flash Cell	100K	—	—	E/W	0°C ≤ TA ≤ +60°C, lower byte last 128 addresses

† Data in “Typ” column is at 3.0V, +25°C unless otherwise stated. These parameters are for design guidance only and are not tested.

**Note 1:** Self-write and block erase.

**2:** Required only if single-supply programming is disabled.

# PIC12(L)F1571/2

**TABLE 26-6: THERMAL CHARACTERISTICS**

Standard Operating Conditions (unless otherwise stated)					
Param. No.	Sym.	Characteristic	Typ.	Units	Conditions
TH01	θJA	Thermal Resistance Junction to Ambient	56.7	°C/W	8-pin DFN 3x3 mm package
			89.3	°C/W	8-pin PDIP package
			149.5	°C/W	8-pin SOIC package
			39.4	°C/W	8-pin UDFN 3x3 mm package
TH02	θJC	Thermal Resistance Junction to Case	9.0	°C/W	8-pin DFN 3x3 mm package
			43.1	°C/W	8-pin PDIP package
			39.9	°C/W	8-pin SOIC package
			40.3	°C/W	8-pin UDFN 3x3 mm package
TH03	TJMAX	Maximum Junction Temperature	150	°C	
TH04	PD	Power Dissipation	—	W	PD = PINTERNAL + P <sub>I/O</sub>
TH05	PINTERNAL	Internal Power Dissipation	—	W	PINTERNAL = IDD × VDD <sup>(1)</sup>
TH06	P <sub>I/O</sub>	I/O Power Dissipation	—	W	P <sub>I/O</sub> = Σ (IOL × VOL) + Σ (IOH × (VDD – VOH))
TH07	PDER	Derated Power	—	W	PDER = PDMAX (TJ – TA)/θJA <sup>(2)</sup>

**Note 1:** IDD is current to run the chip alone without driving any load on the output pins.

**Note 2:** TA = Ambient Temperature; TJ = Junction Temperature.

## 26.4 AC Characteristics

Timing Parameter Symbology has been created with one of the following formats:

1. TppS2ppS
2. TppS

<b>T</b> F            Frequency	T            Time
Lowercase letters (pp) and their meanings:	
<b>pp</b> cc            CCP1 ck            CLKOUT cs $\overline{CS}$ di            SDIx do            SDO dt            Data in io            I/O PORT mc $\overline{MCLR}$	osc            CLKIN rd $\overline{RD}$ rw $\overline{RD}$ or $\overline{WR}$ sc            SCKx ss $\overline{SS}$ t0            T0CKI t1            T1CKI wr $\overline{WR}$
Uppercase letters and their meanings:	
<b>S</b> F            Fall H            High I            Invalid (High-impedance) L            Low	P            Period R            Rise V            Valid Z            High-impedance

**FIGURE 26-4: LOAD CONDITIONS**

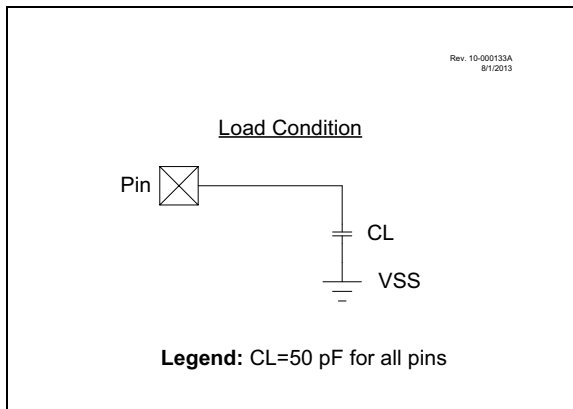

# PIC12(L)F1571/2

**FIGURE 26-5: CLOCK TIMING**

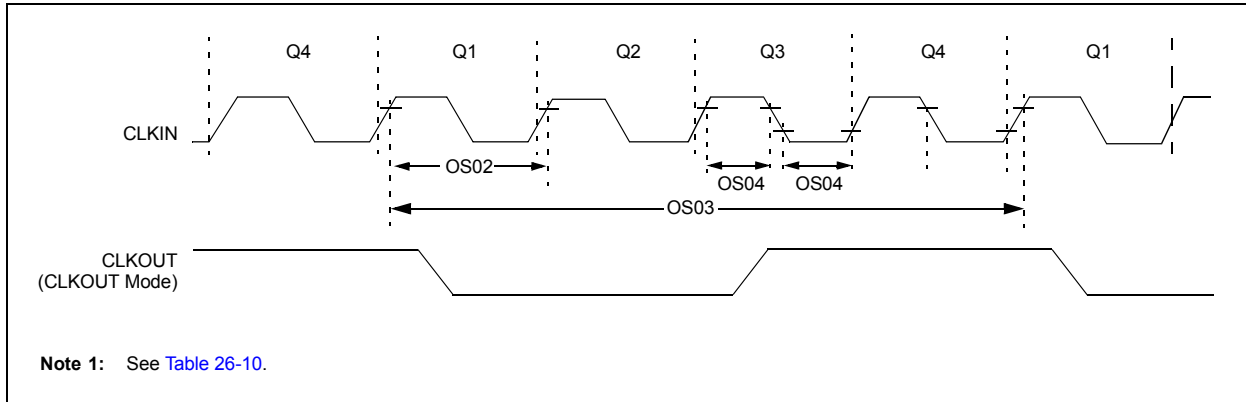

**TABLE 26-7: CLOCK OSCILLATOR TIMING REQUIREMENTS**

Standard Operating Conditions (unless otherwise stated)

Param. No.	Sym.	Characteristic	Min.	Typ†	Max.	Units	Conditions
OS01	Fosc	External CLKIN Frequency <sup>(1)</sup>	DC	—	0.5	MHz	External Clock (ECL)
			DC	—	4	MHz	External Clock (ECM)
			DC	—	20	MHz	External Clock (ECH)
OS02	Tosc	External CLKIN Period <sup>(1)</sup>	50	—	∞	ns	External Clock (EC)
OS03	Tcy	Instruction Cycle Time <sup>(1)</sup>	200	Tcy	DC	ns	Tcy = 4/Fosc

\* These parameters are characterized but not tested.

† Data in "Typ" column is at 3.0V, +25°C unless otherwise stated. These parameters are for design guidance only and are not tested.

**Note 1:** Instruction cycle period (Tcy) equals four times the input oscillator time base period. All specified values are based on characterization data for that particular oscillator type under standard operating conditions with the device executing code. Exceeding these specified limits may result in an unstable oscillator operation and/or higher than expected current consumption. All devices are tested to operate at "min" values with an external clock applied to the CLKIN pin. When an external clock input is used, the "max" cycle time limit is "DC" (no clock) for all devices.



**TABLE 26-8: OSCILLATOR PARAMETERS**

Standard Operating Conditions (unless otherwise stated)								
Param. No.	Sym.	Characteristic	Freq. Tolerance	Min.	Typ†	Max.	Units	Conditions
OS08	HFosc	Internal Calibrated HFINTOSC Frequency <sup>(1)</sup>	±2%	—	16.0	—	MHz	V <sub>DD</sub> = 3.0V, T <sub>A</sub> = 25°C (Note 2)
OS09	LFosc	Internal LFINTOSC Frequency	—	—	31	—	kHz	
OS10*	TWARM	HFINTOSC Wake-up from Sleep Start-up Time	—	—	5	15	μs	
		LFINTOSC Wake-up from Sleep Start-up Time	—	—	0.5	—	ms	

\* These parameters are characterized but not tested.

† Data in "Typ" column is at 3.0V, +25°C unless otherwise stated. These parameters are for design guidance only and are not tested.

**Note 1:** To ensure these oscillator frequency tolerances, V<sub>DD</sub> and V<sub>SS</sub> must be capacitively decoupled as close to the device as possible. 0.1 μF and 0.01 μF values in parallel are recommended.

**2:** See Figure 26-6: "HFINTOSC Frequency Accuracy Over Device V<sub>DD</sub> and Temperature."

**FIGURE 26-6: HFINTOSC FREQUENCY ACCURACY OVER DEVICE V<sub>DD</sub> AND TEMPERATURE**

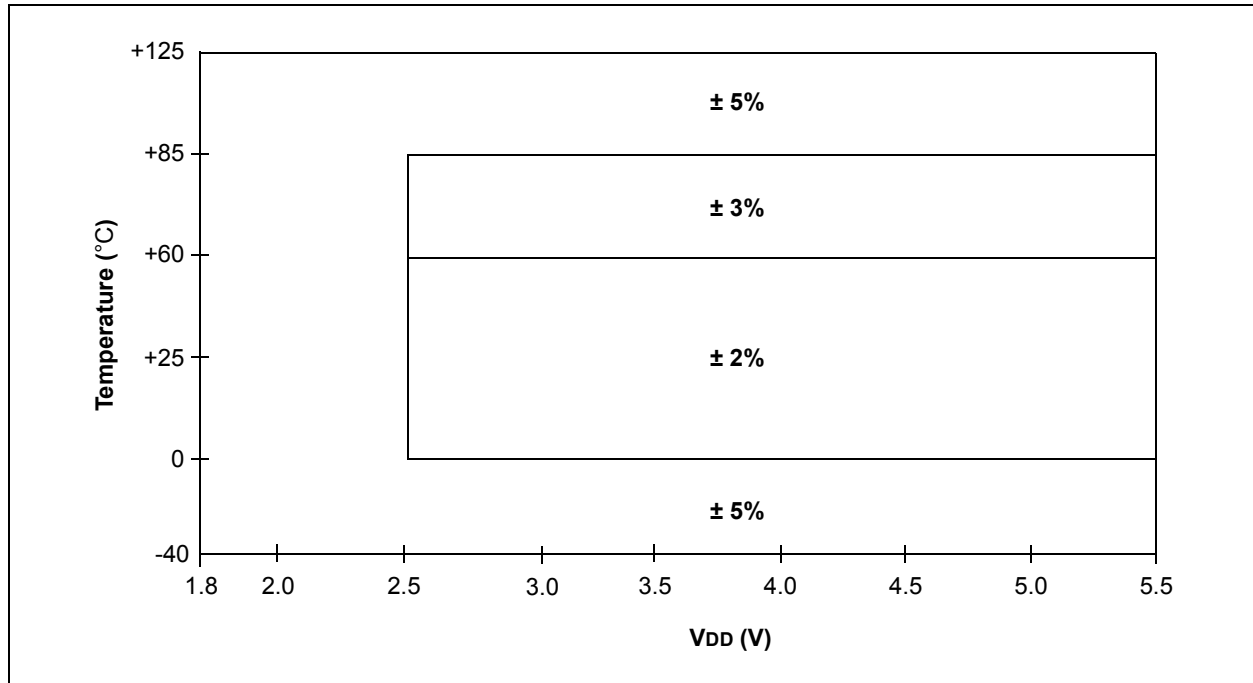

**TABLE 26-9: PLL CLOCK TIMING SPECIFICATIONS (V<sub>DD</sub> = 2.7V TO 5.5V)**

Param No.	Sym.	Characteristic	Min.	Typ†	Max.	Units	Conditions
F10	FOSC	Oscillator Frequency Range	4	—	8	MHz	
F11	FSYS	On-Chip VCO System Frequency	16	—	32	MHz	
F12	TRC	PLL Start-up Time (Lock Time)	—	—	2	ms	
F13*	ΔCLK	CLKOUT Stability (Jitter)	-0.25%	—	+0.25%	%	

\* These parameters are characterized but not tested.

† Data in "Typ" column is at 3V, +25°C unless otherwise stated. These parameters are for design guidance only and are not tested.

# PIC12(L)F1571/2

**FIGURE 26-7: CLKOUT AND I/O TIMING**

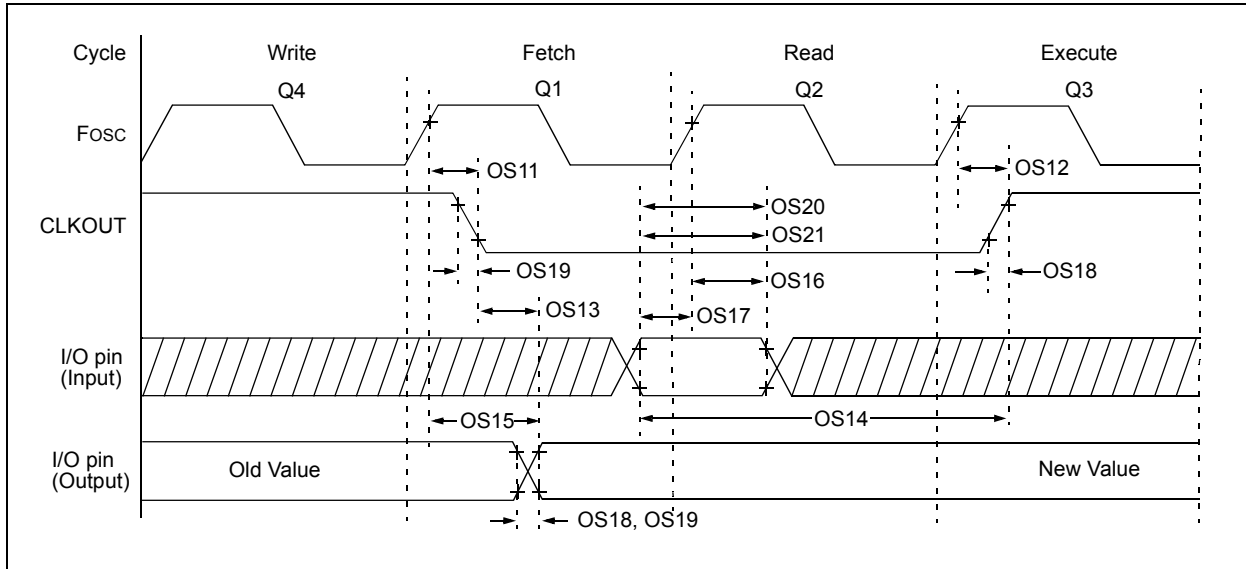

**TABLE 26-10: CLKOUT AND I/O TIMING PARAMETERS**

Standard Operating Conditions (unless otherwise stated)							
Param. No.	Sym.	Characteristic	Min.	Typ†	Max.	Units	Conditions
OS11	TosH2ckL	Fosc↑ to CLKOUT↓ <sup>(1)</sup>	—	—	70	ns	3.3V ≤ VDD ≤ 5.0V
OS12	TosH2ckH	Fosc↑ to CLKOUT↑ <sup>(1)</sup>	—	—	72	ns	3.3V ≤ VDD ≤ 5.0V
OS13	TckL2ioV	CLKOUT↓ to Port Out Valid <sup>(1)</sup>	—	—	20	ns	
OS14	TioV2ckH	Port Input Valid Before CLKOUT↑ <sup>(1)</sup>	Tosc + 200 ns	—	—	ns	
OS15	TosH2ioV	Fosc↑ (Q1 cycle) to Port Out Valid	—	50	70*	ns	3.3V ≤ VDD ≤ 5.0V
OS16	TosH2ioI	Fosc↑ (Q2 cycle) to Port Input Invalid (I/O in setup time)	50	—	—	ns	3.3V ≤ VDD ≤ 5.0V
OS17	TioV2osH	Port Input Valid to Fosc↑ (Q2 cycle) (I/O in setup time)	20	—	—	ns	
OS18*	TioR	Port Output Rise Time	—	40 15	72 32	ns	VDD = 1.8V, 3.3V ≤ VDD ≤ 5.0V
OS19*	TioF	Port Output Fall Time	—	28 15	55 30	ns	VDD = 1.8V, 3.3V ≤ VDD ≤ 5.0V
OS20*	Tinp	INT Pin Input High or Low Time	25	—	—	ns	
OS21*	Tioc	Interrupt-On-Change New Input Level Time	25	—	—	ns	

\* These parameters are characterized but not tested.

† Data in "Typ" column is at 3.0V, +25°C unless otherwise stated.

**Note 1:** Measurements are taken in EXTRC mode where CLKOUT output is 4 x Tosc.

FIGURE 26-8: RESET, WATCHDOG TIMER, OSCILLATOR START-UP TIMER AND POWER-UP TIMER TIMING

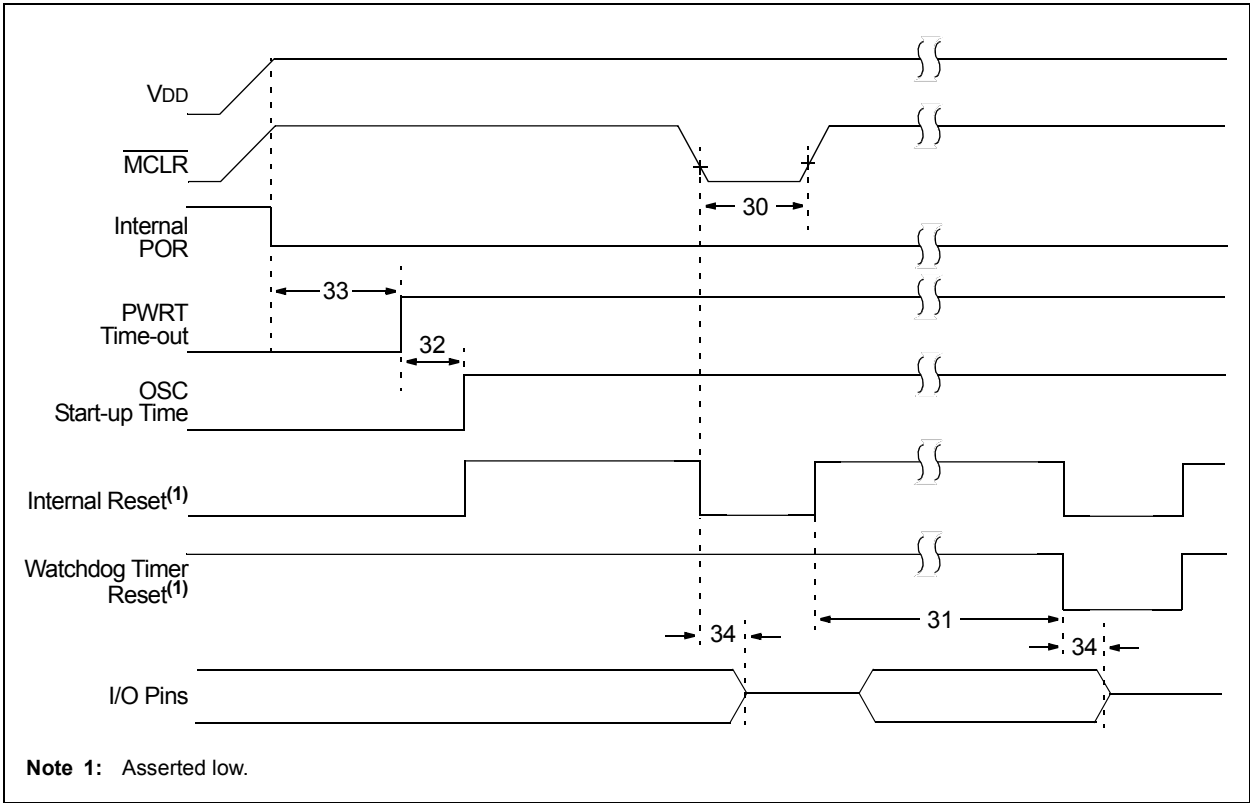

# PIC12(L)F1571/2

**TABLE 26-11: RESET, WATCHDOG TIMER, OSCILLATOR START-UP TIMER, POWER-UP TIMER AND BROWN-OUT RESET PARAMETERS**

Standard Operating Conditions (unless otherwise stated)							
Param. No.	Sym.	Characteristic	Min.	Typ†	Max.	Units	Conditions
30	TMCL	MCLR Pulse Width (low)	2	—	—	μs	
31	TWDTLP	Low-Power Watchdog Timer Time-out Period	10	16	27	ms	VDD = 3.3V-5V, 1:512 prescaler used
32	TOST	Oscillator Start-up Timer Period <sup>(1)</sup>	—	1024	—	TOSC	
33*	TPWRT	Power-up Timer Period	40	65	140	ms	PWRTE = 0
34*	TIOZ	I/O High-Impedance from MCLR Low or Watchdog Timer Reset	—	—	2.0	μs	
35	VBOR	Brown-out Reset Voltage <sup>(2)</sup>	2.55 2.35 1.80	2.70 2.45 1.90	2.85 2.58 2.05	V	BORV = 0 BORV = 1 (PIC12F1571/2) BORV = 1 (PIC12LF1571/2)
36*	VHYST	Brown-out Reset Hysteresis	0	25	60	mV	-40°C ≤ TA ≤ +85°C
37*	TBORDC	Brown-out Reset DC Response Time	1	16	35	μs	VDD ≤ VBOR
38	VLBOR	Low-Power Brown-out Reset Voltage	1.8	2.1	2.5	V	LPBOR = 1

\* These parameters are characterized but not tested.

† Data in "Typ" column is at 3.0V, +25°C unless otherwise stated. These parameters are for design guidance only and are not tested.

**Note 1:** By design, the Oscillator Start-up Timer (OST) counts the first 1024 cycles, independent of frequency.

**Note 2:** To ensure these voltage tolerances, VDD and VSS must be capacitively decoupled as close to the device as possible. 0.1 μF and 0.01 μF values in parallel are recommended.

**FIGURE 26-9: BROWN-OUT RESET TIMING AND CHARACTERISTICS**

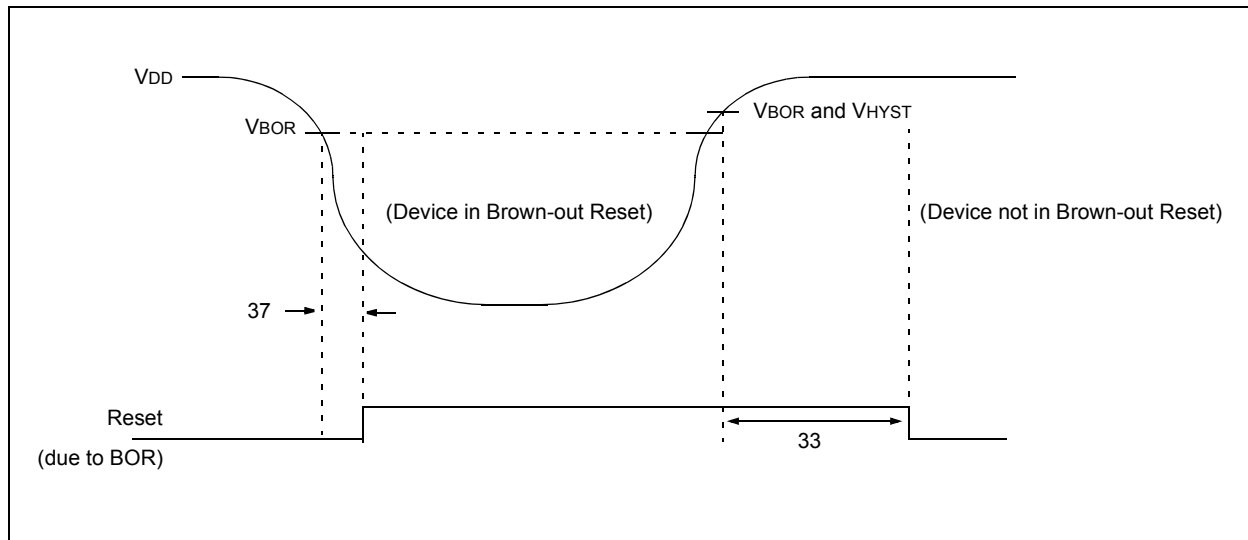

**FIGURE 26-10: TIMER0 AND TIMER1 EXTERNAL CLOCK TIMINGS**

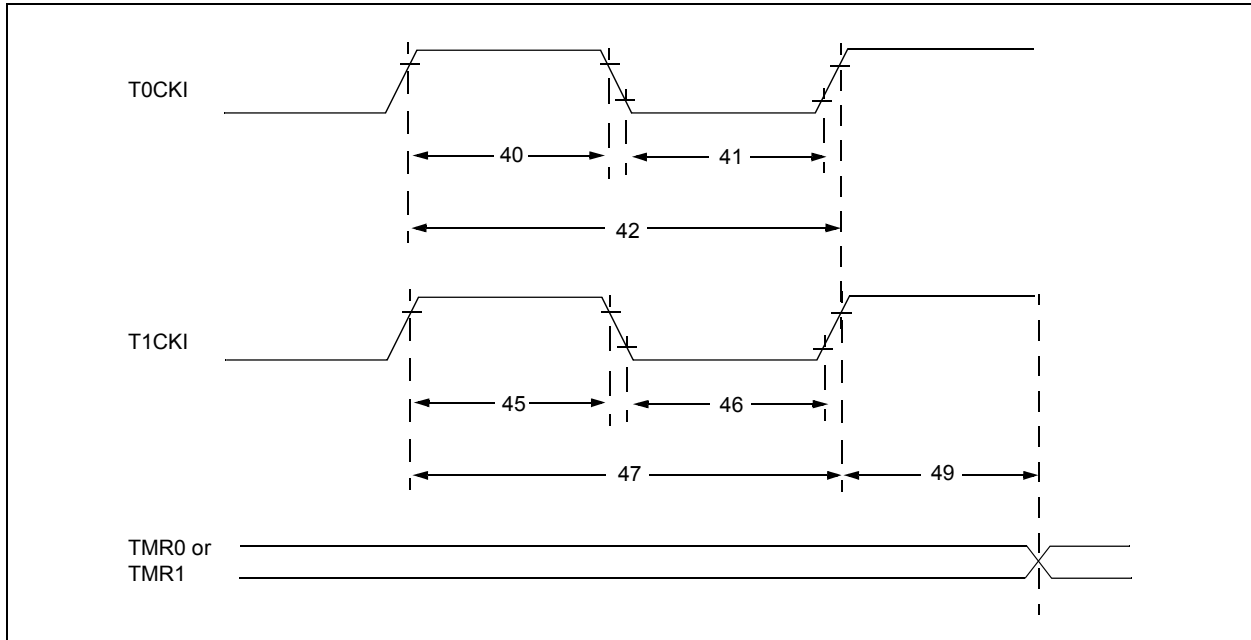

**TABLE 26-12: TIMER0 AND TIMER1 EXTERNAL CLOCK REQUIREMENTS**

Standard Operating Conditions (unless otherwise stated)								
Param. No.	Sym.	Characteristic		Min.	Typ†	Max.	Units	Conditions
40*	Tt0H	T0CKI High Pulse Width	No Prescaler	$0.5 T_{CY} + 20$	—	—	ns	
			With Prescaler	10	—	—	ns	
41*	Tt0L	T0CKI Low Pulse Width	No Prescaler	$0.5 T_{CY} + 20$	—	—	ns	
			With Prescaler	10	—	—	ns	
42*	Tt0P	T0CKI Period		Greater of: $20$ or $\frac{T_{CY} + 40}{N}$	—	—	ns	N = Prescale value
45*	Tt1H	T1CKI High Time	Synchronous, No Prescaler	$0.5 T_{CY} + 20$	—	—	ns	
			Synchronous, with Prescaler	15	—	—	ns	
			Asynchronous	30	—	—	ns	
46*	Tt1L	T1CKI Low Time	Synchronous, No Prescaler	$0.5 T_{CY} + 20$	—	—	ns	
			Synchronous, with Prescaler	15	—	—	ns	
			Asynchronous	30	—	—	ns	
47*	Tt1P	T1CKI Input Period	Synchronous	Greater of: $30$ or $\frac{T_{CY} + 40}{N}$	—	—	ns	N = Prescale value
			Asynchronous	60	—	—	ns	
49*	TCKEZTMR1	Delay from External Clock Edge to Timer Increment		$2 T_{osc}$	—	$7 T_{osc}$	—	Timers in Sync mode

\* These parameters are characterized but not tested.

† Data in "Typ" column is at 3.0V, +25°C unless otherwise stated. These parameters are for design guidance only and are not tested.

# PIC12(L)F1571/2

**TABLE 26-13: ANALOG-TO-DIGITAL CONVERTER (ADC) CHARACTERISTICS<sup>(1,2,3)</sup>**

Operating Conditions (unless otherwise stated) V <sub>DD</sub> = 3.0V, T <sub>A</sub> = +25°C							
Param. No.	Sym.	Characteristic	Min.	Typ†	Max.	Units	Conditions
AD01	NR	Resolution	—	—	10	bit	
AD02	EIL	Integral Error	—	±1	±1.7	LSb	V <sub>REF</sub> = 3.0V
AD03	EDL	Differential Error	—	±1	±1	LSb	No missing codes, V <sub>REF</sub> = 3.0V
AD04	E <sub>OFF</sub>	Offset Error	—	±1	±2.5	LSb	V <sub>REF</sub> = 3.0V
AD05	E <sub>GN</sub>	Gain Error	—	±1	±2.0	LSb	V <sub>REF</sub> = 3.0V
AD06	V <sub>REF</sub>	Reference Voltage	1.8	—	V <sub>DD</sub>	V	V <sub>REF</sub> = (V <sub>RPOS</sub> – V <sub>RNEG</sub> ) ( <b>Note 4</b> )
AD07	V <sub>AIN</sub>	Full-Scale Range	V <sub>SS</sub>	—	V <sub>REF</sub>	V	
AD08	Z <sub>AIN</sub>	Recommended Impedance of Analog Voltage Source	—	—	10	kΩ	Can go higher if external 0.01 μF capacitor is present on input pin.

\* These parameters are characterized but not tested.

† Data in “Typ” column is at 3.0V, +25°C unless otherwise stated. These parameters are for design guidance only and are not tested.

**Note 1:** Total absolute error includes integral, differential, offset and gain errors.

**2:** The ADC conversion result never decreases with an increase in the input voltage and has no missing codes.

**3:** See [Section 27.0 “DC and AC Characteristics Graphs and Charts”](#) for operating characterization.

**4:** ADC V<sub>REF</sub> is selected by the ADPREF<0> bit.

FIGURE 26-11: ADC CONVERSION TIMING (ADC CLOCK Fosc-BASED)

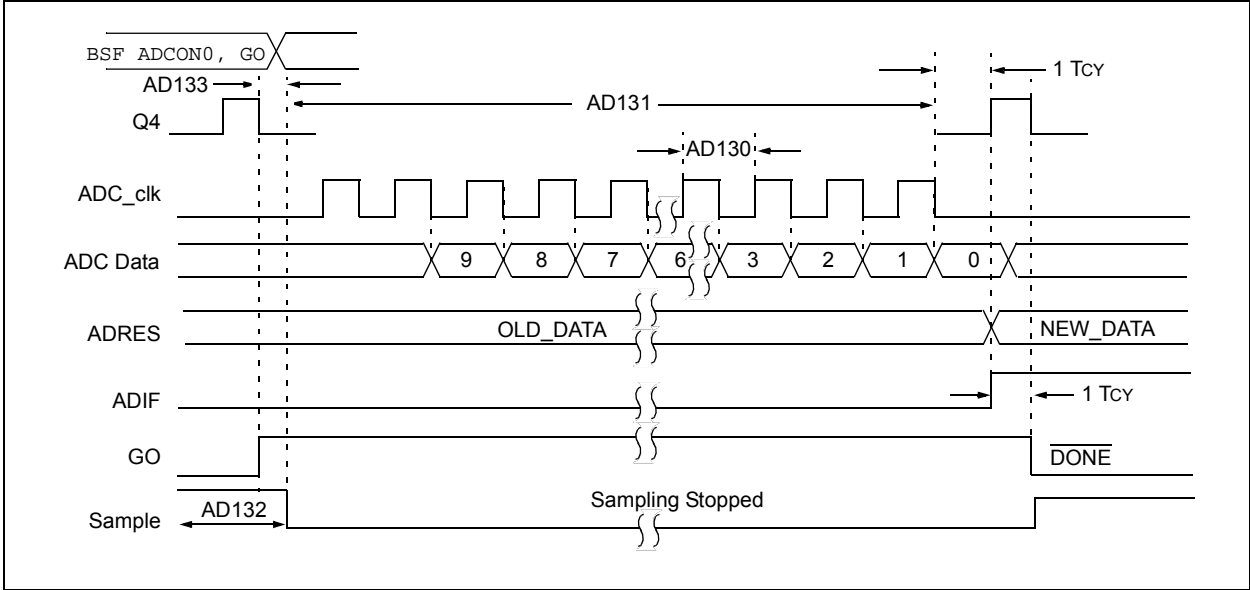
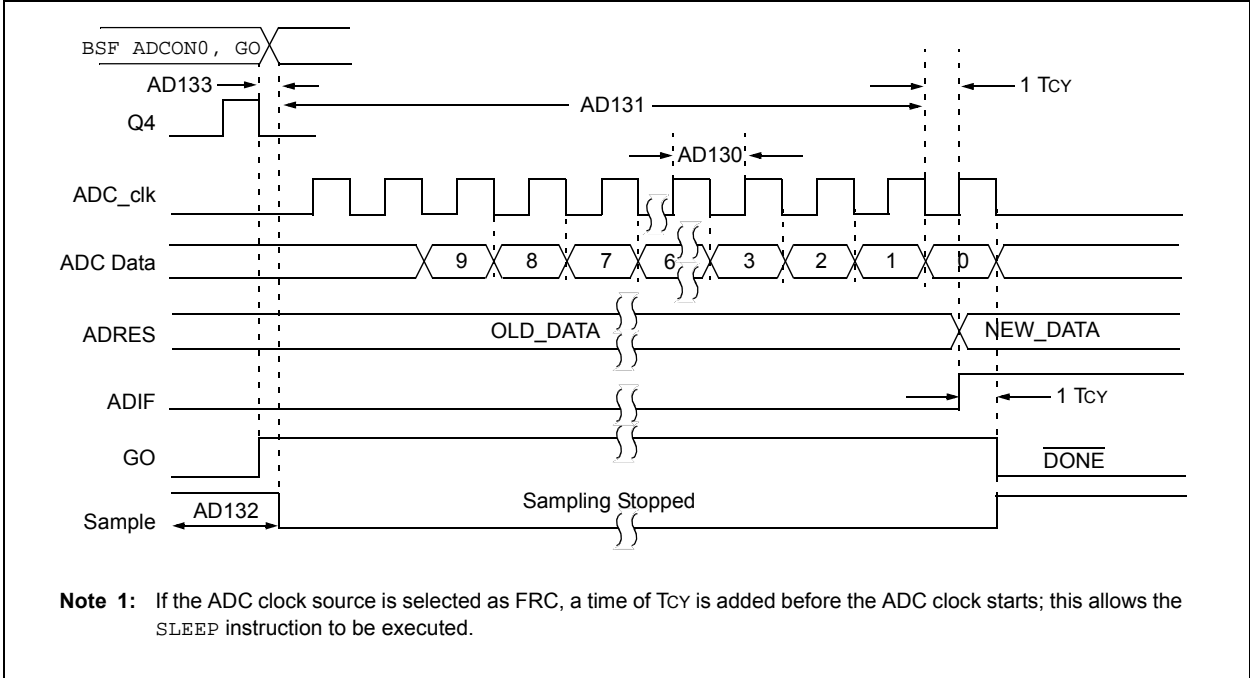

FIGURE 26-12: ADC CONVERSION TIMING (ADC CLOCK FROM FRC)



# PIC12(L)F1571/2

**TABLE 26-14: ADC CONVERSION REQUIREMENTS**

Standard Operating Conditions (unless otherwise stated)							
Param. No.	Sym.	Characteristic	Min.	Typ†	Max.	Units	Conditions
AD130*	TAD	ADC Clock Period (TADC)	1.0	—	6.0	μs	FOSC-based
		ADC Internal FRC Oscillator Period (TFRC)	1.0	2.0	6.0	μs	ADCS<2:0> = x11 (ADC FRC mode)
AD131	TCNV	Conversion Time (not including Acquisition Time) <sup>(1)</sup>	—	11	—	TAD	Set GO/DONE bit to conversion complete
AD132*	TACQ	Acquisition Time	—	5.0	—	μs	
AD133*	THCD	Holding Capacitor Disconnect Time	—	1/2 TAD	—		FOSC-based, ADCS<2:0> = x11 (ADC FRC mode)
			—	1/2 TAD + 1TCY	—		

\* These parameters are characterized but not tested.

† Data in "Typ" column is at 3.0V, +25°C unless otherwise stated. These parameters are for design guidance only and are not tested.

**Note 1:** The ADRES register may be read on the following T<sub>CY</sub> cycle.



**TABLE 26-15: COMPARATOR SPECIFICATIONS<sup>(1)</sup>**

Operating Conditions (unless otherwise stated) V <sub>DD</sub> = 3.0V, T <sub>A</sub> = +25°C							
Param. No.	Sym.	Characteristics	Min.	Typ.	Max.	Units	Comments
CM01	V <sub>IOFF</sub>	Input Offset Voltage	—	±7.5	±60	mV	C <sub>x</sub> SP = 1, V <sub>ICM</sub> = V <sub>DD</sub> /2
CM02	V <sub>ICM</sub>	Input Common-Mode Voltage	0	—	V <sub>DD</sub>	V	
CM03	CMRR	Common-Mode Rejection Ratio	—	50	—	dB	
CM04A	T <sub>RESP</sub> <sup>(2)</sup>	Response Time Rising Edge	—	400	800	ns	C <sub>x</sub> SP = 1
CM04B		Response Time Falling Edge	—	200	400	ns	C <sub>x</sub> SP = 1
CM04C		Response Time Rising Edge	—	1200	—	ns	C <sub>x</sub> SP = 0
CM04D		Response Time Falling Edge	—	550	—	ns	C <sub>x</sub> SP = 0
CM05*	T <sub>MC2OV</sub>	Comparator Mode Change to Output Valid	—	—	10	µs	
CM06	CHYSTER	Comparator Hysteresis	—	25	—	mV	C <sub>x</sub> HYS = 1, C <sub>x</sub> SP = 1

\* These parameters are characterized but not tested.

**Note 1:** See [Section 27.0 “DC and AC Characteristics Graphs and Charts”](#) for operating characterization.

**2:** Response time measured with one comparator input at V<sub>DD</sub>/2, while the other input transitions from V<sub>SS</sub> to V<sub>DD</sub>.

**TABLE 26-16: DIGITAL-TO-ANALOG CONVERTER (DAC) SPECIFICATIONS<sup>(1)</sup>**

Operating Conditions (unless otherwise stated) V <sub>DD</sub> = 3.0V, T <sub>A</sub> = +25°C							
Param. No.	Sym.	Characteristics	Min.	Typ.	Max.	Units	Comments
DAC01*	CLSB	Step Size	—	V <sub>DD</sub> /32	—	V	
DAC02*	CACC	Absolute Accuracy	—	—	± 1/2	LSb	
DAC03*	CR	Unit Resistor Value (R)	—	5K	—	Ω	
DAC04*	CST	Settling Time <sup>(2)</sup>	—	—	10	µs	

\* These parameters are characterized but not tested.

**Note 1:** See [Section 27.0 “DC and AC Characteristics Graphs and Charts”](#) for operating characterization.

**2:** Settling time measured while DACR<4:0> transitions from ‘0000’ to ‘1111’.

# PIC12(L)F1571/2

**FIGURE 26-13: USART SYNCHRONOUS TRANSMISSION (MASTER/SLAVE) TIMING**

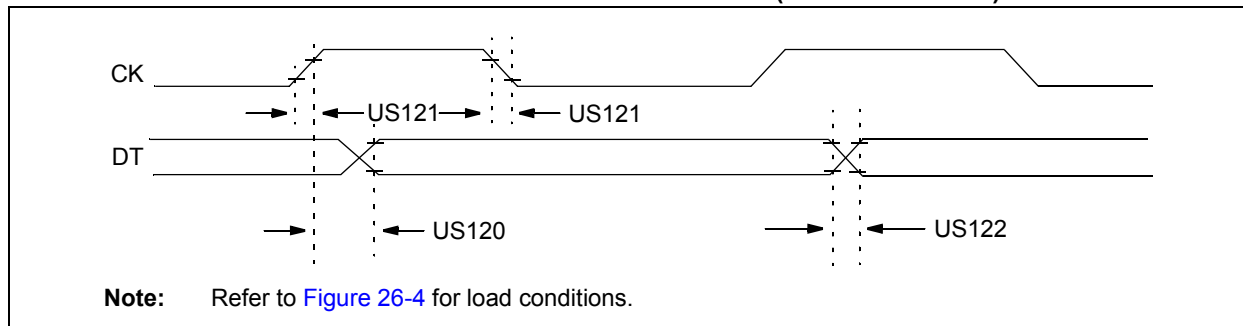

**TABLE 26-17: USART SYNCHRONOUS TRANSMISSION REQUIREMENTS**

Standard Operating Conditions (unless otherwise stated)						
Param. No.	Symbol	Characteristic	Min.	Max.	Units	Conditions
US120	T <sub>CKH2DTV</sub>	SYNC XMIT (Master and Slave) Clock High to Data-Out Valid	—	80	ns	3.0V ≤ V <sub>DD</sub> ≤ 5.5V
			—	100	ns	1.8V ≤ V <sub>DD</sub> ≤ 5.5V
US121	T <sub>CKRF</sub>	Clock Out Rise Time and Fall Time (Master mode)	—	45	ns	3.0V ≤ V <sub>DD</sub> ≤ 5.5V
			—	50	ns	1.8V ≤ V <sub>DD</sub> ≤ 5.5V
US122	T <sub>DTRF</sub>	Data-Out Rise Time and Fall Time	—	45	ns	3.0V ≤ V <sub>DD</sub> ≤ 5.5V
			—	50	ns	1.8V ≤ V <sub>DD</sub> ≤ 5.5V

**FIGURE 26-14: USART SYNCHRONOUS RECEIVE (MASTER/SLAVE) TIMING**

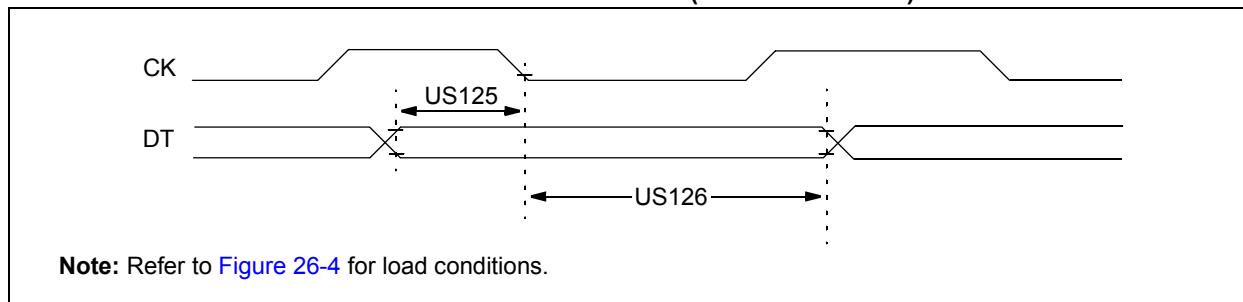

**TABLE 26-18: USART SYNCHRONOUS RECEIVE REQUIREMENTS**

Standard Operating Conditions (unless otherwise stated)						
Param. No.	Symbol	Characteristic	Min.	Max.	Units	Conditions
US125	T <sub>DTV2CKL</sub>	SYNC RCV (Master and Slave) Data-Hold before CK ↓ (DT hold time)	10	—	ns	
US126	T <sub>CKL2DTL</sub>	Data-Hold after CK ↓ (DT hold time)	15	—	ns	

## 27.0 DC AND AC CHARACTERISTICS GRAPHS AND CHARTS

The graphs and tables provided in this section are for **design guidance** and are **not tested**.

In some graphs or tables, the data presented is **outside specified operating range** (i.e., outside specified  $V_{DD}$  range). This is for **information only** and devices are ensured to operate properly only within the specified range.

<p><b>Note:</b> The graphs and tables provided following this note are a statistical summary based on a limited number of samples and are provided for informational purposes only. The performance characteristics listed herein are not tested or guaranteed. In some graphs or tables, the data presented may be outside the specified operating range (e.g., outside specified power supply range) and therefore, outside the warranted range.</p>
--

**“Typical”** represents the mean of the distribution at +25°C. **“MAXIMUM”**, **“Max.”**, **“MINIMUM”** or **“Min.”** represents  $(\text{mean} + 3\sigma)$  or  $(\text{mean} - 3\sigma)$  respectively, where  $\sigma$  is a standard deviation over each temperature range.

# PIC12(L)F1571/2

FIGURE 27-1:  $I_{DD}$ , EC OSCILLATOR, LOW-POWER MODE,  $F_{osc} = 32$  kHz, PIC12LF1571/2 ONLY

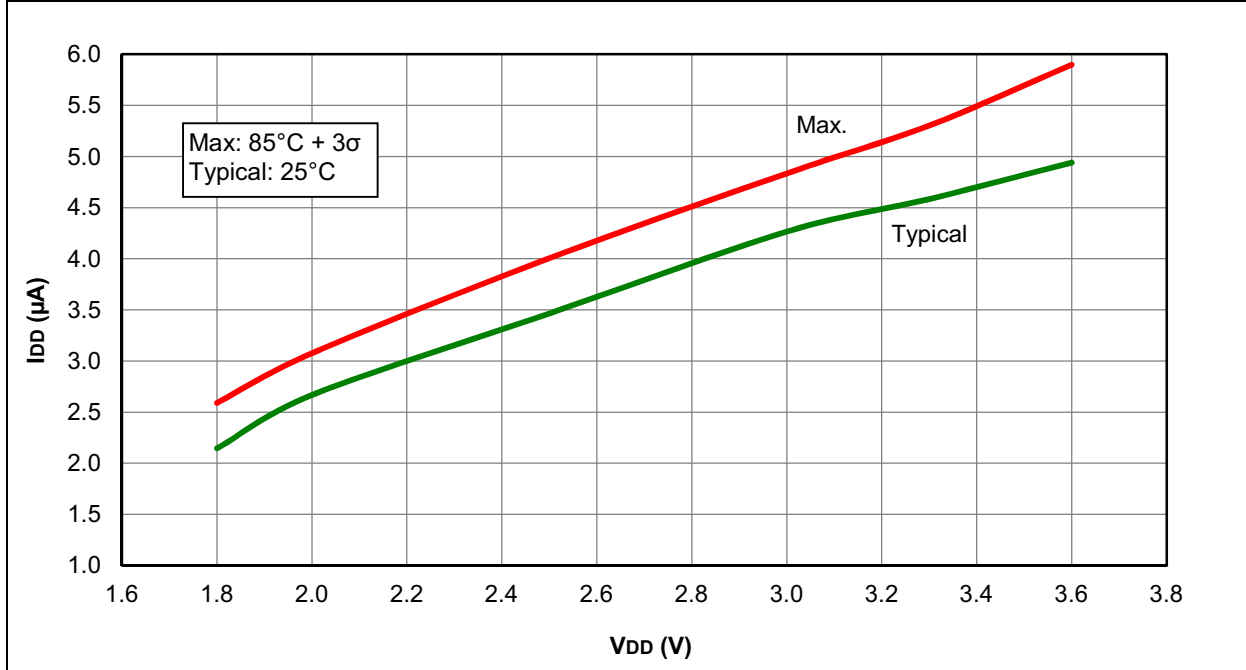

FIGURE 27-2:  $I_{DD}$ , EC OSCILLATOR, LOW-POWER MODE,  $F_{osc} = 32$  kHz, PIC12F1571/2 ONLY

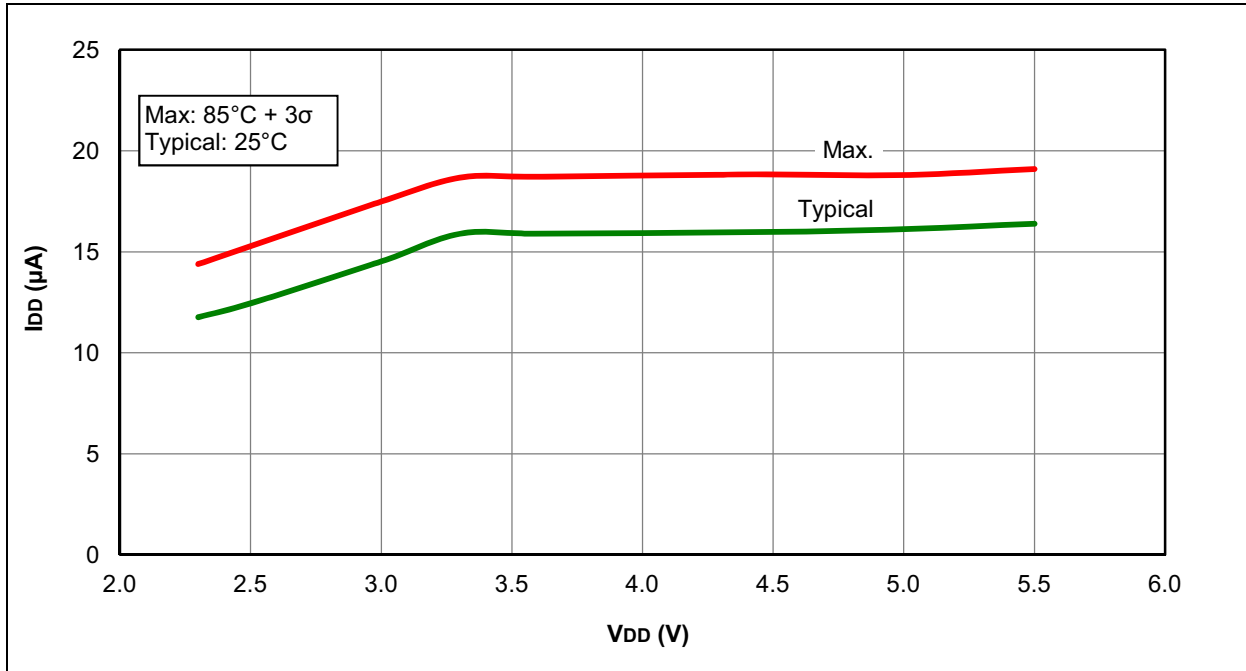

FIGURE 27-3: I<sub>DD</sub>, EC OSCILLATOR, LOW-POWER MODE, F<sub>osc</sub> = 500 kHz, PIC12LF1571/2 ONLY

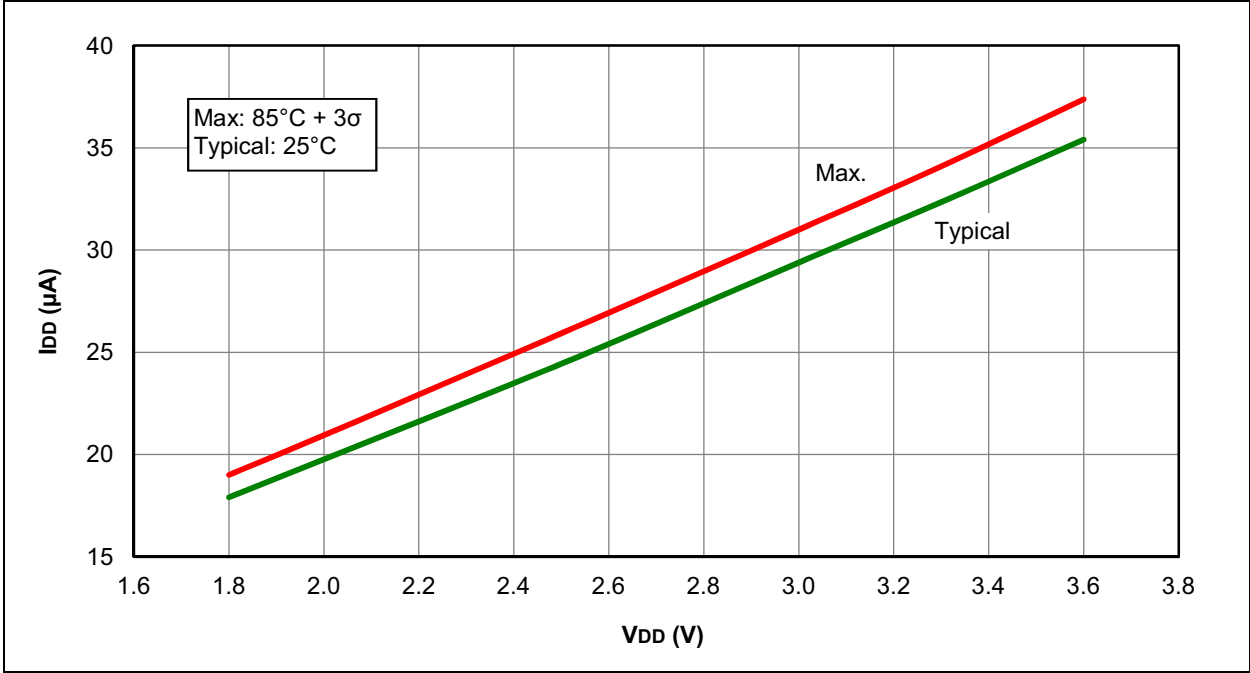
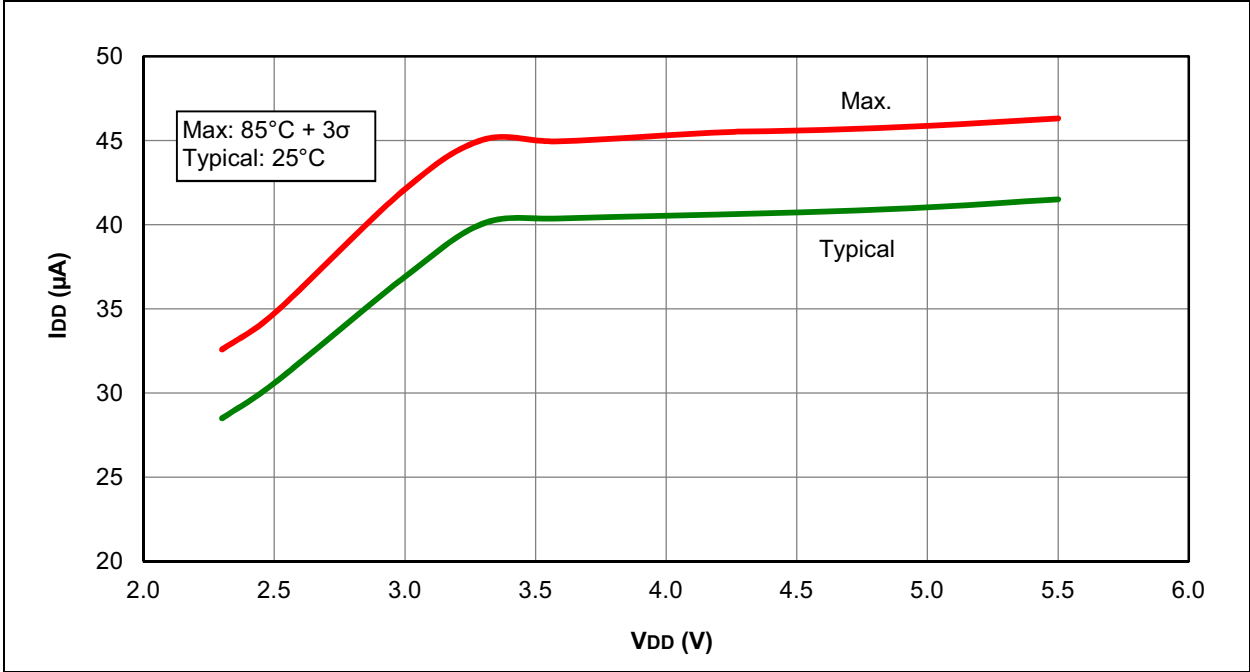

FIGURE 27-4: I<sub>DD</sub>, EC OSCILLATOR, LOW-POWER MODE, F<sub>osc</sub> = 500 kHz, PIC12F1571/2 ONLY



# PIC12(L)F1571/2

FIGURE 27-5: I<sub>DD</sub> TYPICAL, EC OSCILLATOR, MEDIUM POWER MODE, PIC12LF1571/2 ONLY

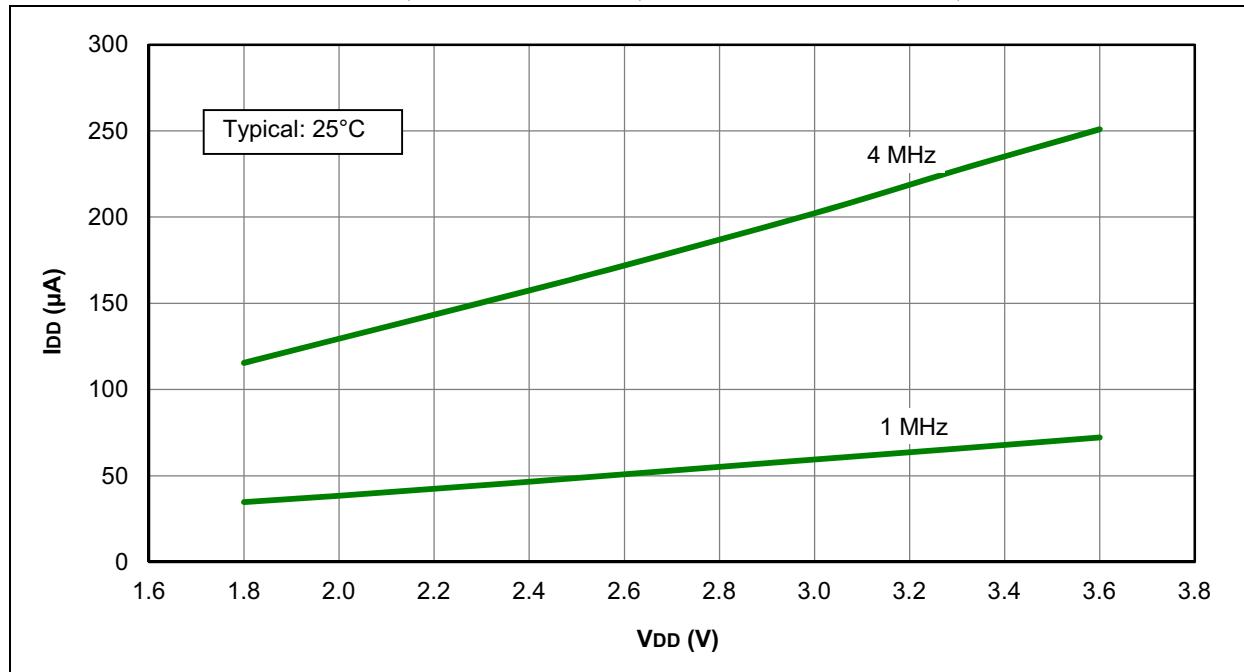
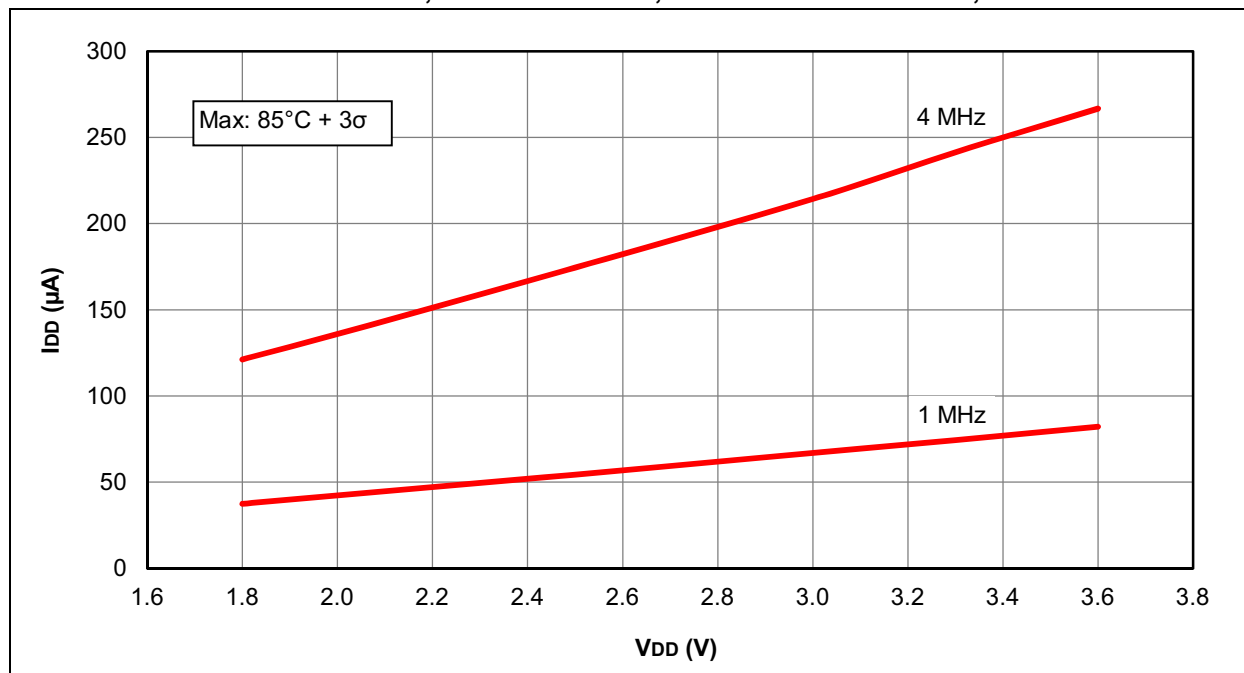
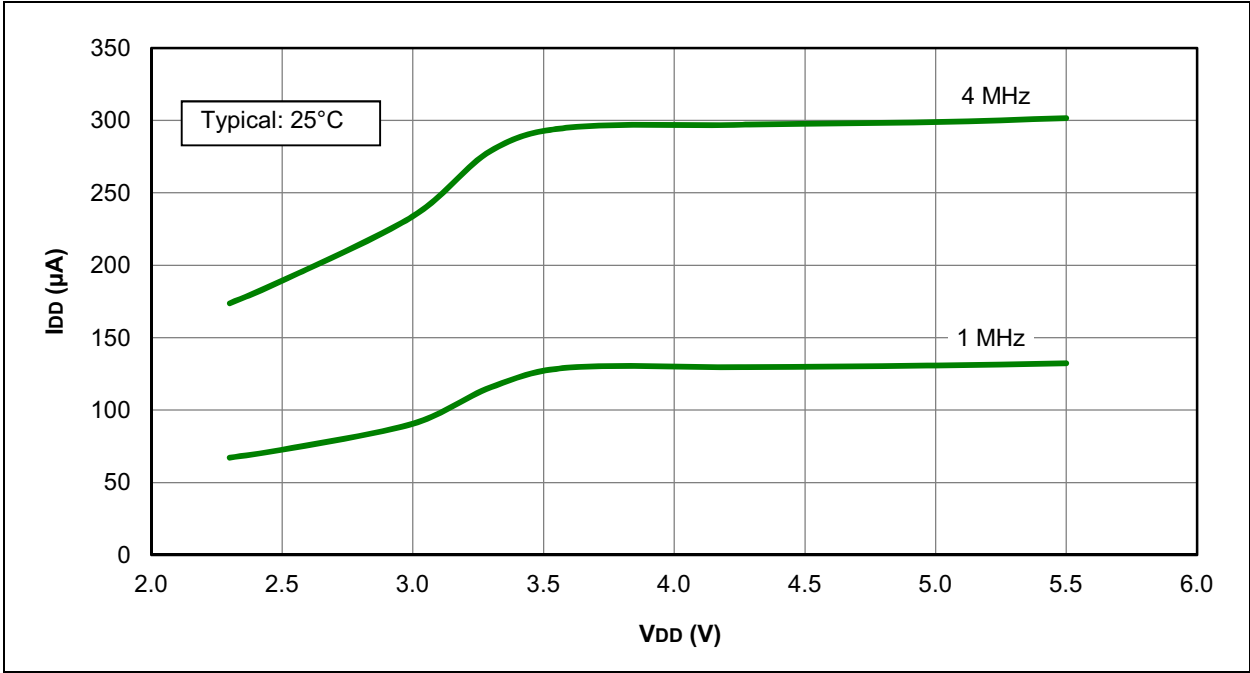

FIGURE 27-6: I<sub>DD</sub> MAXIMUM, EC OSCILLATOR, MEDIUM POWER MODE, PIC12LF1571/2 ONLY



**FIGURE 27-7: I<sub>DD</sub> TYPICAL, EC OSCILLATOR, MEDIUM POWER MODE, PIC12F1571/2 ONLY**



**FIGURE 27-8: I<sub>DD</sub> MAXIMUM, EC OSCILLATOR, MEDIUM POWER MODE, PIC12F1571/2 ONLY**

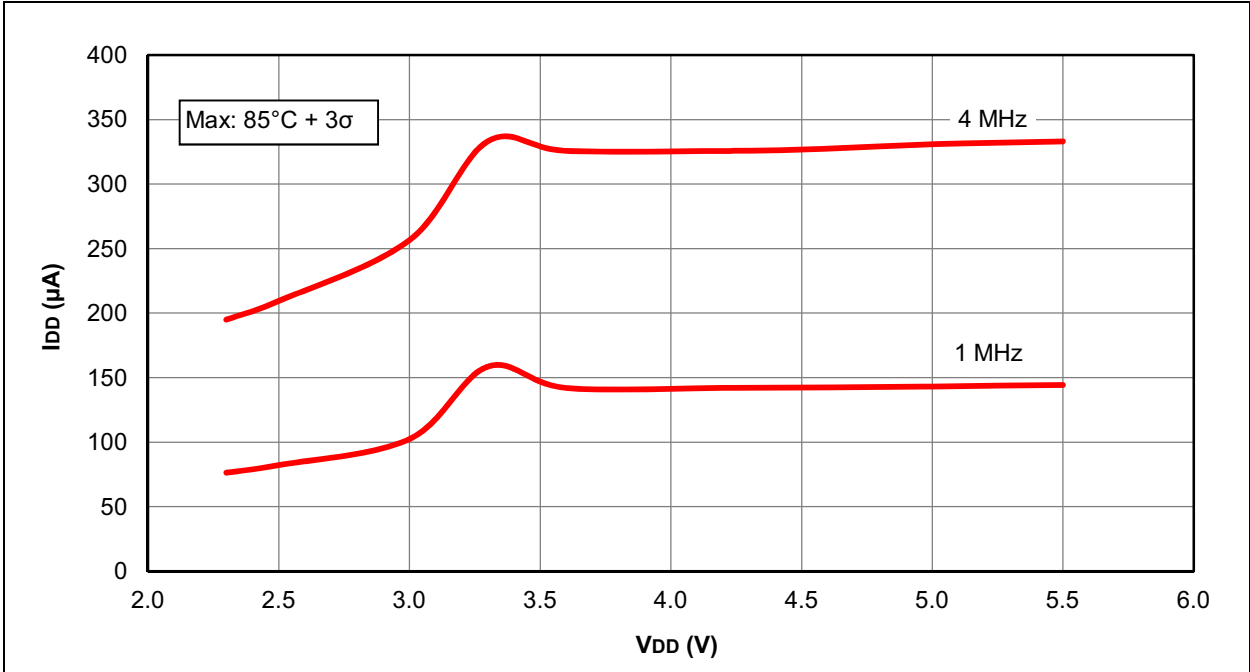

# PIC12(L)F1571/2

FIGURE 27-9: I<sub>DD</sub> TYPICAL, EC OSCILLATOR, HIGH-POWER MODE, PIC12LF1571/2 ONLY

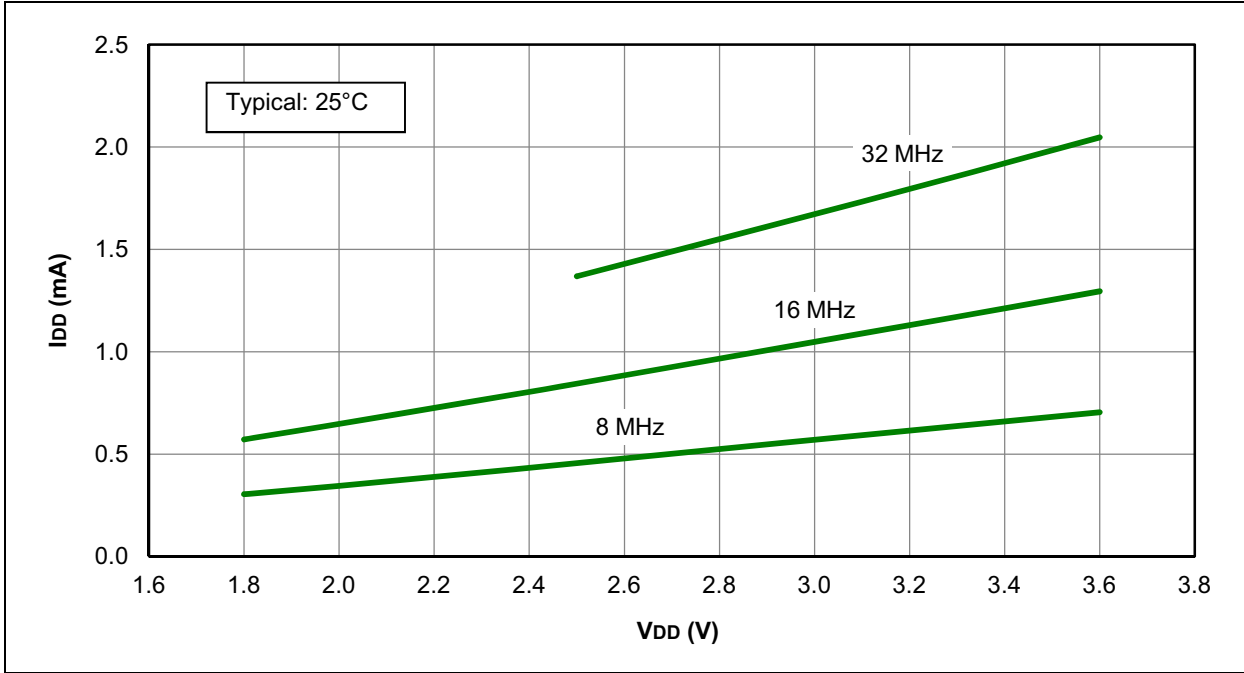
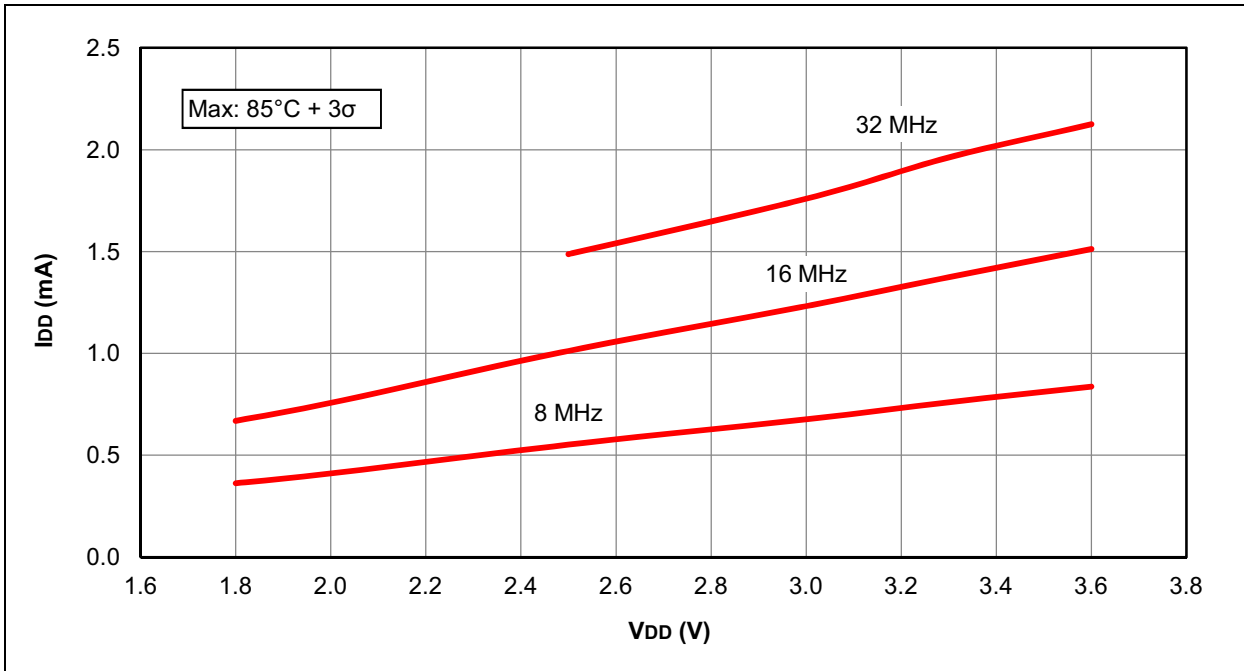
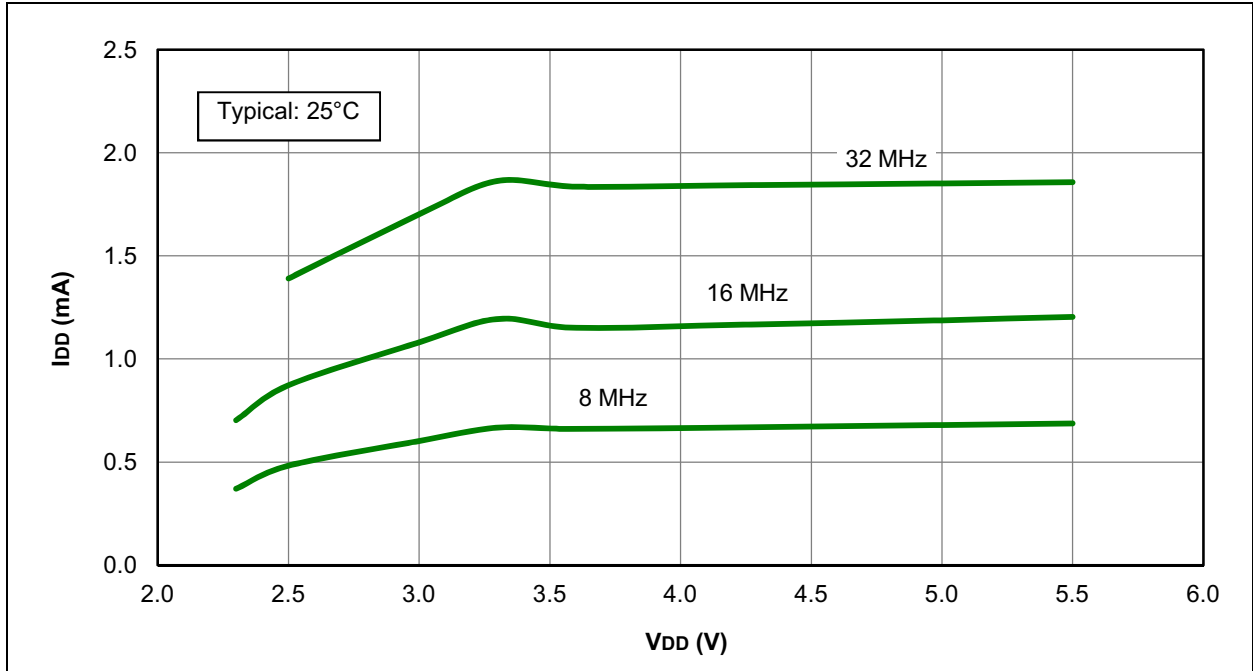

FIGURE 27-10: I<sub>DD</sub> MAXIMUM, EC OSCILLATOR, HIGH-POWER MODE, PIC12LF1571/2 ONLY

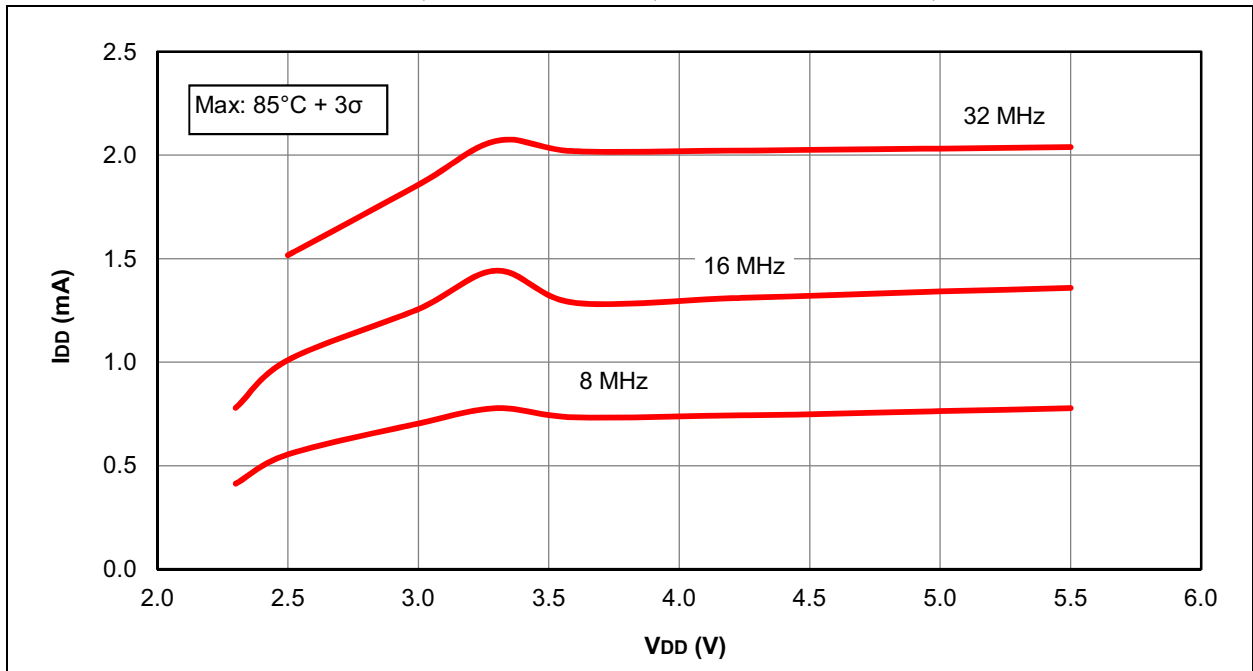



**FIGURE 27-11: I<sub>DD</sub> TYPICAL, EC OSCILLATOR, HIGH-POWER MODE, PIC12F1571/2 ONLY**



**FIGURE 27-12: I<sub>DD</sub> MAXIMUM, EC OSCILLATOR, HIGH-POWER MODE, PIC12F1571/2 ONLY**



# PIC12(L)F1571/2

FIGURE 27-13:  $I_{DD}$ , LFINTOSC,  $F_{osc} = 31$  kHz, PIC12LF1571/2 ONLY

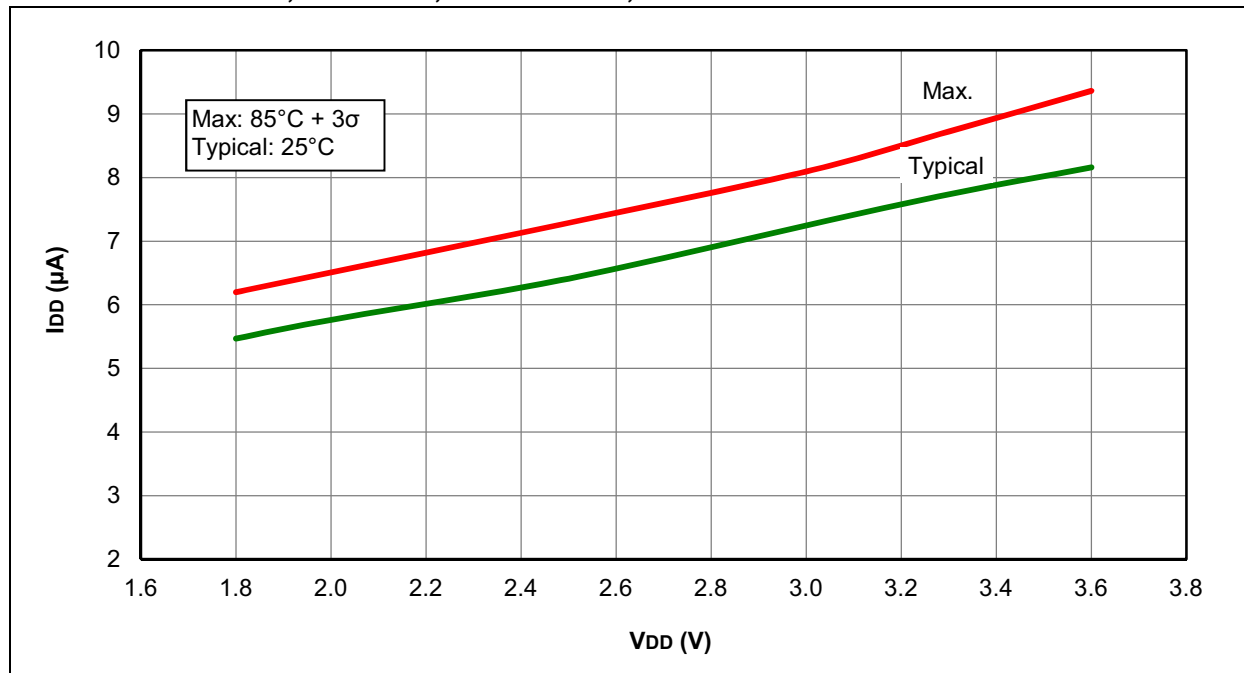
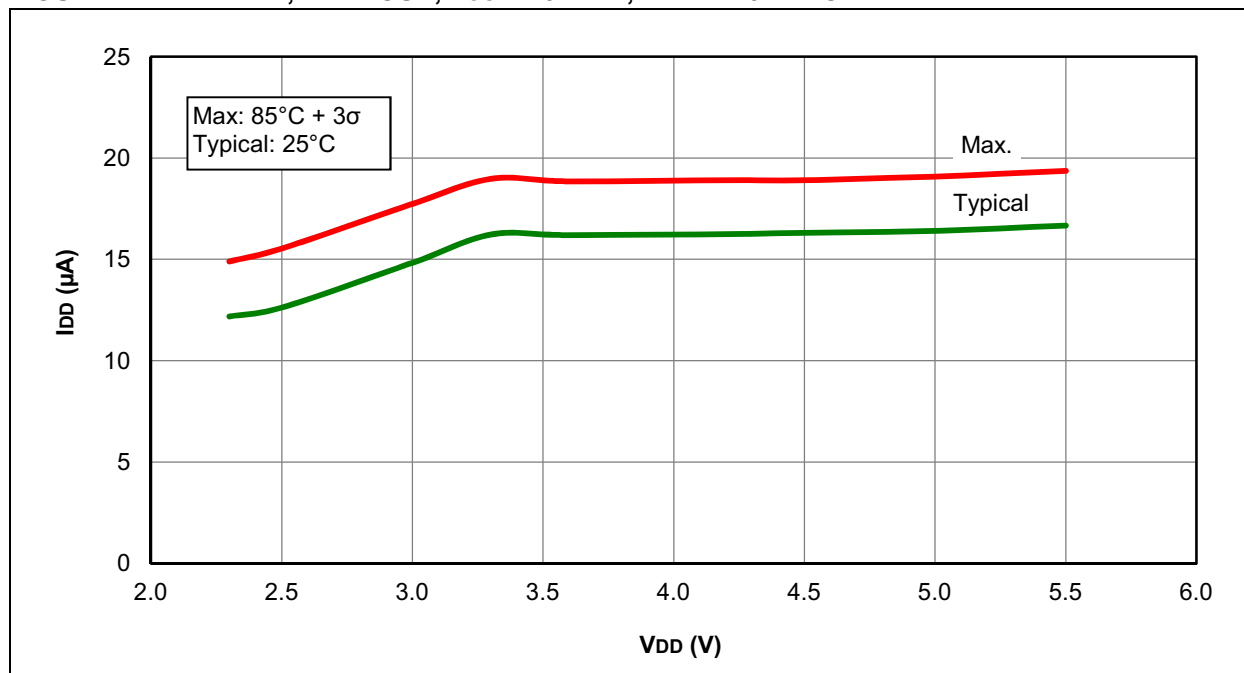
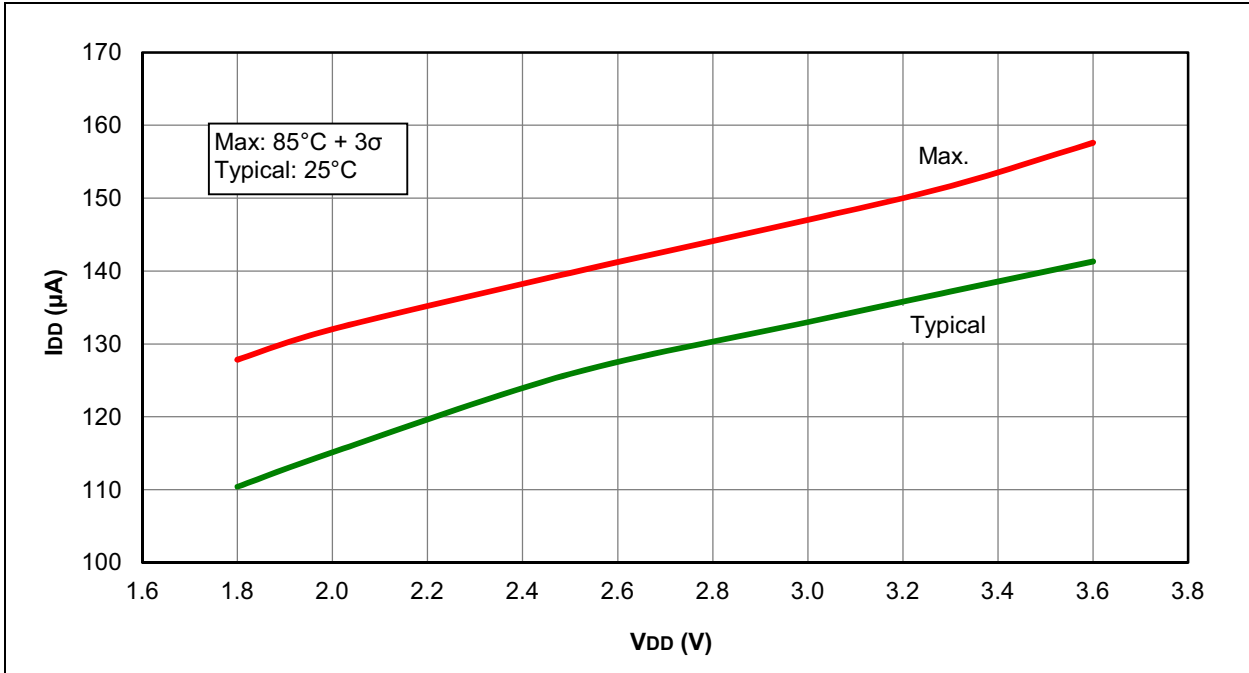

FIGURE 27-14:  $I_{DD}$ , LFINTOSC,  $F_{osc} = 31$  kHz, PIC12F1571/2 ONLY



**FIGURE 27-15: I<sub>DD</sub>, MFINTOSC, Fosc = 500 kHz, PIC12LF1571/2 ONLY**



**FIGURE 27-16: I<sub>DD</sub>, MFINTOSC, Fosc = 500 kHz, PIC12F1571/2 ONLY**

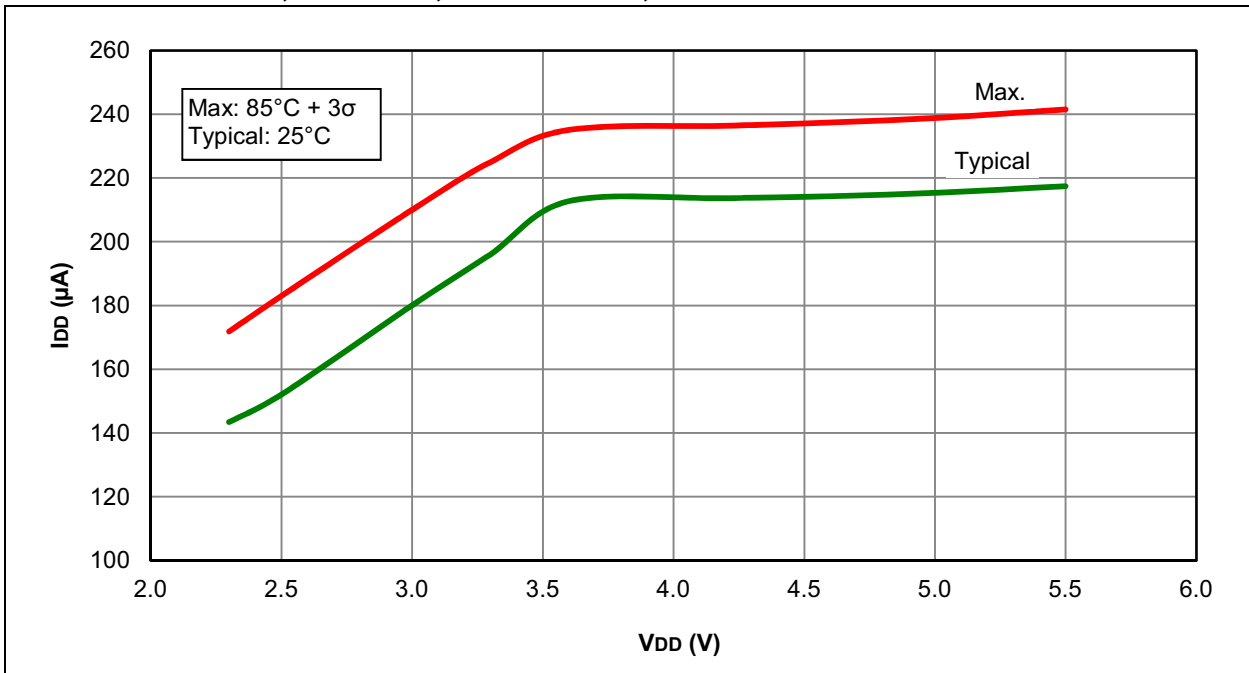

# PIC12(L)F1571/2

FIGURE 27-17: I<sub>DD</sub> TYPICAL, HFINTOSC, PIC12LF1571/2 ONLY

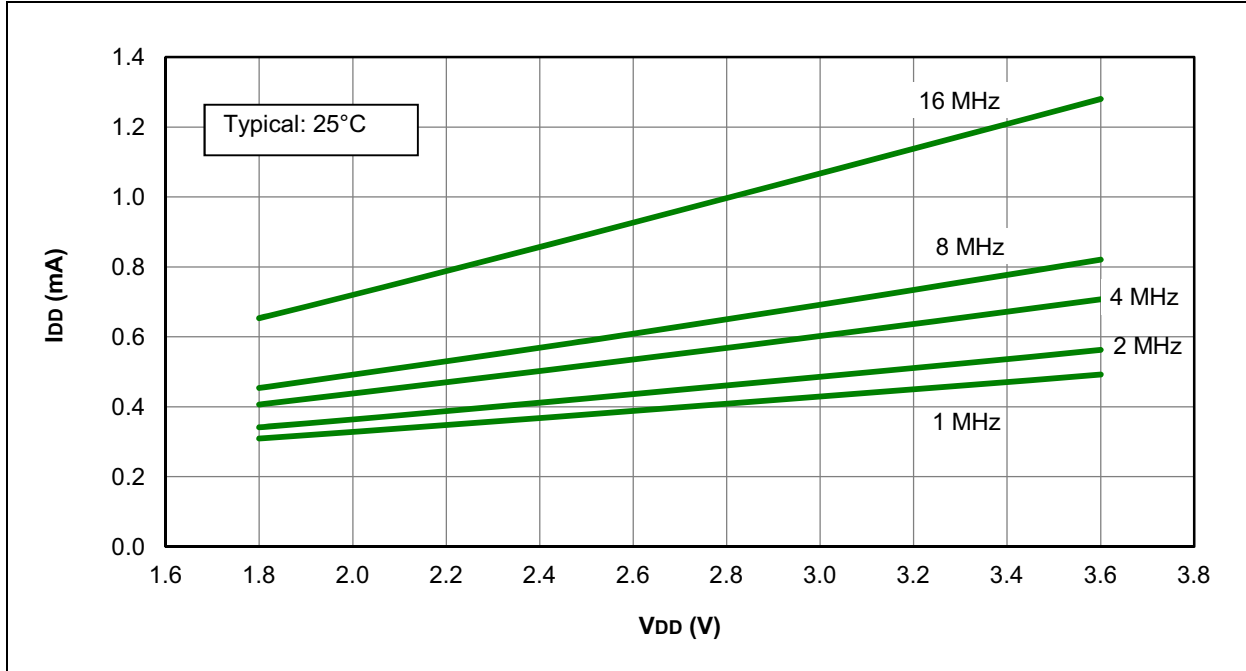
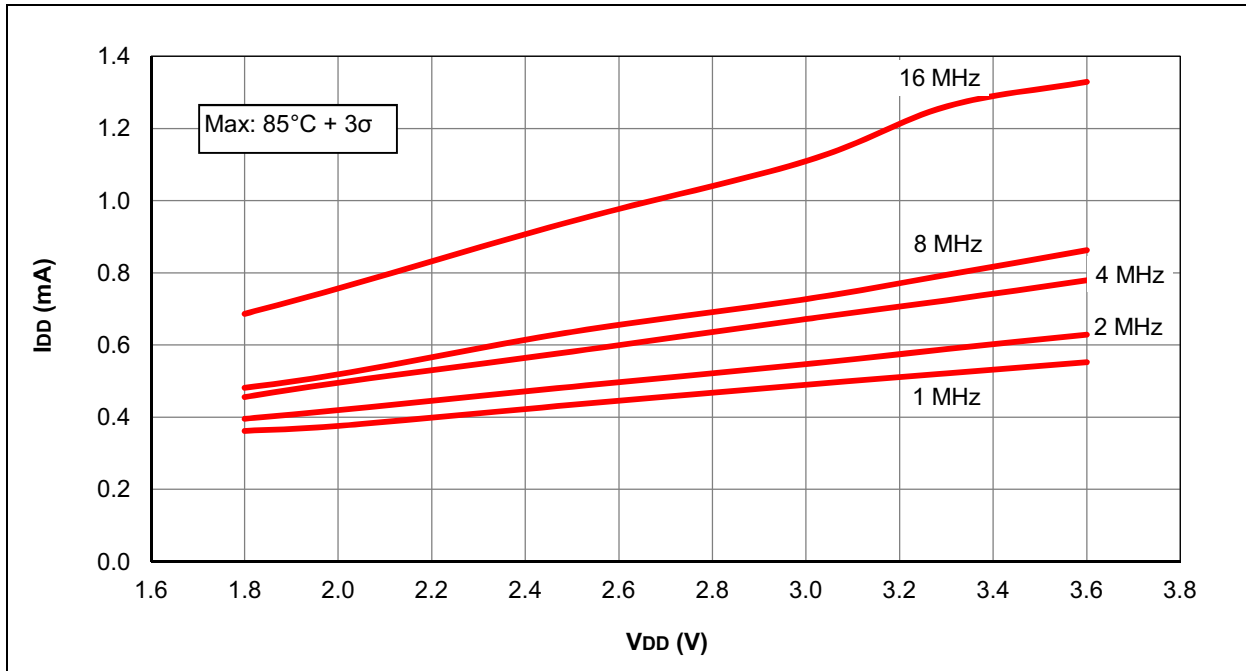
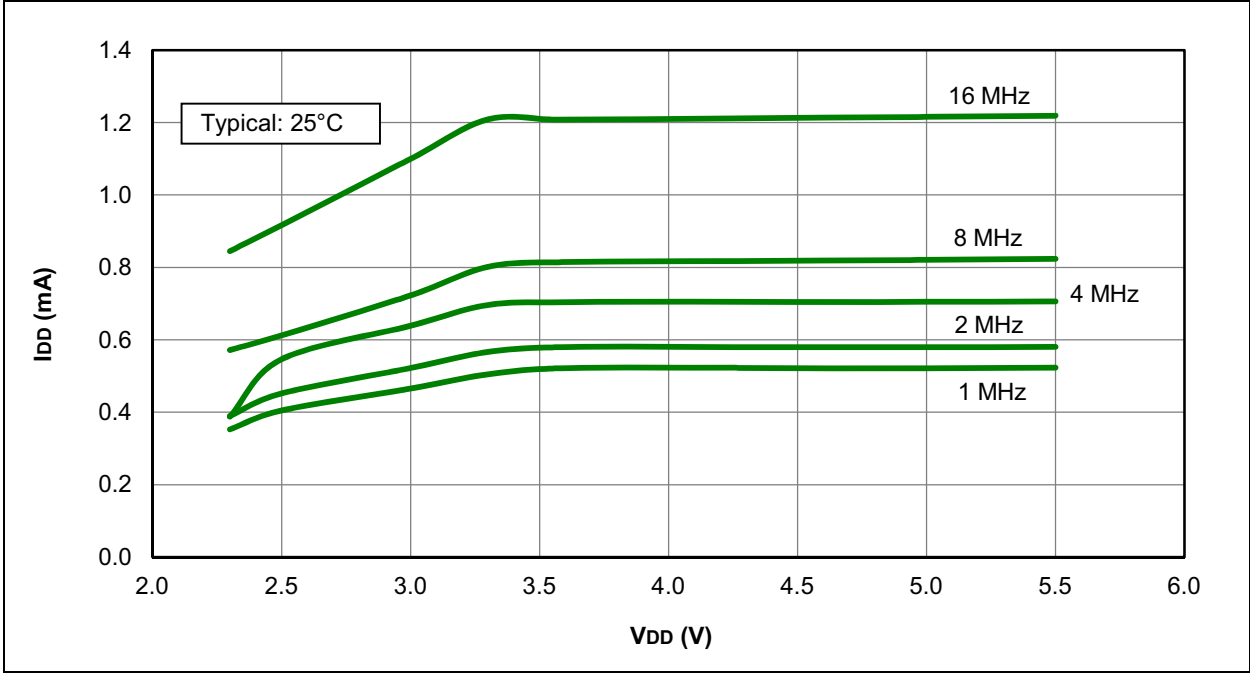

FIGURE 27-18: I<sub>DD</sub> MAXIMUM, HFINTOSC, PIC12LF1571/2 ONLY



**FIGURE 27-19: I<sub>DD</sub> TYPICAL, HFINTOSC, PIC12F1571/2 ONLY**



**FIGURE 27-20: I<sub>DD</sub> MAXIMUM, HFINTOSC, PIC12F1571/2 ONLY**

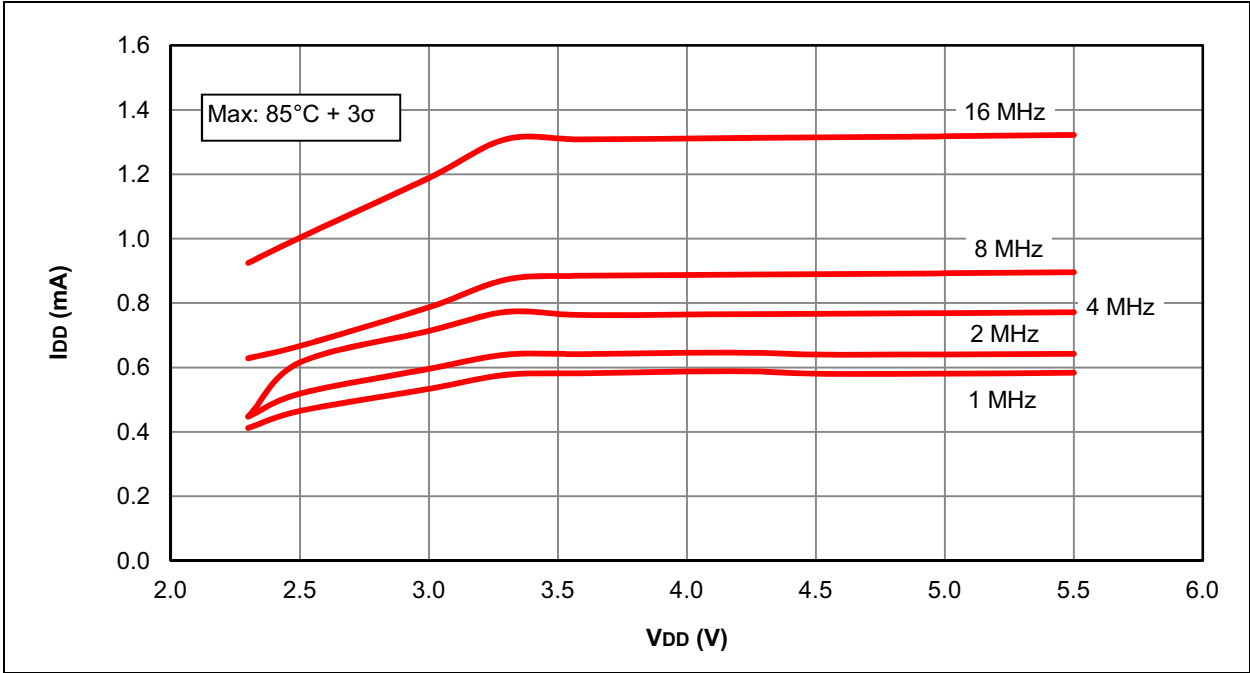

# PIC12(L)F1571/2

FIGURE 27-21: I<sub>PD</sub> BASE, LOW-POWER SLEEP MODE, PIC12LF1571/2 ONLY

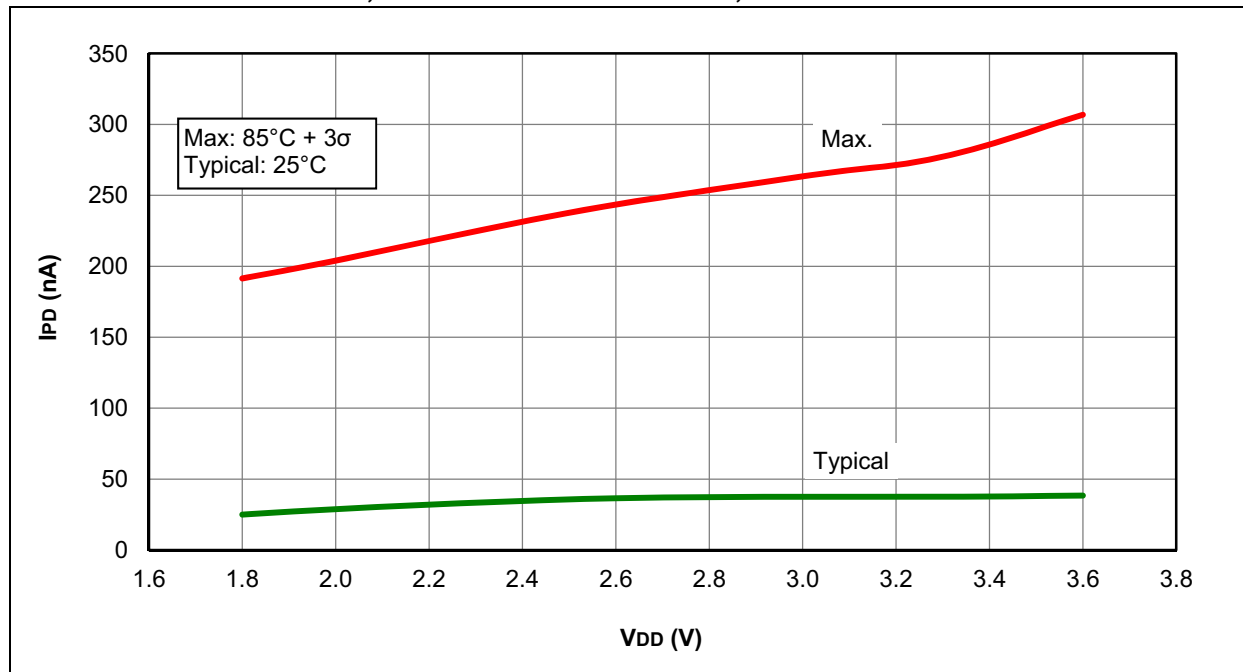
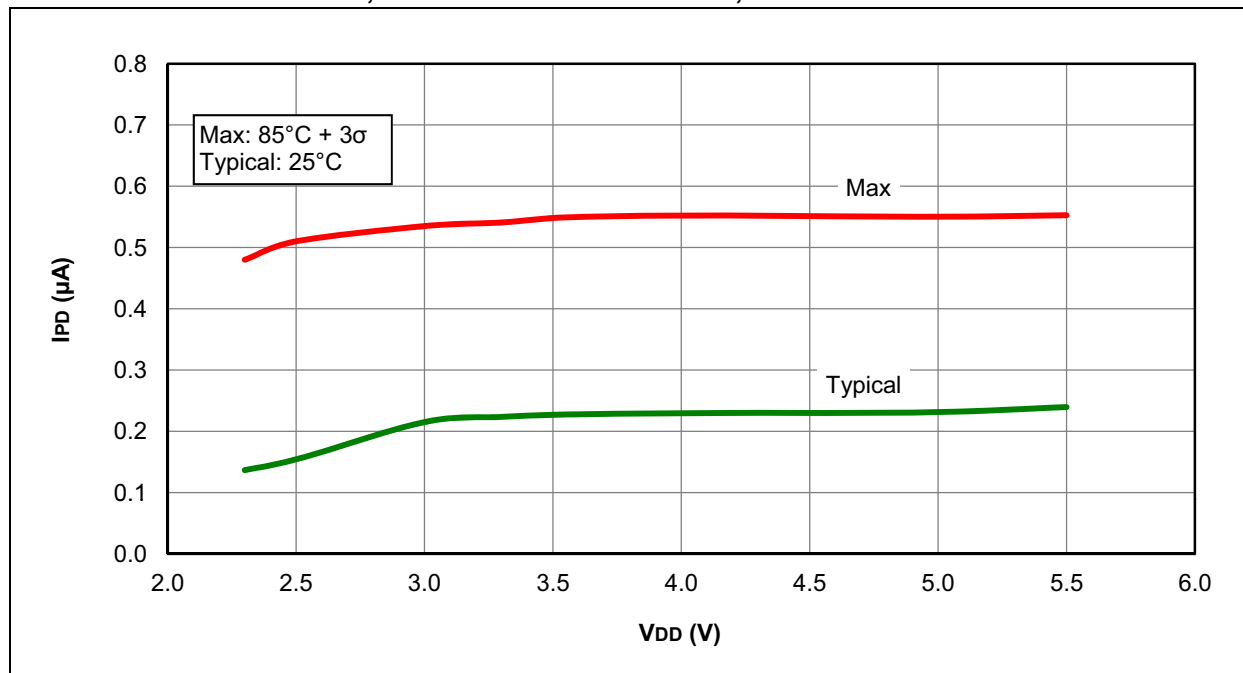
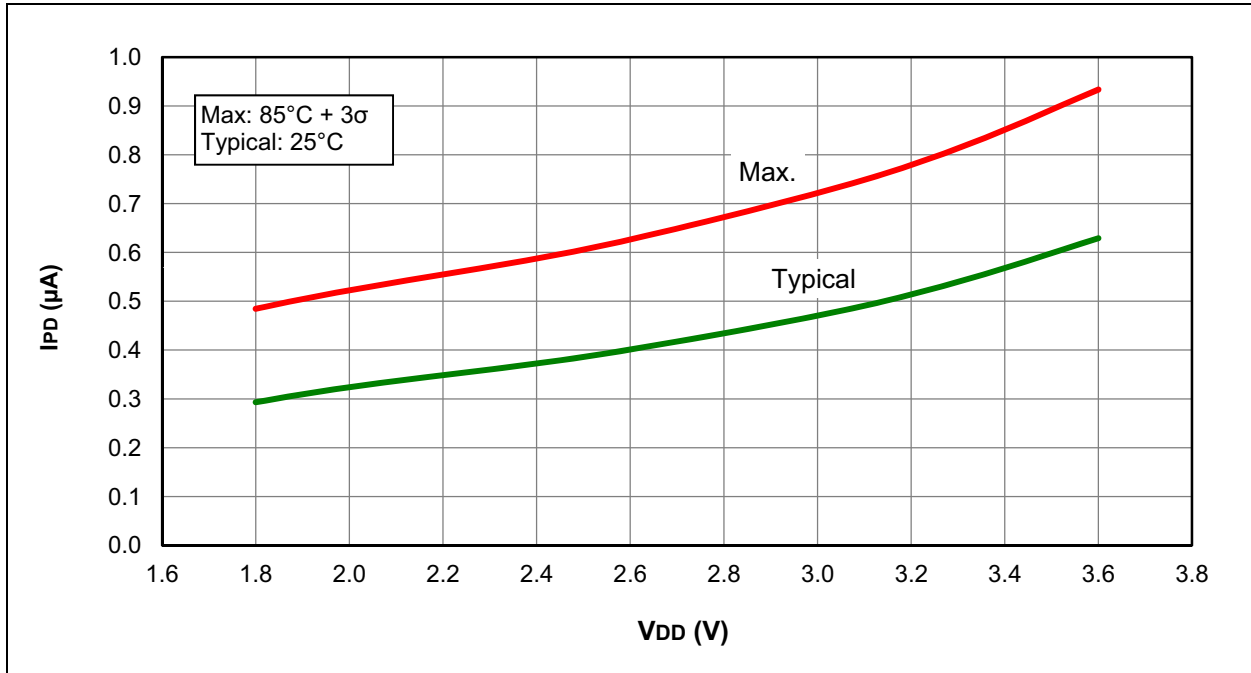

FIGURE 27-22: I<sub>PD</sub> BASE, LOW-POWER SLEEP MODE, PIC12F1571/2 ONLY



**FIGURE 27-23: IPD, WATCHDOG TIMER (WDT), PIC12LF1571/2 ONLY**



**FIGURE 27-24: IPD, WATCHDOG TIMER (WDT), PIC12F1571/2 ONLY**

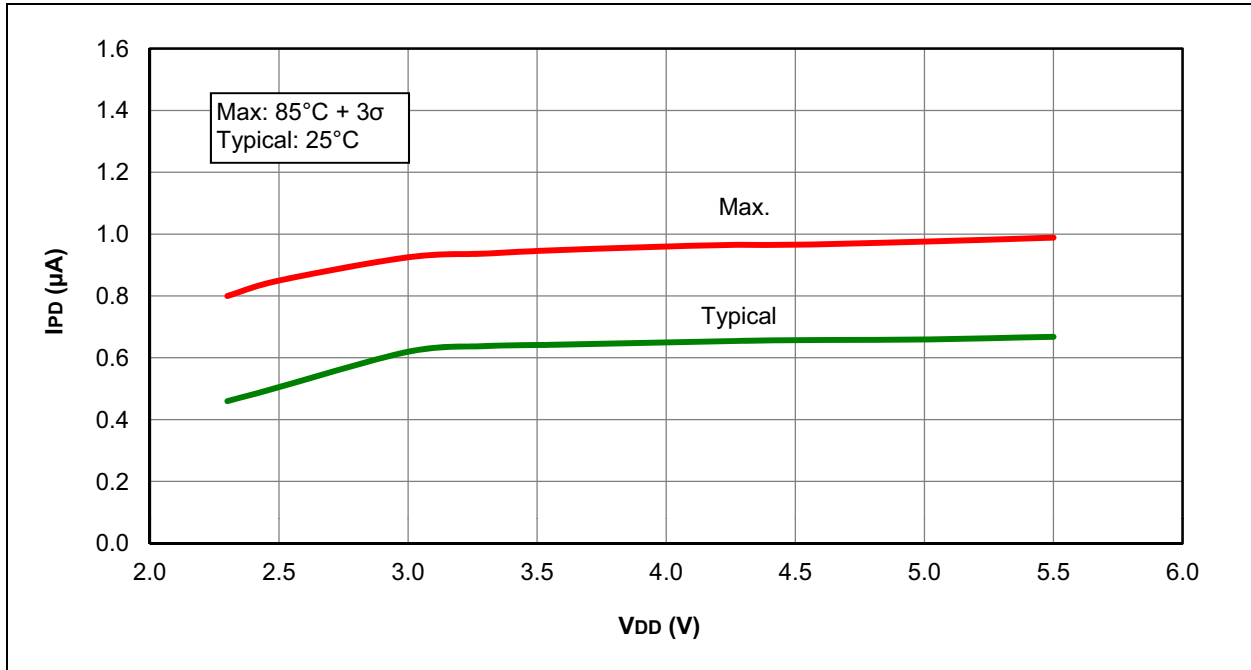

# PIC12(L)F1571/2

FIGURE 27-25: I<sub>PD</sub>, FIXED VOLTAGE REFERENCE (FVR), PIC12LF1571/2 ONLY

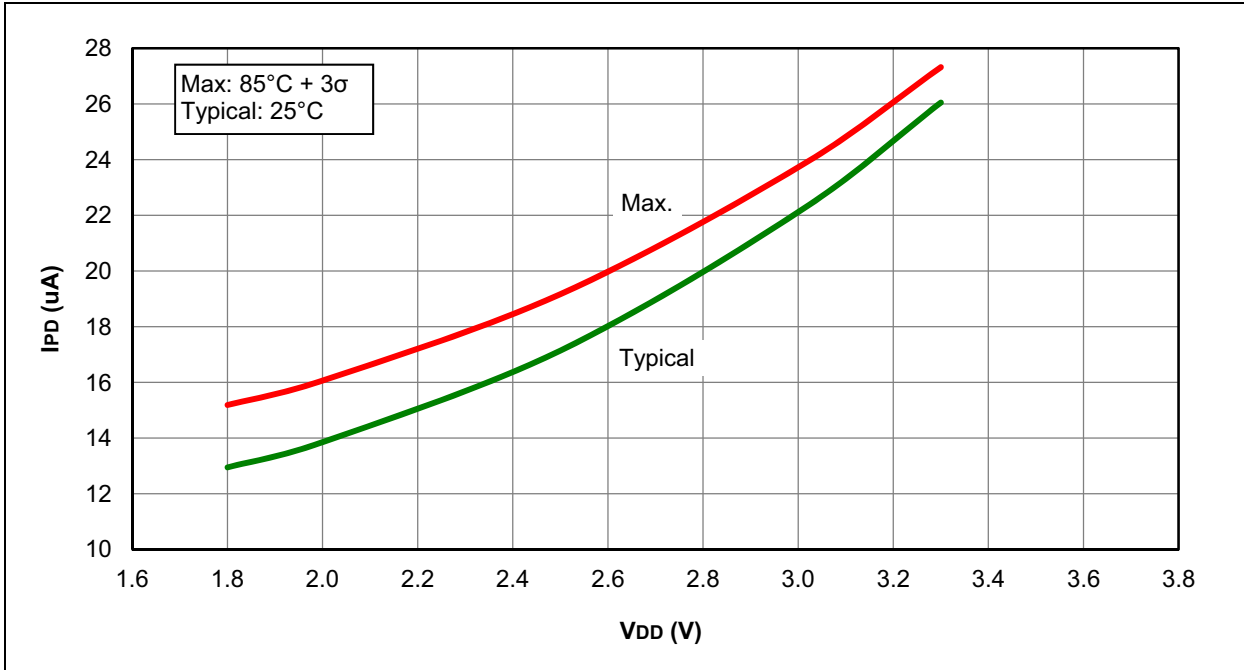
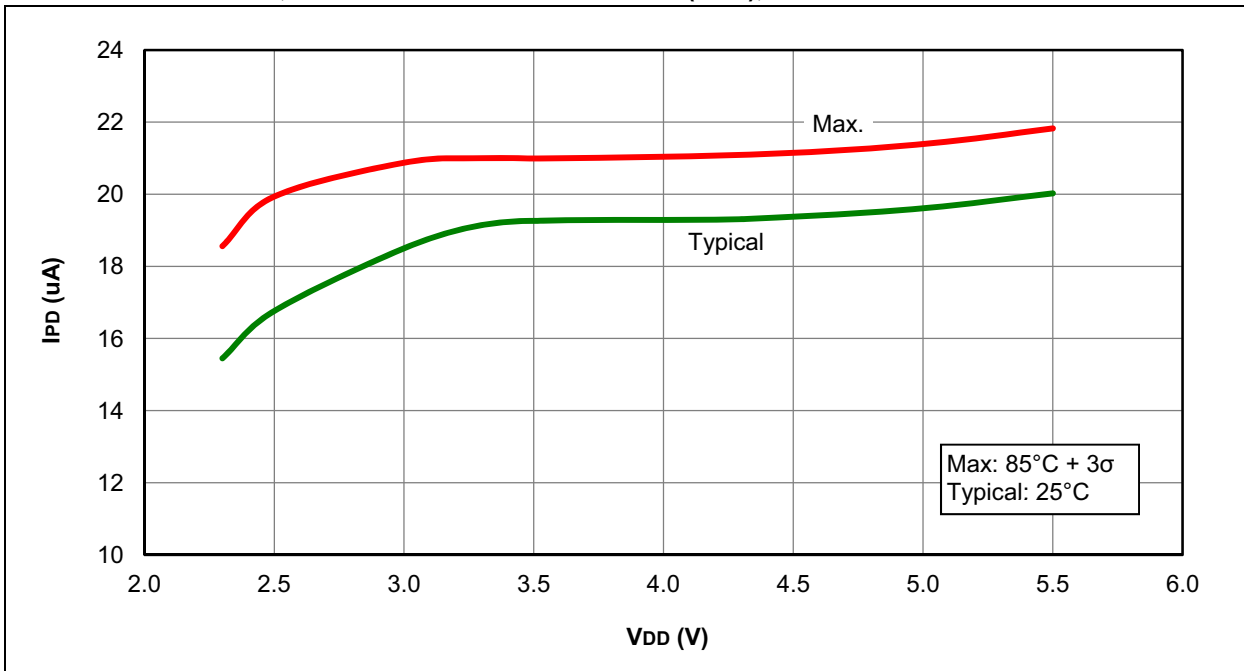
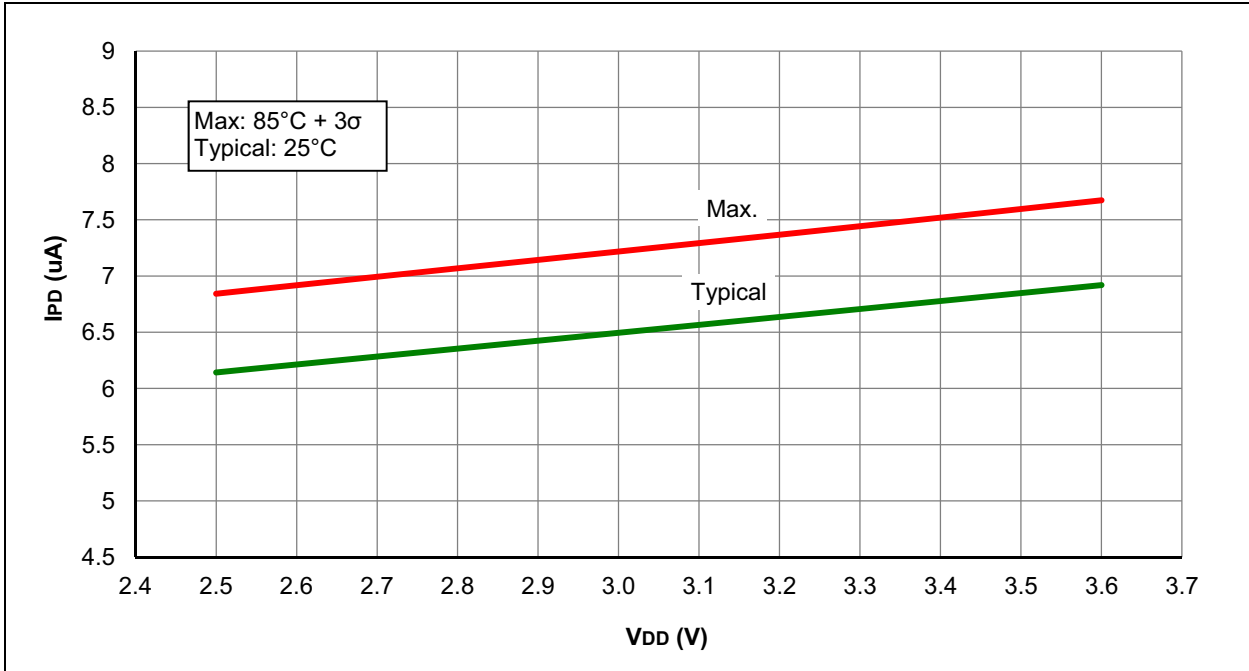

FIGURE 27-26: I<sub>PD</sub>, FIXED VOLTAGE REFERENCE (FVR), PIC12F1571/2 ONLY

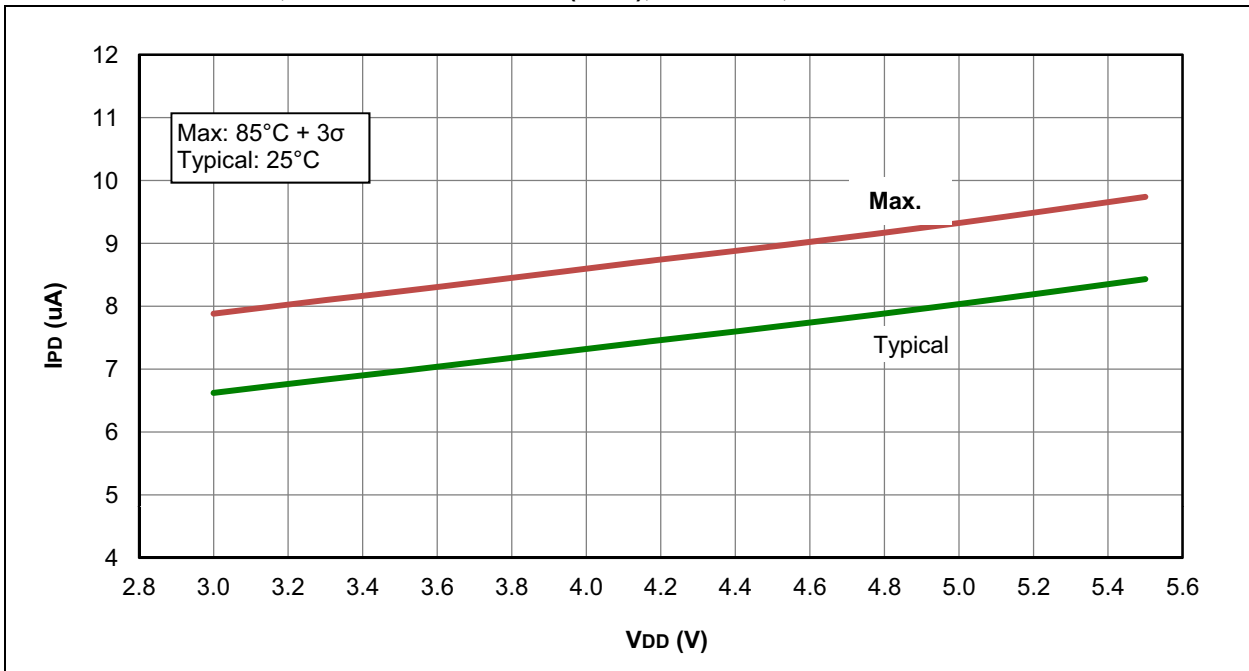



**FIGURE 27-27: I<sub>PD</sub>, BROWN-OUT RESET (BOR), BORV = 1, PIC12LF1571/2 ONLY**



**FIGURE 27-28: I<sub>PD</sub>, BROWN-OUT RESET (BOR), BORV = 1, PIC12F1571/2 ONLY**



# PIC12(L)F1571/2

FIGURE 27-29:  $I_{PD}$ , LOW-POWER BROWN-OUT RESET (LPBOR = 0), PIC12LF1571/2 ONLY

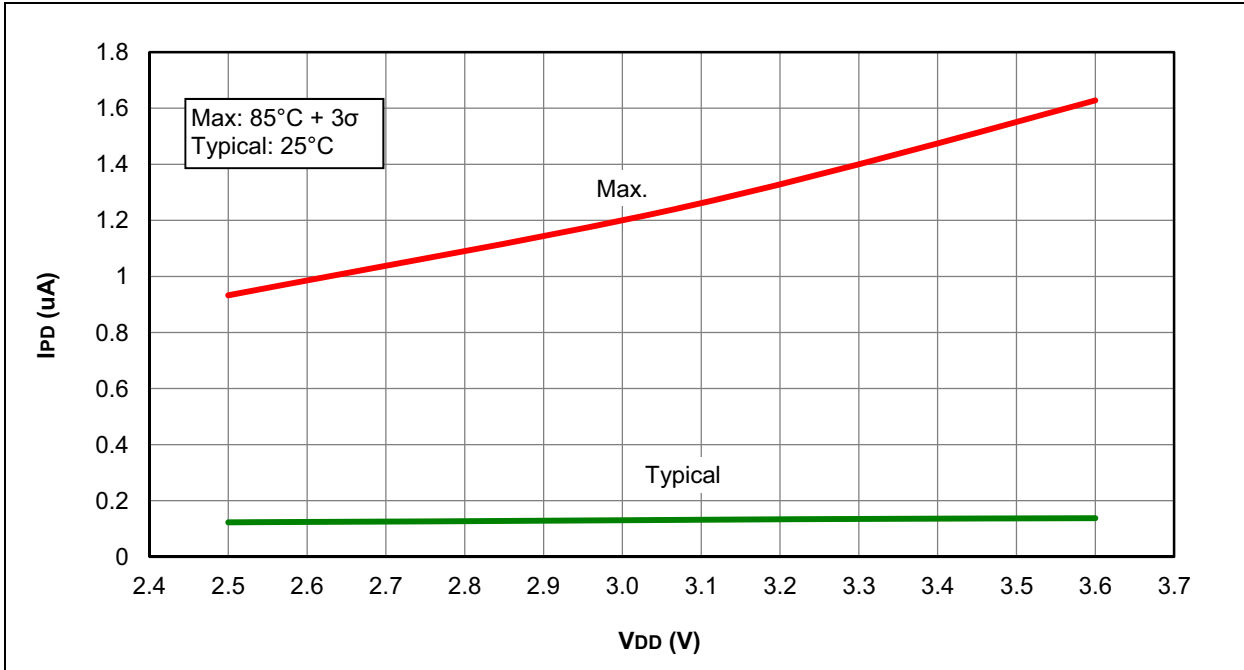
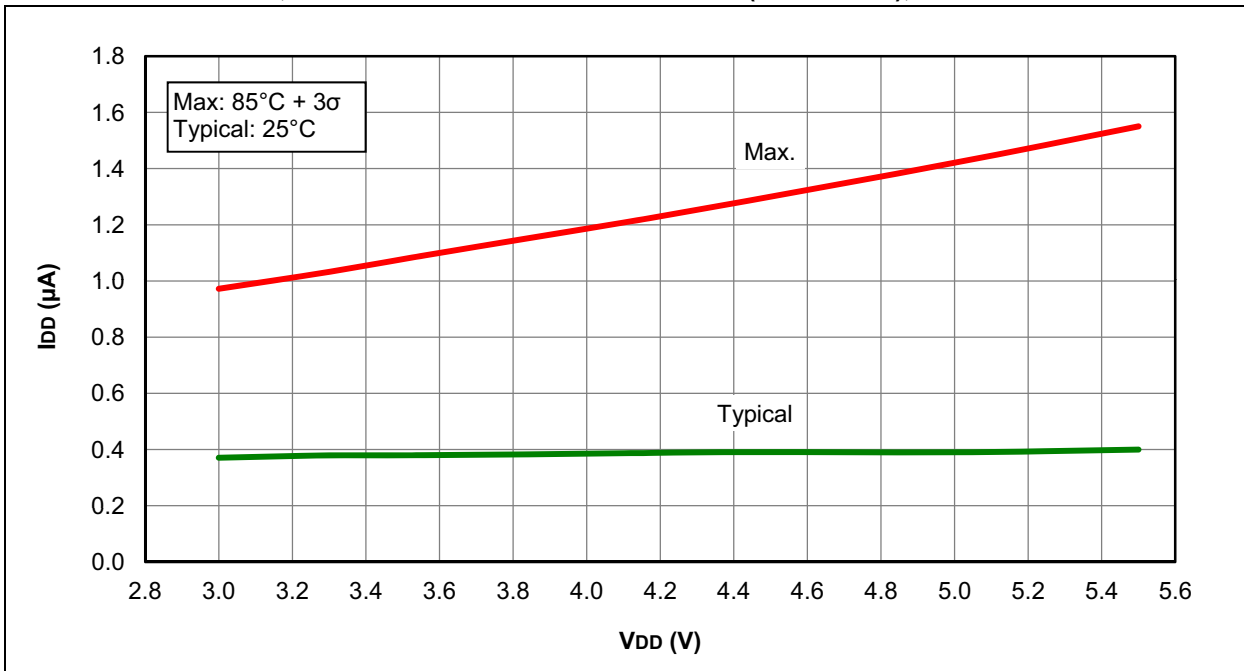
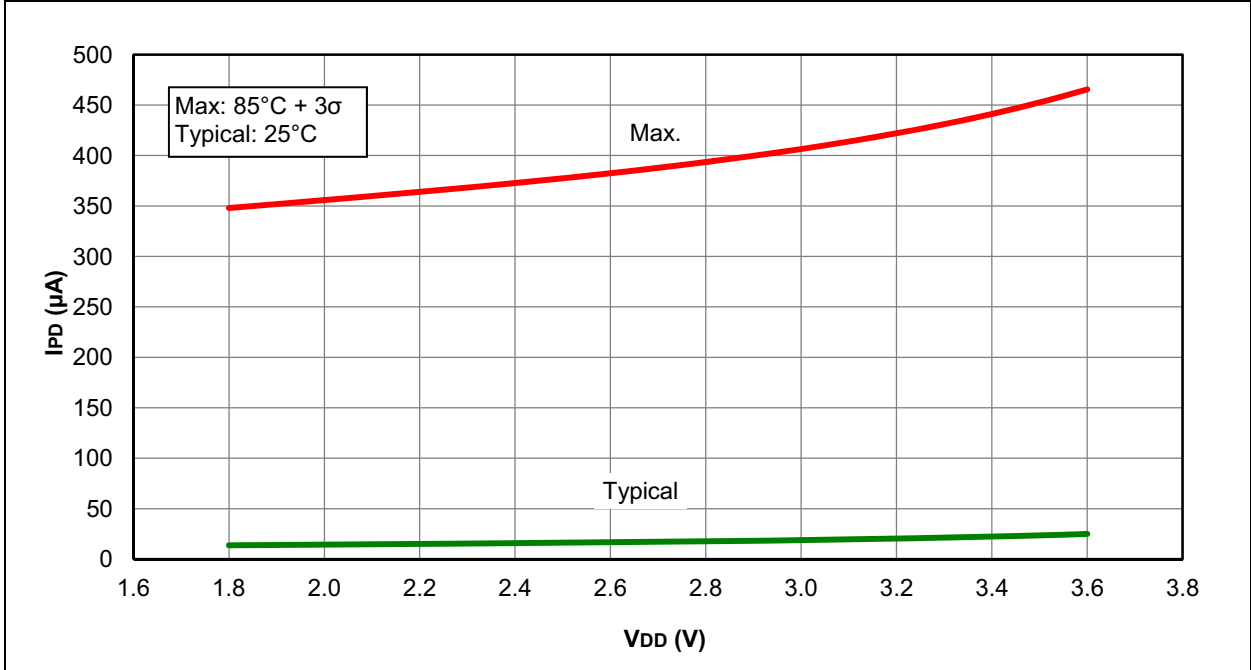

FIGURE 27-30:  $I_{DD}$ , LOW-POWER BROWN-OUT RESET (LPBOR = 0), PIC12F1571/2 ONLY



**FIGURE 27-31: I<sub>PD</sub>, ADC NON-CONVERTING, PIC12LF1571/2 ONLY**



**FIGURE 27-32: I<sub>DD</sub>, ADC NON-CONVERTING, PIC12F1571/2 ONLY**

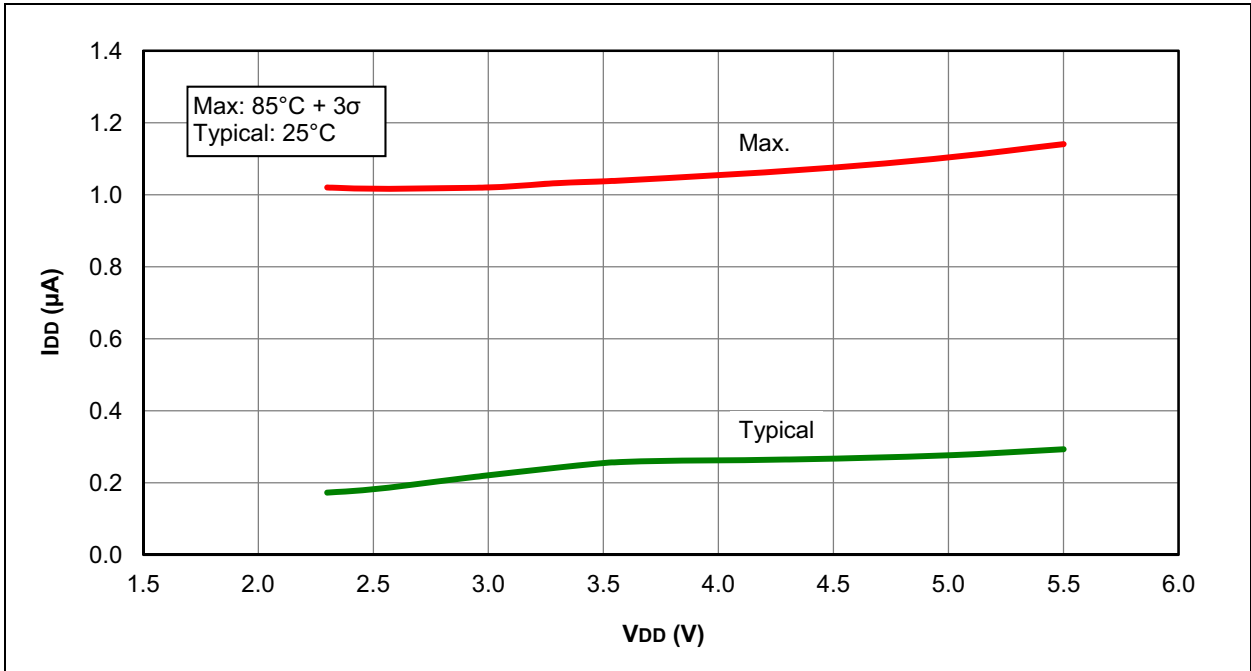

# PIC12(L)F1571/2

FIGURE 27-33: I<sub>PD</sub>, COMPARATOR, LOW-POWER MODE (C<sub>x</sub>SP = 0), PIC12F1571/2 ONLY

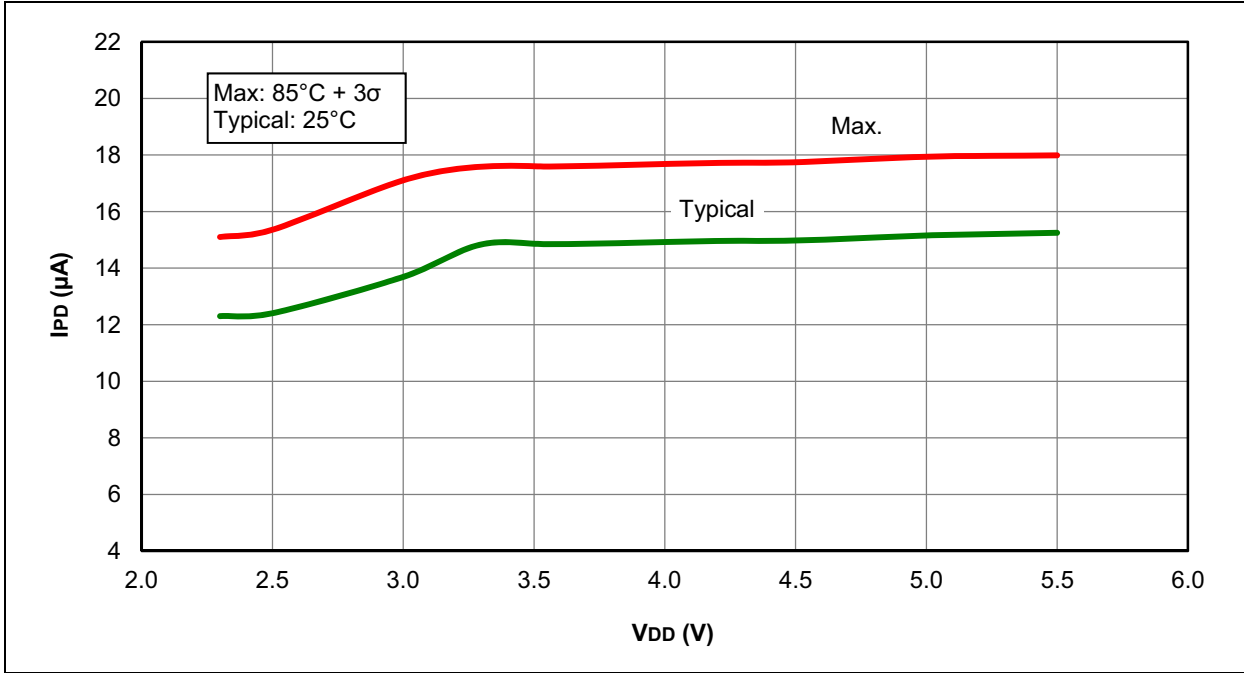

FIGURE 27-34: I<sub>PD</sub>, COMPARATOR, NORMAL POWER MODE (C<sub>x</sub>SP = 1), PIC12LF1571/2 ONLY

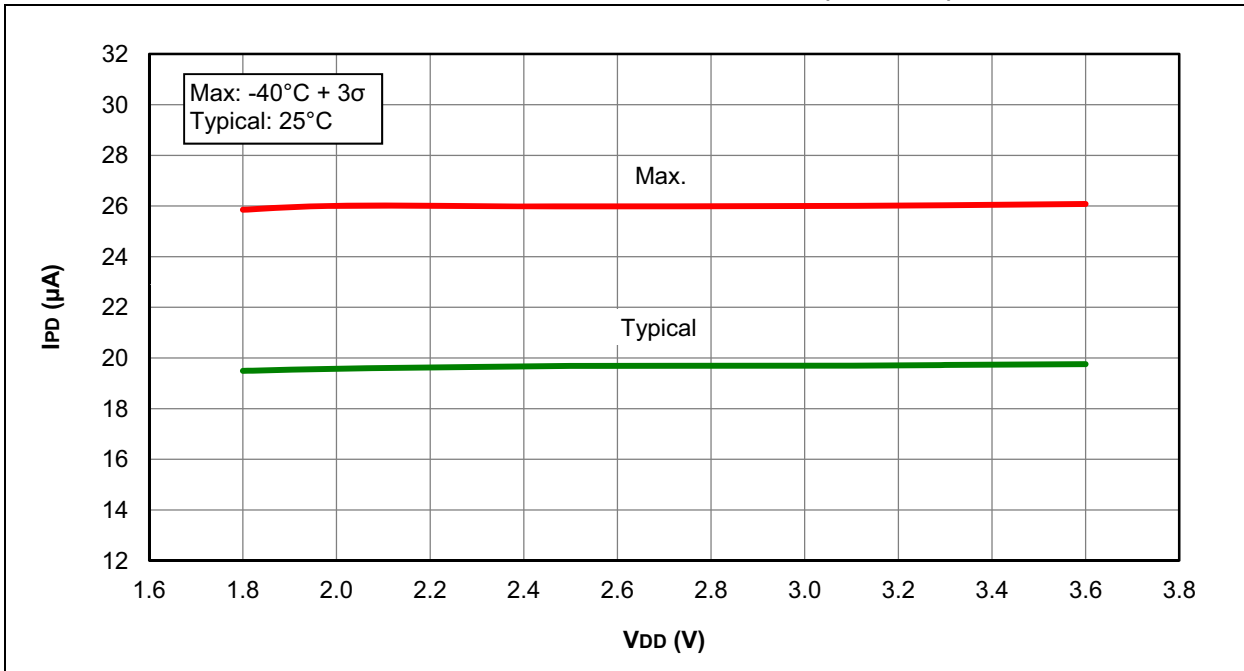
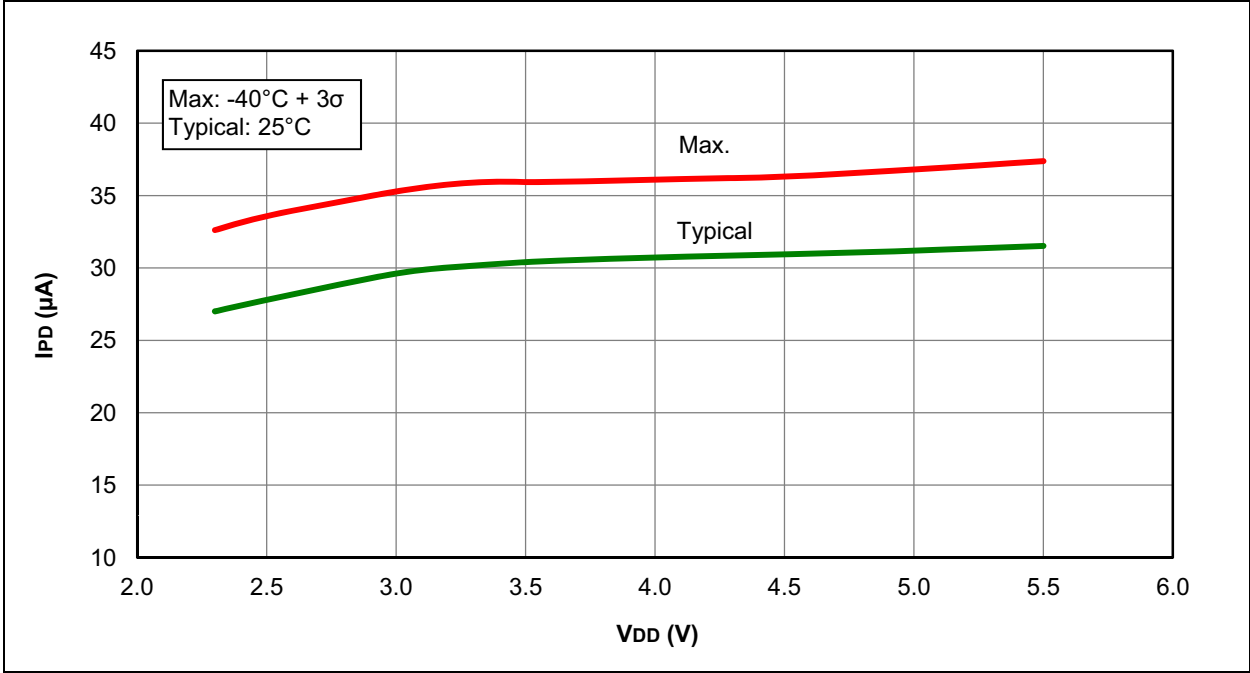
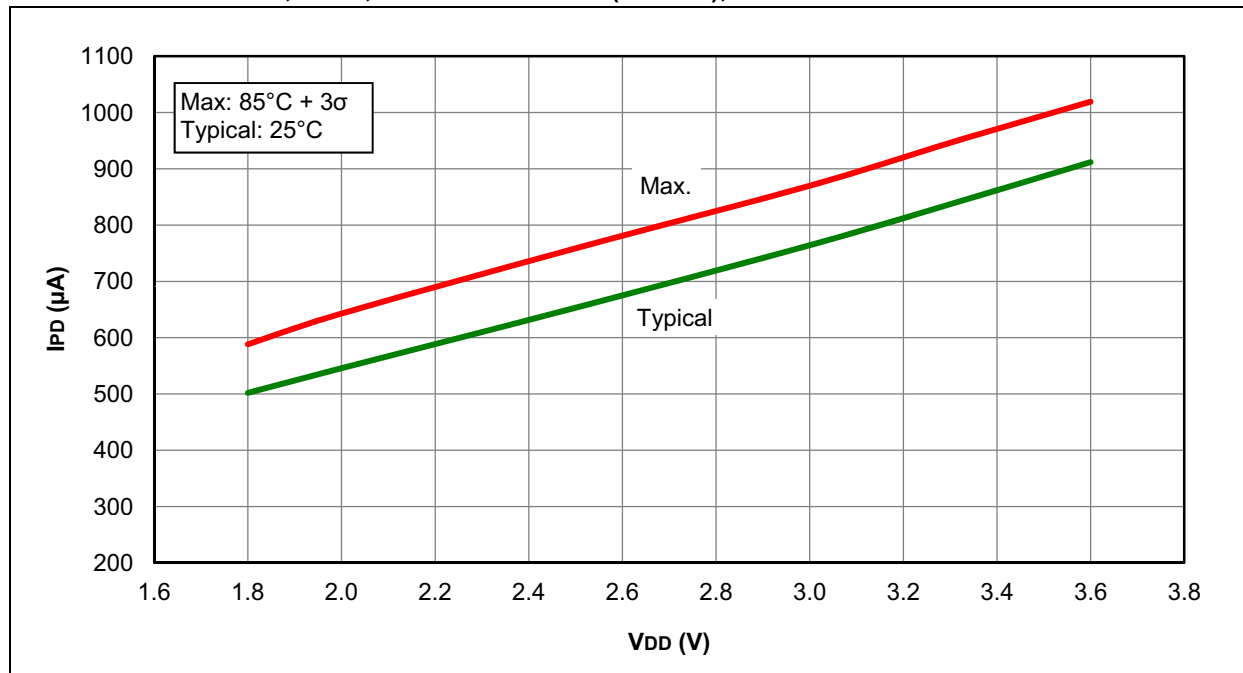

FIGURE 27-35: IPD, COMPARATOR, NORMAL POWER MODE (CxSP = 1), PIC12F1571/2 ONLY



# PIC12(L)F1571/2

**FIGURE 27-36: IPD, PWM, HFINTOSC MODE (16 MHz), PIC12LF1571/2 ONLY**



**FIGURE 27-37: IPD, PWM, HFINTOSC MODE (16 MHz), PIC12F1571/2 ONLY**

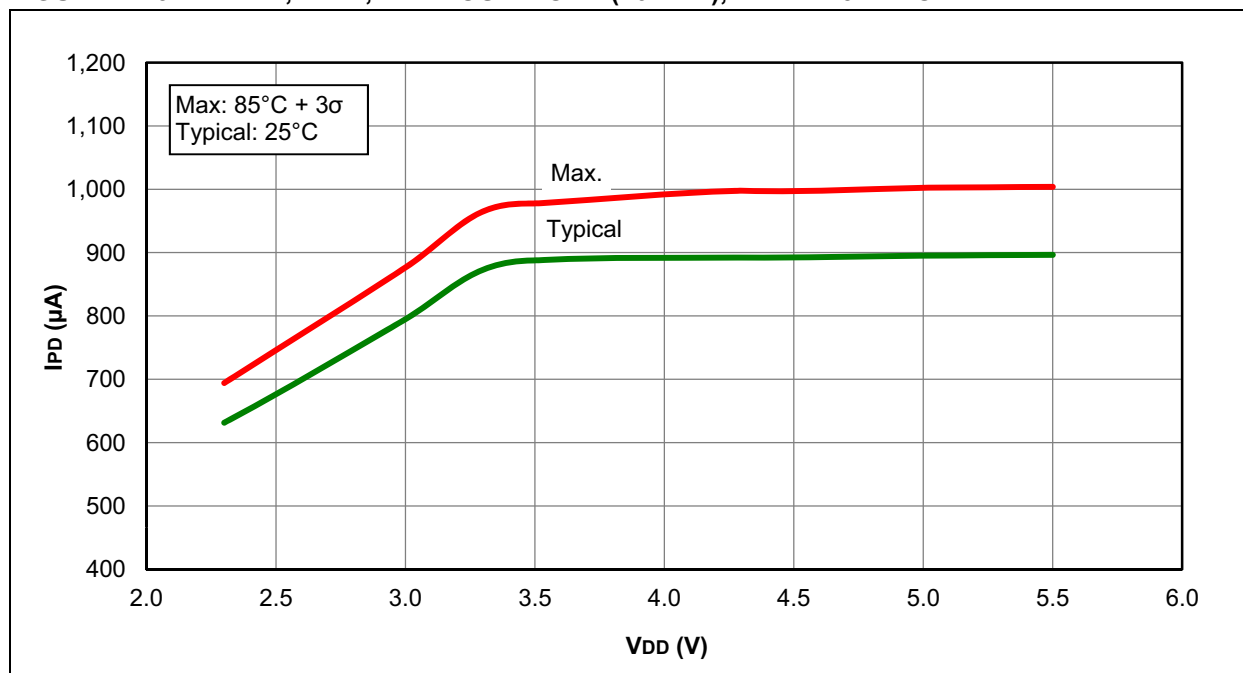
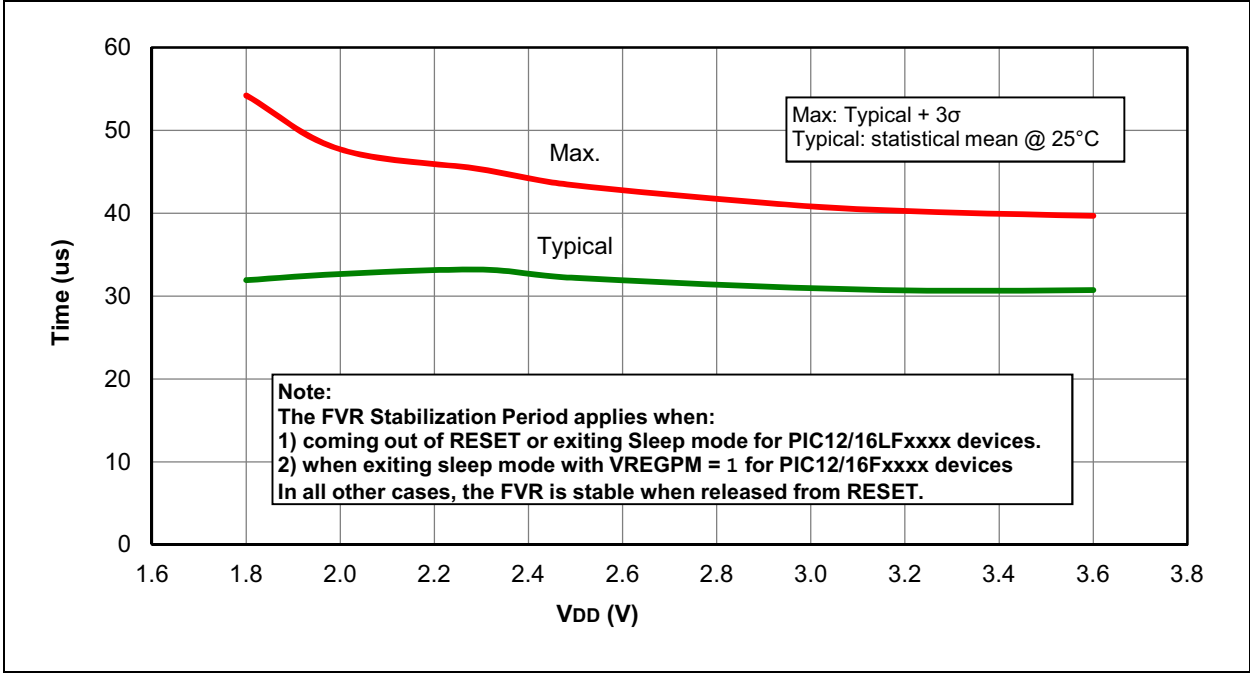

FIGURE 27-38: FVR STABILIZATION PERIOD



# PIC12(L)F1571/2

---

NOTES:



## 28.0 DEVELOPMENT SUPPORT

The PIC® microcontrollers (MCU) and dsPIC® digital signal controllers (DSC) are supported with a full range of software and hardware development tools:

- Integrated Development Environment
  - MPLAB® X IDE Software
- Compilers/Assemblers/Linkers
  - MPLAB XC Compiler
  - MPASM™ Assembler
  - MPLINK™ Object Linker/  
MPLIB™ Object Librarian
  - MPLAB Assembler/Linker/Librarian for  
Various Device Families
- Simulators
  - MPLAB X SIM Software Simulator
- Emulators
  - MPLAB REAL ICE™ In-Circuit Emulator
- In-Circuit Debuggers/Programmers
  - MPLAB ICD 3
  - PICKit™ 3
- Device Programmers
  - MPLAB PM3 Device Programmer
- Low-Cost Demonstration/Development Boards,  
Evaluation Kits and Starter Kits
- Third-party development tools

## 28.1 MPLAB X Integrated Development Environment Software

The MPLAB X IDE is a single, unified graphical user interface for Microchip and third-party software, and hardware development tool that runs on Windows®, Linux and Mac OS® X. Based on the NetBeans IDE, MPLAB X IDE is an entirely new IDE with a host of free software components and plug-ins for high-performance application development and debugging. Moving between tools and upgrading from software simulators to hardware debugging and programming tools is simple with the seamless user interface.

With complete project management, visual call graphs, a configurable watch window and a feature-rich editor that includes code completion and context menus, MPLAB X IDE is flexible and friendly enough for new users. With the ability to support multiple tools on multiple projects with simultaneous debugging, MPLAB X IDE is also suitable for the needs of experienced users.

Feature-Rich Editor:

- Color syntax highlighting
- Smart code completion makes suggestions and provides hints as you type
- Automatic code formatting based on user-defined rules
- Live parsing

User-Friendly, Customizable Interface:

- Fully customizable interface: toolbars, toolbar buttons, windows, window placement, etc.
- Call graph window

Project-Based Workspaces:

- Multiple projects
- Multiple tools
- Multiple configurations
- Simultaneous debugging sessions

File History and Bug Tracking:

- Local file history feature
- Built-in support for Bugzilla issue tracker

## 28.2 MPLAB XC Compilers

The MPLAB XC Compilers are complete ANSI C compilers for all of Microchip's 8, 16, and 32-bit MCU and DSC devices. These compilers provide powerful integration capabilities, superior code optimization and ease of use. MPLAB XC Compilers run on Windows, Linux or MAC OS X.

For easy source level debugging, the compilers provide debug information that is optimized to the MPLAB X IDE.

The free MPLAB XC Compiler editions support all devices and commands, with no time or memory restrictions, and offer sufficient code optimization for most applications.

MPLAB XC Compilers include an assembler, linker and utilities. The assembler generates relocatable object files that can then be archived or linked with other relocatable object files and archives to create an executable file. MPLAB XC Compiler uses the assembler to produce its object file. Notable features of the assembler include:

- Support for the entire device instruction set
- Support for fixed-point and floating-point data
- Command-line interface
- Rich directive set
- Flexible macro language
- MPLAB X IDE compatibility

## 28.3 MPASM Assembler

The MPASM Assembler is a full-featured, universal macro assembler for PIC10/12/16/18 MCUs.

The MPASM Assembler generates relocatable object files for the MPLINK Object Linker, Intel® standard HEX files, MAP files to detail memory usage and symbol reference, absolute LST files that contain source lines and generated machine code, and COFF files for debugging.

The MPASM Assembler features include:

- Integration into MPLAB X IDE projects
- User-defined macros to streamline assembly code
- Conditional assembly for multipurpose source files
- Directives that allow complete control over the assembly process

## 28.4 MPLINK Object Linker/ MPLIB Object Librarian

The MPLINK Object Linker combines relocatable objects created by the MPASM Assembler. It can link relocatable objects from precompiled libraries, using directives from a linker script.

The MPLIB Object Librarian manages the creation and modification of library files of precompiled code. When a routine from a library is called from a source file, only the modules that contain that routine will be linked in with the application. This allows large libraries to be used efficiently in many different applications.

The object linker/library features include:

- Efficient linking of single libraries instead of many smaller files
- Enhanced code maintainability by grouping related modules together
- Flexible creation of libraries with easy module listing, replacement, deletion and extraction

## 28.5 MPLAB Assembler, Linker and Librarian for Various Device Families

MPLAB Assembler produces relocatable machine code from symbolic assembly language for PIC24, PIC32 and dsPIC DSC devices. MPLAB XC Compiler uses the assembler to produce its object file. The assembler generates relocatable object files that can then be archived or linked with other relocatable object files and archives to create an executable file. Notable features of the assembler include:

- Support for the entire device instruction set
- Support for fixed-point and floating-point data
- Command-line interface
- Rich directive set
- Flexible macro language
- MPLAB X IDE compatibility

## 28.6 MPLAB X SIM Software Simulator

The MPLAB X SIM Software Simulator allows code development in a PC-hosted environment by simulating the PIC MCUs and dsPIC DSCs on an instruction level. On any given instruction, the data areas can be examined or modified and stimuli can be applied from a comprehensive stimulus controller. Registers can be logged to files for further run-time analysis. The trace buffer and logic analyzer display extend the power of the simulator to record and track program execution, actions on I/O, most peripherals and internal registers.

The MPLAB X SIM Software Simulator fully supports symbolic debugging using the MPLAB XC Compilers, and the MPASM and MPLAB Assemblers. The software simulator offers the flexibility to develop and debug code outside of the hardware laboratory environment, making it an excellent, economical software development tool.

## 28.7 MPLAB REAL ICE In-Circuit Emulator System

The MPLAB REAL ICE In-Circuit Emulator System is Microchip's next generation high-speed emulator for Microchip Flash DSC and MCU devices. It debugs and programs all 8, 16 and 32-bit MCU, and DSC devices with the easy-to-use, powerful graphical user interface of the MPLAB X IDE.

The emulator is connected to the design engineer's PC using a high-speed USB 2.0 interface and is connected to the target with either a connector compatible with in-circuit debugger systems (RJ-11) or with the new high-speed, noise tolerant, Low-Voltage Differential Signal (LVDS) interconnection (CAT5).

The emulator is field upgradable through future firmware downloads in MPLAB X IDE. MPLAB REAL ICE offers significant advantages over competitive emulators including full-speed emulation, run-time variable watches, trace analysis, complex breakpoints, logic probes, a ruggedized probe interface and long (up to three meters) interconnection cables.

## 28.8 MPLAB ICD 3 In-Circuit Debugger System

The MPLAB ICD 3 In-Circuit Debugger System is Microchip's most cost-effective, high-speed hardware debugger/programmer for Microchip Flash DSC and MCU devices. It debugs and programs PIC Flash microcontrollers and dsPIC DSCs with the powerful, yet easy-to-use graphical user interface of the MPLAB IDE.

The MPLAB ICD 3 In-Circuit Debugger probe is connected to the design engineer's PC using a high-speed USB 2.0 interface and is connected to the target with a connector compatible with the MPLAB ICD 2 or MPLAB REAL ICE systems (RJ-11). MPLAB ICD 3 supports all MPLAB ICD 2 headers.

## 28.9 PICkit 3 In-Circuit Debugger/Programmer

The MPLAB PICkit 3 allows debugging and programming of PIC and dsPIC Flash microcontrollers at a most affordable price point using the powerful graphical user interface of the MPLAB IDE. The MPLAB PICkit 3 is connected to the design engineer's PC using a full-speed USB interface and can be connected to the target via a Microchip debug (RJ-11) connector (compatible with MPLAB ICD 3 and MPLAB REAL ICE). The connector uses two device I/O pins and the Reset line to implement in-circuit debugging and In-Circuit Serial Programming™ (ICSP™).

## 28.10 MPLAB PM3 Device Programmer

The MPLAB PM3 Device Programmer is a universal, CE compliant device programmer with programmable voltage verification at VDDMIN and VDDMAX for maximum reliability. It features a large LCD display (128 x 64) for menus and error messages, and a modular, detachable socket assembly to support various package types. The ICSP cable assembly is included as a standard item. In Stand-Alone mode, the MPLAB PM3 Device Programmer can read, verify and program PIC devices without a PC connection. It can also set code protection in this mode. The MPLAB PM3 connects to the host PC via an RS-232 or USB cable. The MPLAB PM3 has high-speed communications and optimized algorithms for quick programming of large memory devices, and incorporates an MMC card for file storage and data applications.

## 28.11 Demonstration/Development Boards, Evaluation Kits, and Starter Kits

A wide variety of demonstration, development and evaluation boards for various PIC MCUs and dsPIC DSCs allows quick application development on fully functional systems. Most boards include prototyping areas for adding custom circuitry and provide application firmware and source code for examination and modification.

The boards support a variety of features, including LEDs, temperature sensors, switches, speakers, RS-232 interfaces, LCD displays, potentiometers and additional EEPROM memory.

The demonstration and development boards can be used in teaching environments, for prototyping custom circuits and for learning about various microcontroller applications.

In addition to the PICDEM™ and dsPICDEM™ demonstration/development board series of circuits, Microchip has a line of evaluation kits and demonstration software for analog filter design, KEELOQ® security ICs, CAN, IrDA®, PowerSmart battery management, SEEVAL® evaluation system, Sigma-Delta ADC, flow rate sensing, plus many more.

Also available are starter kits that contain everything needed to experience the specified device. This usually includes a single application and debug capability, all on one board.

Check the Microchip web page ([www.microchip.com](http://www.microchip.com)) for the complete list of demonstration, development and evaluation kits.

## 28.12 Third-Party Development Tools

Microchip also offers a great collection of tools from third-party vendors. These tools are carefully selected to offer good value and unique functionality.

- Device Programmers and Gang Programmers from companies, such as SoftLog and CCS
- Software Tools from companies, such as Gimpel and Trace Systems
- Protocol Analyzers from companies, such as Saleae and Total Phase
- Demonstration Boards from companies, such as MikroElektronika, Digilent® and Olimex
- Embedded Ethernet Solutions from companies, such as EZ Web Lynx, WIZnet and IPLogika®

## 29.0 PACKAGING INFORMATION

### 29.1 Package Marking Information

8-Lead PDIP (300 mil)

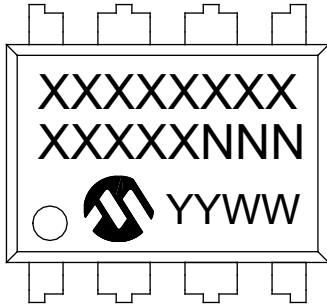

Example

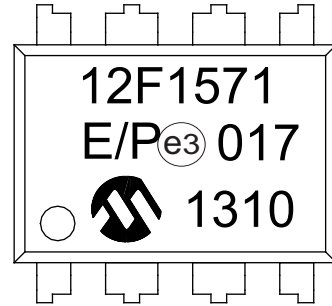

8-Lead SOIC (3.90 mm)

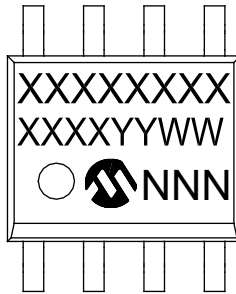

Example

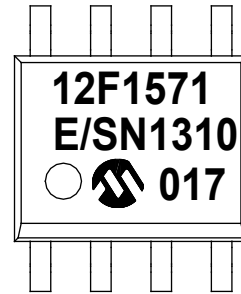

<b>Legend:</b>	XX...X	Customer-specific information
	Y	Year code (last digit of calendar year)
	YY	Year code (last 2 digits of calendar year)
	WW	Week code (week of January 1 is week '01')
	NNN	Alphanumeric traceability code
	ⓔ3	Pb-free JEDEC® designator for Matte Tin (Sn)
	*	This package is Pb-free. The Pb-free JEDEC designator (ⓔ3) can be found on the outer packaging for this package.
<b>Note:</b>	In the event the full Microchip part number cannot be marked on one line, it will be carried over to the next line, thus limiting the number of available characters for customer-specific information.	

# PIC12(L)F1571/2

---

## Package Marking Information (Continued)

8-Lead MSOP (3x3 mm)

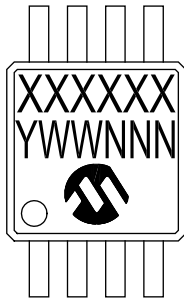

Example

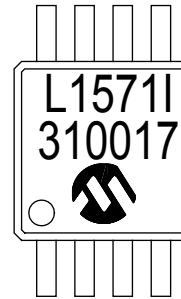

8-Lead DFN (3x3x0.9 mm)  
8-Lead UDFN (3x3x0.5 mm)

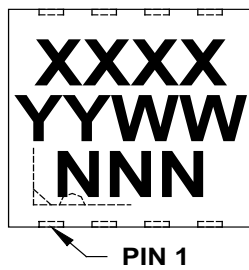

Example

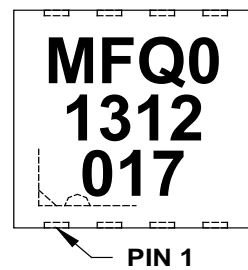

**TABLE 29-1: 8-LEAD 3x3x0.9 DFN (MF) TOP MARKING**

Part Number	Marking
PIC12F1571-E/MF	MFY0/YYWW/NNN
PIC12F1572-E/MF	MGA0/YYWW/NNN
PIC12F1571-I/MF	MFZ0
PIC12F1572-I/MF	MGB0
PIC12LF1571-E/MF	MGC0
PIC12LF1572-E/MF	MGE0
PIC12LF1571-I/MF	MGD0
PIC12LF1572-I/MF	MGF0

**TABLE 29-2: 8-LEAD 3x3x0.5 UDFN (RF) TOP MARKING**

Part Number	Marking
PIC12F1571-E/MF	MFY0/YYWW/NNN
PIC12F1572-E/MF	MGA0/YYWW/NNN
PIC12F1571-I/MF	MFZ0
PIC12F1572-I/MF	MGB0
PIC12LF1571-E/MF	MGC0
PIC12LF1572-E/MF	MGE0
PIC12LF1571-I/MF	MGD0
PIC12LF1572-I/MF	MGF0

# PIC12(L)F1571/2

## 29.2 Package Details

The following sections give the technical details of the packages.

### 8-Lead Plastic Dual In-Line (P) - 300 mil Body [PDIP]

**Note:** For the most current package drawings, please see the Microchip Packaging Specification located at <http://www.microchip.com/packaging>

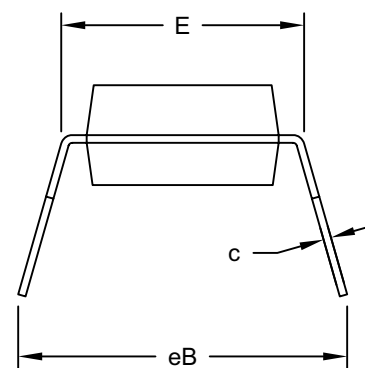
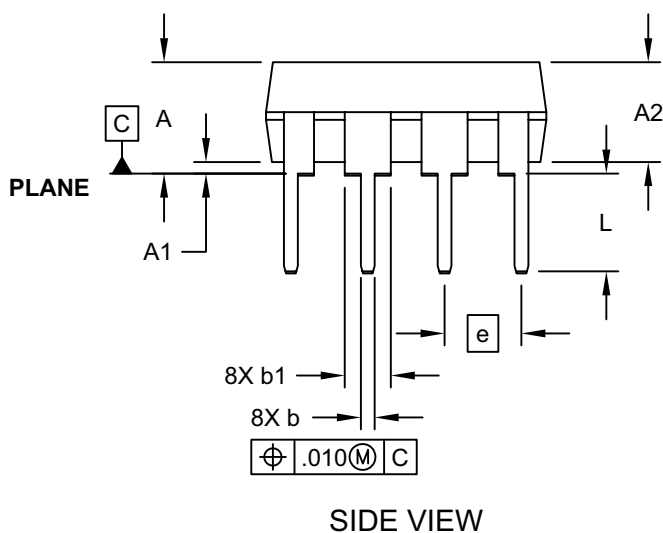
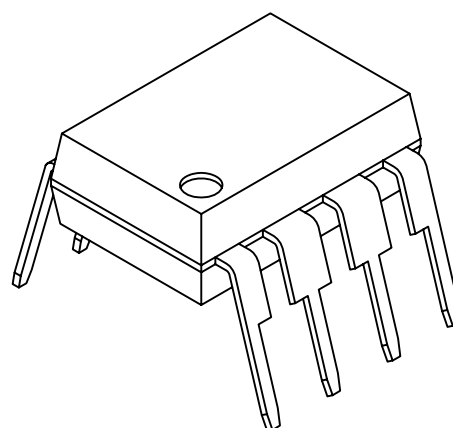
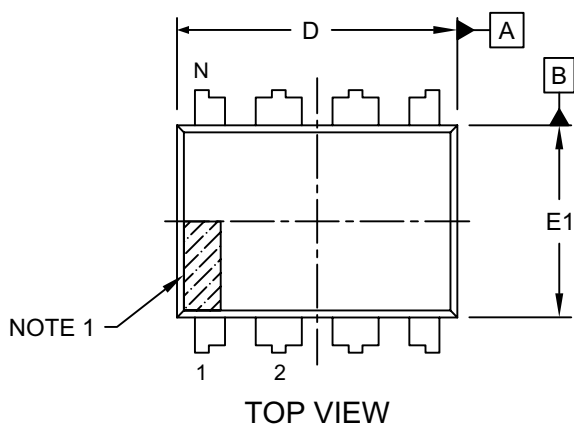

Microchip Technology Drawing No. C04-018D Sheet 1 of 2



## 8-Lead Plastic Dual In-Line (P) - 300 mil Body [PDIP]

**Note:** For the most current package drawings, please see the Microchip Packaging Specification located at <http://www.microchip.com/packaging>

### ALTERNATE LEAD DESIGN (VENDOR DEPENDENT)

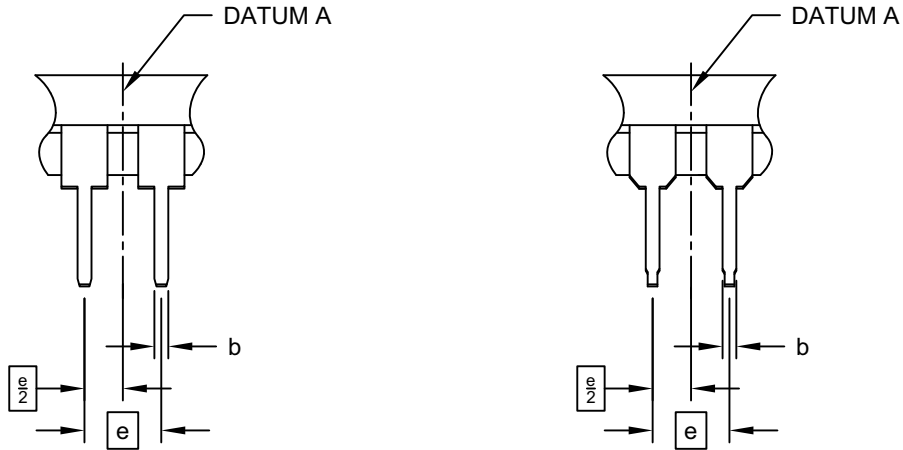

		Units	INCHES		
Dimension Limits			MIN	NOM	MAX
Number of Pins	N		8		
Pitch	e		.100 BSC		
Top to Seating Plane	A	-	-	-	.210
Molded Package Thickness	A2	.115	.130	.195	
Base to Seating Plane	A1	.015	-	-	
Shoulder to Shoulder Width	E	.290	.310	.325	
Molded Package Width	E1	.240	.250	.280	
Overall Length	D	.348	.365	.400	
Tip to Seating Plane	L	.115	.130	.150	
Lead Thickness	c	.008	.010	.015	
Upper Lead Width	b1	.040	.060	.070	
Lower Lead Width	b	.014	.018	.022	
Overall Row Spacing	§	eB	-	-	.430

**Notes:**

1. Pin 1 visual index feature may vary, but must be located within the hatched area.
2. § Significant Characteristic
3. Dimensions D and E1 do not include mold flash or protrusions. Mold flash or protrusions shall not exceed .010" per side.
4. Dimensioning and tolerancing per ASME Y14.5M

BSC: Basic Dimension. Theoretically exact value shown without tolerances.

Microchip Technology Drawing No. C04-018D Sheet 2 of 2



## 8-Lead Plastic Small Outline (SN) - Narrow, 3.90 mm Body [SOIC]

**Note:** For the most current package drawings, please see the Microchip Packaging Specification located at <http://www.microchip.com/packaging>

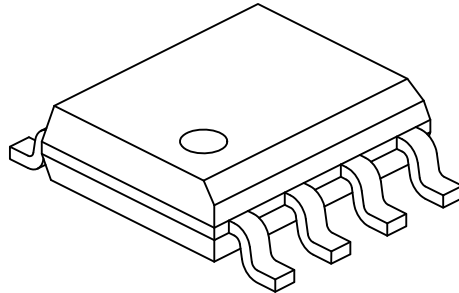

Dimension Limits	Units	MILLIMETERS		
		MIN	NOM	MAX
Number of Pins	N	8		
Pitch	e	1.27 BSC		
Overall Height	A	-	-	1.75
Molded Package Thickness	A2	1.25	-	-
Standoff §	A1	0.10	-	0.25
Overall Width	E	6.00 BSC		
Molded Package Width	E1	3.90 BSC		
Overall Length	D	4.90 BSC		
Chamfer (Optional)	h	0.25	-	0.50
Foot Length	L	0.40	-	1.27
Footprint	L1	1.04 REF		
Foot Angle	$\varphi$	0°	-	8°
Lead Thickness	c	0.17	-	0.25
Lead Width	b	0.31	-	0.51
Mold Draft Angle Top	$\alpha$	5°	-	15°
Mold Draft Angle Bottom	$\beta$	5°	-	15°

**Notes:**

1. Pin 1 visual index feature may vary, but must be located within the hatched area.
2. § Significant Characteristic
3. Dimensions D and E1 do not include mold flash or protrusions. Mold flash or protrusions shall not exceed 0.15mm per side.
4. Dimensioning and tolerancing per ASME Y14.5M

BSC: Basic Dimension. Theoretically exact value shown without tolerances.

REF: Reference Dimension, usually without tolerance, for information purposes only.

Microchip Technology Drawing No. C04-057C Sheet 2 of 2

# PIC12(L)F1571/2

## 8-Lead Plastic Small Outline (SN) – Narrow, 3.90 mm Body [SOIC]

**Note:** For the most current package drawings, please see the Microchip Packaging Specification located at <http://www.microchip.com/packaging>

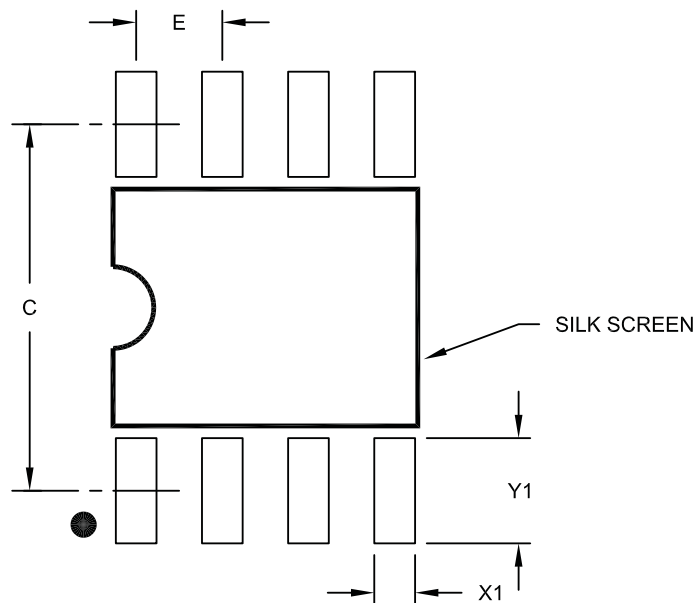

RECOMMENDED LAND PATTERN

Dimension Limits	Units	MILLIMETERS		
		MIN	NOM	MAX
Contact Pitch	E	1.27 BSC		
Contact Pad Spacing	C		5.40	
Contact Pad Width (X8)	X1			0.60
Contact Pad Length (X8)	Y1			1.55

**Notes:**

1. Dimensioning and tolerancing per ASME Y14.5M

BSC: Basic Dimension. Theoretically exact value shown without tolerances.

Microchip Technology Drawing No. C04-2057A

8-Lead Plastic Micro Small Outline Package (MS) [MSOP]

**Note:** For the most current package drawings, please see the Microchip Packaging Specification located at <http://www.microchip.com/packaging>

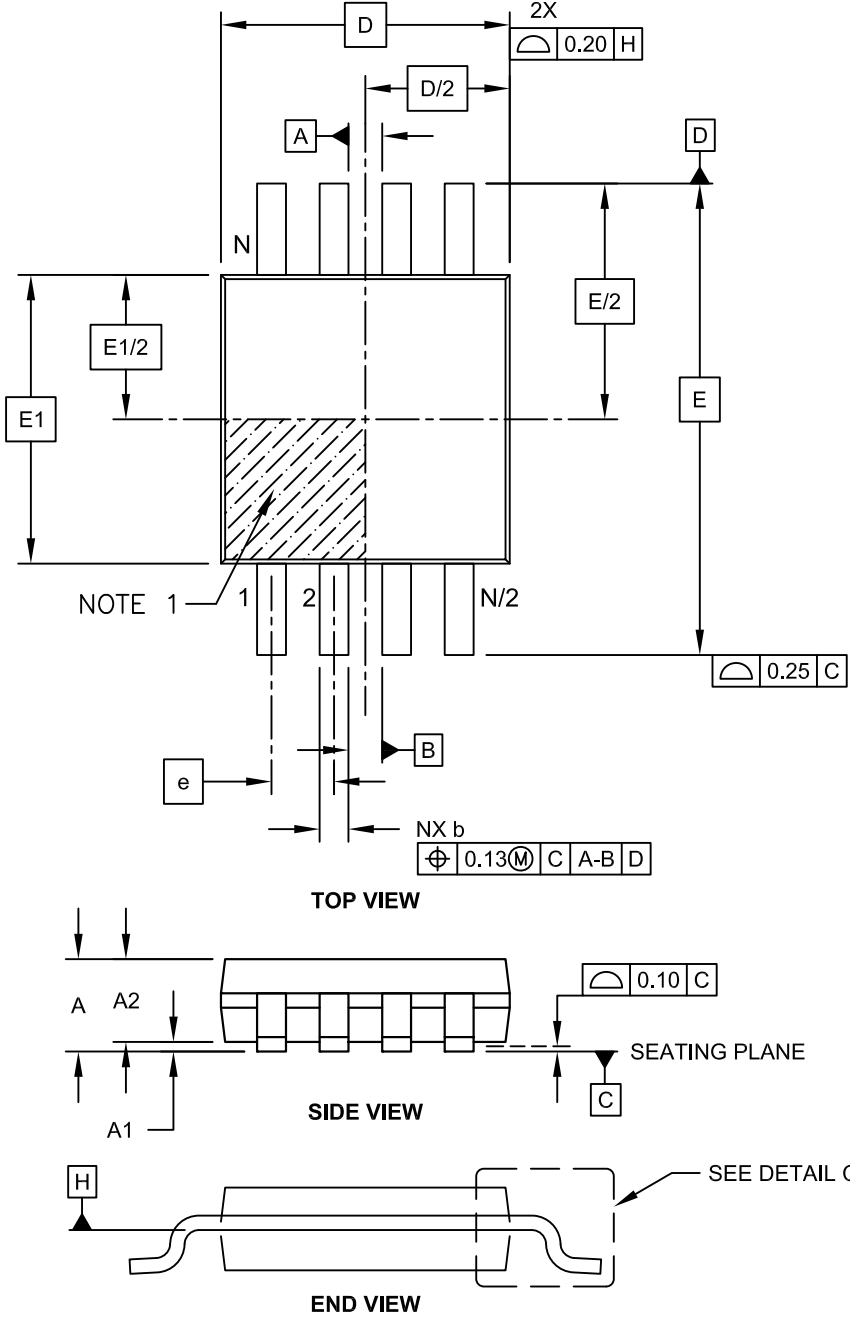

# PIC12(L)F1571/2

## 8-Lead Plastic Micro Small Outline Package (MS) [MSOP]

**Note:** For the most current package drawings, please see the Microchip Packaging Specification located at <http://www.microchip.com/packaging>

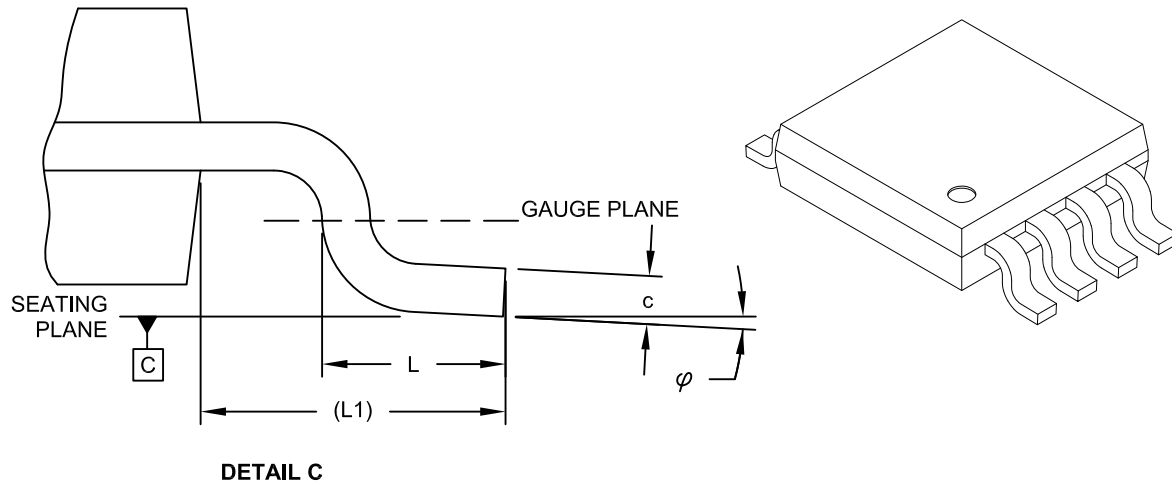

Dimension Limits	Units	MILLIMETERS		
		MIN	NOM	MAX
Number of Pins	N		8	
Pitch	e	0.65 BSC		
Overall Height	A	-	-	1.10
Molded Package Thickness	A2	0.75	0.85	0.95
Standoff	A1	0.00	-	0.15
Overall Width	E	4.90 BSC		
Molded Package Width	E1	3.00 BSC		
Overall Length	D	3.00 BSC		
Foot Length	L	0.40	0.60	0.80
Footprint	L1	0.95 REF		
Foot Angle	φ	0°	-	8°
Lead Thickness	c	0.08	-	0.23
Lead Width	b	0.22	-	0.40

**Notes:**

- Pin 1 visual index feature may vary, but must be located within the hatched area.
- Dimensions D and E1 do not include mold flash or protrusions. Mold flash or protrusions shall not exceed 0.15mm per side.
- Dimensioning and tolerancing per ASME Y14.5M.  
 BSC: Basic Dimension. Theoretically exact value shown without tolerances.  
 REF: Reference Dimension, usually without tolerance, for information purposes only.

Microchip Technology Drawing C04-111C Sheet 2 of 2

## 8-Lead Plastic Micro Small Outline Package (MS) [MSOP]

**Note:** For the most current package drawings, please see the Microchip Packaging Specification located at <http://www.microchip.com/packaging>

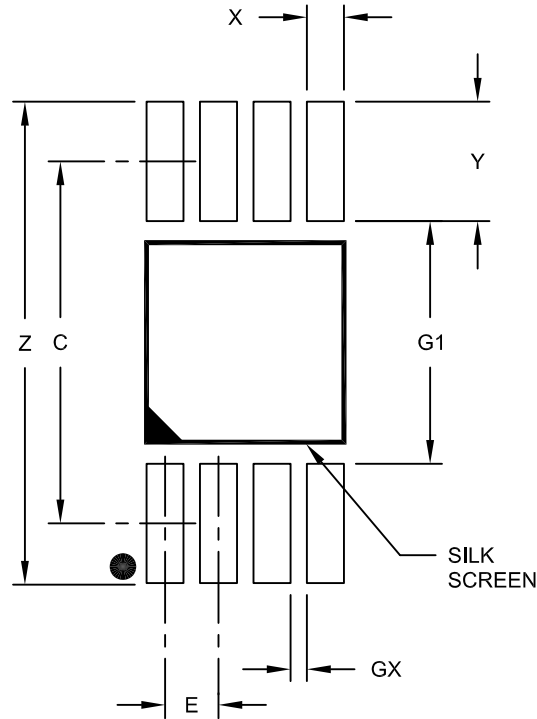

RECOMMENDED LAND PATTERN

Dimension Limits	Units	MILLIMETERS		
		MIN	NOM	MAX
Contact Pitch	E	0.65 BSC		
Contact Pad Spacing	C		4.40	
Overall Width	Z			5.85
Contact Pad Width (X8)	X1			0.45
Contact Pad Length (X8)	Y1			1.45
Distance Between Pads	G1	2.95		
Distance Between Pads	GX	0.20		

**Notes:**

1. Dimensioning and tolerancing per ASME Y14.5M

BSC: Basic Dimension. Theoretically exact value shown without tolerances.

Microchip Technology Drawing No. C04-2111A

# PIC12(L)F1571/2

## 8-Lead Plastic Dual Flat, No Lead Package (MF) - 3x3x0.9mm Body [DFN]

**Note:** For the most current package drawings, please see the Microchip Packaging Specification located at <http://www.microchip.com/packaging>

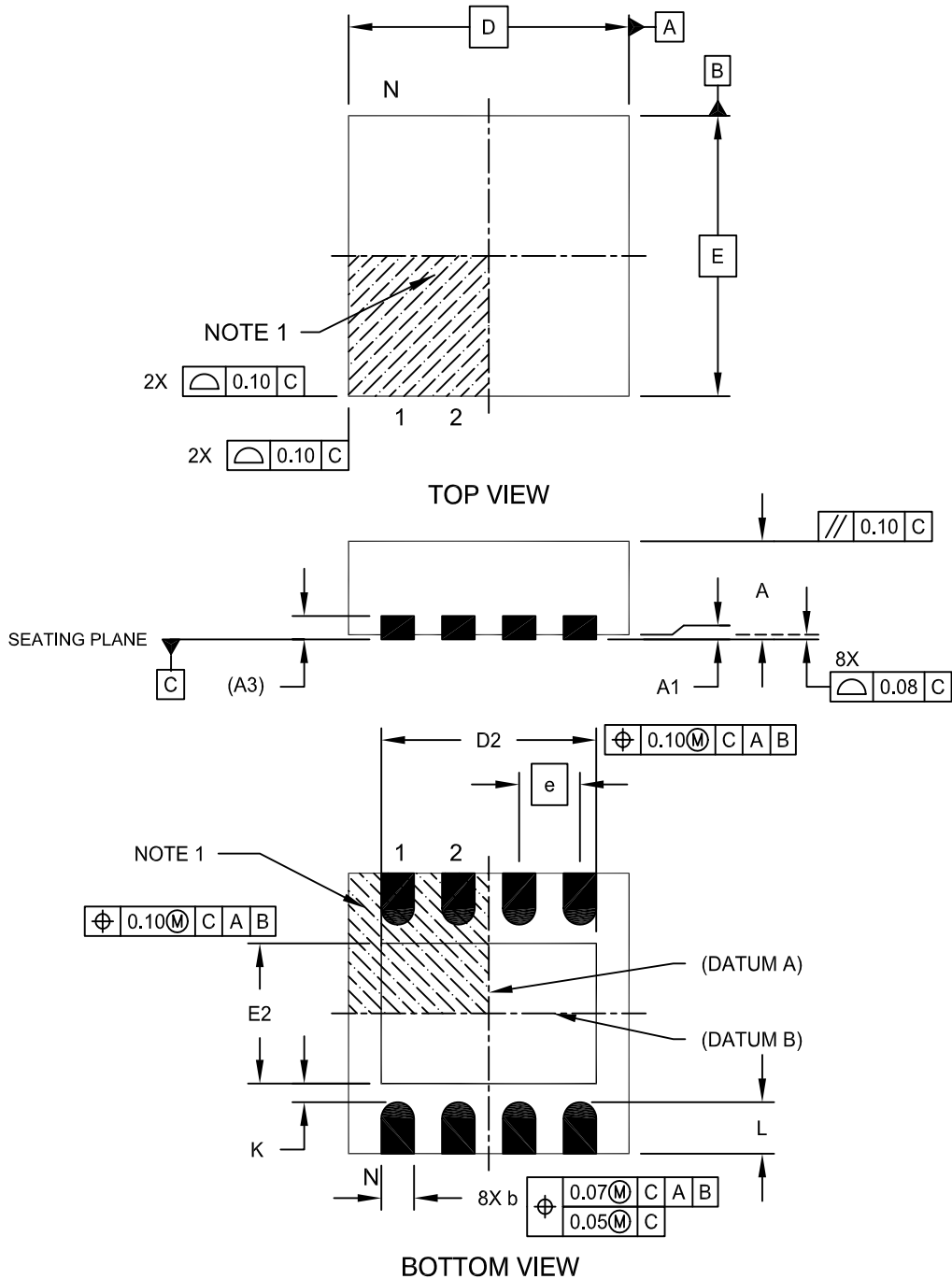

Microchip Technology Drawing No. C04-062C Sheet 1 of 2



## 8-Lead Plastic Dual Flat, No Lead Package (MF) - 3x3x0.9mm Body [DFN]

**Note:** For the most current package drawings, please see the Microchip Packaging Specification located at <http://www.microchip.com/packaging>

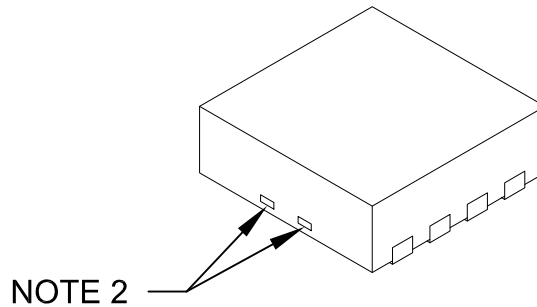

Dimension Limits	Units	MILLIMETERS		
		MIN	NOM	MAX
Number of Pins	N	8		
Pitch	e	0.65 BSC		
Overall Height	A	0.80	0.90	1.00
Standoff	A1	0.00	0.02	0.05
Contact Thickness	A3	0.20 REF		
Overall Length	D	3.00 BSC		
Exposed Pad Width	E2	1.34	-	1.60
Overall Width	E	3.00 BSC		
Exposed Pad Length	D2	1.60	-	2.40
Contact Width	b	0.25	0.30	0.35
Contact Length	L	0.20	0.30	0.55
Contact-to-Exposed Pad	K	0.20	-	-

**Notes:**

- Pin 1 visual index feature may vary, but must be located within the hatched area.
- Package may have one or more exposed tie bars at ends.
- Package is saw singulated
- Dimensioning and tolerancing per ASME Y14.5M

BSC: Basic Dimension. Theoretically exact value shown without tolerances.

REF: Reference Dimension, usually without tolerance, for information purposes only.

Microchip Technology Drawing No. C04-062C Sheet 2 of 2

# PIC12(L)F1571/2

## 8-Lead Plastic Dual Flat, No Lead Package (MF) - 3x3x0.9mm Body [DFN]

**Note:** For the most current package drawings, please see the Microchip Packaging Specification located at <http://www.microchip.com/packaging>

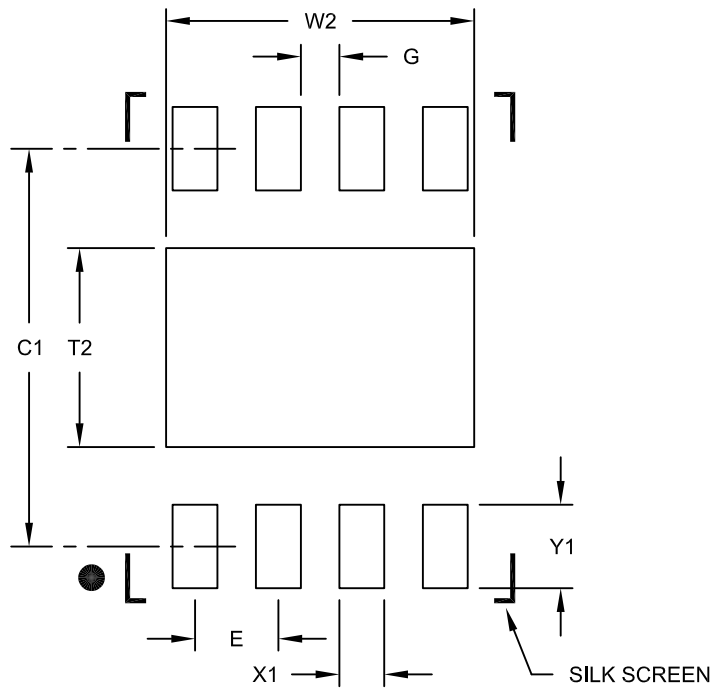

RECOMMENDED LAND PATTERN

Dimension Limits	Units	MILLIMETERS		
		MIN	NOM	MAX
Contact Pitch	E	0.65 BSC		
Optional Center Pad Width	W2			2.40
Optional Center Pad Length	T2			1.55
Contact Pad Spacing	C1		3.10	
Contact Pad Width (X8)	X1			0.35
Contact Pad Length (X8)	Y1			0.65
Distance Between Pads	G	0.30		

**Notes:**

1. Dimensioning and tolerancing per ASME Y14.5M

BSC: Basic Dimension. Theoretically exact value shown without tolerances.

Microchip Technology Drawing No. C04-2062B

8-Lead Ultra Thin Plastic Dual Flat, No Lead Package (RF) - 3x3x0.50 mm Body [UDFN]

**Note:** For the most current package drawings, please see the Microchip Packaging Specification located at <http://www.microchip.com/packaging>

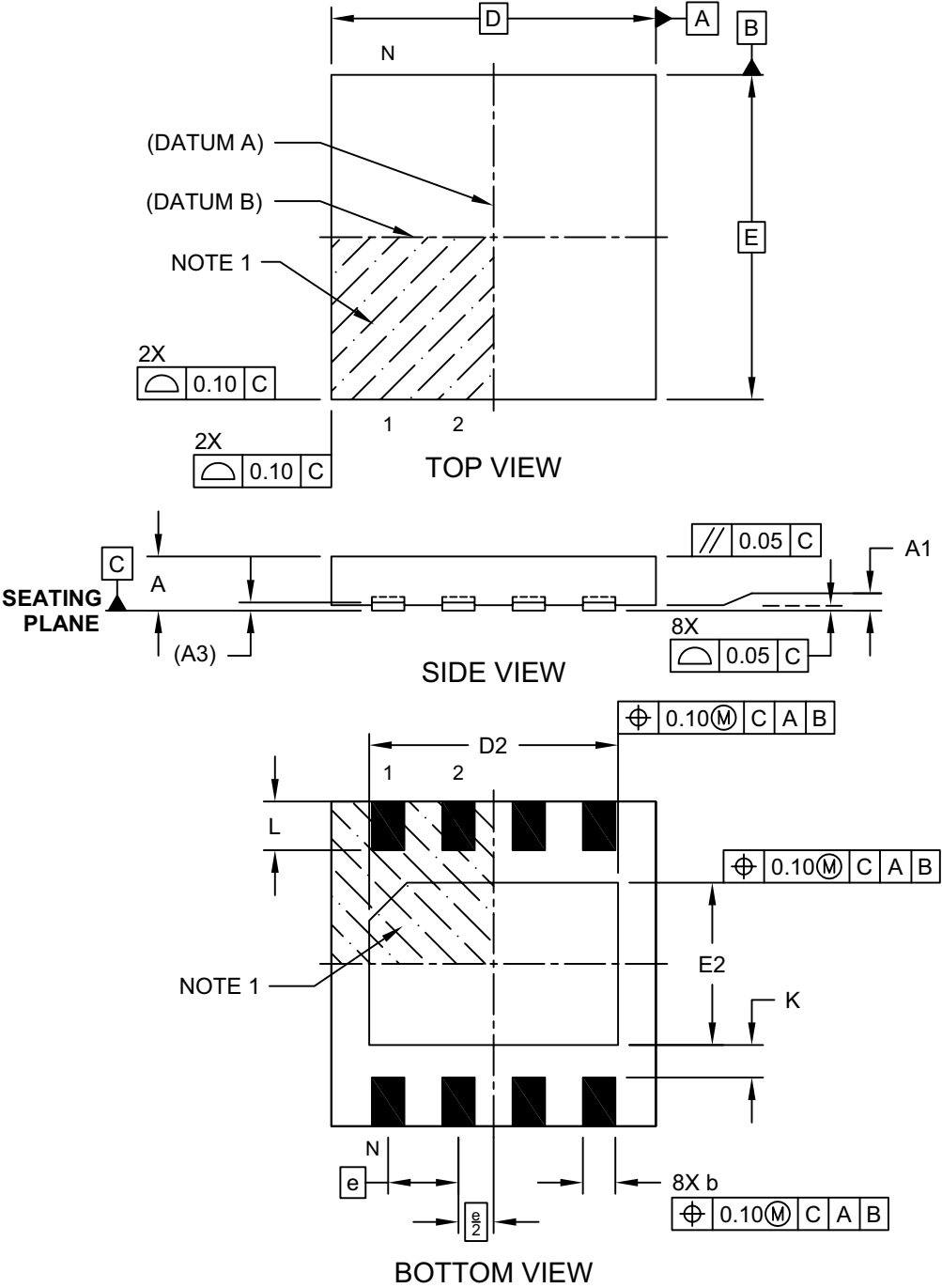

Microchip Technology Drawing C04-254A Sheet 1 of 2

# PIC12(L)F1571/2

## 8-Lead Ultra Thin Plastic Dual Flat, No Lead Package (RF) - 3x3x0.50 mm Body [UDFN]

**Note:** For the most current package drawings, please see the Microchip Packaging Specification located at <http://www.microchip.com/packaging>

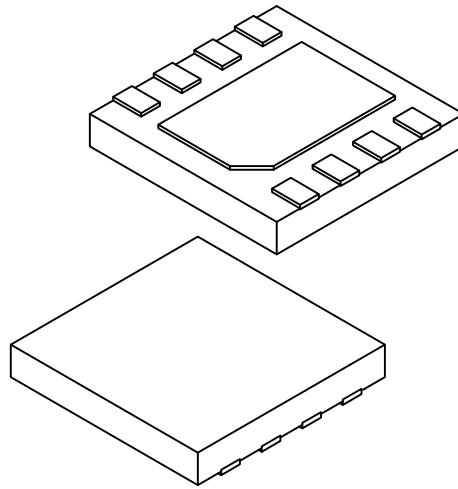

		Units	MILLIMETERS		
Dimension Limits			MIN	NOM	MAX
Number of Terminals	N		8		
Pitch	e		0.65 BSC		
Overall Height	A		0.45	0.50	0.55
Standoff	A1		0.00	0.02	0.05
Terminal Thickness	A3		0.065 REF		
Overall Width	E		3.00 BSC		
Exposed Pad Width	E2		1.40	1.50	1.60
Overall Length	D		3.00 BSC		
Exposed Pad Length	D2		2.20	2.30	2.40
Terminal Width	b		0.25	0.30	0.35
Terminal Length	L		0.35	0.45	0.55
Terminal-to-Exposed-Pad	K		0.20	-	-

**Notes:**

1. Pin 1 visual index feature may vary, but must be located within the hatched area.
2. Package is saw singulated
3. Dimensioning and tolerancing per ASME Y14.5M

BSC: Basic Dimension. Theoretically exact value shown without tolerances.

REF: Reference Dimension, usually without tolerance, for information purposes only.

Microchip Technology Drawing C04-254A Sheet 2 of 2

## 8-Lead Ultra Thin Plastic Dual Flat, No Lead Package (RF) - 3x3x0.50 mm Body [UDFN]

**Note:** For the most current package drawings, please see the Microchip Packaging Specification located at <http://www.microchip.com/packaging>

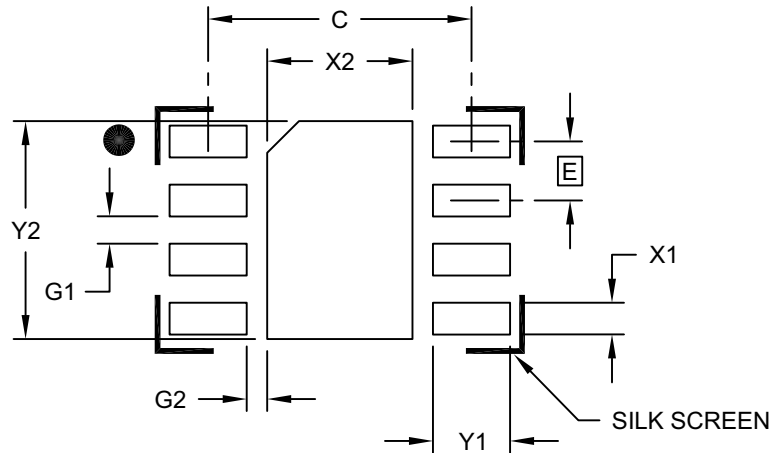

### RECOMMENDED LAND PATTERN

Dimension Limits	Units	MILLIMETERS		
		MIN	NOM	MAX
Contact Pitch	E	0.65 BSC		
Optional Center Pad Width	X2			1.60
Optional Center Pad Length	Y2			2.40
Contact Pad Spacing	C		2.90	
Contact Pad Width (X8)	X1			0.35
Contact Pad Length (X8)	Y1			0.85
Contact Pad to Contact Pad (X6)	G1	0.20		
Contact Pad to Center Pad (X8)	G2	0.30		

**Notes:**

1. Dimensioning and tolerancing per ASME Y14.5M

BSC: Basic Dimension. Theoretically exact value shown without tolerances.

Microchip Technology Drawing C04-2254A

# PIC12(L)F1571/2

---

NOTES:

## APPENDIX A: DATA SHEET REVISION HISTORY

### Revision A (10/2013)

Original release of this document.

### Revision B (2/2014)

Updated PIC12(L)F1571/2 Family Types table  
Program Memory Flash heading (*words to K words*).

### Revision C (8/2014)

Updated PWM chapter. Changed to Final data sheet.  
Updated IDD and IPD parameters in the Electrical  
Specification chapter. Added Characterization Graphs.

Added Section 1.1: Register and Bit Naming  
Conventions.

Updated Figures 5-3 and 15-5. Updated Tables 3-1,  
3-7, and 3-10. Updated Section 15.2.5. Updated Equa-  
tion 15-1.

### Revision D (8/2015)

Updated Clocking Structure, Memory, Low-Power  
Features, Family Types table and Pin Diagram Table  
on cover pages.

Added Sections 3.2: High-Endurance Flash and  
5.4: Clock Switching Before Sleep. Added Table 29-2  
and 8-pin UDFN packaging.

Updated Examples 3-2 and 15-1.

Updated Figures 8-1, 21-1, 22-8 through 22-13 and  
23-1.

Updated Registers 7-5, 8-1, 22-6 and 23-3.

Updated Sections 8.2.2, 15.2.6, 16.0, 21.0, 21.4.2,  
22.3.3, 23.9.1.2, 23.11.1, 26.1 and 29.1.

Updated Tables 1, 3-3, 3-4, 3-10, 5-1, 16-1, 17-3, 22-2,  
23-2, 26-6, 26-8 and 29-1.

# PIC12(L)F1571/2

---

NOTES:



## THE MICROCHIP WEB SITE

Microchip provides online support via our WWW site at [www.microchip.com](http://www.microchip.com). This web site is used as a means to make files and information easily available to customers. Accessible by using your favorite Internet browser, the web site contains the following information:

- **Product Support** – Data sheets and errata, application notes and sample programs, design resources, user's guides and hardware support documents, latest software releases and archived software
- **General Technical Support** – Frequently Asked Questions (FAQ), technical support requests, online discussion groups, Microchip consultant program member listing
- **Business of Microchip** – Product selector and ordering guides, latest Microchip press releases, listing of seminars and events, listings of Microchip sales offices, distributors and factory representatives

## CUSTOMER CHANGE NOTIFICATION SERVICE

Microchip's customer notification service helps keep customers current on Microchip products. Subscribers will receive e-mail notification whenever there are changes, updates, revisions or errata related to a specified product family or development tool of interest.

To register, access the Microchip web site at [www.microchip.com](http://www.microchip.com). Under "Support", click on "Customer Change Notification" and follow the registration instructions.

## CUSTOMER SUPPORT

Users of Microchip products can receive assistance through several channels:

- Distributor or Representative
- Local Sales Office
- Field Application Engineer (FAE)
- Technical Support

Customers should contact their distributor, representative or Field Application Engineer (FAE) for support. Local sales offices are also available to help customers. A listing of sales offices and locations is included in the back of this document.

**Technical support is available through the web site at: <http://microchip.com/support>**

# PIC12(L)F1571/2

---

NOTES:

## PRODUCT IDENTIFICATION SYSTEM

To order or obtain information, e.g., on pricing or delivery, refer to the factory or the listed sales office.

<u>PART NO.</u>		<u>[X]<sup>(1)</sup></u>	-	<u>X</u>	<u>/XX</u>	<u>XXX</u>
Device	Tape and Reel Option			Temperature Range	Package	Pattern
<p><b>Device:</b> PIC12LF1571, PIC12F1571 PIC12LF1572, PIC12F1572</p>						
<p><b>Tape and Reel Option:</b> Blank = Standard packaging (tube or tray) T = Tape and Reel<sup>(1)</sup></p>						
<p><b>Temperature Range:</b> I = -40°C to +85°C (Industrial) E = -40°C to +125°C (Extended)</p>						
<p><b>Package:<sup>(2)</sup></b> MF = Micro Lead Frame (DFN) 3x3x0.9 mm MS = MSOP P = Plastic DIP SN = SOIC RF = Micro Lead Frame (UDFN) 3x3x0.5 mm</p>						
<p><b>Pattern:</b> QTP, SQTP, Code or Special Requirements (blank otherwise)</p>						

**Examples:**

- a) PIC12LF1571T - I/SO  
Tape and Reel,  
Industrial temperature,  
SOIC package
- b) PIC12F1572 - I/P  
Industrial temperature,  
PDIP package
- c) PIC12F1571-E/MF  
Extended Temperature,  
DFN package

**Note 1:** Tape and Reel identifier only appears in the catalog part number description. This identifier is used for ordering purposes and is not printed on the device package. Check with your Microchip Sales Office for package availability with the Tape and Reel option.

**2:** For other small form-factor package availability and marking information, please visit [www.microchip.com/packaging](http://www.microchip.com/packaging) or contact your local sales office.

# PIC12(L)F1571/2

---

NOTES:

---

**Note the following details of the code protection feature on Microchip devices:**

- Microchip products meet the specification contained in their particular Microchip Data Sheet.
- Microchip believes that its family of products is one of the most secure families of its kind on the market today, when used in the intended manner and under normal conditions.
- There are dishonest and possibly illegal methods used to breach the code protection feature. All of these methods, to our knowledge, require using the Microchip products in a manner outside the operating specifications contained in Microchip's Data Sheets. Most likely, the person doing so is engaged in theft of intellectual property.
- Microchip is willing to work with the customer who is concerned about the integrity of their code.
- Neither Microchip nor any other semiconductor manufacturer can guarantee the security of their code. Code protection does not mean that we are guaranteeing the product as “unbreakable.”

Code protection is constantly evolving. We at Microchip are committed to continuously improving the code protection features of our products. Attempts to break Microchip's code protection feature may be a violation of the Digital Millennium Copyright Act. If such acts allow unauthorized access to your software or other copyrighted work, you may have a right to sue for relief under that Act.

---

Information contained in this publication regarding device applications and the like is provided only for your convenience and may be superseded by updates. It is your responsibility to ensure that your application meets with your specifications. MICROCHIP MAKES NO REPRESENTATIONS OR WARRANTIES OF ANY KIND WHETHER EXPRESS OR IMPLIED, WRITTEN OR ORAL, STATUTORY OR OTHERWISE, RELATED TO THE INFORMATION, INCLUDING BUT NOT LIMITED TO ITS CONDITION, QUALITY, PERFORMANCE, MERCHANTABILITY OR FITNESS FOR PURPOSE. Microchip disclaims all liability arising from this information and its use. Use of Microchip devices in life support and/or safety applications is entirely at the buyer's risk, and the buyer agrees to defend, indemnify and hold harmless Microchip from any and all damages, claims, suits, or expenses resulting from such use. No licenses are conveyed, implicitly or otherwise, under any Microchip intellectual property rights unless otherwise stated.

#### **Trademarks**

The Microchip name and logo, the Microchip logo, dsPIC, FlashFlex, flexPWR, JukeBlox, KEELOQ, KEELOQ logo, Klear, LANCheck, MediaLB, MOST, MOST logo, MPLAB, OptoLyzer, PIC, PICSTART, PIC<sup>32</sup> logo, RightTouch, SpyNIC, SST, SST Logo, SuperFlash and UNI/O are registered trademarks of Microchip Technology Incorporated in the U.S.A. and other countries.

The Embedded Control Solutions Company and mTouch are registered trademarks of Microchip Technology Incorporated in the U.S.A.

Analog-for-the-Digital Age, BodyCom, chipKIT, chipKIT logo, CodeGuard, dsPICDEM, dsPICDEM.net, ECAN, In-Circuit Serial Programming, ICSP, Inter-Chip Connectivity, KlearNet, KlearNet logo, MiWi, MPASM, MPF, MPLAB Certified logo, MPLIB, MPLINK, MultiTRAK, NetDetach, Omniscient Code Generation, PICDEM, PICDEM.net, PICkit, PICtail, RightTouch logo, REAL ICE, SQI, Serial Quad I/O, Total Endurance, TSHARC, USBCheck, VariSense, ViewSpan, WiperLock, Wireless DNA, and ZENA are trademarks of Microchip Technology Incorporated in the U.S.A. and other countries.

SQTP is a service mark of Microchip Technology Incorporated in the U.S.A.

Silicon Storage Technology is a registered trademark of Microchip Technology Inc. in other countries.

GestIC is a registered trademark of Microchip Technology Germany II GmbH & Co. KG, a subsidiary of Microchip Technology Inc., in other countries.

All other trademarks mentioned herein are property of their respective companies.

© 2013-2015, Microchip Technology Incorporated, Printed in the U.S.A., All Rights Reserved.

ISBN: 978-1-63277-715-7

**QUALITY MANAGEMENT SYSTEM**  
**CERTIFIED BY DNV**  
**== ISO/TS 16949 ==**

*Microchip received ISO/TS-16949:2009 certification for its worldwide headquarters, design and wafer fabrication facilities in Chandler and Tempe, Arizona; Gresham, Oregon and design centers in California and India. The Company's quality system processes and procedures are for its PIC<sup>®</sup> MCUs and dsPIC<sup>®</sup> DSCs, KEELOQ<sup>®</sup> code hopping devices, Serial EEPROMs, microperipherals, nonvolatile memory and analog products. In addition, Microchip's quality system for the design and manufacture of development systems is ISO 9001:2000 certified.*



# MICROCHIP

## Worldwide Sales and Service

### AMERICAS

**Corporate Office**  
2355 West Chandler Blvd.  
Chandler, AZ 85224-6199  
Tel: 480-792-7200  
Fax: 480-792-7277  
Technical Support:  
<http://www.microchip.com/support>  
Web Address:  
[www.microchip.com](http://www.microchip.com)

**Atlanta**  
Duluth, GA  
Tel: 678-957-9614  
Fax: 678-957-1455

**Austin, TX**  
Tel: 512-257-3370

**Boston**  
Westborough, MA  
Tel: 774-760-0087  
Fax: 774-760-0088

**Chicago**  
Itasca, IL  
Tel: 630-285-0071  
Fax: 630-285-0075

**Cleveland**  
Independence, OH  
Tel: 216-447-0464  
Fax: 216-447-0643

**Dallas**  
Addison, TX  
Tel: 972-818-7423  
Fax: 972-818-2924

**Detroit**  
Novi, MI  
Tel: 248-848-4000

**Houston, TX**  
Tel: 281-894-5983

**Indianapolis**  
Noblesville, IN  
Tel: 317-773-8323  
Fax: 317-773-5453

**Los Angeles**  
Mission Viejo, CA  
Tel: 949-462-9523  
Fax: 949-462-9608

**New York, NY**  
Tel: 631-435-6000

**San Jose, CA**  
Tel: 408-735-9110

**Canada - Toronto**  
Tel: 905-673-0699  
Fax: 905-673-6509

### ASIA/PACIFIC

**Asia Pacific Office**  
Suites 3707-14, 37th Floor  
Tower 6, The Gateway  
Harbour City, Kowloon

**Hong Kong**  
Tel: 852-2943-5100  
Fax: 852-2401-3431

**Australia - Sydney**  
Tel: 61-2-9868-6733  
Fax: 61-2-9868-6755

**China - Beijing**  
Tel: 86-10-8569-7000  
Fax: 86-10-8528-2104

**China - Chengdu**  
Tel: 86-28-8665-5511  
Fax: 86-28-8665-7889

**China - Chongqing**  
Tel: 86-23-8980-9588  
Fax: 86-23-8980-9500

**China - Dongguan**  
Tel: 86-769-8702-9880

**China - Hangzhou**  
Tel: 86-571-8792-8115  
Fax: 86-571-8792-8116

**China - Hong Kong SAR**  
Tel: 852-2943-5100  
Fax: 852-2401-3431

**China - Nanjing**  
Tel: 86-25-8473-2460  
Fax: 86-25-8473-2470

**China - Qingdao**  
Tel: 86-532-8502-7355  
Fax: 86-532-8502-7205

**China - Shanghai**  
Tel: 86-21-5407-5533  
Fax: 86-21-5407-5066

**China - Shenyang**  
Tel: 86-24-2334-2829  
Fax: 86-24-2334-2393

**China - Shenzhen**  
Tel: 86-755-8864-2200  
Fax: 86-755-8203-1760

**China - Wuhan**  
Tel: 86-27-5980-5300  
Fax: 86-27-5980-5118

**China - Xian**  
Tel: 86-29-8833-7252  
Fax: 86-29-8833-7256

### ASIA/PACIFIC

**China - Xiamen**  
Tel: 86-592-2388138  
Fax: 86-592-2388130

**China - Zhuhai**  
Tel: 86-756-3210040  
Fax: 86-756-3210049

**India - Bangalore**  
Tel: 91-80-3090-4444  
Fax: 91-80-3090-4123

**India - New Delhi**  
Tel: 91-11-4160-8631  
Fax: 91-11-4160-8632

**India - Pune**  
Tel: 91-20-3019-1500

**Japan - Osaka**  
Tel: 81-6-6152-7160  
Fax: 81-6-6152-9310

**Japan - Tokyo**  
Tel: 81-3-6880-3770  
Fax: 81-3-6880-3771

**Korea - Daegu**  
Tel: 82-53-744-4301  
Fax: 82-53-744-4302

**Korea - Seoul**  
Tel: 82-2-554-7200  
Fax: 82-2-558-5932 or  
82-2-558-5934

**Malaysia - Kuala Lumpur**  
Tel: 60-3-6201-9857  
Fax: 60-3-6201-9859

**Malaysia - Penang**  
Tel: 60-4-227-8870  
Fax: 60-4-227-4068

**Philippines - Manila**  
Tel: 63-2-634-9065  
Fax: 63-2-634-9069

**Singapore**  
Tel: 65-6334-8870  
Fax: 65-6334-8850

**Taiwan - Hsin Chu**  
Tel: 886-3-5778-366  
Fax: 886-3-5770-955

**Taiwan - Kaohsiung**  
Tel: 886-7-213-7828

**Taiwan - Taipei**  
Tel: 886-2-2508-8600  
Fax: 886-2-2508-0102

**Thailand - Bangkok**  
Tel: 66-2-694-1351  
Fax: 66-2-694-1350

### EUROPE

**Austria - Wels**  
Tel: 43-7242-2244-39  
Fax: 43-7242-2244-393

**Denmark - Copenhagen**  
Tel: 45-4450-2828  
Fax: 45-4485-2829

**France - Paris**  
Tel: 33-1-69-53-63-20  
Fax: 33-1-69-30-90-79

**Germany - Dusseldorf**  
Tel: 49-2129-3766400

**Germany - Karlsruhe**  
Tel: 49-721-625370

**Germany - Munich**  
Tel: 49-89-627-144-0  
Fax: 49-89-627-144-44

**Italy - Milan**  
Tel: 39-0331-742611  
Fax: 39-0331-466781

**Italy - Venice**  
Tel: 39-049-7625286

**Netherlands - Drunen**  
Tel: 31-416-690399  
Fax: 31-416-690340

**Poland - Warsaw**  
Tel: 48-22-3325737

**Spain - Madrid**  
Tel: 34-91-708-08-90  
Fax: 34-91-708-08-91

**Sweden - Stockholm**  
Tel: 46-8-5090-4654

**UK - Wokingham**  
Tel: 44-118-921-5800  
Fax: 44-118-921-5820

07/14/15