



PIC18F85J90 Family Data Sheet

**64/80-Pin, High-Performance
Microcontrollers with LCD Driver
and nanoWatt Technology**

Note the following details of the code protection feature on Microchip devices:

- Microchip products meet the specification contained in their particular Microchip Data Sheet.
- Microchip believes that its family of products is one of the most secure families of its kind on the market today, when used in the intended manner and under normal conditions.
- There are dishonest and possibly illegal methods used to breach the code protection feature. All of these methods, to our knowledge, require using the Microchip products in a manner outside the operating specifications contained in Microchip's Data Sheets. Most likely, the person doing so is engaged in theft of intellectual property.
- Microchip is willing to work with the customer who is concerned about the integrity of their code.
- Neither Microchip nor any other semiconductor manufacturer can guarantee the security of their code. Code protection does not mean that we are guaranteeing the product as "unbreakable."

Code protection is constantly evolving. We at Microchip are committed to continuously improving the code protection features of our products. Attempts to break Microchip's code protection feature may be a violation of the Digital Millennium Copyright Act. If such acts allow unauthorized access to your software or other copyrighted work, you may have a right to sue for relief under that Act.

Information contained in this publication regarding device applications and the like is provided only for your convenience and may be superseded by updates. It is your responsibility to ensure that your application meets with your specifications. MICROCHIP MAKES NO REPRESENTATIONS OR WARRANTIES OF ANY KIND WHETHER EXPRESS OR IMPLIED, WRITTEN OR ORAL, STATUTORY OR OTHERWISE, RELATED TO THE INFORMATION, INCLUDING BUT NOT LIMITED TO ITS CONDITION, QUALITY, PERFORMANCE, MERCHANTABILITY OR FITNESS FOR PURPOSE. Microchip disclaims all liability arising from this information and its use. Use of Microchip devices in life support and/or safety applications is entirely at the buyer's risk, and the buyer agrees to defend, indemnify and hold harmless Microchip from any and all damages, claims, suits, or expenses resulting from such use. No licenses are conveyed, implicitly or otherwise, under any Microchip intellectual property rights.

Trademarks

The Microchip name and logo, the Microchip logo, Accuron, dsPIC, KEELOQ, KEELOQ logo, microID, MPLAB, PIC, PICmicro, PICSTART, PRO MATE, PowerSmart, rfPIC, and SmartShunt are registered trademarks of Microchip Technology Incorporated in the U.S.A. and other countries.

AmpLab, FilterLab, Linear Active Thermistor, Migratable Memory, MXDEV, MXLAB, PS logo, SEEVAL, SmartSensor and The Embedded Control Solutions Company are registered trademarks of Microchip Technology Incorporated in the U.S.A.

Analog-for-the-Digital Age, Application Maestro, CodeGuard, dsPICDEM, dsPICDEM.net, dsPICworks, ECAN, ECONOMONITOR, FanSense, FlexROM, fuzzyLAB, In-Circuit Serial Programming, ICSP, ICEPIC, Mindi, MiWi, MPASM, MPLAB Certified logo, MPLIB, MPLINK, PICkit, PICDEM, PICDEM.net, PICLAB, PICtail, PowerCal, PowerInfo, PowerMate, PowerTool, REAL ICE, rLAB, rfPICDEM, Select Mode, Smart Serial, SmartTel, Total Endurance, UNI/O, WiperLock and ZENA are trademarks of Microchip Technology Incorporated in the U.S.A. and other countries.

SQTP is a service mark of Microchip Technology Incorporated in the U.S.A.

All other trademarks mentioned herein are property of their respective companies.

© 2007, Microchip Technology Incorporated, Printed in the U.S.A., All Rights Reserved.

 Printed on recycled paper.

Microchip received ISO/TS-16949:2002 certification for its worldwide headquarters, design and wafer fabrication facilities in Chandler and Tempe, Arizona, Gresham, Oregon and Mountain View, California. The Company's quality system processes and procedures are for its PIC[®] MCUs and dsPIC[®] DSCs, KEELOQ[®] code hopping devices, Serial EEPROMs, microperipherals, nonvolatile memory and analog products. In addition, Microchip's quality system for the design and manufacture of development systems is ISO 9001:2000 certified.

**QUALITY MANAGEMENT SYSTEM
CERTIFIED BY DNV
== ISO/TS 16949:2002 ==**



MICROCHIP

PIC18F85J90 FAMILY

64/80-Pin, High-Performance Microcontrollers with LCD Driver and nanoWatt Technology

LCD Driver Module Features:

- Direct LCD Panel Drive Capability:
 - Can drive LCD panel while in Sleep mode
- Up to 48 Segments and 192 Pixels; Software Selectable
- Programmable LCD Timing module:
 - Multiple LCD timing sources available
 - Up to 4 commons: static, 1/2, 1/3 or 1/4 multiplex
 - Static, 1/2 or 1/3 Bias configuration
- Integrated Charge-Pump Module with Voltage Boost

Special Microcontroller Features:

- 1000 Erase/Write Cycle Flash Program Memory, typical
- Flash Retention: 20 Years Minimum
- Self-Programmable under Software Control
- Priority Levels for Interrupts
- 8 x 8 Single-Cycle Hardware Multiplier
- Extended Watchdog Timer (WDT):
 - Programmable period from 4 ms to 131s
- In-Circuit Serial Programming™ (ICSP™) via two pins
- In-Circuit Debug with 3 Breakpoints via two pins
- Operating Voltage Range: 2.0V to 3.6V
- On-Chip 2.5V Regulator

Flexible Oscillator Structure:

- Two Crystal modes, 4-25 MHz
- Two External Clock modes, up to 40 MHz
- Internal Oscillator Block:
 - 8 user-selectable frequencies from 31.25 kHz to 8 MHz
- Secondary Oscillator using Timer1 @ 32 kHz
- Fail-Safe Clock Monitor:
 - Allows for safe shutdown if peripheral clock fails

Low-Power Features:

- Power-Managed modes: Run, Idle, Sleep
- Run current down to 9 µA, typical
- Idle current down to 2.5 µA, typical
- Sleep current down to 0.1 µA, typical
- Fast INTOSC startup from SLEEP
- Two-Speed Oscillator Start-up reduces crystal stabilization wait time

Peripheral Highlights:

- High-Current Sink/Source: 25 mA/25 mA (PORTB and PORTC)
- Sleep current as low as 100nA
- Up to Four External Interrupts
- Four 8-Bit/16-Bit Timer/Counter modules
 - Uses Timer1
- Two Capture/Compare/PWM (CCP) modules:
 - Capture is 16-bit, max. resolution 6.25 ns (TCY/16)
 - Compare is 16-bit, max. resolution 100 ns (TCY)
 - PWM output: PWM resolution is up to 10-bit
- Master Synchronous Serial Port (MSSP) module with two modes of Operation:
 - 3-wire/4-wire SPI (supports all 4 SPI modes)
 - I²C™ Master and Slave mode
- One Addressable USART module
- One Enhanced USART module:
 - Supports LIN 1.2
 - Auto-wake-up on Start bit and Break character
 - Auto-Baud Detect
- 10-Bit, up to 12-Channel A/D Converter:
 - Auto-acquisition
 - Conversion available during Sleep
- Two Analog Comparators
- Programmable Reference Voltage for Comparators

Device	Program Memory		SRAM Data Memory (bytes)	I/O	LCD (Pixels)	Timers 8/16-Bit	CCP	MSSP		EUSART/AUSART	10-Bit A/D (ch)	Comparators	BOR/LVD
	Flash (bytes)	# Single-Word Instructions						SPI	Master I ² C™				
PIC18F63J90	8K	4096	1024	51	132	1/3	2	Y	Y	1/1	12	2	Y
PIC18F64J90	16K	8192	1024	51	132	1/3	2	Y	Y	1/1	12	2	Y
PIC18F65J90	32K	16384	2048	51	132	1/3	2	Y	Y	1/1	12	2	Y
PIC18F83J90	8K	4096	1024	67	192	1/3	2	Y	Y	1/1	12	2	Y
PIC18F84J90	16K	8192	1024	67	192	1/3	2	Y	Y	1/1	12	2	Y
PIC18F85J90	32K	16384	2048	67	192	1/3	2	Y	Y	1/1	12	2	Y

PIC18F85J90 FAMILY

Pin Diagrams

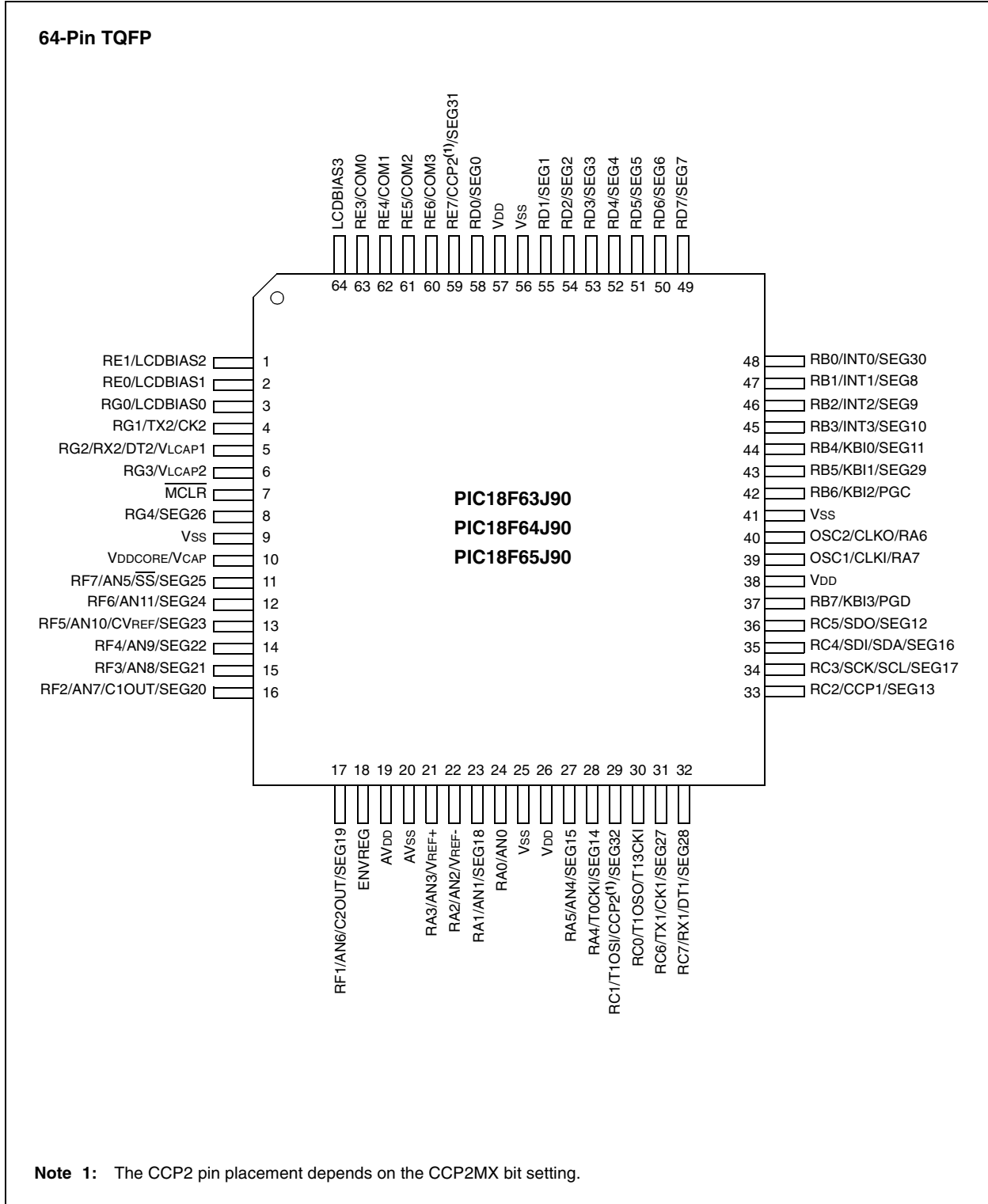

PIC18F85J90 FAMILY

Pin Diagrams (Continued)

80-Pin TQFP

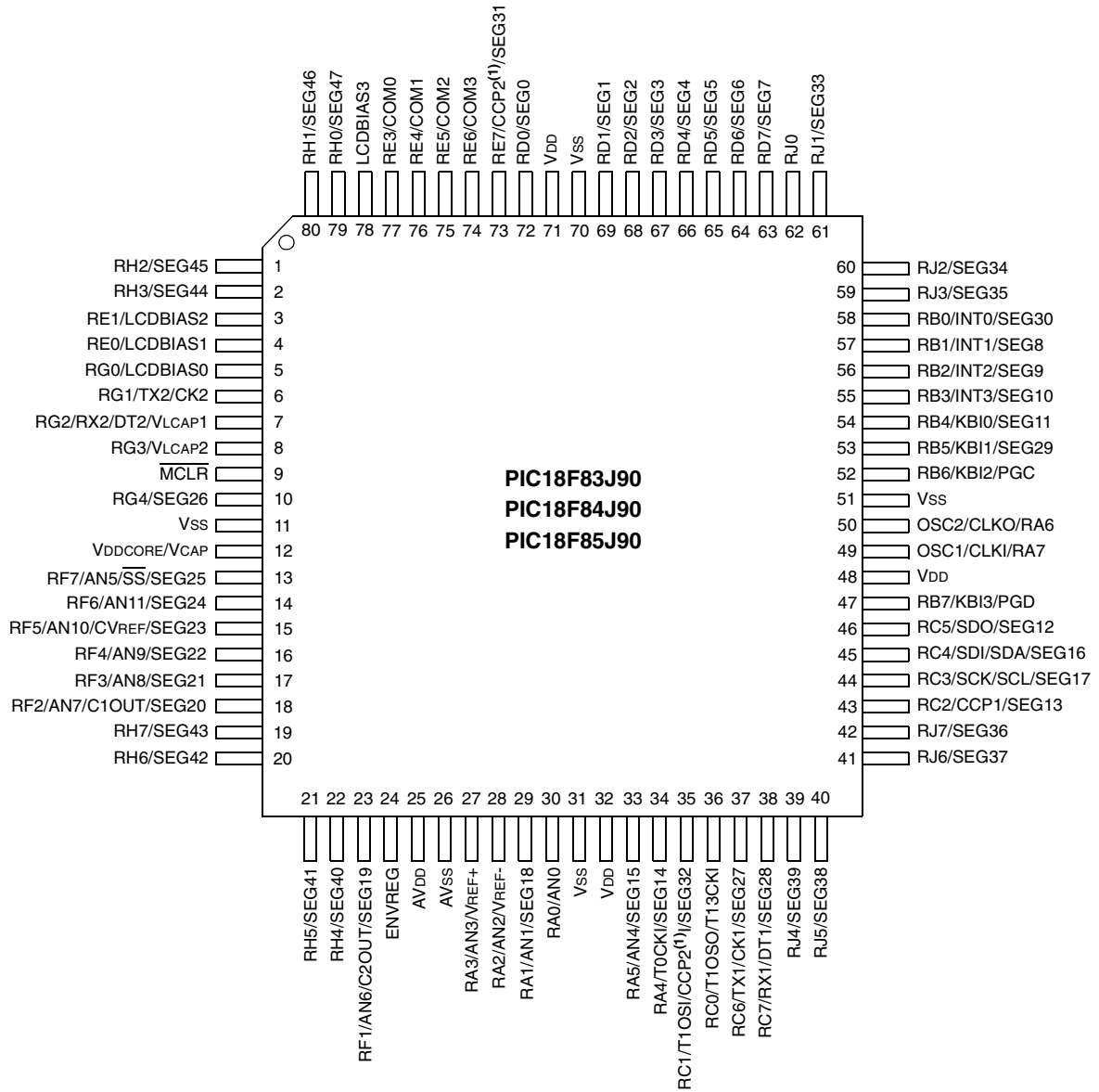

Note 1: The CCP2 pin placement depends on the CCP2MX bit setting.

PIC18F85J90 FAMILY

Table of Contents

1.0	Device Overview	7
2.0	Oscillator Configurations	29
3.0	Power-Managed Modes	37
4.0	Reset	45
5.0	Memory Organization	57
6.0	Flash Program Memory	81
7.0	8 x 8 Hardware Multiplier	91
8.0	Interrupts	93
9.0	I/O Ports	109
10.0	Timer0 Module	131
11.0	Timer1 Module	135
12.0	Timer2 Module	141
13.0	Timer3 Module	143
14.0	Capture/Compare/PWM (CCP) Modules	147
15.0	Liquid Crystal Display (LCD) Driver Module	157
16.0	Master Synchronous Serial Port (MSSP) Module	185
17.0	Enhanced Universal Synchronous Asynchronous Receiver Transmitter (EUSART)	229
18.0	Addressable Universal Synchronous Asynchronous Receiver Transmitter (AUSART)	249
19.0	10-bit Analog-to-Digital Converter (A/D) Module	263
20.0	Comparator Module	273
21.0	Comparator Voltage Reference Module	279
22.0	Special Features of the CPU	283
23.0	Instruction Set Summary	295
24.0	Development Support	345
25.0	Electrical Characteristics	349
26.0	DC and AC Characteristics Graphs and Tables	387
27.0	Packaging Information	389
	Appendix A: Revision History	393
	Appendix B: Migration Between High-End Device Families	393
	Index	397
	The Microchip Web Site	407
	Customer Change Notification Service	407
	Customer Support	407
	Reader Response	408
	Product Identification System	409

TO OUR VALUED CUSTOMERS

It is our intention to provide our valued customers with the best documentation possible to ensure successful use of your Microchip products. To this end, we will continue to improve our publications to better suit your needs. Our publications will be refined and enhanced as new volumes and updates are introduced.

If you have any questions or comments regarding this publication, please contact the Marketing Communications Department via E-mail at docerrors@microchip.com or fax the **Reader Response Form** in the back of this data sheet to (480) 792-4150. We welcome your feedback.

Most Current Data Sheet

To obtain the most up-to-date version of this data sheet, please register at our Worldwide Web site at:

<http://www.microchip.com>

You can determine the version of a data sheet by examining its literature number found on the bottom outside corner of any page. The last character of the literature number is the version number, (e.g., DS30000A is version A of document DS30000).

Errata

An errata sheet, describing minor operational differences from the data sheet and recommended workarounds, may exist for current devices. As device/documentation issues become known to us, we will publish an errata sheet. The errata will specify the revision of silicon and revision of document to which it applies.

To determine if an errata sheet exists for a particular device, please check with one of the following:

- Microchip's Worldwide Web site; <http://www.microchip.com>
- Your local Microchip sales office (see last page)

When contacting a sales office, please specify which device, revision of silicon and data sheet (include literature number) you are using.

Customer Notification System

Register on our web site at www.microchip.com to receive the most current information on all of our products.

PIC18F85J90 FAMILY

NOTES:

1.0 DEVICE OVERVIEW

This document contains device specific information for the following devices:

- PIC18F63J90
- PIC18F64J90
- PIC18F65J90
- PIC18F83J90
- PIC18F84J90
- PIC18F85J90

This family combines the traditional advantages of all PIC18 microcontrollers – namely, high computational performance and a rich feature set – with a versatile on-chip LCD driver, while maintaining an extremely competitive price point. These features make the PIC18F85J90 family a logical choice for many high-performance applications where price is a primary consideration.

1.1 Core Features

1.1.1 nanoWatt TECHNOLOGY

All of the devices in the PIC18F85J90 family incorporate a range of features that can significantly reduce power consumption during operation. Key items include:

- **Alternate Run Modes:** By clocking the controller from the Timer1 source or the internal RC oscillator, power consumption during code execution can be reduced by as much as 90%.
- **Multiple Idle Modes:** The controller can also run with its CPU core disabled but the peripherals still active. In these states, power consumption can be reduced even further, to as little as 4% of normal operation requirements.
- **On-the-Fly Mode Switching:** The power-managed modes are invoked by user code during operation, allowing the user to incorporate power-saving ideas into their application's software design.

1.1.2 OSCILLATOR OPTIONS AND FEATURES

All of the devices in the PIC18F85J90 family offer six different oscillator options, allowing users a range of choices in developing application hardware. These include:

- Two Crystal modes, using crystals or ceramic resonators.
- Two External Clock modes, offering the option of a divide-by-4 clock output.
- A Phase Lock Loop (PLL) frequency multiplier, available to the External Oscillator modes which allows clock speeds of up to 40 MHz.
- An internal oscillator block which provides an 8 MHz clock ($\pm 2\%$ accuracy) and an INTRC source (approximately 31 kHz, stable over temperature and VDD), as well as a range of six user-selectable clock frequencies, between 125 kHz to 4 MHz, for a total of eight clock frequencies. This option frees the two oscillator pins for use as additional general purpose I/O.

The internal oscillator block provides a stable reference source that gives the family additional features for robust operation:

- **Fail-Safe Clock Monitor:** This option constantly monitors the main clock source against a reference signal provided by the internal oscillator. If a clock failure occurs, the controller is switched to the internal oscillator, allowing for continued low-speed operation or a safe application shutdown.
- **Two-Speed Start-up:** This option allows the internal oscillator to serve as the clock source from Power-on Reset, or wake-up from Sleep mode, until the primary clock source is available.

1.1.3 MEMORY OPTIONS

The PIC18F85J90 family provides a range of program memory options, from 8 Kbytes to 32 Kbytes of code space. The Flash cells for program memory are rated to last up to 1000 erase/write cycles. Data retention without refresh is conservatively estimated to be greater than 20 years.

The PIC18F85J90 family also provides plenty of room for dynamic application data, with up to 2048 bytes of data RAM.

1.1.4 EXTENDED INSTRUCTION SET

The PIC18F85J90 family implements the optional extension to the PIC18 instruction set, adding 8 new instructions and an Indexed Addressing mode. Enabled as a device configuration option, the extension has been specifically designed to optimize re-entrant application code originally developed in high-level languages, such as 'C'.

1.1.5 EASY MIGRATION

Regardless of the memory size, all devices share the same rich set of peripherals, allowing for a smooth migration path as applications grow and evolve.

The consistent pinout scheme used throughout the entire family also aids in migrating to the next larger device. This is true when moving between the 64-pin members, between the 80-pin members, or even jumping from 64-pin to 80-pin devices.

The PIC18F85J90 family is also largely pin compatible with other PIC18 families, such as the PIC18F8720 and PIC18F8722, as well as the PIC18F8490 family of microcontrollers with LCD drivers. This allows a new dimension to the evolution of applications, allowing developers to select different price points within Microchip's PIC18 portfolio, while maintaining a similar feature set.

PIC18F85J90 FAMILY

1.2 LCD Driver

The on-chip LCD driver includes many features that make the integration of displays in low-power applications easier. These include an integrated voltage regulator with charge pump that allows contrast control in software and display operation above device VDD.

1.3 Other Special Features

- **Communications:** The PIC18F85J90 family incorporates a range of serial communication peripherals, including an Addressable USART, a separate Enhanced USART that supports LIN specification 1.2, and one Master SSP module capable of both SPI and I²C™ (Master and Slave) modes of operation.
- **CCP Modules:** All devices in the family incorporate two Capture/Compare/PWM (CCP) modules. Up to four different time bases may be used to perform several different operations at once.
- **10-Bit A/D Converter:** This module incorporates programmable acquisition time, allowing for a channel to be selected and a conversion to be initiated without waiting for a sampling period and thus, reducing code overhead.
- **Extended Watchdog Timer (WDT):** This enhanced version incorporates a 16-bit prescaler, allowing an extended time-out range that is stable across operating voltage and temperature. See **Section 25.0 “Electrical Characteristics”** for time-out periods.

1.4 Details on Individual Family Members

Devices in the PIC18F85J90 family are available in 64-pin and 80-pin packages. Block diagrams for the two groups are shown in Figure 1-1 and Figure 1-2.

The devices are differentiated from each other in four ways:

1. Flash program memory (three sizes, ranging from 8 Kbytes for PIC18FX3J90 devices to 32 Kbytes for PIC18FX5J90 devices).
2. Data RAM (1024 bytes for PIC18FX3J90 and PIC18FX4J90 devices, 2048 bytes for PIC18FX5J90 devices).
3. I/O ports (7 bidirectional ports on 64-pin devices, 9 bidirectional ports on 80-pin devices).
4. LCD Pixels: 132 pixels (33 SEGs x 4 COMs) can be driven by 64-pin devices; 192 pixels (48 SEGs x 4 COMs) can be driven by 80-pin devices.

All other features for devices in this family are identical. These are summarized in Table 1-1 and Table 1-2.

The pinouts for all devices are listed in Table 1-3 and Table 1-4.

PIC18F85J90 FAMILY

TABLE 1-1: DEVICE FEATURES FOR THE PIC18F85J90 FAMILY (64-PIN DEVICES)

Features	PIC18F63J90	PIC18F64J90	PIC18F65J90
Operating Frequency	DC – 40 MHz		
Program Memory (Bytes)	8K	16K	32K
Program Memory (Instructions)	4096	8192	16384
Data Memory (Bytes)	1024	1024	2048
Interrupt Sources	27		
I/O Ports	Ports A, B, C, D, E, F, G		
LCD Driver (available pixels to drive)	132 (33 SEGs x 4 COMs)		
Timers	4		
Capture/Compare/PWM Modules	2		
Serial Communications	MSSP, Addressable USART, Enhanced USART		
10-bit Analog-to-Digital Module	12 Input Channels		
Resets (and Delays)	POR, BOR, RESET Instruction, Stack Full, Stack Underflow, MCLR, WDT (PWRT, OST)		
Instruction Set	75 Instructions, 83 with Extended Instruction Set enabled		
Packages	64-pin TQFP		

TABLE 1-2: DEVICE FEATURES FOR THE PIC18F85J90 FAMILY (80-PIN DEVICES)

Features	PIC18F83J90	PIC18F84J90	PIC18F85J90
Operating Frequency	DC – 40 MHz		
Program Memory (Bytes)	8K	16K	32K
Program Memory (Instructions)	4096	8192	16384
Data Memory (Bytes)	1024	1024	2048
Interrupt Sources	27		
I/O Ports	Ports A, B, C, D, E, F, G, H, J		
LCD Driver (available pixels to drive)	192 (48 SEGs x 4 COMs)		
Timers	4		
Capture/Compare/PWM Modules	2		
Serial Communications	MSSP, Addressable USART, Enhanced USART		
10-bit Analog-to-Digital Module	12 Input Channels		
Resets (and Delays)	POR, BOR, RESET Instruction, Stack Full, Stack Underflow, MCLR, WDT (PWRT, OST)		
Instruction Set	75 Instructions, 83 with Extended Instruction Set enabled		
Packages	80-pin TQFP		

PIC18F85J90 FAMILY

FIGURE 1-1: PIC18F6XJ90 (64-PIN) BLOCK DIAGRAM

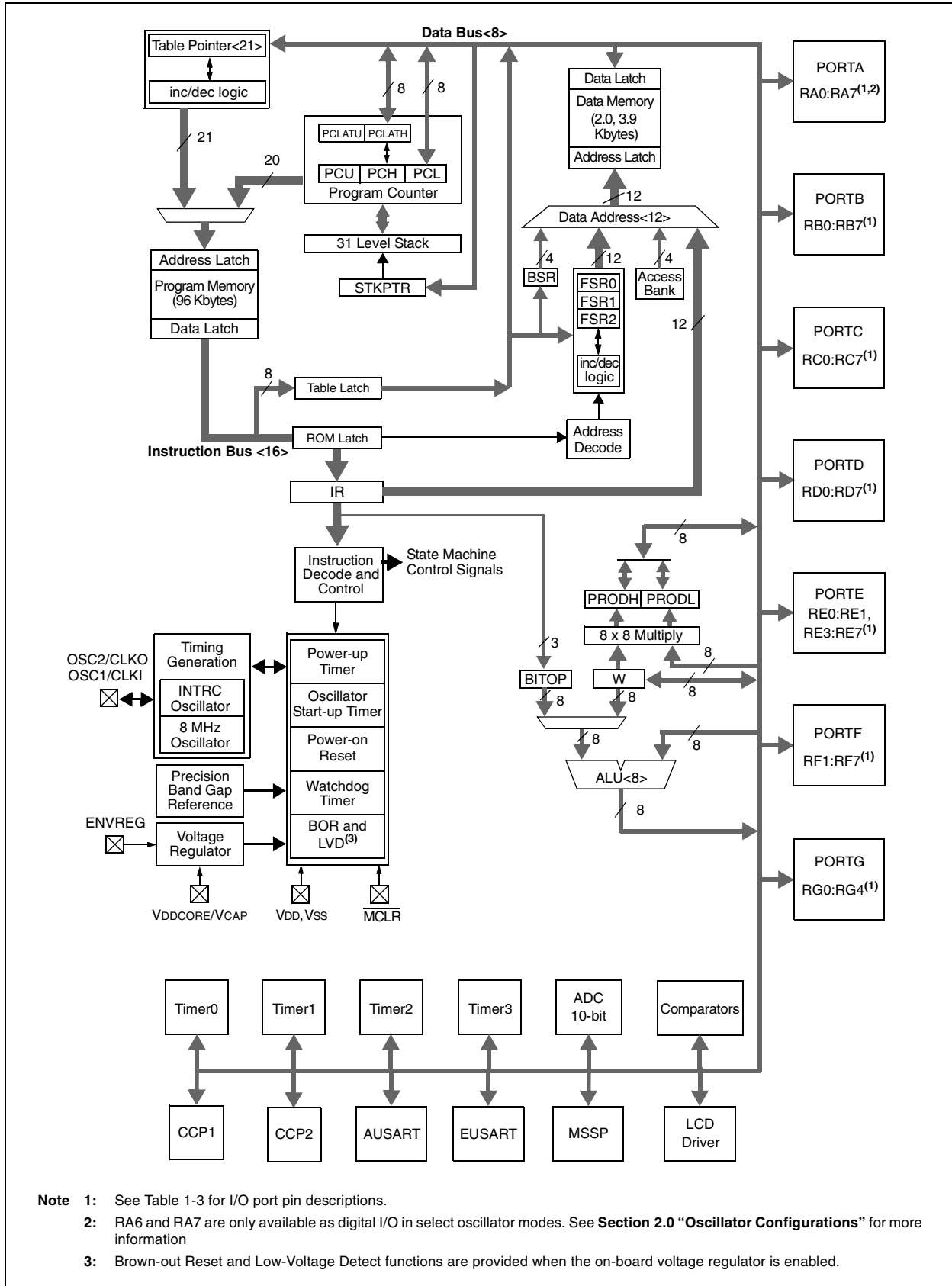

- Note 1:** See Table 1-3 for I/O port pin descriptions.
- Note 2:** RA6 and RA7 are only available as digital I/O in select oscillator modes. See Section 2.0 "Oscillator Configurations" for more information.
- Note 3:** Brown-out Reset and Low-Voltage Detect functions are provided when the on-board voltage regulator is enabled.

PIC18F85J90 FAMILY

FIGURE 1-2: PIC18F8XJ90 (80-PIN) BLOCK DIAGRAM

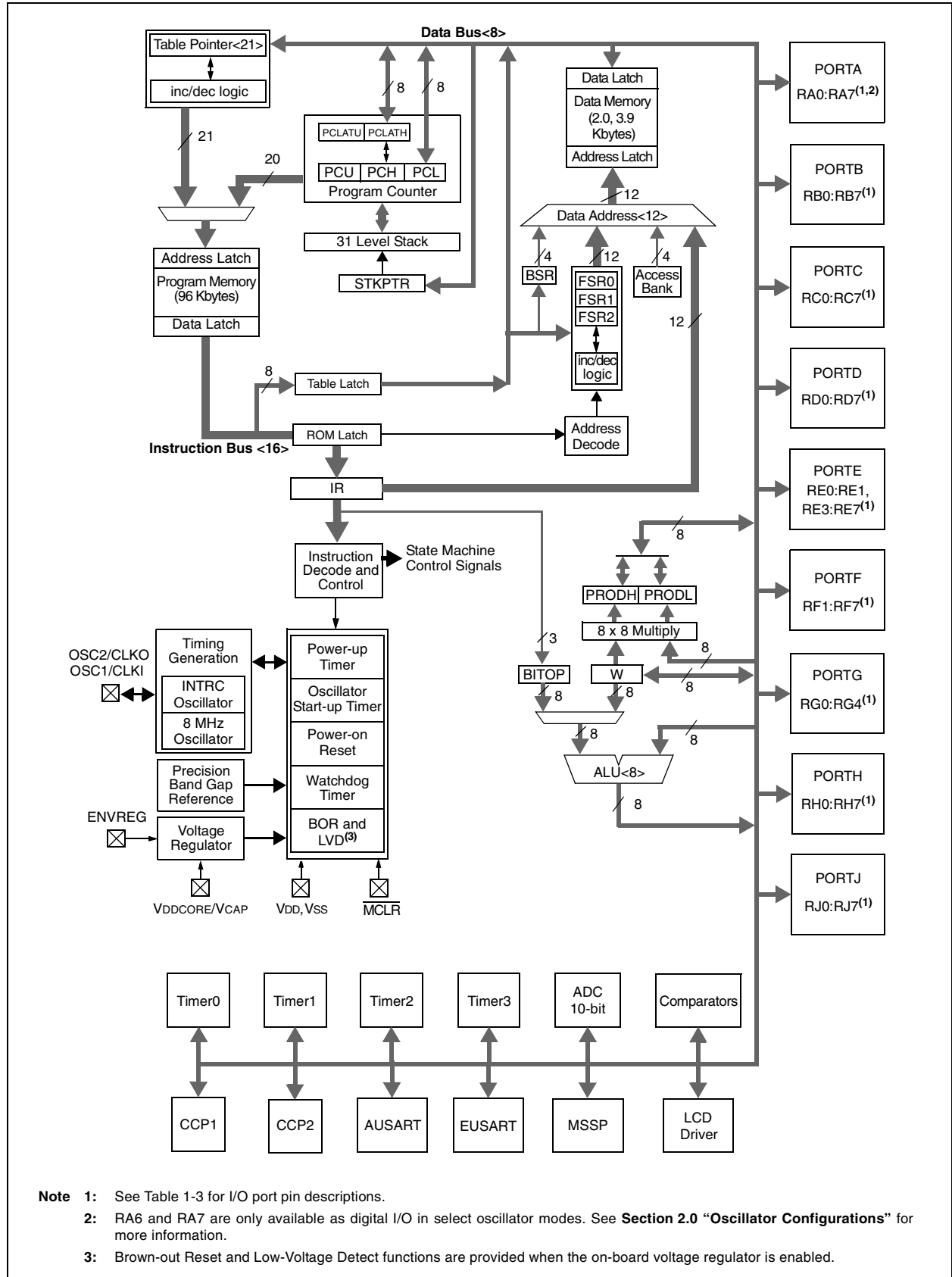

PIC18F85J90 FAMILY

TABLE 1-4: PIC18F8XJ90 PINOUT I/O DESCRIPTIONS (CONTINUED)

Pin Name	Pin Number	Pin Type	Buffer Type	Description
	TQFP			
RE0/LCDBIAS1 RE0 LCDBIAS1	4	I/O I	ST Analog	<p>PORTE is a bidirectional I/O port.</p> <p>Digital I/O. BIAS1 input for LCD.</p>
RE1/LCDBIAS2 RE1 LCDBIAS2	3	I/O I	ST Analog	<p>Digital I/O. BIAS2 input for LCD.</p>
LCDBIAS3	78	I	Analog	BIAS3 input for LCD.
RE3/COM0 RE3 COM0	77	I/O O	ST Analog	<p>Digital I/O. COM0 output for LCD.</p>
RE4/COM1 RE4 COM1	76	I/O O	ST Analog	<p>Digital I/O. COM1 output for LCD.</p>
RE5/COM2 RE5 COM2	75	I/O O	ST Analog	<p>Digital I/O. COM2 output for LCD.</p>
RE6/COM3 RE6 COM3	74	I/O O	ST Analog	<p>Digital I/O. COM3 output for LCD.</p>
RE7/CCP2/SEG31 RE7 CCP2 ⁽²⁾ SEG31	73	I/O I/O O	ST ST Analog	<p>Digital I/O. Capture 2 input/Compare 2 output/PWM 2 output. SEG31 output for LCD.</p>

Legend: TTL = TTL compatible input CMOS = CMOS compatible input or output
 ST = Schmitt Trigger input with CMOS levels Analog = Analog input
 I = Input O = Output
 P = Power OD = Open-Drain (no P diode to VDD)

Note 1: Default assignment for CCP2 when CCP2MX Configuration bit is set.
2: Alternate assignment for CCP2 when CCP2MX Configuration bit is cleared.

PIC18F85J90 FAMILY

NOTES:

PIC18F85J90 FAMILY

2.0 OSCILLATOR CONFIGURATIONS

2.1 Oscillator Types

The PIC18F85J90 family of devices can be operated in six different oscillator modes:

1. HS High-Speed Crystal/Resonator
2. HSPLL High-Speed Crystal/Resonator with Software PLL Control
3. EC External Clock with Fosc/4 Output
4. ECPLL External Clock with Software PLL Control
5. INTOSC Internal Fast RC (8 MHz) oscillator
6. INTRC Internal 31 kHz Oscillator

Five of these are selected by the user by programming the FOSC2:FOSC0 Configuration bits. The sixth mode (INTRC) may be invoked under software control; it can also be configured as the default mode on device Resets.

In addition, PIC18F85J90 family devices can switch between different clock sources, either under software control, or automatically under certain conditions. This allows for additional power savings by managing device clock speed in real time without resetting the application.

The clock sources for the PIC18F85J90 family of devices are shown in Figure 2-1.

FIGURE 2-1: PIC18F85J90 FAMILY CLOCK DIAGRAM

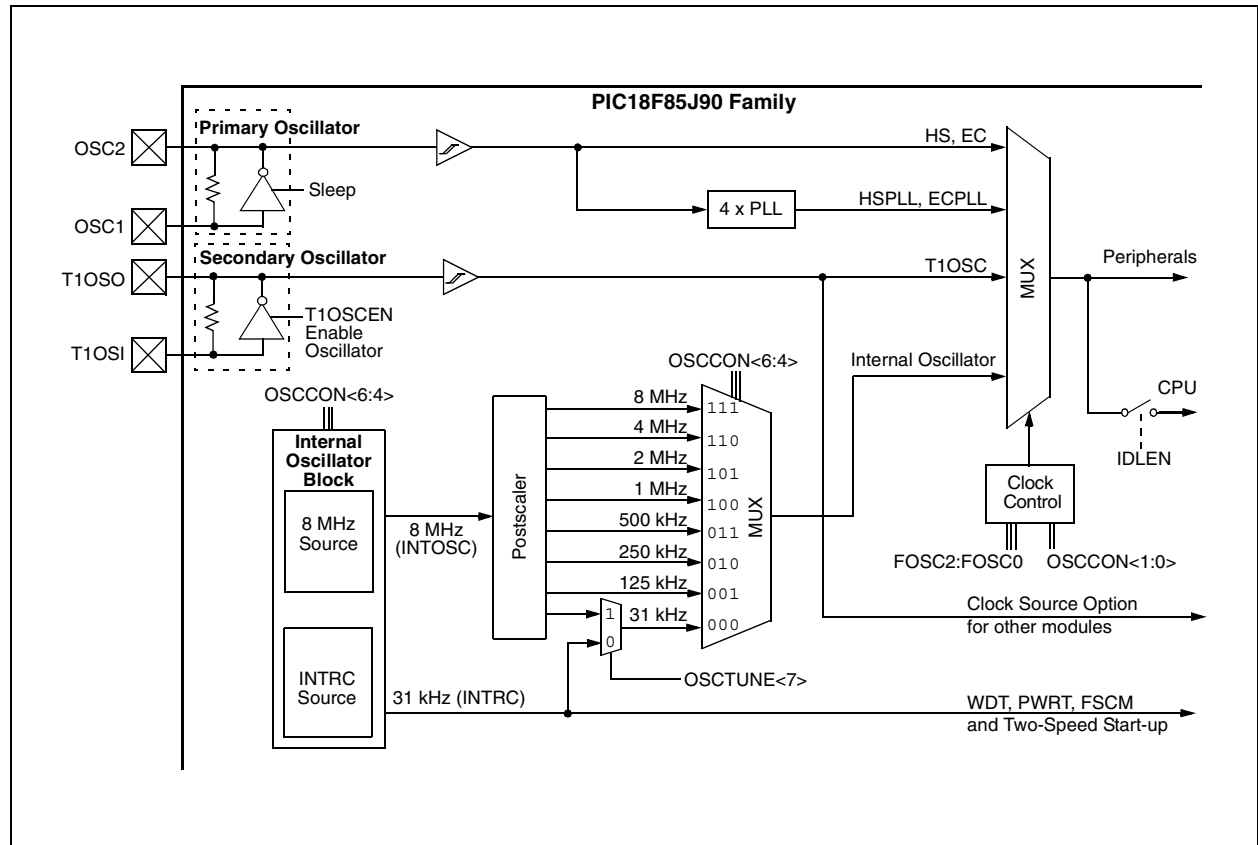

PIC18F85J90 FAMILY

2.2 Control Registers

The OSCCON register (Register 2-1) controls the main aspects of the device clock's operation. It selects the oscillator type to be used, which of the power-managed modes to invoke and the output frequency of the INTOSC source. It also provides status on the oscillators.

The OSCTUNE register (Register 2-2) controls the tuning and operation of the internal oscillator block. It also implements the PLEN bits, which control the operation of the Phase Locked Loop (PLL) in Internal Oscillator modes (see **Section 2.4.3 "PLL Frequency Multiplier"**).

REGISTER 2-1: OSCCON: OSCILLATOR CONTROL REGISTER

R/W-0	R/W-1	R/W-0	R/W-0	R ⁽¹⁾	R-0	R/W-0	R/W-0
IDLEN	IRCF2	IRCF1	IRCF0	OSTS	IOFS	SCS1	SCS0
bit 7							bit 0

Legend:			
R = Readable bit	W = Writable bit	U = Unimplemented bit, read as '0'	
-n = Value at POR	'1' = Bit is set	'0' = Bit is cleared	x = Bit is unknown

- bit 7 **IDLEN:** Idle Enable bit
 - 1 = Device enters an Idle mode when a SLEEP instruction is executed
 - 0 = Device enters Sleep mode when a SLEEP instruction is executed
- bit 6-4 **IRCF2:IRCF0:** INTOSC Source Frequency Select bits⁽²⁾
 - 111 = 8 MHz (INTOSC drives clock directly)
 - 110 = 4 MHz
 - 101 = 2 MHz
 - 100 = 1 MHz (default)
 - 011 = 500 kHz
 - 010 = 250 kHz
 - 001 = 125 kHz
 - 000 = 31 kHz (from either INTOSC/256 or INTRC)⁽³⁾
- bit 3 **OSTS:** Oscillator Start-up Time-out Status bit⁽¹⁾
 - 1 = Oscillator Start-up Timer (OST) time-out has expired; primary oscillator is running
 - 0 = Oscillator Start-up Timer (OST) time-out is running; primary oscillator is not ready
- bit 2 **IOFS:** INTOSC Frequency Stable bit
 - 1 = Fast RC oscillator frequency is stable
 - 0 = Fast RC oscillator frequency is not stable
- bit 1-0 **SCS1:SCS0:** System Clock Select bits⁽⁴⁾
 - 11 = Internal oscillator block
 - 10 = Primary oscillator
 - 01 = Timer1 oscillator
 - When FOSC2 = 1:
 - 00 = Primary oscillator
 - When FOSC2 = 0:
 - 00 = Internal oscillator

- Note 1:** Reset state depends on state of the IESO Configuration bit.
- 2:** Modifying these bits will cause an immediate clock frequency switch if the internal oscillator is providing the device clocks.
- 3:** Source selected by the INTSRC bit (OSCTUNE<7>), see text.
- 4:** Modifying these bits will cause an immediate clock source switch.

PIC18F85J90 FAMILY

2.3.1 CLOCK SOURCE SELECTION

The System Clock Select bits, SCS1:SCS0 (OSCCON<1:0>), select the clock source. The available clock sources are the primary clock defined by the FOSC1:FOSC0 Configuration bits, the secondary clock (Timer1 oscillator) and the internal oscillator. The clock source changes after one or more of the bits are written to, following a brief clock transition interval.

The OSTS (OSCCON<3>) and T1RUN (T1CON<6>) bits indicate which clock source is currently providing the device clock. The OSTS bit indicates that the Oscillator Start-up Timer (OST) has timed out and the primary clock is providing the device clock in primary clock modes. The T1RUN bit indicates when the Timer1 oscillator is providing the device clock in secondary clock modes. In power-managed modes, only one of these bits will be set at any time. If neither of these bits are set, the INTRC is providing the clock, or the internal oscillator has just started and is not yet stable.

The IDLEN bit determines if the device goes into Sleep mode or one of the Idle modes when the SLEEP instruction is executed.

The use of the flag and control bits in the OSCCON register is discussed in more detail in **Section 3.0 “Power-Managed Modes”**.

Note 1: The Timer1 oscillator must be enabled to select the secondary clock source. The Timer1 oscillator is enabled by setting the T1OSCEN bit in the Timer1 Control register (T1CON<3>). If the Timer1 oscillator is not enabled, then any attempt to select a secondary clock source when executing a SLEEP instruction will be ignored.

2: It is recommended that the Timer1 oscillator be operating and stable before executing the SLEEP instruction or a very long delay may occur while the Timer1 oscillator starts.

2.3.1.1 System Clock Selection and the FOSC2 Configuration Bit

The SCS bits are cleared on all forms of Reset. In the device's default configuration, this means the primary oscillator defined by FOSC1:FOSC0 (that is, one of the HS or EC modes) is used as the primary clock source on device Resets.

The default clock configuration on Reset can be changed with the FOSC2 Configuration bit. This bit determines whether the external or internal oscillator will be the default clock source on subsequent device Resets. By extension, it also has the effect of determining the clock source selected when SCS1:SCS0 are in their Reset state (= 00). When FOSC2 = 1 (default), the oscillator source defined by FOSC1:FOSC0 is selected whenever SCS1:SCS0 = 00. When FOSC2 = 0, the internal oscillator block is selected whenever SCS1:SCS2 = 00.

In those cases when the internal oscillator block is the default clock on Reset, the Fast RC oscillator (INTOSC) will be used as the device clock source. It will initially start at 1 MHz, the postscaler selection that corresponds to the Reset value of the IRCF2:IRCF0 bits ('100').

Regardless of the setting of FOSC2, INTRC will always be enabled on device power-up. It serves as the clock source until the device has loaded its configuration values from memory. It is at this point that the FOSC Configuration bits are read and the oscillator selection of the operational mode is made.

Note that either the primary clock or the internal oscillator will have two bit setting options for the possible values of SCS1:SCS0, at any given time, depending on the setting of FOSC2.

2.3.2 OSCILLATOR TRANSITIONS

PIC18F85J90 family devices contain circuitry to prevent clock “glitches” when switching between clock sources. A short pause in the device clock occurs during the clock switch. The length of this pause is the sum of two cycles of the old clock source and three to four cycles of the new clock source. This formula assumes that the new clock source is stable.

Clock transitions are discussed in greater detail in **Section 3.1.2 “Entering Power-Managed Modes”**.

PIC18F85J90 FAMILY

2.4 External Oscillator Modes

2.4.1 CRYSTAL OSCILLATOR/CERAMIC RESONATORS (HS MODES)

In HS or HSPLL Oscillator modes, a crystal or ceramic resonator is connected to the OSC1 and OSC2 pins to establish oscillation. Figure 2-2 shows the pin connections.

The oscillator design requires the use of a parallel cut crystal.

Note: Use of a series cut crystal may give a frequency out of the crystal manufacturer's specifications.

TABLE 2-1: CAPACITOR SELECTION FOR CERAMIC RESONATORS

Typical Capacitor Values Used:			
Mode	Freq.	OSC1	OSC2
HS	8.0 MHz	27 pF	27 pF
	16.0 MHz	22 pF	22 pF

Capacitor values are for design guidance only.

Different capacitor values may be required to produce acceptable oscillator operation. The user should test the performance of the oscillator over the expected VDD and temperature range for the application. Refer to the following application notes for oscillator specific information:

- AN588, "PIC® Microcontroller Oscillator Design Guide"
- AN826, "Crystal Oscillator Basics and Crystal Selection for rfPIC® and PIC® Devices"
- AN849, "Basic PIC® Oscillator Design"
- AN943, "Practical PIC® Oscillator Analysis and Design"
- AN949, "Making Your Oscillator Work"

See the notes following Table 2-2 for additional information.

TABLE 2-2: CAPACITOR SELECTION FOR CRYSTAL OSCILLATOR

Osc Type	Crystal Freq.	Typical Capacitor Values Tested:	
		C1	C2
HS	4 MHz	27 pF	27 pF
	8 MHz	22 pF	22 pF
	20 MHz	15 pF	15 pF

Capacitor values are for design guidance only.

Different capacitor values may be required to produce acceptable oscillator operation. The user should test the performance of the oscillator over the expected VDD and temperature range for the application.

Refer to the Microchip application notes cited in Table 2-1 for oscillator specific information. Also see the notes following this table for additional information.

Note 1: Higher capacitance increases the stability of oscillator but also increases the start-up time.

2: Since each resonator/crystal has its own characteristics, the user should consult the resonator/crystal manufacturer for appropriate values of external components.

3: Rs may be required to avoid overdriving crystals with low drive level specification.

4: Always verify oscillator performance over the VDD and temperature range that is expected for the application.

FIGURE 2-2: CRYSTAL/CERAMIC RESONATOR OPERATION (HS OR HSPLL CONFIGURATION)

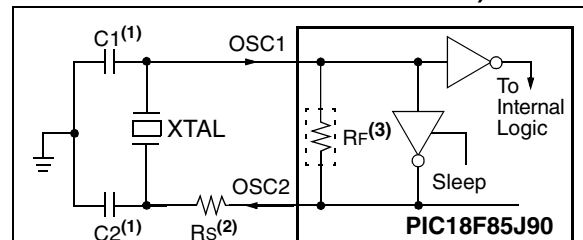

Note 1: See Table 2-1 and Table 2-2 for initial values of C1 and C2.

2: A series resistor (Rs) may be required for AT strip cut crystals.

3: RF varies with the oscillator mode chosen.

PIC18F85J90 FAMILY

2.4.2 EXTERNAL CLOCK INPUT (EC MODES)

The EC and ECPLL Oscillator modes require an external clock source to be connected to the OSC1 pin. There is no oscillator start-up time required after a Power-on Reset or after an exit from Sleep mode.

In the EC Oscillator mode, the oscillator frequency divided by 4 is available on the OSC2 pin. This signal may be used for test purposes or to synchronize other logic. Figure 2-3 shows the pin connections for the EC Oscillator mode.

FIGURE 2-3: EXTERNAL CLOCK INPUT OPERATION (EC CONFIGURATION)

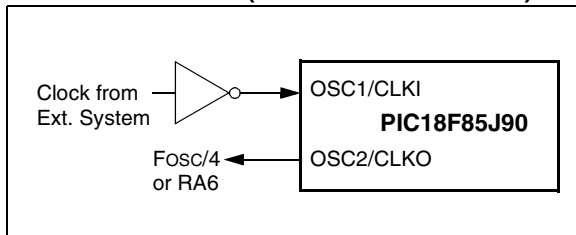

An external clock source may also be connected to the OSC1 pin in the HS mode, as shown in Figure 2-4. In this configuration, the divide-by-4 output on OSC2 is not available.

FIGURE 2-4: EXTERNAL CLOCK INPUT OPERATION (HS OSC CONFIGURATION)

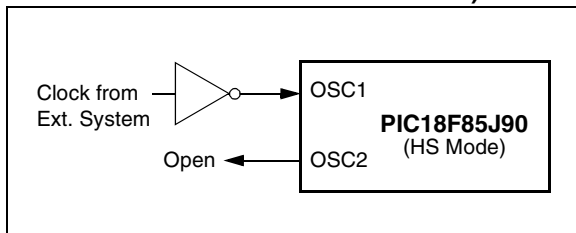

2.4.3 PLL FREQUENCY MULTIPLIER

A Phase Locked Loop (PLL) circuit is provided as an option for users who want to use a lower frequency oscillator circuit, or to clock the device up to its highest rated frequency from a crystal oscillator. This may be useful for customers who are concerned with EMI due to high-frequency crystals, or users who require higher clock speeds from an internal oscillator. For these reasons, the HSPLL and ECPLL modes are available.

The HSPLL and ECPLL modes provide the ability to selectively run the device at 4 times the external oscillating source to produce frequencies up to 40 MHz. The PLL is enabled by programming the FOSC2:FOSC0 Configuration bits (CONFIG2L<2:0>) to either '110' (for ECPLL) or '100' (for HSPLL). In addition, the PLEN bit (OSCTUNE<6>) must also be set. Clearing PLEN disables the PLL, regardless of the chosen oscillator configuration. It also allows additional flexibility for controlling the application's clock speed in software.

FIGURE 2-5: PLL BLOCK DIAGRAM

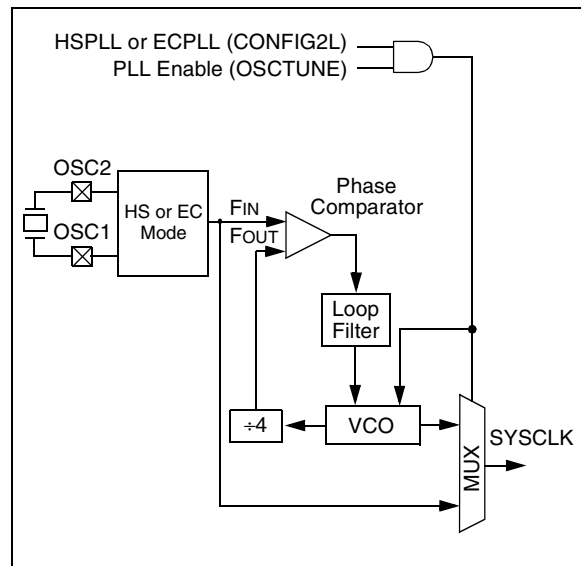

2.5 Internal Oscillator Block

The PIC18F85J90 family of devices includes an internal oscillator block which generates two different clock signals; either can be used as the microcontroller's clock source. This may eliminate the need for an external oscillator circuit on the OSC1 and/or OSC2 pins.

The main output is the Fast RC oscillator, or INTOSC, an 8 MHz clock source which can be used to directly drive the device clock. It also drives a postscaler, which can provide a range of clock frequencies from 31 kHz to 4 MHz. INTOSC is enabled when a clock frequency from 125 kHz to 8 MHz is selected. The INTOSC output can also be enabled when 31 kHz is selected, depending on the INTSRC bit (OSCTUNE<7>).

The other clock source is the Internal RC oscillator (INTRC), which provides a nominal 31 kHz output. INTRC is enabled if it is selected as the device clock source. It is also enabled automatically when any of the following are enabled:

- Power-up Timer
- Fail-Safe Clock Monitor
- Watchdog Timer
- Two-Speed Start-up

These features are discussed in greater detail in **Section 22.0 "Special Features of the CPU"**.

The clock source frequency (INTOSC direct, INTOSC with postscaler or INTRC direct) is selected by configuring the IRCF bits of the OSCCON register. The default frequency on device Resets is 1 MHz.

2.5.1 OSC1 AND OSC2 PIN CONFIGURATION

Whenever the internal oscillator is configured as the default clock source (FOSC2 = 0), the OSC1 and OSC2 pins are reconfigured automatically as port pins, RA6 and RA7. In this mode, they function as general digital I/O. All oscillator functions on the pins are disabled.

2.5.2 INTERNAL OSCILLATOR OUTPUT FREQUENCY AND TUNING

The internal oscillator block is calibrated at the factory to produce an INTOSC output frequency of 8 MHz. It can be adjusted in the user's application by writing to TUN5:TUN0 (OSCTUNE<5:0>) in the OSCTUNE register (Register 2-2).

When the OSCTUNE register is modified, the INTOSC frequency will begin shifting to the new frequency. The oscillator will stabilize within 1 ms. Code execution continues during this shift. There is no indication that the shift has occurred.

The INTRC oscillator operates independently of the INTOSC source. Any changes in INTOSC across voltage and temperature are not necessarily reflected by changes in INTRC or vice versa. The frequency of INTRC is not affected by OSCTUNE.

2.5.3 INTOSC FREQUENCY DRIFT

The INTOSC frequency may drift as VDD or temperature changes, and can affect the controller operation in a variety of ways. It is possible to adjust the INTOSC frequency by modifying the value in the OSCTUNE register. This will have no effect on the INTRC clock source frequency.

Tuning INTOSC requires knowing when to make the adjustment, in which direction it should be made and in some cases, how large a change is needed. Three compensation techniques are shown here.

2.5.3.1 Compensating with the EUSART

An adjustment may be required when the EUSART begins to generate framing errors or receives data with errors while in Asynchronous mode. Framing errors indicate that the device clock frequency is too high. To adjust for this, decrement the value in OSCTUNE to reduce the clock frequency. On the other hand, errors in data may suggest that the clock speed is too low. To compensate, increment OSCTUNE to increase the clock frequency.

2.5.3.2 Compensating with the Timers

This technique compares device clock speed to some reference clock. Two timers may be used; one timer is clocked by the peripheral clock, while the other is clocked by a fixed reference source, such as the Timer1 oscillator.

Both timers are cleared, but the timer clocked by the reference generates interrupts. When an interrupt occurs, the internally clocked timer is read and both timers are cleared. If the internally clocked timer value is much greater than expected, then the internal oscillator block is running too fast. To adjust for this, decrement the OSCTUNE register.

2.5.3.3 Compensating with the CCP Module in Capture Mode

A CCP module can use free-running Timer1 (or Timer3), clocked by the internal oscillator block and an external event with a known period (i.e., AC power frequency). The time of the first event is captured in the CCPxH:CCPxL registers and is recorded for use later. When the second event causes a capture, the time of the first event is subtracted from the time of the second event. Since the period of the external event is known, the time difference between events can be calculated.

If the measured time is much greater than the calculated time, the internal oscillator block is running too fast. To compensate, decrement the OSCTUNE register. If the measured time is much less than the calculated time, the internal oscillator block is running too slow. To compensate, increment the OSCTUNE register.

PIC18F85J90 FAMILY

2.6 Effects of Power-Managed Modes on the Various Clock Sources

When PRI_IDLE mode is selected, the designated primary oscillator continues to run without interruption. For all other power-managed modes, the oscillator using the OSC1 pin is disabled. The OSC1 pin (and OSC2 pin if used by the oscillator) will stop oscillating.

In secondary clock modes (SEC_RUN and SEC_IDLE), the Timer1 oscillator is operating and providing the device clock. The Timer1 oscillator may also run in all power-managed modes if required to clock Timer1 or Timer3.

In RC_RUN and RC_IDLE modes, the internal oscillator provides the device clock source. The 31 kHz INTRC output can be used directly to provide the clock and may be enabled to support various special features, regardless of the power-managed mode (see **Section 22.2 “Watchdog Timer (WDT)”** through **Section 22.5 “Fail-Safe Clock Monitor”** for more information on WDT, Fail-Safe Clock Monitor and Two-Speed Start-up).

If the Sleep mode is selected, all clock sources are stopped. Since all the transistor switching currents have been stopped, Sleep mode achieves the lowest current consumption of the device (only leakage currents).

Enabling any on-chip feature that will operate during Sleep will increase the current consumed during Sleep. The INTRC is required to support WDT operation. The

Timer1 oscillator may be operating to support a Real-Time Clock. Other features may be operating that do not require a device clock source (i.e., MSSP slave, PSP, INTn pins and others). Peripherals that may add significant current consumption are listed in **Section 25.2 “DC Characteristics: Power-Down and Supply Current”**.

2.7 Power-up Delays

Power-up delays are controlled by two timers, so that no external Reset circuitry is required for most applications. The delays ensure that the device is kept in Reset until the device power supply is stable under normal circumstances and the primary clock is operating and stable. For additional information on power-up delays, see **Section 4.5 “Power-up Timer (PWRT)”**.

The first timer is the Power-up Timer (PWRT), which provides a fixed delay on power-up (parameter 33, Table 25-11). It is always enabled.

The second timer is the Oscillator Start-up Timer (OST), intended to keep the chip in Reset until the crystal oscillator is stable (HS modes). The OST does this by counting 1024 oscillator cycles before allowing the oscillator to clock the device.

There is a delay of interval TCSD (parameter 38, Table 25-11), following POR, while the controller becomes ready to execute instructions.

TABLE 2-3: OSC1 AND OSC2 PIN STATES IN SLEEP MODE

Oscillator Mode	OSC1 Pin	OSC2 Pin
EC, ECPLL	Floating, pulled by external clock	At logic low (clock/4 output)
HS, HSPLL	Feedback inverter disabled at quiescent voltage level	Feedback inverter disabled at quiescent voltage level
INTOSC	I/O pin RA6, direction controlled by TRISA<6>	I/O pin RA7, direction controlled by TRISA<7>

Note: See Table 4-2 in **Section 4.0 “Reset”** for time-outs due to Sleep and MCLR Reset.

3.0 POWER-MANAGED MODES

The PIC18F85J90 family devices provide the ability to manage power consumption by simply managing clocking to the CPU and the peripherals. In general, a lower clock frequency and a reduction in the number of circuits being clocked constitutes lower consumed power. For the sake of managing power in an application, there are three primary modes of operation:

- Run mode
- Idle mode
- Sleep mode

These modes define which portions of the device are clocked and at what speed. The Run and Idle modes may use any of the three available clock sources (primary, secondary or internal oscillator block); the Sleep mode does not use a clock source.

The power-managed modes include several power-saving features offered on previous PIC® devices. One is the clock switching feature, offered in other PIC18 devices, allowing the controller to use the Timer1 oscillator in place of the primary oscillator. Also included is the Sleep mode, offered by all PIC devices, where all device clocks are stopped.

3.1 Selecting Power-Managed Modes

Selecting a power-managed mode requires two decisions: if the CPU is to be clocked or not and which clock source is to be used. The IDLEN bit (OSCCON<7>) controls CPU clocking, while the SCS1:SCS0 bits (OSCCON<1:0>) select the clock source. The individual modes, bit settings, clock sources and affected modules are summarized in Table 3-1.

TABLE 3-1: POWER-MANAGED MODES

Mode	OSCCON bits		Module Clocking		Available Clock and Oscillator Source
	IDLEN<7> ⁽¹⁾	SCS1:SCS0<1:0>	CPU	Peripherals	
Sleep	0	N/A	Off	Off	None – All clocks are disabled
PRI_RUN	N/A	10	Clocked	Clocked	Primary – HS, EC, HSPLL, ECPLL; this is the normal full power execution mode
SEC_RUN	N/A	01	Clocked	Clocked	Secondary – Timer1 Oscillator
RC_RUN	N/A	11	Clocked	Clocked	Internal Oscillator
PRI_IDLE	1	10	Off	Clocked	Primary – HS, EC, HSPLL, ECPLL
SEC_IDLE	1	01	Off	Clocked	Secondary – Timer1 Oscillator
RC_IDLE	1	11	Off	Clocked	Internal Oscillator

Note 1: IDLEN reflects its value when the SLEEP instruction is executed.

3.1.1 CLOCK SOURCES

The SCS1:SCS0 bits allow the selection of one of three clock sources for power-managed modes. They are:

- the primary clock, as defined by the FOSC2:FOSC0 Configuration bits
- the secondary clock (Timer1 oscillator)
- the internal oscillator

3.1.2 ENTERING POWER-MANAGED MODES

Switching from one power-managed mode to another begins by loading the OSCCON register. The SCS1:SCS0 bits select the clock source and determine which Run or Idle mode is to be used. Changing these bits causes an immediate switch to the new clock source, assuming that it is running. The switch may also be subject to clock transition delays. These are discussed in **Section 3.1.3 “Clock Transitions and Status Indicators”** and subsequent sections.

Entry to the power-managed Idle or Sleep modes is triggered by the execution of a SLEEP instruction. The actual mode that results depends on the status of the IDLEN bit.

Depending on the current mode and the mode being switched to, a change to a power-managed mode does not always require setting all of these bits. Many transitions may be done by changing the oscillator select bits, or changing the IDLEN bit, prior to issuing a SLEEP instruction. If the IDLEN bit is already configured correctly, it may only be necessary to perform a SLEEP instruction to switch to the desired mode.

PIC18F85J90 FAMILY

3.1.3 CLOCK TRANSITIONS AND STATUS INDICATORS

The length of the transition between clock sources is the sum of two cycles of the old clock source and three to four cycles of the new clock source. This formula assumes that the new clock source is stable.

Two bits indicate the current clock source and its status: OSTS (OSCCON<3>) and T1RUN (T1CON<6>). In general, only one of these bits will be set while in a given power-managed mode. When the OSTS bit is set, the primary clock is providing the device clock. When the T1RUN bit is set, the Timer1 oscillator is providing the clock. If neither of these bits is set, INTRC is clocking the device.

<p>Note: Executing a SLEEP instruction does not necessarily place the device into Sleep mode. It acts as the trigger to place the controller into either the Sleep mode, or one of the Idle modes, depending on the setting of the IDLEN bit.</p>

3.1.4 MULTIPLE SLEEP COMMANDS

The power-managed mode that is invoked with the SLEEP instruction is determined by the setting of the IDLEN bit at the time the instruction is executed. If another SLEEP instruction is executed, the device will enter the power-managed mode specified by IDLEN at that time. If IDLEN has changed, the device will enter the new power-managed mode specified by the new setting.

3.2 Run Modes

In the Run modes, clocks to both the core and peripherals are active. The difference between these modes is the clock source.

3.2.1 PRI_RUN MODE

The PRI_RUN mode is the normal, full power execution mode of the microcontroller. This is also the default mode upon a device Reset unless Two-Speed Start-up is enabled (see **Section 22.4 “Two-Speed Start-up”** for details). In this mode, the OSTS bit is set (see **Section 2.2 “Control Registers”**).

3.2.2 SEC_RUN MODE

The SEC_RUN mode is the compatible mode to the “clock switching” feature offered in other PIC18 devices. In this mode, the CPU and peripherals are clocked from the Timer1 oscillator. This gives users the option of lower power consumption while still using a high-accuracy clock source.

SEC_RUN mode is entered by setting the SCS1:SCS0 bits to ‘01’. The device clock source is switched to the Timer1 oscillator (see Figure 3-1), the primary oscillator is shut down, the T1RUN bit (T1CON<6>) is set and the OSTS bit is cleared.

PIC18F85J90 FAMILY

Note: The Timer1 oscillator should already be running prior to entering SEC_RUN mode. If the T1OSCN bit is not set when the SCS1:SCS0 bits are set to '01', entry to SEC_RUN mode will not occur. If the Timer1 oscillator is enabled, but not yet running, device clocks will be delayed until the oscillator has started. In such situations, initial oscillator operation is far from stable and unpredictable operation may result.

On transitions from SEC_RUN mode to PRI_RUN mode, the peripherals and CPU continue to be clocked from the Timer1 oscillator while the primary clock is started. When the primary clock becomes ready, a clock switch back to the primary clock occurs (see Figure 3-2). When the clock switch is complete, the T1RUN bit is cleared, the OSTS bit is set and the primary clock is providing the clock. The IDLEN and SCS bits are not affected by the wake-up; the Timer1 oscillator continues to run.

FIGURE 3-1: TRANSITION TIMING FOR ENTRY TO SEC_RUN MODE

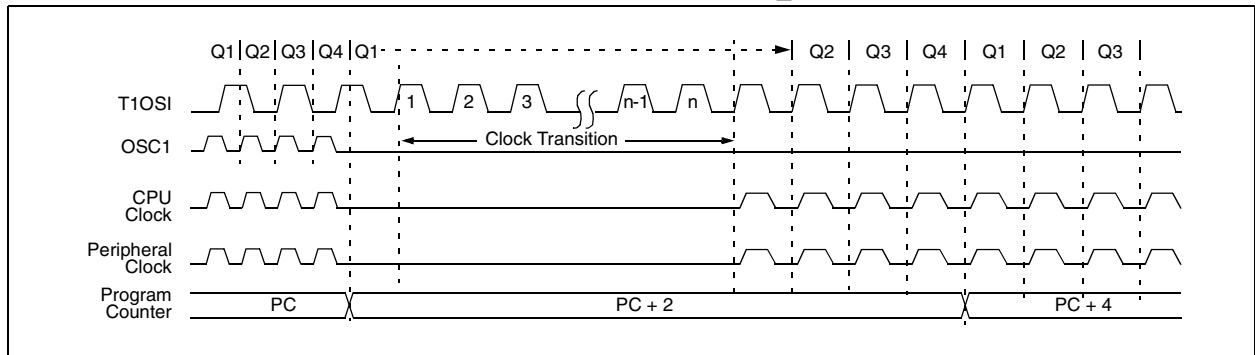
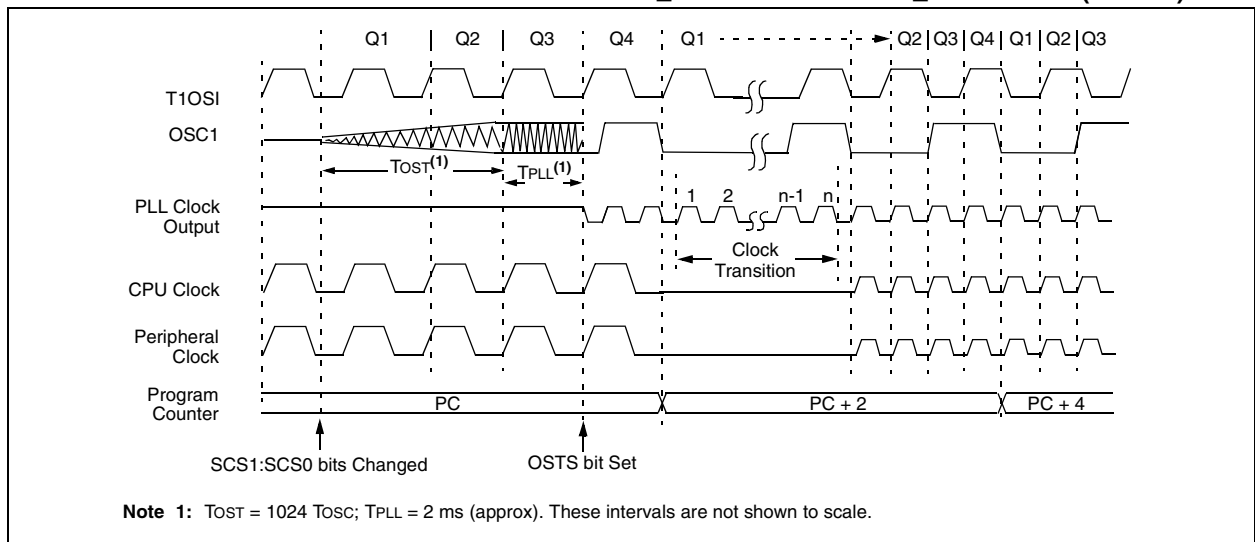

FIGURE 3-2: TRANSITION TIMING FROM SEC_RUN MODE TO PRI_RUN MODE (HSPLL)



PIC18F85J90 FAMILY

3.2.3 RC_RUN MODE

In RC_RUN mode, the CPU and peripherals are clocked from the internal oscillator; the primary clock is shut down. This mode provides the best power conservation of all the Run modes while still executing code. It works well for user applications which are not highly timing sensitive or do not require high-speed clocks at all times.

This mode is entered by setting SCS bits to '11'. When the clock source is switched to the INTRC (see Figure 3-3), the primary oscillator is shut down and the OSTS bit is cleared.

On transitions from RC_RUN mode to PRI_RUN mode, the device continues to be clocked from the INTRC while the primary clock is started. When the primary clock becomes ready, a clock switch to the primary clock occurs (see Figure 3-4). When the clock switch is complete, the OSTS bit is set and the primary clock is providing the device clock. The IDLEN and SCS bits are not affected by the switch. The INTRC source will continue to run if either the WDT or the Fail-Safe Clock Monitor is enabled.

FIGURE 3-3: TRANSITION TIMING TO RC_RUN MODE

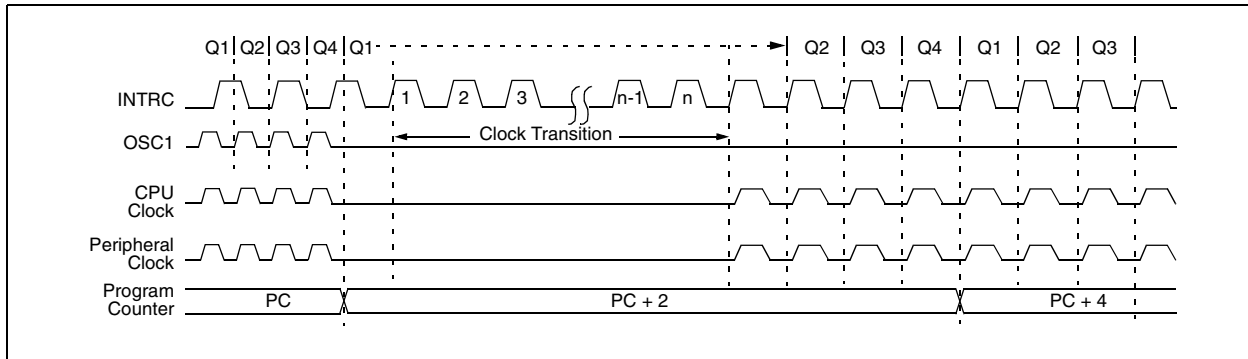
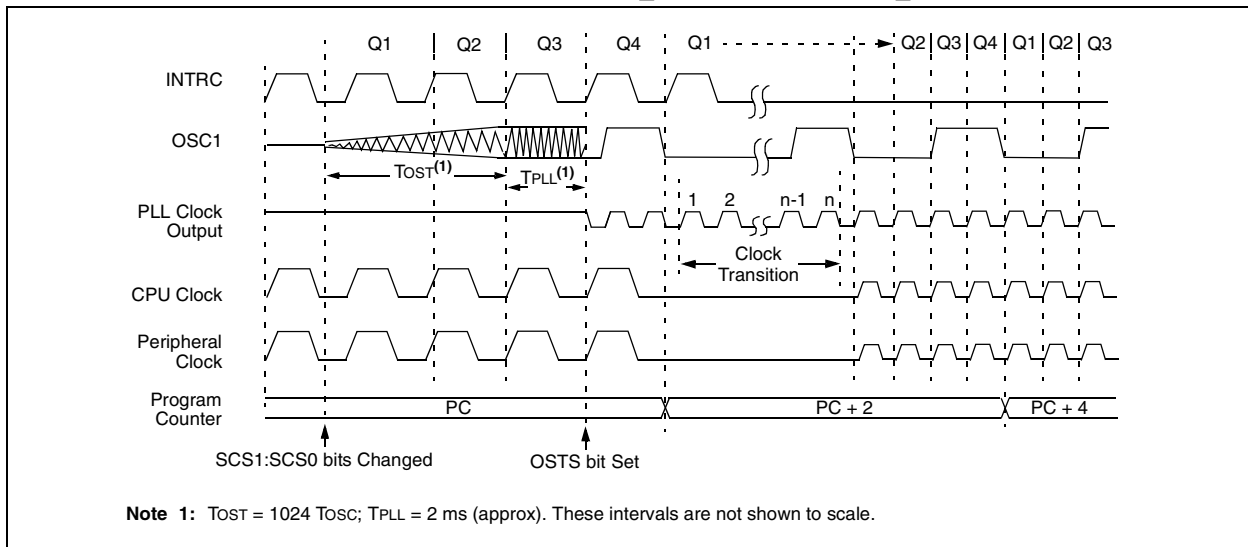

FIGURE 3-4: TRANSITION TIMING FROM RC_RUN MODE TO PRI_RUN MODE



3.3 Sleep Mode

The power-managed Sleep mode is identical to the legacy Sleep mode offered in all other PIC devices. It is entered by clearing the IDLEN bit (the default state on device Reset) and executing the `SLEEP` instruction. This shuts down the selected oscillator (Figure 3-5). All clock source status bits are cleared.

Entering the Sleep mode from any other mode does not require a clock switch. This is because no clocks are needed once the controller has entered Sleep. If the WDT is selected, the INTRC source will continue to operate. If the Timer1 oscillator is enabled, it will also continue to run.

When a wake event occurs in Sleep mode (by interrupt, Reset or WDT time-out), the device will not be clocked until the clock source selected by the SCS1:SCS0 bits becomes ready (see Figure 3-6), or it will be clocked from the internal oscillator if either the Two-Speed Start-up or the Fail-Safe Clock Monitor are enabled (see Section 22.0 “Special Features of the CPU”). In either case, the OSTS bit is set when the primary clock is providing the device clocks. The IDLEN and SCS bits are not affected by the wake-up.

3.4 Idle Modes

The Idle modes allow the controller’s CPU to be selectively shut down while the peripherals continue to operate. Selecting a particular Idle mode allows users to further manage power consumption.

If the IDLEN bit is set to a ‘1’ when a `SLEEP` instruction is executed, the peripherals will be clocked from the clock source selected using the SCS1:SCS0 bits; however, the CPU will not be clocked. The clock source status bits are not affected. Setting IDLEN and executing a `SLEEP` instruction provides a quick method of switching from a given Run mode to its corresponding Idle mode.

If the WDT is selected, the INTRC source will continue to operate. If the Timer1 oscillator is enabled, it will also continue to run.

Since the CPU is not executing instructions, the only exits from any of the Idle modes are by interrupt, WDT time-out or a Reset. When a wake event occurs, CPU execution is delayed by an interval of T_{CSD} (parameter 38, Table 25-11) while it becomes ready to execute code. When the CPU begins executing code, it resumes with the same clock source for the current Idle mode. For example, when waking from RC_IDLE mode, the internal oscillator block will clock the CPU and peripherals (in other words, RC_RUN mode). The IDLEN and SCS bits are not affected by the wake-up.

While in any Idle mode or the Sleep mode, a WDT time-out will result in a WDT wake-up to the Run mode currently specified by the SCS1:SCS0 bits.

FIGURE 3-5: TRANSITION TIMING FOR ENTRY TO SLEEP MODE

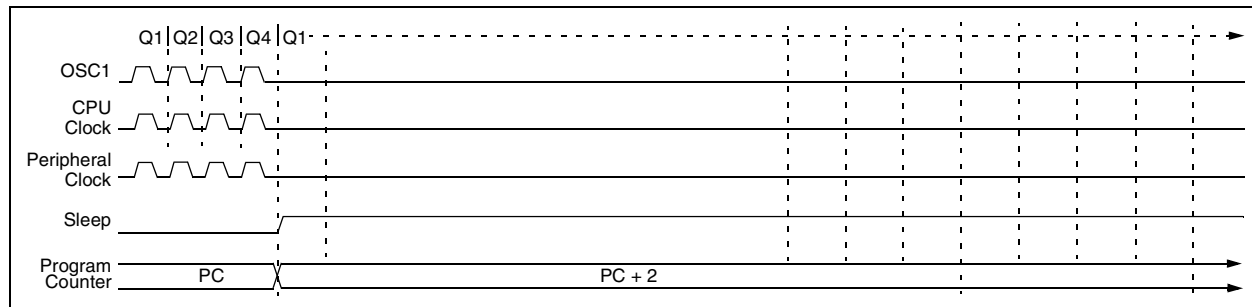
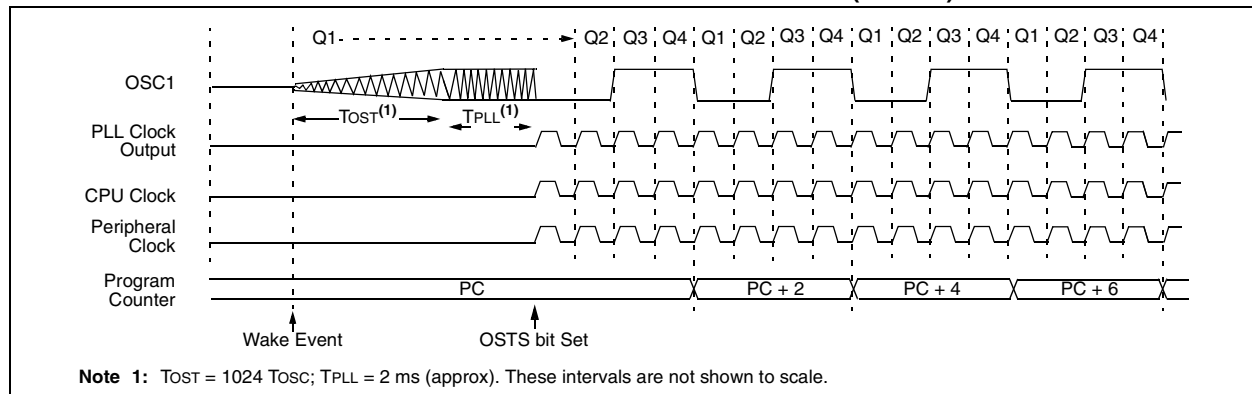

FIGURE 3-6: TRANSITION TIMING FOR WAKE FROM SLEEP (HSPLL)



PIC18F85J90 FAMILY

3.4.1 PRI_IDLE MODE

This mode is unique among the three low-power Idle modes, in that it does not disable the primary device clock. For timing sensitive applications, this allows for the fastest resumption of device operation with its more accurate primary clock source, since the clock source does not have to “warm up” or transition from another oscillator.

PRI_IDLE mode is entered from PRI_RUN mode by setting the IDLEN bit and executing a SLEEP instruction. If the device is in another Run mode, set IDLEN first, then set the SCS bits to ‘10’ and execute SLEEP. Although the CPU is disabled, the peripherals continue to be clocked from the primary clock source specified by the FOSC1:FOSC0 Configuration bits. The OSTS bit remains set (see Figure 3-7).

When a wake event occurs, the CPU is clocked from the primary clock source. A delay of interval T_{CSD} is required between the wake event and when code execution starts. This is required to allow the CPU to become ready to execute instructions. After the wake-up, the OSTS bit remains set. The IDLEN and SCS bits are not affected by the wake-up (see Figure 3-8).

3.4.2 SEC_IDLE MODE

In SEC_IDLE mode, the CPU is disabled but the peripherals continue to be clocked from the Timer1 oscillator. This mode is entered from SEC_RUN by setting the IDLEN bit and executing a SLEEP instruction. If the device is in another Run mode, set IDLEN first, then set SCS1:SCS0 to ‘01’ and execute SLEEP. When the clock source is switched to the Timer1 oscillator, the primary oscillator is shut down, the OSTS bit is cleared and the T1RUN bit is set.

When a wake event occurs, the peripherals continue to be clocked from the Timer1 oscillator. After an interval of T_{CSD} following the wake event, the CPU begins executing code being clocked by the Timer1 oscillator. The IDLEN and SCS bits are not affected by the wake-up; the Timer1 oscillator continues to run (see Figure 3-8).

Note: The Timer1 oscillator should already be running prior to entering SEC_IDLE mode. If the T1OSCEN bit is not set when the SLEEP instruction is executed, the SLEEP instruction will be ignored and entry to SEC_IDLE mode will not occur. If the Timer1 oscillator is enabled, but not yet running, peripheral clocks will be delayed until the oscillator has started. In such situations, initial oscillator operation is far from stable and unpredictable operation may result.

FIGURE 3-7: TRANSITION TIMING FOR ENTRY TO IDLE MODE

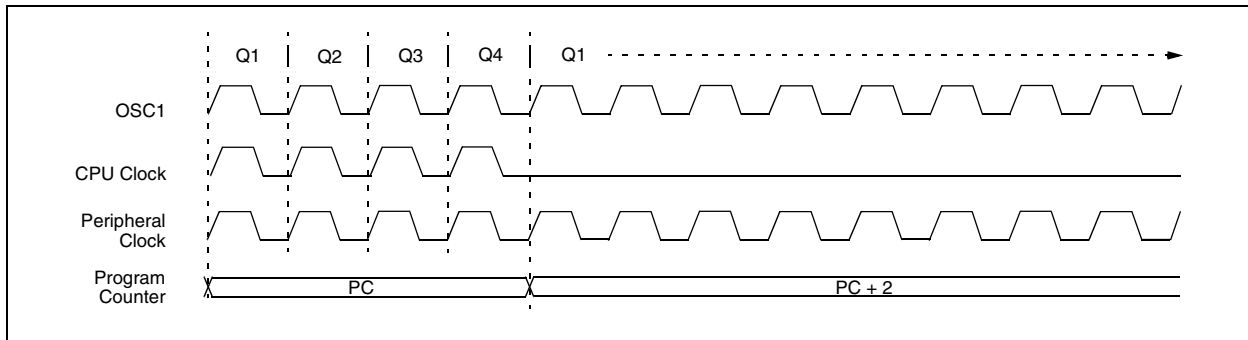
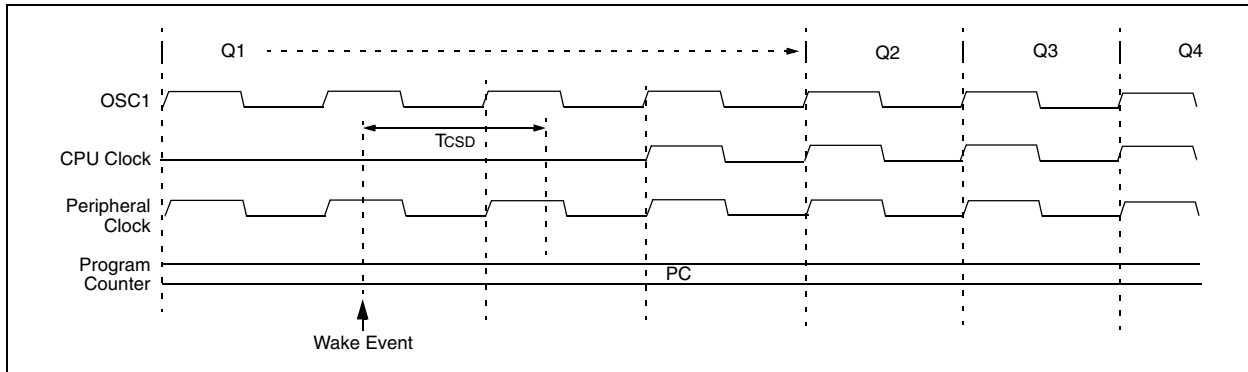

FIGURE 3-8: TRANSITION TIMING FOR WAKE FROM IDLE TO RUN MODE



3.4.3 RC_IDLE MODE

In RC_IDLE mode, the CPU is disabled but the peripherals continue to be clocked from the internal oscillator. This mode allows for controllable power conservation during Idle periods.

From RC_RUN, this mode is entered by setting the IDLEN bit and executing a SLEEP instruction. If the device is in another Run mode, first set IDLEN, then clear the SCS bits and execute SLEEP. When the clock source is switched to the INTRC, the primary oscillator is shut down and the OSTS bit is cleared.

When a wake event occurs, the peripherals continue to be clocked from the INTOSC. After a delay of T_{CSD} following the wake event, the CPU begins executing code being clocked by the INTOSC. The IDLEN and SCS bits are not affected by the wake-up. The INTOSC source will continue to run if either the WDT or the Fail-Safe Clock Monitor is enabled.

3.5 Exiting Idle and Sleep Modes

An exit from Sleep mode, or any of the Idle modes, is triggered by an interrupt, a Reset or a WDT time-out. This section discusses the triggers that cause exits from power-managed modes. The clocking subsystem actions are discussed in each of the power-managed mode sections (see **Section 3.2 “Run Modes”**, **Section 3.3 “Sleep Mode”** and **Section 3.4 “Idle Modes”**).

3.5.1 EXIT BY INTERRUPT

Any of the available interrupt sources can cause the device to exit from an Idle mode, or the Sleep mode, to a Run mode. To enable this functionality, an interrupt source must be enabled by setting its enable bit in one of the INTCON or PIE registers. The exit sequence is initiated when the corresponding interrupt flag bit is set.

On all exits from Idle or Sleep modes by interrupt, code execution branches to the interrupt vector if the GIE/GIEH bit (INTCON<7>) is set. Otherwise, code execution continues or resumes without branching (see **Section 8.0 “Interrupts”**).

A fixed delay of interval T_{CSD} following the wake event is required when leaving Sleep and Idle modes. This delay is required for the CPU to prepare for execution. Instruction execution resumes on the first clock cycle following this delay.

3.5.2 EXIT BY WDT TIME-OUT

A WDT time-out will cause different actions depending on which power-managed mode the device is in when the time-out occurs.

If the device is not executing code (all Idle modes and Sleep mode), the time-out will result in an exit from the power-managed mode (see **Section 3.2 “Run Modes”** and **Section 3.3 “Sleep Mode”**). If the device is executing code (all Run modes), the time-out will result in a WDT Reset (see **Section 22.2 “Watchdog Timer (WDT)”**).

The Watchdog Timer and postscaler are cleared by one of the following events:

- executing a SLEEP or CLRWDT instruction
- the loss of a currently selected clock source (if the Fail-Safe Clock Monitor is enabled)

3.5.3 EXIT BY RESET

Exiting an Idle or Sleep mode by Reset automatically forces the device to run from the INTRC.

3.5.4 EXIT WITHOUT AN OSCILLATOR START-UP DELAY

Certain exits from power-managed modes do not invoke the OST at all. There are two cases:

- PRI_IDLE mode, where the primary clock source is not stopped; and
- the primary clock source is either the EC or ECPLL mode.

In these instances, the primary clock source either does not require an oscillator start-up delay, since it is already running (PRI_IDLE), or normally does not require an oscillator start-up delay (EC). However, a fixed delay of interval T_{CSD} following the wake event is still required when leaving Sleep and Idle modes to allow the CPU to prepare for execution. Instruction execution resumes on the first clock cycle following this delay.

PIC18F85J90 FAMILY

NOTES:

PIC18F85J90 FAMILY

4.0 RESET

The PIC18F85J90 family of devices differentiate between various kinds of Reset:

- Power-on Reset (POR)
- $\overline{\text{MCLR}}$ Reset during normal operation
- $\overline{\text{MCLR}}$ Reset during power-managed modes
- Watchdog Timer (WDT) Reset (during execution)
- Brown-out Reset (BOR)
- RESET Instruction
- Stack Full Reset
- Stack Underflow Reset

This section discusses Resets generated by $\overline{\text{MCLR}}$, POR and BOR and covers the operation of the various start-up timers. Stack Reset events are covered in **Section 5.1.4.4 “Stack Full and Underflow Resets”**. WDT Resets are covered in **Section 22.2 “Watchdog Timer (WDT)”**.

A simplified block diagram of the on-chip Reset circuit is shown in Figure 4-1.

4.1 RCON Register

Device Reset events are tracked through the RCON register (Register 4-1). The lower five bits of the register indicate that a specific Reset event has occurred. In most cases, these bits can only be set by the event and must be cleared by the application after the event. The state of these flag bits, taken together, can be read to indicate the type of Reset that just occurred. This is described in more detail in **Section 4.6 “Reset State of Registers”**.

The RCON register also has a control bit for setting interrupt priority (IPEN). Interrupt priority is discussed in **Section 8.0 “Interrupts”**.

FIGURE 4-1: SIMPLIFIED BLOCK DIAGRAM OF ON-CHIP RESET CIRCUIT

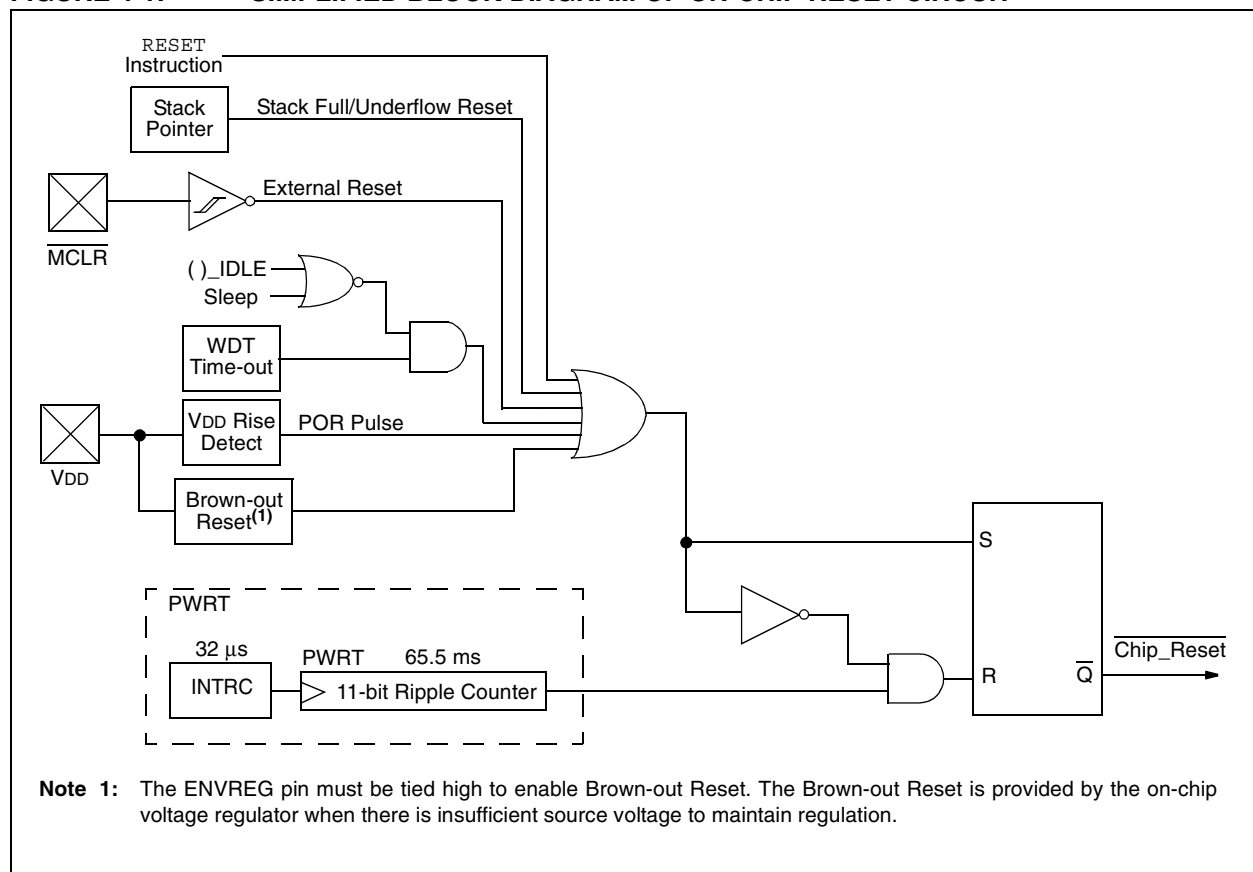

PIC18F85J90 FAMILY

REGISTER 4-1: RCON: RESET CONTROL REGISTER

R/W-0	U-0	U-0	R/W-1	R-1	R-1	R/W-0	R/W-0
IPEN	—	—	\overline{RI}	\overline{TO}	\overline{PD}	\overline{POR}	\overline{BOR}
bit 7							bit 0

Legend:

R = Readable bit W = Writable bit U = Unimplemented bit, read as '0'
 -n = Value at POR '1' = Bit is set '0' = Bit is cleared x = Bit is unknown

- bit 7 **IPEN:** Interrupt Priority Enable bit
 1 = Enable priority levels on interrupts
 0 = Disable priority levels on interrupts (PIC16XXXX Compatibility mode)
- bit 6-5 **Unimplemented:** Read as '0'
- bit 4 **\overline{RI} :** RESET Instruction Flag bit
 1 = The RESET instruction was not executed (set by firmware only)
 0 = The RESET instruction was executed causing a device Reset (must be set in software after a Brown-out Reset occurs)
- bit 3 **\overline{TO} :** Watchdog Time-out Flag bit
 1 = Set by power-up, CLRWDT instruction or SLEEP instruction
 0 = A WDT time-out occurred
- bit 2 **\overline{PD} :** Power-Down Detection Flag bit
 1 = Set by power-up or by the CLRWDT instruction
 0 = Set by execution of the SLEEP instruction
- bit 1 **\overline{POR} :** Power-on Reset Status bit
 1 = A Power-on Reset has not occurred (set by firmware only)
 0 = A Power-on Reset occurred (must be set in software after a Power-on Reset occurs)
- bit 0 **\overline{BOR} :** Brown-out Reset Status bit
 1 = A Brown-out Reset has not occurred (set by firmware only)
 0 = A Brown-out Reset occurred (must be set in software after a Brown-out Reset occurs)

Note 1: It is recommended that the \overline{POR} bit be set after a Power-on Reset has been detected, so that subsequent Power-on Resets may be detected.

2: If the on-chip voltage regulator is disabled, \overline{BOR} remains '0' at all times. See **Section 4.4.1 "Detecting BOR"** for more information.

3: Brown-out Reset is said to have occurred when \overline{BOR} is '0' and \overline{POR} is '1' (assuming that \overline{POR} was set to '1' by software immediately after a Power-on Reset).

4.2 Master Clear ($\overline{\text{MCLR}}$)

The $\overline{\text{MCLR}}$ pin provides a method for triggering a hard external Reset of the device. A Reset is generated by holding the pin low. PIC18 extended microcontroller devices have a noise filter in the $\overline{\text{MCLR}}$ Reset path which detects and ignores small pulses.

The $\overline{\text{MCLR}}$ pin is not driven low by any internal Resets, including the WDT.

4.3 Power-on Reset (POR)

A Power-on Reset condition is generated on-chip whenever V_{DD} rises above a certain threshold. This allows the device to start in the initialized state when V_{DD} is adequate for operation.

To take advantage of the POR circuitry, tie the $\overline{\text{MCLR}}$ pin through a resistor (1 k Ω to 10 k Ω) to V_{DD} . This will eliminate external RC components usually needed to create a Power-on Reset delay. A minimum rise rate for V_{DD} is specified (parameter D004). For a slow rise time, see Figure 4-2.

When the device starts normal operation (i.e., exits the Reset condition), device operating parameters (voltage, frequency, temperature, etc.) must be met to ensure operation. If these conditions are not met, the device must be held in Reset until the operating conditions are met.

Power-on Reset events are captured by the $\overline{\text{POR}}$ bit (RCON<1>). The state of the bit is set to '0' whenever a Power-on Reset occurs; it does not change for any other Reset event. $\overline{\text{POR}}$ is not reset to '1' by any hardware event. To capture multiple events, the user manually resets the bit to '1' in software following any Power-on Reset.

4.4 Brown-out Reset (BOR)

The PIC18F85J90 family of devices incorporates a simple BOR function when the internal regulator is enabled (ENVREG pin is tied to V_{DD}). The voltage regulator will trigger a Brown-out Reset when output of the regulator to the device core approaches the voltage at which the device is unable to run at full speed. The BOR circuit also keeps the device in Reset as V_{DD} rises, until the regulator's output level is sufficient for full-speed operation.

Once a BOR has occurred, the Power-up Timer will keep the chip in Reset for T_{PWRT} (parameter 33). If V_{DD} drops below the threshold for full-speed operation while the Power-up Timer is running, the chip will go back into a Brown-out Reset and the Power-up Timer will be initialized. Once V_{DD} rises to the point where regulator output is sufficient, the Power-up Timer will execute the additional time delay.

FIGURE 4-2: EXTERNAL POWER-ON RESET CIRCUIT (FOR SLOW V_{DD} POWER-UP)

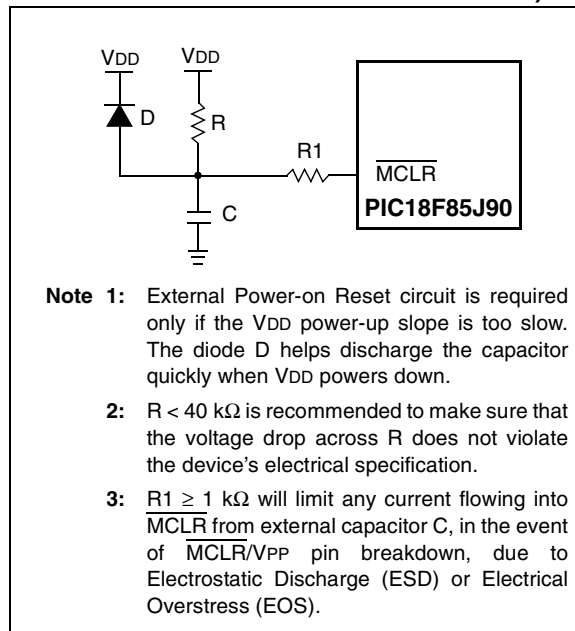

4.4.1 DETECTING BOR

The $\overline{\text{BOR}}$ bit always resets to '0' on any Brown-out Reset or Power-on Reset event. This makes it difficult to determine if a Brown-out Reset event has occurred just by reading the state of $\overline{\text{BOR}}$ alone. A more reliable method is to simultaneously check the state of both $\overline{\text{POR}}$ and $\overline{\text{BOR}}$. This assumes that the $\overline{\text{POR}}$ bit is reset to '1' in software immediately after any Power-on Reset event. If $\overline{\text{BOR}}$ is '0' while $\overline{\text{POR}}$ is '1', it can be reliably assumed that a Brown-out Reset event has occurred.

If the voltage regulator is disabled, Brown-out Reset functionality is disabled. In this case, the $\overline{\text{BOR}}$ bit cannot be used to determine a Brown-out Reset event. The $\overline{\text{BOR}}$ bit is still cleared by a Power-on Reset event.

PIC18F85J90 FAMILY

4.5 Power-up Timer (PWRT)

PIC18F85J90 family devices incorporate an on-chip Power-up Timer (PWRT) to help regulate the Power-on Reset process. The PWRT is always enabled. The main function is to ensure that the device voltage is stable before code is executed.

The Power-up Timer (PWRT) of the PIC18F85J90 family devices is an 11-bit counter which uses the INTRC source as the clock input. This yields an approximate time interval of $2048 \times 32 \mu\text{s} = 65.6 \text{ ms}$. While the PWRT is counting, the device is held in Reset.

The power-up time delay depends on the INTRC clock and will vary from chip-to-chip due to temperature and process variation. See DC parameter 33 for details.

4.5.1 TIME-OUT SEQUENCE

If enabled, the PWRT time-out is invoked after the POR pulse has cleared. The total time-out will vary based on the status of the PWRT. Figure 4-3, Figure 4-4, Figure 4-5 and Figure 4-6 all depict time-out sequences on power-up with the Power-up Timer enabled.

Since the time-outs occur from the POR pulse, if $\overline{\text{MCLR}}$ is kept low long enough, the PWRT will expire. Bringing $\overline{\text{MCLR}}$ high will begin execution immediately (Figure 4-5). This is useful for testing purposes, or to synchronize more than one PIC18FXXXX device operating in parallel.

FIGURE 4-3: TIME-OUT SEQUENCE ON POWER-UP ($\overline{\text{MCLR}}$ TIED TO V_{DD} , V_{DD} RISE < T_{PWRT})

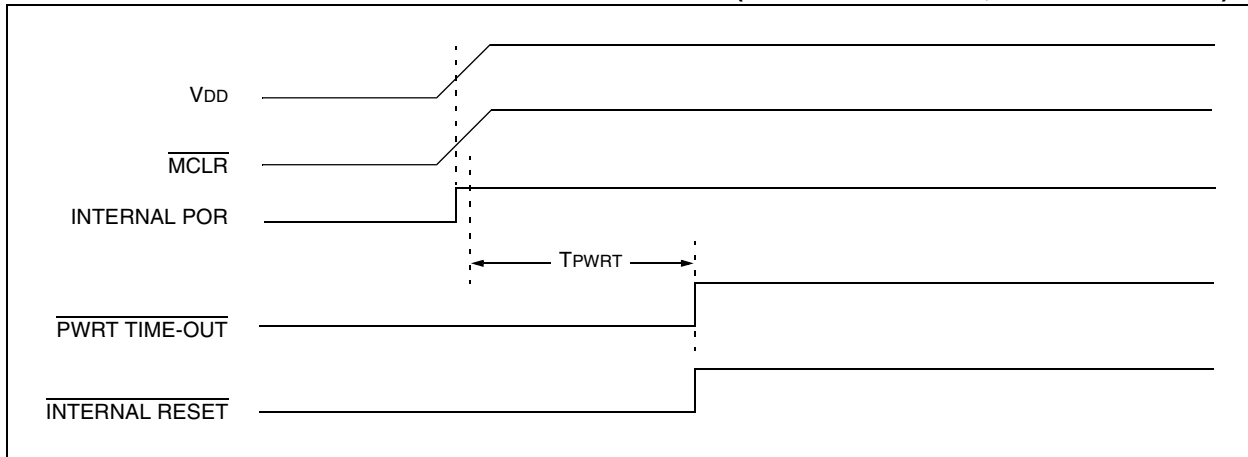
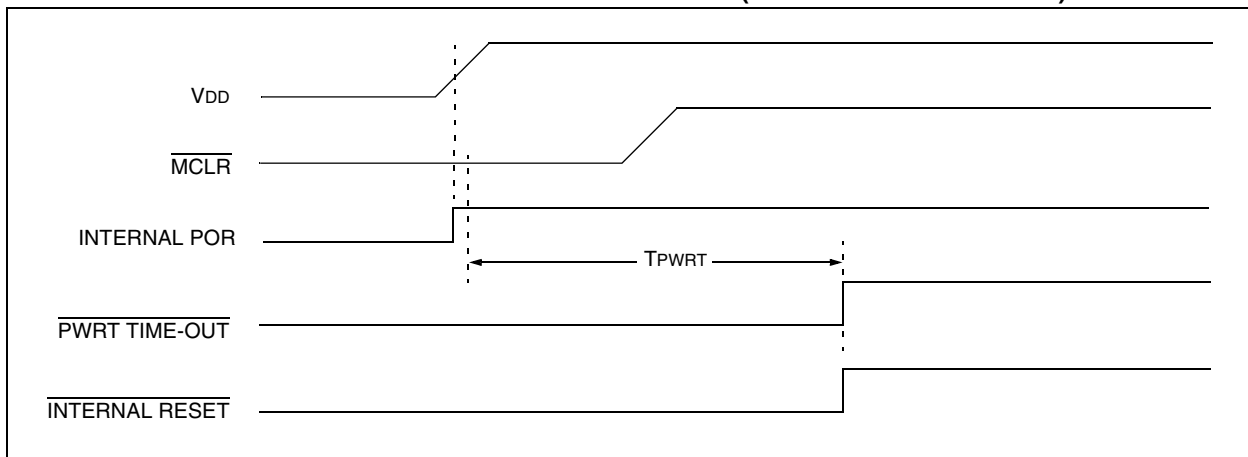

FIGURE 4-4: TIME-OUT SEQUENCE ON POWER-UP ($\overline{\text{MCLR}}$ NOT TIED TO V_{DD}): CASE 1



PIC18F85J90 FAMILY

FIGURE 4-5: TIME-OUT SEQUENCE ON POWER-UP ($\overline{\text{MCLR}}$ NOT TIED TO V_{DD}): CASE 2

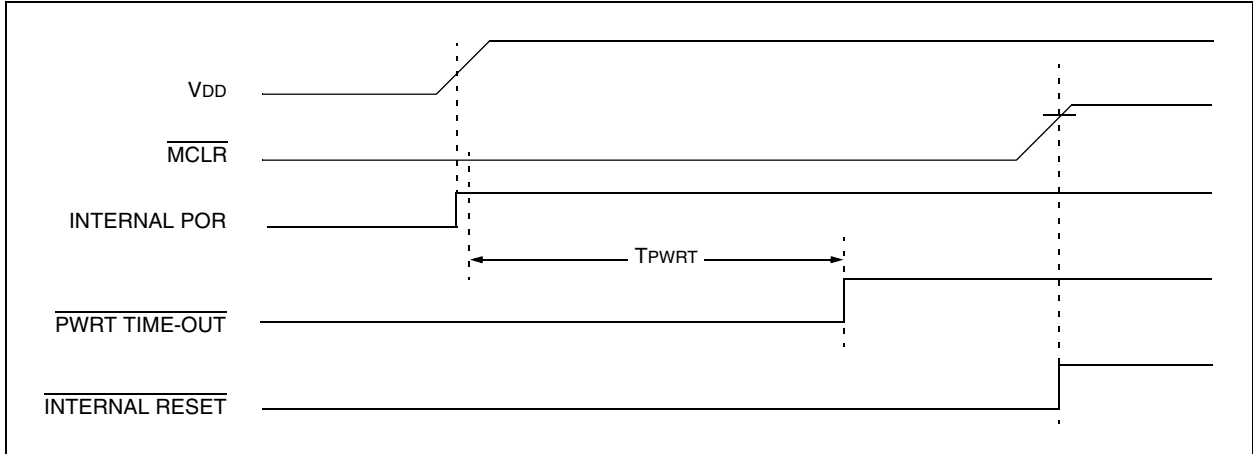
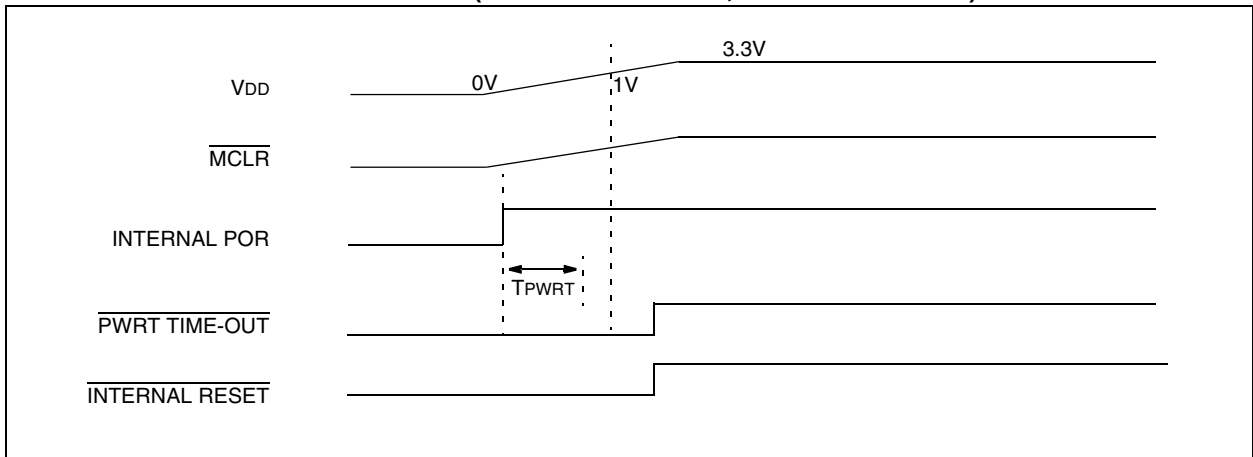

FIGURE 4-6: SLOW RISE TIME ($\overline{\text{MCLR}}$ TIED TO V_{DD} , V_{DD} RISE $>$ TPWRT)



PIC18F85J90 FAMILY

4.6 Reset State of Registers

Most registers are unaffected by a Reset. Their status is unknown on POR and unchanged by all other Resets. The other registers are forced to a “Reset state” depending on the type of Reset that occurred.

Most registers are not affected by a WDT wake-up, since this is viewed as the resumption of normal operation. Status bits from the RCON register, \overline{RI} , \overline{TO} , \overline{PD} , \overline{POR} and \overline{BOR} , are set or cleared differently in different Reset situations, as indicated in Table 4-1. These bits are used in software to determine the nature of the Reset.

Table 4-2 describes the Reset states for all of the Special Function Registers. These are categorized by Power-on and Brown-out Resets, Master Clear and WDT Resets and WDT wake-ups.

TABLE 4-1: STATUS BITS, THEIR SIGNIFICANCE AND THE INITIALIZATION CONDITION FOR RCON REGISTER

Condition	Program Counter ⁽¹⁾	RCON Register					STKPTR Register	
		\overline{RI}	\overline{TO}	\overline{PD}	\overline{POR}	\overline{BOR}	STKFUL	STKUNF
Power-on Reset	0000h	1	1	1	0	0	0	0
RESET Instruction	0000h	0	u	u	u	u	u	u
Brown-out Reset	0000h	1	1	1	u	0	u	u
\overline{MCLR} during power-managed Run modes	0000h	u	1	u	u	u	u	u
\overline{MCLR} during power-managed Idle modes and Sleep mode	0000h	u	1	0	u	u	u	u
WDT time-out during full power or power-managed Run modes	0000h	u	0	u	u	u	u	u
\overline{MCLR} during full power execution	0000h	u	u	u	u	u	u	u
Stack Full Reset (STVREN = 1)	0000h	u	u	u	u	u	1	u
Stack Underflow Reset (STVREN = 1)	0000h	u	u	u	u	u	u	1
Stack Underflow Error (not an actual Reset, STVREN = 0)	0000h	u	u	u	u	u	u	1
WDT time-out during power-managed Idle or Sleep modes	PC + 2	u	0	0	u	u	u	u
Interrupt exit from power-managed modes	PC + 2	u	u	0	u	u	u	u

Legend: u = unchanged

Note 1: When the wake-up is due to an interrupt and the GIEH or GIEL bit is set, the PC is loaded with the interrupt vector (0008h or 0018h).

PIC18F85J90 FAMILY

TABLE 4-2: INITIALIZATION CONDITIONS FOR ALL REGISTERS

Register	Applicable Devices		Power-on Reset, Brown-out Reset	MCLR Resets WDT Reset RESET Instruction Stack Resets	Wake-up via WDT or Interrupt
TOSU	PIC18F6XJ90	PIC18F8XJ90	---0 0000	---0 0000	---0 uuuu ⁽¹⁾
TOSH	PIC18F6XJ90	PIC18F8XJ90	0000 0000	0000 0000	uuuu uuuu ⁽¹⁾
TOSL	PIC18F6XJ90	PIC18F8XJ90	0000 0000	0000 0000	uuuu uuuu ⁽¹⁾
STKPTR	PIC18F6XJ90	PIC18F8XJ90	uu-0 0000	00-0 0000	uu-u uuuu ⁽¹⁾
PCLATU	PIC18F6XJ90	PIC18F8XJ90	---0 0000	---0 0000	---u uuuu
PCLATH	PIC18F6XJ90	PIC18F8XJ90	0000 0000	0000 0000	uuuu uuuu
PCL	PIC18F6XJ90	PIC18F8XJ90	0000 0000	0000 0000	PC + 2 ⁽²⁾
TBLPTRU	PIC18F6XJ90	PIC18F8XJ90	--00 0000	--00 0000	--uu uuuu
TBLPTRH	PIC18F6XJ90	PIC18F8XJ90	0000 0000	0000 0000	uuuu uuuu
TBLPTRL	PIC18F6XJ90	PIC18F8XJ90	0000 0000	0000 0000	uuuu uuuu
TABLAT	PIC18F6XJ90	PIC18F8XJ90	0000 0000	0000 0000	uuuu uuuu
PRODH	PIC18F6XJ90	PIC18F8XJ90	xxxx xxxx	uuuu uuuu	uuuu uuuu
PRODL	PIC18F6XJ90	PIC18F8XJ90	xxxx xxxx	uuuu uuuu	uuuu uuuu
INTCON	PIC18F6XJ90	PIC18F8XJ90	0000 000x	0000 000u	uuuu uuuu ⁽³⁾
INTCON2	PIC18F6XJ90	PIC18F8XJ90	1111 1111	1111 1111	uuuu uuuu ⁽³⁾
INTCON3	PIC18F6XJ90	PIC18F8XJ90	1100 0000	1100 0000	uuuu uuuu ⁽³⁾
INDF0	PIC18F6XJ90	PIC18F8XJ90	N/A	N/A	N/A
POSTINC0	PIC18F6XJ90	PIC18F8XJ90	N/A	N/A	N/A
POSTDEC0	PIC18F6XJ90	PIC18F8XJ90	N/A	N/A	N/A
PREINC0	PIC18F6XJ90	PIC18F8XJ90	N/A	N/A	N/A
PLUSW0	PIC18F6XJ90	PIC18F8XJ90	N/A	N/A	N/A
FSR0H	PIC18F6XJ90	PIC18F8XJ90	---- xxxx	---- uuuu	---- uuuu
FSR0L	PIC18F6XJ90	PIC18F8XJ90	xxxx xxxx	uuuu uuuu	uuuu uuuu
WREG	PIC18F6XJ90	PIC18F8XJ90	xxxx xxxx	uuuu uuuu	uuuu uuuu
INDF1	PIC18F6XJ90	PIC18F8XJ90	N/A	N/A	N/A
POSTINC1	PIC18F6XJ90	PIC18F8XJ90	N/A	N/A	N/A
POSTDEC1	PIC18F6XJ90	PIC18F8XJ90	N/A	N/A	N/A
PREINC1	PIC18F6XJ90	PIC18F8XJ90	N/A	N/A	N/A
PLUSW1	PIC18F6XJ90	PIC18F8XJ90	N/A	N/A	N/A

Legend: u = unchanged, x = unknown, - = unimplemented bit, read as '0', q = value depends on condition. Shaded cells indicate conditions do not apply for the designated device.

- Note 1:** When the wake-up is due to an interrupt and the GIEL or GIEH bit is set, the TOSU, TOSH and TOSL are updated with the current value of the PC. The STKPTR is modified to point to the next location in the hardware stack.
- 2:** When the wake-up is due to an interrupt and the GIEL or GIEH bit is set, the PC is loaded with the interrupt vector (0008h or 0018h).
- 3:** One or more bits in the INTCONx or PIRx registers will be affected (to cause wake-up).
- 4:** See Table 4-1 for Reset value for specific condition.
- 5:** Bits 6 and 7 of PORTA, LATA and TRISA are enabled depending on the oscillator mode selected. When not enabled as PORTA pins, they are disabled and read as '0'.

PIC18F85J90 FAMILY

TABLE 4-2: INITIALIZATION CONDITIONS FOR ALL REGISTERS (CONTINUED)

Register	Applicable Devices		Power-on Reset, Brown-out Reset	MCLR Resets WDT Reset RESET Instruction Stack Resets	Wake-up via WDT or Interrupt
FSR1H	PIC18F6XJ90	PIC18F8XJ90	---- xxxx	---- uuuu	---- uuuu
FSR1L	PIC18F6XJ90	PIC18F8XJ90	xxxx xxxx	uuuu uuuu	uuuu uuuu
BSR	PIC18F6XJ90	PIC18F8XJ90	---- 0000	---- 0000	---- uuuu
INDF2	PIC18F6XJ90	PIC18F8XJ90	N/A	N/A	N/A
POSTINC2	PIC18F6XJ90	PIC18F8XJ90	N/A	N/A	N/A
POSTDEC2	PIC18F6XJ90	PIC18F8XJ90	N/A	N/A	N/A
PREINC2	PIC18F6XJ90	PIC18F8XJ90	N/A	N/A	N/A
PLUSW2	PIC18F6XJ90	PIC18F8XJ90	N/A	N/A	N/A
FSR2H	PIC18F6XJ90	PIC18F8XJ90	---- xxxx	---- uuuu	---- uuuu
FSR2L	PIC18F6XJ90	PIC18F8XJ90	xxxx xxxx	uuuu uuuu	uuuu uuuu
STATUS	PIC18F6XJ90	PIC18F8XJ90	---x xxxx	---u uuuu	---u uuuu
TMR0H	PIC18F6XJ90	PIC18F8XJ90	0000 0000	0000 0000	uuuu uuuu
TMR0L	PIC18F6XJ90	PIC18F8XJ90	xxxx xxxx	uuuu uuuu	uuuu uuuu
T0CON	PIC18F6XJ90	PIC18F8XJ90	1111 1111	1111 1111	uuuu uuuu
OSCCON	PIC18F6XJ90	PIC18F8XJ90	0100 q000	0100 q000	uuuu quuu
LCDREG	PIC18F6XJ90	PIC18F8XJ90	-011 1100	-011 1000	-uuu uuuu
WDTCON	PIC18F6XJ90	PIC18F8XJ90	0--- ---0	0--- ---0	u--- ---u
RCON ⁽⁴⁾	PIC18F6XJ90	PIC18F8XJ90	0--1 11q0	0--q qquu	u--u qquu
TMR1H	PIC18F6XJ90	PIC18F8XJ90	xxxx xxxx	uuuu uuuu	uuuu uuuu
TMR1L	PIC18F6XJ90	PIC18F8XJ90	xxxx xxxx	uuuu uuuu	uuuu uuuu
T1CON	PIC18F6XJ90	PIC18F8XJ90	0000 0000	u0uu uuuu	uuuu uuuu
TMR2	PIC18F6XJ90	PIC18F8XJ90	0000 0000	0000 0000	uuuu uuuu
PR2	PIC18F6XJ90	PIC18F8XJ90	1111 1111	1111 1111	1111 1111
T2CON	PIC18F6XJ90	PIC18F8XJ90	-000 0000	-000 0000	-uuu uuuu
SSPBUF	PIC18F6XJ90	PIC18F8XJ90	xxxx xxxx	uuuu uuuu	uuuu uuuu
SSPADD	PIC18F6XJ90	PIC18F8XJ90	0000 0000	0000 0000	uuuu uuuu
SSPSTAT	PIC18F6XJ90	PIC18F8XJ90	0000 0000	0000 0000	uuuu uuuu
SSPCON1	PIC18F6XJ90	PIC18F8XJ90	0000 0000	0000 0000	uuuu uuuu
SSPCON2	PIC18F6XJ90	PIC18F8XJ90	0000 0000	0000 0000	uuuu uuuu

Legend: u = unchanged, x = unknown, - = unimplemented bit, read as '0', q = value depends on condition.
Shaded cells indicate conditions do not apply for the designated device.

- Note 1:** When the wake-up is due to an interrupt and the GIEL or GIEH bit is set, the TOSU, TOSH and TOSL are updated with the current value of the PC. The STKPTR is modified to point to the next location in the hardware stack.
- 2:** When the wake-up is due to an interrupt and the GIEL or GIEH bit is set, the PC is loaded with the interrupt vector (0008h or 0018h).
- 3:** One or more bits in the INTCONx or PIRx registers will be affected (to cause wake-up).
- 4:** See Table 4-1 for Reset value for specific condition.
- 5:** Bits 6 and 7 of PORTA, LATA and TRISA are enabled depending on the oscillator mode selected. When not enabled as PORTA pins, they are disabled and read as '0'.

PIC18F85J90 FAMILY

TABLE 4-2: INITIALIZATION CONDITIONS FOR ALL REGISTERS (CONTINUED)

Register	Applicable Devices		Power-on Reset, Brown-out Reset	MCLR Resets WDT Reset RESET Instruction Stack Resets	Wake-up via WDT or Interrupt
ADRESH	PIC18F6XJ90	PIC18F8XJ90	xxxx xxxx	uuuu uuuu	uuuu uuuu
ADRESL	PIC18F6XJ90	PIC18F8XJ90	xxxx xxxx	uuuu uuuu	uuuu uuuu
ADCON0	PIC18F6XJ90	PIC18F8XJ90	0-00 0000	0-00 0000	u-uu uuuu
ADCON1	PIC18F6XJ90	PIC18F8XJ90	--00 0000	--00 0000	--uu uuuu
ADCON2	PIC18F6XJ90	PIC18F8XJ90	0-00 0000	0-00 0000	u-uu uuuu
LCDDATA4	PIC18F6XJ90	PIC18F8XJ90	---- -x	---- -u	---- -u
LCDDATA4	PIC18F6XJ90	PIC18F8XJ90	xxxx xxxx	uuuu uuuu	uuuu uuuu
LCDDATA3	PIC18F6XJ90	PIC18F8XJ90	xxxx xxxx	uuuu uuuu	uuuu uuuu
LCDDATA2	PIC18F6XJ90	PIC18F8XJ90	xxxx xxxx	uuuu uuuu	uuuu uuuu
LCDDATA1	PIC18F6XJ90	PIC18F8XJ90	xxxx xxxx	uuuu uuuu	uuuu uuuu
LCDDATA0	PIC18F6XJ90	PIC18F8XJ90	xxxx xxxx	uuuu uuuu	uuuu uuuu
LCDSE5	PIC18F6XJ90	PIC18F8XJ90	0000 0000	uuuu uuuu	uuuu uuuu
LCDSE4	PIC18F6XJ90	PIC18F8XJ90	---- -0	---- -u	---- -u
LCDSE4	PIC18F6XJ90	PIC18F8XJ90	0000 0000	uuuu uuuu	uuuu uuuu
LCDSE3	PIC18F6XJ90	PIC18F8XJ90	0000 0000	uuuu uuuu	uuuu uuuu
LCDSE2	PIC18F6XJ90	PIC18F8XJ90	0000 0000	uuuu uuuu	uuuu uuuu
LCDSE1	PIC18F6XJ90	PIC18F8XJ90	0000 0000	uuuu uuuu	uuuu uuuu
CVRCON	PIC18F6XJ90	PIC18F8XJ90	0000 0000	0000 0000	uuuu uuuu
CMCON	PIC18F6XJ90	PIC18F8XJ90	0000 0111	0000 0111	uuuu uuuu
TMR3H	PIC18F6XJ90	PIC18F8XJ90	xxxx xxxx	uuuu uuuu	uuuu uuuu
TMR3L	PIC18F6XJ90	PIC18F8XJ90	xxxx xxxx	uuuu uuuu	uuuu uuuu
T3CON	PIC18F6XJ90	PIC18F8XJ90	0000 0000	uuuu uuuu	uuuu uuuu
SPBRG1	PIC18F6XJ90	PIC18F8XJ90	0000 0000	0000 0000	uuuu uuuu
RCREG1	PIC18F6XJ90	PIC18F8XJ90	0000 0000	0000 0000	uuuu uuuu
TXREG1	PIC18F6XJ90	PIC18F8XJ90	0000 0000	0000 0000	uuuu uuuu
TXSTA1	PIC18F6XJ90	PIC18F8XJ90	0000 0010	0000 0010	uuuu uuuu
RCSTA1	PIC18F6XJ90	PIC18F8XJ90	0000 000x	0000 000x	uuuu uuuu
LCDPS	PIC18F6XJ90	PIC18F8XJ90	0000 0000	0000 0000	uuuu uuuu
LCDSE0	PIC18F6XJ90	PIC18F8XJ90	0000 0000	uuuu uuuu	uuuu uuuu
LCDCON	PIC18F6XJ90	PIC18F8XJ90	000- 0000	000- 0000	uuu- uuuu
EECON2	PIC18F6XJ90	PIC18F8XJ90	---- -	---- -	---- -
EECON1	PIC18F6XJ90	PIC18F8XJ90	---0 x00-	---0 u00-	---0 u00-

Legend: u = unchanged, x = unknown, - = unimplemented bit, read as '0', q = value depends on condition. Shaded cells indicate conditions do not apply for the designated device.

Note 1: When the wake-up is due to an interrupt and the GIEL or GIEH bit is set, the TOSU, TOSH and TOSL are updated with the current value of the PC. The STKPTR is modified to point to the next location in the hardware stack.

2: When the wake-up is due to an interrupt and the GIEL or GIEH bit is set, the PC is loaded with the interrupt vector (0008h or 0018h).

3: One or more bits in the INTCONx or PIRx registers will be affected (to cause wake-up).

4: See Table 4-1 for Reset value for specific condition.

5: Bits 6 and 7 of PORTA, LATA and TRISA are enabled depending on the oscillator mode selected. When not enabled as PORTA pins, they are disabled and read as '0'.

PIC18F85J90 FAMILY

TABLE 4-2: INITIALIZATION CONDITIONS FOR ALL REGISTERS (CONTINUED)

Register	Applicable Devices		Power-on Reset, Brown-out Reset	MCLR Resets WDT Reset RESET Instruction Stack Resets	Wake-up via WDT or Interrupt
IPR3	PIC18F6XJ90	PIC18F8XJ90	-111 -11-	-111 -11-	-uuu -uu-
PIR3	PIC18F6XJ90	PIC18F8XJ90	-000 -00-	-000 -00-	-uuu -00-(3)
PIE3	PIC18F6XJ90	PIC18F8XJ90	-000 -00-	-000 -00-	-uuu -00-
IPR2	PIC18F6XJ90	PIC18F8XJ90	11-- 111-	11-- 111-	uu-- uuu-
PIR2	PIC18F6XJ90	PIC18F8XJ90	00-- 000-	00-- 000-	uu-- uuu-(3)
PIE2	PIC18F6XJ90	PIC18F8XJ90	00-- 000-	00-- 000-	uu-- uuu-
IPR1	PIC18F6XJ90	PIC18F8XJ90	-111 1-11	-111 1-11	-uuu u-uu
PIR1	PIC18F6XJ90	PIC18F8XJ90	-000 0-00	-000 0-00	-uuu u-uu(3)
PIE1	PIC18F6XJ90	PIC18F8XJ90	-000 0-00	-000 0-00	-uuu u-uu
OSCTUNE	PIC18F6XJ90	PIC18F8XJ90	0000 0000	0000 0000	uuuu uuuu
TRISJ	PIC18F6XJ90	PIC18F8XJ90	1111 1111	1111 1111	uuuu uuuu
TRISH	PIC18F6XJ90	PIC18F8XJ90	1111 1111	1111 1111	uuuu uuuu
TRISG	PIC18F6XJ90	PIC18F8XJ90	0001 1111	0001 1111	uuuu uuuu
TRISF	PIC18F6XJ90	PIC18F8XJ90	1111 111-	1111 111-	uuuu uuu-
TRISE	PIC18F6XJ90	PIC18F8XJ90	1111 1-11	1111 1-11	uuuu u-uu
TRISD	PIC18F6XJ90	PIC18F8XJ90	1111 1111	1111 1111	uuuu uuuu
TRISC	PIC18F6XJ90	PIC18F8XJ90	1111 1111	1111 1111	uuuu uuuu
TRISB	PIC18F6XJ90	PIC18F8XJ90	1111 1111	1111 1111	uuuu uuuu
TRISA(5)	PIC18F6XJ90	PIC18F8XJ90	1111 1111(5)	1111 1111(5)	uuuu uuuu(5)
LATJ	PIC18F6XJ90	PIC18F8XJ90	xxxx xxxx	uuuu uuuu	uuuu uuuu
LATH	PIC18F6XJ90	PIC18F8XJ90	xxxx xxxx	uuuu uuuu	uuuu uuuu
LATG	PIC18F6XJ90	PIC18F8XJ90	00-x xxxx	00-u uuuu	uu-u uuuu
LATF	PIC18F6XJ90	PIC18F8XJ90	xxxx xxx-	uuuu uuu-	uuuu uuu-
LATE	PIC18F6XJ90	PIC18F8XJ90	xxxx xxxx	uuuu uuuu	uuuu uuuu
LATD	PIC18F6XJ90	PIC18F8XJ90	xxxx xxxx	uuuu uuuu	uuuu uuuu
LATC	PIC18F6XJ90	PIC18F8XJ90	xxxx xxxx	uuuu uuuu	uuuu uuuu
LATB	PIC18F6XJ90	PIC18F8XJ90	xxxx xxxx	uuuu uuuu	uuuu uuuu
LATA(5)	PIC18F6XJ90	PIC18F8XJ90	xxxx xxxx(5)	uuuu uuuu(5)	uuuu uuuu(5)
PORTJ	PIC18F6XJ90	PIC18F8XJ90	xxxx xxxx	uuuu uuuu	uuuu uuuu
PORTH	PIC18F6XJ90	PIC18F8XJ90	xxxx xxxx	uuuu uuuu	uuuu uuuu
PORTG	PIC18F6XJ90	PIC18F8XJ90	000x xxxx	000u uuuu	000u uuuu
PORTF	PIC18F6XJ90	PIC18F8XJ90	xxxx xxx-	uuuu uuu-	uuuu uuu-

Legend: u = unchanged, x = unknown, - = unimplemented bit, read as '0', q = value depends on condition. Shaded cells indicate conditions do not apply for the designated device.

Note 1: When the wake-up is due to an interrupt and the GIEL or GIEH bit is set, the TOSU, TOSH and TOSL are updated with the current value of the PC. The STKPTR is modified to point to the next location in the hardware stack.

2: When the wake-up is due to an interrupt and the GIEL or GIEH bit is set, the PC is loaded with the interrupt vector (0008h or 0018h).

3: One or more bits in the INTCONx or PIRx registers will be affected (to cause wake-up).

4: See Table 4-1 for Reset value for specific condition.

5: Bits 6 and 7 of PORTA, LATA and TRISA are enabled depending on the oscillator mode selected. When not enabled as PORTA pins, they are disabled and read as '0'.

PIC18F85J90 FAMILY

TABLE 4-2: INITIALIZATION CONDITIONS FOR ALL REGISTERS (CONTINUED)

Register	Applicable Devices		Power-on Reset, Brown-out Reset	MCLR Resets WDT Reset RESET Instruction Stack Resets	Wake-up via WDT or Interrupt
PORTE	PIC18F6XJ90	PIC18F8XJ90	xxxx x-xx	uuuu u-uu	uuuu u-uu
PORTD	PIC18F6XJ90	PIC18F8XJ90	xxxx xxxx	uuuu uuuu	uuuu uuuu
PORTC	PIC18F6XJ90	PIC18F8XJ90	xxxx xxxx	uuuu uuuu	uuuu uuuu
PORTB	PIC18F6XJ90	PIC18F8XJ90	xxxx xxxx	uuuu uuuu	uuuu uuuu
PORTA ⁽⁵⁾	PIC18F6XJ90	PIC18F8XJ90	xx0x 0000 ⁽⁵⁾	uu0u 0000 ⁽⁵⁾	uuuu uuuu ⁽⁵⁾
SPBRGH1	PIC18F6XJ90	PIC18F8XJ90	0000 0000	0000 0000	uuuu uuuu
BAUDCON1	PIC18F6XJ90	PIC18F8XJ90	01-0 0-00	01-0 0-00	uu-u u-uu
LCDDATA23	PIC18F6XJ90	PIC18F8XJ90	xxxx xxxx	uuuu uuuu	uuuu uuuu
LCDDATA22	PIC18F6XJ90	PIC18F8XJ90	---- --x	---- --u	---- --u
LCDDATA22	PIC18F6XJ90	PIC18F8XJ90	xxxx xxxx	uuuu uuuu	uuuu uuuu
LCDDATA21	PIC18F6XJ90	PIC18F8XJ90	xxxx xxxx	uuuu uuuu	uuuu uuuu
LCDDATA20	PIC18F6XJ90	PIC18F8XJ90	xxxx xxxx	uuuu uuuu	uuuu uuuu
LCDDATA19	PIC18F6XJ90	PIC18F8XJ90	xxxx xxxx	uuuu uuuu	uuuu uuuu
LCDDATA18	PIC18F6XJ90	PIC18F8XJ90	xxxx xxxx	uuuu uuuu	uuuu uuuu
LCDDATA17	PIC18F6XJ90	PIC18F8XJ90	xxxx xxxx	uuuu uuuu	uuuu uuuu
LCDDATA16	PIC18F6XJ90	PIC18F8XJ90	---- --x	---- --u	---- --u
LCDDATA16	PIC18F6XJ90	PIC18F8XJ90	xxxx xxxx	uuuu uuuu	uuuu uuuu
LCDDATA15	PIC18F6XJ90	PIC18F8XJ90	xxxx xxxx	uuuu uuuu	uuuu uuuu
LCDDATA14	PIC18F6XJ90	PIC18F8XJ90	xxxx xxxx	uuuu uuuu	uuuu uuuu
LCDDATA13	PIC18F6XJ90	PIC18F8XJ90	xxxx xxxx	uuuu uuuu	uuuu uuuu
LCDDATA12	PIC18F6XJ90	PIC18F8XJ90	xxxx xxxx	uuuu uuuu	uuuu uuuu
LCDDATA11	PIC18F6XJ90	PIC18F8XJ90	xxxx xxxx	uuuu uuuu	uuuu uuuu
LCDDATA10	PIC18F6XJ90	PIC18F8XJ90	---- --x	---- --u	---- --u
LCDDATA10	PIC18F6XJ90	PIC18F8XJ90	xxxx xxxx	uuuu uuuu	uuuu uuuu
LCDDATA9	PIC18F6XJ90	PIC18F8XJ90	xxxx xxxx	uuuu uuuu	uuuu uuuu
LCDDATA8	PIC18F6XJ90	PIC18F8XJ90	xxxx xxxx	uuuu uuuu	uuuu uuuu
LCDDATA7	PIC18F6XJ90	PIC18F8XJ90	xxxx xxxx	uuuu uuuu	uuuu uuuu
LCDDATA6	PIC18F6XJ90	PIC18F8XJ90	xxxx xxxx	uuuu uuuu	uuuu uuuu
LCDDATA5	PIC18F6XJ90	PIC18F8XJ90	xxxx xxxx	uuuu uuuu	uuuu uuuu
CCPR1H	PIC18F6XJ90	PIC18F8XJ90	xxxx xxxx	uuuu uuuu	uuuu uuuu
CCPR1L	PIC18F6XJ90	PIC18F8XJ90	xxxx xxxx	uuuu uuuu	uuuu uuuu
CCP1CON	PIC18F6XJ90	PIC18F8XJ90	--00 0000	--00 0000	--uu uuuu
CCPR2H	PIC18F6XJ90	PIC18F8XJ90	xxxx xxxx	uuuu uuuu	uuuu uuuu

Legend: u = unchanged, x = unknown, - = unimplemented bit, read as '0', q = value depends on condition. Shaded cells indicate conditions do not apply for the designated device.

- Note 1:** When the wake-up is due to an interrupt and the GIEL or GIEH bit is set, the TOSU, TOSH and TOSL are updated with the current value of the PC. The STKPTR is modified to point to the next location in the hardware stack.
- 2:** When the wake-up is due to an interrupt and the GIEL or GIEH bit is set, the PC is loaded with the interrupt vector (0008h or 0018h).
- 3:** One or more bits in the INTCONx or PIRx registers will be affected (to cause wake-up).
- 4:** See Table 4-1 for Reset value for specific condition.
- 5:** Bits 6 and 7 of PORTA, LATA and TRISA are enabled depending on the oscillator mode selected. When not enabled as PORTA pins, they are disabled and read as '0'.

PIC18F85J90 FAMILY

TABLE 4-2: INITIALIZATION CONDITIONS FOR ALL REGISTERS (CONTINUED)

Register	Applicable Devices		Power-on Reset, Brown-out Reset	MCLR Resets WDT Reset RESET Instruction Stack Resets	Wake-up via WDT or Interrupt
CCPR2L	PIC18F6XJ90	PIC18F8XJ90	xxxx xxxx	uuuu uuuu	uuuu uuuu
CCP2CON	PIC18F6XJ90	PIC18F8XJ90	--00 0000	--00 0000	--uu uuuu
SPBRG2	PIC18F6XJ90	PIC18F8XJ90	0000 0000	0000 0000	uuuu uuuu
RCREG2	PIC18F6XJ90	PIC18F8XJ90	0000 0000	0000 0000	uuuu uuuu
TXREG2	PIC18F6XJ90	PIC18F8XJ90	0000 0000	0000 0000	uuuu uuuu
TXSTA2	PIC18F6XJ90	PIC18F8XJ90	0000 -010	0000 -010	uuuu -uuu
RCSTA2	PIC18F6XJ90	PIC18F8XJ90	0000 000x	0000 000x	uuuu uuuu

Legend: u = unchanged, x = unknown, - = unimplemented bit, read as '0', q = value depends on condition.
Shaded cells indicate conditions do not apply for the designated device.

- Note 1:** When the wake-up is due to an interrupt and the GIEL or GIEH bit is set, the TOSU, TOSH and TOSL are updated with the current value of the PC. The STKPTR is modified to point to the next location in the hardware stack.
- 2:** When the wake-up is due to an interrupt and the GIEL or GIEH bit is set, the PC is loaded with the interrupt vector (0008h or 0018h).
- 3:** One or more bits in the INTCONx or PIRx registers will be affected (to cause wake-up).
- 4:** See Table 4-1 for Reset value for specific condition.
- 5:** Bits 6 and 7 of PORTA, LATA and TRISA are enabled depending on the oscillator mode selected. When not enabled as PORTA pins, they are disabled and read as '0'.

PIC18F85J90 FAMILY

5.0 MEMORY ORGANIZATION

There are two types of memory in PIC18 Flash microcontroller devices:

- Program Memory
- Data RAM

As Harvard architecture devices, the data and program memories use separate busses; this allows for concurrent access of the two memory spaces.

Additional detailed information on the operation of the Flash program memory is provided in **Section 6.0 “Flash Program Memory”**.

5.1 Program Memory Organization

PIC18 microcontrollers implement a 21-bit program counter which is capable of addressing a 2-Mbyte program memory space. Accessing a location between the upper boundary of the physically implemented memory and the 2-Mbyte address will return all ‘0’s (a NOP instruction).

The entire PIC18F85J90 family offers a range of on-chip Flash program memory sizes, from 8 Kbytes (up to 4,096 single-word instructions) to 32 Kbytes (32,768 single-word instructions). The program memory maps for individual family members are shown in Figure 5-1.

FIGURE 5-1: MEMORY MAPS FOR PIC18F85J90 FAMILY DEVICES

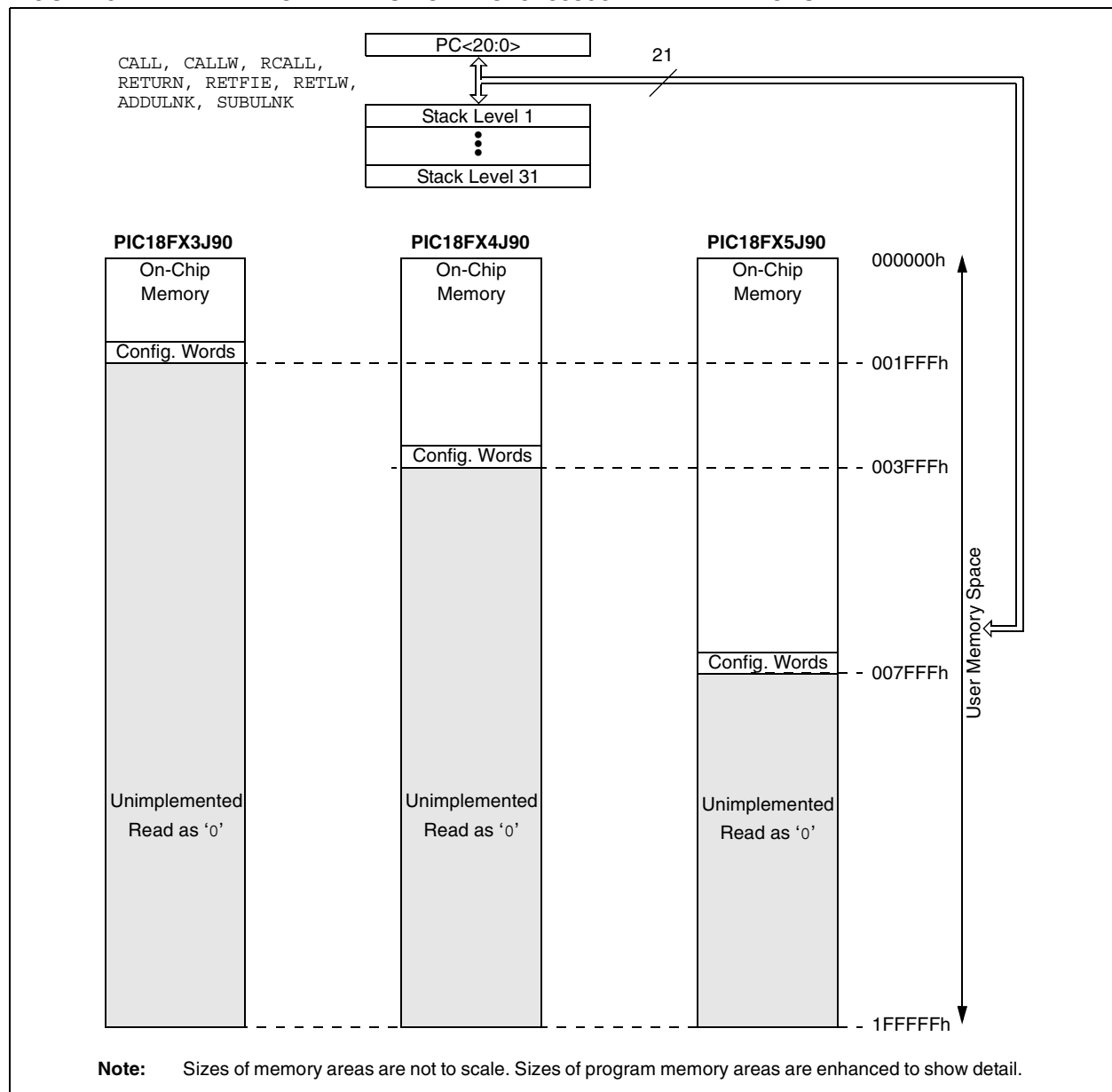

PIC18F85J90 FAMILY

5.1.1 HARD MEMORY VECTORS

All PIC18 devices have a total of three hard-coded return vectors in their program memory space. The Reset vector address is the default value to which the program counter returns on all device Resets; it is located at 0000h.

PIC18 devices also have two interrupt vector addresses for the handling of high priority and low priority interrupts. The high priority interrupt vector is located at 0008h and the low priority interrupt vector is at 0018h. Their locations in relation to the program memory map are shown in Figure 5-2.

FIGURE 5-2: HARD VECTOR AND CONFIGURATION WORD LOCATIONS FOR PIC18F85J90 FAMILY DEVICES

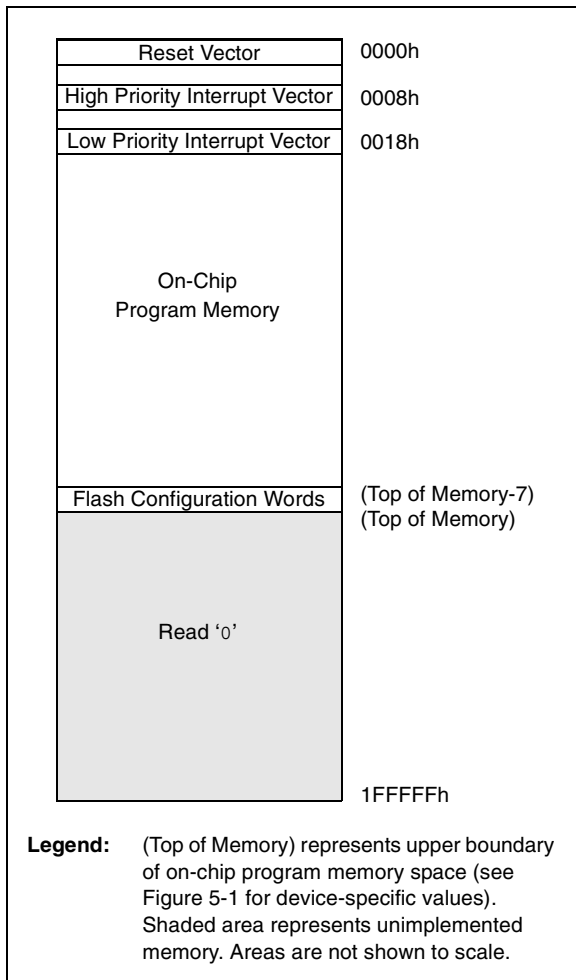

Legend: (Top of Memory) represents upper boundary of on-chip program memory space (see Figure 5-1 for device-specific values). Shaded area represents unimplemented memory. Areas are not shown to scale.

5.1.2 FLASH CONFIGURATION WORDS

Because PIC18F85J90 family devices do not have persistent configuration memory, the top four words of on-chip program memory are reserved for configuration information. On Reset, the configuration information is copied into the Configuration registers.

The Configuration Words are stored in their program memory location in numerical order, starting with the lower byte of CONFIG1 at the lowest address and ending with the upper byte of CONFIG4. For these devices, only Configuration Words, CONFIG1 through CONFIG3, are used; CONFIG4 is reserved. The actual addresses of the Flash Configuration Word for devices in the PIC18F85J90 family are shown in Table 5-1. Their location in the memory map is shown with the other memory vectors in Figure 5-2.

Additional details on the device Configuration Words are provided in **Section 22.1 "Configuration Bits"**.

TABLE 5-1: FLASH CONFIGURATION WORD FOR PIC18F85J90 FAMILY DEVICES

Device	Program Memory (Kbytes)	Configuration Word Addresses
PIC18F63J90	8	1FF8h to 1FFFh
PIC18F83J90		
PIC18F64J90	16	3FF8h to 3FFFh
PIC18F84J90		
PIC18F65J90	32	7FF8h to 7FFFh
PIC18F85J90		

5.1.3 PROGRAM COUNTER

The Program Counter (PC) specifies the address of the instruction to fetch for execution. The PC is 21 bits wide and is contained in three separate 8-bit registers. The low byte, known as the PCL register, is both readable and writable. The high byte, or PCH register, contains the PC<15:8> bits; it is not directly readable or writable. Updates to the PCH register are performed through the PCLATH register. The upper byte is called PCU. This register contains the PC<20:16> bits; it is also not directly readable or writable. Updates to the PCU register are performed through the PCLATU register.

The contents of PCLATH and PCLATU are transferred to the program counter by any operation that writes PCL. Similarly, the upper two bytes of the program counter are transferred to PCLATH and PCLATU by an operation that reads PCL. This is useful for computed offsets to the PC (see **Section 5.1.6.1 “Computed GOTO”**).

The PC addresses bytes in the program memory. To prevent the PC from becoming misaligned with word instructions, the Least Significant bit of PCL is fixed to a value of ‘0’. The PC increments by 2 to address sequential instructions in the program memory.

The CALL, RCALL, GOTO and program branch instructions write to the program counter directly. For these instructions, the contents of PCLATH and PCLATU are not transferred to the program counter.

5.1.4 RETURN ADDRESS STACK

The return address stack allows any combination of up to 31 program calls and interrupts to occur. The PC is pushed onto the stack when a CALL or RCALL instruction is executed, or an interrupt is Acknowledged. The PC value is pulled off the stack on a RETURN, RETLW or a RETFIE instruction (and on ADDULNK and SUBULNK instructions if the extended instruction set is enabled). PCLATU and PCLATH are not affected by any of the RETURN or CALL instructions.

The stack operates as a 31-word by 21-bit RAM and a 5-bit Stack Pointer, STKPTR. The stack space is not part of either program or data space. The Stack Pointer is readable and writable and the address on the top of the stack is readable and writable through the Top-of-Stack Special Function Registers. Data can also be pushed to, or popped from the stack, using these registers.

A CALL type instruction causes a push onto the stack. The Stack Pointer is first incremented and the location pointed to by the Stack Pointer is written with the contents of the PC (already pointing to the instruction following the CALL). A RETURN type instruction causes a pop from the stack. The contents of the location pointed to by the STKPTR are transferred to the PC and then the Stack Pointer is decremented.

The Stack Pointer is initialized to ‘00000’ after all Resets. There is no RAM associated with the location corresponding to a Stack Pointer value of ‘00000’; this is only a Reset value. Status bits indicate if the stack is full, has overflowed or has underflowed.

5.1.4.1 Top-of-Stack Access

Only the top of the return address stack (TOS) is readable and writable. A set of three registers, TOSU:TOSH:TOSL, holds the contents of the stack location pointed to by the STKPTR register (Figure 5-3). This allows users to implement a software stack if necessary. After a CALL, RCALL or interrupt (and ADDULNK and SUBULNK instructions if the extended instruction set is enabled), the software can read the pushed value by reading the TOSU:TOSH:TOSL registers. These values can be placed on a user-defined software stack. At return time, the software can return these values to TOSU:TOSH:TOSL and do a return.

The user must disable the global interrupt enable bits while accessing the stack to prevent inadvertent stack corruption.

FIGURE 5-3: RETURN ADDRESS STACK AND ASSOCIATED REGISTERS

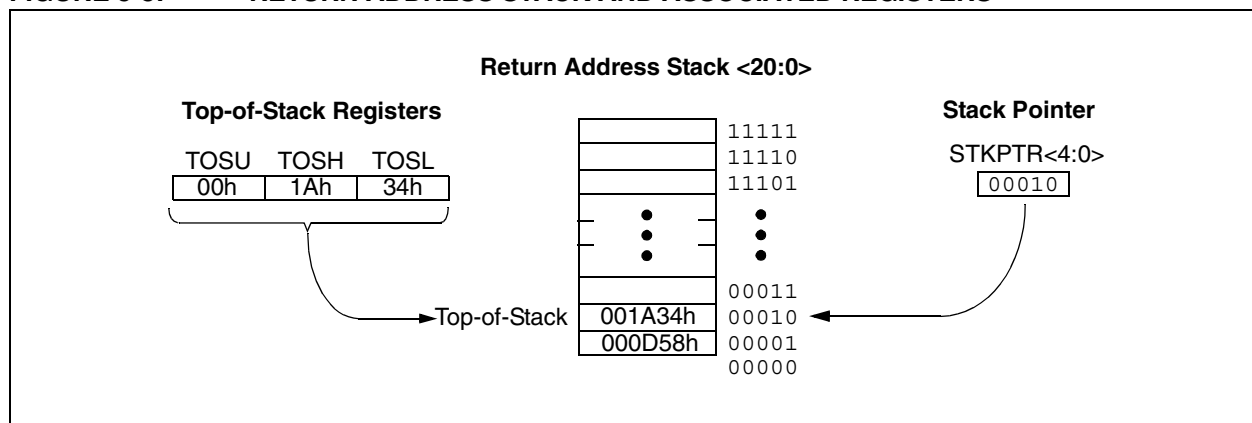

PIC18F85J90 FAMILY

5.1.4.2 Return Stack Pointer (STKPTR)

The STKPTR register (Register 5-1) contains the Stack Pointer value, the STKFUL (Stack Full) status bit and the STKUNF (Stack Underflow) status bits. The value of the Stack Pointer can be 0 through 31. The Stack Pointer increments before values are pushed onto the stack and decrements after values are popped off the stack. On Reset, the Stack Pointer value will be zero. The user may read and write the Stack Pointer value. This feature can be used by a Real-Time Operating System (RTOS) for return stack maintenance.

After the PC is pushed onto the stack 31 times (without popping any values off the stack), the STKFUL bit is set. The STKFUL bit is cleared by software or by a POR.

The action that takes place when the stack becomes full depends on the state of the STVREN (Stack Overflow Reset Enable) Configuration bit. (Refer to **Section 22.1 “Configuration Bits”** for a description of the device Configuration bits.) If STVREN is set (default), the 31st push will push the (PC + 2) value onto the stack, set the STKFUL bit and reset the device. The STKFUL bit will remain set and the Stack Pointer will be set to zero.

If STVREN is cleared, the STKFUL bit will be set on the 31st push and the Stack Pointer will increment to 31. Any additional pushes will not overwrite the 31st push and the STKPTR will remain at 31.

When the stack has been popped enough times to unload the stack, the next pop will return a value of zero to the PC and set the STKUNF bit, while the Stack Pointer remains at zero. The STKUNF bit will remain set until cleared by software or until a POR occurs.

Note: Returning a value of zero to the PC on an underflow has the effect of vectoring the program to the Reset vector, where the stack conditions can be verified and appropriate actions can be taken. This is not the same as a Reset, as the contents of the SFRs are not affected.

5.1.4.3 PUSH and POP Instructions

Since the Top-of-Stack is readable and writable, the ability to push values onto the stack and pull values off the stack, without disturbing normal program execution, is a desirable feature. The PIC18 instruction set includes two instructions, `PUSH` and `POP`, that permit the TOS to be manipulated under software control. TOSU, TOSH and TOSL can be modified to place data or a return address on the stack.

The `PUSH` instruction places the current PC value onto the stack. This increments the Stack Pointer and loads the current PC value onto the stack.

The `POP` instruction discards the current TOS by decrementing the Stack Pointer. The previous value pushed onto the stack then becomes the TOS value.

REGISTER 5-1: STKPTR: STACK POINTER REGISTER

R/C-0	R/C-0	U-0	R/W-0	R/W-0	R/W-0	R/W-0	R/W-0
STKFUL ⁽¹⁾	STKUNF ⁽¹⁾	—	SP4	SP3	SP2	SP1	SP0
bit 7							bit 0

Legend:	C = Clearable-only bit	U = Unimplemented bit, read as '0'
R = Readable bit	W = Writable bit	'0' = Bit is cleared
-n = Value at POR	'1' = Bit is set	x = Bit is unknown

- bit 7 **STKFUL:** Stack Full Flag bit⁽¹⁾
 1 = Stack became full or overflowed
 0 = Stack has not become full or overflowed
- bit 6 **STKUNF:** Stack Underflow Flag bit⁽¹⁾
 1 = Stack underflow occurred
 0 = Stack underflow did not occur
- bit 5 **Unimplemented:** Read as '0'
- bit 4-0 **SP4:SP0:** Stack Pointer Location bits

Note 1: Bit 7 and bit 6 are cleared by user software or by a POR.

PIC18F85J90 FAMILY

5.1.4.4 Stack Full and Underflow Resets

Device Resets on stack overflow and stack underflow conditions are enabled by setting the STVREN bit in Configuration Register 1L. When STVREN is set, a full or underflow condition will set the appropriate STKFUL or STKUNF bit and then cause a device Reset. When STVREN is cleared, a full or underflow condition will set the appropriate STKFUL or STKUNF bit, but not cause a device Reset. The STKFUL or STKUNF bits are cleared by the user software or a Power-on Reset.

5.1.5 FAST REGISTER STACK

A Fast Register Stack is provided for the STATUS, WREG and BSR registers to provide a “fast return” option for interrupts. This stack is only one level deep and is neither readable nor writable. It is loaded with the current value of the corresponding register when the processor vectors for an interrupt. All interrupt sources will push values into the Stack registers. The values in the registers are then loaded back into the working registers if the RETFIE, FAST instruction is used to return from the interrupt.

If both low and high priority interrupts are enabled, the Stack registers cannot be used reliably to return from low priority interrupts. If a high priority interrupt occurs while servicing a low priority interrupt, the Stack register values stored by the low priority interrupt will be overwritten. In these cases, users must save the key registers in software during a low priority interrupt.

If interrupt priority is not used, all interrupts may use the Fast Register Stack for returns from interrupt. If no interrupts are used, the Fast Register Stack can be used to restore the STATUS, WREG and BSR registers at the end of a subroutine call. To use the Fast Register Stack for a subroutine call, a CALL label, FAST instruction must be executed to save the STATUS, WREG and BSR registers to the Fast Register Stack. A RETURN, FAST instruction is then executed to restore these registers from the Fast Register Stack.

Example 5-1 shows a source code example that uses the Fast Register Stack during a subroutine call and return.

EXAMPLE 5-1: FAST REGISTER STACK CODE EXAMPLE

```
CALL SUB1, FAST      ;STATUS, WREG, BSR
                    ;SAVED IN FAST REGISTER
                    ;STACK
                    .
                    .
SUB1                 .
                    .
                    RETURN FAST      ;RESTORE VALUES SAVED
                                        ;IN FAST REGISTER STACK
```

5.1.6 LOOK-UP TABLES IN PROGRAM MEMORY

There may be programming situations that require the creation of data structures, or look-up tables, in program memory. For PIC18 devices, look-up tables can be implemented in two ways:

- Computed GOTO
- Table Reads

5.1.6.1 Computed GOTO

A computed GOTO is accomplished by adding an offset to the program counter. An example is shown in Example 5-2.

A look-up table can be formed with an ADDWF PCL instruction and a group of RETLW nn instructions. The W register is loaded with an offset into the table before executing a call to that table. The first instruction of the called routine is the ADDWF PCL instruction. The next instruction executed will be one of the RETLW nn instructions that returns the value ‘nn’ to the calling function.

The offset value (in WREG) specifies the number of bytes that the program counter should advance and should be multiples of 2 (LSb = 0).

In this method, only one data byte may be stored in each instruction location and room on the return address stack is required.

EXAMPLE 5-2: COMPUTED GOTO USING AN OFFSET VALUE

```
MOVWF  OFFSET, W
CALL   TABLE
ORG    nn00h
TABLE  ADDWF  PCL
        RETLW nnh
        RETLW nnh
        RETLW nnh
        .
        .
        .
```

5.1.6.2 Table Reads

A better method of storing data in program memory allows two bytes of data to be stored in each instruction location.

Look-up table data may be stored two bytes per program word while programming. The Table Pointer (TBLPTR) specifies the byte address and the Table Latch (TABLAT) contains the data that is read from the program memory. Data is transferred from program memory one byte at a time.

Table read operation is discussed further in Section 6.1 “Table Reads and Table Writes”.

PIC18F85J90 FAMILY

5.2 PIC18 Instruction Cycle

5.2.1 CLOCKING SCHEME

The microcontroller clock input, whether from an internal or external source, is internally divided by four to generate four non-overlapping quadrature clocks (Q1, Q2, Q3 and Q4). Internally, the program counter is incremented on every Q1; the instruction is fetched from the program memory and latched into the Instruction Register (IR) during Q4. The instruction is decoded and executed during the following Q1 through Q4. The clocks and instruction execution flow are shown in Figure 5-4.

5.2.2 INSTRUCTION FLOW/PIPELINING

An "Instruction Cycle" consists of four Q cycles, Q1 through Q4. The instruction fetch and execute are pipelined in such a manner that a fetch takes one instruction cycle, while the decode and execute take another instruction cycle. However, due to the pipelining, each instruction effectively executes in one cycle. If an instruction causes the program counter to change (e.g., GOTO), then two cycles are required to complete the instruction (Example 5-3).

A fetch cycle begins with the Program Counter (PC) incrementing in Q1.

In the execution cycle, the fetched instruction is latched into the Instruction Register (IR) in cycle Q1. This instruction is then decoded and executed during the Q2, Q3 and Q4 cycles. Data memory is read during Q2 (operand read) and written during Q4 (destination write).

FIGURE 5-4: CLOCK/INSTRUCTION CYCLE

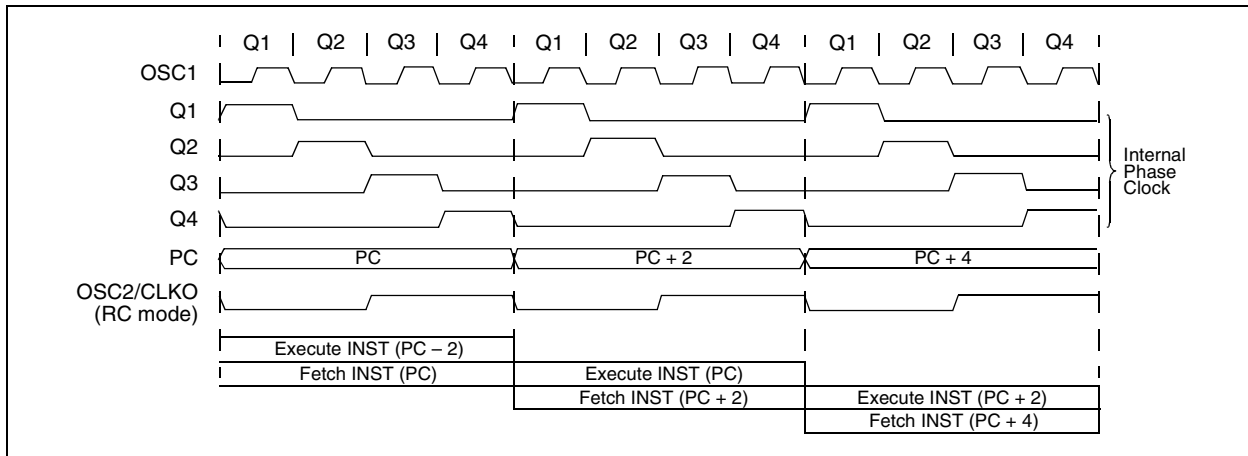

EXAMPLE 5-3: INSTRUCTION PIPELINE FLOW

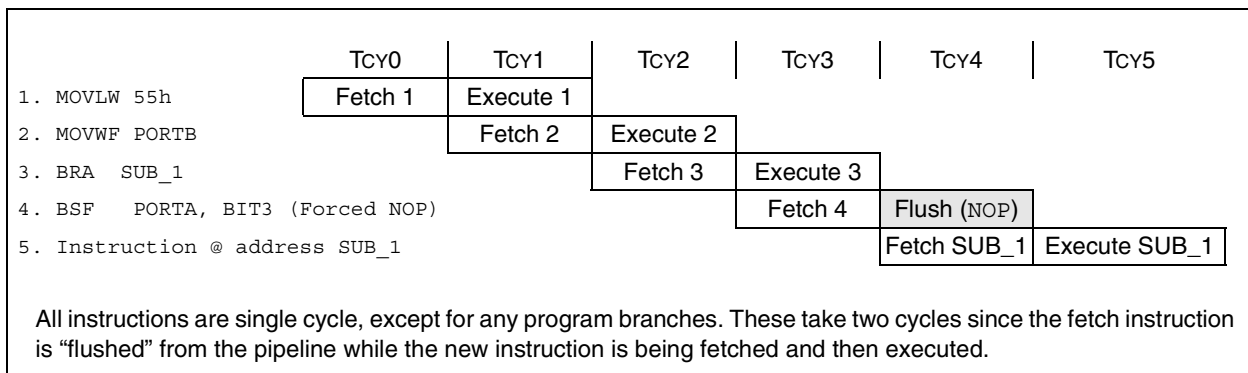

PIC18F85J90 FAMILY

5.2.3 INSTRUCTIONS IN PROGRAM MEMORY

The program memory is addressed in bytes. Instructions are stored as two bytes or four bytes in program memory. The Least Significant Byte of an instruction word is always stored in a program memory location with an even address (LSB = 0). To maintain alignment with instruction boundaries, the PC increments in steps of 2 and the LSB will always read '0' (see **Section 5.1.3 "Program Counter"**).

Figure 5-5 shows an example of how instruction words are stored in the program memory.

The CALL and GOTO instructions have the absolute program memory address embedded into the instruction. Since instructions are always stored on word boundaries, the data contained in the instruction is a word address. The word address is written to PC<20:1> which accesses the desired byte address in program memory. Instruction #2 in Figure 5-5 shows how the instruction, GOTO 0006h, is encoded in the program memory. Program branch instructions, which encode a relative address offset, operate in the same manner. The offset value stored in a branch instruction represents the number of single-word instructions that the PC will be offset by. **Section 23.0 "Instruction Set Summary"** provides further details of the instruction set.

FIGURE 5-5: INSTRUCTIONS IN PROGRAM MEMORY

Program Memory Byte Locations →			Word Address		
			LSB = 1	LSB = 0	
				000000h	
				000002h	
				000004h	
				000006h	
Instruction 1:	MOVLW	055h	0Fh	55h	000008h
Instruction 2:	GOTO	0006h	EFh	03h	00000Ah
			F0h	00h	00000Ch
Instruction 3:	MOVFF	123h, 456h	C1h	23h	00000Eh
			F4h	56h	000010h
					000012h
					000014h

5.2.4 TWO-WORD INSTRUCTIONS

The standard PIC18 instruction set has four two-word instructions: CALL, MOVFF, GOTO and LSRF. In all cases, the second word of the instructions always has '1111' as its four Most Significant bits; the other 12 bits are literal data, usually a data memory address.

The use of '1111' in the 4 MSBs of an instruction specifies a special form of NOP. If the instruction is executed in proper sequence – immediately after the first word – the data in the second word is accessed

and used by the instruction sequence. If the first word is skipped for some reason and the second word is executed by itself, a NOP is executed instead. This is necessary for cases when the two-word instruction is preceded by a conditional instruction that changes the PC. Example 5-4 shows how this works.

Note: See **Section 5.5 "Program Memory and the Extended Instruction Set"** for information on two-word instructions in the extended instruction set.

EXAMPLE 5-4: TWO-WORD INSTRUCTIONS

CASE 1:		
Object Code	Source Code	
0110 0110 0000 0000	TSTFSZ	REG1 ; is RAM location 0?
1100 0001 0010 0011	MOVFF	REG1, REG2 ; No, skip this word
1111 0100 0101 0110		; Execute this word as a NOP
0010 0100 0000 0000	ADDWF	REG3 ; continue code
CASE 2:		
Object Code	Source Code	
0110 0110 0000 0000	TSTFSZ	REG1 ; is RAM location 0?
1100 0001 0010 0011	MOVFF	REG1, REG2 ; Yes, execute this word
1111 0100 0101 0110		; 2nd word of instruction
0010 0100 0000 0000	ADDWF	REG3 ; continue code

PIC18F85J90 FAMILY

5.3 Data Memory Organization

Note: The operation of some aspects of data memory are changed when the PIC18 extended instruction set is enabled. See **Section 5.6 “Data Memory and the Extended Instruction Set”** for more information.

The data memory in PIC18 devices is implemented as static RAM. Each register in the data memory has a 12-bit address, allowing up to 4096 bytes of data memory. The memory space is divided into as many as 16 banks that contain 256 bytes each. The PIC18FX3J90/X4J90 devices, with up to 16 Kbytes of program memory, implement 4 complete banks for a total of 1024 bytes. PIC18FX5J90 devices, with 32 Kbytes of program memory, implement 8 complete banks for a total of 2048 bytes. Figure 5-6 and Figure 5-7 show the data memory organization for the devices.

The data memory contains Special Function Registers (SFRs) and General Purpose Registers (GPRs). The SFRs are used for control and status of the controller and peripheral functions, while GPRs are used for data storage and scratchpad operations in the user's application. Any read of an unimplemented location will read as '0's.

The instruction set and architecture allow operations across all banks. The entire data memory may be accessed by Direct, Indirect or Indexed Addressing modes. Addressing modes are discussed later in this section.

To ensure that commonly used registers (select SFRs and select GPRs) can be accessed in a single cycle, PIC18 devices implement an Access Bank. This is a 256-byte memory space that provides fast access to select SFRs and the lower portion of GPR Bank 0 without using the BSR. **Section 5.3.2 “Access Bank”** provides a detailed description of the Access RAM.

5.3.1 BANK SELECT REGISTER

Large areas of data memory require an efficient addressing scheme to make rapid access to any address possible. Ideally, this means that an entire address does not need to be provided for each read or write operation. For PIC18 devices, this is accomplished with a RAM banking scheme. This divides the memory space into 16 contiguous banks of 256 bytes. Depending on the instruction, each location can be addressed directly by its full 12-bit address, or an 8-bit low-order address and a 4-bit Bank Pointer.

Most instructions in the PIC18 instruction set make use of the Bank Pointer, known as the Bank Select Register (BSR). This SFR holds the 4 Most Significant bits of a location's address; the instruction itself includes the 8 Least Significant bits. Only the four lower bits of the BSR are implemented (BSR3:BSR0). The upper four bits are unused; they will always read '0' and cannot be written to. The BSR can be loaded directly by using the `MOVLB` instruction.

The value of the BSR indicates the bank in data memory. The 8 bits in the instruction show the location in the bank and can be thought of as an offset from the bank's lower boundary. The relationship between the BSR's value and the bank division in data memory is shown in Figure 5-8.

Since up to 16 registers may share the same low-order address, the user must always be careful to ensure that the proper bank is selected before performing a data read or write. For example, writing what should be program data to an 8-bit address of F9h while the BSR is 0Fh, will end up resetting the program counter.

While any bank can be selected, only those banks that are actually implemented can be read or written to. Writes to unimplemented banks are ignored, while reads from unimplemented banks will return '0's. Even so, the STATUS register will still be affected as if the operation was successful. The data memory map in Figure 5-6 indicates which banks are implemented.

In the core PIC18 instruction set, only the `MOVFF` instruction fully specifies the 12-bit address of the source and target registers. This instruction ignores the BSR completely when it executes. All other instructions include only the low-order address as an operand and must use either the BSR or the Access Bank to locate their target registers.

PIC18F85J90 FAMILY

FIGURE 5-6: DATA MEMORY MAP FOR PIC18FX3J90/X4J90 DEVICES

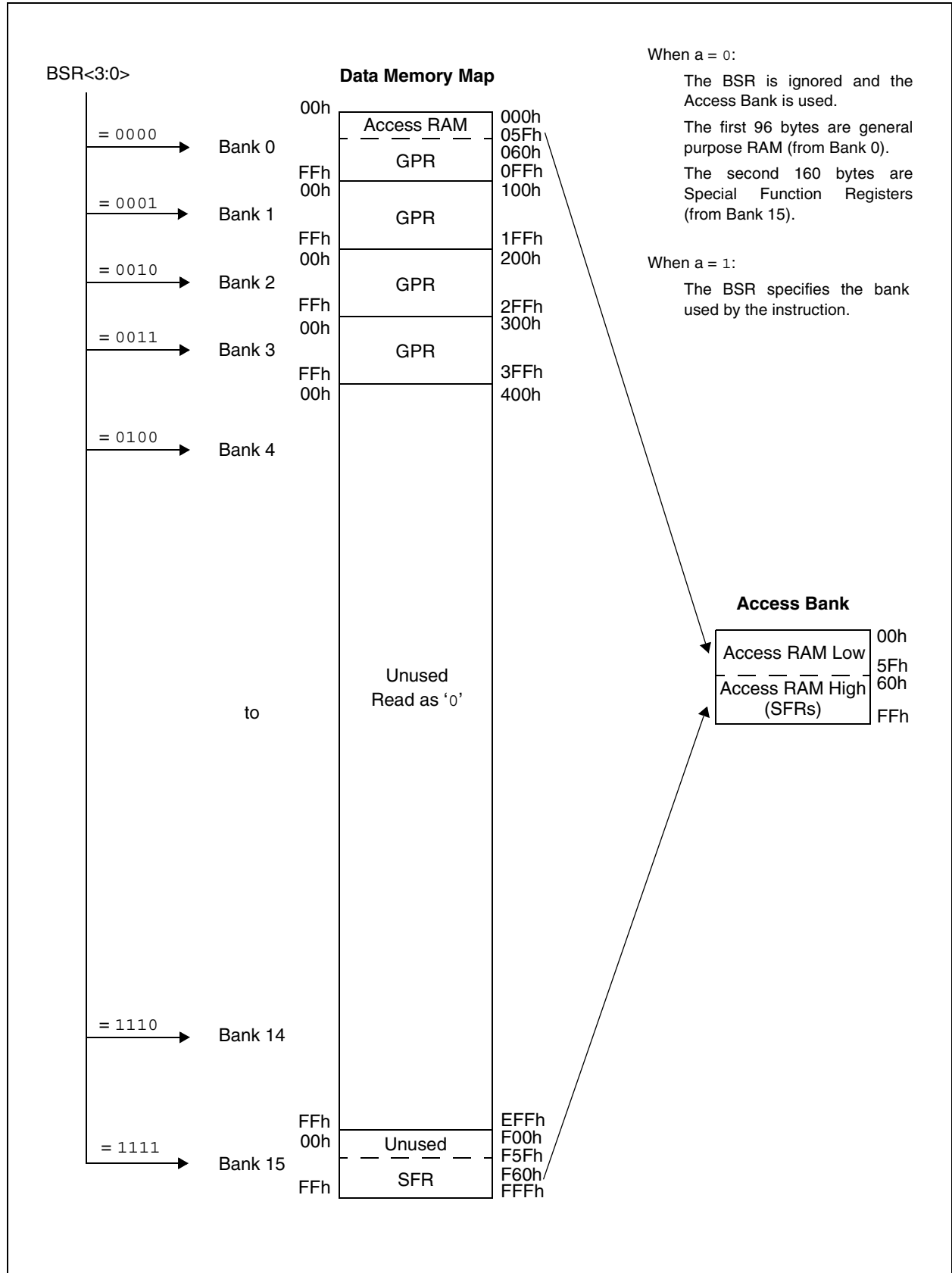
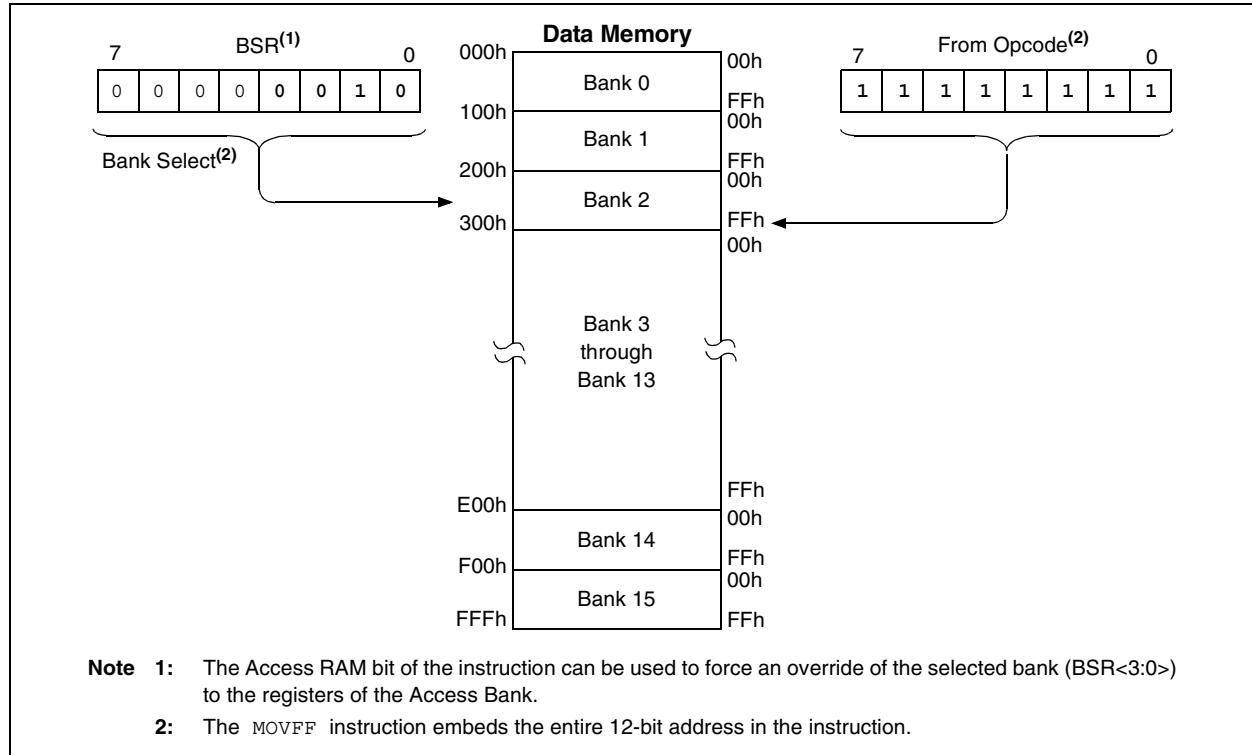

FIGURE 5-8: USE OF THE BANK SELECT REGISTER (DIRECT ADDRESSING)



5.3.2 ACCESS BANK

While the use of the BSR with an embedded 8-bit address allows users to address the entire range of data memory, it also means that the user must always ensure that the correct bank is selected. Otherwise, data may be read from, or written to, the wrong location. This can be disastrous if a GPR is the intended target of an operation, but an SFR is written to instead. Verifying and/or changing the BSR for each read or write to data memory can become very inefficient.

To streamline access for the most commonly used data memory locations, the data memory is configured with an Access Bank, which allows users to access a mapped block of memory without specifying a BSR. The Access Bank consists of the first 96 bytes of memory (00h-5Fh) in Bank 0 and the last 160 bytes of memory (60h-FFh) in Bank 15. The lower half is known as the “Access RAM” and is composed of GPRs. The upper half is where the device’s SFRs are mapped. These two areas are mapped contiguously in the Access Bank and can be addressed in a linear fashion by an 8-bit address (Figure 5-6).

The Access Bank is used by core PIC18 instructions that include the Access RAM bit (the ‘a’ parameter in the instruction). When ‘a’ is equal to ‘1’, the instruction uses the BSR and the 8-bit address included in the opcode for the data memory address. When ‘a’ is ‘0’,

however, the instruction is forced to use the Access Bank address map; the current value of the BSR is ignored entirely.

Using this “forced” addressing allows the instruction to operate on a data address in a single cycle without updating the BSR first. For 8-bit addresses of 60h and above, this means that users can evaluate and operate on SFRs more efficiently. The Access RAM below 60h is a good place for data values that the user might need to access rapidly, such as immediate computational results or common program variables. Access RAM also allows for faster and more code efficient context saving and switching of variables.

The mapping of the Access Bank is slightly different when the extended instruction set is enabled (XINST Configuration bit = 1). This is discussed in more detail in **Section 5.6.3 “Mapping the Access Bank in Indexed Literal Offset Mode”**.

5.3.3 GENERAL PURPOSE REGISTER FILE

PIC18 devices may have banked memory in the GPR area. This is data RAM which is available for use by all instructions. GPRs start at the bottom of Bank 0 (address 000h) and grow upwards towards the bottom of the SFR area. GPRs are not initialized by a Power-on Reset and are unchanged on all other Resets.

PIC18F85J90 FAMILY

5.3.4 SPECIAL FUNCTION REGISTERS

The Special Function Registers (SFRs) are registers used by the CPU and peripheral modules for controlling the desired operation of the device. These registers are implemented as static RAM. SFRs start at the top of data memory (FFFh) and extend downward to occupy more than the top half of Bank 15 (F60h to FFFh). A list of these registers is given in Table 5-2 and Table 5-3.

The SFRs can be classified into two sets: those associated with the “core” device functionality (ALU, Resets and interrupts) and those related to the peripheral functions. The Reset and Interrupt registers are described in their respective chapters, while the ALU’s STATUS register is described later in this section. Registers related to the operation of the peripheral features are described in the chapter for that peripheral.

The SFRs are typically distributed among the peripherals whose functions they control. Unused SFR locations are unimplemented and read as ‘0’s.

TABLE 5-2: SPECIAL FUNCTION REGISTER MAP FOR PIC18F85J90 FAMILY DEVICES

Address	Name	Address	Name	Address	Name	Address	Name	Address	Name
FFFh	TOSU	FDfH	INDF2 ⁽¹⁾	FBFh	LCDDATA4 ⁽³⁾	F9Fh	IPR1	F7Fh	SPBRGH1
FFEh	TOSH	FDEh	POSTINC2 ⁽¹⁾	FBEh	LCDDATA3	F9Eh	PIR1	F7Eh	BAUDCON1
FFDh	TOSL	FDDh	POSTDEC2 ⁽¹⁾	FBDh	LCDDATA2	F9Dh	PIE1	F7Dh	LCDDATA23 ⁽³⁾
FFCh	STKPTR	FDCh	PREINC2 ⁽¹⁾	FBCh	LCDDATA1	F9Ch	— ⁽²⁾	F7Ch	LCDDATA22 ⁽³⁾
FFBh	PCLATU	FDBh	PLUSW2 ⁽¹⁾	FBBh	LCDDATA0	F9Bh	OSCTUNE	F7Bh	LCDDATA21
FFAh	PCLATH	FDAh	FSR2H	FBAh	LCDSE5 ⁽³⁾	F9Ah	TRISJ ⁽³⁾	F7Ah	LCDDATA20
FF9h	PCL	FD9h	FSR2L	FB9h	LCDSE4 ⁽³⁾	F99h	TRISH ⁽³⁾	F79h	LCDDATA19
FF8h	TBLPTRU	FD8h	STATUS	FB8h	LCDSE3	F98h	TRISG	F78h	LCDDATA18
FF7h	TBLPTRH	FD7h	TMR0H	FB7h	LCDSE2	F97h	TRISF	F77h	LCDDATA17 ⁽³⁾
FF6h	TBLPTRL	FD6h	TMR0L	FB6h	LCDSE1	F96h	TRISE	F76h	LCDDATA16 ⁽³⁾
FF5h	TABLAT	FD5h	T0CON	FB5h	CVRCON	F95h	TRISD	F75h	LCDDATA15
FF4h	PRODH	FD4h	— ⁽²⁾	FB4h	CMCON	F94h	TRISC	F74h	LCDDATA14
FF3h	PRODL	FD3h	OSCCON	FB3h	TMR3H	F93h	TRISB	F73h	LCDDATA13
FF2h	INTCON	FD2h	LCDREG	FB2h	TMR3L	F92h	TRISA	F72h	LCDDATA12
FF1h	INTCON2	FD1h	WDTCON	FB1h	T3CON	F91h	LATJ ⁽³⁾	F71h	LCDDATA11 ⁽³⁾
FF0h	INTCON3	FD0h	RCON	FB0h	— ⁽²⁾	F90h	LATH ⁽³⁾	F70h	LCDDATA10 ⁽³⁾
FEFh	INDF0 ⁽¹⁾	FCFh	TMR1H	FAFh	SPBRG1	F8Fh	LATG	F6Fh	LCDDATA9
FEeh	POSTINC0 ⁽¹⁾	FCEh	TMR1L	FAeh	RCREG1	F8Eh	LATF	F6Eh	LCDDATA8
FEDh	POSTDEC0 ⁽¹⁾	FCDh	T1CON	FADh	TXREG1	F8Dh	LATE	F6Dh	LCDDATA7
FECh	PREINC0 ⁽¹⁾	FCCh	TMR2	FACH	TXSTA1	F8Ch	LATD	F6Ch	LCDDATA6
FEBh	PLUSW0 ⁽¹⁾	FCBh	PR2	FABh	RCSTA1	F8Bh	LATC	F6Bh	LCDDATA5 ⁽³⁾
FEAh	FSR0H	FCAh	T2CON	FAAh	LCDPS	F8Ah	LATB	F6Ah	CCPR1H
FE9h	FSR0L	FC9h	SSPBUF	FA9h	LCDSE0	F89h	LATA	F69h	CCPR1L
FE8h	WREG	FC8h	SSPADD	FA8h	LCDCON	F88h	PORTJ ⁽³⁾	F68h	CCP1CON
FE7h	INDF1 ⁽¹⁾	FC7h	SSPSTAT	FA7h	EECON2	F87h	PORTH ⁽³⁾	F67h	CCPR2H
FE6h	POSTINC1 ⁽¹⁾	FC6h	SSPCON1	FA6h	EECON1	F86h	PORTG	F66h	CCPR2L
FE5h	POSTDEC1 ⁽¹⁾	FC5h	SSPCON2	FA5h	IPR3	F85h	PORTF	F65h	CCP2CON
FE4h	PREINC1 ⁽¹⁾	FC4h	ADRESH	FA4h	PIR3	F84h	PORTE	F64h	SPBRG2
FE3h	PLUSW1 ⁽¹⁾	FC3h	ADRESL	FA3h	PIE3	F83h	PORTD	F63h	RCREG2
FE2h	FSR1H	FC2h	ADCON0	FA2h	IPR2	F82h	PORTC	F62h	TXREG2
FE1h	FSR1L	FC1h	ADCON1	FA1h	PIR2	F81h	PORTB	F61h	TXSTA2
FE0h	BSR	FC0h	ADCON2	FA0h	PIE2	F80h	PORTA	F60h	RCSTA2

- Note** 1: This is not a physical register.
 2: Unimplemented registers are read as ‘0’.
 3: This register is not available on 64-pin devices.

PIC18F85J90 FAMILY

TABLE 5-3: PIC18F85J90 FAMILY REGISTER FILE SUMMARY

Filename	Bit 7	Bit 6	Bit 5	Bit 4	Bit 3	Bit 2	Bit 1	Bit 0	Value on POR, BOR	Details on page		
TOSU	—	—	—	Top-of-Stack Upper Byte (TOS<20:16>)					---0 0000	51, 59		
TOSH	Top-of-Stack High Byte (TOS<15:8>)								0000 0000	51, 59		
TOSL	Top-of-Stack Low Byte (TOS<7:0>)								0000 0000	51, 59		
STKPTR	STKFUL	STKUNF	—	Return Stack Pointer					uu-0 0000	51, 60		
PCLATU	—	—	bit 21 ⁽¹⁾	Holding Register for PC<20:16>							---0 0000	51, 59
PCLATH	Holding Register for PC<15:8>								0000 0000	51, 59		
PCL	PC Low Byte (PC<7:0>)								0000 0000	51, 59		
TBLPTRU	—	—	bit 21	Program Memory Table Pointer Upper Byte (TBLPTR<20:16>)							--00 0000	51, 84
TBLPTRH	Program Memory Table Pointer High Byte (TBLPTR<15:8>)								0000 0000	51, 84		
TBLPTRL	Program Memory Table Pointer Low Byte (TBLPTR<7:0>)								0000 0000	51, 84		
TABLAT	Program Memory Table Latch								0000 0000	51, 84		
PRODH	Product Register High Byte								xxxx xxxx	51, 91		
PRODL	Product Register Low Byte								xxxx xxxx	51, 91		
INTCON	GIE/GIEH	PEIE/GIEL	TMR0IE	INT0IE	RBIE	TMR0IF	INT0IF	RBIF	0000 000x	51, 95		
INTCON2	RBPU	INTEDG0	INTEDG1	INTEDG2	INTEDG3	TMR0IP	INT3IP	RBIP	1111 1111	51, 96		
INTCON3	INT2IP	INT1IP	INT3IE	INT2IE	INT1IE	INT3IF	INT2IF	INT1IF	1100 0000	51, 97		
INDF0	Uses contents of FSR0 to address data memory – value of FSR0 not changed (not a physical register)								N/A	51, 75		
POSTINC0	Uses contents of FSR0 to address data memory – value of FSR0 post-incremented (not a physical register)								N/A	51, 76		
POSTDEC0	Uses contents of FSR0 to address data memory – value of FSR0 post-decremented (not a physical register)								N/A	51, 76		
PREINC0	Uses contents of FSR0 to address data memory – value of FSR0 pre-incremented (not a physical register)								N/A	51, 76		
PLUSW0	Uses contents of FSR0 to address data memory – value of FSR0 pre-incremented (not a physical register) – value of FSR0 offset by W								N/A	51, 76		
FSR0H	—	—	—	—	Indirect Data Memory Address Pointer 0 High				---- xxxxx	51, 75		
FSR0L	Indirect Data Memory Address Pointer 0 Low Byte								xxxx xxxxx	51, 75		
WREG	Working Register								xxxx xxxxx	51		
INDF1	Uses contents of FSR1 to address data memory – value of FSR1 not changed (not a physical register)								N/A	51, 75		
POSTINC1	Uses contents of FSR1 to address data memory – value of FSR1 post-incremented (not a physical register)								N/A	51, 76		
POSTDEC1	Uses contents of FSR1 to address data memory – value of FSR1 post-decremented (not a physical register)								N/A	51, 76		
PREINC1	Uses contents of FSR1 to address data memory – value of FSR1 pre-incremented (not a physical register)								N/A	51, 76		
PLUSW1	Uses contents of FSR1 to address data memory – value of FSR1 pre-incremented (not a physical register) – value of FSR1 offset by W								N/A	51, 76		
FSR1H	—	—	—	—	Indirect Data Memory Address Pointer 1 High Byte				---- xxxxx	52, 75		
FSR1L	Indirect Data Memory Address Pointer 1 Low Byte								xxxx xxxxx	52, 75		
BSR	—	—	—	—	Bank Select Register				---- 0000	52, 64		
INDF2	Uses contents of FSR2 to address data memory – value of FSR2 not changed (not a physical register)								N/A	52, 75		
POSTINC2	Uses contents of FSR2 to address data memory – value of FSR2 post-incremented (not a physical register)								N/A	52, 76		
POSTDEC2	Uses contents of FSR2 to address data memory – value of FSR2 post-decremented (not a physical register)								N/A	52, 76		
PREINC2	Uses contents of FSR2 to address data memory – value of FSR2 pre-incremented (not a physical register)								N/A	52, 76		
PLUSW2	Uses contents of FSR2 to address data memory – value of FSR2 pre-incremented (not a physical register) – value of FSR2 offset by W								N/A	52, 76		
FSR2H	—	—	—	—	Indirect Data Memory Address Pointer 2 High Byte				---- xxxxx	52, 75		
FSR2L	Indirect Data Memory Address Pointer 2 Low Byte								xxxx xxxxx	52, 75		
STATUS	—	—	—	N	OV	Z	DC	C	---x xxxxx	52, 73		

Legend: x = unknown, u = unchanged, - = unimplemented, q = value depends on condition, r = reserved, do not modify

Note 1: Bit 21 of the PC is only available in Test mode and Serial Programming modes.

- 2:** These registers and/or bits are available only on 80-pin devices; otherwise they are unimplemented and read as '0'. Reset states shown are for 80-pin devices.
- 3:** Alternate names and definitions for these bits when the MSSP module is operating in I²C™ Slave mode. See **Section 16.4.3.2 “Address Masking”** for details.
- 4:** The PLLEN bit is only available in specific oscillator configurations; otherwise it is disabled and reads as '0'. See **Section 2.4.3 “PLL Frequency Multiplier”** for details.
- 5:** RA6/RA7 and their associated latch and direction bits are configured as port pins only when the internal oscillator is selected as the default clock source (FOSC2 Configuration bit = 0); otherwise, they are disabled and these bits read as '0'.

PIC18F85J90 FAMILY

TABLE 5-3: PIC18F85J90 FAMILY REGISTER FILE SUMMARY (CONTINUED)

Filename	Bit 7	Bit 6	Bit 5	Bit 4	Bit 3	Bit 2	Bit 1	Bit 0	Value on POR, BOR	Details on page
TMR0H	Timer0 Register High Byte								0000 0000	52, 133
TMR0L	Timer0 Register Low Byte								xxxx xxxx	52, 133
T0CON	TMR0ON	T08BIT	T0CS	T0SE	PSA	T0PS2	T0PS1	T0PS0	1111 1111	52, 131
OSCCON	IDLEN	IRCF2	IRCF1	IRCF0	OSTS	IOFS	SCS1	SCS0	0100 q000	30, 52
LCDREG	—	CPEN	BIAS2	BIAS1	BIAS0	MODE13	CKSEL1	CKSEL0	-011 1100	52, 163
WDTCON	REGSLP	—	—	—	—	—	—	SWDTEN	0--- --0	52, 289
RCON	IPEN	—	—	RI	TO	PD	POR	BOR	0--1 11q0	46, 52
TMR1H	Timer1 Register High Byte								xxxx xxxx	52, 139
TMR1L	Timer1 Register Low Byte								xxxx xxxx	52, 139
T1CON	RD16	T1RUN	T1CKPS1	T1CKPS0	T1OSCEN	T1SYN \bar{C}	TMR1CS	TMR1ON	0000 0000	52, 135
TMR2	Timer2 Register								0000 0000	52, 142
PR2	Timer2 Period Register								1111 1111	52, 142
T2CON	—	T2OUTPS3	T2OUTPS2	T2OUTPS1	T2OUTPS0	TMR2ON	T2CKPS1	T2CKPS0	-000 0000	52, 141
SSPBUF	MSSP Receive Buffer/Transmit Register								xxxx xxxx	52, 193, 228
SSPADD	MSSP Address Register in I ² C™ Slave mode. MSSP1 Baud Rate Reload Register in I ² C Master mode.								0000 0000	52, 228
SSPSTAT	SMP	CKE	D/A	P	S	R/W	UA	BF	0000 0000	52, 186, 195
SSPCON1	WCOL	SSPOV	SSPEN	CKP	SSPM3	SSPM2	SSPM1	SSPM0	0000 0000	52, 187, 196
SSPCON2	GCEN	ACKSTAT	ACKDT	ACKEN	RCEN	PEN	RSEN	SEN	0000 0000	52, 197, 198
	GCEN	ACKSTAT	ADMSK5 ⁽³⁾	ADMSK4 ⁽³⁾	ADMSK3 ⁽³⁾	ADMSK2 ⁽³⁾	ADMSK1 ⁽³⁾	SEN		
ADRESH	A/D Result Register High Byte								xxxx xxxx	53, 271
ADRESL	A/D Result Register Low Byte								xxxx xxxx	53, 271
ADCON0	ADCAL	—	CHS3	CHS2	CHS1	CHS0	GO/DONE	ADON	0-00 0000	53, 263
ADCON1	—	—	VCFG1	VCFG0	PCFG3	PCFG2	PCFG1	PCFG0	--00 0000	53, 264
ADCON2	ADFM	—	ACQT2	ACQT1	ACQT0	ADCS2	ADCS1	ADCS0	0-00 0000	53, 265
LCDATA4	S39C0 ⁽²⁾	S38C0 ⁽²⁾	S37C0 ⁽²⁾	S36C0 ⁽²⁾	S35C0 ⁽²⁾	S34C0 ⁽²⁾	S33C0 ⁽²⁾	S32C0	xxxx xxxx	53, 161
LCDATA3	S31C0	S30C0	S29C0	S28C0	S27C0	S26C0	S25C0	S24C0	xxxx xxxx	53, 161
LCDATA2	S23C0	S22C0	S21C0	S20C0	S19C0	S18C0	S17C0	S16C0	xxxx xxxx	53, 161
LCDATA1	S15C0	S14C0	S13C0	S12C0	S11C0	S10C0	S09C0	S08C0	xxxx xxxx	53, 161
LCDATA0	S07C0	S06C0	S05C0	S04C0	S03C0	S02C0	S01C0	S00C0	xxxx xxxx	53, 161
LCDSE5 ⁽²⁾	SE47	SE46	SE45	SE44	SE43	SE42	SE41	SE40	0000 0000	53, 160
LCDSE4	SE39 ⁽²⁾	SE38 ⁽²⁾	SE37 ⁽²⁾	SE36 ⁽²⁾	SE35 ⁽²⁾	SE34 ⁽²⁾	SE33 ⁽²⁾	SE32	0000 0000	53, 160
LCDSE3	SE31	SE30	SE29	SE28	SE27	SE26	SE25	SE24	0000 0000	53, 160
LCDSE2	SE23	SE22	SE21	SE20	SE19	SE18	SE17	SE16	0000 0000	53, 160
LCDSE1	SE15	SE14	SE13	SE12	SE11	SE10	SE09	SE08	0000 0000	53, 160
CVRCON	CVREN	CVROE	CVRR	CVRSS	CVR3	CVR2	CVR1	CVR0	0000 0000	53, 279
CMCON	C2OUT	C1OUT	C2INV	C1INV	CIS	CM2	CM1	CM0	0000 0111	53, 273
TMR3H	Timer3 Register High Byte								xxxx xxxx	53, 145
TMR3L	Timer3 Register Low Byte								xxxx xxxx	53, 145
T3CON	RD16	T3CCP2	T3CKPS1	T3CKPS0	T3CCP1	T3SYN \bar{C}	TMR3CS	TMR3ON	0000 0000	53, 143

Legend: x = unknown, u = unchanged, - = unimplemented, q = value depends on condition, r = reserved, do not modify

Note 1: Bit 21 of the PC is only available in Test mode and Serial Programming modes.

2: These registers and/or bits are available only on 80-pin devices; otherwise they are unimplemented and read as '0'. Reset states shown are for 80-pin devices.

3: Alternate names and definitions for these bits when the MSSP module is operating in I²C™ Slave mode. See **Section 16.4.3.2 "Address Masking"** for details.

4: The PLEN bit is only available in specific oscillator configurations; otherwise it is disabled and reads as '0'. See **Section 2.4.3 "PLL Frequency Multiplier"** for details.

5: RA6/RA7 and their associated latch and direction bits are configured as port pins only when the internal oscillator is selected as the default clock source (FOSC2 Configuration bit = 0); otherwise, they are disabled and these bits read as '0'.

PIC18F85J90 FAMILY

TABLE 5-3: PIC18F85J90 FAMILY REGISTER FILE SUMMARY (CONTINUED)

Filename	Bit 7	Bit 6	Bit 5	Bit 4	Bit 3	Bit 2	Bit 1	Bit 0	Value on POR, BOR	Details on page
SPBRG1	EUSART Baud Rate Generator								0000 0000	53, 233
RCREG1	EUSART Receive Register								0000 0000	53, 241
TXREG1	EUSART Transmit Register								0000 0000	53, 239
TXSTA1	CSRC	TX9	TXEN	SYNC	SENDB	BRGH	TRMT	TX9D	0000 0010	53, 230
RCSTA1	SPEN	RX9	SREN	CREN	ADDEN	FERR	OERR	RX9D	0000 000x	53, 231
LCDPS	WFT	BIASMD	LCDA	WA	LP3	LP2	LP1	LP0	0000 0000	53, 159
LCDSE0	SE07	SE06	SE05	SE04	SE03	SE02	SE01	SE00	0000 0000	53, 160
LCDCON	LCDEN	SLPEN	WERR	—	CS1	CS0	LMUX1	LMUX0	000- 0000	53, 158
EECON2	EEPROM Control Register 2 (not a physical register)								---- ----	53, 82
EECON1	—	—	—	FREE	WRERR	WREN	WR	—	---0 x00-	53, 83
IPR3	—	LCDIP	RC2IP	TX2IP	—	CCP2IP	CCP1IP	—	-111 -11-	54, 106
PIR3	—	LCDIF	RC2IF	TX2IF	—	CCP2IF	CCP1IF	—	-000 -00-	54, 100
PIE3	—	LCDIE	RC2IE	TX2IE	—	CCP2IE	CCP1IE	—	-000 -00-	54, 103
IPR2	OSCFIP	CMIP	—	—	BCLIP	LVDIP	TMR3IP	—	11-- 111-	54, 105
PIR2	OSCFIF	CMIF	—	—	BCLIF	LVDIF	TMR3IF	—	00-- 000-	54, 99
PIE2	OSCFIE	CMIE	—	—	BCLIE	LVDIE	TMR3IE	—	00-- 000-	54, 102
IPR1	—	ADIP	RC1IP	TX1IP	SSPIP	—	TMR2IP	TMR1IP	-111 1-11	54, 104
PIR1	—	ADIF	RC1IF	TX1IF	SSPIF	—	TMR2IF	TMR1IF	-000 0-00	54, 98
PIE1	—	ADIE	RC1IE	TX1IE	SSPIE	—	TMR2IE	TMR1IE	-000 0-00	54, 101
OSCTUNE	INTSRC	PLLEN ⁽⁴⁾	TUN5	TUN4	TUN3	TUN2	TUN1	TUN0	0000 0000	31, 54
TRISJ ⁽²⁾	TRISJ7	TRISJ6	TRISJ5	TRISJ4	TRISJ3	TRISJ2	TRISJ1	TRISJ0	1111 1111	54, 130
TRISH ⁽²⁾	TRISH7	TRISH6	TRISH5	TRISH4	TRISH3	TRISH2	TRISH1	TRISH0	1111 1111	54, 128
TRISG	SPIOD	CCP2OD	CCP1OD	TRISG4	TRISG3	TRISG2	TRISG1	TRISG0	0001 1111	54, 126
TRISF	TRISF7	TRISF6	TRISF5	TRISF4	TRISF3	TRISF2	TRISF1	—	1111 111-	54, 124
TRISE	TRISE7	TRISE6	TRISE5	TRISE4	TRISE3	—	TRISE1	TRISE0	1111 1-11	54, 121
TRISD	TRISD7	TRISD6	TRISD5	TRISD4	TRISD3	TRISD2	TRISD1	TRISD0	1111 1111	54, 119
TRISC	TRISC7	TRISC6	TRISC5	TRISC4	TRISC3	TRISC2	TRISC1	TRISC0	1111 1111	54, 117
TRISB	TRISB7	TRISB6	TRISB5	TRISB4	TRISB3	TRISB2	TRISB1	TRISB0	1111 1111	54, 114
TRISA	TRISA7 ⁽⁵⁾	TRISA6 ⁽⁵⁾	TRISA5	TRISA4	TRISA3	TRISA2	TRISA1	TRISA0	1111 1111	54, 111
LATJ ⁽²⁾	LATJ7	LATJ6	LATJ5	LATJ4	LATJ3	LATJ2	LATJ1	LATJ0	xxxx xxxx	54, 130
LATH ⁽²⁾	LATH7	LATH6	LATH5	LATH4	LATH3	LATH2	LATH1	LATH0	xxxx xxxx	54, 128
LATG	U2OD	U1OD	—	LATG4	LATG3	LATG2	LATG1	LATG0	00-x xxxxx	54, 126
LATF	LATF7	LATF6	LATF5	LATF4	LATF3	LATF2	LATF1	—	xxxx xxx-	54, 124
LATE	LATE7	LATE6	LATE5	LATE4	LATE3	—	LATE1	LATE0	xxxx x-xx	54, 121
LATD	LATD7	LATD6	LATD5	LATD4	LATD3	LATD2	LATD1	LATD0	xxxx xxxxx	54, 119
LATC	LATC7	LATC6	LATC5	LATC4	LATC3	LATC2	LATC1	LATC0	xxxx xxxxx	54, 117
LATB	LATB7	LATB6	LATB5	LATB4	LATB3	LATB2	LATB1	LATB0	xxxx xxxxx	54, 114
LATA	LATA7 ⁽⁵⁾	LATA6 ⁽⁵⁾	LATA5	LATA4	LATA3	LATA2	LATA1	LATA0	xxxx xxxxx	54, 111

Legend: x = unknown, u = unchanged, - = unimplemented, q = value depends on condition, r = reserved, do not modify

Note 1: Bit 21 of the PC is only available in Test mode and Serial Programming modes.

- 2: These registers and/or bits are available only on 80-pin devices; otherwise they are unimplemented and read as '0'. Reset states shown are for 80-pin devices.
- 3: Alternate names and definitions for these bits when the MSSP module is operating in I²C™ Slave mode. See **Section 16.4.3.2 "Address Masking"** for details.
- 4: The PLLEN bit is only available in specific oscillator configurations; otherwise it is disabled and reads as '0'. See **Section 2.4.3 "PLL Frequency Multiplier"** for details.
- 5: RA6/RA7 and their associated latch and direction bits are configured as port pins only when the internal oscillator is selected as the default clock source (FOSC2 Configuration bit = 0); otherwise, they are disabled and these bits read as '0'.

PIC18F85J90 FAMILY

TABLE 5-3: PIC18F85J90 FAMILY REGISTER FILE SUMMARY (CONTINUED)

Filename	Bit 7	Bit 6	Bit 5	Bit 4	Bit 3	Bit 2	Bit 1	Bit 0	Value on POR, BOR	Details on page
PORTJ ⁽²⁾	RJ7	RJ6	RJ5	RJ4	RJ3	RJ2	RJ1	RJ0	xxxx xxxx	54, 130
PORTh ⁽²⁾	RH7	RH6	RH5	RH4	RH3	RH2	RH1	RH0	xxxx xxxx	54, 128
PORTG	RDPU	REPU	RJPU ⁽²⁾	RG4	RG3	RG2	RG1	RG0	000x xxxx	54, 126
PORTF	RF7	RF6	RF5	RF4	RF3	RF2	RF1	—	xxxx xxx-	54, 124
PORTE	RE7	RE6	RE5	RE4	RE3	—	RE1	RE0	xxxx x-xx	55, 121
PORTD	RD7	RD6	RD5	RD4	RD3	RD2	RD1	RD0	xxxx xxxx	55, 119
PORTC	RC7	RC6	RC5	RC4	RC3	RC2	RC1	RC0	xxxx xxxx	55, 117
PORTB	RB7	RB6	RB5	RB4	RB3	RB2	RB1	RB0	xxxx xxxx	55, 114
PORTA	RA7 ⁽⁵⁾	RA6 ⁽⁵⁾	RA5	RA4	RA3	RA2	RA1	RA0	xx0x 0000	55, 111
SPBRGH1	EUSART Baud Rate Generator High Byte								0000 0000	55, 233
BAUDCON1	ABDOVF	RCMT	—	SCKP	BRG16	—	WUE	ABDEN	01-0 0-00	55, 232
LCDDATA23 ⁽²⁾	S47C3	S46C3	S45C3	S44C3	S43C3	S42C3	S41C3	S40C3	xxxx xxxx	55, 161
LCDDATA22	S39C3 ⁽²⁾	S38C3 ⁽²⁾	S37C3 ⁽²⁾	S36C3 ⁽²⁾	S35C3 ⁽²⁾	S34C3 ⁽²⁾	S33C3 ⁽²⁾	S32C3	xxxx xxxx	55, 161
LCDDATA21	S31C3	S30C3	S29C3	S28C3	S27C3	S26C3	S25C3	S24C3	xxxx xxxx	55, 161
LCDDATA20	S23C3	S22C3	S21C3	S20C3	S19C3	S18C3	S17C3	S16C3	xxxx xxxx	55, 161
LCDDATA19	S15C3	S14C3	S13C3	S12C3	S11C3	S10C3	S09C3	S08C3	xxxx xxxx	55, 161
LCDDATA18	S07C3	S06C3	S05C3	S04C3	S03C3	S02C3	S01C3	S00C3	xxxx xxxx	55, 161
LCDDATA17 ⁽²⁾	S47C2	S46C2	S45C2	S44C2	S43C2	S42C2	S41C2	S40C2	xxxx xxxx	55, 161
LCDDATA16	S39C2 ⁽²⁾	S38C2 ⁽²⁾	S37C2 ⁽²⁾	S36C2 ⁽²⁾	S35C2 ⁽²⁾	S34C2 ⁽²⁾	S33C2 ⁽²⁾	S32C2	xxxx xxxx	55, 161
LCDDATA15	S31C2	S30C2	S29C2	S28C2	S27C2	S26C2	S25C2	S24C2	xxxx xxxx	55, 161
LCDDATA14	S23C2	S22C2	S21C2	S20C2	S19C2	S18C2	S17C2	S16C2	xxxx xxxx	55, 161
LCDDATA13	S15C2	S14C2	S13C2	S12C2	S11C2	S10C2	S09C2	S08C2	xxxx xxxx	55, 161
LCDDATA12	S07C2	S06C2	S05C2	S04C2	S03C2	S02C2	S01C2	S00C2	xxxx xxxx	55, 161
LCDDATA11 ⁽²⁾	S47C1	S46C1	S45C1	S44C1	S43C1	S42C1	S41C1	S40C1	xxxx xxxx	55, 161
LCDDATA10	S39C1 ⁽²⁾	S38C1 ⁽²⁾	S37C1 ⁽²⁾	S36C1 ⁽²⁾	S35C1 ⁽²⁾	S34C1 ⁽²⁾	S33C1 ⁽²⁾	S32C1	xxxx xxxx	55, 161
LCDDATA9	S31C1	S30C1	S29C1	S28C1	S27C1	S26C1	S25C1	S24C1	xxxx xxxx	55, 161
LCDDATA8	S23C1	S22C1	S21C1	S20C1	S19C1	S18C1	S17C1	S16C1	xxxx xxxx	55, 161
LCDDATA7	S15C1	S14C1	S13C1	S12C1	S11C1	S10C1	S09C1	S08C1	xxxx xxxx	55, 161
LCDDATA6	S07C1	S06C1	S05C1	S04C1	S03C1	S02C1	S01C1	S00C1	xxxx xxxx	55, 161
LCDDATA5 ⁽²⁾	S47C0	S46C0	S45C0	S44C0	S43C0	S42C0	S41C0	S40C0	xxxx xxxx	55, 161
CCPR1H	Capture/Compare/PWM Register 1 High Byte								xxxx xxxx	55, 148
CCPR1L	Capture/Compare/PWM Register 1 Low Byte								xxxx xxxx	55, 148
CCP1CON	—	—	DC1B1	DC1B0	CCP1M3	CCP1M2	CCP1M1	CCP1M0	--00 0000	55, 147
CCPR2H	Capture/Compare/PWM Register 2 High Byte								xxxx xxxx	55, 148
CCPR2L	Capture/Compare/PWM Register 2 Low Byte								xxxx xxxx	56, 148
CCP2CON	—	—	DC2B1	DC2B0	CCP2M3	CCP2M2	CCP2M1	CCP2M0	--00 0000	56, 147
SPBRG2	AUSART Baud Rate Generator Register								0000 0000	56, 252
RCREG2	AUSART Receive Register								0000 0000	56, 257
TXREG2	AUSART Transmit Register								0000 0000	56, 255
TXSTA2	CSRC	TX9	TXEN	SYNC	—	BRGH	TRMT	TX9D	0000 -010	56, 250
RCSTA2	SPEN	RX9	SREN	CREN	ADDEN	FERR	OERR	RX9D	0000 000x	56, 251

Legend: x = unknown, u = unchanged, - = unimplemented, q = value depends on condition, r = reserved, do not modify

Note 1: Bit 21 of the PC is only available in Test mode and Serial Programming modes.

2: These registers and/or bits are available only on 80-pin devices; otherwise they are unimplemented and read as '0'. Reset states shown are for 80-pin devices.

3: Alternate names and definitions for these bits when the MSSP module is operating in I²C™ Slave mode. See **Section 16.4.3.2 "Address Masking"** for details.

4: The PLEN bit is only available in specific oscillator configurations; otherwise it is disabled and reads as '0'. See **Section 2.4.3 "PLL Frequency Multiplier"** for details.

5: RA6/RA7 and their associated latch and direction bits are configured as port pins only when the internal oscillator is selected as the default clock source (FOSC2 Configuration bit = 0); otherwise, they are disabled and these bits read as '0'.

PIC18F85J90 FAMILY

5.3.5 STATUS REGISTER

The STATUS register, shown in Register 5-2, contains the arithmetic status of the ALU. The STATUS register can be the operand for any instruction, as with any other register. If the STATUS register is the destination for an instruction that affects the Z, DC, C, OV or N bits, then the write to these five bits is disabled.

These bits are set or cleared according to the device logic. Therefore, the result of an instruction with the STATUS register as destination may be different than intended. For example, `CLRF STATUS` will set the Z bit but leave the other bits unchanged. The STATUS

register then reads back as '000u u1uu'. It is recommended, therefore, that only `BCF`, `BSF`, `SWAPF`, `MOVFF` and `MOVWF` instructions are used to alter the STATUS register because these instructions do not affect the Z, C, DC, OV or N bits in the STATUS register.

For other instructions not affecting any Status bits, see the instruction set summaries in Table 23-2 and Table 23-3.

Note: The C and DC bits operate as a borrow and digit borrow bit respectively, in subtraction.

REGISTER 5-2: STATUS REGISTER

U-0	U-0	U-0	R/W-x	R/W-x	R/W-x	R/W-x	R/W-x
—	—	—	N	OV	Z	DC ⁽¹⁾	C ⁽²⁾
bit 7							bit 0

Legend:

R = Readable bit	W = Writable bit	U = Unimplemented bit, read as '0'
-n = Value at POR	'1' = Bit is set	'0' = Bit is cleared
		x = Bit is unknown

bit 7-5 **Unimplemented:** Read as '0'

bit 4 **N:** Negative bit

This bit is used for signed arithmetic (2's complement). It indicates whether the result was negative (ALU MSB = 1).

1 = Result was negative
0 = Result was positive

bit 3 **OV:** Overflow bit

This bit is used for signed arithmetic (2's complement). It indicates an overflow of the 7-bit magnitude which causes the sign bit (bit 7) to change state.

1 = Overflow occurred for signed arithmetic (in this arithmetic operation)
0 = No overflow occurred

bit 2 **Z:** Zero bit

1 = The result of an arithmetic or logic operation is zero
0 = The result of an arithmetic or logic operation is not zero

bit 1 **DC:** Digit Carry/Borrow bit⁽¹⁾

For `ADDWF`, `ADDLW`, `SUBLW` and `SUBWF` instructions:

1 = A carry-out from the 4th low-order bit of the result occurred
0 = No carry-out from the 4th low-order bit of the result

bit 0 **C:** Carry/Borrow bit⁽²⁾

For `ADDWF`, `ADDLW`, `SUBLW` and `SUBWF` instructions:

1 = A carry-out from the Most Significant bit of the result occurred
0 = No carry-out from the Most Significant bit of the result occurred

Note 1: For borrow, the polarity is reversed. A subtraction is executed by adding the 2's complement of the second operand. For rotate (`RRF`, `RLF`) instructions, this bit is loaded with either bit 4 or bit 3 of the source register.

2: For borrow, the polarity is reversed. A subtraction is executed by adding the 2's complement of the second operand. For rotate (`RRF`, `RLF`) instructions, this bit is loaded with either the high or low-order bit of the source register.

PIC18F85J90 FAMILY

5.4 Data Addressing Modes

Note: The execution of some instructions in the core PIC18 instruction set are changed when the PIC18 extended instruction set is enabled. See **Section 5.6 “Data Memory and the Extended Instruction Set”** for more information.

While the program memory can be addressed in only one way – through the program counter – information in the data memory space can be addressed in several ways. For most instructions, the addressing mode is fixed. Other instructions may use up to three modes, depending on which operands are used and whether or not the extended instruction set is enabled.

The addressing modes are:

- Inherent
- Literal
- Direct
- Indirect

An additional addressing mode, Indexed Literal Offset, is available when the extended instruction set is enabled (XINST Configuration bit = 1). Its operation is discussed in greater detail in **Section 5.6.1 “Indexed Addressing with Literal Offset”**.

5.4.1 INHERENT AND LITERAL ADDRESSING

Many PIC18 control instructions do not need any argument at all; they either perform an operation that globally affects the device, or they operate implicitly on one register. This addressing mode is known as Inherent Addressing. Examples include `SLEEP`, `RESET` and `DAW`.

Other instructions work in a similar way, but require an additional explicit argument in the opcode. This is known as Literal Addressing mode, because they require some literal value as an argument. Examples include `ADDLW` and `MOVLW`, which respectively, add or move a literal value to the W register. Other examples include `CALL` and `GOTO`, which include a 20-bit program memory address.

5.4.2 DIRECT ADDRESSING

Direct Addressing specifies all or part of the source and/or destination address of the operation within the opcode itself. The options are specified by the arguments accompanying the instruction.

In the core PIC18 instruction set, bit-oriented and byte-oriented instructions use some version of Direct Addressing by default. All of these instructions include some 8-bit literal address as their Least Significant Byte. This address specifies either a register address in one of the banks of data RAM (**Section 5.3.3 “General Purpose Register File”**), or a location in the Access Bank (**Section 5.3.2 “Access Bank”**) as the data source for the instruction.

The Access RAM bit ‘a’ determines how the address is interpreted. When ‘a’ is ‘1’, the contents of the BSR (**Section 5.3.1 “Bank Select Register”**) are used with the address to determine the complete 12-bit address of the register. When ‘a’ is ‘0’, the address is interpreted as being a register in the Access Bank. Addressing that uses the Access RAM is sometimes also known as Direct Forced Addressing mode.

A few instructions, such as `MOVFF`, include the entire 12-bit address (either source or destination) in their opcodes. In these cases, the BSR is ignored entirely.

The destination of the operation’s results is determined by the destination bit ‘d’. When ‘d’ is ‘1’, the results are stored back in the source register, overwriting its original contents. When ‘d’ is ‘0’, the results are stored in the W register. Instructions without the ‘d’ argument have a destination that is implicit in the instruction; their destination is either the target register being operated on or the W register.

5.4.3 INDIRECT ADDRESSING

Indirect Addressing allows the user to access a location in data memory without giving a fixed address in the instruction. This is done by using File Select Registers (FSRs) as pointers to the locations to be read or written to. Since the FSRs are themselves located in RAM as Special Function Registers, they can also be directly manipulated under program control. This makes FSRs very useful in implementing data structures such as tables and arrays in data memory.

The registers for Indirect Addressing are also implemented with Indirect File Operands (INDFs) that permit automatic manipulation of the pointer value with auto-incrementing, auto-decrementing or offsetting with another value. This allows for efficient code using loops, such as the example of clearing an entire RAM bank in Example 5-5. It also enables users to perform Indexed Addressing and other Stack Pointer operations for program memory in data memory.

EXAMPLE 5-5: HOW TO CLEAR RAM (BANK 1) USING INDIRECT ADDRESSING

```
        LFSR   FSR0, 100h ;
NEXT    CLRF  POSTINC0   ; Clear INDF
                                ; register then
                                ; inc pointer
        BTFSS  FSR0H, 1   ; All done with
                                ; Bank1?
        BRA    NEXT      ; NO, clear next
CONTINUE                                ; YES, continue
```

5.4.3.1 FSR Registers and the INDF Operand

At the core of Indirect Addressing are three sets of registers: FSR0, FSR1 and FSR2. Each represents a pair of 8-bit registers, FSRnH and FSRnL. The four upper bits of the FSRnH register are not used, so each FSR pair holds a 12-bit value. This represents a value that can address the entire range of the data memory in a linear fashion. The FSR register pairs, then, serve as pointers to data memory locations.

Indirect Addressing is accomplished with a set of Indirect File Operands, INDF0 through INDF2. These can be thought of as “virtual” registers: they are mapped in

the SFR space but are not physically implemented. Reading or writing to a particular INDF register actually accesses its corresponding FSR register pair. A read from INDF1, for example, reads the data at the address indicated by FSR1H:FSR1L. Instructions that use the INDF registers as operands actually use the contents of their corresponding FSR as a pointer to the instruction’s target. The INDF operand is just a convenient way of using the pointer.

Because Indirect Addressing uses a full 12-bit address, data RAM banking is not necessary. Thus, the current contents of the BSR and the Access RAM bit have no effect on determining the target address.

FIGURE 5-9: INDIRECT ADDRESSING

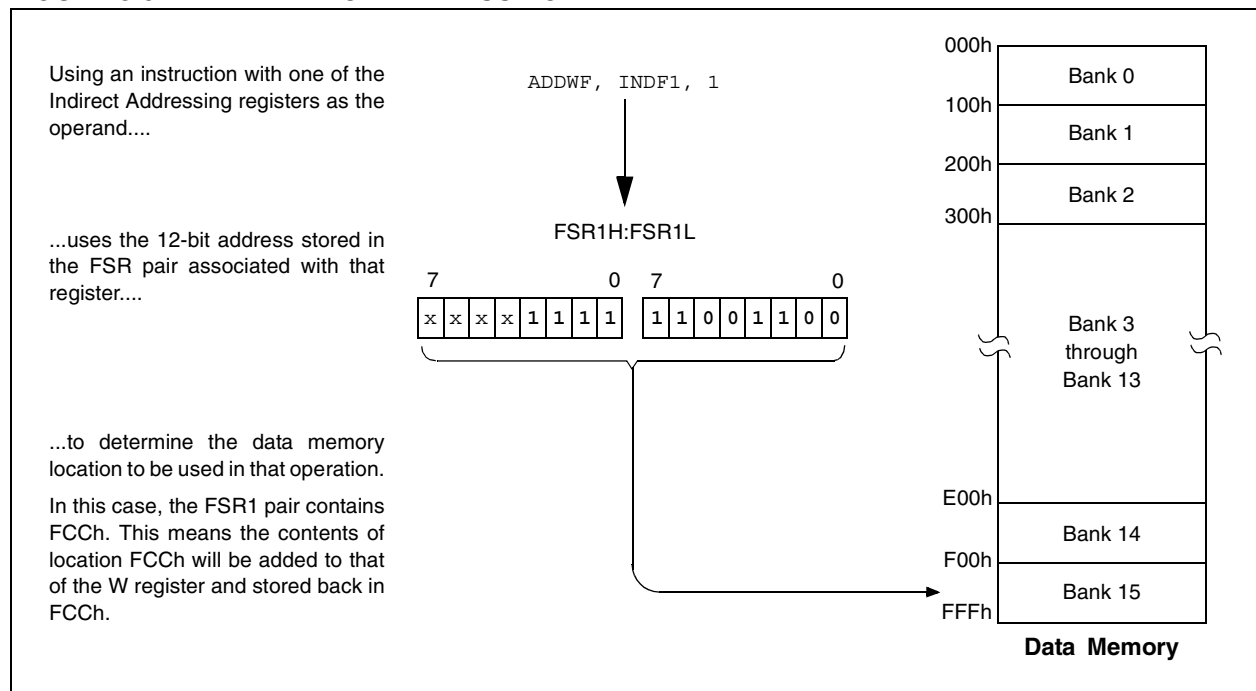

PIC18F85J90 FAMILY

5.4.3.2 FSR Registers and POSTINC, POSTDEC, PREINC and PLUSW

In addition to the INDF operand, each FSR register pair also has four additional indirect operands. Like INDF, these are “virtual” registers that cannot be indirectly read or written to. Accessing these registers actually accesses the associated FSR register pair, but also performs a specific action on its stored value. They are:

- **POSTDEC**: accesses the FSR value, then automatically decrements it by ‘1’ afterwards
- **POSTINC**: accesses the FSR value, then automatically increments it by ‘1’ afterwards
- **PREINC**: increments the FSR value by ‘1’, then uses it in the operation
- **PLUSW**: adds the signed value of the W register (range of -127 to 128) to that of the FSR and uses the new value in the operation

In this context, accessing an INDF register uses the value in the FSR registers without changing them. Similarly, accessing a PLUSW register gives the FSR value offset by the value in the W register; neither value is actually changed in the operation. Accessing the other virtual registers changes the value of the FSR registers.

Operations on the FSRs with POSTDEC, POSTINC and PREINC affect the entire register pair; that is, roll-overs of the FSRnL register from FFh to 00h carry over to the FSRnH register. On the other hand, results of these operations do not change the value of any flags in the STATUS register (e.g., Z, N, OV, etc.).

The PLUSW register can be used to implement a form of Indexed Addressing in the data memory space. By manipulating the value in the W register, users can reach addresses that are fixed offsets from pointer addresses. In some applications, this can be used to implement some powerful program control structure, such as software stacks, inside of data memory.

5.4.3.3 Operations by FSRs on FSRs

Indirect Addressing operations that target other FSRs or virtual registers represent special cases. For example, using an FSR to point to one of the virtual registers will not result in successful operations. As a specific case, assume that FSR0H:FSR0L contains FE7h, the address of INDF1. Attempts to read the value of the INDF1, using INDF0 as an operand, will return 00h. Attempts to write to INDF1, using INDF0 as the operand, will result in a NOP.

On the other hand, using the virtual registers to write to an FSR pair may not occur as planned. In these cases, the value will be written to the FSR pair but without any incrementing or decrementing. Thus, writing to INDF2 or POSTDEC2 will write the same value to the FSR2H:FSR2L.

Since the FSRs are physical registers mapped in the SFR space, they can be manipulated through all direct operations. Users should proceed cautiously when working on these registers, particularly if their code uses Indirect Addressing.

Similarly, operations by Indirect Addressing are generally permitted on all other SFRs. Users should exercise the appropriate caution that they do not inadvertently change settings that might affect the operation of the device.

5.5 Program Memory and the Extended Instruction Set

The operation of program memory is unaffected by the use of the extended instruction set.

Enabling the extended instruction set adds five additional two-word commands to the existing PIC18 instruction set: ADDFSR, CALLW, MOVSF, MOVSS and SUBFSR. These instructions are executed as described in **Section 5.2.4 “Two-Word Instructions”**.

5.6 Data Memory and the Extended Instruction Set

Enabling the PIC18 extended instruction set (XINST Configuration bit = 1) significantly changes certain aspects of data memory and its addressing. Specifically, the use of the Access Bank for many of the core PIC18 instructions is different; this is due to the introduction of a new addressing mode for the data memory space. This mode also alters the behavior of Indirect Addressing using FSR2 and its associated operands.

What does not change is just as important. The size of the data memory space is unchanged, as well as its linear addressing. The SFR map remains the same. Core PIC18 instructions can still operate in both Direct and Indirect Addressing mode; inherent and literal instructions do not change at all. Indirect Addressing with FSR0 and FSR1 also remains unchanged.

5.6.1 INDEXED ADDRESSING WITH LITERAL OFFSET

Enabling the PIC18 extended instruction set changes the behavior of Indirect Addressing using the FSR2 register pair and its associated file operands. Under the proper conditions, instructions that use the Access Bank – that is, most bit-oriented and byte-oriented instructions – can invoke a form of Indexed Addressing using an offset specified in the instruction. This special addressing mode is known as Indexed Addressing with Literal Offset, or Indexed Literal Offset mode.

When using the extended instruction set, this addressing mode requires the following:

- The use of the Access Bank is forced ('a' = 0); and
- The file address argument is less than or equal to 5Fh.

Under these conditions, the file address of the instruction is not interpreted as the lower byte of an address (used with the BSR in Direct Addressing) or as an 8-bit address in the Access Bank. Instead, the value is interpreted as an offset value to an Address Pointer specified by FSR2. The offset and the contents of FSR2 are added to obtain the target address of the operation.

5.6.2 INSTRUCTIONS AFFECTED BY INDEXED LITERAL OFFSET MODE

Any of the core PIC18 instructions that can use Direct Addressing are potentially affected by the Indexed Literal Offset Addressing mode. This includes all byte-oriented and bit-oriented instructions, or almost one-half of the standard PIC18 instruction set. Instructions that only use Inherent or Literal Addressing modes are unaffected.

Additionally, byte-oriented and bit-oriented instructions are not affected if they use the Access Bank (Access RAM bit is '1') or include a file address of 60h or above. Instructions meeting these criteria will continue to execute as before. A comparison of the different possible addressing modes when the extended instruction set is enabled is shown in Figure 5-10.

Those who desire to use byte-oriented or bit-oriented instructions in the Indexed Literal Offset mode should note the changes to assembler syntax for this mode. This is described in more detail in **Section 23.2.1 “Extended Instruction Syntax”**.

PIC18F85J90 FAMILY

FIGURE 5-10: COMPARING ADDRESSING OPTIONS FOR BIT-ORIENTED AND BYTE-ORIENTED INSTRUCTIONS (EXTENDED INSTRUCTION SET ENABLED)

EXAMPLE INSTRUCTION: ADDWF, f, d, a (Opcode: 0010 01da ffff ffff)

When a = 0 and f ≥ 60h:

The instruction executes in Direct Forced mode. 'f' is interpreted as a location in the Access RAM between 060h and FFFh. This is the same as locations F60h to FFFh (Bank 15) of data memory.

Locations below 060h are not available in this addressing mode.

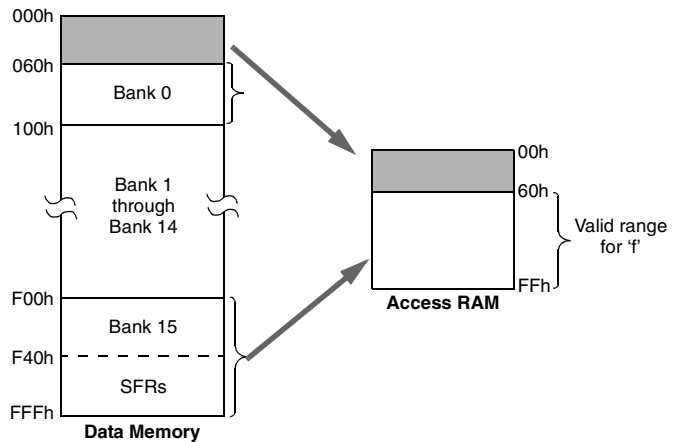

When a = 0 and f ≤ 5Fh:

The instruction executes in Indexed Literal Offset mode. 'f' is interpreted as an offset to the address value in FSR2. The two are added together to obtain the address of the target register for the instruction. The address can be anywhere in the data memory space.

Note that in this mode, the correct syntax is now:

ADDWF [k], d
where 'k' is the same as 'f'.

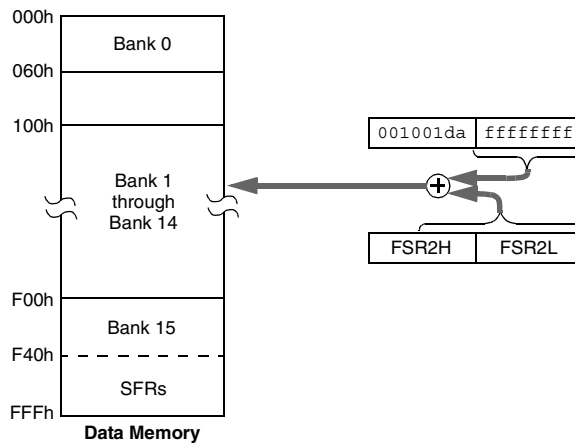

When a = 1 (all values of f):

The instruction executes in Direct mode (also known as Direct Long mode). 'f' is interpreted as a location in one of the 16 banks of the data memory space. The bank is designated by the Bank Select Register (BSR). The address can be in any implemented bank in the data memory space.

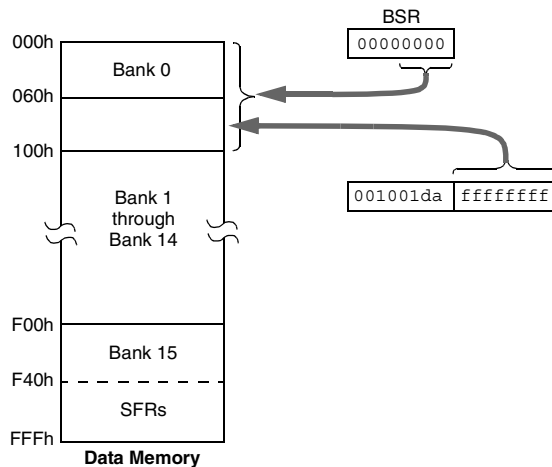

PIC18F85J90 FAMILY

5.6.3 MAPPING THE ACCESS BANK IN INDEXED LITERAL OFFSET MODE

The use of Indexed Literal Offset Addressing mode effectively changes how the lower part of Access RAM (00h to 5Fh) is mapped. Rather than containing just the contents of the bottom part of Bank 0, this mode maps the contents from Bank 0 and a user-defined “window” that can be located anywhere in the data memory space. The value of FSR2 establishes the lower boundary of the addresses mapped into the window, while the upper boundary is defined by FSR2 plus 95 (5Fh). Addresses in the Access RAM above 5Fh are mapped as previously described (see **Section 5.3.2 “Access Bank”**). An example of Access Bank remapping in this addressing mode is shown in Figure 5-11.

Remapping of the Access Bank applies *only* to operations using the Indexed Literal Offset mode. Operations that use the BSR (Access RAM bit is ‘1’) will continue to use Direct Addressing as before. Any Indirect or Indexed Addressing operation that explicitly uses any of the indirect file operands (including FSR2) will continue to operate as standard Indirect Addressing. Any instruction that uses the Access Bank, but includes a register address of greater than 05Fh, will use Direct Addressing and the normal Access Bank map.

5.6.4 BSR IN INDEXED LITERAL OFFSET MODE

Although the Access Bank is remapped when the extended instruction set is enabled, the operation of the BSR remains unchanged. Direct Addressing, using the BSR to select the data memory bank, operates in the same manner as previously described.

FIGURE 5-11: REMAPPING THE ACCESS BANK WITH INDEXED LITERAL OFFSET ADDRESSING

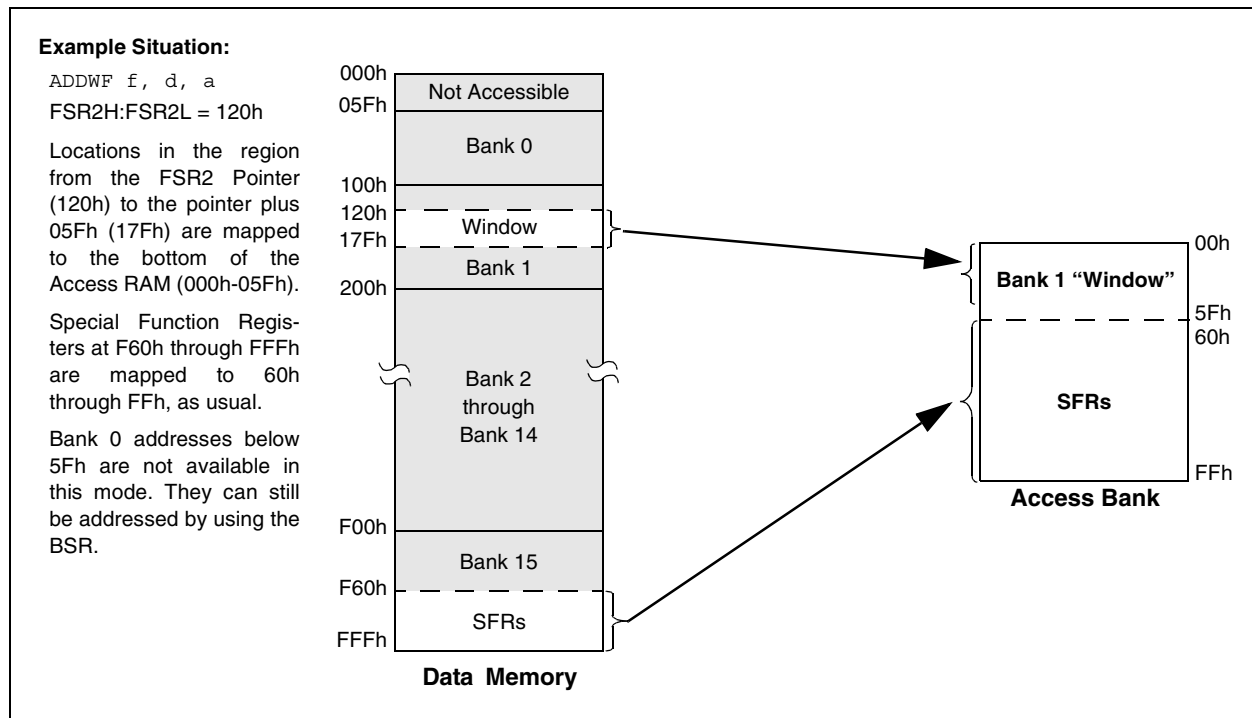

PIC18F85J90 FAMILY

NOTES:

6.0 FLASH PROGRAM MEMORY

The Flash program memory is readable, writable and erasable during normal operation over the entire VDD range.

A read from program memory is executed on one byte at a time. A write to program memory is executed on blocks of 64 bytes at a time. Program memory is erased in blocks of 1024 bytes at a time. A Bulk Erase operation may not be issued from user code.

Writing or erasing program memory will cease instruction fetches until the operation is complete. The program memory cannot be accessed during the write or erase, therefore, code cannot execute. An internal programming timer terminates program memory writes and erases.

A value written to program memory does not need to be a valid instruction. Executing a program memory location that forms an invalid instruction results in a NOP.

6.1 Table Reads and Table Writes

In order to read and write program memory, there are two operations that allow the processor to move bytes between the program memory space and the data RAM:

- Table Read (TBLRD)
- Table Write (TBLWT)

The program memory space is 16 bits wide, while the data RAM space is 8 bits wide. Table reads and table writes move data between these two memory spaces through an 8-bit register (TABLAT).

Table read operations retrieve data from program memory and place it into the data RAM space. Figure 6-1 shows the operation of a table read with program memory and data RAM.

Table write operations store data from the data memory space into holding registers in program memory. The procedure to write the contents of the holding registers into program memory is detailed in **Section 6.5 “Writing to Flash Program Memory”**. Figure 6-2 shows the operation of a table write with program memory and data RAM.

Table operations work with byte entities. A table block containing data, rather than program instructions, is not required to be word-aligned. Therefore, a table block can start and end at any byte address. If a table write is being used to write executable code into program memory, program instructions will need to be word-aligned.

FIGURE 6-1: TABLE READ OPERATION

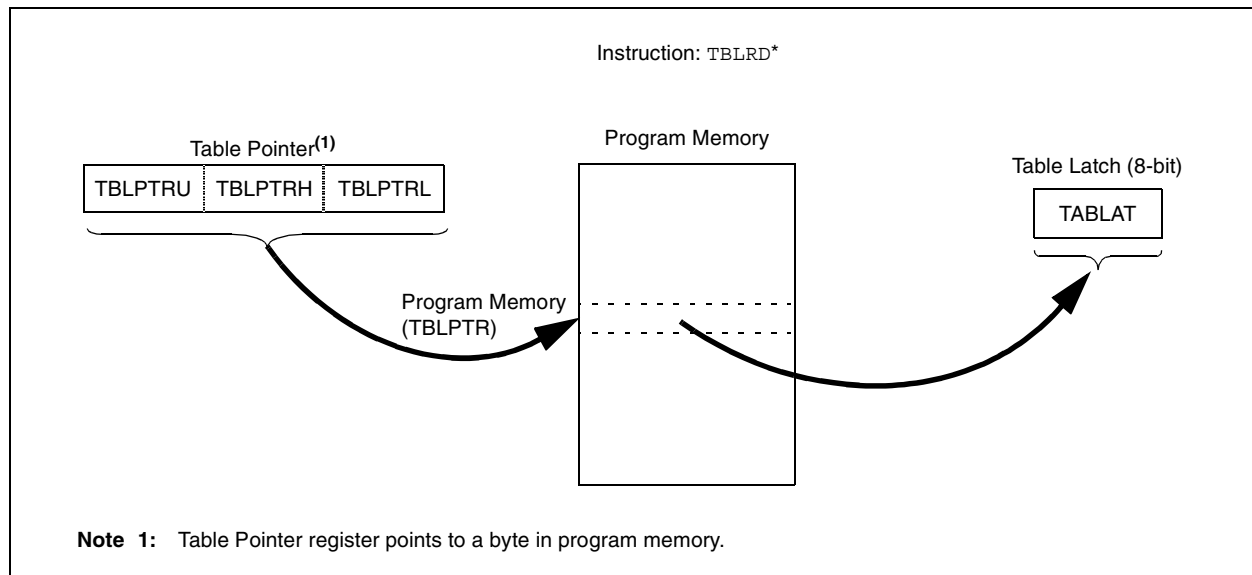

PIC18F85J90 FAMILY

FIGURE 6-2: TABLE WRITE OPERATION

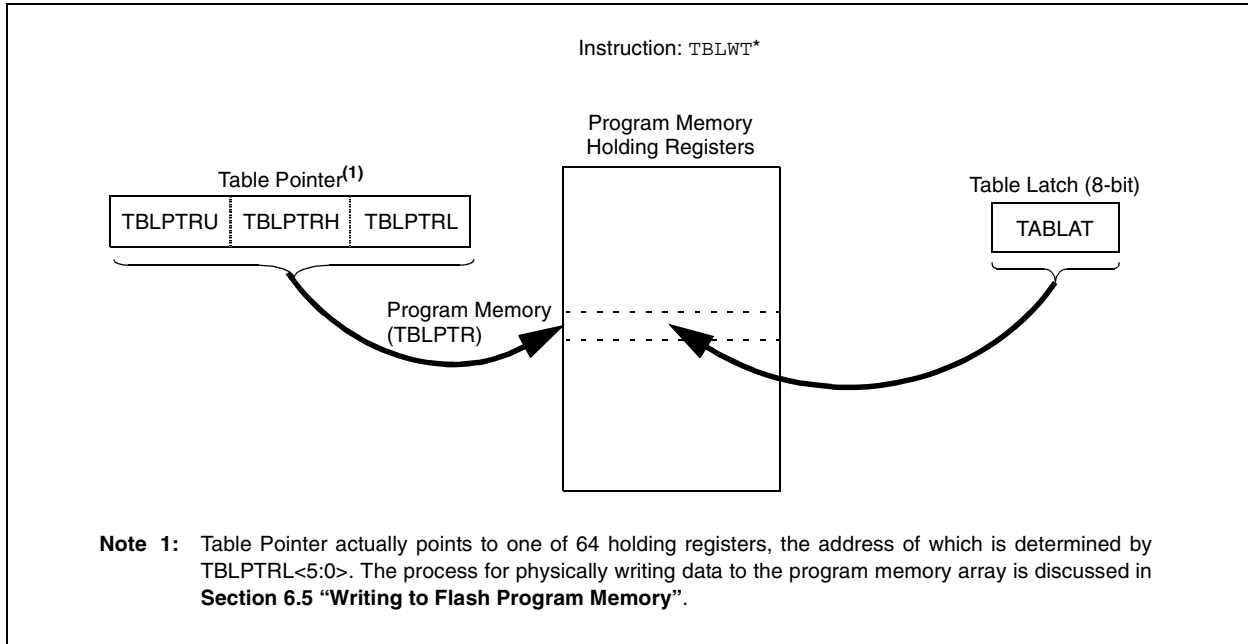

6.2 Control Registers

Several control registers are used in conjunction with the TBLRD and TBLWT instructions. These include the:

- EECON1 register
- EECON2 register
- TABLAT register
- TBLPTR registers

6.2.1 EECON1 AND EECON2 REGISTERS

The EECON1 register (Register 6-1) is the control register for memory accesses. The EECON2 register is not a physical register; it is used exclusively in the memory write and erase sequences. Reading EECON2 will read all '0's.

The FREE bit, when set, will allow a program memory erase operation. When FREE is set, the erase operation is initiated on the next WR command. When FREE is clear, only writes are enabled.

The WREN bit, when set, will allow a write operation. On power-up, the WREN bit is clear. The WRERR bit is set in hardware when the WR bit is set and cleared when the internal programming timer expires and the write operation is complete.

Note: During normal operation, the WRERR is read as '1'. This can indicate that a write operation was prematurely terminated by a Reset, or a write operation was attempted improperly.

The WR control bit initiates write operations. The bit cannot be cleared, only set, in software. It is cleared in hardware at the completion of the write operation.

PIC18F85J90 FAMILY

REGISTER 6-1: EECON1: EEPROM CONTROL REGISTER 1

U-0	U-0	U-0	R/W-0	R/W-x	R/W-0	R/S-0	U-0
—	—	—	FREE	WRERR	WREN	WR	—
bit 7							bit 0

Legend:	U = Unimplemented bit, read as '0'
R = Readable bit	W = Writable bit
-n = Value at POR	'1' = Bit is set
	S = Set only bit (cannot be cleared in software)
	'0' = Bit is cleared
	x = Bit is unknown

- bit 7-5 **Unimplemented:** Read as '0'
- bit 4 **FREE:** Flash Row Erase Enable bit
 1 = Erase the program memory row addressed by TBLPTR on the next WR command (cleared by completion of erase operation)
 0 = Perform write only
- bit 3 **WRERR:** Flash Program Error Flag bit
 1 = A write operation is prematurely terminated (any Reset during self-timed programming in normal operation, or an improper write attempt)
 0 = The write operation completed
- bit 2 **WREN:** Flash Program Write Enable bit
 1 = Allows write cycles to Flash program memory
 0 = Inhibits write cycles to Flash program memory
- bit 1 **WR:** Write Control bit
 1 = Initiates a program memory erase cycle or write cycle
 (The operation is self-timed and the bit is cleared by hardware once write is complete.
 The WR bit can only be set (not cleared) in software.)
 0 = Write cycle is complete
- bit 0 **Unimplemented:** Read as '0'

PIC18F85J90 FAMILY

6.2.2 TABLE LATCH REGISTER (TABLAT)

The Table Latch (TABLAT) is an 8-bit register mapped into the SFR space. The Table Latch register is used to hold 8-bit data during data transfers between program memory and data RAM.

6.2.3 TABLE POINTER REGISTER (TBLPTR)

The Table Pointer (TBLPTR) register addresses a byte within the program memory. The TBLPTR is comprised of three SFR registers: Table Pointer Upper Byte, Table Pointer High Byte and Table Pointer Low Byte (TBLPTRU:TBLPTRH:TBLPTRL). These three registers join to form a 22-bit wide pointer. The low-order 21 bits allow the device to address up to 2 Mbytes of program memory space. The 22nd bit allows access to the device ID, the user ID and the Configuration bits.

The Table Pointer register, TBLPTR, is used by the TBLRD and TBLWT instructions. These instructions can update the TBLPTR in one of four ways based on the table operation. These operations are shown in Table 6-1. These operations on the TBLPTR only affect the low-order 21 bits.

6.2.4 TABLE POINTER BOUNDARIES

TBLPTR is used in reads, writes and erases of the Flash program memory.

When a TBLRD is executed, all 22 bits of the TBLPTR determine which byte is read from program memory into TABLAT.

When a TBLWT is executed, the seven LSbs of the Table Pointer register (TBLPTR<6:0>) determine which of the 64 program memory holding registers is written to. When the timed write to program memory begins (via the WR bit), the 12 MSBs of the TBLPTR (TBLPTR<21:10>) determine which program memory block of 1024 bytes is written to. For more detail, see **Section 6.5 “Writing to Flash Program Memory”**.

When an erase of program memory is executed, the 12 MSBs of the Table Pointer register point to the 1024-byte block that will be erased. The Least Significant bits are ignored.

Figure 6-3 describes the relevant boundaries of the TBLPTR based on Flash program memory operations.

TABLE 6-1: TABLE POINTER OPERATIONS WITH TBLRD AND TBLWT INSTRUCTIONS

Example	Operation on Table Pointer
TBLRD* TBLWT*	TBLPTR is not modified
TBLRD*+ TBLWT*+	TBLPTR is incremented after the read/write
TBLRD*- TBLWT*-	TBLPTR is decremented after the read/write
TBLRD+* TBLWT+*	TBLPTR is incremented before the read/write

FIGURE 6-3: TABLE POINTER BOUNDARIES BASED ON OPERATION

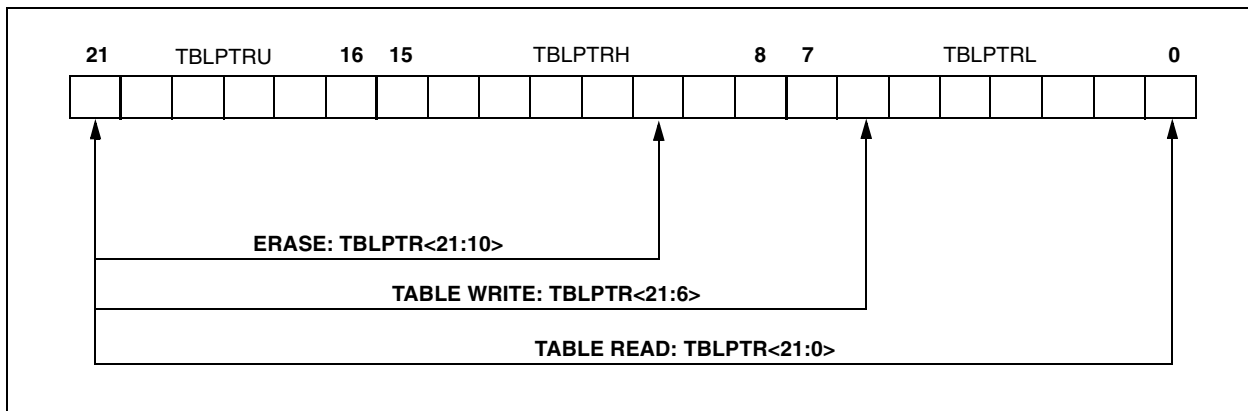

6.3 Reading the Flash Program Memory

The `TBLRD` instruction is used to retrieve data from program memory and places it into data RAM. Table reads from program memory are performed one byte at a time.

`TBLPTR` points to a byte address in program space. Executing `TBLRD` places the byte pointed to into `TABLAT`. In addition, `TBLPTR` can be modified automatically for the next table read operation.

The internal program memory is typically organized by words. The Least Significant bit of the address selects between the high and low bytes of the word. Figure 6-4 shows the interface between the internal program memory and the `TABLAT`.

FIGURE 6-4: READS FROM FLASH PROGRAM MEMORY

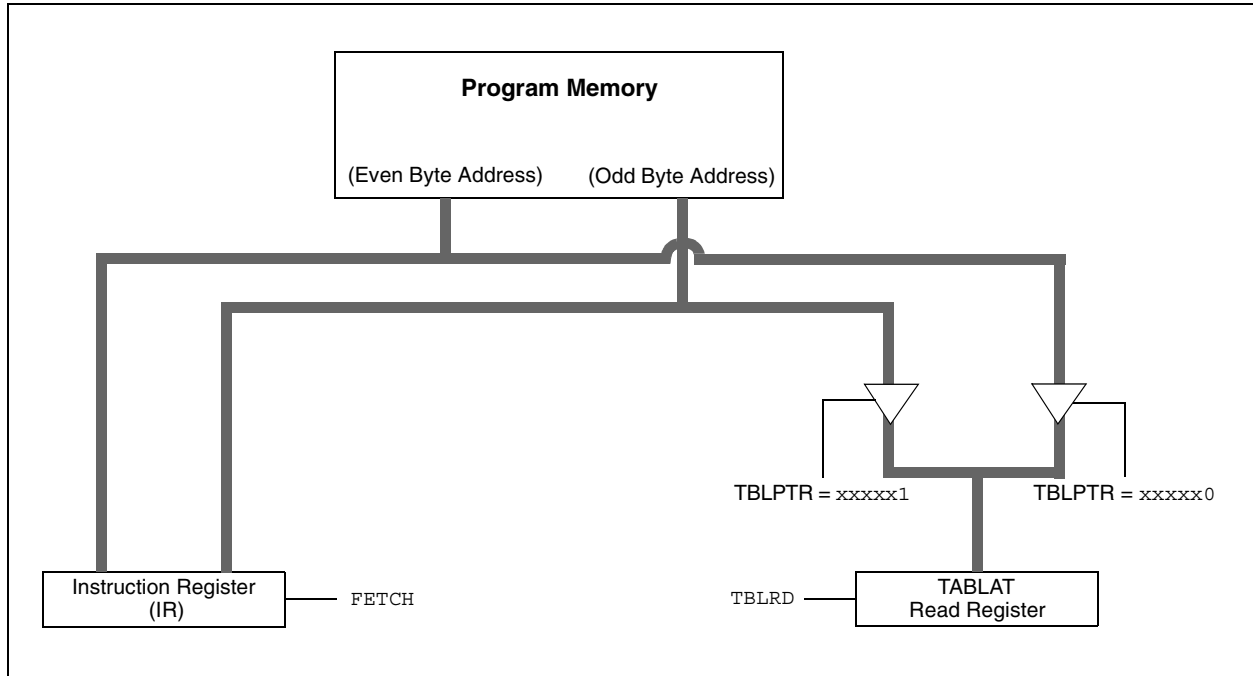

EXAMPLE 6-1: READING A FLASH PROGRAM MEMORY WORD

```

        MOVLW    CODE_ADDR_UPPER           ; Load TBLPTR with the base
        MOVWF   TBLPTRU                    ; address of the word
        MOVLW    CODE_ADDR_HIGH
        MOVWF   TBLPTRH
        MOVLW    CODE_ADDR_LOW
        MOVWF   TBLPTRL
READ_WORD
        TBLRD*+                               ; read into TABLAT and increment
        MOVF    TABLAT, W                   ; get data
        MOVWF   WORD_EVEN
        TBLRD*+                               ; read into TABLAT and increment
        MOVF    TABLAT, W                   ; get data
        MOVWF   WORD_ODD
    
```

PIC18F85J90 FAMILY

6.4 Erasing Flash Program Memory

The minimum erase block is 512 words or 1024 bytes. Only through the use of an external programmer, or through ICSP control, can larger blocks of program memory be Bulk Erased. Word erase in the Flash array is not supported.

When initiating an erase sequence from the microcontroller itself, a block of 1024 bytes of program memory is erased. The Most Significant 12 bits of the TBLPTR<21:10> point to the block being erased; TBLPTR<9:0> are ignored.

The EECON1 register commands the erase operation. The WREN bit must be set to enable write operations. The FREE bit is set to select an erase operation. For protection, the write initiate sequence for EECON2 must be used.

A long write is necessary for erasing the internal Flash. Instruction execution is halted while in a long write cycle. The long write will be terminated by the internal programming timer.

6.4.1 FLASH PROGRAM MEMORY ERASE SEQUENCE

The sequence of events for erasing a block of internal program memory location is:

1. Load Table Pointer register with address of row being erased.
2. Set the WREN and FREE bits (EECON1<2,4>) to enable the erase operation.
3. Disable interrupts.
4. Write 55h to EECON2.
5. Write 0AAh to EECON2.
6. Set the WR bit. This will begin the Row Erase cycle.
7. The CPU will stall for duration of the erase for T_{IW} (see parameter D133A).
8. Re-enable interrupts.

EXAMPLE 6-2: ERASING A FLASH PROGRAM MEMORY ROW

	MOVLW	CODE_ADDR_UPPER		; load TBLPTR with the base
	MOVWF	TBLPTRU		; address of the memory block
	MOVLW	CODE_ADDR_HIGH		
	MOVWF	TBLPTRH		
	MOVLW	CODE_ADDR_LOW		
	MOVWF	TBLPTRL		
ERASE_ROW				
	BSF	EECON1, WREN		; enable write to memory
	BSF	EECON1, FREE		; enable Row Erase operation
	BCF	INTCON, GIE		; disable interrupts
Required Sequence	MOVLW	55h		
	MOVWF	EECON2		; write 55h
	MOVLW	0AAh		
	MOVWF	EECON2		; write 0AAh
	BSF	EECON1, WR		; start erase (CPU stall)
	BSF	INTCON, GIE		; re-enable interrupts

6.5 Writing to Flash Program Memory

The minimum programming block is 32 words or 64 bytes. Word or byte programming is not supported.

Table writes are used internally to load the holding registers needed to program the Flash memory. There are 64 holding registers used by the table writes for programming.

Since the Table Latch (TABLAT) is only a single byte, the TBLWT instruction may need to be executed 64 times for each programming operation. All of the table write operations will essentially be short writes because only the holding registers are written. At the end of updating the 64 holding registers, the EECON1 register must be written to in order to start the programming operation with a long write.

The long write is necessary for programming the internal Flash. Instruction execution is halted while in a long write cycle. The long write will be terminated by the internal programming timer.

The on-chip timer controls the write time. The write/erase voltages are generated by an on-chip charge pump, rated to operate over the voltage range of the device.

Note 1: Unlike previous PIC® devices, members of the PIC18F85J90 family do not reset the holding registers after a write occurs. The holding registers must be cleared or overwritten before a programming sequence.

2: To maintain the endurance of the program memory cells, each Flash byte should not be programmed more than one time between erase operations. Before attempting to modify the contents of the target cell a second time, a Row Erase of the target row, or a Bulk Erase of the entire memory, must be performed.

FIGURE 6-5: TABLE WRITES TO FLASH PROGRAM MEMORY

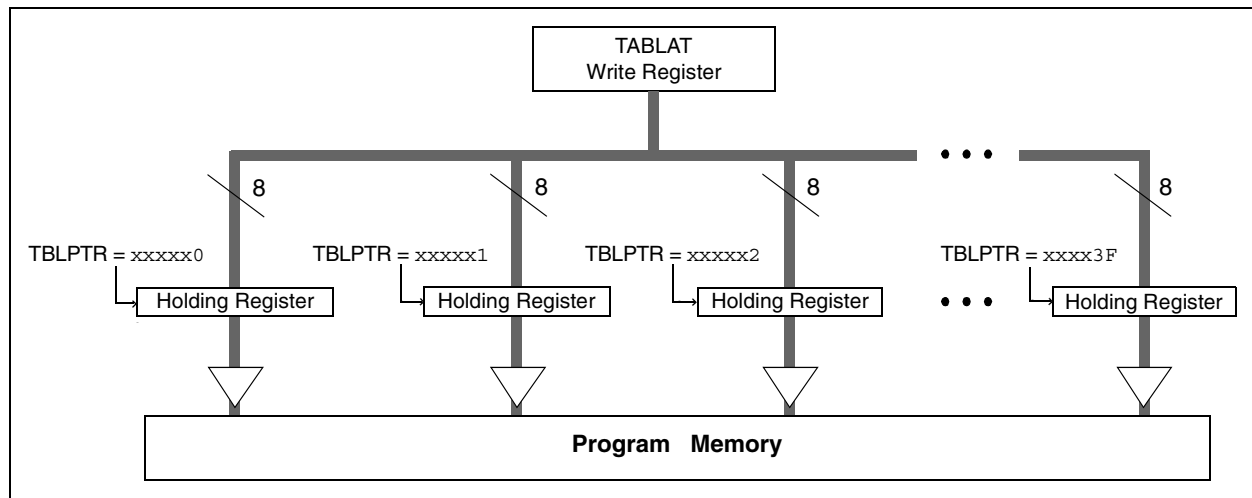

6.5.1 FLASH PROGRAM MEMORY WRITE SEQUENCE

The sequence of events for programming an internal program memory location should be:

1. Read 1024 bytes into RAM.
2. Update data values in RAM as necessary.
3. Load Table Pointer register with address being erased.
4. Execute the Row Erase procedure.
5. Load Table Pointer register with address of first byte being written, minus 1.
6. Write the 64 bytes into the holding registers with auto-increment.
7. Set the WREN bit (EECON1<2>) to enable byte writes.

8. Disable interrupts.
9. Write 55h to EECON2.
10. Write 0AAh to EECON2.
11. Set the WR bit. This will begin the write cycle.
12. The CPU will stall for duration of the write for T_{iw} (see parameter D133A).
13. Re-enable interrupts.
14. Repeat steps 6 through 13 until all 1024 bytes are written to program memory.
15. Verify the memory (table read).

An example of the required code is shown in Example 6-3 on the following page.

Note: Before setting the WR bit, the Table Pointer address needs to be within the intended address range of the 64 bytes in the holding register.

PIC18F85J90 FAMILY

EXAMPLE 6-3: WRITING TO FLASH PROGRAM MEMORY

```
MOV LW CODE_ADDR_UPPER      ; Load TBLPTR with the base address
MOV WF TBLPTRU              ; of the memory block, minus 1
MOV LW CODE_ADDR_HIGH
MOV WF TBLPTRH
MOV LW CODE_ADDR_LOW
MOV WF TBLPTRL

ERASE_BLOCK

BSF EECON1, WREN           ; enable write to memory
BSF EECON1, FREE          ; enable Row Erase operation
BCF INTCON, GIE           ; disable interrupts
MOV LW 55h
MOV WF EECON2              ; write 55h
MOV LW 0AAh
MOV WF EECON2              ; write 0AAh
BSF EECON1, WR            ; start erase (CPU stall)
BSF INTCON, GIE          ; re-enable interrupts
MOV LW D'16'
MOV WF WRITE_COUNTER      ; Need to write 16 blocks of 64 to write
                           ; one erase block of 1024

RESTART_BUFFER

MOV LW D'64'
MOV WF COUNTER
MOV LW BUFFER_ADDR_HIGH   ; point to buffer
MOV WF FSR0H
MOV LW BUFFER_ADDR_LOW
MOV WF FSR0L

FILL_BUFFER

...                        ; read the new data from I2C, SPI,
                           ; PSP, USART, etc.

WRITE_BUFFER

MOV LW D'64                ; number of bytes in holding register
MOV WF COUNTER

WRITE_BYTE_TO_HREGS

MOV FF POSTINC0, WREG      ; get low byte of buffer data
MOV WF TABLAT              ; present data to table latch
TBLWT*                     ; write data, perform a short write
                           ; to internal TBLWT holding register.
DECFSZ COUNTER             ; loop until buffers are full
BRA WRITE_BYTE_TO_HREGS

PROGRAM_MEMORY

BSF EECON1, WREN           ; enable write to memory
BCF INTCON, GIE           ; disable interrupts
MOV LW 55h
MOV WF EECON2              ; write 55h
MOV LW 0AAh
MOV WF EECON2              ; write 0AAh
BSF EECON1, WR            ; start program (CPU stall)
BSF INTCON, GIE          ; re-enable interrupts
BCF EECON1, WREN          ; disable write to memory

DECFSZ WRITE_COUNTER      ; done with one write cycle
BRA RESTART_BUFFER        ; if not done replacing the erase block
```

PIC18F85J90 FAMILY

6.5.2 WRITE VERIFY

Depending on the application, good programming practice may dictate that the value written to the memory should be verified against the original value. This should be used in applications where excessive writes can stress bits near the specification limit.

6.5.3 UNEXPECTED TERMINATION OF WRITE OPERATION

If a write is terminated by an unplanned event, such as loss of power or an unexpected Reset, the memory location just programmed should be verified and reprogrammed if needed. If the write operation is interrupted by a MCLR Reset or a WDT Time-out Reset during normal operation, the user can check the WRERR bit and rewrite the location(s) as needed.

6.6 Flash Program Operation During Code Protection

See **Section 22.6 “Program Verification and Code Protection”** for details on code protection of Flash program memory.

TABLE 6-2: REGISTERS ASSOCIATED WITH PROGRAM FLASH MEMORY

Name	Bit 7	Bit 6	Bit 5	Bit 4	Bit 3	Bit 2	Bit 1	Bit 0	Reset Values on page
TBLPTRU	—	—	bit 21	Program Memory Table Pointer Upper Byte (TBLPTR<20:16>)					51
TBPLTRH	Program Memory Table Pointer High Byte (TBLPTR<15:8>)								51
TBLPTRL	Program Memory Table Pointer Low Byte (TBLPTR<7:0>)								51
TABLAT	Program Memory Table Latch								51
INTCON	GIE/GIEH	PEIE/GIEL	TMR0IE	INT0IE	RBIE	TMR0IF	INT0IF	RBIF	51
EECON2	EEPROM Control Register 2 (not a physical register)								53
EECON1	—	—	—	FREE	WRERR	WREN	WR	—	53

Legend: — = unimplemented, read as ‘0’. Shaded cells are not used during program memory access.

PIC18F85J90 FAMILY

NOTES:

PIC18F85J90 FAMILY

7.0 8 x 8 HARDWARE MULTIPLIER

7.1 Introduction

All PIC18 devices include an 8 x 8 hardware multiplier as part of the ALU. The multiplier performs an unsigned operation and yields a 16-bit result that is stored in the Product register pair, PRODH:PRODL. The multiplier's operation does not affect any flags in the STATUS register.

Making multiplication a hardware operation allows it to be completed in a single instruction cycle. This has the advantages of higher computational throughput and reduced code size for multiplication algorithms and allows the PIC18 devices to be used in many applications previously reserved for digital signal processors. A comparison of various hardware and software multiply operations, along with the savings in memory and execution time, is shown in Table 7-1.

7.2 Operation

Example 7-1 shows the instruction sequence for an 8 x 8 unsigned multiplication. Only one instruction is required when one of the arguments is already loaded in the WREG register.

Example 7-2 shows the sequence to do an 8 x 8 signed multiplication. To account for the sign bits of the arguments, each argument's Most Significant bit (MSb) is tested and the appropriate subtractions are done.

EXAMPLE 7-1: 8 x 8 UNSIGNED MULTIPLY ROUTINE

```
MOVWF ARG1, W ;
MULWF ARG2 ; ARG1 * ARG2 ->
; PRODH:PRODL
```

EXAMPLE 7-2: 8 x 8 SIGNED MULTIPLY ROUTINE

```
MOVWF ARG1, W
MULWF ARG2 ; ARG1 * ARG2 ->
; PRODH:PRODL

BTFSC ARG2, SB ; Test Sign Bit
SUBWF PRODH, F ; PRODH = PRODH
; - ARG1

MOVWF ARG2, W
BTFSC ARG1, SB ; Test Sign Bit
SUBWF PRODH, F ; PRODH = PRODH
; - ARG2
```

TABLE 7-1: PERFORMANCE COMPARISON FOR VARIOUS MULTIPLY OPERATIONS

Routine	Multiply Method	Program Memory (Words)	Cycles (Max)	Time		
				@ 40 MHz	@ 10 MHz	@ 4 MHz
8 x 8 unsigned	Without hardware multiply	13	69	6.9 μ s	27.6 μ s	69 μ s
	Hardware multiply	1	1	100 ns	400 ns	1 μ s
8 x 8 signed	Without hardware multiply	33	91	9.1 μ s	36.4 μ s	91 μ s
	Hardware multiply	6	6	600 ns	2.4 μ s	6 μ s
16 x 16 unsigned	Without hardware multiply	21	242	24.2 μ s	96.8 μ s	242 μ s
	Hardware multiply	28	28	2.8 μ s	11.2 μ s	28 μ s
16 x 16 signed	Without hardware multiply	52	254	25.4 μ s	102.6 μ s	254 μ s
	Hardware multiply	35	40	4.0 μ s	16.0 μ s	40 μ s

PIC18F85J90 FAMILY

Example 7-3 shows the sequence to do a 16 x 16 unsigned multiplication. Equation 7-1 shows the algorithm that is used. The 32-bit result is stored in four registers (RES3:RES0).

EQUATION 7-1: 16 x 16 UNSIGNED MULTIPLICATION ALGORITHM

$$\begin{aligned} \text{RES3:RES0} &= \text{ARG1H:ARG1L} \cdot \text{ARG2H:ARG2L} \\ &= (\text{ARG1H} \cdot \text{ARG2H} \cdot 2^{16}) + \\ &\quad (\text{ARG1H} \cdot \text{ARG2L} \cdot 2^8) + \\ &\quad (\text{ARG1L} \cdot \text{ARG2H} \cdot 2^8) + \\ &\quad (\text{ARG1L} \cdot \text{ARG2L}) \end{aligned}$$

EXAMPLE 7-3: 16 x 16 UNSIGNED MULTIPLY ROUTINE

```

MOVF ARG1L, W
MULWF ARG2L          ; ARG1L * ARG2L ->
                      ; PRODH:PRODL

MOVFF PRODH, RES1   ;
MOVFF PRODL, RES0   ;
;

MOVF ARG1H, W
MULWF ARG2H          ; ARG1H * ARG2H ->
                      ; PRODH:PRODL

MOVFF PRODH, RES3   ;
MOVFF PRODL, RES2   ;
;

MOVF ARG1L, W
MULWF ARG2H          ; ARG1L * ARG2H ->
                      ; PRODH:PRODL

MOVF PRODL, W
ADDWF RES1, F        ; Add cross
MOVF PRODH, W        ; products
ADDWFC RES2, F       ;
CLRF WREG            ;
ADDWFC RES3, F       ;
;

MOVF ARG1H, W
MULWF ARG2L          ; ARG1H * ARG2L ->
                      ; PRODH:PRODL

MOVF PRODL, W
ADDWF RES1, F        ; Add cross
MOVF PRODH, W        ; products
ADDWFC RES2, F       ;
CLRF WREG            ;
ADDWFC RES3, F       ;

```

Example 7-4 shows the sequence to do a 16 x 16 signed multiply. Equation 7-2 shows the algorithm used. The 32-bit result is stored in four registers (RES3:RES0). To account for the sign bits of the arguments, the MSb for each argument pair is tested and the appropriate subtractions are done.

EQUATION 7-2: 16 x 16 SIGNED MULTIPLICATION ALGORITHM

$$\begin{aligned} \text{RES3:RES0} &= \text{ARG1H:ARG1L} \cdot \text{ARG2H:ARG2L} \\ &= (\text{ARG1H} \cdot \text{ARG2H} \cdot 2^{16}) + \\ &\quad (\text{ARG1H} \cdot \text{ARG2L} \cdot 2^8) + \\ &\quad (\text{ARG1L} \cdot \text{ARG2H} \cdot 2^8) + \\ &\quad (\text{ARG1L} \cdot \text{ARG2L}) + \\ &\quad (-1 \cdot \text{ARG2H} < 7 > \cdot \text{ARG1H:ARG1L} \cdot 2^{16}) + \\ &\quad (-1 \cdot \text{ARG1H} < 7 > \cdot \text{ARG2H:ARG2L} \cdot 2^{16}) \end{aligned}$$

EXAMPLE 7-4: 16 x 16 SIGNED MULTIPLY ROUTINE

```

MOVF ARG1L, W
MULWF ARG2L          ; ARG1L * ARG2L ->
                      ; PRODH:PRODL

MOVFF PRODH, RES1   ;
MOVFF PRODL, RES0   ;
;

MOVF ARG1H, W
MULWF ARG2H          ; ARG1H * ARG2H ->
                      ; PRODH:PRODL

MOVFF PRODH, RES3   ;
MOVFF PRODL, RES2   ;
;

MOVF ARG1L, W
MULWF ARG2H          ; ARG1L * ARG2H ->
                      ; PRODH:PRODL

MOVF PRODL, W
ADDWF RES1, F        ; Add cross
MOVF PRODH, W        ; products
ADDWFC RES2, F       ;
CLRF WREG            ;
ADDWFC RES3, F       ;
;

MOVF ARG1H, W
MULWF ARG2L          ; ARG1H * ARG2L ->
                      ; PRODH:PRODL

MOVF PRODL, W
ADDWF RES1, F        ; Add cross
MOVF PRODH, W        ; products
ADDWFC RES2, F       ;
CLRF WREG            ;
ADDWFC RES3, F       ;
;

BTFS ARG2H, 7        ; ARG2H:ARG2L neg?
BRA SIGN_ARG1        ; no, check ARG1
MOVF ARG1L, W
SUBWF RES2
MOVF ARG1H, W
SUBWFB RES3
;

SIGN_ARG1
BTFS ARG1H, 7        ; ARG1H:ARG1L neg?
BRA CONT_CODE        ; no, done
MOVF ARG2L, W
SUBWF RES2
MOVF ARG2H, W
SUBWFB RES3
;

CONT_CODE
:

```

8.0 INTERRUPTS

Members of the PIC18F85J90 family of devices have multiple interrupt sources and an interrupt priority feature that allows most interrupt sources to be assigned a high priority level or a low priority level. The high priority interrupt vector is at 0008h and the low priority interrupt vector is at 0018h. High priority interrupt events will interrupt any low priority interrupts that may be in progress.

There are thirteen registers which are used to control interrupt operation. These registers are:

- RCON
- INTCON
- INTCON2
- INTCON3
- PIR1, PIR2, PIR3
- PIE1, PIE2, PIE3
- IPR1, IPR2, IPR3

It is recommended that the Microchip header files supplied with MPLAB® IDE be used for the symbolic bit names in these registers. This allows the assembler/compiler to automatically take care of the placement of these bits within the specified register.

In general, interrupt sources have three bits to control their operation. They are:

- **Flag bit** to indicate that an interrupt event occurred
- **Enable bit** that allows program execution to branch to the interrupt vector address when the flag bit is set
- **Priority bit** to select high priority or low priority

The interrupt priority feature is enabled by setting the IPEN bit (RCON<7>). When interrupt priority is enabled, there are two bits which enable interrupts globally. Setting the GIEH bit (INTCON<7>) enables all interrupts that have the priority bit set (high priority). Setting the GIEL bit (INTCON<6>) enables all interrupts that have the priority bit cleared (low priority). When the interrupt flag, enable bit and appropriate global interrupt enable bit are set, the interrupt will vector immediately to address 0008h or 0018h, depending on the priority bit setting. Individual interrupts can be disabled through their corresponding enable bits.

When the IPEN bit is cleared (default state), the interrupt priority feature is disabled and interrupts are compatible with PIC® mid-range devices. In Compatibility mode, the interrupt priority bits for each source have no effect. INTCON<6> is the PEIE bit which enables/disables all peripheral interrupt sources. INTCON<7> is the GIE bit which enables/disables all interrupt sources. All interrupts branch to address 0008h in Compatibility mode.

When an interrupt is responded to, the global interrupt enable bit is cleared to disable further interrupts. If the IPEN bit is cleared, this is the GIE bit. If interrupt priority levels are used, this will be either the GIEH or GIEL bit. High priority interrupt sources can interrupt a low priority interrupt. Low priority interrupts are not processed while high priority interrupts are in progress.

The return address is pushed onto the stack and the PC is loaded with the interrupt vector address (0008h or 0018h). Once in the Interrupt Service Routine, the source(s) of the interrupt can be determined by polling the interrupt flag bits. The interrupt flag bits must be cleared in software before re-enabling interrupts to avoid recursive interrupts.

The “return from interrupt” instruction, RETFIE, exits the interrupt routine and sets the GIE bit (GIEH or GIEL if priority levels are used) which re-enables interrupts.

For external interrupt events, such as the INT pins or the PORTB input change interrupt, the interrupt latency will be three to four instruction cycles. The exact latency is the same for one or two-cycle instructions. Individual interrupt flag bits are set regardless of the status of their corresponding enable bit or the GIE bit.

Note: Do not use the MOVFF instruction to modify any of the Interrupt Control registers while **any** interrupt is enabled. Doing so may cause erratic microcontroller behavior.

PIC18F85J90 FAMILY

FIGURE 8-1: PIC18F85J90 FAMILY INTERRUPT LOGIC

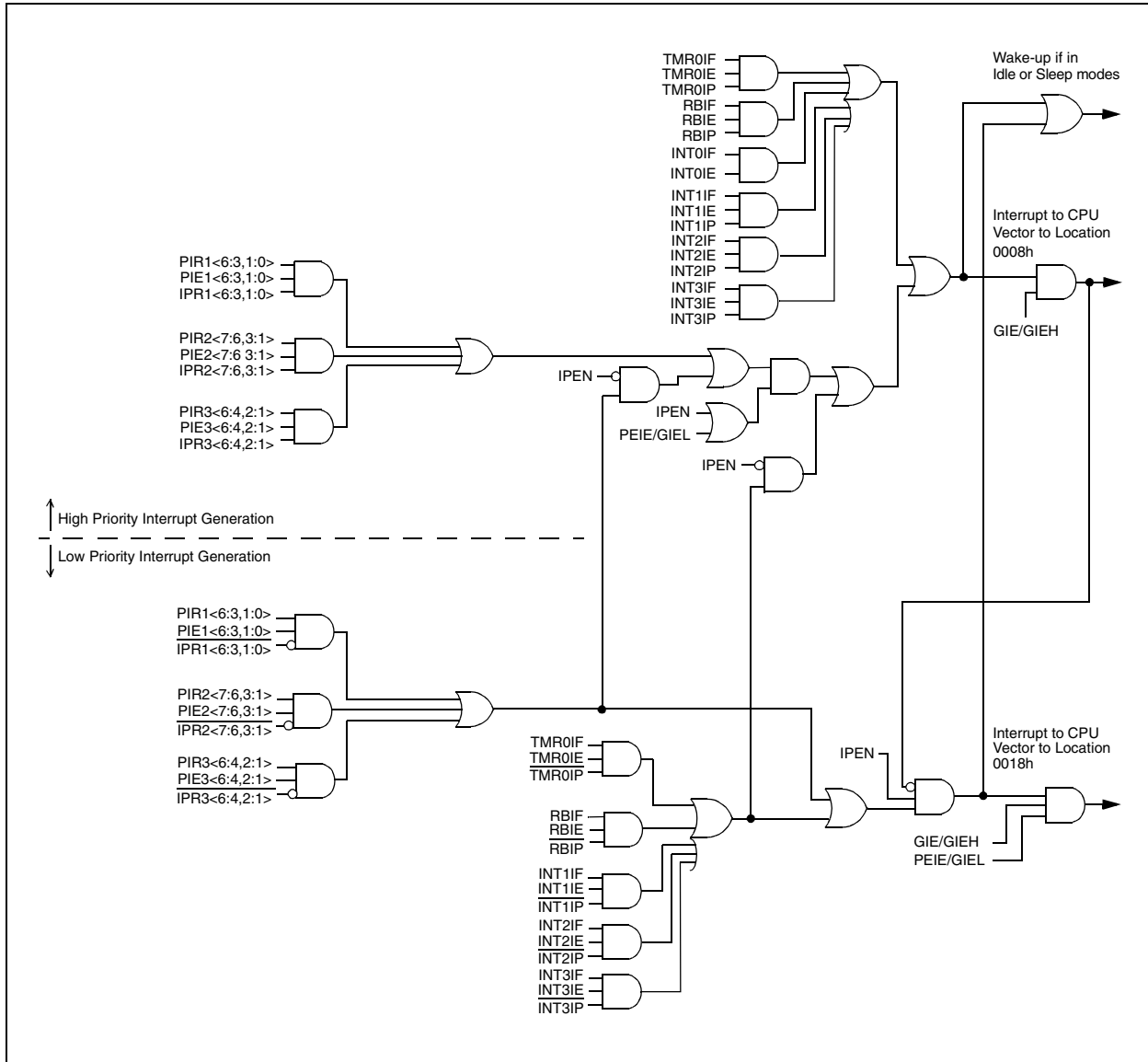

PIC18F85J90 FAMILY

8.1 INTCON Registers

The INTCON registers are readable and writable registers which contain various enable, priority and flag bits.

Note: Interrupt flag bits are set when an interrupt condition occurs regardless of the state of its corresponding enable bit or the global interrupt enable bit. User software should ensure the appropriate interrupt flag bits are clear prior to enabling an interrupt. This feature allows for software polling.

REGISTER 8-1: INTCON: INTERRUPT CONTROL REGISTER

R/W-0	R/W-0	R/W-0	R/W-0	R/W-0	R/W-0	R/W-0	R/W-x
GIE/GIEH	PEIE/GIEL	TMR0IE	INT0IE	RBIE	TMR0IF	INT0IF	RBIF ⁽¹⁾
bit 7							bit 0

Legend:

R = Readable bit	W = Writable bit	U = Unimplemented bit, read as '0'
-n = Value at POR	'1' = Bit is set	'0' = Bit is cleared x = Bit is unknown

- bit 7 **GIE/GIEH:** Global Interrupt Enable bit
When IPEN = 0:
 1 = Enables all unmasked interrupts
 0 = Disables all interrupts
When IPEN = 1:
 1 = Enables all high priority interrupts
 0 = Disables all interrupts
- bit 6 **PEIE/GIEL:** Peripheral Interrupt Enable bit
When IPEN = 0:
 1 = Enables all unmasked peripheral interrupts
 0 = Disables all peripheral interrupts
When IPEN = 1:
 1 = Enables all low priority peripheral interrupts
 0 = Disables all low priority peripheral interrupts
- bit 5 **TMR0IE:** TMR0 Overflow Interrupt Enable bit
 1 = Enables the TMR0 overflow interrupt
 0 = Disables the TMR0 overflow interrupt
- bit 4 **INT0IE:** INT0 External Interrupt Enable bit
 1 = Enables the INT0 external interrupt
 0 = Disables the INT0 external interrupt
- bit 3 **RBIE:** RB Port Change Interrupt Enable bit
 1 = Enables the RB port change interrupt
 0 = Disables the RB port change interrupt
- bit 2 **TMR0IF:** TMR0 Overflow Interrupt Flag bit
 1 = TMR0 register has overflowed (must be cleared in software)
 0 = TMR0 register did not overflow
- bit 1 **INT0IF:** INT0 External Interrupt Flag bit
 1 = The INT0 external interrupt occurred (must be cleared in software)
 0 = The INT0 external interrupt did not occur
- bit 0 **RBIF:** RB Port Change Interrupt Flag bit⁽¹⁾
 1 = At least one of the RB7:RB4 pins changed state (must be cleared in software)
 0 = None of the RB7:RB4 pins have changed state

Note 1: A mismatch condition will continue to set this bit. Reading PORTB will end the mismatch condition and allow the bit to be cleared.

PIC18F85J90 FAMILY

REGISTER 8-2: INTCON2: INTERRUPT CONTROL REGISTER 2

R/W-1	R/W-1	R/W-1	R/W-1	R/W-1	R/W-1	R/W-1	R/W-1
$\overline{\text{RBPU}}$	INTEDG0	INTEDG1	INTEDG2	INTEDG3	TMR0IP	INT3IP	RBIP
bit 7							bit 0

Legend:

R = Readable bit W = Writable bit U = Unimplemented bit, read as '0'
 -n = Value at POR '1' = Bit is set '0' = Bit is cleared x = Bit is unknown

- bit 7 **$\overline{\text{RBPU}}$** : PORTB Pull-up Enable bit
 1 = All PORTB pull-ups are disabled
 0 = PORTB pull-ups are enabled by individual port latch values
- bit 6 **INTEDG0**: External Interrupt 0 Edge Select bit
 1 = Interrupt on rising edge
 0 = Interrupt on falling edge
- bit 5 **INTEDG1**: External Interrupt 1 Edge Select bit
 1 = Interrupt on rising edge
 0 = Interrupt on falling edge
- bit 4 **INTEDG2**: External Interrupt 2 Edge Select bit
 1 = Interrupt on rising edge
 0 = Interrupt on falling edge
- bit 3 **INTEDG3**: External Interrupt 3 Edge Select bit
 1 = Interrupt on rising edge
 0 = Interrupt on falling edge
- bit 2 **TMR0IP**: TMR0 Overflow Interrupt Priority bit
 1 = High priority
 0 = Low priority
- bit 1 **INT3IP**: INT3 External Interrupt Priority bit
 1 = High priority
 0 = Low priority
- bit 0 **RBIP**: RB Port Change Interrupt Priority bit
 1 = High priority
 0 = Low priority

Note: Interrupt flag bits are set when an interrupt condition occurs regardless of the state of its corresponding enable bit or the global interrupt enable bit. User software should ensure the appropriate interrupt flag bits are clear prior to enabling an interrupt. This feature allows for software polling.

PIC18F85J90 FAMILY

REGISTER 8-3: INTCON3: INTERRUPT CONTROL REGISTER 3

R/W-1	R/W-1	R/W-0	R/W-0	R/W-0	R/W-0	R/W-0	R/W-0
INT2IP	INT1IP	INT3IE	INT2IE	INT1IE	INT3IF	INT2IF	INT1IF
bit 7							bit 0

Legend:

R = Readable bit

W = Writable bit

U = Unimplemented bit, read as '0'

-n = Value at POR

'1' = Bit is set

'0' = Bit is cleared

x = Bit is unknown

- bit 7 **INT2IP:** INT2 External Interrupt Priority bit
 1 = High priority
 0 = Low priority
- bit 6 **INT1IP:** INT1 External Interrupt Priority bit
 1 = High priority
 0 = Low priority
- bit 5 **INT3IE:** INT3 External Interrupt Enable bit
 1 = Enables the INT3 external interrupt
 0 = Disables the INT3 external interrupt
- bit 4 **INT2IE:** INT2 External Interrupt Enable bit
 1 = Enables the INT2 external interrupt
 0 = Disables the INT2 external interrupt
- bit 3 **INT1IE:** INT1 External Interrupt Enable bit
 1 = Enables the INT1 external interrupt
 0 = Disables the INT1 external interrupt
- bit 2 **INT3IF:** INT3 External Interrupt Flag bit
 1 = The INT3 external interrupt occurred (must be cleared in software)
 0 = The INT3 external interrupt did not occur
- bit 1 **INT2IF:** INT2 External Interrupt Flag bit
 1 = The INT2 external interrupt occurred (must be cleared in software)
 0 = The INT2 external interrupt did not occur
- bit 0 **INT1IF:** INT1 External Interrupt Flag bit
 1 = The INT1 external interrupt occurred (must be cleared in software)
 0 = The INT1 external interrupt did not occur

Note: Interrupt flag bits are set when an interrupt condition occurs regardless of the state of its corresponding enable bit or the global interrupt enable bit. User software should ensure the appropriate interrupt flag bits are clear prior to enabling an interrupt. This feature allows for software polling.

PIC18F85J90 FAMILY

8.2 PIR Registers

The PIR registers contain the individual flag bits for the peripheral interrupts. Due to the number of peripheral interrupt sources, there are three Peripheral Interrupt Request (Flag) registers (PIR1, PIR2, PIR3).

Note 1: Interrupt flag bits are set when an interrupt condition occurs regardless of the state of its corresponding enable bit or the Global Interrupt Enable bit, GIE (INTCON<7>).

2: User software should ensure the appropriate interrupt flag bits are cleared prior to enabling an interrupt and after servicing that interrupt.

REGISTER 8-4: PIR1: PERIPHERAL INTERRUPT REQUEST (FLAG) REGISTER 1

U-0	R/W-0	R-0	R-0	R/W-0	U-0	R/W-0	R/W-0
—	ADIF	RC1IF	TX1IF	SSPIF	—	TMR2IF	TMR1IF
bit 7							bit 0

Legend:

R = Readable bit W = Writable bit U = Unimplemented bit, read as '0'
 -n = Value at POR '1' = Bit is set '0' = Bit is cleared x = Bit is unknown

- bit 7 **Unimplemented:** Read as '0'
- bit 6 **ADIF:** A/D Converter Interrupt Flag bit
 1 = An A/D conversion completed (must be cleared in software)
 0 = The A/D conversion is not complete
- bit 5 **RC1IF:** EUSART Receive Interrupt Flag bit
 1 = The EUSART receive buffer, RCREG1, is full (cleared when RCREG1 is read)
 0 = The EUSART receive buffer is empty
- bit 4 **TX1IF:** EUSART Transmit Interrupt Flag bit
 1 = The EUSART transmit buffer, TXREG1, is empty (cleared when TXREG1 is written)
 0 = The EUSART transmit buffer is full
- bit 3 **SSPIF:** Master Synchronous Serial Port Interrupt Flag bit
 1 = The transmission/reception is complete (must be cleared in software)
 0 = Waiting to transmit/receive
- bit 2 **Unimplemented:** Read as '0'
- bit 1 **TMR2IF:** TMR2 to PR2 Match Interrupt Flag bit
 1 = TMR2 to PR2 match occurred (must be cleared in software)
 0 = No TMR2 to PR2 match occurred
- bit 0 **TMR1IF:** TMR1 Overflow Interrupt Flag bit
 1 = TMR1 register overflowed (must be cleared in software)
 0 = TMR1 register did not overflow

PIC18F85J90 FAMILY

REGISTER 8-5: PIR2: PERIPHERAL INTERRUPT REQUEST (FLAG) REGISTER 2

R/W-0	R/W-0	U-0	U-0	R/W-0	R/W-0	R/W-0	U-0
OSCFIF	CMIF	—	—	BCLIF	LVDIF	TMR3IF	—
bit 7							bit 0

Legend:

R = Readable bit

W = Writable bit

U = Unimplemented bit, read as '0'

-n = Value at POR

'1' = Bit is set

'0' = Bit is cleared

x = Bit is unknown

- bit 7 **OSCFIF:** Oscillator Fail Interrupt Flag bit
1 = Device oscillator failed, clock input has changed to INTOSC (must be cleared in software)
0 = Device clock operating
- bit 6 **CMIF:** Comparator Interrupt Flag bit
1 = Comparator input has changed (must be cleared in software)
0 = Comparator input has not changed
- bit 5-4 **Unimplemented:** Read as '0'
- bit 3 **BCLIF:** Bus Collision Interrupt Flag bit
1 = A bus collision occurred (must be cleared in software)
0 = No bus collision occurred
- bit 2 **LVDIF:** Low-Voltage Detect Interrupt Flag bit
1 = A low-voltage condition occurred (must be cleared in software)
0 = The device voltage is above the regulator's low-voltage trip point
- bit 1 **TMR3IF:** TMR3 Overflow Interrupt Flag bit
1 = TMR3 register overflowed (must be cleared in software)
0 = TMR3 register did not overflow
- bit 0 **Unimplemented:** Read as '0'

PIC18F85J90 FAMILY

REGISTER 8-6: PIR3: PERIPHERAL INTERRUPT REQUEST (FLAG) REGISTER 3

U-0	R/W-0	R-0	R-0	U-0	R/W-0	R/W-0	U-0
—	LCDIF	RC2IF	TX2IF	—	CCP2IF	CCP1IF	—
bit 7							bit 0

Legend:

R = Readable bit	W = Writable bit	U = Unimplemented bit, read as '0'
-n = Value at POR	'1' = Bit is set	'0' = Bit is cleared x = Bit is unknown

- bit 7 **Unimplemented:** Read as '0'
- bit 6 **LCDIF:** LCD Interrupt Flag bit (valid when Type-B waveform with Non-Static mode is selected)
 1 = LCD data of all COMs is output (must be cleared in software)
 0 = LCD data of all COMs is not yet output
- bit 5 **RC2IF:** AUSART Receive Interrupt Flag bit
 1 = The AUSART receive buffer, RCREG2, is full (cleared when RCREG2 is read)
 0 = The AUSART receive buffer is empty
- bit 4 **TX2IF:** AUSART Transmit Interrupt Flag bit
 1 = The AUSART transmit buffer, TXREG2, is empty (cleared when TXREG2 is written)
 0 = The AUSART transmit buffer is full
- bit 3 **Unimplemented:** Read as '0'
- bit 2 **CCP2IF:** CCP2 Interrupt Flag bit
Capture mode:
 1 = A TMR1/TMR3 register capture occurred (must be cleared in software)
 0 = No TMR1/TMR3 register capture occurred
Compare mode:
 1 = A TMR1/TMR3 register compare match occurred (must be cleared in software)
 0 = No TMR1/TMR3 register compare match occurred
PWM mode:
 Unused in this mode.
- bit 1 **CCP1IF:** CCP1 Interrupt Flag bit
Capture mode:
 1 = A TMR1/TMR3 register capture occurred (must be cleared in software)
 0 = No TMR1/TMR3 register capture occurred
Compare mode:
 1 = A TMR1/TMR3 register compare match occurred (must be cleared in software)
 0 = No TMR1/TMR3 register compare match occurred
PWM mode:
 Unused in this mode.
- bit 0 **Unimplemented:** Read as '0'

8.3 PIE Registers

The PIE registers contain the individual enable bits for the peripheral interrupts. Due to the number of peripheral interrupt sources, there are three Peripheral Interrupt Enable registers (PIE1, PIE2, PIE3). When IPEN = 0, the PEIE bit must be set to enable any of these peripheral interrupts.

REGISTER 8-7: PIE1: PERIPHERAL INTERRUPT ENABLE REGISTER 1

U-0	R/W-0	R/W-0	R/W-0	R/W-0	U-0	R/W-0	R/W-0
—	ADIE	RC1IE	TX1IE	SSPIE	—	TMR2IE	TMR1IE
bit 7						bit 0	

Legend:

R = Readable bit	W = Writable bit	U = Unimplemented bit, read as '0'
-n = Value at POR	'1' = Bit is set	'0' = Bit is cleared
		x = Bit is unknown

- bit 7 **Unimplemented:** Read as '0'
- bit 6 **ADIE:** A/D Converter Interrupt Enable bit
1 = Enables the A/D interrupt
0 = Disables the A/D interrupt
- bit 5 **RC1IE:** EUSART Receive Interrupt Enable bit
1 = Enables the EUSART receive interrupt
0 = Disables the EUSART receive interrupt
- bit 4 **TX1IE:** EUSART Transmit Interrupt Enable bit
1 = Enables the EUSART transmit interrupt
0 = Disables the EUSART transmit interrupt
- bit 3 **SSPIE:** Master Synchronous Serial Port Interrupt Enable bit
1 = Enables the MSSP interrupt
0 = Disables the MSSP interrupt
- bit 2 **Unimplemented:** Read as '0'
- bit 1 **TMR2IE:** TMR2 to PR2 Match Interrupt Enable bit
1 = Enables the TMR2 to PR2 match interrupt
0 = Disables the TMR2 to PR2 match interrupt
- bit 0 **TMR1IE:** TMR1 Overflow Interrupt Enable bit
1 = Enables the TMR1 overflow interrupt
0 = Disables the TMR1 overflow interrupt

PIC18F85J90 FAMILY

REGISTER 8-8: PIE2: PERIPHERAL INTERRUPT ENABLE REGISTER 2

R/W-0	R/W-0	U-0	U-0	R/W-0	R/W-0	R/W-0	U-0
OSCFIE	CMIE	—	—	BCLIE	LVDIE	TMR3IE	—
bit 7							bit 0

Legend:

R = Readable bit

W = Writable bit

U = Unimplemented bit, read as '0'

-n = Value at POR

'1' = Bit is set

'0' = Bit is cleared

x = Bit is unknown

- bit 7 **OSCFIE:** Oscillator Fail Interrupt Enable bit
 1 = Enabled
 0 = Disabled
- bit 6 **CMIE:** Comparator Interrupt Enable bit
 1 = Enabled
 0 = Disabled
- bit 5-4 **Unimplemented:** Read as '0'
- bit 3 **BCLIE:** Bus Collision Interrupt Enable bit
 1 = Enabled
 0 = Disabled
- bit 2 **LVDIE:** Low-Voltage Detect Interrupt Enable bit
 1 = Enabled
 0 = Disabled
- bit 1 **TMR3IE:** TMR3 Overflow Interrupt Enable bit
 1 = Enabled
 0 = Disabled
- bit 0 **Unimplemented:** Read as '0'

PIC18F85J90 FAMILY

REGISTER 8-9: PIE3: PERIPHERAL INTERRUPT ENABLE REGISTER 3

U-0	R/W-0	R-0	R-0	U-0	R/W-0	R/W-0	U-0
—	LCDIE	RC2IE	TX2IE	—	CCP2IE	CCP1IE	—
bit 7							bit 0

Legend:

R = Readable bit

W = Writable bit

U = Unimplemented bit, read as '0'

-n = Value at POR

'1' = Bit is set

'0' = Bit is cleared

x = Bit is unknown

bit 7 **Unimplemented:** Read as '0'

bit 6 **LCDIE:** LCD Interrupt Enable bit (valid when Type-B waveform with Non-Static mode is selected)

1 = Enabled

0 = Disabled

bit 5 **RC2IE:** AUSART Receive Interrupt Enable bit

1 = Enabled

0 = Disabled

bit 4 **TX2IE:** AUSART Transmit Interrupt Enable bit

1 = Enabled

0 = Disabled

bit 3 **Unimplemented:** Read as '0'

bit 2 **CCP2IE:** CCP2 Interrupt Enable bit

1 = Enabled

0 = Disabled

bit 1 **CCP1IE:** CCP1 Interrupt Enable bit

1 = Enables the CCP1 interrupt

0 = Disables the CCP1 interrupt

bit 0 **Unimplemented:** Read as '0'

PIC18F85J90 FAMILY

8.4 IPR Registers

The IPR registers contain the individual priority bits for the peripheral interrupts. Due to the number of peripheral interrupt sources, there are three Peripheral Interrupt Priority registers (IPR1, IPR2, IPR3). Using the priority bits requires that the Interrupt Priority Enable (IPEN) bit be set.

REGISTER 8-10: IPR1: PERIPHERAL INTERRUPT PRIORITY REGISTER 1

U-0	R/W-1	R/W-1	R/W-1	R/W-1	U-0	R/W-1	R/W-1
—	ADIP	RC1IP	TX1IP	SSPIP	—	TMR2IP	TMR1IP
bit 7							bit 0

Legend:

R = Readable bit

W = Writable bit

U = Unimplemented bit, read as '0'

-n = Value at POR

'1' = Bit is set

'0' = Bit is cleared

x = Bit is unknown

- bit 7 **Unimplemented:** Read as '0'
- bit 6 **ADIP:** A/D Converter Interrupt Priority bit
 1 = High priority
 0 = Low priority
- bit 5 **RC1IP:** EUSART Receive Interrupt Priority bit
 1 = High priority
 0 = Low priority
- bit 4 **TX1IP:** EUSART Transmit Interrupt Priority bit
 1 = High priority
 0 = Low priority
- bit 3 **SSPIP:** Master Synchronous Serial Port Interrupt Priority bit
 1 = High priority
 0 = Low priority
- bit 2 **Unimplemented:** Read as '0'
- bit 1 **TMR2IP:** TMR2 to PR2 Match Interrupt Priority bit
 1 = High priority
 0 = Low priority
- bit 0 **TMR1IP:** TMR1 Overflow Interrupt Priority bit
 1 = High priority
 0 = Low priority

PIC18F85J90 FAMILY

REGISTER 8-11: IPR2: PERIPHERAL INTERRUPT PRIORITY REGISTER 2

R/W-1	R/W-1	U-0	U-0	R/W-1	R/W-1	R/W-1	U-0
OSCFIP	CMIP	—	—	BCLIP	LVDIP	TMR3IP	—
bit 7							bit 0

Legend:

R = Readable bit

W = Writable bit

U = Unimplemented bit, read as '0'

-n = Value at POR

'1' = Bit is set

'0' = Bit is cleared

x = Bit is unknown

- bit 7 **OSCFIP:** Oscillator Fail Interrupt Priority bit
 1 = High priority
 0 = Low priority
- bit 6 **CMIP:** Comparator Interrupt Priority bit
 1 = High priority
 0 = Low priority
- bit 5-4 **Unimplemented:** Read as '0'
- bit 3 **BCLIP:** Bus Collision Interrupt Priority bit
 1 = High priority
 0 = Low priority
- bit 2 **LVDIP:** Low-Voltage Detect Interrupt Priority bit
 1 = High priority
 0 = Low priority
- bit 1 **TMR3IP:** TMR3 Overflow Interrupt Priority bit
 1 = High priority
 0 = Low priority
- bit 0 **Unimplemented:** Read as '0'

PIC18F85J90 FAMILY

REGISTER 8-12: IPR3: PERIPHERAL INTERRUPT PRIORITY REGISTER 3

U-0	R/W-0	R-0	R-0	U-0	R/W-1	R/W-1	U-0
—	LCDIP	RC2IP	TX2IP	—	CCP2IP	CCP1IP	—
bit 7							bit 0

Legend:

R = Readable bit

W = Writable bit

U = Unimplemented bit, read as '0'

-n = Value at POR

'1' = Bit is set

'0' = Bit is cleared

x = Bit is unknown

- bit 7 **Unimplemented:** Read as '0'
- bit 6 **LCDIP:** LCD Interrupt Priority bit (valid when Type-B waveform with Non-Static mode is selected)
 1 = High priority
 0 = Low priority
- bit 5 **RC2IP:** AUSART Receive Priority Flag bit
 1 = High priority
 0 = Low priority
- bit 4 **TX2IP:** AUSART Transmit Interrupt Priority bit
 1 = High priority
 0 = Low priority
- bit 3 **Unimplemented:** Read as '0'
- bit **CCP2IP:** CCP2 Interrupt Priority bit
 1 = High priority
 0 = Low priority
- bit **CCP1IP:** CCP1 Interrupt Priority bit
 1 = High priority
 0 = Low priority
- bit 0 **Unimplemented:** Read as '0'

8.5 RCON Register

The RCON register contains bits used to determine the cause of the last Reset or wake-up from Idle or Sleep modes. RCON also contains the bit that enables interrupt priorities (IPEN).

REGISTER 8-13: RCON: RESET CONTROL REGISTER

R/W-0	U-0	U-0	R/W-1	R-1	R-1	R/W-0	R/W-0
IPEN	—	—	\overline{RI}	\overline{TO}	\overline{PD}	\overline{POR}	\overline{BOR}
bit 7							bit 0

Legend:

R = Readable bit	W = Writable bit	U = Unimplemented bit, read as '0'
-n = Value at POR	'1' = Bit is set	'0' = Bit is cleared
		x = Bit is unknown

- bit 7 **IPEN:** Interrupt Priority Enable bit
 1 = Enable priority levels on interrupts
 0 = Disable priority levels on interrupts (PIC16CXXX Compatibility mode)
- bit 6-5 **Unimplemented:** Read as '0'
- bit 4 **\overline{RI} :** RESET Instruction Flag bit
 For details of bit operation, see Register 4-1.
- bit 3 **\overline{TO} :** Watchdog Timer Time-out Flag bit
 For details of bit operation, see Register 4-1.
- bit 2 **\overline{PD} :** Power-Down Detection Flag bit
 For details of bit operation, see Register 4-1.
- bit 1 **\overline{POR} :** Power-on Reset Status bit
 For details of bit operation, see Register 4-1.
- bit 0 **\overline{BOR} :** Brown-out Reset Status bit
 For details of bit operation, see Register 4-1.

PIC18F85J90 FAMILY

8.6 INTx Pin Interrupts

External interrupts on the RB0/INT0, RB1/INT1, RB2/INT2 and RB3/INT3 pins are edge-triggered. If the corresponding INTEDGx bit in the INTCON2 register is set (= 1), the interrupt is triggered by a rising edge; if the bit is clear, the trigger is on the falling edge. When a valid edge appears on the RBx/INTx pin, the corresponding flag bit, INTxIF, is set. This interrupt can be disabled by clearing the corresponding enable bit, INTxIE. Flag bit, INTxIF, must be cleared in software in the Interrupt Service Routine before re-enabling the interrupt.

All external interrupts (INT0, INT1, INT2 and INT3) can wake-up the processor from the power-managed modes if bit INTxIE was set prior to going into the power-managed modes. If the Global Interrupt Enable bit, GIE, is set, the processor will branch to the interrupt vector following wake-up.

Interrupt priority for INT1, INT2 and INT3 is determined by the value contained in the interrupt priority bits, INT1IP (INTCON3<6>), INT2IP (INTCON3<7>) and INT3IP (INTCON2<1>). There is no priority bit associated with INT0. It is always a high priority interrupt source.

8.7 TMR0 Interrupt

In 8-bit mode (which is the default), an overflow in the TMR0 register (FFh → 00h) will set flag bit, TMR0IF. In 16-bit mode, an overflow in the TMR0H:TMR0L register pair (FFFFh → 0000h) will set TMR0IF. The interrupt can be enabled/disabled by setting/clearing enable bit, TMR0IE (INTCON<5>). Interrupt priority for Timer0 is determined by the value contained in the interrupt priority bit, TMR0IP (INTCON2<2>). See **Section 10.0 “Timer0 Module”** for further details on the Timer0 module.

8.8 PORTB Interrupt-on-Change

An input change on PORTB<7:4> sets flag bit, RBIF (INTCON<0>). The interrupt can be enabled/disabled by setting/clearing enable bit, RBIE (INTCON<3>). Interrupt priority for PORTB interrupt-on-change is determined by the value contained in the interrupt priority bit, RBIP (INTCON2<0>).

8.9 Context Saving During Interrupts

During interrupts, the return PC address is saved on the stack. Additionally, the WREG, STATUS and BSR registers are saved on the Fast Return Stack. If a fast return from interrupt is not used (see **Section 5.3 “Data Memory Organization”**), the user may need to save the WREG, STATUS and BSR registers on entry to the Interrupt Service Routine. Depending on the user’s application, other registers may also need to be saved. Example 8-1 saves and restores the WREG, STATUS and BSR registers during an Interrupt Service Routine.

EXAMPLE 8-1: SAVING STATUS, WREG AND BSR REGISTERS IN RAM

```
MOVWF  W_TEMP          ; W_TEMP is in virtual bank
MOVFF  STATUS, STATUS_TEMP ; STATUS_TEMP located anywhere
MOVFF  BSR, BSR_TEMP    ; BSR_TEMP located anywhere
;
; USER ISR CODE
;
MOVFF  BSR_TEMP, BSR    ; Restore BSR
MOVF   W_TEMP, W        ; Restore WREG
MOVFF  STATUS_TEMP, STATUS ; Restore STATUS
```

PIC18F85J90 FAMILY

9.0 I/O PORTS

Depending on the device selected and features enabled, there are up to nine ports available. Some pins of the I/O ports are multiplexed with an alternate function from the peripheral features on the device. In general, when a peripheral is enabled, that pin may not be used as a general purpose I/O pin.

Each port has three memory mapped registers for its operation:

- TRIS register (Data Direction register)
- PORT register (reads the levels on the pins of the device)
- LAT register (Output Latch register)

Reading the PORT register reads the current status of the pins, whereas writing to the PORT register writes to the Output Latch (LAT) register.

Setting a TRIS bit (= 1) makes the corresponding PORT pin an input (i.e., put the corresponding output driver in a high-impedance mode). Clearing a TRIS bit (= 0) makes the corresponding PORT pin an output (i.e., put the contents of the corresponding LAT bit on the selected pin).

The Data Latch (LAT register) is useful for read-modify-write operations on the value that the I/O pins are driving. Read-modify-write operations on the LAT register read and write the latched output value for the PORT register.

A simplified model of a generic I/O port, without the interfaces to other peripherals, is shown in Figure 9-1.

FIGURE 9-1: GENERIC I/O PORT OPERATION

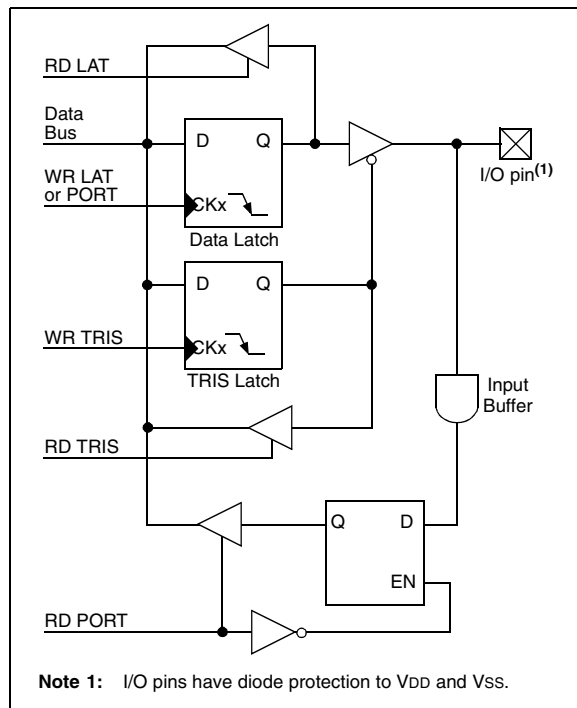

9.1 I/O Port Pin Capabilities

When developing an application, the capabilities of the port pins must be considered. Outputs on some pins have higher output drive strength than others. Similarly, some pins can tolerate higher than VDD input levels.

9.1.1 INPUT PINS AND VOLTAGE CONSIDERATIONS

The voltage tolerance of pins used as device inputs is dependent on the pin's input function. Pins that are used as digital only inputs are able to handle DC voltages up to 5.5V, a level typical for digital logic circuits. In contrast, pins that also have analog input functions of any kind can only tolerate voltages up to VDD. Voltage excursions beyond VDD on these pins should be avoided.

Table 9-1 summarizes the input voltage capabilities. Refer to **Section 25.0 "Electrical Characteristics"** for more details.

TABLE 9-1: INPUT VOLTAGE TOLERANCE

PORT or Pin	Tolerated Input	Description
PORTA<7:0>	VDD	Only VDD input levels tolerated.
PORTC<1:0>		
PORTF<7:1>		
PORTB<7:0>	5.5V	Tolerates input levels above VDD, useful for most standard logic.
PORTC<7:2>		
PORTD<7:0>		
PORTE<7:0>		
PORTG<4:0>		
PORTH<7:0> ⁽¹⁾		
PORTJ<7:0> ⁽¹⁾		

Note 1: Not available on 64-pin devices.

9.1.2 PIN OUTPUT DRIVE

When used as digital I/O, the output pin drive strengths vary for groups of pins intended to meet the needs for a variety of applications. In general, there are three classes of output pins in terms of drive capability.

PORTB and PORTC, as well as PORTA<7:6>, are designed to drive higher current loads, such as LEDs. PORTD, PORTE and PORTJ can also drive LEDs but only those with smaller current requirements. PORTF, PORTG and PORTH, along with PORTA<5:0>, have the lowest drive level but are capable of driving normal digital circuit loads with a high input impedance. Regardless of which port it is located on, all output pins in LCD Segment or Common mode have sufficient output to directly drive a display.

Table 9-2 summarizes the output capabilities of the ports. Refer to the **"Absolute Maximum Ratings"** in **Section 25.0 "Electrical Characteristics"** for more details.

PIC18F85J90 FAMILY

TABLE 9-2: OUTPUT DRIVE LEVELS FOR VARIOUS PORTS

Low	Medium	High
PORTA<5:0>	PORTD	PORTA<7:6>
PORTF	PORTE	PORTB
PORTG	PORTJ ⁽¹⁾	PORTC
PORTH ⁽¹⁾		

Note 1: Not available on 64-pin devices.

9.1.3 PULL-UP CONFIGURATION

Four of the I/O ports (PORTB, PORTD, PORTE and PORTJ) implement configurable weak pull-ups on all pins. These are internal pull-ups that allow floating digital input signals to be pulled to a consistent level without the use of external resistors.

The pull-ups are enabled with a single bit for each of the ports: RBPU (INTCON2<7>) for PORTB, and RDP, RPU and PJP (PORTG<7:5>) for the other ports.

9.1.4 OPEN-DRAIN OUTPUTS

The output pins for several peripherals are also equipped with a configurable, open-drain output option. This allows the peripherals to communicate with external digital logic, operating at a higher voltage level, without the use of level translators.

The open-drain option is implemented on port pins specifically associated with the data and clock outputs of the USARTs, the MSSP module (in SPI mode) and the CCP modules. This option is selectively enabled by setting the open-drain control bit for the corresponding module in TRISG and LATG. Their configuration is discussed in more detail in **Section 9.4 “PORTC, TRISC and LATC Registers”**, **Section 9.6 “PORTE, TRISE and LATE Registers”** and **Section 9.8 “PORTG, TRISG and LATG Registers”**.

When the open-drain option is required, the output pin must also be tied through an external pull-up resistor provided by the user to a higher voltage level, up to 5V (Figure 9-2). When a digital logic high signal is output, it is pulled up to the higher voltage level.

FIGURE 9-2: USING THE OPEN-DRAIN OUTPUT (USART SHOWN AS EXAMPLE)

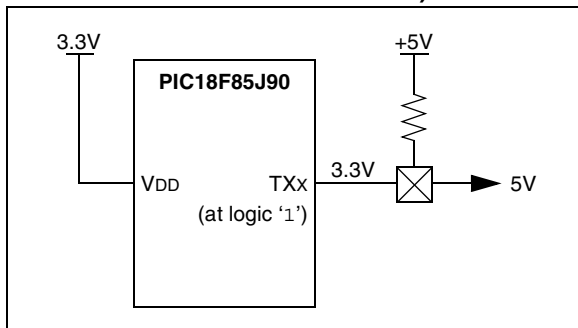

9.2 PORTA, TRISA and LATA Registers

PORTA is an 8-bit wide, bidirectional port. The corresponding Data Direction and Output Latch registers are TRISA and LATA.

RA4/T0CKI is a Schmitt Trigger input. All other PORTA pins have TTL input levels and full CMOS output drivers.

The RA4 pin is multiplexed with the Timer0 clock input and one of the LCD segment drives. RA5 and RA3:RA0 are multiplexed with analog inputs for the A/D converter.

The operation of the analog inputs as A/D converter inputs is selected by clearing or setting the PCFG3:PCFG0 control bits in the ADCON1 register. The corresponding TRISA bits control the direction of these pins, even when they are being used as analog inputs. The user must ensure the bits in the TRISA register are maintained set when using them as analog inputs.

Note: RA5 and RA3:RA0 are configured as analog inputs on any Reset and are read as '0'. RA4 is configured as a digital input.

OSC2/CLKO/RA6 and OSC1/CLKI/RA7 normally serve as the external circuit connections for the external (primary) oscillator circuit (HS Oscillator modes), or the external clock input and output (EC Oscillator modes). In these cases, RA6 and RA7 are not available as digital I/O and their corresponding TRIS and LAT bits are read as '0'. When the device is configured to use INTOSC or INTRC as the default oscillator mode (FOSC2 Configuration bit is '0'), RA6 and RA7 are automatically configured as digital I/O; the oscillator and clock in/clock out functions are disabled.

RA1, RA4 and RA5 are multiplexed with LCD segment drives, controlled by bits in the LCDSE1 and LCDSE2 registers. I/O port functionality is only available when the LCD segments are disabled.

EXAMPLE 9-1: INITIALIZING PORTA

```

CLRFB  PORTA  ; Initialize PORTA by
           ; clearing output latches
CLRFB  LATA   ; Alternate method to
           ; clear output data latches
MOVLW  07h   ; Configure A/D
MOVWF  ADCON1 ; for digital inputs
MOVLW  0BFh  ; Value used to initialize
           ; data direction
MOVWF  TRISA  ; Set RA<7, 5:0> as inputs,
           ; RA<6> as output
    
```

PIC18F85J90 FAMILY

TABLE 9-3: PORTA FUNCTIONS

Pin Name	Function	TRIS Setting	I/O	I/O Type	Description
RA0/AN0	RA0	0	O	DIG	LATA<0> data output; not affected by analog input.
		1	I	TTL	PORTA<0> data input; disabled when analog input enabled.
	AN0	1	I	ANA	A/D input channel 0. Default input configuration on POR; does not affect digital output.
RA1/AN1/SEG18	RA1	0	O	DIG	LATA<1> data output; not affected by analog input.
		1	I	TTL	PORTA<1> data input; disabled when analog input enabled.
	AN1	1	I	ANA	A/D input channel 1. Default input configuration on POR; does not affect digital output.
	SEG18	x	O	ANA	LCD segment 18 output; disables all other pin functions.
RA2/AN2/VREF-	RA2	0	O	DIG	LATA<2> data output; not affected by analog input.
		1	I	TTL	PORTA<2> data input; disabled when analog functions enabled.
	AN2	1	I	ANA	A/D input channel 2. Default input configuration on POR.
	VREF-	1	I	ANA	A/D and Comparator low reference voltage input.
RA3/AN3/VREF+	RA3	0	O	DIG	LATA<3> data output; not affected by analog input.
		1	I	TTL	PORTA<3> data input; disabled when analog input enabled.
	AN3	1	I	ANA	A/D input channel 3. Default input configuration on POR.
	VREF+	1	I	ANA	A/D and Comparator high reference voltage input.
RA4/T0CKI/SEG14	RA4	0	O	DIG	LATA<4> data output.
		1	I	ST	PORTA<4> data input. Default configuration on POR.
	T0CKI	x	I	ST	Timer0 clock input.
	SEG14	x	O	ANA	LCD segment 14 output; disables all other pin functions.
RA5/AN4/SEG15	RA5	0	O	DIG	LATA<5> data output; not affected by analog input.
		1	I	TTL	PORTA<5> data input; disabled when analog input enabled.
	AN4	1	I	ANA	A/D input channel 4. Default configuration on POR.
	SEG15	x	O	ANA	LCD segment 15 output; disables all other pin functions.
OSC2/CLKO/RA6	OSC2	x	O	ANA	Main oscillator feedback output connection (HS and HSPLL modes).
	CLKO	x	O	DIG	System cycle clock output (FOSC/4) (EC and ECPLL modes).
	RA6	0	O	DIG	LATA<6> data output; disabled when FOSC2 Configuration bit is set.
		1	I	TTL	PORTA<6> data input; disabled when FOSC2 Configuration bit is set.
OSC1/CLKI/RA7	OSC1	x	I	ANA	Main oscillator input connection (HS and HSPLL modes).
	CLKI	x	I	ANA	Main external clock source input (EC and ECPLL modes).
	RA7	0	O	DIG	LATA<7> data output; disabled when FOSC2 Configuration bit is set.
		1	I	TTL	PORTA<7> data input; disabled when FOSC2 Configuration bit is set.

Legend: O = Output, I = Input, ANA = Analog Signal, DIG = Digital Output, ST = Schmitt Trigger Buffer Input, TTL = TTL Buffer Input, x = Don't care (TRIS bit does not affect port direction or is overridden for this option).

TABLE 9-4: SUMMARY OF REGISTERS ASSOCIATED WITH PORTA

Name	Bit 7	Bit 6	Bit 5	Bit 4	Bit 3	Bit 2	Bit 1	Bit 0	Reset Values on page
PORTA	RA7 ⁽¹⁾	RA6 ⁽¹⁾	RA5	RA4	RA3	RA2	RA1	RA0	55
LATA	LATA7 ⁽¹⁾	LATA6 ⁽¹⁾	LATA5	LATA4	LATA3	LATA2	LATA1	LATA0	54
TRISA	TRISA7 ⁽¹⁾	TRISA6 ⁽¹⁾	TRISA5	TRISA4	TRISA3	TRISA2	TRISA1	TRISA0	54
ADCON1	—	—	VCFG1	VCFG0	PCFG3	PCFG2	PCFG1	PCFG0	53
LCDSE1	SE15	SE14	SE13	SE12	SE11	SE10	SE09	SE08	53
LCDSE2	SE23	SE22	SE21	SE20	SE19	SE18	SE17	SE16	53

Legend: — = unimplemented, read as '0'. Shaded cells are not used by PORTA.

Note 1: These bits are enabled depending on the oscillator mode selected. When not enabled as PORTA pins, they are disabled and read as 'x'.

PIC18F85J90 FAMILY

9.3 PORTB, TRISB and LATB Registers

PORTB is an 8-bit wide, bidirectional port. The corresponding Data Direction and Output Latch registers are TRISB and LATB. All pins on PORTB are digital only and tolerate voltages up to 5.5V.

EXAMPLE 9-2: INITIALIZING PORTB

```
CLRF   PORTB   ; Initialize PORTB by
           ; clearing output
           ; data latches
CLRF   LATB    ; Alternate method
           ; to clear output
           ; data latches
MOVLW  0CFh   ; Value used to
           ; initialize data
           ; direction
MOVWF  TRISB   ; Set RB<3:0> as inputs
           ; RB<5:4> as outputs
           ; RB<7:6> as inputs
```

Each of the PORTB pins has a weak internal pull-up. A single control bit can turn on all the pull-ups. This is performed by clearing bit RBPU (INTCON2<7>). The weak pull-up is automatically turned off when the port pin is configured as an output. The pull-ups are disabled on a Power-on Reset.

Four of the PORTB pins (RB7:RB4) have an interrupt-on-change feature. Only pins configured as inputs can cause this interrupt to occur (i.e., any RB7:RB4 pin configured as an output is excluded from the interrupt-on-change comparison). The input pins (of RB7:RB4) are compared with the old value latched on the last read of PORTB. The “mismatch” outputs of RB7:RB4 are ORed together to generate the RB Port Change Interrupt with Flag bit, RBIF (INTCON<0>).

This interrupt can wake the device from power-managed modes. The user, in the Interrupt Service Routine, can clear the interrupt in the following manner:

- a) Any read or write of PORTB (except with the MOVFF (ANY), PORTB instruction). This will end the mismatch condition.
- b) Clear flag bit, RBIF.

A mismatch condition will continue to set flag bit, RBIF. Reading PORTB will end the mismatch condition and allow flag bit, RBIF, to be cleared.

The interrupt-on-change feature is recommended for wake-up on key depression operation and operations where PORTB is only used for the interrupt-on-change feature. Polling of PORTB is not recommended while using the interrupt-on-change feature.

RB5:RB0 are also multiplexed with LCD segment drives, controlled by bits in the LCDSE1 and LCDSE3 registers. I/O port functionality is only available when the LCD segments are disabled.

PIC18F85J90 FAMILY

TABLE 9-5: PORTB FUNCTIONS

Pin Name	Function	TRIS Setting	I/O	I/O Type	Description
RB0/INT0/SEG30	RB0	0	O	DIG	LATB<0> data output.
		1	I	TTL	PORTB<0> data input; weak pull-up when $\overline{\text{RBPU}}$ bit is cleared.
	INT0	1	I	ST	External interrupt 0 input.
	SEG30	x	O	ANA	LCD segment 30 output; disables all other pin functions.
RB1/INT1/SEG8	RB1	0	O	DIG	LATB<1> data output.
		1	I	TTL	PORTB<1> data input; weak pull-up when $\overline{\text{RBPU}}$ bit is cleared.
	INT1	1	I	ST	External interrupt 1 input.
	SEG8	x	O	ANA	LCD segment 8 output; disables all other pin functions.
RB2/INT2/SEG9	RB2	0	O	DIG	LATB<2> data output.
		1	I	TTL	PORTB<2> data input; weak pull-up when $\overline{\text{RBPU}}$ bit is cleared.
	INT2	1	I	ST	External interrupt 2 input.
	SEG9	x	O	ANA	LCD segment 9 output; disables all other pin functions.
RB3/INT3/SEG10	RB3	0	O	DIG	LATB<3> data output.
		1	I	TTL	PORTB<3> data input; weak pull-up when $\overline{\text{RBPU}}$ bit is cleared.
	INT3	1	I	ST	External interrupt 3 input.
	SEG10	x	O	ANA	LCD segment 10 output; disables all other pin functions.
RB4/KBI0/SEG11	RB4	0	O	DIG	LATB<4> data output.
		1	I	TTL	PORTB<4> data input; weak pull-up when $\overline{\text{RBPU}}$ bit is cleared.
	KBI0	1	I	TTL	Interrupt-on-pin change.
	SEG11	x	O	ANA	LCD segment 11 output; disables all other pin functions.
RB5/KBI1/SEG29	RB5	0	O	DIG	LATB<5> data output.
		1	I	TTL	PORTB<5> data input; weak pull-up when $\overline{\text{RBPU}}$ bit is cleared.
	KBI1	1	I	TTL	Interrupt-on-pin change.
	SEG29	x	O	ANA	LCD segment 29 output; disables all other pin functions.
RB6/KBI2/PGC	RB6	0	O	DIG	LATB<6> data output.
		1	I	TTL	PORTB<6> data input; weak pull-up when $\overline{\text{RBPU}}$ bit is cleared.
	KBI2	1	I	TTL	Interrupt-on-pin change.
	PGC	x	I	ST	Serial execution (ICSP™) clock input for ICSP and ICD operation.
RB7/KBI3/PGD	RB7	0	O	DIG	LATB<7> data output.
		1	I	TTL	PORTB<7> data input; weak pull-up when $\overline{\text{RBPU}}$ bit is cleared.
	KBI3	1	I	TTL	Interrupt-on-pin change.
	PGD	x	O	DIG	Serial execution data output for ICSP and ICD operation.
		x	I	ST	Serial execution data input for ICSP and ICD operation.

Legend: O = Output, I = Input, ANA = Analog Signal, DIG = Digital Output, ST = Schmitt Trigger Buffer Input, TTL = TTL Buffer Input, x = Don't care (TRIS bit does not affect port direction or is overridden for this option).

PIC18F85J90 FAMILY

TABLE 9-6: SUMMARY OF REGISTERS ASSOCIATED WITH PORTB

Name	Bit 7	Bit 6	Bit 5	Bit 4	Bit 3	Bit 2	Bit 1	Bit 0	Reset Values on page
PORTB	RB7	RB6	RB5	RB4	RB3	RB2	RB1	RB0	55
LATB	LATB7	LATB6	LATB5	LATB4	LATB3	LATB2	LATB1	LATB0	54
TRISB	TRISB7	TRISB6	TRISB5	TRISB4	TRISB3	TRISB2	TRISB1	TRISB0	54
INTCON	GIE/GIEH	PEIE/GIEL	TMR0IE	INT0IE	RBIE	TMR0IF	INT0IF	RBIF	51
INTCON2	$\overline{\text{RBPU}}$	INTEDG0	INTEDG1	INTEDG2	INTEDG3	TMR0IP	INT3IP	RBIP	51
INTCON3	INT2IP	INT1IP	INT3IE	INT2IE	INT1IE	INT3IF	INT2IF	INT1IF	51
LCDSE1	SE15	SE14	SE13	SE12	SE11	SE10	SE09	SE08	53
LCDSE3	SE31	SE30	SE29	SE28	SE27	SE26	SE25	SE24	53

Legend: Shaded cells are not used by PORTB.

9.4 PORTC, TRISC and LATC Registers

PORTC is an 8-bit wide, bidirectional port. The corresponding Data Direction and Output Latch registers are TRISC and LATC. Only PORTC pins, RC2 through RC7, are digital only pins and can tolerate input voltages up to 5.5V.

PORTC is multiplexed with CCP, MSSP and EUSART peripheral functions (Table 9-7). The pins have Schmitt Trigger input buffers. The pins for CCP, SPI and EUSART are also configurable for open-drain output whenever these functions are active. Open-drain configuration is selected by setting the SPIOD, CCPxOD, and U1OD control bits (TRISG<7:5> and LATG<6>, respectively).

RC1 is normally configured as the default peripheral pin for the CCP2 module. Assignment of CCP2 is controlled by Configuration bit, CCP2MX (default state, CCP2MX = 1).

When enabling peripheral functions, care should be taken in defining TRIS bits for each PORTC pin. Some peripherals override the TRIS bit to make a pin an output, while other peripherals override the TRIS bit to make a pin an input. The user should refer to the corresponding peripheral section for the correct TRIS bit settings.

Note: These pins are configured as digital inputs on any device Reset.

The contents of the TRISC register are affected by peripheral overrides. Reading TRISC always returns the current contents, even though a peripheral device may be overriding one or more of the pins.

RC<7:1> pins are multiplexed with LCD segment drives, controlled by bits in the LCDSE1, LCDSE2, LCDSE3 and LCDSE4 registers. I/O port functionality is only available when the LCD segments are disabled.

EXAMPLE 9-3: INITIALIZING PORTC

```
CLRF    PORTC    ; Initialize PORTC by
                ; clearing output
                ; data latches
CLRF    LATC     ; Alternate method
                ; to clear output
                ; data latches
MOVLW  0CFh     ; Value used to
                ; initialize data
                ; direction
MOVWF  TRISC    ; Set RC<3:0> as inputs
                ; RC<5:4> as outputs
                ; RC<7:6> as inputs
```

PIC18F85J90 FAMILY

TABLE 9-7: PORTC FUNCTIONS

Pin Name	Function	TRIS Setting	I/O	I/O Type	Description
RC0/T1OSO/ T13CKI	RC0	0	O	DIG	LATC<0> data output.
		1	I	ST	PORTC<0> data input.
	T1OSO	x	O	ANA	Timer1 oscillator output; enabled when Timer1 oscillator enabled. Disables digital I/O and LCD segment driver.
	T13CKI	1	I	ST	Timer1/Timer3 counter input.
RC1/T1OSI/ CCP2/SEG32	RC1	0	O	DIG	LATC<1> data output.
		1	I	ST	PORTC<1> data input.
	T1OSI	x	I	ANA	Timer1 oscillator input.
	CCP2 ⁽¹⁾	0	O	DIG	CCP2 Compare/PWM output.
		1	I	ST	CCP2 Capture input.
SEG32	x	O	ANA	LCD segment 32 output; disables all other pin functions.	
RC2/CCP1/ SEG13	RC2	0	O	DIG	LATC<2> data output.
		1	I	ST	PORTC<2> data input.
	CCP1	0	O	DIG	CCP1 Compare/PWM output; takes priority over port data.
		1	I	ST	CCP1 Capture input.
	SEG13	x	O	ANA	LCD segment 13 output; disables all other pin functions.
RC3/SCK/SCL/ SEG17	RC3	0	O	DIG	LATC<3> data output.
		1	I	ST	PORTC<3> data input.
	SCK	0	O	DIG	SPI clock output (MSSP module); takes priority over port data.
		1	I	ST	SPI clock input (MSSP module).
	SCL	0	O	DIG	I ² C™ clock output (MSSP module); takes priority over port data.
		1	I	I2C	I ² C clock input (MSSP module); input type depends on module setting.
	SEG17	x	O	ANA	LCD segment 17 output; disables all other pin functions.
RC4/SDI/SDA/ SEG16	RC4	0	O	DIG	LATC<4> data output.
		1	I	ST	PORTC<4> data input.
	SDI		I	ST	SPI data input (MSSP module).
	SDA	1	O	DIG	I ² C data output (MSSP module); takes priority over port data.
		1	I	I2C	I ² C data input (MSSP module); input type depends on module setting.
SEG16	x	O	ANA	LCD segment 16 output; disables all other pin functions.	
RC5/SDO/ SEG12	RC5	0	O	DIG	LATC<5> data output.
		1	I	ST	PORTC<5> data input.
	SDO	0	O	DIG	SPI data output (MSSP module).
	SEG12	x	O	ANA	LCD segment 12 output; disables all other pin functions.
RC6/TX1/CK1/ SEG27	RC6	0	O	DIG	LATC<6> data output.
		1	I	ST	PORTC<6> data input.
	TX1	1	O	DIG	Synchronous serial data output (EUSART module); takes priority over port data.
	CK1	1	O	DIG	Synchronous serial data input (EUSART module); user must configure as an input.
		1	I	ST	Synchronous serial clock input (EUSART module).
SEG27	x	O	ANA	LCD segment 27 output; disables all other pin functions.	
RC7/RX1/DT1/ SEG28	RC7	0	O	DIG	LATC<7> data output.
		1	I	ST	PORTC<7> data input.
	RX1	1	I	ST	Asynchronous serial receive data input (EUSART module).
	DT1	1	O	DIG	Synchronous serial data output (EUSART module); takes priority over port data.
		1	I	ST	Synchronous serial data input (EUSART module); user must configure as an input.
	SEG28	x	O	ANA	LCD segment 28 output; disables all other pin functions.

Legend: O = Output, I = Input, ANA = Analog Signal, DIG = Digital Output, ST = Schmitt Trigger Buffer Input, TTL = TTL Buffer Input, I2C = I²C/SMBus Buffer Input, x = Don't care (TRIS bit does not affect port direction or is overridden for this option).

Note 1: Default assignment for CCP2 when CCP2MX Configuration bit is set.

PIC18F85J90 FAMILY

TABLE 9-8: SUMMARY OF REGISTERS ASSOCIATED WITH PORTC

Name	Bit 7	Bit 6	Bit 5	Bit 4	Bit 3	Bit 2	Bit 1	Bit 0	Reset Values on page
PORTC	RC7	RC6	RC5	RC4	RC3	RC2	RC1	RC0	55
LATC	LATC7	LATBC6	LATC5	LATCB4	LATC3	LATC2	LATC1	LATC0	54
TRISC	TRISC7	TRISC6	TRISC5	TRISC4	TRISC3	TRISC2	TRISC1	TRISC0	54
LATG	U2OD	U1OD	—	LATG4	LATG3	LATG2	LATG1	LATG0	54
TRISG	SPIOD	CCP2OD	CCP1OD	TRISG4	TRISG3	TRISG2	TRISG1	TRISG0	54
LCDSE1	SE15	SE14	SE13	SE12	SE11	SE10	SE09	SE08	53
LCDSE2	SE23	SE22	SE21	SE20	SE19	SE18	SE17	SE16	53
LCDSE3	SE31	SE30	SE29	SE28	SE27	SE26	SE25	SE24	53
LCDSE4	SE39 ⁽¹⁾	SE38 ⁽¹⁾	SE37 ⁽¹⁾	SE36 ⁽¹⁾	SE35 ⁽¹⁾	SE34 ⁽¹⁾	SE33 ⁽¹⁾	SE32	53

Legend: Shaded cells are not used by PORTC.

Note 1: Unimplemented on 64-pin devices, read as '0'.

PIC18F85J90 FAMILY

9.5 PORTD, TRISD and LATD Registers

PORTD is an 8-bit wide, bidirectional port. The corresponding Data Direction and Output Latch registers are TRISD and LATD. All pins on PORTD are digital only and tolerate voltages up to 5.5V.

All pins on PORTD are implemented with Schmitt Trigger input buffers. Each pin is individually configurable as an input or output.

Note: These pins are configured as digital inputs on any device Reset.

Each of the PORTD pins has a weak internal pull-up. A single control bit can turn off all the pull-ups. This is performed by setting bit RDPU (PORTG<7>). The weak pull-up is automatically turned off when the port pin is configured as an output. The pull-ups are disabled on all device Resets.

All of the PORTD pins are multiplexed with LCD segment drives, controlled by bits in the LCDSE0 register. I/O port functionality is only available when the LCD segments are disabled.

EXAMPLE 9-4: INITIALIZING PORTD

```
CLRF   PORTD   ; Initialize PORTD by
              ; clearing output
              ; data latches
CLRF   LATD    ; Alternate method
              ; to clear output
              ; data latches
MOVLW  0CFh   ; Value used to
              ; initialize data
              ; direction
MOVWF  TRISD   ; Set RD<3:0> as inputs
              ; RD<5:4> as outputs
              ; RD<7:6> as inputs
```

PIC18F85J90 FAMILY

TABLE 9-9: PORTD FUNCTIONS

Pin Name	Function	TRIS Setting	I/O	I/O Type	Description
RD0/SEG0	RD0	0	O	DIG	LATD<0> data output.
		1	I	ST	PORTD<0> data input.
	SEG0	x	O	ANA	LCD segment 0 output; disables all other pin functions.
RD1/SEG1	RD1	0	O	DIG	LATD<1> data output.
		1	I	ST	PORTD<1> data input.
	SEG1	x	O	ANA	LCD segment 1 output; disables all other pin functions.
RD2/SEG2	RD2	0	O	DIG	LATD<2> data output.
		1	I	ST	PORTD<2> data input.
	SEG2	x	O	ANA	LCD segment 2 output; disables all other pin functions.
RD3/SEG3	RD3	0	O	DIG	LATD<3> data output.
		1	I	ST	PORTD<3> data input.
	SEG3	x	O	ANA	LCD segment 3 output; disables all other pin functions.
RD4/SEG4	RD4	0	O	DIG	LATD<4> data output.
		1	I	ST	PORTD<4> data input.
	SEG4	x	O	ANA	LCD segment 4 output; disables all other pin functions.
RD5/SEG5	RD5	0	O	DIG	LATD<5> data output.
		1	I	ST	PORTD<5> data input.
	SEG5	x	O	ANA	LCD segment 5 output; disables all other pin functions.
RD6/SEG6	RD6	0	O	DIG	LATD<6> data output.
		1	I	ST	PORTD<6> data input.
	SEG6	x	O	ANA	LCD segment 6 output; disables all other pin functions.
RD7/SEG7	RD7	0	O	DIG	LATD<7> data output.
		1	I	ST	PORTD<7> data input.
	SEG7	x	I	ANA	LCD segment 7 output; disables all other pin functions.

Legend: O = Output, I = Input, ANA = Analog Signal, DIG = Digital Output, ST = Schmitt Trigger Buffer Input, x = Don't care (TRIS bit does not affect port direction or is overridden for this option).

TABLE 9-10: SUMMARY OF REGISTERS ASSOCIATED WITH PORTD

Name	Bit 7	Bit 6	Bit 5	Bit 4	Bit 3	Bit 2	Bit 1	Bit 0	Reset Values on page
PORTD	RD7	RD6	RD5	RD4	RD3	RD2	RD1	RD0	55
LATD	LATD7	LATD6	LATD5	LATD4	LATD3	LATD2	LATD1	LATD0	54
TRISD	TRISD7	TRISD6	TRISD5	TRISD4	TRISD3	TRISD2	TRISD1	TRISD0	54
PORTG	RDPU	REPU	RJPU ⁽¹⁾	RG4	RG3	RG2	RG1	RG0	54
LCDSE0	SE7	SE6	SE5	SE4	SE3	SE2	SE1	SE0	53

Legend: Shaded cells are not used by PORTD.

Note 1: Unimplemented on 64-pin devices, read as '0'.

PIC18F85J90 FAMILY

9.6 PORTE, TRISE and LATE Registers

PORTE is a 7-bit wide, bidirectional port. The corresponding Data Direction and Output Latch registers are TRISE and LATE. All pins on PORTE are digital only and tolerate voltages up to 5.5V.

All pins on PORTE are implemented with Schmitt Trigger input buffers. Each pin is individually configurable as an input or output. The RE7 pin is also configurable for open-drain output when CCP2 is active on this pin. Open-drain configuration is selected by setting the CCP2OD control bit (TRISG<6>)

Note: These pins are configured as digital inputs on any device Reset.

Each of the PORTE pins has a weak internal pull-up. A single control bit can turn off all the pull-ups. This is performed by setting bit, REPU (PORTG<6>). The weak pull-up is automatically turned off when the port pin is configured as an output. The pull-ups are disabled on any device Reset.

Pins RE6:RE3 are multiplexed with the LCD common drives. I/O port functions are only available on those PORTE pins depending on which commons are active. The configuration is determined by the LMUX1:LMUX0 control bits (LCDCON<1:0>). The availability is summarized in Table 9-11.

TABLE 9-11: PORTE PINS AVAILABLE IN DIFFERENT LCD DRIVE CONFIGURATIONS

LCDCON <1:0>	Active LCD Commons	PORTE Available for I/O
00	COM0	RE6, RE5, RE4
01	COM0, COM1	RE6, RE5
10	COM0, COM1 and COM2	RE6
11	All (COM0 through COM3)	None

Pins RE1 and RE0 are multiplexed with the functions of LCDBIAS2 and LCDBIAS1. When LCD bias generation is required (i.e., any application where the device is connected to an external LCD), these pins cannot be used as digital I/O.

Note: The pin corresponding to RE2 of other PIC18F parts has the function of LCDBIAS3 in this device. It cannot be used as digital I/O.

RE7 is multiplexed with LCD segment drive (SEG31) controlled by the LCDSE3<7> bit. I/O port function is only available when the segment is disabled.

RE7 can also be configured as the alternate peripheral pin for the CCP2 module. This is done by clearing the CCP2MX Configuration bit.

EXAMPLE 9-5: INITIALIZING PORTE

```
CLRF    PORTE    ; Initialize PORTE by
                ; clearing output
                ; data latches
CLRF    LATE     ; Alternate method
                ; to clear output
                ; data latches
MOVLW  03h      ; Value used to
                ; initialize data
                ; direction
MOVWF  TRISE    ; Set RE<1:0> as inputs
                ; RE<7:2> as outputs
```

PIC18F85J90 FAMILY

TABLE 9-12: PORTE FUNCTIONS

Pin Name	Function	TRIS Setting	I/O	I/O Type	Description
RE0/LCDBIAS1	RE0	0	O	DIG	LATE<0> data output.
		1	I	ST	PORTE<0> data input.
	LCDBIAS1	—	I	ANA	LCD module bias voltage input.
RE1/LCDBIAS2	RE1	0	O	DIG	LATE<1> data output.
		1	I	ST	PORTE<1> data input.
	LCDBIAS2	—	I	ANA	LCD module bias voltage input.
RE3/COM0	RE3	0	O	DIG	LATE<3> data output.
		1	I	ST	PORTE<3> data input.
	COM0	x	O	ANA	LCD Common 0 output; disables all other outputs.
RE4/COM1	RE4	0	O	DIG	LATE<4> data output.
		1	I	ST	PORTE<4> data input.
	COM1	x	O	ANA	LCD Common 1 output; disables all other outputs.
RE5/COM2	RE5	0	O	DIG	LATE<5> data output.
		1	I	ST	PORTE<5> data input.
	COM2	x	O	ANA	LCD Common 2 output; disables all other outputs.
RE6/COM3	RE6	0	O	DIG	LATE<6> data output.
		1	I	ST	PORTE<6> data input.
	COM3	x	O	ANA	LCD Common 3 output; disables all other outputs.
RE7/CCP2/ SEG31	RE7	0	O	DIG	LATE<7> data output.
		1	I	ST	PORTE<7> data input.
	CCP2 ⁽¹⁾	0	O	DIG	CCP2 Compare/PWM output; takes priority over port data.
		1	I	ST	CCP2 Capture input.
	SEG31	x	O	ANA	Segment 31 analog output for LCD; disables digital output.

Legend: O = Output, I = Input, ANA = Analog Signal, DIG = Digital Output, ST = Schmitt Trigger Buffer Input,
x = Don't care (TRIS bit does not affect port direction or is overridden for this option).

Note 1: Alternate assignment for CCP2 when CCP2MX Configuration bit is cleared.

TABLE 9-13: SUMMARY OF REGISTERS ASSOCIATED WITH PORTE

Name	Bit 7	Bit 6	Bit 5	Bit 4	Bit 3	Bit 2	Bit 1	Bit 0	Reset Values on page
PORTE	RE7	RE6	RE5	RE4	RE3	—	RE1	RE0	55
LATE	LATE7	LATE6	LATE5	LATE4	LATE3	—	LATE1	LATE0	54
TRISE	TRISE7	TRISE6	TRISE5	TRISE4	TRISE3	—	TRISE1	TRISE0	54
PORTG	RDPU	REPU	RJPU ⁽¹⁾	RG4	RG3	RG2	RG1	RG0	54
TRISG	SPIOD	CCP2OD	CCP1OD	TRISG4	TRISG3	TRISG2	TRISG1	TRISG0	54
LCDCON	LCDEN	SLPEN	WERR	—	CS1	CS0	LMUX1	LMUX0	53
LCDSE3	SE31	SE30	SE29	SE28	SE27	SE26	SE25	SE24	53

Legend: Shaded cells are not used by PORTE.

Note 1: Unimplemented on 64-pin devices, read as '0'.

PIC18F85J90 FAMILY

9.7 PORTF, LATF and TRISF Registers

PORTF is a 7-bit wide, bidirectional port. The corresponding Data Direction and Output Latch registers are TRISF and LATF. All pins on PORTF are implemented with Schmitt Trigger input buffers. Each pin is individually configurable as an input or output.

PORTF is multiplexed with analog peripheral functions, as well as LCD segments. Pins RF1 through RF6 may be used as comparator inputs or outputs by setting the appropriate bits in the CMCON register. To use RF6:RF3 as digital inputs, it is also necessary to turn off the comparators.

Note 1: On device Resets, pins RF6:RF1 are configured as analog inputs and are read as '0'.

2: To configure PORTF as digital I/O, turn off comparators and set ADCON1 value.

PORTF is also multiplexed with LCD segment drives controlled by bits in the LCDSE2 and LCDSE3 registers. I/O port functions are only available when the segments are disabled.

EXAMPLE 9-6: INITIALIZING PORTF

```
CLRF    PORTF    ; Initialize PORTF by
              ; clearing output
              ; data latches
CLRF    LATF     ; Alternate method
              ; to clear output
              ; data latches
MOVLW   07h     ;
MOVWF   CMCON   ; Turn off comparators
MOVLW   0Fh     ;
MOVWF   ADCON1  ; Set PORTF as digital I/O
MOVLW   0CEh   ; Value used to
              ; initialize data
              ; direction
MOVWF   TRISF   ; Set RF3:RF1 as inputs
              ; RF5:RF4 as outputs
              ; RF7:RF6 as inputs
```

PIC18F85J90 FAMILY

TABLE 9-14: PORTF FUNCTIONS

Pin Name	Function	TRIS Setting	I/O	I/O Type	Description
RF1/AN6/C2OUT/SEG19	RF1	0	O	DIG	LATF<1> data output; not affected by analog input.
		1	I	ST	PORTF<1> data input; disabled when analog input enabled.
	AN6	1	I	ANA	A/D input channel 6. Default configuration on POR.
	C2OUT	0	O	DIG	Comparator 2 output; takes priority over port data.
	SEG19	x	O	ANA	LCD segment 19 output; disables all other pin functions.
RF2/AN7/C1OUT/SEG20	RF2	0	O	DIG	LATF<2> data output; not affected by analog input.
		1	I	ST	PORTF<2> data input; disabled when analog input enabled.
	AN7	1	I	ANA	A/D input channel 7. Default configuration on POR.
	C1OUT	0	O	DIG	Comparator 1 output; takes priority over port data.
	SEG20	x	O	ANA	LCD segment 20 output; disables all other pin functions.
RF3/AN8/SEG21	RF3	0	O	DIG	LATF<3> data output; not affected by analog input.
		1	I	ST	PORTF<3> data input; disabled when analog input enabled.
	AN8	1	I	ANA	A/D input channel 8 and Comparator C2+ input. Default input configuration on POR; not affected by analog output.
	SEG21	x	O	ANA	LCD segment 21 output; disables all other pin functions.
RF4/AN9/SEG22	RF4	0	O	DIG	LATF<4> data output; not affected by analog input.
		1	I	ST	PORTF<4> data input; disabled when analog input enabled.
	AN9	1	I	ANA	A/D input channel 9 and Comparator C2- input. Default input configuration on POR; does not affect digital output.
	SEG22	x	O	ANA	LCD segment 22 output; disables all other pin functions.
RF5/AN10/CVREF/SEG23	RF5	0	O	DIG	LATF<5> data output; not affected by analog input. Disabled when CVREF output enabled.
		1	I	ST	PORTF<5> data input; disabled when analog input enabled. Disabled when CVREF output enabled.
	AN10	1	I	ANA	A/D input channel 10 and Comparator C1+ input. Default input configuration on POR.
	CVREF	x	O	ANA	Comparator voltage reference output. Enabling this feature disables digital I/O.
	SEG23	x	O	ANA	LCD segment 23 output; disables all other pin functions.
RF6/AN11/SEG24	RF6	0	O	DIG	LATF<6> data output; not affected by analog input.
		1	I	ST	PORTF<6> data input; disabled when analog input enabled.
	AN11	1	I	ANA	A/D input channel 11 and Comparator C1- input. Default input configuration on POR; does not affect digital output.
	SEG24	x	O	ANA	LCD segment 24 output; disables all other pin functions.
RF7/AN5/SS/SEG25	RF7	0	O	DIG	LATF<7> data output; not affected by analog input.
		1	I	ST	PORTF<7> data input; disabled when analog input enabled.
	AN5	1	I	ANA	A/D input channel 5. Default configuration on POR.
	SS	1	I	TTL	Slave select input for MSSP module.
	SEG25	x	O	ANA	LCD segment 25 output; disables all other pin functions.

Legend: O = Output, I = Input, ANA = Analog Signal, DIG = Digital Output, ST = Schmitt Trigger Buffer Input, TTL = TTL Buffer Input, x = Don't care (TRIS bit does not affect port direction or is overridden for this option).

PIC18F85J90 FAMILY

TABLE 9-15: SUMMARY OF REGISTERS ASSOCIATED WITH PORTF

Name	Bit 7	Bit 6	Bit 5	Bit 4	Bit 3	Bit 2	Bit 1	Bit 0	Reset Values on page
PORTF	RF7	RF6	RF5	RF4	RF3	RF2	RF1	—	54
LATF	LATF7	LATF6	LATF5	LATF4	LATF3	LATF2	LATF1	—	54
TRISF	TRISF7	TRISF6	TRISF5	TRISF4	TRISF3	TRISF2	TRISF1	—	54
ADCON1	—	—	VCFG1	VCFG0	PCFG3	PCFG2	PCFG1	PCFG0	53
CMCON	C2OUT	C1OUT	C2INV	C1INV	CIS	CM2	CM1	CM0	53
CVRCON	CVREN	CVROE	CVRR	CVRSS	CVR3	CVR2	CVR1	CVR0	53
LCDSE2	SE23	SE22	SE21	SE20	SE19	SE18	SE17	SE16	53
LCDSE3	SE31	SE30	SE29	SE28	SE27	SE26	SE25	SE24	53

Legend: — = unimplemented, read as '0'. Shaded cells are not used by PORTF.

9.8 PORTG, TRISG and LATG Registers

PORTG is a 5-bit wide, bidirectional port. The corresponding Data Direction and Output Latch registers are TRISG and LATG. All pins on PORTG are digital only and tolerate voltages up to 5.5V.

PORTG is multiplexed with both AUSART and LCD functions (Table 9-16). When operating as I/O, all PORTG pins have Schmitt Trigger input buffers. The RG1 pin is also configurable for open-drain output when the AUSART is active. Open-drain configuration is selected by setting the U2OD control bit (LATG<7>).

RG4 is multiplexed with LCD segment drives controlled by bits in the LCDSE2 register. The I/O port function is only available when the segments are disabled.

RG3 and RG2 are multiplexed with VLCAP pins for the LCD charge pump, and RG0 is multiplexed with LCDBIAS0 bias voltage input. When these pins are used for LCD bias generation, the I/O and other functions are unavailable.

When enabling peripheral functions, care should be taken in defining TRIS bits for each PORTG pin. Some peripherals override the TRIS bit to make a pin an output, while other peripherals override the TRIS bit to make a pin an input. The user should refer to the corresponding peripheral section for the correct TRIS bit settings. The pin override value is not loaded into the TRIS register. This allows read-modify-write of the TRIS register without concern due to peripheral overrides.

Although the port itself is only five bits wide, the PORTG<7:5> bits are still implemented to control the weak pull-ups on the I/O ports associated with PORTD, PORTE and PORTJ. Setting these bits enables the respective port pull-ups.

Most of the corresponding TRISG and LATG bits are implemented as open-drain control bits for CCP1, CCP2 and SPI (TRISG<7:5>), and the USARTs (LATG<7:6>). Setting these bits configures the output pin for the corresponding peripheral for open-drain operation. LATG<5> is not implemented.

EXAMPLE 9-7: INITIALIZING PORTG

```
CLRF    PORTG    ; Initialize PORTG by
                ; clearing output
                ; data latches
CLRF    LATG     ; Alternate method
                ; to clear output
                ; data latches
MOVLW   04h     ; Value used to
                ; initialize data
                ; direction
MOVWF   TRISG   ; Set RG1:RG0 as outputs
                ; RG2 as input
                ; RG4:RG3 as inputs
```

PIC18F85J90 FAMILY

TABLE 9-16: PORTG FUNCTIONS

Pin Name	Function	TRIS Setting	I/O	I/O Type	Description
RG0/LCDBIAS0	RG0	0	O	DIG	LATG<0> data output.
		1	I	ST	PORTG<0> data input.
	LCDBIAS0	x	I	ANA	LCD module bias voltage input.
RG1/TX2/CK2	RG1	0	O	DIG	LATG<1> data output.
		1	I	ST	PORTG<1> data input.
	TX2	1	O	DIG	Synchronous serial data output (AUSART module); takes priority over port data.
	CK2	1	O	DIG	Synchronous serial data input (AUSART module); user must configure as an input.
		1	I	ST	Synchronous serial clock input (AUSART module).
RG2/RX2/DT2/VLCAP1	RG2	0	O	DIG	LATG<2> data output.
		1	I	ST	PORTG<2> data input.
	RX2	1	I	ST	Asynchronous serial receive data input (AUSART module).
	DT2	1	O	DIG	Synchronous serial data output (AUSART module); takes priority over port data.
		1	I	ST	Synchronous serial data input (AUSART module); user must configure as an input.
	VLCAP1	x	I	ANA	LCD charge pump capacitor input.
RG3/VLCAP2	RG3	0	O	DIG	LATG<3> data output.
		1	I	ST	PORTG<3> data input.
	VLCAP2	x	I	ANA	LCD charge pump capacitor input.
RG4/SEG26	RG4	0	O	DIG	LATG<4> data output.
		1	I	ST	PORTG<4> data input.
	SEG26	x	O	ANA	LCD segment 26 output; disables all other pin functions.

Legend: O = Output, I = Input, ANA = Analog Signal, DIG = Digital Output, ST = Schmitt Trigger Buffer Input, x = Don't care (TRIS bit does not affect port direction or is overridden for this option).

TABLE 9-17: SUMMARY OF REGISTERS ASSOCIATED WITH PORTG

Name	Bit 7	Bit 6	Bit 5	Bit 4	Bit 3	Bit 2	Bit 1	Bit 0	Reset Values on page
PORTG	RDPU	REPU	RJPU ⁽¹⁾	RG4	RG3	RG2	RG1	RG0	54
LATG	U2OD	U1OD	—	LATG4	LATG3	LATG2	LATG1	LATG0	54
TRISG	SPIOD	CCP2OD	CCP1OD	TRISG4	TRISG3	TRISG2	TRISG1	TRISG0	54
LCDSE3	SE31	SE30	SE29	SE28	SE27	SE26	SE25	SE24	53

Legend: — = unimplemented, read as '0'. Shaded cells are not used by PORTG.

Note 1: Unimplemented on 64-pin devices, read as '0'.

9.9 PORTH, LATH and TRISH Registers

Note: PORTH is available only on 80-pin devices.

PORTH is an 8-bit wide, bidirectional I/O port. The corresponding Data Direction and Output Latch registers are TRISH and LATH. All pins are digital only and tolerate voltages up to 5.5V.

All pins on PORTH are implemented with Schmitt Trigger input buffers. Each pin is individually configurable as an input or output.

All PORTH pins are multiplexed with LCD segment drives controlled by the LCDSE5 register. I/O port functions are only available when the segments are disabled.

EXAMPLE 9-8: INITIALIZING PORTH

```
CLRF   PORTH      ; Initialize PORTH by
                  ; clearing output
                  ; data latches
CLRF   LATH        ; Alternate method
                  ; to clear output
                  ; data latches
MOVLW  0Fh        ; Configure PORTH as
MOVWF  ADCON1     ; digital I/O
MOVLW  0CFh       ; Value used to
                  ; initialize data
                  ; direction
MOVWF  TRISH      ; Set RH3:RH0 as inputs
                  ; RH5:RH4 as outputs
                  ; RH7:RH6 as inputs
```

PIC18F85J90 FAMILY

TABLE 9-18: PORTH FUNCTIONS

Pin Name	Function	TRIS Setting	I/O	I/O Type	Description
RH0/SEG47	RH0	0	O	DIG	LATH<0> data output.
		1	I	ST	PORTH<0> data input.
	SEG47	x	O	ANA	LCD segment 47 output; disables all other pin functions.
RH1/SEG46	RH1	0	O	DIG	LATH<1> data output.
		1	I	ST	PORTH<1> data input.
	SEG46	x	O	ANA	LCD segment 46 output; disables all other pin functions.
RH2/SEG45	RH2	0	O	DIG	LATH<2> data output.
		1	I	ST	PORTH<2> data input.
	SEG45	x	O	ANA	LCD segment 45 output; disables all other pin functions.
RH3/SEG44	RH3	0	O	DIG	LATH<3> data output.
		1	I	ST	PORTH<3> data input.
	SEG44	x	O	ANA	LCD segment 44 output; disables all other pin functions.
RH4/SEG40	RH4	0	O	DIG	LATH<4> data output.
		1	I	ST	PORTH<4> data input.
	SEG40	x	O	ANA	LCD segment 40 output; disables all other pin functions.
RH5/SEG41	RH5	0	O	DIG	LATH<5> data output.
		1	I	ST	PORTH<5> data input.
	SEG41	x	O	ANA	LCD segment 41 output; disables all other pin functions.
RH6/SEG42	RH6	0	O	DIG	LATH<6> data output.
		1	I	ST	PORTH<6> data input.
	SEG42	x	O	ANA	LCD segment 42 output; disables all other pin functions.
RH7/SEG43	RH7	0	O	DIG	LATH<7> data output.
		1	I	ST	PORTH<7> data input.
	SEG43	x	O	ANA	LCD segment 43 output; disables all other pin functions.

Legend: O = Output, I = Input, ANA = Analog Signal, DIG = Digital Output, ST = Schmitt Trigger Buffer Input, x = Don't care (TRIS bit does not affect port direction or is overridden for this option).

TABLE 9-19: SUMMARY OF REGISTERS ASSOCIATED WITH PORTH

Name	Bit 7	Bit 6	Bit 5	Bit 4	Bit 3	Bit 2	Bit 1	Bit 0	Reset Values on page
PORTH	RH7	RH6	RH5	RH4	RH3	RH2	RH1	RH0	54
LATH	LATH7	LATH6	LATH5	LATH4	LATH3	LATH2	LATH1	LATH0	54
TRISH	TRISH7	TRISH6	TRISH5	TRISH4	TRISH3	TRISH2	TRISH1	TRISH0	54
LCDSE5	SE47	SE46	SE45	SE44	SE43	SE42	SE41	SE40	53

9.10 PORTJ, TRISJ and LATJ Registers

Note: PORTJ is available only on 80-pin devices.

PORTJ is an 8-bit wide, bidirectional port. The corresponding Data Direction and Output Latch registers are TRISJ and LATJ. All pins on PORTJ are digital only and tolerate voltages up to 5.5V.

All pins on PORTJ are implemented with Schmitt Trigger input buffers. Each pin is individually configurable as an input or output.

Note: These pins are configured as digital inputs on any device Reset.

All PORTJ pins except RJ0 are multiplexed with LCD segment drives controlled by the LCDSE4 register. I/O port functions are only available on these pins when the segments are disabled.

Each of the PORTJ pins has a weak internal pull-up. The pull-ups are provided to keep the inputs at a known state for the external memory interface while powering up. A single control bit can turn off all the pull-ups. This is performed by clearing bit RJPU (PORTG<5>). The weak pull-up is automatically turned off when the port pin is configured as an output. The pull-ups are disabled on any device Reset.

EXAMPLE 9-9: INITIALIZING PORTJ

```
CLRF    PORTJ    ; Initialize PORTJ by
              ; clearing output latches
CLRF    LATJ     ; Alternate method
              ; to clear output latches
MOVLW   0CFh    ; Value used to
              ; initialize data
              ; direction
MOVWF   TRISJ   ; Set RJ3:RJ0 as inputs
              ; RJ5:RJ4 as output
              ; RJ7:RJ6 as inputs
```

PIC18F85J90 FAMILY

TABLE 9-20: PORTJ FUNCTIONS

Pin Name	Function	TRIS Setting	I/O	I/O Type	Description
RJ0	RJ0	0	O	DIG	LATJ<0> data output.
		1	I	ST	PORTJ<0> data input.
RJ1/SEG33	RJ1	0	O	DIG	LATJ<1> data output.
		1	I	ST	PORTJ<1> data input.
	SEG33	x	O	ANA	LCD segment 33 output; disables all other pin functions.
RJ2/SEG34	RJ2	0	O	DIG	LATJ<2> data output.
		1	I	ST	PORTJ<2> data input.
	SEG34	x	O	ANA	LCD segment 34 output; disables all other pin functions.
RJ3/SEG35	RJ3	0	O	DIG	LATJ<3> data output.
		1	I	ST	PORTJ<3> data input.
	SEG35	x	O	ANA	LCD segment 35 output; disables all other pin functions.
RJ4/SEG39	RJ4	0	O	DIG	LATJ<4> data output.
		1	I	ST	PORTJ<4> data input.
	SEG39	x	O	ANA	LCD segment 39 output; disables all other pin functions.
RJ5/SEG38	RJ5	0	O	DIG	LATJ<5> data output.
		1	I	ST	PORTJ<5> data input.
	SEG38	x	O	ANA	LCD segment 38 output; disables all other pin functions.
RJ6/SEG37	RJ6	0	O	DIG	LATJ<6> data output.
		1	I	ST	PORTJ<6> data input.
	SEG37	x	O	ANA	LCD segment 37 output; disables all other pin functions.
RJ7/SEG36	RJ7	0	O	DIG	LATJ<7> data output.
		1	I	ST	PORTJ<7> data input.
	SEG36	x	O	ANA	LCD segment 36 output; disables all other pin functions.

Legend: O = Output, I = Input, ANA = Analog Signal, DIG = Digital Output, ST = Schmitt Trigger Buffer Input, x = Don't care (TRIS bit does not affect port direction or is overridden for this option).

TABLE 9-21: SUMMARY OF REGISTERS ASSOCIATED WITH PORTJ

Name	Bit 7	Bit 6	Bit 5	Bit 4	Bit 3	Bit 2	Bit 1	Bit 0	Reset Values on page
PORTJ	RJ7	RJ6	RJ5	RJ4	RJ3	RJ2	RJ1	RJ0	54
LATJ	LATJ7	LATJ6	LATJ5	LATJ4	LATJ3	LATJ2	LATJ1	LATJ0	54
TRISJ	TRISJ7	TRISJ6	TRISJ5	TRISJ4	TRISJ3	TRISJ2	TRISJ1	TRISJ0	54
PORTG	RDPJ	REPU	RJPU ⁽¹⁾	RG4	RG3	RG2	RG1	RG0	54
LCDSE4	SE39	SE38	SE37	SE36	SE35	SE34	SE33	SE32	53

Legend: Shaded cells are not used by PORTJ.

Note 1: Unimplemented on 64-pin devices, read as '0'.

PIC18F85J90 FAMILY

10.0 TIMER0 MODULE

The Timer0 module incorporates the following features:

- Software selectable operation as a timer or counter in both 8-bit or 16-bit modes
- Readable and writable registers
- Dedicated 8-bit, software programmable prescaler
- Selectable clock source (internal or external)
- Edge select for external clock
- Interrupt-on-overflow

The T0CON register (Register 10-1) controls all aspects of the module's operation, including the prescale selection; it is both readable and writable.

A simplified block diagram of the Timer0 module in 8-bit mode is shown in Figure 10-1. Figure 10-2 shows a simplified block diagram of the Timer0 module in 16-bit mode.

REGISTER 10-1: T0CON: TIMER0 CONTROL REGISTER

R/W-1	R/W-1	R/W-1	R/W-1	R/W-1	R/W-1	R/W-1	R/W-1
TMR0ON	T08BIT	T0CS	T0SE	PSA	T0PS2	T0PS1	T0PS0
bit 7							bit 0

Legend:

R = Readable bit

W = Writable bit

U = Unimplemented bit, read as '0'

-n = Value at POR

'1' = Bit is set

'0' = Bit is cleared

x = Bit is unknown

bit 7 **TMR0ON:** Timer0 On/Off Control bit

1 = Enables Timer0

0 = Stops Timer0

bit 6 **T08BIT:** Timer0 8-Bit/16-Bit Control bit

1 = Timer0 is configured as an 8-bit timer/counter

0 = Timer0 is configured as a 16-bit timer/counter

bit 5 **T0CS:** Timer0 Clock Source Select bit

1 = Transition on T0CKI pin

0 = Internal instruction cycle clock (CLKO)

bit 4 **T0SE:** Timer0 Source Edge Select bit

1 = Increment on high-to-low transition on T0CKI pin

0 = Increment on low-to-high transition on T0CKI pin

bit 3 **PSA:** Timer0 Prescaler Assignment bit

1 = Timer0 prescaler is not assigned. Timer0 clock input bypasses prescaler.

0 = Timer0 prescaler is assigned. Timer0 clock input comes from prescaler output.

bit 2-0 **T0PS2:T0PS0:** Timer0 Prescaler Select bits

111 = 1:256 Prescale value

110 = 1:128 Prescale value

101 = 1:64 Prescale value

100 = 1:32 Prescale value

011 = 1:16 Prescale value

010 = 1:8 Prescale value

001 = 1:4 Prescale value

000 = 1:2 Prescale value

PIC18F85J90 FAMILY

10.1 Timer0 Operation

Timer0 can operate as either a timer or a counter. The mode is selected with the T0CS bit (T0CON<5>). In Timer mode (T0CS = 0), the module increments on every clock by default unless a different prescaler value is selected (see **Section 10.3 “Prescaler”**). If the TMR0 register is written to, the increment is inhibited for the following two instruction cycles. The user can work around this by writing an adjusted value to the TMR0 register.

The Counter mode is selected by setting the T0CS bit (= 1). In this mode, Timer0 increments either on every rising or falling edge of pin RA4/T0CKI. The incrementing edge is determined by the Timer0 Source Edge Select bit, T0SE (T0CON<4>); clearing this bit selects the rising edge. Restrictions on the external clock input are discussed below.

An external clock source can be used to drive Timer0, however, it must meet certain requirements to ensure that the external clock can be synchronized with the

internal phase clock (Tosc). There is a delay between synchronization and the onset of incrementing the timer/counter.

10.2 Timer0 Reads and Writes in 16-Bit Mode

TMR0H is not the actual high byte of Timer0 in 16-bit mode. It is actually a buffered version of the real high byte of Timer0, which is not directly readable nor writable (refer to Figure 10-2). TMR0H is updated with the contents of the high byte of Timer0 during a read of TMR0L. This provides the ability to read all 16 bits of Timer0 without having to verify that the read of the high and low byte were valid, due to a rollover between successive reads of the high and low byte.

Similarly, a write to the high byte of Timer0 must also take place through the TMR0H Buffer register. The high byte is updated with the contents of TMR0H when a write occurs to TMR0L. This allows all 16 bits of Timer0 to be updated at once.

FIGURE 10-1: TIMER0 BLOCK DIAGRAM (8-BIT MODE)

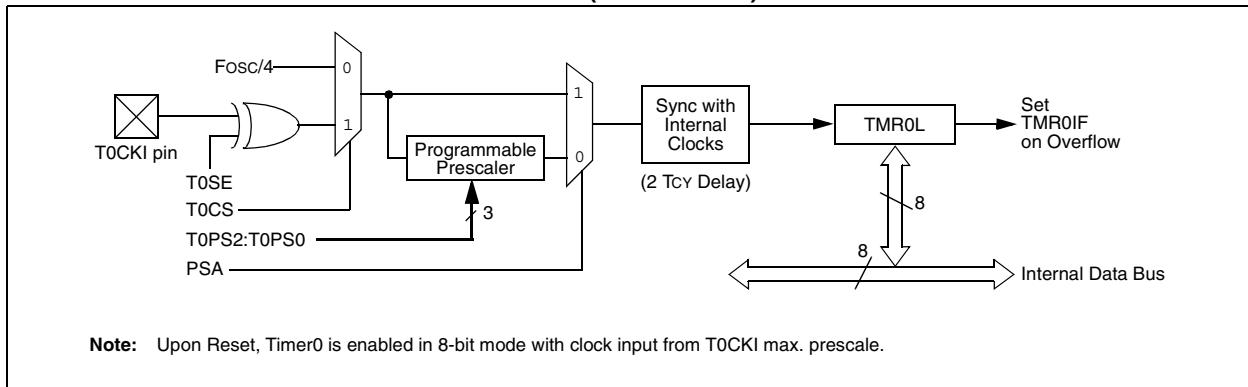
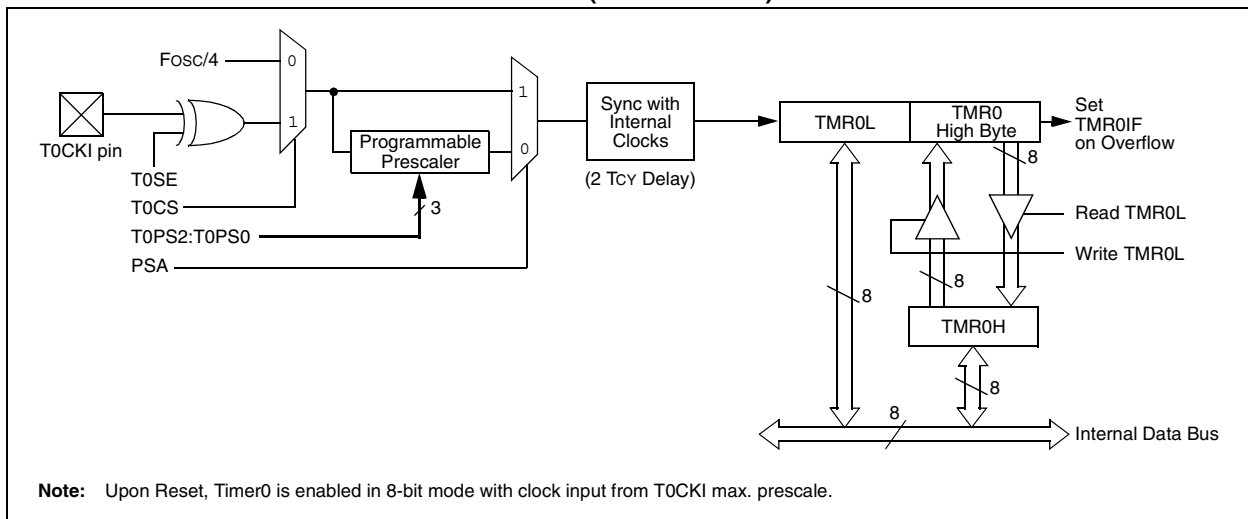

FIGURE 10-2: TIMER0 BLOCK DIAGRAM (16-BIT MODE)



PIC18F85J90 FAMILY

10.3 Prescaler

An 8-bit counter is available as a prescaler for the Timer0 module. The prescaler is not directly readable or writable. Its value is set by the PSA and T0PS2:T0PS0 bits (T0CON<3:0>) which determine the prescaler assignment and prescale ratio.

Clearing the PSA bit assigns the prescaler to the Timer0 module. When it is assigned, prescale values from 1:2 through 1:256, in power-of-2 increments, are selectable.

When assigned to the Timer0 module, all instructions writing to the TMR0 register (e.g., `CLRF TMR0`, `MOVWF TMR0`, `BSF TMR0`, etc.) clear the prescaler count.

Note: Writing to TMR0 when the prescaler is assigned to Timer0 will clear the prescaler count but will not change the prescaler assignment.

10.3.1 SWITCHING PRESCALER ASSIGNMENT

The prescaler assignment is fully under software control and can be changed “on-the-fly” during program execution.

10.4 Timer0 Interrupt

The TMR0 interrupt is generated when the TMR0 register overflows from FFh to 00h in 8-bit mode, or from FFFFh to 0000h in 16-bit mode. This overflow sets the TMR0IF flag bit. The interrupt can be masked by clearing the TMR0IE bit (INTCON<5>). Before re-enabling the interrupt, the TMR0IF bit must be cleared in software by the Interrupt Service Routine.

Since Timer0 is shut down in Sleep mode, the TMR0 interrupt cannot awaken the processor from Sleep.

TABLE 10-1: REGISTERS ASSOCIATED WITH TIMER0

Name	Bit 7	Bit 6	Bit 5	Bit 4	Bit 3	Bit 2	Bit 1	Bit 0	Reset Values on page
TMR0L	Timer0 Register Low Byte								52
TMR0H	Timer0 Register High Byte								52
INTCON	GIE/GIEH	PEIE/GIEL	TMR0IE	INT0IE	RBIE	TMR0IF	INT0IF	RBIF	51
T0CON	TMR0ON	T08BIT	T0CS	T0SE	PSA	T0PS2	T0PS1	T0PS0	52
TRISA	TRISA7 ⁽¹⁾	TRISA6 ⁽¹⁾	TRISA5	TRISA4	TRISA3	TRISA2	TRISA1	TRISA0	54

Legend: — = unimplemented, read as ‘0’. Shaded cells are not used by Timer0.

Note 1: RA6/RA7 and their associated latch and direction bits are configured as port pins only when the internal oscillator is selected as the default clock source (FOSC2 Configuration bit = 0); otherwise, they are disabled and these bits read as ‘0’.

PIC18F85J90 FAMILY

NOTES:

PIC18F85J90 FAMILY

11.0 TIMER1 MODULE

The Timer1 timer/counter module incorporates these features:

- Software selectable operation as a 16-bit timer or counter
- Readable and writable 8-bit registers (TMR1H and TMR1L)
- Selectable clock source (internal or external) with device clock or Timer1 oscillator internal options
- Interrupt on overflow
- Reset on CCP Special Event Trigger
- Device clock status flag (T1RUN)

A simplified block diagram of the Timer1 module is shown in Figure 11-1. A block diagram of the module's operation in Read/Write mode is shown in Figure 11-2.

The module incorporates its own low-power oscillator to provide an additional clocking option. The Timer1 oscillator can also be used as a low-power clock source for the microcontroller in power-managed operation.

Timer1 can also be used to provide Real-Time Clock (RTC) functionality to applications with only a minimal addition of external components and code overhead.

Timer1 is controlled through the T1CON Control register (Register 11-1). It also contains the Timer1 Oscillator Enable bit (T1OSCEN). Timer1 can be enabled or disabled by setting or clearing control bit, TMR1ON (T1CON<0>).

REGISTER 11-1: T1CON: TIMER1 CONTROL REGISTER

R/W-0	R-0	R/W-0	R/W-0	R/W-0	R/W-0	R/W-0	R/W-0
RD16	T1RUN	T1CKPS1	T1CKPS0	T1OSCEN	T1SYNC	TMR1CS	TMR1ON
bit 7							bit 0

Legend:

R = Readable bit	W = Writable bit	U = Unimplemented bit, read as '0'
-n = Value at POR	'1' = Bit is set	'0' = Bit is cleared
		x = Bit is unknown

bit 7	RD16: 16-Bit Read/Write Mode Enable bit 1 = Enables register read/write of Timer1 in one 16-bit operation 0 = Enables register read/write of Timer1 in two 8-bit operations
bit 6	T1RUN: Timer1 System Clock Status bit 1 = Device clock is derived from Timer1 oscillator 0 = Device clock is derived from another source
bit 5-4	T1CKPS1:T1CKPS0: Timer1 Input Clock Prescale Select bits 11 = 1:8 Prescale value 10 = 1:4 Prescale value 01 = 1:2 Prescale value 00 = 1:1 Prescale value
bit 3	T1OSCEN: Timer1 Oscillator Enable bit 1 = Timer1 oscillator is enabled 0 = Timer1 oscillator is shut off The oscillator inverter and feedback resistor are turned off to eliminate power drain.
bit 2	T1SYNC: Timer1 External Clock Input Synchronization Select bit <u>When TMR1CS = 1:</u> 1 = Do not synchronize external clock input 0 = Synchronize external clock input <u>When TMR1CS = 0:</u> This bit is ignored. Timer1 uses the internal clock when TMR1CS = 0.
bit 1	TMR1CS: Timer1 Clock Source Select bit 1 = External clock from pin RC0/T1OSO/T13CKI (on the rising edge) 0 = Internal clock (FOSC/4)
bit 0	TMR1ON: Timer1 On bit 1 = Enables Timer1 0 = Stops Timer1

PIC18F85J90 FAMILY

11.1 Timer1 Operation

Timer1 can operate in one of these modes:

- Timer
- Synchronous Counter
- Asynchronous Counter

The operating mode is determined by the clock select bit, TMR1CS (T1CON<1>). When TMR1CS is cleared (= 0), Timer1 increments on every internal instruction

cycle ($F_{OSC}/4$). When the bit is set, Timer1 increments on every rising edge of the Timer1 external clock input or the Timer1 oscillator, if enabled.

When Timer1 is enabled, the RC1/T1OSI and RC0/T1OSO/T13CKI pins become inputs. This means the values of TRISC<1:0> are ignored and the pins are read as '0'.

FIGURE 11-1: TIMER1 BLOCK DIAGRAM (8-BIT MODE)

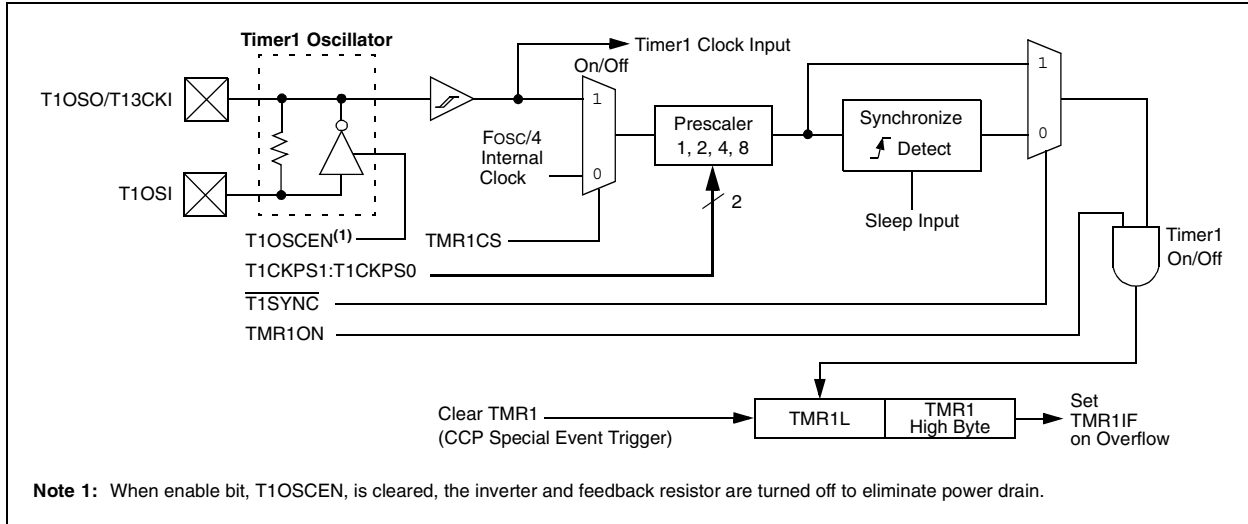
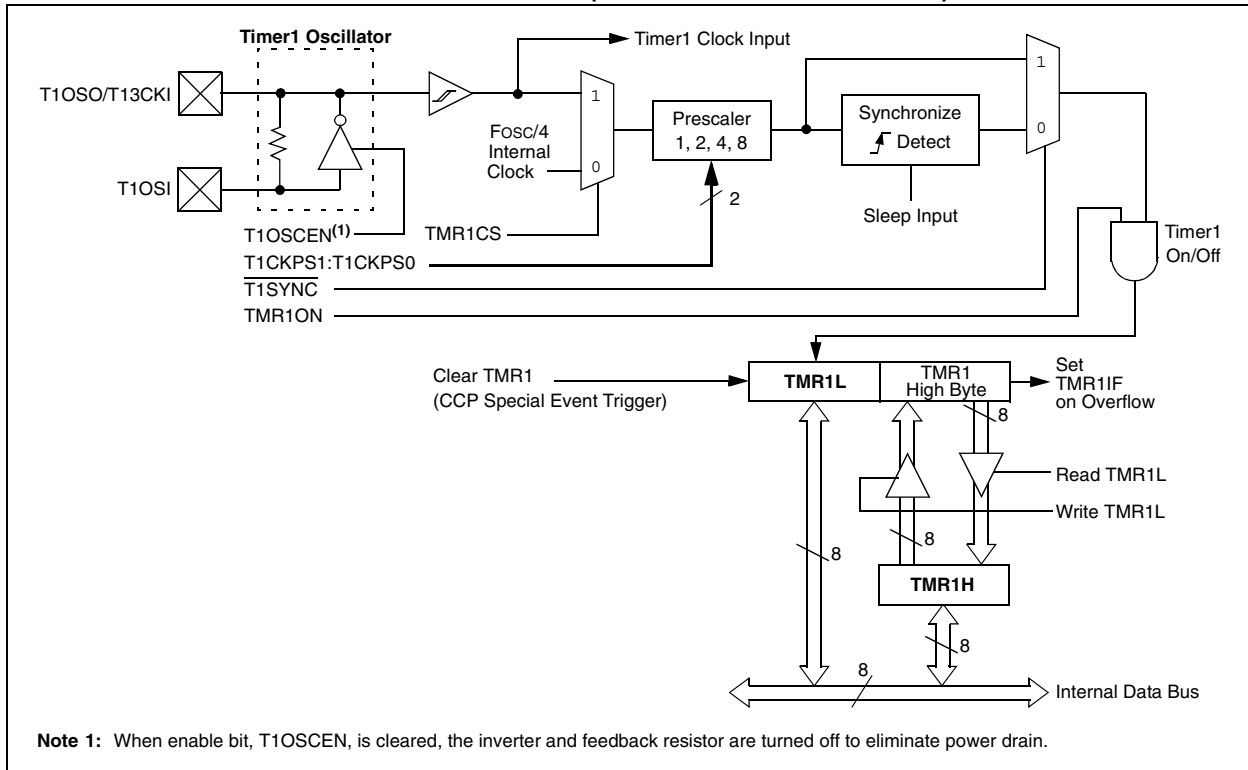

FIGURE 11-2: TIMER1 BLOCK DIAGRAM (16-BIT READ/WRITE MODE)



PIC18F85J90 FAMILY

11.2 Timer1 16-Bit Read/Write Mode

Timer1 can be configured for 16-bit reads and writes (see Figure 11-2). When the RD16 control bit (T1CON<7>) is set, the address for TMR1H is mapped to a buffer register for the high byte of Timer1. A read from TMR1L will load the contents of the high byte of Timer1 into the Timer1 High Byte Buffer register. This provides the user with the ability to accurately read all 16 bits of Timer1 without having to determine whether a read of the high byte, followed by a read of the low byte, has become invalid due to a rollover between reads.

A write to the high byte of Timer1 must also take place through the TMR1H Buffer register. The Timer1 high byte is updated with the contents of TMR1H when a write occurs to TMR1L. This allows a user to write all 16 bits to both the high and low bytes of Timer1 at once.

The high byte of Timer1 is not directly readable or writable in this mode. All reads and writes must take place through the Timer1 High Byte Buffer register. Writes to TMR1H do not clear the Timer1 prescaler. The prescaler is only cleared on writes to TMR1L.

11.3 Timer1 Oscillator

An on-chip crystal oscillator circuit is incorporated between pins T1OSI (input) and T1OSO (amplifier output). It is enabled by setting the Timer1 Oscillator Enable bit, T1OSCEN (T1CON<3>). The oscillator is a low-power circuit rated for 32 kHz crystals. It will continue to run during all power-managed modes. The circuit for a typical LP oscillator is shown in Figure 11-3. Table 11-1 shows the capacitor selection for the Timer1 oscillator.

The user must provide a software time delay to ensure proper start-up of the Timer1 oscillator.

FIGURE 11-3: EXTERNAL COMPONENTS FOR THE TIMER1 LP OSCILLATOR

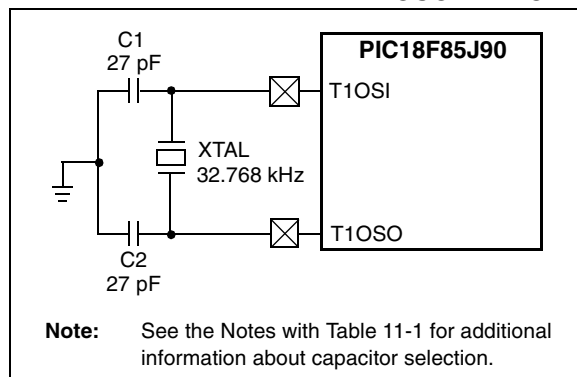

TABLE 11-1: CAPACITOR SELECTION FOR THE TIMER1 OSCILLATOR^(2,3,4)

Oscillator Type	Freq.	C1	C2
LP	32.768 kHz	27 pF ⁽¹⁾	27 pF ⁽¹⁾

Note 1: Microchip suggests these values as a starting point in validating the oscillator circuit.

2: Higher capacitance increases the stability of the oscillator but also increases the start-up time.

3: Since each resonator/crystal has its own characteristics, the user should consult the resonator/crystal manufacturer for appropriate values of external components.

4: Capacitor values are for design guidance only.

11.3.1 USING TIMER1 AS A CLOCK SOURCE

The Timer1 oscillator is also available as a clock source in power-managed modes. By setting the System Clock Select bits, SCS1:SCS0 (OSCCON<1:0>), to '01', the device switches to SEC_RUN mode; both the CPU and peripherals are clocked from the Timer1 oscillator. If the IDLEN bit (OSCCON<7>) is cleared and a SLEEP instruction is executed, the device enters SEC_IDLE mode. Additional details are available in **Section 3.0 "Power-Managed Modes"**.

Whenever the Timer1 oscillator is providing the clock source, the Timer1 system clock status flag, T1RUN (T1CON<6>), is set. This can be used to determine the controller's current clocking mode. It can also indicate the clock source being currently used by the Fail-Safe Clock Monitor. If the Clock Monitor is enabled and the Timer1 oscillator fails while providing the clock, polling the T1RUN bit will indicate whether the clock is being provided by the Timer1 oscillator or another source.

PIC18F85J90 FAMILY

11.3.2 TIMER1 OSCILLATOR LAYOUT CONSIDERATIONS

The Timer1 oscillator circuit draws very little power during operation. Due to the low-power nature of the oscillator, it may also be sensitive to rapidly changing signals in close proximity.

The oscillator circuit, shown in Figure 11-3, should be located as close as possible to the microcontroller. There should be no circuits passing within the oscillator circuit boundaries other than VSS or VDD.

If a high-speed circuit must be located near the oscillator (such as the CCP1 pin in Output Compare or PWM mode, or the primary oscillator using the OSC2 pin), a grounded guard ring around the oscillator circuit, as shown in Figure 11-4, may be helpful when used on a single-sided PCB or in addition to a ground plane.

FIGURE 11-4: OSCILLATOR CIRCUIT WITH GROUNDED GUARD RING

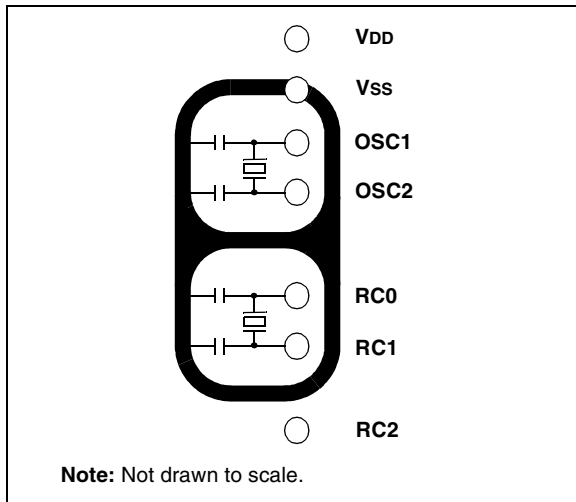

11.4 Timer1 Interrupt

The TMR1 register pair (TMR1H:TMR1L) increments from 0000h to FFFFh and rolls over to 0000h. The Timer1 interrupt, if enabled, is generated on overflow which is latched in interrupt flag bit, TMR1IF (PIR1<0>). This interrupt can be enabled or disabled by setting or clearing the Timer1 Interrupt Enable bit, TMR1IE (PIE1<0>).

11.5 Resetting Timer1 Using the CCP Special Event Trigger

If CCP1 or CCP2 is configured to use Timer1 and to generate a Special Event Trigger in Compare mode (CCPxM3:CCPxM0 = 1011), this signal will reset Timer3. The trigger from CCP2 will also start an A/D conversion if the A/D module is enabled (see **Section 14.3.4 “Special Event Trigger”** for more information).

The module must be configured as either a timer or a synchronous counter to take advantage of this feature. When used this way, the CCPRxH:CCPRxL register pair effectively becomes a period register for Timer1.

If Timer1 is running in Asynchronous Counter mode, this Reset operation may not work.

In the event that a write to Timer1 coincides with a Special Event Trigger, the write operation will take precedence.

Note: The Special Event Triggers from the CCPx module will not set the TMR1IF interrupt flag bit (PIR1<0>).

11.6 Using Timer1 as a Real-Time Clock

Adding an external LP oscillator to Timer1 (such as the one described in **Section 11.3 “Timer1 Oscillator”** above) gives users the option to include RTC functionality to their applications. This is accomplished with an inexpensive watch crystal to provide an accurate time base and several lines of application code to calculate the time. When operating in Sleep mode and using a battery or supercapacitor as a power source, it can completely eliminate the need for a separate RTC device and battery backup.

The application code routine, *RTCISR*, shown in Example 11-1, demonstrates a simple method to increment a counter at one-second intervals using an Interrupt Service Routine. Incrementing the TMR1 register pair to overflow triggers the interrupt and calls the routine which increments the seconds counter by one. Additional counters for minutes and hours are incremented as the previous counter overflows.

Since the register pair is 16 bits wide, counting up to overflow the register directly from a 32.768 kHz clock would take 2 seconds. To force the overflow at the required one-second intervals, it is necessary to preload it. The simplest method is to set the MSb of TMR1H with a BSF instruction. Note that the TMR1L register is never preloaded or altered; doing so may introduce cumulative error over many cycles.

For this method to be accurate, Timer1 must operate in Asynchronous mode and the Timer1 overflow interrupt must be enabled (PIE1<0> = 1) as shown in the routine, *RTCinit*. The Timer1 oscillator must also be enabled and running at all times.

PIC18F85J90 FAMILY

EXAMPLE 11-1: IMPLEMENTING A REAL-TIME CLOCK USING A TIMER1 INTERRUPT SERVICE

```

RTCinit
    MOVLW    80h           ; Preload TMR1 register pair
    MOVWF   TMR1H        ; for 1 second overflow
    CLRF    TMR1L
    MOVLW   b'00001111'  ; Configure for external clock,
    MOVWF   T1CON        ; Asynchronous operation, external oscillator
    CLRF    secs        ; Initialize timekeeping registers
    CLRF    mins
    MOVLW   .12
    MOVWF   hours
    BSF     PIE1, TMR1IE ; Enable Timer1 interrupt
    RETURN

RTCisr
    BSF     TMR1H, 7     ; Preload for 1 sec overflow
    BCF     PIR1, TMR1IF ; Clear interrupt flag
    INCF    secs, F      ; Increment seconds
    MOVLW   .59         ; 60 seconds elapsed?
    CPFSGT secs
    RETURN            ; No, done
    CLRF    secs        ; Clear seconds
    INCF    mins, F     ; Increment minutes
    MOVLW   .59         ; 60 minutes elapsed?
    CPFSGT mins
    RETURN            ; No, done
    CLRF    mins        ; clear minutes
    INCF    hours, F    ; Increment hours
    MOVLW   .23         ; 24 hours elapsed?
    CPFSGT hours
    RETURN            ; No, done
    CLRF    hours        ; Reset hours
    RETURN            ; Done
    
```

TABLE 11-2: REGISTERS ASSOCIATED WITH TIMER1 AS A TIMER/COUNTER

Name	Bit 7	Bit 6	Bit 5	Bit 4	Bit 3	Bit 2	Bit 1	Bit 0	Reset Values on page
INTCON	GIE/GIEH	PEIE/GIEL	TMR0IE	INT0IE	RBIE	TMR0IF	INT0IF	RBIF	51
PIR1	—	ADIF	RC1IF	TX1IF	SSPIF	—	TMR2IF	TMR1IF	54
PIE1	—	ADIE	RC1IE	TX1IE	SSPIE	—	TMR2IE	TMR1IE	54
IPR1	—	ADIP	RC1IP	TX1IP	SSPIP	—	TMR2IP	TMR1IP	54
TMR1L	Timer1 Register Low Byte								52
TMR1H	Timer1 Register High Byte								52
T1CON	RD16	T1RUN	T1CKPS1	T1CKPS0	T1OSCEN	T1SYNC	TMR1CS	TMR1ON	52

Legend: Shaded cells are not used by the Timer1 module.

PIC18F85J90 FAMILY

NOTES:

PIC18F85J90 FAMILY

12.0 TIMER2 MODULE

The Timer2 module incorporates the following features:

- 8-bit Timer and Period registers (TMR2 and PR2, respectively)
- Readable and writable (both registers)
- Software programmable prescaler (1:1, 1:4 and 1:16)
- Software programmable postscaler (1:1 through 1:16)
- Interrupt on TMR2 to PR2 match
- Optional use as the shift clock for the MSSP module

The module is controlled through the T2CON register (Register 12-1) which enables or disables the timer and configures the prescaler and postscaler. Timer2 can be shut off by clearing control bit, TMR2ON (T2CON<2>), to minimize power consumption.

A simplified block diagram of the module is shown in Figure 12-1.

12.1 Timer2 Operation

In normal operation, TMR2 is incremented from 00h on each clock ($F_{OSC}/4$). A 4-bit counter/prescaler on the clock input gives direct input, divide-by-4 and divide-by-16 prescale options. These are selected by the prescaler control bits, T2CKPS1:T2CKPS0 (T2CON<1:0>). The value of TMR2 is compared to that of the Period register, PR2, on each clock cycle. When the two values match, the comparator generates a match signal as the timer output. This signal also resets the value of TMR2 to 00h on the next cycle and drives the output counter/postscaler (see **Section 12.2 “Timer2 Interrupt”**).

The TMR2 and PR2 registers are both directly readable and writable. The TMR2 register is cleared on any device Reset, while the PR2 register initializes at FFh. Both the prescaler and postscaler counters are cleared on the following events:

- a write to the TMR2 register
- a write to the T2CON register
- any device Reset (Power-on Reset, \overline{MCLR} Reset, Watchdog Timer Reset or Brown-out Reset)

TMR2 is not cleared when T2CON is written.

REGISTER 12-1: T2CON: TIMER2 CONTROL REGISTER

U-0	R/W-0	R/W-0	R/W-0	R/W-0	R/W-0	R/W-0	R/W-0
—	T2OUTPS3	T2OUTPS2	T2OUTPS1	T2OUTPS0	TMR2ON	T2CKPS1	T2CKPS0
bit 7							bit 0

Legend:

R = Readable bit	W = Writable bit	U = Unimplemented bit, read as '0'
-n = Value at POR	'1' = Bit is set	'0' = Bit is cleared
		x = Bit is unknown

bit 7 **Unimplemented:** Read as '0'

bit 6-3 **T2OUTPS3:T2OUTPS0:** Timer2 Output Postscale Select bits
 0000 = 1:1 Postscale
 0001 = 1:2 Postscale
 •
 •
 •
 1111 = 1:16 Postscale

bit 2 **TMR2ON:** Timer2 On bit
 1 = Timer2 is on
 0 = Timer2 is off

bit 1-0 **T2CKPS1:T2CKPS0:** Timer2 Clock Prescale Select bits
 00 = Prescaler is 1
 01 = Prescaler is 4
 1x = Prescaler is 16

PIC18F85J90 FAMILY

12.2 Timer2 Interrupt

Timer2 can also generate an optional device interrupt. The Timer2 output signal (TMR2 to PR2 match) provides the input for the 4-bit output counter/postscaler. This counter generates the TMR2 match interrupt flag which is latched in TMR2IF (PIR1<1>). The interrupt is enabled by setting the TMR2 Match Interrupt Enable bit, TMR2IE (PIE1<1>).

A range of 16 postscale options (from 1:1 through 1:16 inclusive) can be selected with the postscaler control bits, T2OUTPS3:T2OUTPS0 (T2CON<6:3>).

12.3 Timer2 Output

The unscaled output of TMR2 is available primarily to the CCP modules, where it is used as a time base for operations in PWM mode.

Timer2 can be optionally used as the shift clock source for the MSSP module operating in SPI mode. Additional information is provided in **Section 16.0 “Master Synchronous Serial Port (MSSP) Module”**.

FIGURE 12-1: TIMER2 BLOCK DIAGRAM

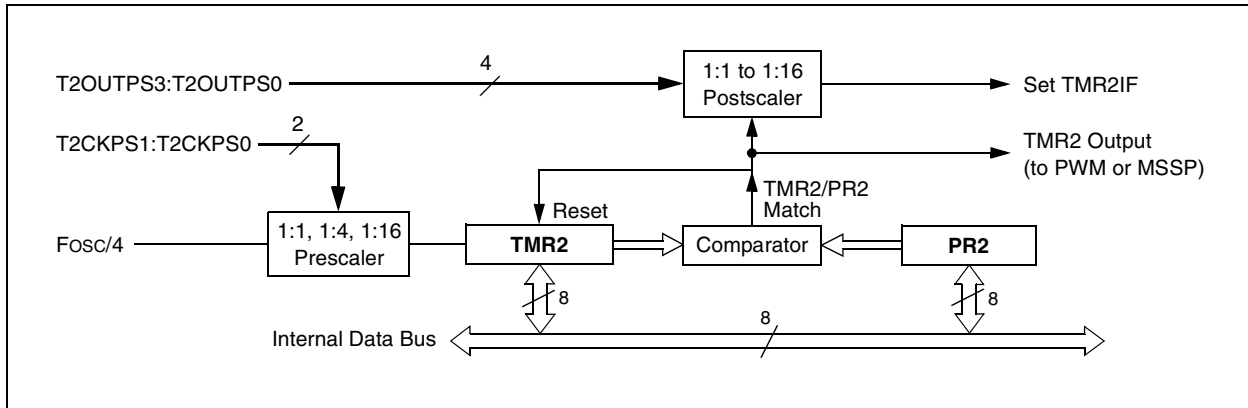

TABLE 12-1: REGISTERS ASSOCIATED WITH TIMER2 AS A TIMER/COUNTER

Name	Bit 7	Bit 6	Bit 5	Bit 4	Bit 3	Bit 2	Bit 1	Bit 0	Reset Values on page
INTCON	GIE/GIEH	PEIE/GIEL	TMR0IE	INT0IE	RBIE	TMR0IF	INT0IF	RBIF	51
PIR1	—	ADIF	RC1IF	TX1IF	SSPIF	—	TMR2IF	TMR1IF	54
PIE1	—	ADIE	RC1IE	TX1IE	SSPIE	—	TMR2IE	TMR1IE	54
IPR1	—	ADIP	RC1IP	TX1IP	SSPIP	—	TMR2IP	TMR1IP	54
TMR2	Timer2 Register								52
T2CON	—	T2OUTPS3	T2OUTPS2	T2OUTPS1	T2OUTPS0	TMR2ON	T2CKPS1	T2CKPS0	52
PR2	Timer2 Period Register								52

Legend: — = unimplemented, read as '0'. Shaded cells are not used by the Timer2 module.

PIC18F85J90 FAMILY

13.0 TIMER3 MODULE

The Timer3 timer/counter module incorporates these features:

- Software selectable operation as a 16-bit timer or counter
- Readable and writable 8-bit registers (TMR3H and TMR3L)
- Selectable clock source (internal or external) with device clock or Timer1 oscillator internal options
- Interrupt on overflow
- Module Reset on CCP Special Event Trigger

A simplified block diagram of the Timer3 module is shown in Figure 13-1. A block diagram of the module's operation in Read/Write mode is shown in Figure 13-2.

The Timer3 module is controlled through the T3CON register (Register 13-1). It also selects the clock source options for the CCP modules. See **Section 14.2.2 "Timer1/Timer3 Mode Selection"** for more information.

REGISTER 13-1: T3CON: TIMER3 CONTROL REGISTER

R/W-0	R/W-0	R/W-0	R/W-0	R/W-0	R/W-0	R/W-0	R/W-0
RD16	T3CCP2	T3CKPS1	T3CKPS0	T3CCP1	$\overline{T3SYNC}$	TMR3CS	TMR3ON
bit 7							bit 0

Legend:

R = Readable bit	W = Writable bit	U = Unimplemented bit, read as '0'
-n = Value at POR	'1' = Bit is set	'0' = Bit is cleared
		x = Bit is unknown

- bit 7 **RD16:** 16-Bit Read/Write Mode Enable bit
 1 = Enables register read/write of Timer3 in one 16-bit operation
 0 = Enables register read/write of Timer3 in two 8-bit operations
- bit 6,3 **T3CCP2:T3CCP1:** Timer3 and Timer1 to CCPx Enable bits
 1x = Timer3 is the capture/compare clock source for the CCP modules
 01 = Timer3 is the capture/compare clock source for CCP2;
 Timer1 is the capture/compare clock source for CCP1
 00 = Timer1 is the capture/compare clock source for the CCP modules
- bit 5-4 **T3CKPS1:T3CKPS0:** Timer3 Input Clock Prescale Select bits
 11 = 1:8 Prescale value
 10 = 1:4 Prescale value
 01 = 1:2 Prescale value
 00 = 1:1 Prescale value
- bit 2 **T3SYNC:** Timer3 External Clock Input Synchronization Control bit
 (Not usable if the device clock comes from Timer1/Timer3.)
When TMR3CS = 1:
 1 = Do not synchronize external clock input
 0 = Synchronize external clock input
When TMR3CS = 0:
 This bit is ignored. Timer3 uses the internal clock when TMR3CS = 0.
- bit 1 **TMR3CS:** Timer3 Clock Source Select bit
 1 = External clock input from Timer1 oscillator or T13CKI (on the rising edge after the first falling edge)
 0 = Internal clock (FOSC/4)
- bit 0 **TMR3ON:** Timer3 On bit
 1 = Enables Timer3
 0 = Stops Timer3

PIC18F85J90 FAMILY

13.1 Timer3 Operation

Timer3 can operate in one of three modes:

- Timer
- Synchronous Counter
- Asynchronous Counter

The operating mode is determined by the clock select bit, TMR3CS (T3CON<1>). When TMR3CS is cleared (= 0), Timer3 increments on every internal instruction cycle ($F_{osc}/4$). When the bit is set, Timer3 increments on every rising edge of the Timer1 external clock input or the Timer1 oscillator, if enabled.

As with Timer1, the RC1/T1OSI and RC0/T1OSO/T13CKI pins become inputs when the Timer1 oscillator is enabled. This means the values of TRISC<1:0> are ignored and the pins are read as '0'.

FIGURE 13-1: TIMER3 BLOCK DIAGRAM (8-BIT MODE)

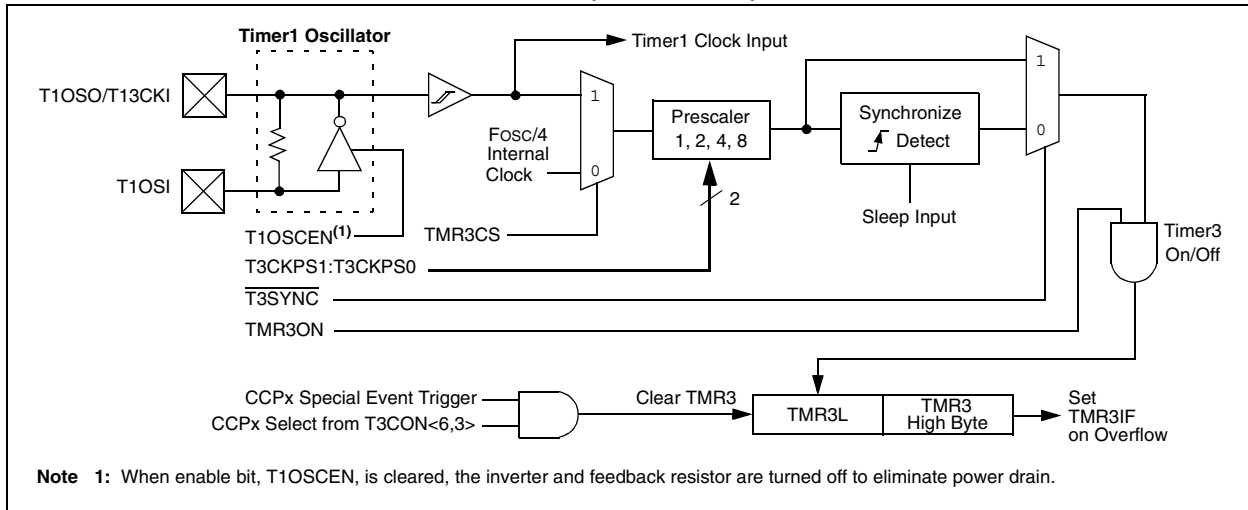
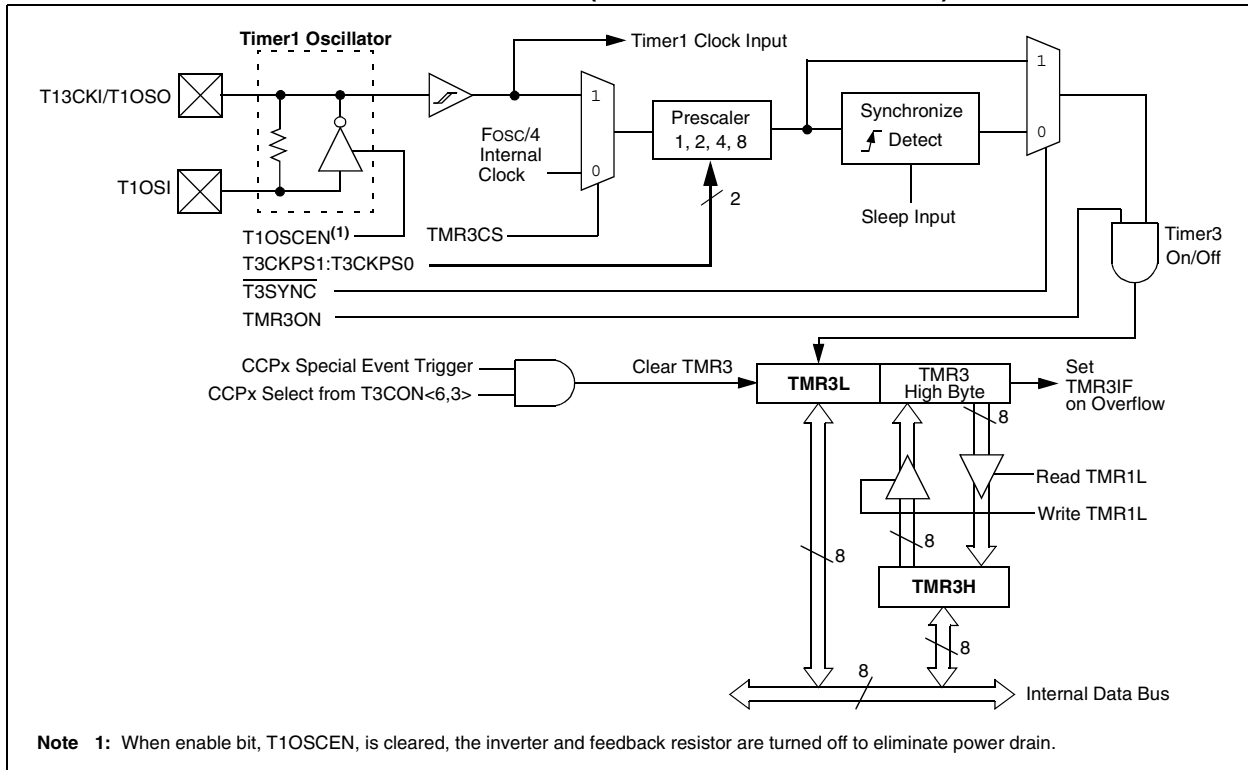

FIGURE 13-2: TIMER3 BLOCK DIAGRAM (16-BIT READ/WRITE MODE)



13.2 Timer3 16-Bit Read/Write Mode

Timer3 can be configured for 16-bit reads and writes (see Figure 13-2). When the RD16 control bit (T3CON<7>) is set, the address for TMR3H is mapped to a buffer register for the high byte of Timer3. A read from TMR3L will load the contents of the high byte of Timer3 into the Timer3 High Byte Buffer register. This provides the user with the ability to accurately read all 16 bits of Timer1 without having to determine whether a read of the high byte, followed by a read of the low byte, has become invalid due to a rollover between reads.

A write to the high byte of Timer3 must also take place through the TMR3H Buffer register. The Timer3 high byte is updated with the contents of TMR3H when a write occurs to TMR3L. This allows a user to write all 16 bits to both the high and low bytes of Timer3 at once.

The high byte of Timer3 is not directly readable or writable in this mode. All reads and writes must take place through the Timer3 High Byte Buffer register.

Writes to TMR3H do not clear the Timer3 prescaler. The prescaler is only cleared on writes to TMR3L.

13.3 Using the Timer1 Oscillator as the Timer3 Clock Source

The Timer1 internal oscillator may be used as the clock source for Timer3. The Timer1 oscillator is enabled by setting the T1OSCEN (T1CON<3>) bit. To use it as the Timer3 clock source, the TMR3CS bit must also be set. As previously noted, this also configures Timer3 to increment on every rising edge of the oscillator source.

The Timer1 oscillator is described in **Section 11.0 “Timer1 Module”**.

13.4 Timer3 Interrupt

The TMR3 register pair (TMR3H:TMR3L) increments from 0000h to FFFFh and overflows to 0000h. The Timer3 interrupt, if enabled, is generated on overflow and is latched in interrupt flag bit, TMR3IF (PIR2<1>). This interrupt can be enabled or disabled by setting or clearing the Timer3 Interrupt Enable bit, TMR3IE (PIE2<1>).

13.5 Resetting Timer3 Using the CCP Special Event Trigger

If CCP1 or CCP2 is configured to use Timer3 and to generate a Special Event Trigger in Compare mode (CCPxM3:CCPxM0 = 1011), this signal will reset Timer3. The trigger from CCP2 will also start an A/D conversion if the A/D module is enabled (see **Section 14.3.4 “Special Event Trigger”** for more information).

The module must be configured as either a timer or synchronous counter to take advantage of this feature. When used this way, the CCPxH:CCPxL register pair effectively becomes a period register for Timer3.

If Timer3 is running in Asynchronous Counter mode, the Reset operation may not work.

In the event that a write to Timer3 coincides with a Special Event Trigger from a CCP module, the write will take precedence.

Note: The Special Event Triggers from the CCPx module will not set the TMR3IF interrupt flag bit (PIR2<1>).

TABLE 13-1: REGISTERS ASSOCIATED WITH TIMER3 AS A TIMER/COUNTER

Name	Bit 7	Bit 6	Bit 5	Bit 4	Bit 3	Bit 2	Bit 1	Bit 0	Reset Values on page
INTCON	GIE/GIEH	PEIE/GIEL	TMR0IE	INT0IE	RBIE	TMR0IF	INT0IF	RBIF	51
PIR2	OSCFIF	CMIF	—	—	BCLIF	LVDIF	TMR3IF	—	54
PIE2	OSCFIE	CMIE	—	—	BCLIE	LVDIE	TMR3IE	—	54
IPR2	OSCFIP	CMIP	—	—	BCLIP	LVDIP	TMR3IP	—	54
TMR3L	Timer3 Register Low Byte								53
TMR3H	Timer3 Register High Byte								53
T1CON	RD16	T1RUN	T1CKPS1	T1CKPS0	T1OSCEN	$\overline{T1SYNC}$	TMR1CS	TMR1ON	52
T3CON	RD16	T3CCP2	T3CKPS1	T3CKPS0	T3CCP1	$\overline{T3SYNC}$	TMR3CS	TMR3ON	53

Legend: — = unimplemented, read as '0'. Shaded cells are not used by the Timer3 module.

PIC18F85J90 FAMILY

NOTES:

PIC18F85J90 FAMILY

14.0 CAPTURE/COMPARE/PWM (CCP) MODULES

PIC18F85J90 family devices have two CCP (Capture/Compare/PWM) modules, designated CCP1 and CCP2. Both modules implement standard Capture, Compare and Pulse-Width Modulation (PWM) modes.

Each CCP module contains a 16-bit register which can operate as a 16-bit Capture register, a 16-bit Compare register or a PWM Master/Slave Duty Cycle register. For the sake of clarity, all CCP module operation in the following sections is described with respect to CCP2, but is equally applicable to CCP1.

REGISTER 14-1: CCPxCON: CCPx CONTROL REGISTER (CCP1, CCP2 MODULES)

U-0	U-0	R/W-0	R/W-0	R/W-0	R/W-0	R/W-0	R/W-0
—	—	DCxB1	DCxB0	CCPxM3	CCPxM2	CCPxM1	CCPxM0
bit 7							bit 0

Legend:

R = Readable bit

W = Writable bit

U = Unimplemented bit, read as '0'

-n = Value at POR

'1' = Bit is set

'0' = Bit is cleared

x = Bit is unknown

bit 7-6 **Unimplemented:** Read as '0'

bit 5-4 **DCxB1:DCxB0:** PWM Duty Cycle bit 1 and bit 0 for CCPx Module

Capture mode:

Unused.

Compare mode:

Unused.

PWM mode:

These bits are the two Least Significant bits (bit 1 and bit 0) of the 10-bit PWM duty cycle. The eight Most Significant bits (DCx9:DCx2) of the duty cycle are found in CCPxL.

bit 3-0 **CCPxM3:CCPxM0:** CCPx Module Mode Select bits

0000 = Capture/Compare/PWM disabled (resets CCPx module)

0001 = Reserved

0010 = Compare mode, toggle output on match (CCPxIF bit is set)

0011 = Reserved

0100 = Capture mode, every falling edge

0101 = Capture mode, every rising edge

0110 = Capture mode, every 4th rising edge

0111 = Capture mode, every 16th rising edge

1000 = Compare mode: initialize CCPx pin low; on compare match, force CCPx pin high (CCPxIF bit is set)

1001 = Compare mode: initialize CCPx pin high; on compare match, force CCPx pin low (CCPxIF bit is set)

1010 = Compare mode: generate software interrupt on compare match (CCPxIF bit is set, CCPx pin reflects I/O state)

1011 = Compare mode: Special Event Trigger; reset timer; start A/D conversion on CCPx match (CCPxIF bit is set)⁽¹⁾

11xx = PWM mode

Note 1: CCPxM3:CCPxM0 = 1011 will only reset timer and not start A/D conversion on CCP1 match.

PIC18F85J90 FAMILY

14.1 CCP Module Configuration

Each Capture/Compare/PWM module is associated with a control register (generically, CCPxCON) and a data register (CCPRx). The data register in turn is comprised of two 8-bit registers: CCPRxL (low byte) and CCPRxH (high byte). All registers are both readable and writable.

14.1.1 CCP MODULES AND TIMER RESOURCES

The CCP modules utilize Timers 1, 2 or 3, depending on the mode selected. Timer1 and Timer3 are available to modules in Capture or Compare modes, while Timer2 is available for modules in PWM mode.

TABLE 14-1: CCP MODE – TIMER RESOURCE

CCP Mode	Timer Resource
Capture	Timer1 or Timer3
Compare	Timer1 or Timer3
PWM	Timer2

The assignment of a particular timer to a module is determined by the Timer to CCP enable bits in the T3CON register (Register 13-1). Both modules may be active at any given time and may share the same timer resource if they are configured to operate in the same mode (Capture/Compare or PWM) at the same time. The interactions between the two modules are summarized in Table 14-2.

Depending on the configuration selected, up to four timers may be active at once, with modules in the same configuration (Capture/Compare or PWM) sharing timer resources. The possible configurations are shown in Figure 14-1.

14.1.2 OPEN-DRAIN OUTPUT OPTION

When operating in Output mode (i.e., in Compare or PWM modes), the drivers for the CCPx pins can be optionally configured as open-drain outputs. This feature allows the voltage level on the pin to be pulled to a higher level through an external pull-up resistor and allows the output to communicate with external circuits without the need for additional level shifters.

The open-drain output option is controlled by the CCP2OD and CCP1OD bits (TRISG<6:5>). Setting the appropriate bit configures the pin for the corresponding module for open-drain operation.

14.1.3 CCP2 PIN ASSIGNMENT

The pin assignment for CCP2 (Capture input, Compare and PWM output) can change, based on device configuration. The CCP2MX Configuration bit determines which pin CCP2 is multiplexed to. By default, it is assigned to RC1 (CCP2MX = 1). If the Configuration bit is cleared, CCP2 is multiplexed with RE7.

Changing the pin assignment of CCP2 does not automatically change any requirements for configuring the port pin. Users must always verify that the appropriate TRIS register is configured correctly for CCP2 operation, regardless of where it is located.

FIGURE 14-1: CCP AND TIMER INTERCONNECT CONFIGURATIONS

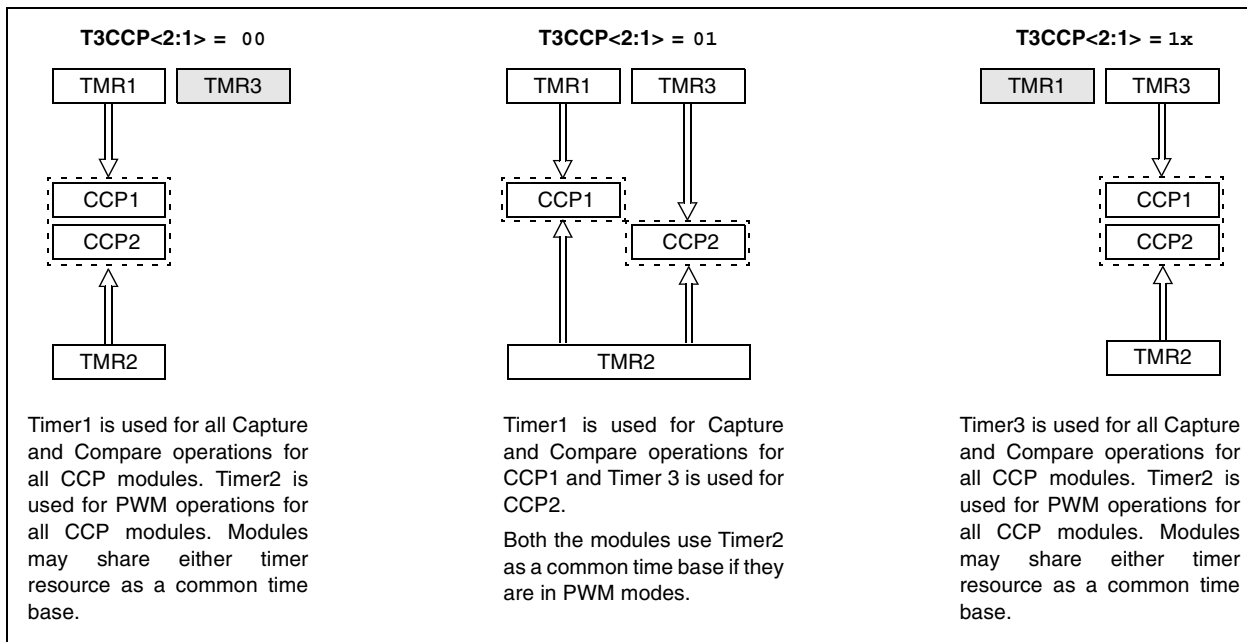

PIC18F85J90 FAMILY

TABLE 14-2: INTERACTIONS BETWEEN CCP1 AND CCP2 FOR TIMER RESOURCES

CCP1 Mode	CCP2 Mode	Interaction
Capture	Capture	Each module can use TMR1 or TMR3 as the time base. The time base can be different for each CCP.
Capture	Compare	CCP2 can be configured for the Special Event Trigger to reset TMR1 or TMR3 (depending upon which time base is used). Automatic A/D conversions on trigger event can also be done. Operation of CCP1 could be affected if it is using the same timer as a time base.
Compare	Capture	CCP1 can be configured for the Special Event Trigger to reset TMR1 or TMR3 (depending upon which time base is used). Operation of CCP2 could be affected if it is using the same timer as a time base.
Compare	Compare	Either module can be configured for the Special Event Trigger to reset the time base. Automatic A/D conversions on CCP2 trigger event can be done. Conflicts may occur if both modules are using the same time base.
Capture	PWM	None
Compare	PWM	None
PWM	Capture	None
PWM	Compare	None
PWM	PWM	Both PWMs will have the same frequency and update rate (TMR2 interrupt).

PIC18F85J90 FAMILY

14.2 Capture Mode

In Capture mode, the CCPR2H:CCPR2L register pair captures the 16-bit value of the TMR1 or TMR3 register when an event occurs on the CCP2 pin (RC1 or RE7, depending on device configuration). An event is defined as one of the following:

- every falling edge
- every rising edge
- every 4th rising edge
- every 16th rising edge

The event is selected by the mode select bits, CCP2M3:CCP2M0 (CCP2CON<3:0>). When a capture is made, the interrupt request flag bit, CCP2IF (PIR3<2>), is set; it must be cleared in software. If another capture occurs before the value in register CCPR2 is read, the old captured value is overwritten by the new captured value.

14.2.1 CCP PIN CONFIGURATION

In Capture mode, the appropriate CCPx pin should be configured as an input by setting the corresponding TRIS direction bit.

Note: If RC1/CCP2 or RE7/CCP2 is configured as an output, a write to the port can cause a capture condition.

14.2.2 TIMER1/TIMER3 MODE SELECTION

The timers that are to be used with the capture feature (Timer1 and/or Timer3) must be running in Timer mode or Synchronized Counter mode. In Asynchronous Counter mode, the capture operation may not work. The timer to be used with each CCP module is selected in the T3CON register (see Section 14.1.1 “CCP Modules and Timer Resources”).

14.2.3 SOFTWARE INTERRUPT

When the Capture mode is changed, a false capture interrupt may be generated. The user should keep the CCP2IE bit (PIE3<2>) clear to avoid false interrupts and should clear the flag bit, CCP2IF, following any such change in operating mode.

14.2.4 CCP PRESCALER

There are four prescaler settings in Capture mode. They are specified as part of the operating mode selected by the mode select bits (CCP2M3:CCP2M0). Whenever the CCP module is turned off, or the CCP module is not in Capture mode, the prescaler counter is cleared. This means that any Reset will clear the prescaler counter.

Switching from one capture prescaler to another may generate an interrupt. Also, the prescaler counter will not be cleared; therefore, the first capture may be from a non-zero prescaler. Example 14-1 shows the recommended method for switching between capture prescalers. This example also clears the prescaler counter and will not generate the “false” interrupt.

EXAMPLE 14-1: CHANGING BETWEEN CAPTURE PRESCALERS

```

CLRf CCP2CON      ; Turn CCP module off
MOVLW NEW_CAPT_PS ; Load WREG with the
                  ; new prescaler mode
                  ; value and CCP ON
MOVWF CCP2CON     ; Load CCP2CON with
                  ; this value
    
```

FIGURE 14-2: CAPTURE MODE OPERATION BLOCK DIAGRAM

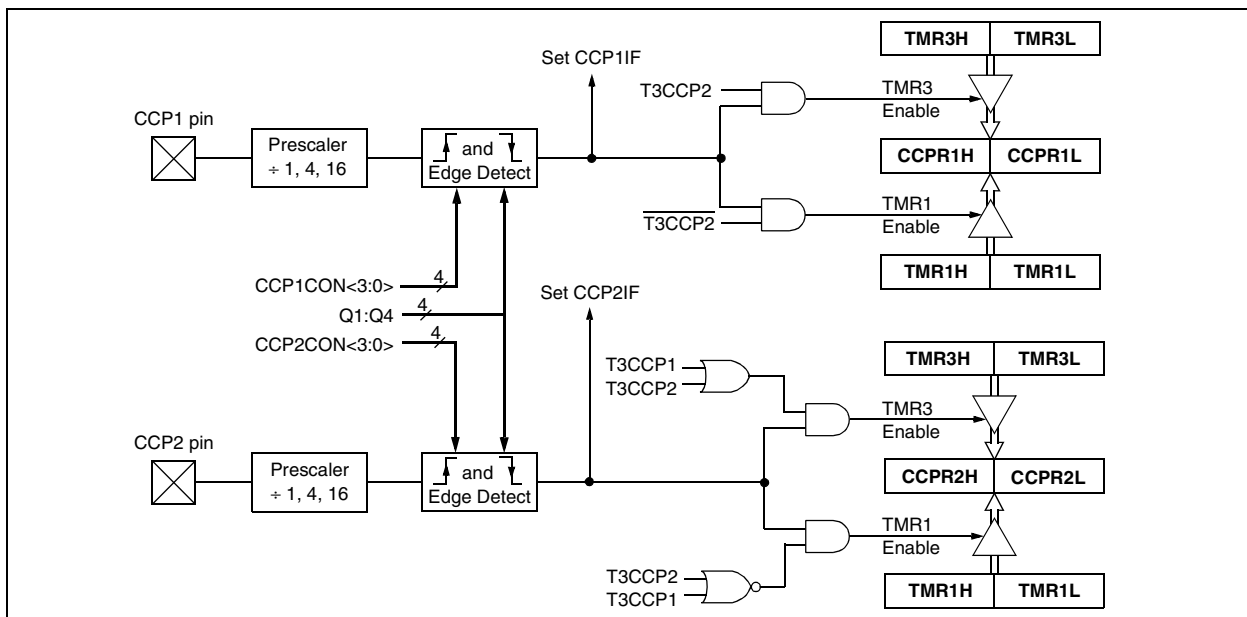

14.3 Compare Mode

In Compare mode, the 16-bit CCPR2 register value is constantly compared against either the TMR1 or TMR3 register pair value. When a match occurs, the CCP2 pin can be:

- driven high
- driven low
- toggled (high-to-low or low-to-high)
- remain unchanged (that is, reflects the state of the I/O latch)

The action on the pin is based on the value of the mode select bits (CCP2M3:CCP2M0). At the same time, the interrupt flag bit, CCP2IF, is set.

14.3.1 CCP PIN CONFIGURATION

The user must configure the CCPx pin as an output by clearing the appropriate TRIS bit.

Note: Clearing the CCP2CON register will force the RC1 or RE7 compare output latch (depending on device configuration) to the default low level. This is not the PORTC or PORTE I/O data latch.

14.3.2 TIMER1/TIMER3 MODE SELECTION

Timer1 and/or Timer3 must be running in Timer mode, or Synchronized Counter mode, if the CCP module is using the compare feature. In Asynchronous Counter mode, the compare operation may not work.

14.3.3 SOFTWARE INTERRUPT MODE

When the Generate Software Interrupt mode is chosen (CCP2M3:CCP2M0 = 1010), the CCP2 pin is not affected. Only a CCP interrupt is generated, if enabled, and the CCP2IE bit is set.

14.3.4 SPECIAL EVENT TRIGGER

Both CCP modules are equipped with a Special Event Trigger. This is an internal hardware signal generated in Compare mode to trigger actions by other modules. The Special Event Trigger is enabled by selecting the Compare Special Event Trigger mode (CCP2M3:CCP2M0 = 1011).

For either CCP module, the Special Event Trigger resets the timer register pair for whichever timer resource is currently assigned as the module's time base. This allows the CCPx registers to serve as a programmable period register for either timer.

The Special Event Trigger for CCP2 can also start an A/D conversion. In order to do this, the A/D converter must already be enabled.

Note: The Special Event Trigger of CCP1 only resets Timer1/Timer3 and cannot start an A/D conversion even when the A/D converter is enabled.

FIGURE 14-3: COMPARE MODE OPERATION BLOCK DIAGRAM

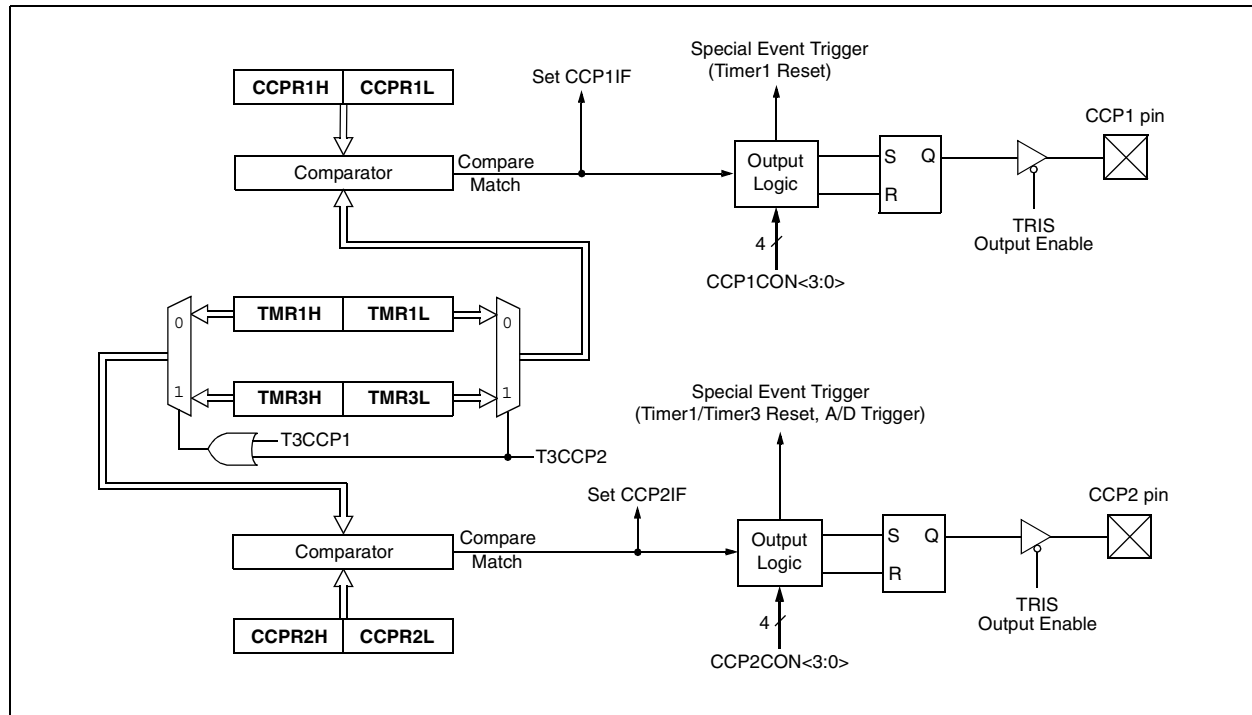

PIC18F85J90 FAMILY

TABLE 14-3: REGISTERS ASSOCIATED WITH CAPTURE, COMPARE, TIMER1 AND TIMER3

Name	Bit 7	Bit 6	Bit 5	Bit 4	Bit 3	Bit 2	Bit 1	Bit 0	Reset Values on Page
INTCON	GIE/GIEH	PEIE/GIEL	TMR0IE	INT0IE	RBIE	TMR0IF	INT0IF	RBIF	51
RCON	IPEN	—	—	\overline{RI}	\overline{TO}	\overline{PD}	\overline{POR}	\overline{BOR}	52
PIR3	—	LCDIF	RC2IF	TX2IF	—	CCP2IF	CCP1IF	—	54
PIE3	—	LCDIE	RC2IE	TX2IE	—	CCP2IE	CCP1IE	—	54
IPR3	—	LCDIP	RC2IP	TX2IP	—	CCP2IP	CCP1IP	—	54
PIR2	OSCFIF	CMIF	—	—	BCLIF	LVDIF	TMR3IF	—	54
PIE2	OSCFIE	CMIE	—	—	BCLIE	LVDIE	TMR3IE	—	54
IPR2	OSCFIP	CMIP	—	—	BCLIP	LVDIP	TMR3IP	—	54
TRISC	TRISC7	TRISC6	TRISC5	TRISC4	TRISC3	TRISC2	TRISC1	TRISC0	54
TRISE	TRISE7	TRISE6	TRISE5	TRISE4	TRISE3	—	TRISE1	TRISE0	54
TRISG	SPIOD	CCP2OD	CCP1OD	TRISG4	TRISG3	TRISG2	TRISG1	TRISG0	54
TMR1L	Timer1 Register Low Byte								52
TMR1H	Timer1 Register High Byte								52
T1CON	RD16	T1RUN	T1CKPS1	T1CKPS0	T1OSCEN	$\overline{T1SYNC}$	TMR1CS	TMR1ON	52
TMR3H	Timer3 Register High Byte								53
TMR3L	Timer3 Register Low Byte								53
T3CON	RD16	T3CCP2	T3CKPS1	T3CKPS0	T3CCP1	$\overline{T3SYNC}$	TMR3CS	TMR3ON	53
CCPR1L	Capture/Compare/PWM Register 1 Low Byte								55
CCPR1H	Capture/Compare/PWM Register 1 High Byte								55
CCP1CON	—	—	DC1B1	DC1B0	CCP1M3	CCP1M2	CCP1M1	CCP1M0	55
CCPR2L	Capture/Compare/PWM Register 2 Low Byte								56
CCPR2H	Capture/Compare/PWM Register 2 High Byte								55
CCP2CON	—	—	DC2B1	DC2B0	CCP2M3	CCP2M2	CCP2M1	CCP2M0	56

Legend: — = unimplemented, read as '0'. Shaded cells are not used by Capture/Compare, Timer1 or Timer3.

14.4 PWM Mode

In Pulse-Width Modulation (PWM) mode, the CCP2 pin produces up to a 10-bit resolution PWM output. Since the CCP2 pin is multiplexed with a PORTC or PORTE data latch, the appropriate TRIS bit must be cleared to make the CCP2 pin an output.

Note: Clearing the CCP2CON register will force the RC1 or RE7 output latch (depending on device configuration) to the default low level. This is not the PORTC or PORTE I/O data latch.

Figure 14-4 shows a simplified block diagram of the CCP1 module in PWM mode.

For a step-by-step procedure on how to set up the CCP module for PWM operation, see **Section 14.4.3 “Setup for PWM Operation”**.

FIGURE 14-4: SIMPLIFIED PWM BLOCK DIAGRAM

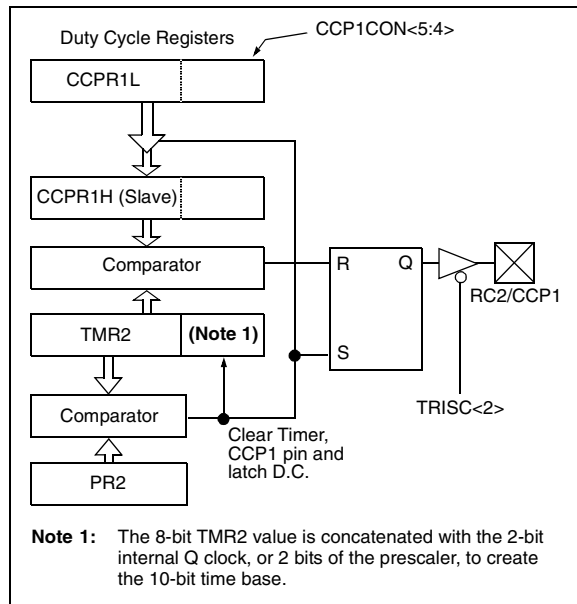

A PWM output (Figure 14-5) has a time base (period) and a time that the output stays high (duty cycle). The frequency of the PWM is the inverse of the period (1/period).

FIGURE 14-5: PWM OUTPUT

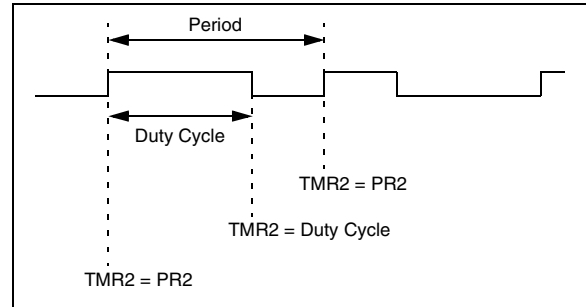

14.4.1 PWM PERIOD

The PWM period is specified by writing to the PR2 register. The PWM period can be calculated using the following formula:

EQUATION 14-1:

$$\text{PWM Period} = (\text{PR2} + 1) \cdot 4 \cdot \text{Tosc} \cdot (\text{TMR2 Prescale Value})$$

PWM frequency is defined as $1/[\text{PWM period}]$.

When TMR2 is equal to PR2, the following three events occur on the next increment cycle:

- TMR2 is cleared
- The CCP2 pin is set (exception: if PWM duty cycle = 0%, the CCP2 pin will not be set)
- The PWM duty cycle is latched from CCPR2L into CCPR2H

Note: The Timer2 postscalers (see **Section 12.0 “Timer2 Module”**) are not used in the determination of the PWM frequency. The postscaler could be used to have a servo update rate at a different frequency than the PWM output.

PIC18F85J90 FAMILY

14.4.2 PWM DUTY CYCLE

The PWM duty cycle is specified by writing to the CCPR2L register and to the CCP2CON<5:4> bits. Up to 10-bit resolution is available. The CCPR2L contains the eight MSbs and the CCP2CON<5:4> contains the two LSbs. This 10-bit value is represented by CCPR2L:CCP2CON<5:4>. The following equation is used to calculate the PWM duty cycle in time:

EQUATION 14-2:

$$\text{PWM Duty Cycle} = (\text{CCPR2L:CCP2CON<5:4>}) \cdot \text{TOSC} \cdot (\text{TMR2 Prescale Value})$$

CCPR2L and CCP2CON<5:4> can be written to at any time, but the duty cycle value is not latched into CCPR2H until after a match between PR2 and TMR2 occurs (i.e., the period is complete). In PWM mode, CCPR2H is a read-only register.

The CCPR2H register and a 2-bit internal latch are used to double-buffer the PWM duty cycle. This double-buffering is essential for glitchless PWM operation.

When the CCPR2H and 2-bit latch match TMR2, concatenated with an internal 2-bit Q clock or 2 bits of the TMR2 prescaler, the CCP2 pin is cleared.

The maximum PWM resolution (bits) for a given PWM frequency is given by the equation:

EQUATION 14-3:

$$\text{PWM Resolution (max)} = \frac{\log\left(\frac{F_{\text{OSC}}}{F_{\text{PWM}}}\right)}{\log(2)} \text{ bits}$$

Note: If the PWM duty cycle value is longer than the PWM period, the CCP2 pin will not be cleared.

TABLE 14-4: EXAMPLE PWM FREQUENCIES AND RESOLUTIONS AT 40 MHz

PWM Frequency	2.44 kHz	9.77 kHz	39.06 kHz	156.25 kHz	312.50 kHz	416.67 kHz
Timer Prescaler (1, 4, 16)	16	4	1	1	1	1
PR2 Value	FFh	FFh	FFh	3Fh	1Fh	17h
Maximum Resolution (bits)	14	12	10	8	7	6.58

PIC18F85J90 FAMILY

14.4.3 SETUP FOR PWM OPERATION

The following steps should be taken when configuring the CCP module for PWM operation:

1. Set the PWM period by writing to the PR2 register.
2. Set the PWM duty cycle by writing to the CCPR2L register and CCP2CON<5:4> bits.
3. Make the CCP2 pin an output by clearing the appropriate TRIS bit.
4. Set the TMR2 prescale value, then enable Timer2 by writing to T2CON.
5. Configure the CCP2 module for PWM operation.

TABLE 14-5: REGISTERS ASSOCIATED WITH PWM AND TIMER2

Name	Bit 7	Bit 6	Bit 5	Bit 4	Bit 3	Bit 2	Bit 1	Bit 0	Reset Values on Page
INTCON	GIE/GIEH	PEIE/GIEL	TMR0IE	INT0IE	RBIE	TMR0IF	INT0IF	RBIF	51
RCON	IPEN	—	—	\overline{RI}	\overline{TO}	\overline{PD}	\overline{POR}	\overline{BOR}	52
PIR1	—	ADIF	RC1IF	TX1IF	SSPIF	—	TMR2IF	TMR1IF	54
PIE1	—	ADIE	RC1IE	TX1IE	SSPIE	—	TMR2IE	TMR1IE	54
IPR1	—	ADIP	RC1IP	TX1IP	SSPIP	—	TMR2IP	TMR1IP	54
TRISC	TRISC7	TRISC6	TRISC5	TRISC4	TRISC3	TRISC2	TRISC1	TRISC0	54
TRISE	TRISE7	TRISE6	TRISE5	TRISE4	TRISE3	—	TRISE1	TRISE0	54
TRISG	SPIOD	CCP2OD	CCP1OD	TRISG4	TRISG3	TRISG2	TRISG1	TRISG0	54
TMR2	Timer2 Register								52
PR2	Timer2 Period Register								52
T2CON	—	T2OUTPS3	T2OUTPS2	T2OUTPS1	T2OUTPS0	TMR2ON	T2CKPS1	T2CKPS0	52
CCPR1L	Capture/Compare/PWM Register 1 Low Byte								55
CCPR1H	Capture/Compare/PWM Register 1 High Byte								55
CCP1CON	—	—	DC1B1	DC1B0	CCP1M3	CCP1M2	CCP1M1	CCP1M0	55
CCPR2L	Capture/Compare/PWM Register 2 Low Byte								56
CCPR2H	Capture/Compare/PWM Register 2 High Byte								55
CCP2CON	—	—	DC2B1	DC2B0	CCP2M3	CCP2M2	CCP2M1	CCP2M0	56

Legend: — = unimplemented, read as '0'. Shaded cells are not used by PWM or Timer2.

PIC18F85J90 FAMILY

NOTES:

15.0 LIQUID CRYSTAL DISPLAY (LCD) DRIVER MODULE

The Liquid Crystal Display (LCD) driver module generates the timing control to drive a static or multiplexed LCD panel. It also provides control of the LCD pixel data. The module can drive panels of up to 192 pixels (48 segments by 4 commons) in 80-pin devices, and 132 pixels (33 segments by 4 commons) in 64-pin devices.

The LCD driver module supports these features:

- Direct driving of LCD panel
- On-chip bias generator with dedicated charge pump to support a range of fixed and variable bias options
- Up to four commons, with four Multiplexing modes
- Up to 48 (80-pin devices) or 33 (64-pin devices) segments
- Three LCD clock sources with selectable prescaler, with a fourth source available for use with the LCD charge pump

A simplified block diagram of the module is shown in Figure 15-1.

FIGURE 15-1: LCD DRIVER MODULE BLOCK DIAGRAM

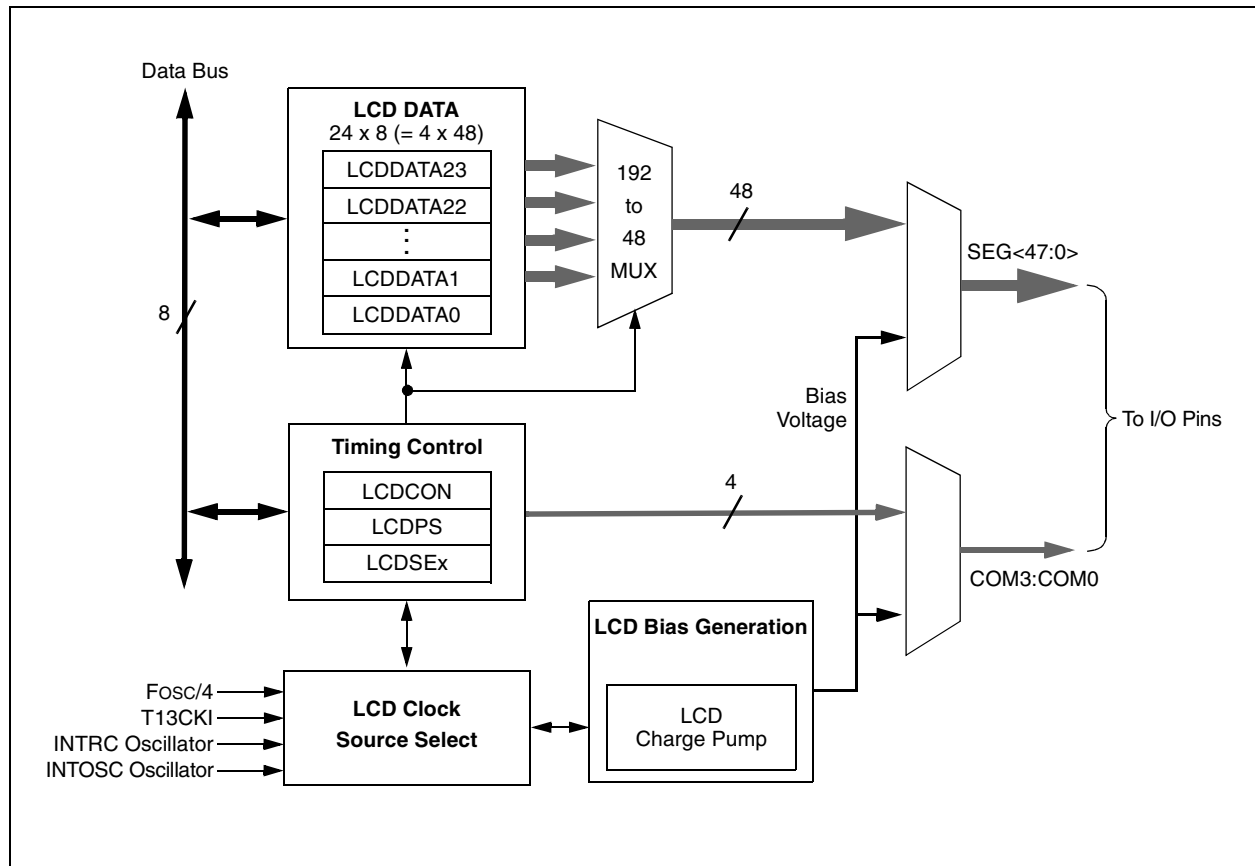

PIC18F85J90 FAMILY

15.1 LCD Registers

The LCD driver module has 33 registers:

- LCD Control Register (LCDCON)
- LCD Phase Register (LCDPS)
- LCDREG Register (LCD Regulator Control)
- Six LCD Segment Enable Registers (LCDSE5:LCDSE0)
- 24 LCD Data Registers (LCDDATA23:LCDDATA0)

15.1.1 LCD CONTROL REGISTERS

The LCDCON register, shown in Register 15-1, controls the overall operation of the module. Once the module is configured, the LCDEN (LCDCON<7>) bit is used to enable or disable the LCD module. The LCD panel can also operate during Sleep by clearing the SLPEN (LCDCON<6>) bit.

The LCDPS register, shown in Register 15-2, configures the LCD clock source prescaler and the type of waveform: Type-A or Type-B. Details on these features are provided in **Section 15.2 “LCD Clock Source”**, **Section 15.3 “LCD Bias Generation”** and **Section 15.8 “LCD Waveform Generation”**.

The LCDREG register is described in **Section 15.3 “LCD Bias Generation”**.

The LCD Segment Enable registers (LCDSE_x) configure the functions of the port pins. Setting the segment enable bit for a particular segment configures that pin as an LCD driver. The prototype LCDSE register is shown in Register 15-3. There are six LCDSE registers (LCDSE5:LCDSE0), listed in Table 15-1.

REGISTER 15-1: LCDCON: LCD CONTROL REGISTER

R/W-0	R/W-0	R/C-0	U-0	R/W-0	R/W-0	R/W-0	R/W-0
LCDEN	SLPEN	WERR	—	CS1	CS0	LMUX1	LMUX0
bit 7							bit 0

Legend:	C = Clearable bit		
R = Readable bit	W = Writable bit	U = Unimplemented bit, read as '0'	
-n = Value at POR	'1' = Bit is set	'0' = Bit is cleared	x = Bit is unknown

- bit 7 **LCDEN:** LCD Driver Enable bit
 1 = LCD driver module is enabled
 0 = LCD driver module is disabled
- bit 6 **SLPEN:** LCD Driver Enable in Sleep mode bit
 1 = LCD driver module is disabled in Sleep mode
 0 = LCD driver module is enabled in Sleep mode
- bit 5 **WERR:** LCD Write Failed Error bit
 1 = LCDDATA_x register written while LCDPS<4> = 0 (must be cleared in software)
 0 = No LCD write error
- bit 4 **Unimplemented:** Read as '0'
- bit 3-2 **CS1:CS0:** Clock Source Select bits
 1_x = INTRC (31 kHz)
 01 = T13CKI (Timer1)
 00 = System clock (FOSC/4)
- bit 1-0 **LMUX1:LMUX0:** Commons Select bits

LMUX1: LMUX0	Multiplex Type	Maximum Number of Pixels:		Bias Type
		PIC18F6XJ90	PIC18F8XJ90	
00	Static (COM0)	33	48	Static
01	1/2 (COM1:COM0)	66	96	1/2 or 1/3
10	1/3 (COM2:COM0)	99	144	1/2 or 1/3
11	1/4 (COM3:COM0)	132	192	1/3

PIC18F85J90 FAMILY

REGISTER 15-2: LCDPS: LCD PHASE REGISTER

R/W-0	R/W-0	R-0	R-0	R/W-0	R/W-0	R/W-0	R/W-0
WFT	BIASMD	LCDA	WA	LP3	LP2	LP1	LP0
bit 7							bit 0

Legend:

R = Readable bit	W = Writable bit	U = Unimplemented bit, read as '0'
-n = Value at POR	'1' = Bit is set	'0' = Bit is cleared
		x = Bit is unknown

- bit 7 **WFT:** Waveform Type Select bit
 1 = Type-B waveform (phase changes on each frame boundary)
 0 = Type-A waveform (phase changes within each common type)
- bit 6 **BIASMD:** Bias Mode Select bit
 When LMUX1:LMUX0 = 00:
 0 = Static Bias mode (do not set this bit to '1')
- When LMUX1:LMUX0 = 01 or 10:
 1 = 1/2 Bias mode
 0 = 1/3 Bias mode
- When LMUX1:LMUX0 = 11:
 0 = 1/3 Bias mode (do not set this bit to '1')
- bit 5 **LCDA:** LCD Active Status bit
 1 = LCD driver module is active
 0 = LCD driver module is inactive
- bit 4 **WA:** LCD Write Allow Status bit
 1 = Write into the LCDDATAx registers is allowed
 0 = Write into the LCDDATAx registers is not allowed
- bit 3-0 **LP3:LP0:** LCD Prescaler Select bits
 1111 = 1:16
 1110 = 1:15
 1101 = 1:14
 1100 = 1:13
 1011 = 1:12
 1010 = 1:11
 1001 = 1:10
 1000 = 1:9
 0111 = 1:8
 0110 = 1:7
 0101 = 1:6
 0100 = 1:5
 0011 = 1:4
 0010 = 1:3
 0001 = 1:2
 0000 = 1:1

PIC18F85J90 FAMILY

REGISTER 15-3: LCDSE_x: LCD SEGMENT ENABLE REGISTERS

R/W-0	R/W-0	R/W-0	R/W-0	R/W-0	R/W-0	R/W-0	R/W-0
SE(n + 7)	SE(n + 6)	SE(n + 5)	SE(n + 4)	SE(n + 3)	SE(n + 2)	SE(n + 1)	SE(n)
bit 7							bit 0

Legend:

R = Readable bit

W = Writable bit

U = Unimplemented bit, read as '0'

-n = Value at POR

'1' = Bit is set

'0' = Bit is cleared

x = Bit is unknown

bit 7-0 **SEG(n + 7):SEG(n)**: Segment Enable bits

For LCDSE0: n = 0

For LCDSE1: n = 8

For LCDSE2: n = 16

For LCDSE3: n = 24

For LCDSE4: n = 32

For LCDSE5: n = 40

1 = Segment function of the pin is enabled, digital I/O disabled

0 = I/O function of the pin is enabled

TABLE 15-1: LCDSE REGISTERS AND ASSOCIATED SEGMENTS

Register	Segments
LCDSE0	7:0
LCDSE1	15:8
LCDSE2	23:16
LCDSE3	31:24
LCDSE4 ⁽¹⁾	39:32
LCDSE5 ⁽²⁾	47:40

Note 1: LCDSE4<7:1> (SEG39:SEG33) are not implemented in 64-pin devices.

2: LCDSE5 is not implemented in 64-pin devices.

PIC18F85J90 FAMILY

15.1.2 LCD DATA REGISTERS

Once the module is initialized for the LCD panel, the individual bits of the LCDDATA23:LCDDATA0 registers are cleared or set to represent a clear or dark pixel, respectively. Specific sets of LCDDATA registers are used with specific segments and common signals. Each bit represents a unique combination of a specific segment connected to a specific common.

Individual LCDDATA bits are named by the convention “SxxCy”, with “xx” as the segment number and “y” as the common number. The relationship is summarized in Table 15-2. The prototype LCDDATA register is shown in Register 15-4.

Note: In 64-pin devices, writing into the registers LCDDATA5, LCDDATA11, LCDDATA17, and LCDDATA23 will not affect the status of any pixels.

REGISTER 15-4: LCDDATAx: LCD DATA REGISTERS

R/W-0	R/W-0	R/W-0	R/W-0	R/W-0	R/W-0	R/W-0	R/W-0
S(n + 7)Cy	S(n + 6)Cy	S(n + 5)Cy	S(n + 4)Cy	S(n + 3)Cy	S(n + 2)Cy	S(n + 1)Cy	S(n)Cy
bit 7							bit 0

Legend:

R = Readable bit	W = Writable bit	U = Unimplemented bit, read as '0'
-n = Value at POR	'1' = Bit is set	'0' = Bit is cleared
		x = Bit is unknown

bit 7-0 **S(n + 7)Cy:S(n)Cy:** Pixel On bits
 For LCDDATA0 through LCDDATA5: n = (8x), y = 0
 For LCDDATA6 through LCDDATA11: n = (8(x - 6)), y = 1
 For LCDDATA12 through LCDDATA17: n = (8(x - 12)), y = 2
 For LCDDATA18 through LCDDATA23: n = (8(x - 18)), y = 3
 1 = Pixel on (dark)
 0 = Pixel off (clear)

TABLE 15-2: LCDDATA REGISTERS AND BITS FOR SEGMENT AND COM COMBINATIONS

Segments	COM Lines			
	0	1	2	3
0 through 7	LCDDATA0	LCDDATA6	LCDDATA12	LCDDATA18
	S00C0:S07C0	S00C1:S07C1	S00C2:S07C2	S00C3:S07C3
8 through 15	LCDDATA1	LCDDATA7	LCDDATA13	LCDDATA19
	S08C0:S15C0	S08C1:S15C1	S08C2:S15C2	S08C3:S15C3
16 through 23	LCDDATA2	LCDDATA8	LCDDATA14	LCDDATA20
	S16C0:S23C0	S16C1:S23C1	S16C2:S23C2	S16C3:S23C3
24 through 31	LCDDATA3	LCDDATA9	LCDDATA15	LCDDATA21
	S24C0:S31C0	S24C1:S31C1	S24C2:S31C2	S24C3:S31C3
32 through 39	LCDDATA4 ⁽¹⁾	LCDDATA10 ⁽¹⁾	LCDDATA16 ⁽¹⁾	LCDDATA22 ⁽¹⁾
	S32C0:S39C0	S32C1:S39C1	S32C2:S39C2	S32C3:S39C3
40 through 47	LCDDATA5 ⁽²⁾	LCDDATA11 ⁽²⁾	LCDDATA17 ⁽²⁾	LCDDATA23 ⁽²⁾
	S40C0:S47C0	S40C1:S47C1	S40C2:S47C2	S40C3:S47C3

Note 1: Bits <7:1> of these registers are not implemented in 64-pin devices. Bit 0 of these registers (SEG32Cy) is always implemented.

2: These registers are not implemented on 64-pin devices.

PIC18F85J90 FAMILY

15.2 LCD Clock Source

The LCD driver module generates its internal clock from 3 possible sources:

- System clock ($F_{osc}/4$)
- Timer1 oscillator
- INTRC source

The LCD clock generator uses a configurable divide-by-32/divide-by-8192 postscaler to produce a baseline frequency of about 1 kHz nominal, regardless of the source selected. The clock source selection and the postscaler configuration are determined by the Clock Source Select bits, CS1:CS0 (LCDCON<3:2>).

An additional programmable prescaler is used to derive the LCD frame frequency from the 1 kHz baseline. The prescaler is configured using the LP3:LP0 bits (LCDPS<3:0>) for any one of 16 options, ranging from 1:1 to 1:16.

Proper timing for waveform generation is set by the LMUX1:LMUX0 bits (LCDCON<1:0>). These bits determine which Commons Multiplexing mode is to be used, and divide down the LCD clock source as required. They also determine the configuration of the ring counter that is used to switch the LCD commons on or off.

15.2.1 LCD VOLTAGE REGULATOR CLOCK SOURCE

In addition to the clock source for LCD timing, a separate 31 kHz nominal clock is required for the LCD charge pump. This is provided from a distinct branch of the LCD clock source.

The charge pump clock can use either the Timer1 oscillator or the INTRC source, as well as the 8 MHz INTOSC source (after being divided by 256 by a prescaler). The charge pump clock source is configured using the CKSEL1:CKSEL0 bits (LCDREG<1:0>).

15.2.2 CLOCK SOURCE CONSIDERATIONS

When using the system clock as the LCD clock source, it is assumed that the system clock frequency is a nominal 32 MHz (for a $F_{osc}/4$ frequency of 8 MHz). Because the prescaler option for the $F_{osc}/4$ clock selection is fixed at divide-by-8192, system clock speeds that differ from 32 MHz will produce frame frequencies and refresh rates different than discussed in this chapter. The user will need to keep this in mind when designing the display application.

The Timer1 and INTRC sources can be used as LCD clock sources when the device is in Sleep mode. To use the Timer1 oscillator, it is necessary to set the T1OSCEN bit (T1CON<3>). Selecting either Timer1 or INTRC as the LCD clock source will not automatically activate these sources.

Similarly, selecting the INTOSC as the charge pump clock source will not turn the oscillator on. To use INTOSC, it must be selected as the system clock source by using the FOSC2 Configuration bit.

If Timer1 is used as a clock source for the device, either as an LCD clock source or for any other purpose, LCD segment 32 become unavailable.

FIGURE 15-2: LCD CLOCK GENERATION

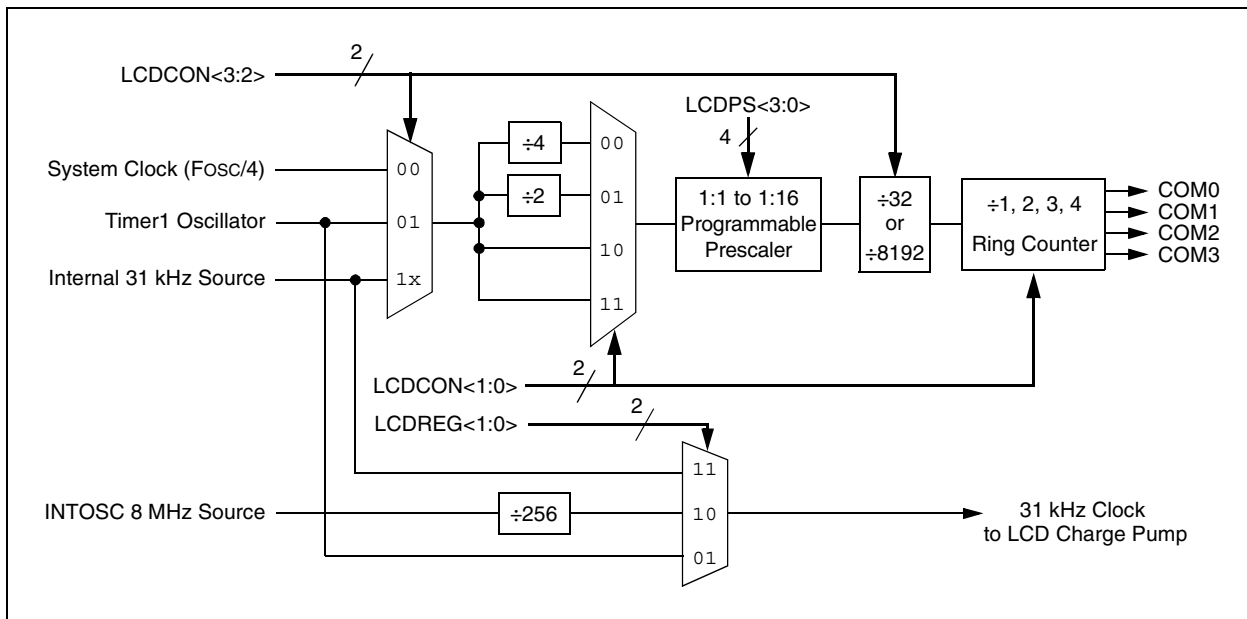

PIC18F85J90 FAMILY

15.3 LCD Bias Generation

The LCD driver module is capable of generating the required bias voltages for LCD operation with a minimum of external components. This includes the ability to generate the different voltage levels required by the different bias types required by the LCD. The driver module can also provide bias voltages both above and below microcontroller VDD through the use of an on-chip LCD voltage regulator.

15.3.1 LCD BIAS TYPES

PIC18F85J90 family devices support three bias types based on the waveforms generated to control segments and commons:

- Static (two discrete levels)
- 1/2 Bias (three discrete levels)
- 1/3 Bias (four discrete levels)

The use of different waveforms in driving the LCD is discussed in more detail in **Section 15.8 “LCD Waveform Generation”**.

15.3.2 LCD VOLTAGE REGULATOR

The purpose of the LCD regulator is to provide proper bias voltage and good contrast for the LCD, regardless of VDD levels. This module contains a charge pump and internal voltage reference. The regulator can be configured by using external components to boost bias voltage above VDD. It can also operate a display at a constant voltage below VDD. The regulator can also be selectively disabled to allow bias voltages to be generated by an external resistor network.

The LCD regulator is controlled through the LCDREG register (Register 15-5). It is enabled or disabled using the CKSEL1:CKSEL0 bits, while the charge pump can be selectively enabled using the CPEN bit. When the regulator is enabled, the MODE13 bit is used to select the bias type. The peak LCD bias voltage, measured as a difference between the potentials of LCDBIAS3 and LCDBIAS0, is configured with the BIAS bits.

REGISTER 15-5: LCDREG: VOLTAGE REGULATOR CONTROL REGISTER

U-0	RW-0	RW-1	RW-1	RW-1	RW-1	RW-0	RW-0
—	CPEN	BIAS2	BIAS1	BIAS0	MODE13	CKSEL1	CKSEL0
bit 7							bit 0

Legend:

R = Readable bit	W = Writable bit	U = Unimplemented bit, read as '0'
-n = Value at POR	'1' = Bit is set	'0' = Bit is cleared
		x = Bit is unknown

- bit 7 **Unimplemented:** Read as '0'
- bit 6 **CPEN:** LCD Charge Pump Enable bit
 - 1 = Charge pump enabled; highest LCD bias voltage is 3.6V
 - 0 = Charge pump disabled; highest LCD bias voltage is AVDD
- bit 5-3 **BIAS2:BIAS0:** Regulator Voltage Output Control bits
 - 111 = 3.60V peak (offset on LCDBIAS0 of 0V)
 - 110 = 3.47V peak (offset on LCDBIAS0 of 0.13V)
 - 101 = 3.34V peak (offset on LCDBIAS0 of 0.26V)
 - 100 = 3.21V peak (offset on LCDBIAS0 of 0.39V)
 - 011 = 3.08V peak (offset on LCDBIAS0 of 0.52V)
 - 010 = 2.95V peak (offset on LCDBIAS0 of 0.65V)
 - 001 = 2.82V peak (offset on LCDBIAS0 of 0.78V)
 - 000 = 2.69V peak (offset on LCDBIAS0 of 0.91V)
- bit 2 **MODE13:** 1/3 LCD Bias Enable bit
 - 1 = Regulator output supports 1/3 LCD Bias mode
 - 0 = Regulator output supports static LCD Bias mode
- bit 1-0 **CKSEL1:CKSEL0:** Regulator Clock Source Select bits
 - 11 = INTRC
 - 10 = INTOSC 8 MHz source
 - 01 = Timer1 oscillator
 - 00 = LCD regulator disabled

PIC18F85J90 FAMILY

15.3.3 BIAS CONFIGURATIONS

PIC18F85J90 family devices have four distinct circuit configurations for LCD bias generation:

- M0: Regulator with Boost
- M1: Regulator without Boost
- M2: Resistor Ladder with Software Contrast
- M3: Resistor Ladder with Hardware Contrast

15.3.3.1 M0 (Regulator with Boost)

In M0 operation, the LCD charge pump feature is enabled. This allows the regulator to generate voltages up to +3.6V to the LCD (as measured at LCDBIAS3).

M0 uses a flyback capacitor connected between VLCAP1 and VLCAP2, as well as filter capacitors on LCDBIAS0 through LCDBIAS3, to obtain the required voltage boost (Figure 15-3). The output voltage (V_{BIAS}) is the difference of potential between LCDBIAS3 and LCDBIAS0. It is set by the BIAS2:BIAS0 bits which adjust the offset between LCDBIAS0 and V_{SS} . The flyback capacitor (C_{FLY}) acts as a charge storage element for large LCD loads. This mode is useful in those cases where the voltage requirements of the LCD are higher than the microcontroller's V_{DD} . It also permits software control of the display's contrast by adjustment of bias voltage by changing the value of the BIAS bits.

M0 supports Static and 1/3 Bias types. Generation of the voltage levels for 1/3 Bias is handled automatically, but must be configured in software.

M0 is enabled by selecting a valid regulator clock source ($CKSEL<1:0>$ set to any value except '00') and setting the CPEN bit. If static Bias type is required, the MODE13 bit must be cleared.

15.3.3.2 M1 (Regulator without Boost)

M1 operation is similar to M0, but does not use the LCD charge pump. It can provide V_{BIAS} up to the voltage level supplied directly to LCDBIAS3. It can be used in cases where V_{DD} for the application is expected to never drop below a level that can provide adequate contrast for the LCD. The connection of external components is very similar to M0, except that LCDBIAS3 must be tied directly to V_{DD} (Figure 15-3).

The BIAS<2:0> bits can still be used to adjust contrast in software by changing V_{BIAS} . As with M0, changing these bits changes the offset between LCDBIAS0 and V_{SS} . In M1, this is reflected in the change between the LCDBIAS0 and the voltage tied to LCDBIAS3. Thus, if V_{DD} should change, V_{BIAS} will also change; where in M0, the level of V_{BIAS} is constant.

Like M0, M1 supports Static and 1/3 Bias types. Generation of the voltage levels for 1/3 Bias is handled automatically but must be configured in software.

M1 is enabled by selecting a valid regulator clock source ($CKSEL<1:0>$ set to any value except '00') and clearing the CPEN bit. If 1/3 Bias type is required, the MODE13 bit should also be set.

FIGURE 15-3: LCD REGULATOR CONNECTIONS FOR M0 AND M1 CONFIGURATIONS

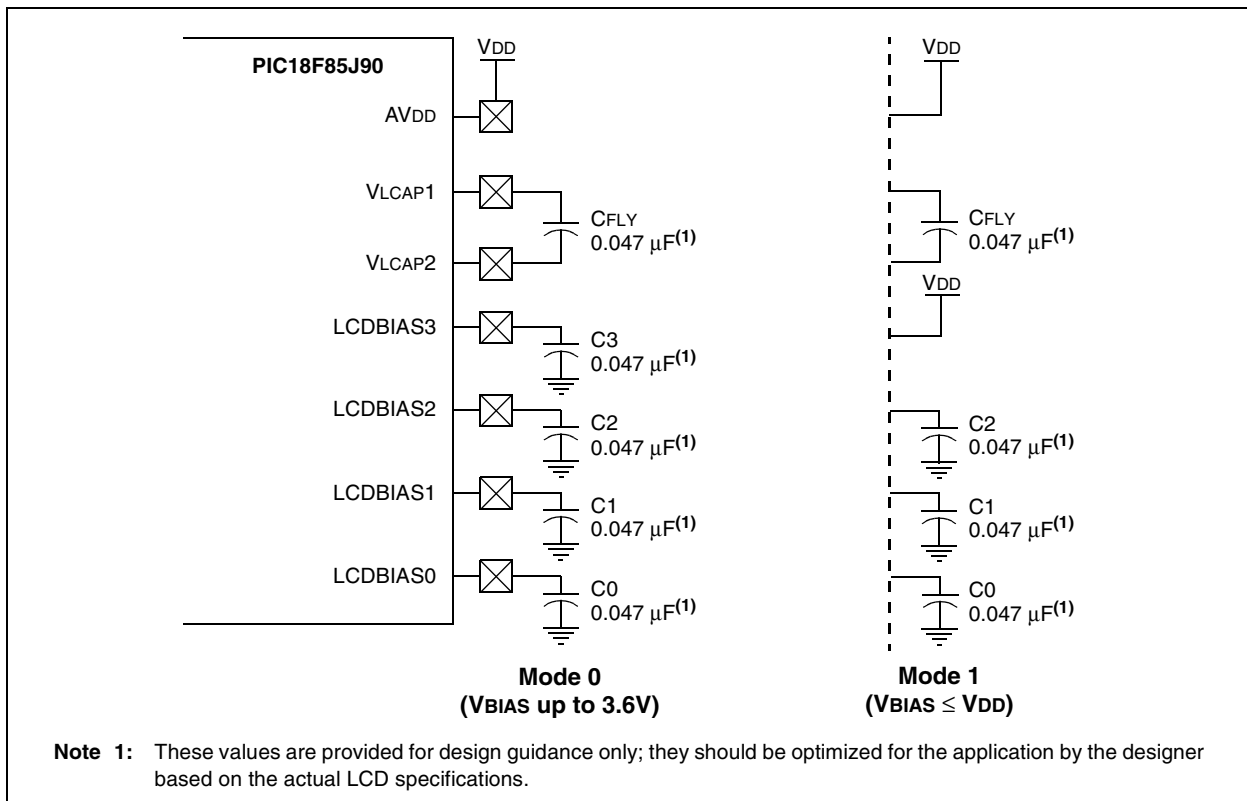

15.3.3.3 M2 (Resistor Ladder with Software Contrast)

M2 operation also uses the LCD regulator but disables the charge pump. The regulator's internal voltage reference remains active as a way to regulate contrast. It is used in cases where the current requirements of the LCD exceed the capacity of the regulator's charge pump.

In this configuration, the LCD bias voltage levels are created by an external resistor voltage divider connected across LCDBIAS0 through LCDBIAS3, with the top of the divider tied to V_{DD} (Figure 15-4). The potential at the bottom of the ladder is determined by the LCD regulator's voltage reference, tied internally to LCDBIAS0. The bias type is determined by the voltages on the LCDBIAS pins, which are controlled by the

configuration of the resistor ladder. Most applications using M2 will use a 1/3 or 1/2 Bias type. While Static Bias can also be used, it offers extremely limited contrast range and additional current consumption over other bias generation modes.

Like M1, the LCDBIAS bits can be used to control contrast, limited by the level of V_{DD} supplied to the device. Also, since there is no capacitor required across VLCAP1 and VLCAP2, these pins are available as digital I/O ports, RG2 and RG3.

M2 is selected by clearing the CKSEL<1:0> bits and setting the CPEN bit.

FIGURE 15-4: RESISTOR LADDER CONNECTIONS FOR CONFIGURATION M2

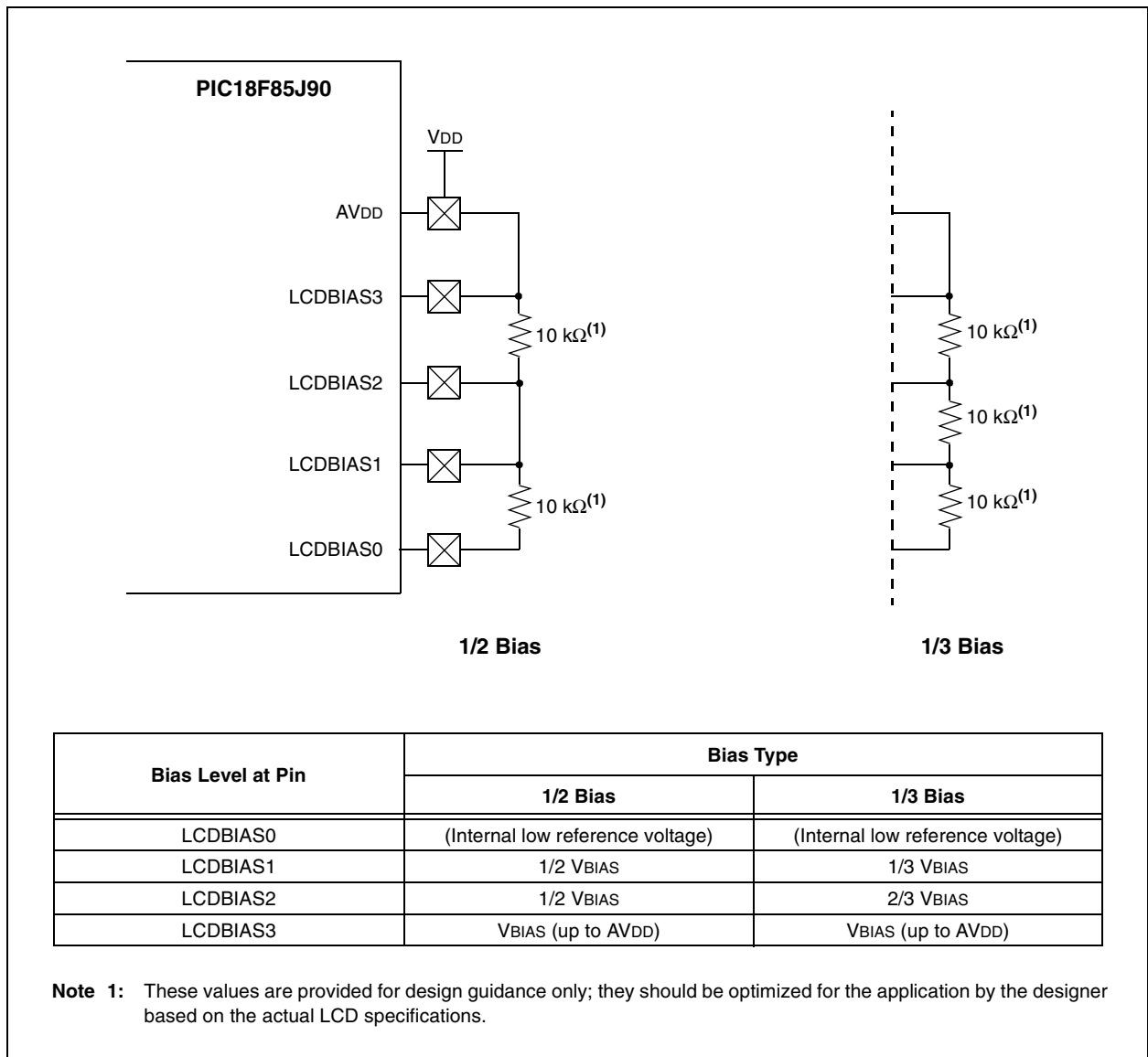

PIC18F85J90 FAMILY

15.3.3.4 M3 (Hardware Contrast)

In M3, the LCD regulator is completely disabled. Like M2, LCD bias levels are tied to AVDD, and are generated using an external divider. The difference is that the internal voltage reference is also disabled and the bottom of the ladder is tied to ground (VSS); see Figure 15-5. The value of the resistors and the difference between VSS and VDD determine the contrast range; no software adjustment is possible. This configuration is also used where the LCD's current requirements exceed the capacity of the charge pump, and software contrast control is not needed.

Depending on the bias type required, resistors are connected between some or all of the pins. A potentiometer can also be connected between LCDBIAS3 and VDD to allow for hardware controlled contrast adjustment.

M3 is selected by clearing the CKSEL<1:0> and CPEN bits.

FIGURE 15-5: RESISTOR LADDER CONNECTIONS FOR CONFIGURATION M3

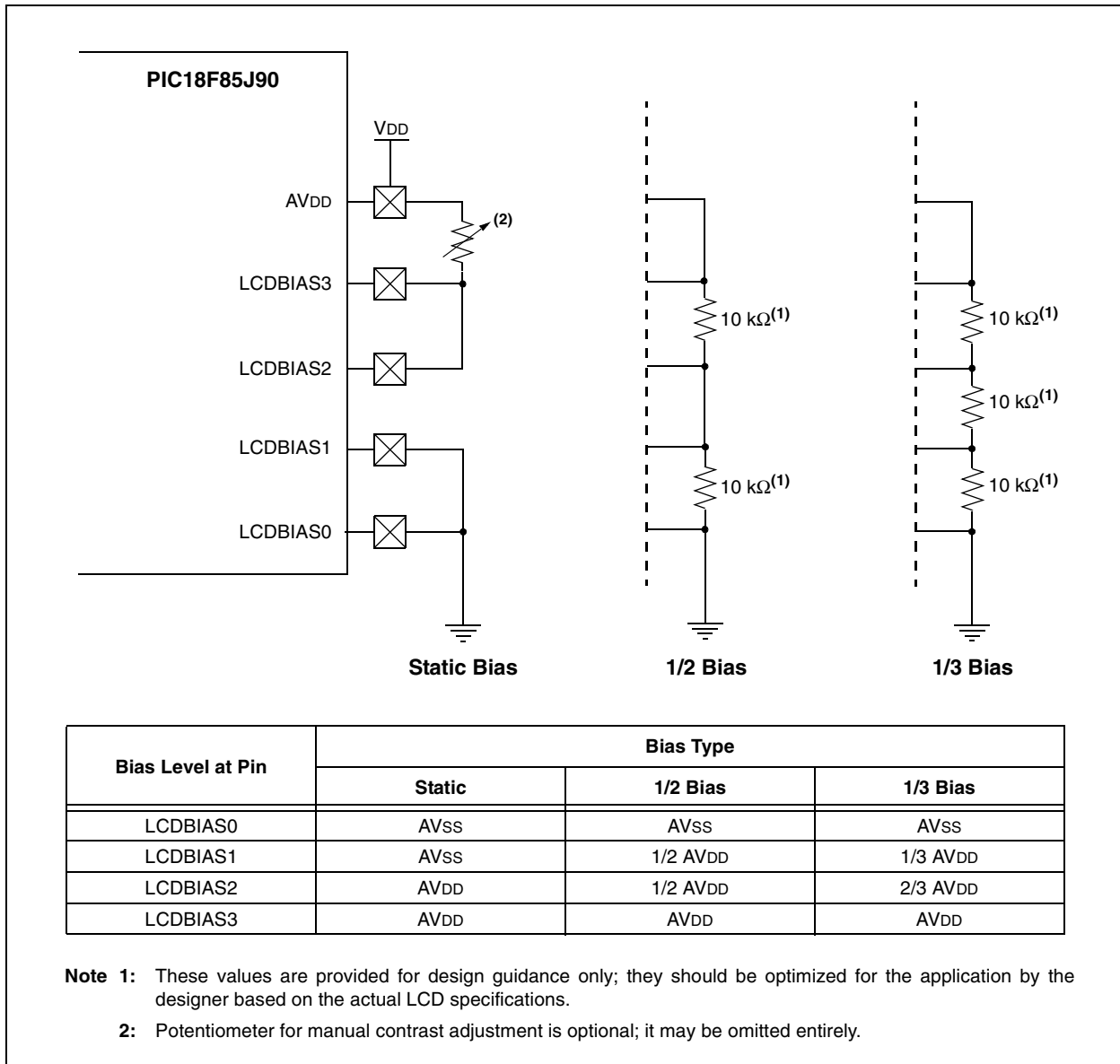

15.3.4 DESIGN CONSIDERATIONS FOR THE LCD CHARGE PUMP

When designing applications that use the LCD regulator with the charge pump enabled, users must always consider both the dynamic current and RMS (static) current requirements of the display, and what the charge pump can deliver. Both dynamic and static current can be determined by Equation 15-1:

EQUATION 15-1:

$$I = C \times \frac{dV}{dT}$$

For dynamic current, C is the value of the capacitors attached to LCDBIAS3 and LCDBIAS2. The variable, dV , is the voltage drop allowed on C2 and C3 during a voltage switch on the LCD display, and dT is the duration of the transient current after a clock pulse occurs. For practical design purposes, these will be assumed to be 0.047 μF for C , 0.1V for dV and 1 μs for dT . This yields a dynamic current of 4.7 mA for 1 μs .

RMS current is determined by the value of C_{FLY} for C , the voltage across VLCAP1 and VLCAP2 for dV and the regulator clock period (T_{PER}) for dT . Assuming C_{FLY} of 0.047 μF , a value of 1.02V across C_{FLY} and T_{PER} of 30 μs , the maximum theoretical static current will be 1.8 mA. Since the charge pump must charge five capacitors, the maximum current becomes 360 μA . For a real-world assumption of 50% efficiency, this yields a practical current of 180 μA .

Users should compare the calculated current capacity against the requirements of the LCD. While dV and dT are relatively fixed by device design, the values of C_{FLY} and the capacitors on the LCDBIAS pins can be changed to increase or decrease current. As always, any changes should be evaluated in the actual circuit for its impact on the application.

15.4 LCD Multiplex Types

The LCD driver module can be configured into four multiplex types:

- Static (only COM0 used)
- 1/2 multiplex (COM0 and COM1 are used)
- 1/3 multiplex (COM0, COM1 and COM2 are used)
- 1/4 multiplex (all COM0, COM1, COM2 and COM3 are used)

The number of active commons used is configured by the LMUX1:LMUX0 bits (LCDCON<1:0>), which determines the function of the PORTE<6:4> pins (see Table 15-3 for details). If the pin is configured as a COM drive, the port I/O function is disabled and the TRIS setting of that pin is overridden.

Note: On a Power-on Reset, the LMUX1:LMUX0 bits are '00'.

TABLE 15-3: PORTE<6:4> FUNCTION

LMUX1:LMUX0	PORTE<6>	PORTE<5>	PORTE<4>
00	Digital I/O	Digital I/O	Digital I/O
01	Digital I/O	Digital I/O	COM1 Driver
10	Digital I/O	COM2 Driver	COM1 Driver
11	COM3 Driver	COM2 Driver	COM1 Driver

15.5 Segment Enables

The LCDSEx registers are used to select the pin function for each segment pin. Setting a bit configures the corresponding pin to function as a segment driver. LCDSEx registers do not override the TRIS bit settings, so the TRIS bits must be configured as input for that pin.

Note: On a Power-on Reset, these pins are configured as digital I/O.

15.6 Pixel Control

The LCDDATAx registers contain bits which define the state of each pixel. Each bit defines one unique pixel.

Table 15-2 shows the correlation of each bit in the LCDDATAx registers to the respective common and segment signals. Any LCD pixel location not being used for display can be used as general purpose RAM.

PIC18F85J90 FAMILY

15.7 LCD Frame Frequency

The rate at which the COM and SEG outputs changes is called the LCD frame frequency. Frame frequency is set by the LP3:LP0 bits (LCDPS<3:0>), and is also affected by the Multiplex mode being used. The relationship between the Multiplex mode, LP bits setting and frame rate is shown in Table 15-4 and Table 15-5.

TABLE 15-4: FRAME FREQUENCY FORMULAS

Multiplex Mode	Frame Frequency (Hz)
Static	$\text{Clock source}/(4 \times 1 \times (\text{LP3:LP0} + 1))$
1/2	$\text{Clock source}/(2 \times 2 \times (\text{LP3:LP0} + 1))$
1/3	$\text{Clock source}/(1 \times 3 \times (\text{LP3:LP0} + 1))$
1/4	$\text{Clock source}/(1 \times 4 \times (\text{LP3:LP0} + 1))$

TABLE 15-5: APPROXIMATE FRAME FREQUENCY (IN Hz) FOR LP PRESCALER SETTINGS

LP3:LP0	Multiplex Mode			
	Static	1/2	1/3	1/4
1	125	125	167	125
2	83	83	111	83
3	62	62	83	62
4	50	50	67	50
5	42	42	56	42
6	36	36	48	36
7	31	31	42	31

15.8 LCD Waveform Generation

LCD waveform generation is based on the principle that the net AC voltage across the dark pixel should be maximized and the net AC voltage across the clear pixel should be minimized. The net DC voltage across any pixel should be zero.

The COM signal represents the time slice for each common, while the SEG contains the pixel data. The pixel signal (COM-SEG) will have no DC component and it can take only one of the two rms values. The higher rms value will create a dark pixel and a lower rms value will create a clear pixel.

As the number of commons increases, the delta between the two rms values decreases. The delta represents the maximum contrast that the display can have.

The LCDs can be driven by two types of waveform: Type-A and Type-B. In the Type-A waveform, the phase changes within each common type, whereas in the Type-B waveform, the phase changes on each frame boundary. Thus, the Type-A waveform maintains 0 VDC over a single frame, whereas the Type-B waveform takes two frames.

- Note 1:** If the power-managed Sleep mode is invoked while the LCD Sleep bit is set (LCDCON<6> is '1'), take care to execute Sleep only when the VDC on all the pixels is '0'.
- 2:** When the LCD clock source is the system clock, the LCD module will go to Sleep if the microcontroller goes into Sleep mode, regardless of the setting of the SLEN bit. Thus, always take care to see that the VDC on all pixels is '0' whenever Sleep mode is invoked.

Figure 15-6 through Figure 15-16 provide waveforms for static, half multiplex, one-third multiplex and quarter multiplex drives for Type-A and Type-B waveforms.

PIC18F85J90 FAMILY

FIGURE 15-6: TYPE-A/TYPE-B WAVEFORMS IN STATIC DRIVE

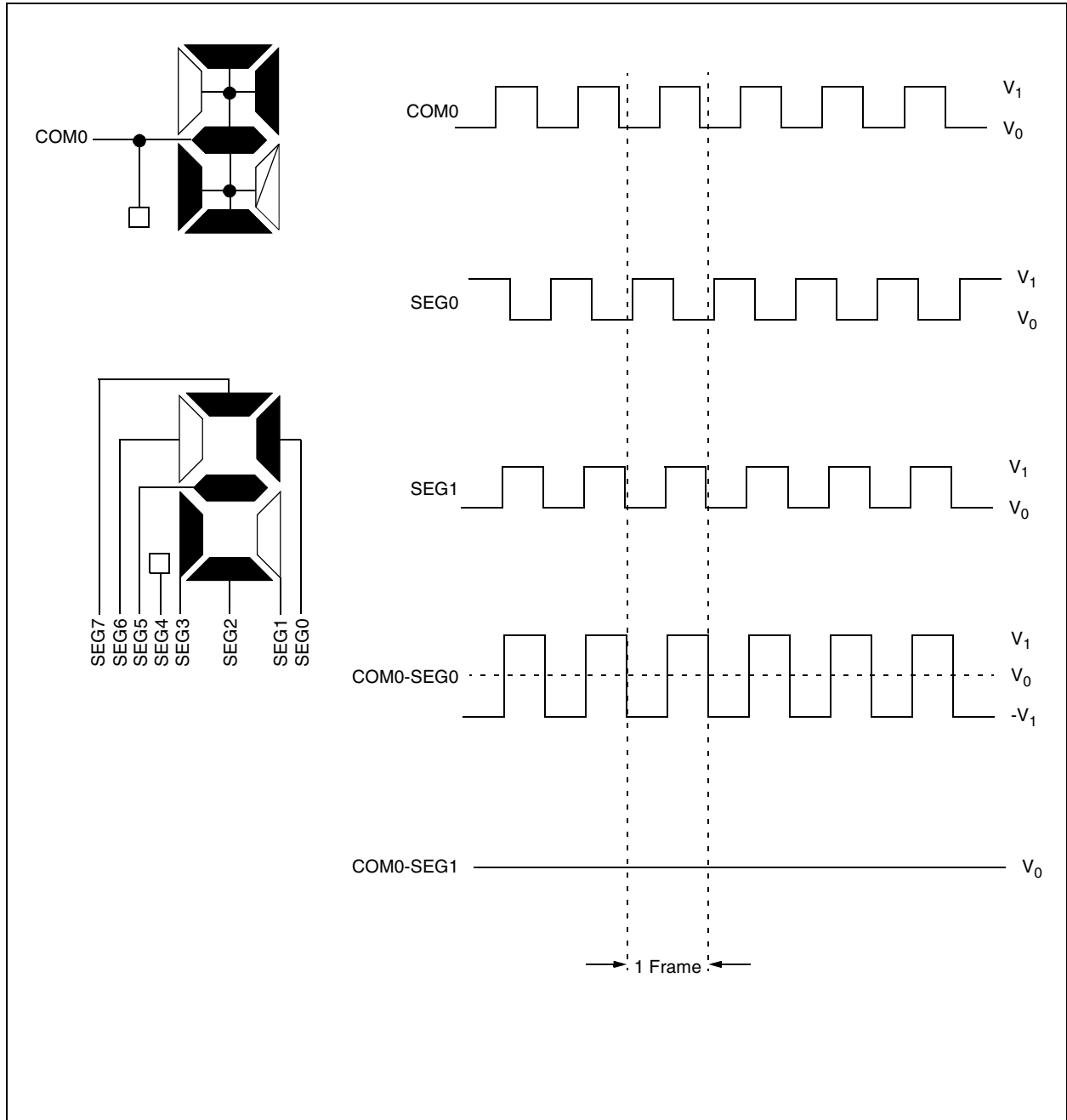

PIC18F85J90 FAMILY

FIGURE 15-7: TYPE-A WAVEFORMS IN 1/2 MUX, 1/2 BIAS DRIVE

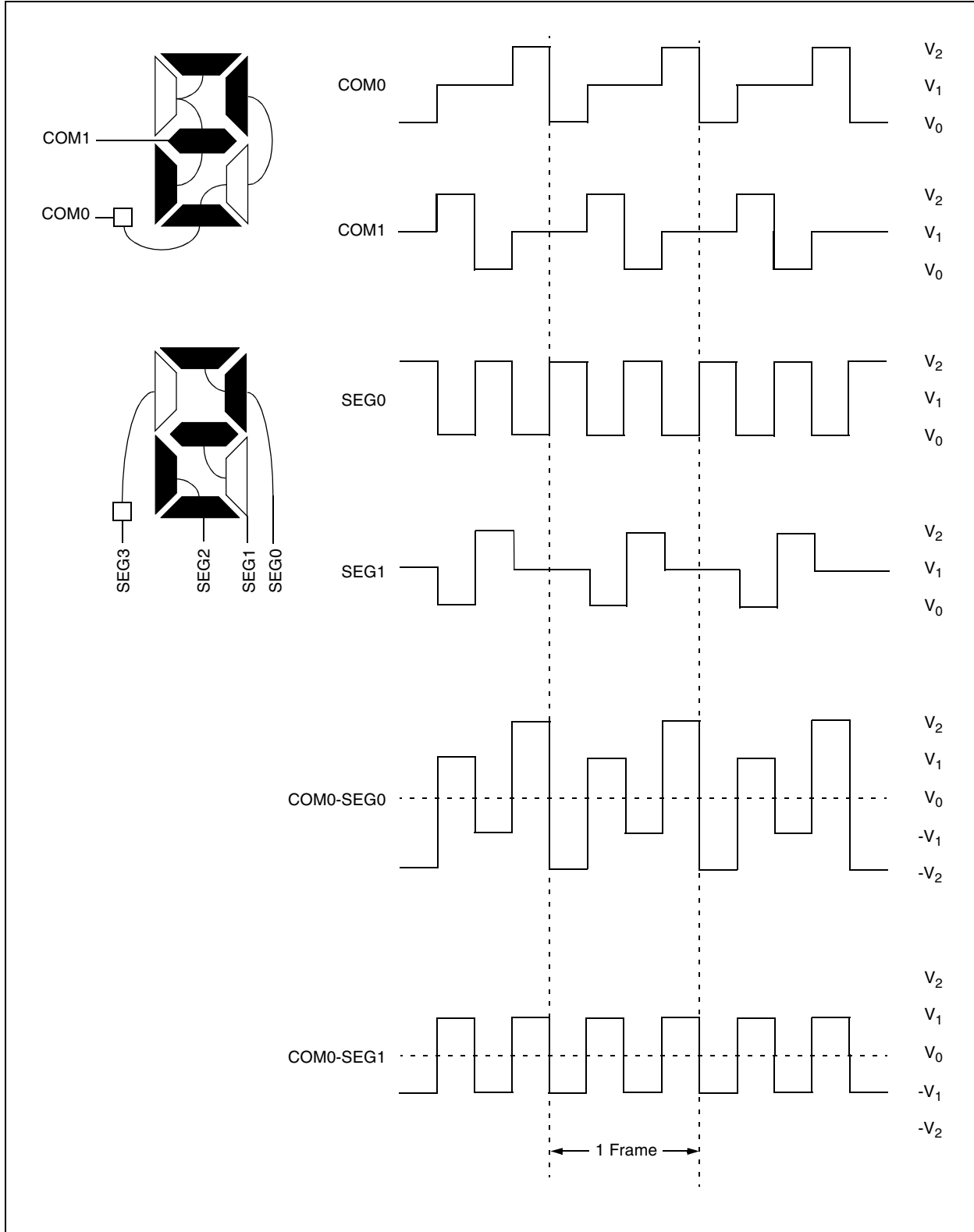

PIC18F85J90 FAMILY

FIGURE 15-8: TYPE-B WAVEFORMS IN 1/2 MUX, 1/2 BIAS DRIVE

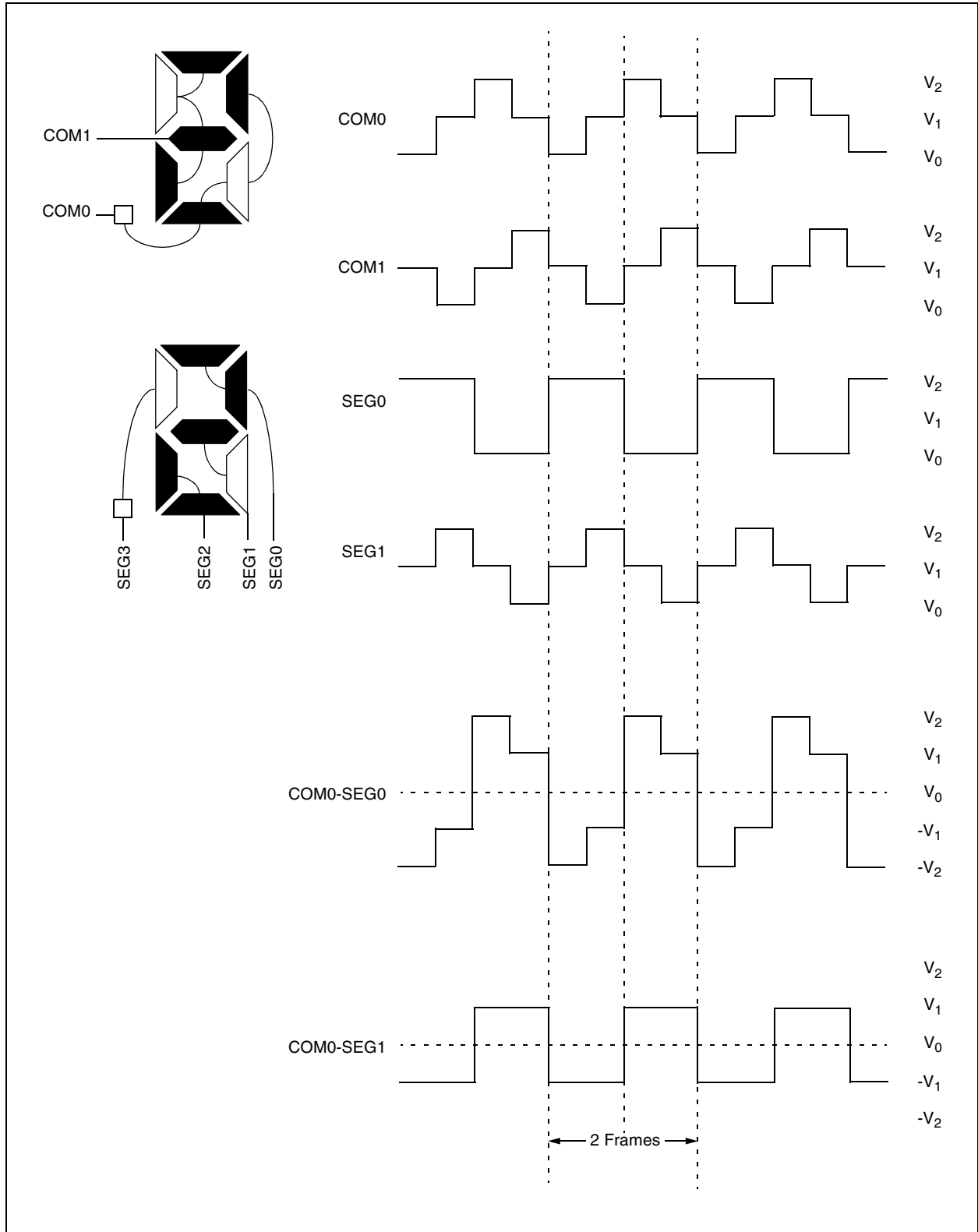

PIC18F85J90 FAMILY

FIGURE 15-9: TYPE-A WAVEFORMS IN 1/2 MUX, 1/3 BIAS DRIVE

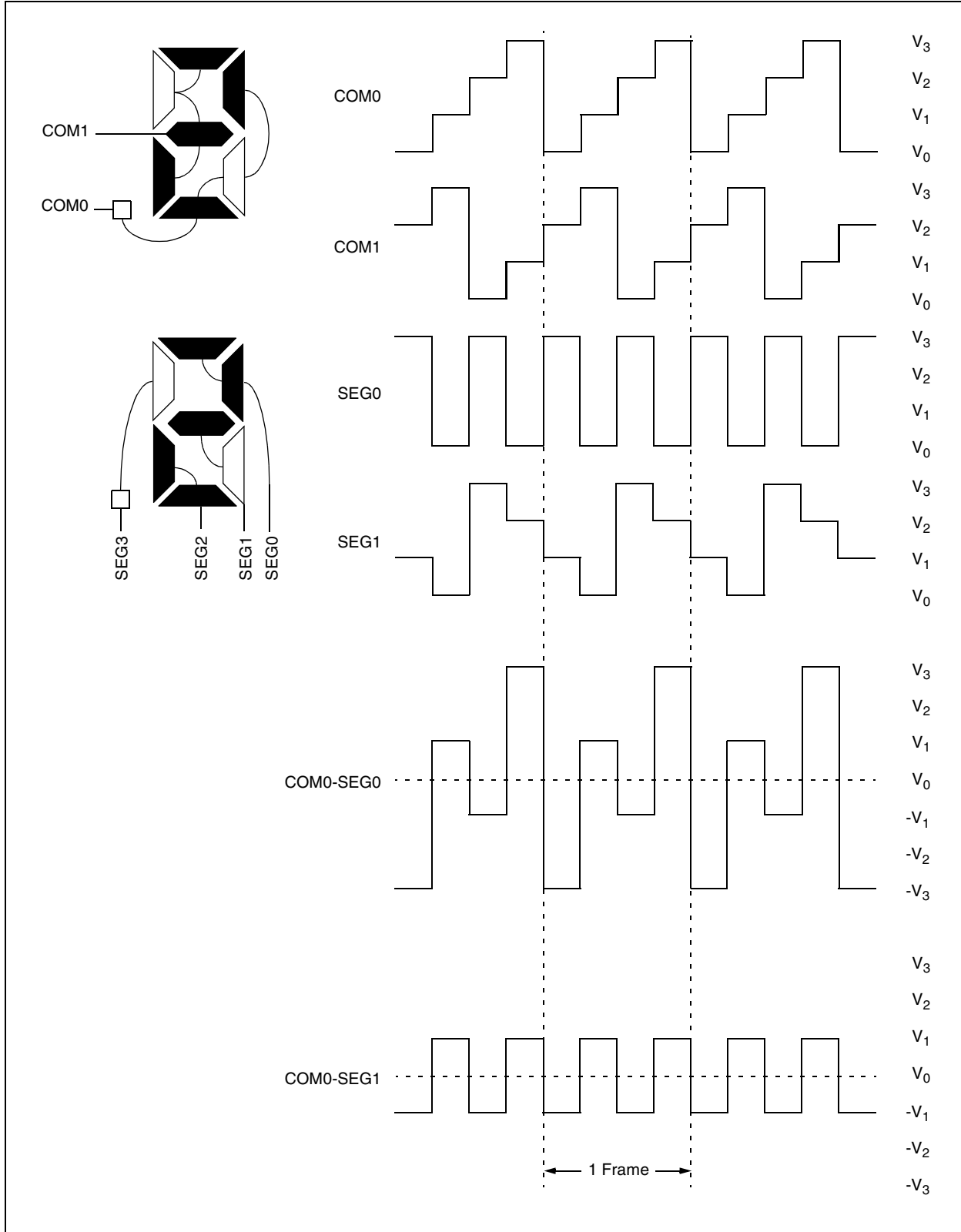

PIC18F85J90 FAMILY

FIGURE 15-10: TYPE-B WAVEFORMS IN 1/2 MUX, 1/3 BIAS DRIVE

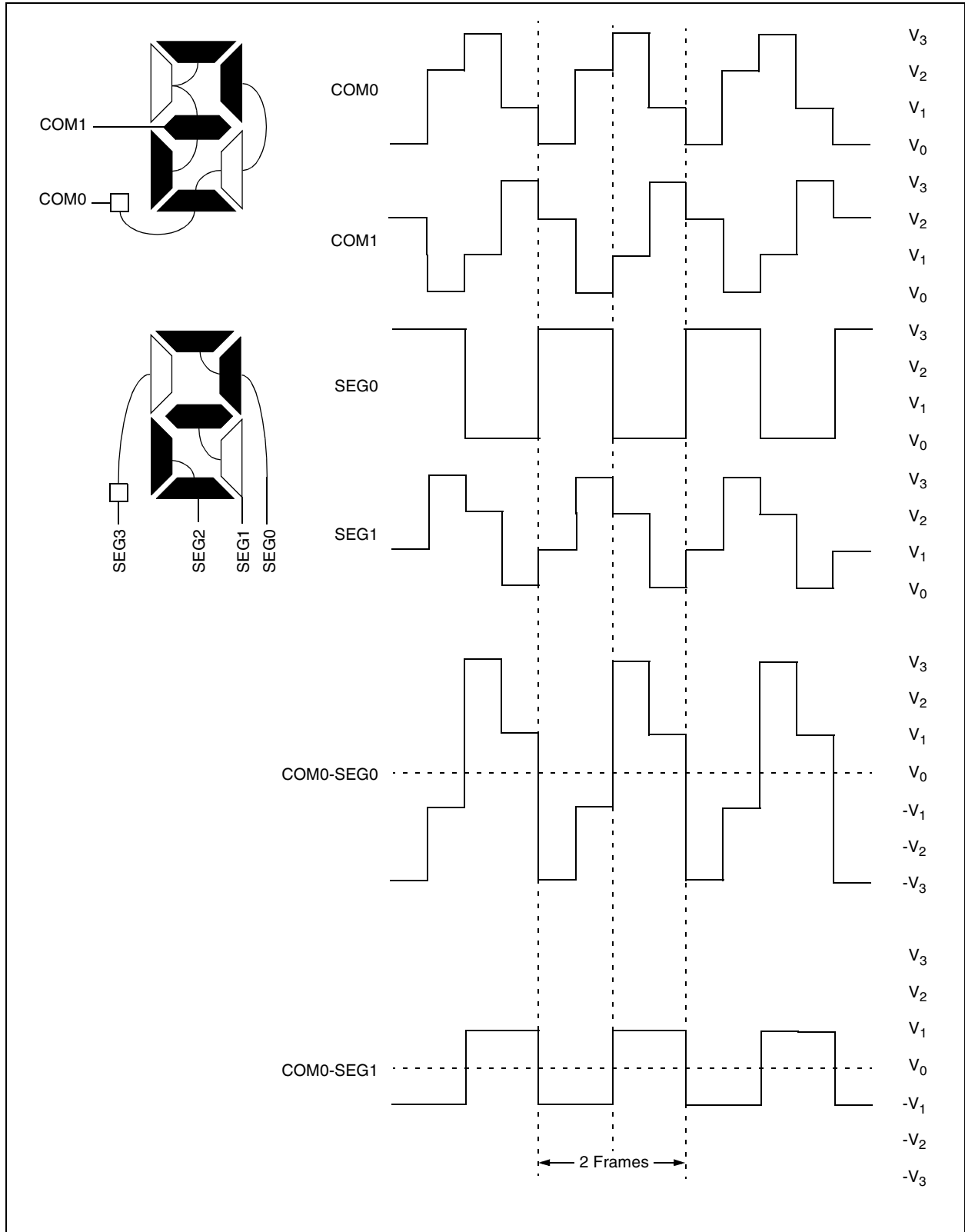

PIC18F85J90 FAMILY

FIGURE 15-11: TYPE-A WAVEFORMS IN 1/3 MUX, 1/2 BIAS DRIVE

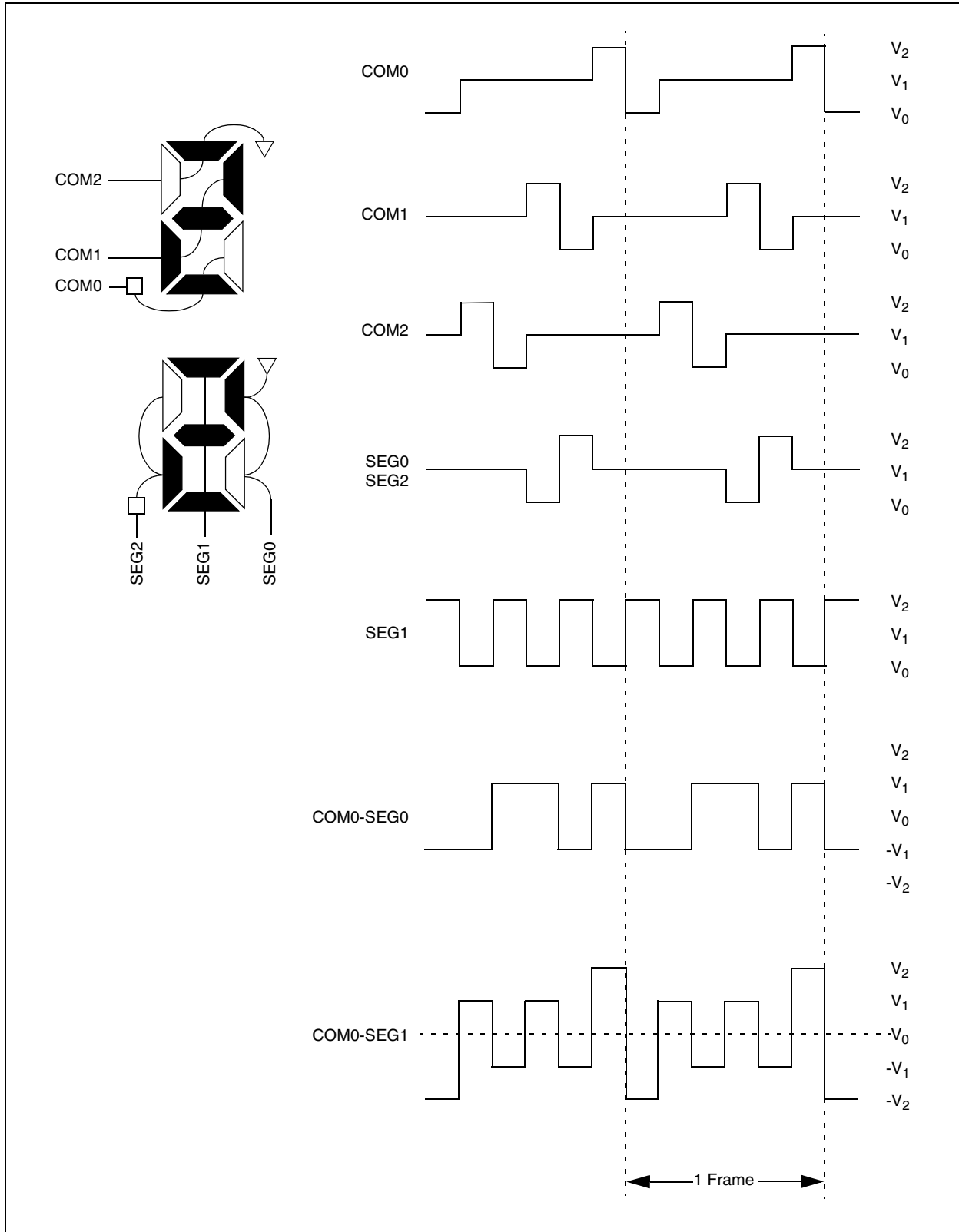

PIC18F85J90 FAMILY

FIGURE 15-12: TYPE-B WAVEFORMS IN 1/3 MUX, 1/2 BIAS DRIVE

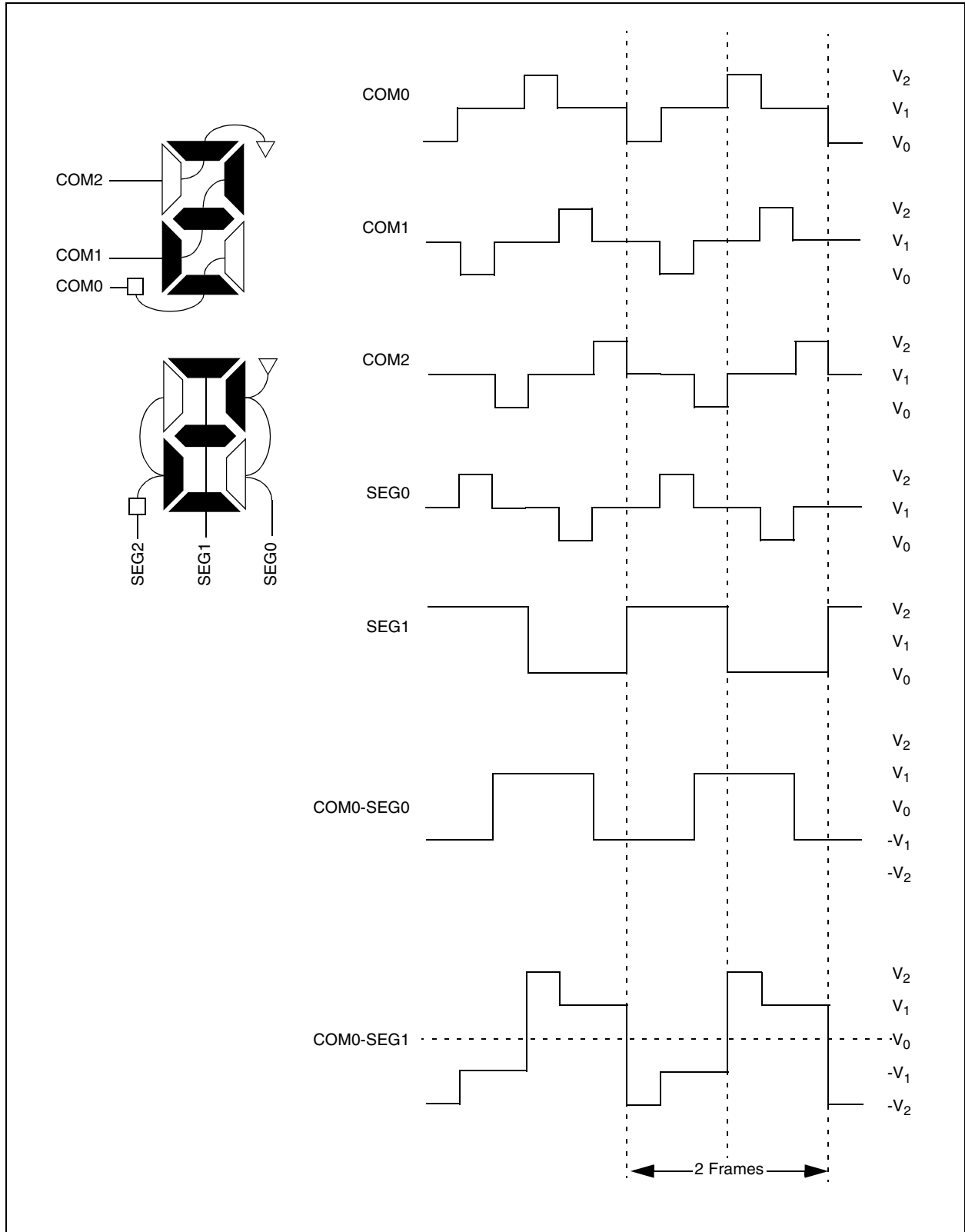

PIC18F85J90 FAMILY

FIGURE 15-13: TYPE-A WAVEFORMS IN 1/3 MUX, 1/3 BIAS DRIVE

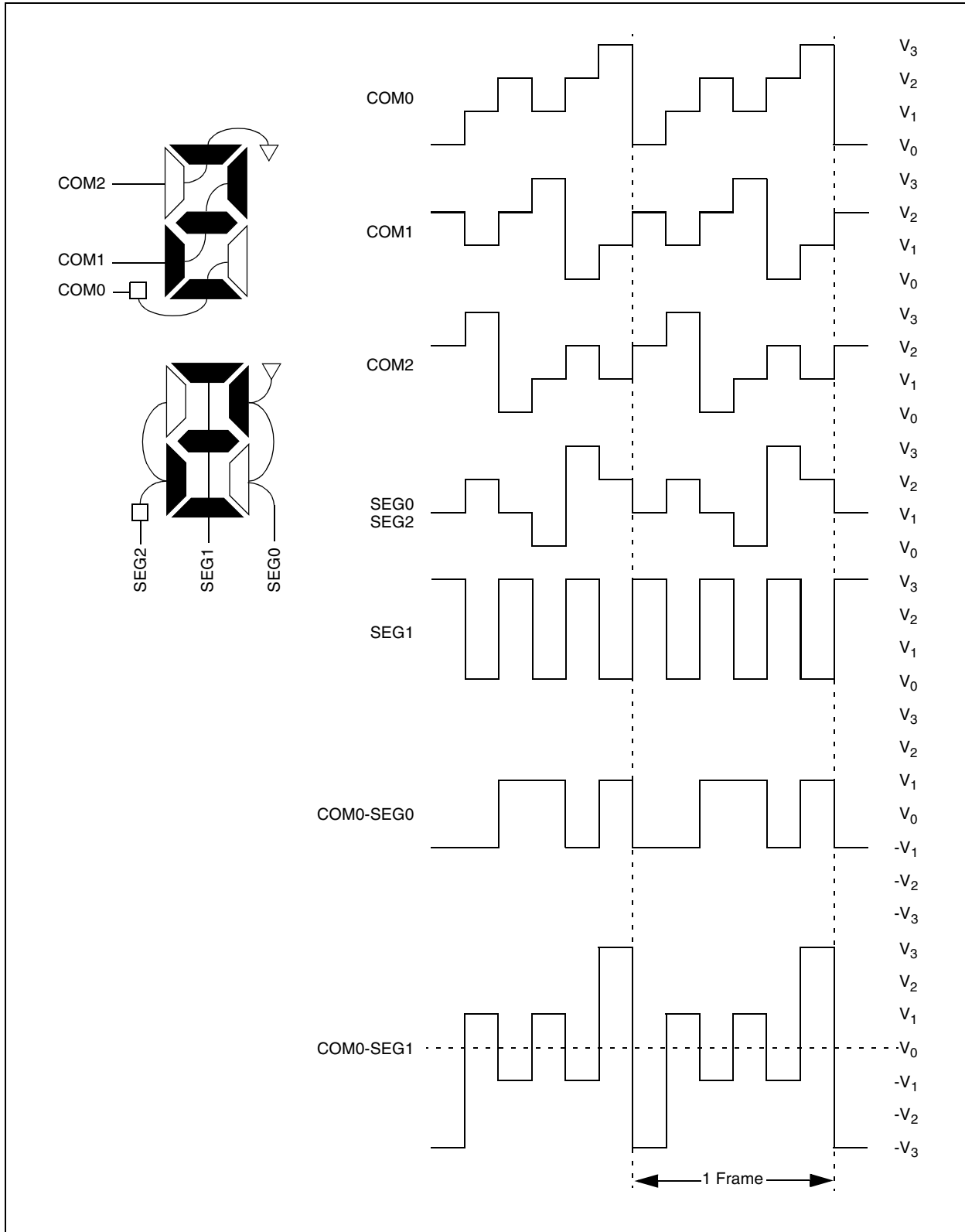

PIC18F85J90 FAMILY

FIGURE 15-14: TYPE-B WAVEFORMS IN 1/3 MUX, 1/3 BIAS DRIVE

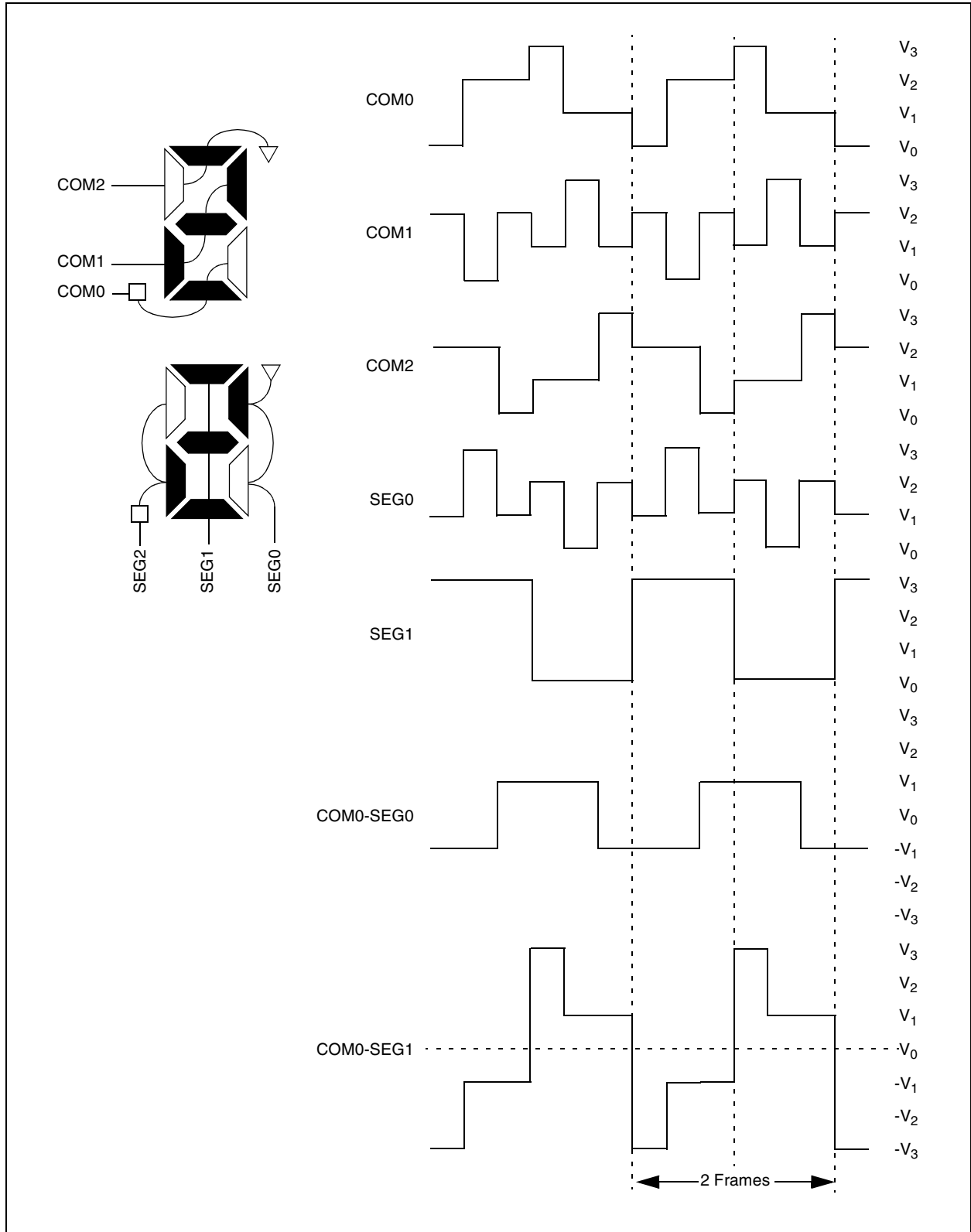

PIC18F85J90 FAMILY

FIGURE 15-15: TYPE-A WAVEFORMS IN 1/4 MUX, 1/3 BIAS DRIVE

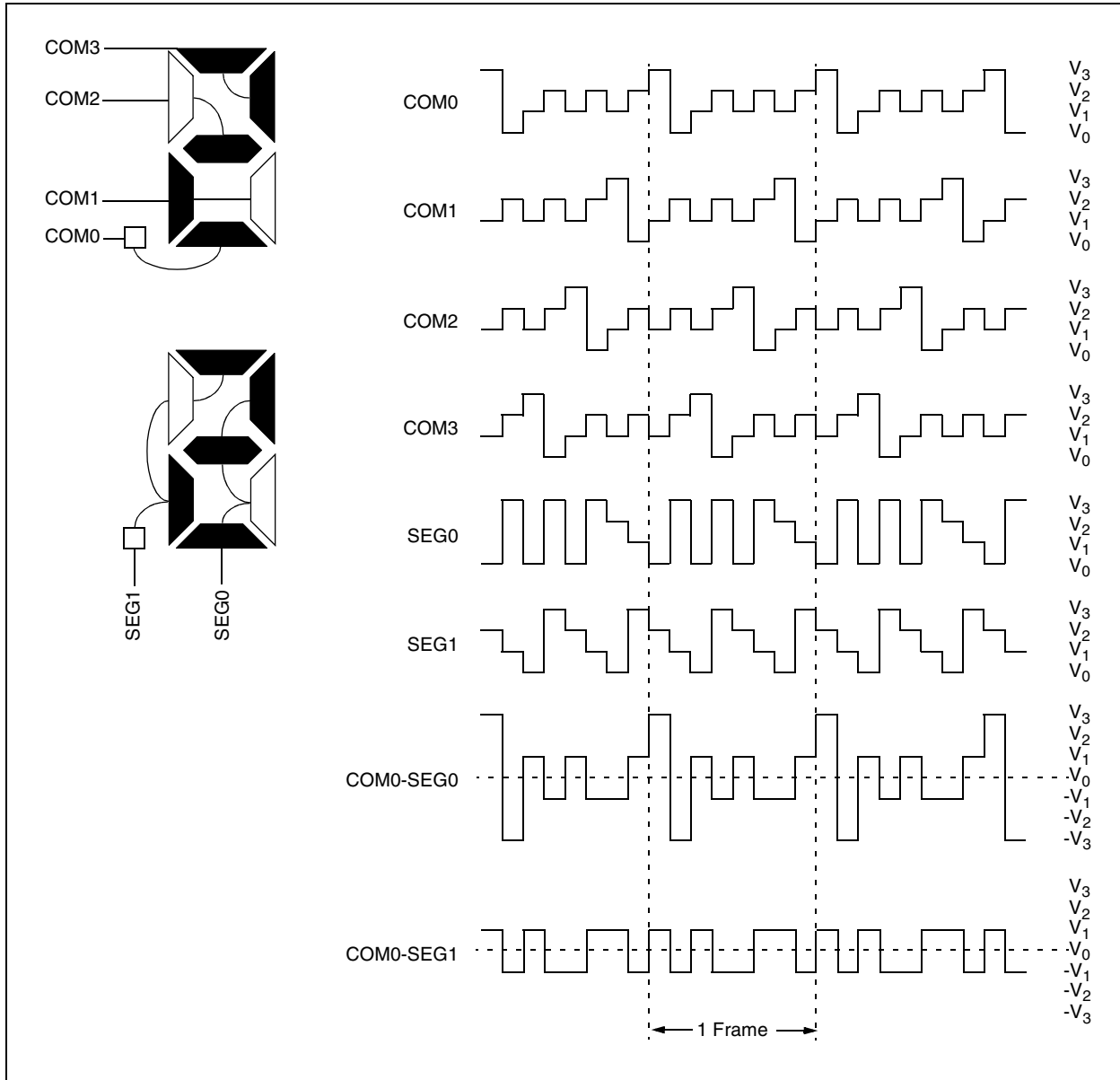

PIC18F85J90 FAMILY

FIGURE 15-16: TYPE-B WAVEFORMS IN 1/4 MUX, 1/3 BIAS DRIVE

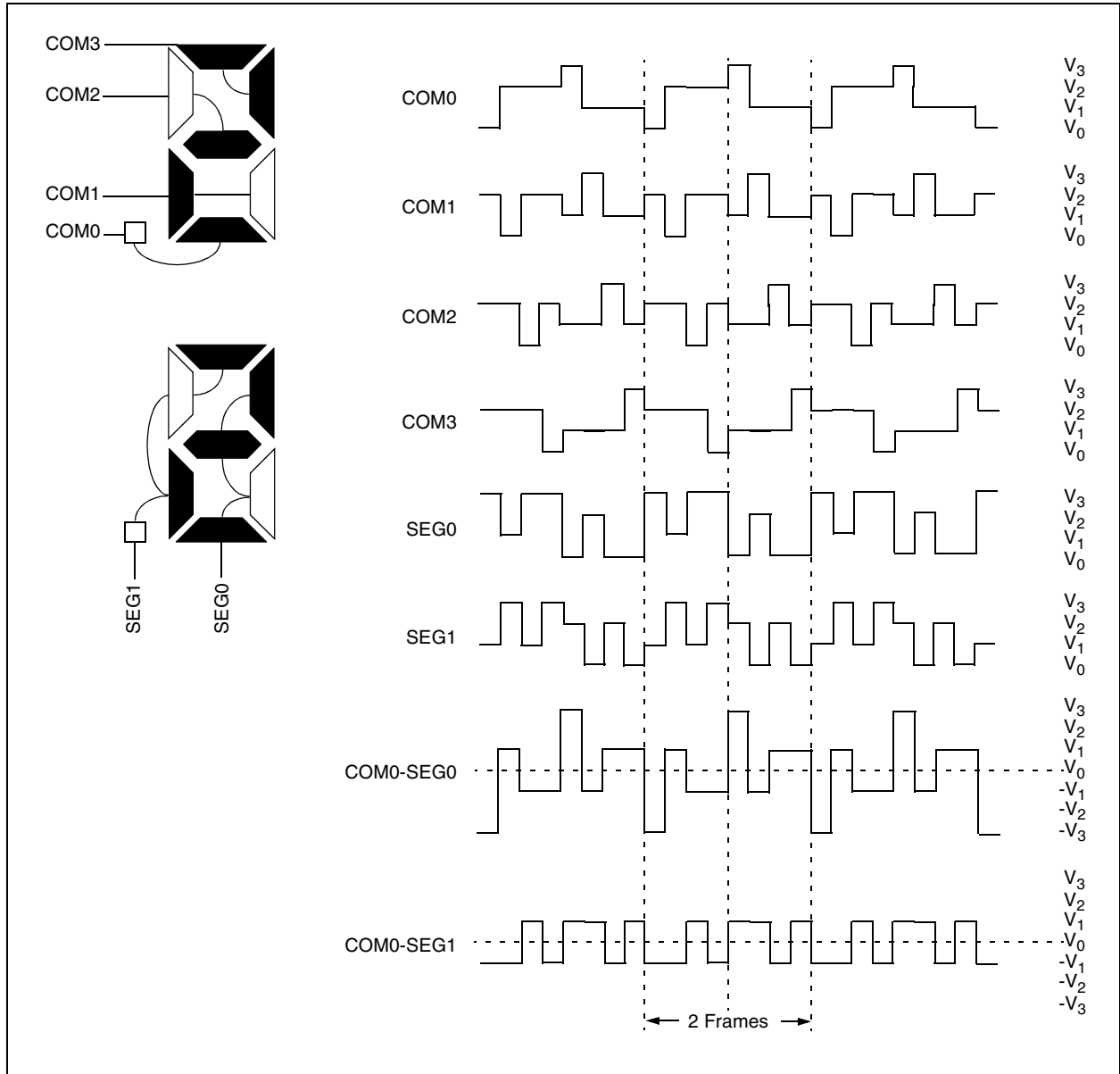

PIC18F85J90 FAMILY

15.9 LCD Interrupts

The LCD timing generation provides an interrupt that defines the LCD frame timing. This interrupt can be used to coordinate the writing of the pixel data with the start of a new frame. Writing pixel data at the frame boundary allows a visually crisp transition of the image. This interrupt can also be used to synchronize external events to the LCD. For example, the interface to an external segment driver can be synchronized for segment data update to the LCD frame.

A new frame is defined to begin at the leading edge of the COM0 common signal. The interrupt will be set immediately after the LCD controller completes accessing all pixel data required for a frame. This will occur at a fixed interval before the frame boundary (TFINT), as shown in Figure 15-17. The LCD controller will begin to access data for the next frame within the interval from the interrupt to when the controller begins to access data after the interrupt (TFWR). New data must be written within TFWR, as this is when the LCD controller will begin to access the data for the next frame.

When the LCD driver is running with Type-B waveforms, and the LMUX1:LMUX0 bits are not equal to '00', there are some additional issues that must be addressed. Since the DC voltage on the pixel takes two frames to maintain zero volts, the pixel data must not change between subsequent frames. If the pixel data were allowed to change, the waveform for the odd frames would not necessarily be the complement of the waveform generated in the even frames and a DC component would be introduced into the panel. Therefore, when using Type-B waveforms, the user must synchronize the LCD pixel updates to occur within a subframe after the frame interrupt.

To correctly sequence writing while in Type-B, the interrupt will only occur on complete phase intervals. If the user attempts to write when the write is disabled, the WERR (LCDCON<5>) bit is set.

Note: The interrupt is not generated when the Type-A waveform is selected and when the Type-B with no multiplex (static) is selected.

FIGURE 15-17: EXAMPLE WAVEFORMS AND INTERRUPT TIMING IN QUARTER DUTY CYCLE DRIVE

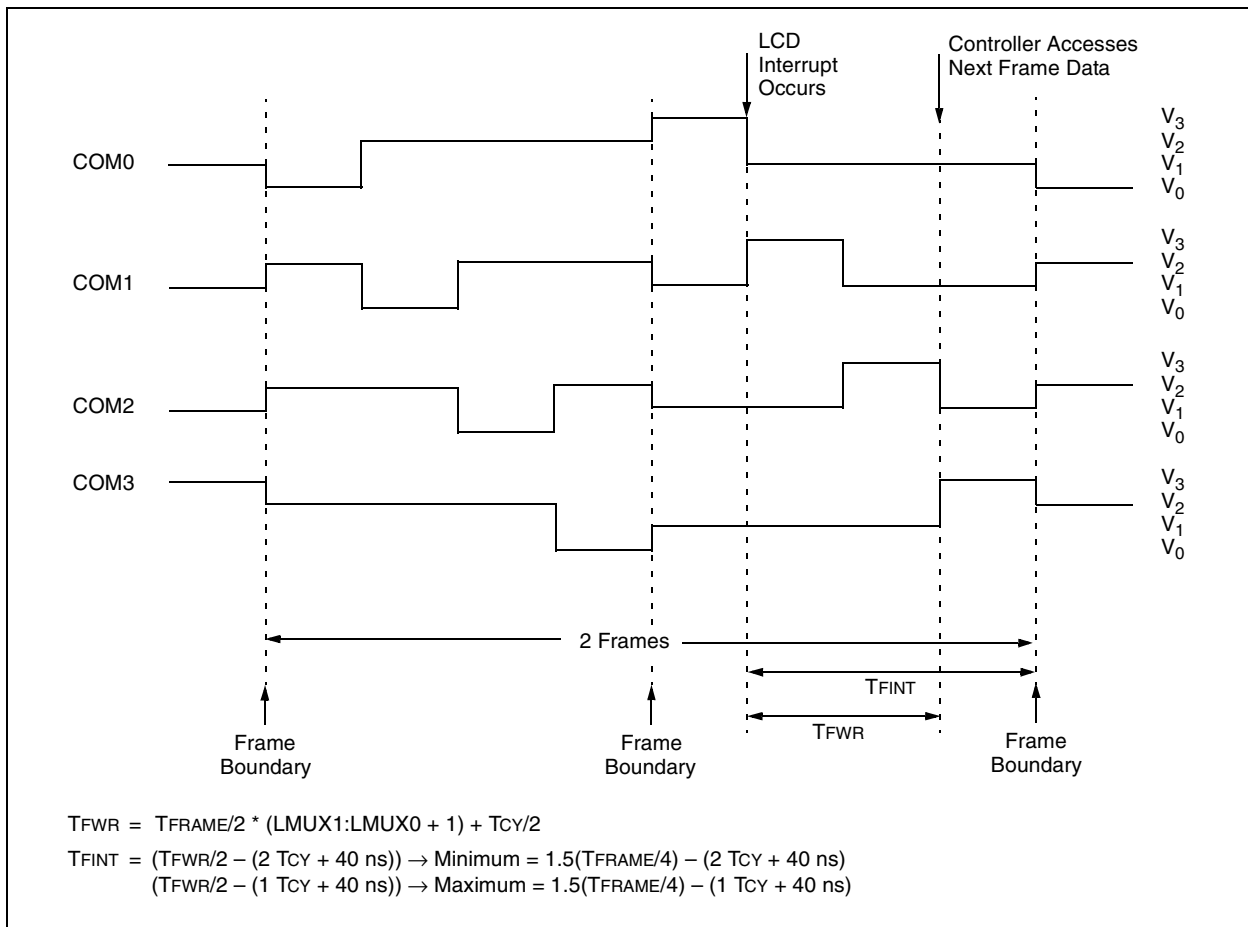

15.10 Operation During Sleep

The LCD module can operate during Sleep. The selection is controlled by the SLPEN bit (LCDCON<6>). Setting the SLPEN bit allows the LCD module to go to Sleep. Clearing the SLPEN bit allows the module to continue to operate during Sleep.

If a SLEEP instruction is executed and SLPEN = 1, the LCD module will cease all functions and go into a very low-current consumption mode. The module will stop operation immediately and drive the minimum LCD voltage on both segment and common lines. Figure 15-18 shows this operation.

To ensure that no DC component is introduced on the panel, the SLEEP instruction should be executed immediately after a LCD frame boundary. The LCD interrupt can be used to determine the frame boundary. See **Section 15.9 “LCD Interrupts”** for the formulas to calculate the delay.

If a SLEEP instruction is executed and SLPEN = 0, the module will continue to display the current contents of the LCDDATA registers. To allow the module to continue operation while in Sleep, the clock source must be either the Timer1 oscillator or one of the

internal oscillators (either INTRC or INTOSC as the default system clock). While in Sleep, the LCD data cannot be changed. The LCD module current consumption will not decrease in this mode; however, the overall consumption of the device will be lower due to shut down of the core and other peripheral functions.

If the system clock is selected and the module is not configured for Sleep operation, the module will ignore the SLPEN bit and stop operation immediately. The minimum LCD voltage will then be driven onto the segments and commons

15.10.1 USING THE LCD REGULATOR DURING SLEEP

Applications that use the LCD regulator for bias generation may not achieve the same degree of power reductions in Sleep mode when compared to applications using Mode 3 (resistor ladder) biasing. This is particularly true with Mode 0 operation, where the charge pump is active.

If Modes 0, 1 or 2 are used for bias generation, software contrast control will not be available.

FIGURE 15-18: SLEEP ENTRY/EXIT WHEN SLPEN = 1 OR CS1:CS0 = 00

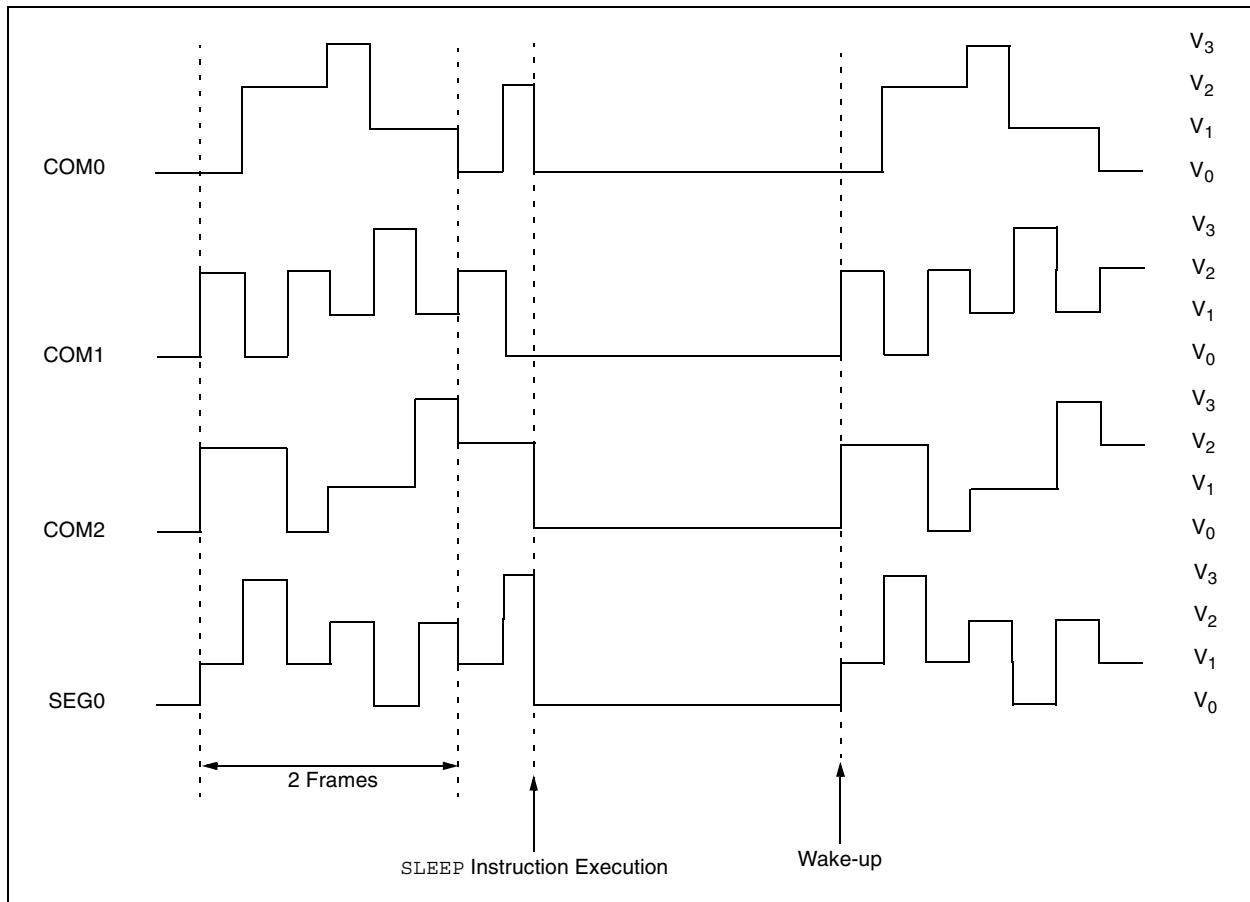

PIC18F85J90 FAMILY

15.11 Configuring the LCD Module

The following is the sequence of steps to configure the LCD module.

1. Select the frame clock prescale using bits LP3:LP0 (LCDPS<3:0>).
2. Configure the appropriate pins to function as segment drivers using the LCDSEx registers.
3. Configure the appropriate pins as inputs using TRISx registers.
4. Configure the LCD module for the following using the LCDCON register:
 - Multiplex and Bias mode (LMUX1:LMUX0)
 - Timing source (CS1:CS0)
 - Sleep mode (SLPEN)
5. Write initial values to pixel data registers, LCDDATA0 through LCDDATA23.
6. Configure the LCD Regulator:
 - a) If M2 or M3 bias configuration is to be used, turn off the regulator by setting CKSEL<1:0> (LCDREG<1:0>) to '00'. Set or clear the CPEN bit (LCDREG<6>) to select Mode 2 or Mode 3, as appropriate.
 - b) If M0 or M1 bias generation is to be used:
 - Set the VBIAS level using the BIAS<2:0> bits (LCDREG<5:3>).
 - Set or clear the CPEN bit to enable or disable the charge pump.
 - Set or clear the MODE13 bit (LCDREG<2>) to select the Bias mode.
 - Select a regulator clock source using the CKSEL<1:0> bits.
7. Clear LCD Interrupt Flag, LCDIF (PIR3<6>), and if desired, enable the interrupt by setting the LCDIE bit (PIE3<6>).
8. Enable the LCD module by setting the LCDEN bit (LCDCON<7>).

PIC18F85J90 FAMILY

TABLE 15-6: REGISTERS ASSOCIATED WITH LCD OPERATION

Name	Bit 7	Bit 6	Bit 5	Bit 4	Bit 3	Bit 2	Bit 1	Bit 0	Reset Values on Page
INTCON	GIE/GIEH	PEIE/GIEL	TMR0IE	INT0IE	RBIE	TMR0IF	INT0IF	RBIF	51
PIR3	—	LCDIF	RC2IF	TX2IF	—	CCP2IF	CCP1IF	—	54
PIE3	—	LCDIE	RC2IE	TX2IE	—	CCP2IE	CCP1IE	—	54
IPR3	—	LCDIP	RC2IP	TX2IP	—	CCP2IP	CCP1IP	—	54
RCON	IPEN	—	—	RI	TO	PD	POR	BOR	52
LCDDATA23 ⁽¹⁾	S47C3	S46C3	S45C3	S44C3	S43C3	S42C3	S41C3	S40C3	55
LCDDATA22	S39C3 ⁽¹⁾	S38C3 ⁽¹⁾	S37C3 ⁽¹⁾	S36C3 ⁽¹⁾	S35C3 ⁽¹⁾	S34C3 ⁽¹⁾	S33C3 ⁽¹⁾	S32C3	55
LCDDATA21	S31C3	S30C3	S29C3	S28C3	S27C3	S26C3	S25C3	S24C3	55
LCDDATA20	S23C3	S22C3	S21C3	S20C3	S19C3	S18C3	S17C3	S16C3	55
LCDDATA19	S15C3	S14C3	S13C3	S12C3	S11C3	S10C3	S09C3	S08C3	55
LCDDATA18	S07C3	S06C3	S05C3	S04C3	S03C3	S02C3	S01C3	S00C3	55
LCDDATA17 ⁽¹⁾	S47C2	S46C2	S45C2	S44C2	S43C2	S42C2	S41C2	S40C2	55
LCDDATA16	S39C2 ⁽¹⁾	S38C2 ⁽¹⁾	S37C2 ⁽¹⁾	S36C2 ⁽¹⁾	S35C2 ⁽¹⁾	S34C2 ⁽¹⁾	S33C2 ⁽¹⁾	S32C2	55
LCDDATA15	S31C2	S30C2	S29C2	S28C2	S27C2	S26C2	S25C2	S24C2	55
LCDDATA14	S23C2	S22C2	S21C2	S20C2	S19C2	S18C2	S17C2	S16C2	55
LCDDATA13	S15C2	S14C2	S13C2	S12C2	S11C2	S10C2	S09C2	S08C2	55
LCDDATA12	S07C2	S06C2	S05C2	S04C2	S03C2	S02C2	S01C2	S00C2	55
LCDDATA11 ⁽¹⁾	S47C1	S46C1	S45C1	S44C1	S43C1	S42C1	S41C1	S40C1	55
LCDDATA10	S39C1 ⁽¹⁾	S38C1 ⁽¹⁾	S37C1 ⁽¹⁾	S36C1 ⁽¹⁾	S35C1 ⁽¹⁾	S34C1 ⁽¹⁾	S33C1 ⁽¹⁾	S32C1	55
LCDDATA9	S31C1	S30C1	S29C1	S28C1	S27C1	S26C1	S25C1	S24C1	55
LCDDATA8	S23C1	S22C1	S21C1	S20C1	S19C1	S18C1	S17C1	S16C1	55
LCDDATA7	S15C1	S14C1	S13C1	S12C1	S11C1	S10C1	S09C1	S08C1	55
LCDDATA6	S07C1	S06C1	S05C1	S04C1	S03C1	S02C1	S01C1	S00C1	55
LCDDATA5 ⁽¹⁾	S47C0	S46C0	S45C0	S44C0	S43C0	S42C0	S41C0	S40C0	55
LCDDATA4	S39C0 ⁽¹⁾	S38C0 ⁽¹⁾	S37C0 ⁽¹⁾	S36C0 ⁽¹⁾	S35C0 ⁽¹⁾	S34C0 ⁽¹⁾	S33C0 ⁽¹⁾	S32C0	53
LCDDATA3	S31C0	S30C0	S29C0	S28C0	S27C0	S26C0	S25C0	S24C0	53
LCDDATA2	S23C0	S22C0	S21C0	S20C0	S19C0	S18C0	S17C0	S16C0	53
LCDDATA1	S15C0	S14C0	S13C0	S12C0	S11C0	S10C0	S09C0	S08C0	53
LCDDATA0	S07C0	S06C0	S05C0	S04C0	S03C0	S02C0	S01C0	S00C0	53
LCDSE5 ⁽¹⁾	SE47	SE46	SE45	SE44	SE43	SE42	SE41	SE40	53
LCDSE4	SE39 ⁽¹⁾	SE38 ⁽¹⁾	SE37 ⁽¹⁾	SE36 ⁽¹⁾	SE35 ⁽¹⁾	SE34 ⁽¹⁾	SE33 ⁽¹⁾	SE32	53
LCDSE3	SE31	SE30	SE29	SE28	SE27	SE26	SE25	SE24	53
LCDSE2	SE23	SE22	SE21	SE20	SE19	SE18	SE17	SE16	53
LCDSE1	SE15	SE14	SE13	SE12	SE11	SE10	SE09	SE08	53
LCDSE0	SE07	SE06	SE05	SE04	SE03	SE02	SE01	SE00	53
LCDCON	LCDEN	SLPEN	WERR	—	CS1	CS0	LMUX1	LMUX0	53
LCDPS	WFT	BIASMD	LCD A	WA	LP3	LP2	LP1	LP0	53
LCDREG	—	CPEN	BIAS2	BIAS1	BIAS0	MODE13	CKSEL1	CKSEL0	

Legend: — = unimplemented, read as '0'. Shaded cells are not used for LCD operation.

Note 1: These registers or individual bits are unimplemented on 64-pin devices.

PIC18F85J90 FAMILY

NOTES:

16.0 MASTER SYNCHRONOUS SERIAL PORT (MSSP) MODULE

16.1 Master SSP (MSSP) Module Overview

The Master Synchronous Serial Port (MSSP) module is a serial interface, useful for communicating with other peripheral or microcontroller devices. These peripheral devices may be serial EEPROMs, shift registers, display drivers, A/D converters, etc. The MSSP module can operate in one of two modes:

- Serial Peripheral Interface (SPI)
- Inter-Integrated Circuit (I²C™)
 - Full Master mode
 - Slave mode (with general address call)

The I²C interface supports the following modes in hardware:

- Master mode
- Multi-Master mode
- Slave mode

16.2 Control Registers

Each MSSP module has three associated control registers. These include a status register (SSPSTAT) and two control registers (SSPCON1 and SSPCON2). The use of these registers and their individual bits differ significantly depending on whether the MSSP module is operated in SPI or I²C mode.

Additional details are provided under the individual sections.

16.3 SPI Mode

The SPI mode allows 8 bits of data to be synchronously transmitted and received simultaneously. All four modes of SPI are supported. To accomplish communication, typically three pins are used:

- Serial Data Out (SDO) – RC5/SDO
- Serial Data In (SDI) – RC4/SDI/SDA
- Serial Clock (SCK) – RC3/SCK/SCL

Additionally, a fourth pin may be used when in a Slave mode of operation:

- Slave Select (\overline{SS}) – RF7/ \overline{SS}

Figure 16-1 shows the block diagram of the MSSP module when operating in SPI mode.

FIGURE 16-1: MSSP BLOCK DIAGRAM (SPI MODE)

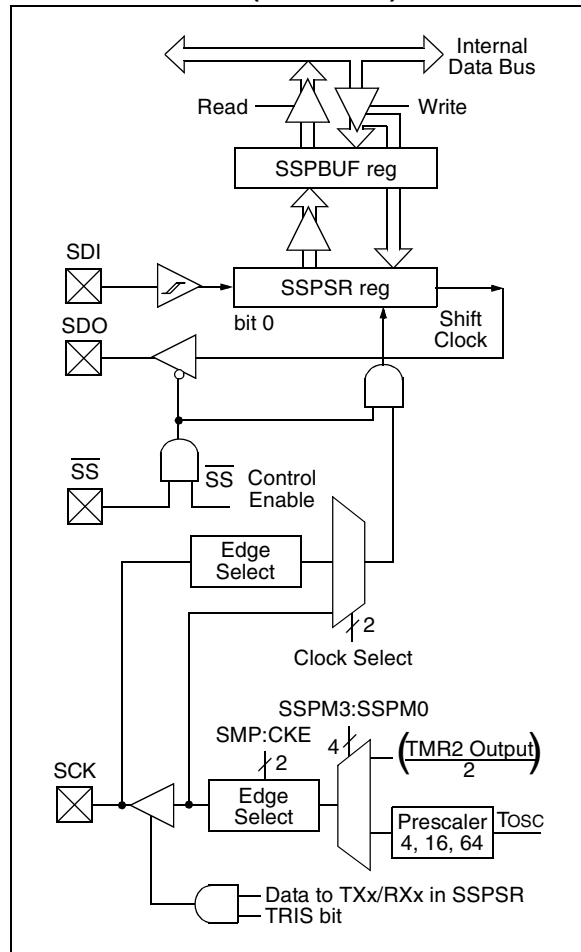

PIC18F85J90 FAMILY

16.3.1 REGISTERS

Each MSSP module has four registers for SPI mode operation. These are:

- MSSP Control Register 1 (SSPCON1)
- MSSP Status Register (SSPSTAT)
- Serial Receive/Transmit Buffer Register (SSPBUF)
- MSSP Shift Register (SSPSR) – Not directly accessible

SSPCON1 and SSPSTAT are the control and status registers in SPI mode operation. The SSPCON1 register is readable and writable. The lower 6 bits of the SSPSTAT are read-only. The upper two bits of the SSPSTAT are read/write.

SSPSR is the shift register used for shifting data in or out. SSPBUF is the buffer register to which data bytes are written to or read from.

In receive operations, SSPSR and SSPBUF together create a double-buffered receiver. When SSPSR receives a complete byte, it is transferred to SSPBUF and the SSPIF interrupt is set.

During transmission, the SSPBUF is not double-buffered. A write to SSPBUF will write to both SSPBUF and SSPSR.

REGISTER 16-1: SSPSTAT: MSSP STATUS REGISTER (SPI MODE)

R/W-0	R/W-0	R-0	R-0	R-0	R-0	R0	R-0
SMP	CKE ⁽¹⁾	D/A	P	S	R/W	UA	BF
bit 7							bit 0

Legend:

R = Readable bit	W = Writable bit	U = Unimplemented bit, read as '0'
-n = Value at POR	'1' = Bit is set	'0' = Bit is cleared
		x = Bit is unknown

- bit 7 **SMP:** Sample bit
SPI Master mode:
 1 = Input data sampled at end of data output time
 0 = Input data sampled at middle of data output time
SPI Slave mode:
 SMP must be cleared when SPI is used in Slave mode.
- bit 6 **CKE:** SPI Clock Select bit⁽¹⁾
 1 = Transmit occurs on transition from active to Idle clock state
 0 = Transmit occurs on transition from Idle to active clock state
- bit 5 **D/A:** Data/Address bit
 Used in I²C™ mode only.
- bit 4 **P:** Stop bit
 Used in I²C mode only. This bit is cleared when the MSSP module is disabled, SSPEN is cleared.
- bit 3 **S:** Start bit
 Used in I²C mode only.
- bit 2 **R/W:** Read/Write Information bit
 Used in I²C mode only.
- bit 1 **UA:** Update Address bit
 Used in I²C mode only.
- bit 0 **BF:** Buffer Full Status bit (Receive mode only)
 1 = Receive complete, SSPBUF is full
 0 = Receive not complete, SSPBUF is empty

Note 1: Polarity of clock state is set by the CKP bit (SSPCON1<4>).

PIC18F85J90 FAMILY

REGISTER 16-2: SSPCON1: MSSP CONTROL REGISTER 1 (SPI MODE)

R/W-0	R/W-0	R/W-0	R/W-0	R/W-0	R/W-0	R/W-0	R/W-0
WCOL	SSPOV ⁽¹⁾	SSPEN ⁽²⁾	CKP	SSPM3 ⁽³⁾	SSPM2 ⁽³⁾	SSPM1 ⁽³⁾	SSPM0 ⁽³⁾
bit 7							bit 0

Legend:

R = Readable bit	W = Writable bit	U = Unimplemented bit, read as '0'
-n = Value at POR	'1' = Bit is set	'0' = Bit is cleared
		x = Bit is unknown

- bit 7 **WCOL:** Write Collision Detect bit (Transmit mode only)
 1 = The SSPBUF register is written while it is still transmitting the previous word (must be cleared in software)
 0 = No collision
- bit 6 **SSPOV:** Receive Overflow Indicator bit⁽¹⁾
SPI Slave mode:
 1 = A new byte is received while the SSPBUF register is still holding the previous data. In case of overflow, the data in SSPSR is lost. Overflow can only occur in Slave mode. The user must read the SSPBUF, even if only transmitting data, to avoid setting overflow (must be cleared in software).
 0 = No overflow
- bit 5 **SSPEN:** Master Synchronous Serial Port Enable bit⁽²⁾
 1 = Enables serial port and configures SCK, SDO, SDI and \overline{SS} as serial port pins
 0 = Disables serial port and configures these pins as I/O port pins
- bit 4 **CKP:** Clock Polarity Select bit
 1 = Idle state for clock is a high level
 0 = Idle state for clock is a low level
- bit 3-0 **SSPM3:SSPM0:** Master Synchronous Serial Port Mode Select bits⁽³⁾
 0101 = SPI Slave mode, clock = SCK pin, \overline{SS} pin control disabled, \overline{SS} can be used as I/O pin
 0100 = SPI Slave mode, clock = SCK pin, \overline{SS} pin control enabled
 0011 = SPI Master mode, clock = TMR2 output/2
 0010 = SPI Master mode, clock = Fosc/64
 0001 = SPI Master mode, clock = Fosc/16
 0000 = SPI Master mode, clock = Fosc/4

- Note 1:** In Master mode, the overflow bit is not set since each new reception (and transmission) is initiated by writing to the SSPBUF register.
- 2:** When enabled, these pins must be properly configured as input or output.
- 3:** Bit combinations not specifically listed here are either reserved or implemented in I²C™ mode only.

PIC18F85J90 FAMILY

16.3.2 OPERATION

When initializing the SPI, several options need to be specified. This is done by programming the appropriate control bits (SSPCON1<5:0> and SSPSTAT<7:6>). These control bits allow the following to be specified:

- Master mode (SCK is the clock output)
- Slave mode (SCK is the clock input)
- Clock Polarity (Idle state of SCK)
- Data Input Sample Phase (middle or end of data output time)
- Clock Edge (output data on rising/falling edge of SCK)
- Clock Rate (Master mode only)
- Slave Select mode (Slave mode only)

Each MSSP consists of a transmit/receive shift register (SSPSR) and a buffer register (SSPBUF). The SSPSR shifts the data in and out of the device, MSb first. The SSPBUF holds the data that was written to the SSPSR until the received data is ready. Once the 8 bits of data have been received, that byte is moved to the SSPBUF register. Then, the Buffer Full detect bit, BF (SSPSTAT<0>), and the interrupt flag bit, SSPIF, are set. This double-buffering of the received data (SSPBUF) allows the next byte to start reception before

reading the data that was just received. Any write to the SSPBUF register during transmission/reception of data will be ignored and the Write Collision detect bit, WCOL (SSPCON1<7>), will be set. User software must clear the WCOL bit so that it can be determined if the following write(s) to the SSPBUF register completed successfully.

When the application software is expecting to receive valid data, the SSPBUF should be read before the next byte of data to transfer is written to the SSPBUF. The Buffer Full bit, BF (SSPSTAT<0>), indicates when SSPBUF has been loaded with the received data (transmission is complete). When the SSPBUF is read, the BF bit is cleared. This data may be irrelevant if the SPI is only a transmitter. Generally, the MSSP interrupt is used to determine when the transmission/reception has completed. The SSPBUF must be read and/or written. If the interrupt method is not going to be used, then software polling can be done to ensure that a write collision does not occur. Example 16-1 shows the loading of the SSPBUF (SSPSR) for data transmission.

The SSPSR is not directly readable or writable and can only be accessed by addressing the SSPBUF register. Additionally, the SSPSTAT register indicates the various status conditions.

EXAMPLE 16-1: LOADING THE SSPBUF (SSPSR) REGISTER

LOOP	BTFSS	SSPSTAT, BF	;Has data been received (transmit complete)?
	BRA	LOOP	;No
	MOVF	SSPBUF, W	;WREG reg = contents of SSPBUF
	MOVWF	RXDATA	;Save in user RAM, if data is meaningful
	MOVF	TXDATA, W	;W reg = contents of TXDATA
	MOVWF	SSPBUF	;New data to xmit

PIC18F85J90 FAMILY

16.3.3 ENABLING SPI I/O

To enable the serial port, MSSP Enable bit, SSPEN (SSPCON1<5>), must be set. To reset or reconfigure SPI mode, clear the SSPEN bit, reinitialize the SSPCON registers and then set the SSPEN bit. This configures the SDI, SDO, SCK and \overline{SS} pins as serial port pins. For the pins to behave as the serial port function, some must have their data direction bits (in the TRIS register) appropriately programmed as follows:

- SDI is automatically controlled by the SPI module
- SDO must have TRISC<5> bit cleared
- SCK (Master mode) must have TRISC<3> bit cleared
- SCK (Slave mode) must have TRISC<3> bit set
- \overline{SS} must have TRISF<7> bit set

Any serial port function that is not desired may be overridden by programming the corresponding data direction (TRIS) register to the opposite value.

16.3.4 OPEN-DRAIN OUTPUT OPTION

The drivers for the SDO output and SCK clock pins can be optionally configured as open-drain outputs. This feature allows the voltage level on the pin to be pulled

to a higher level through an external pull-up resistor, and allows the output to communicate with external circuits without the need for additional level shifters.

The open-drain output option is controlled by the SPOD bit (TRISG<7>). Setting the bit configures both pins for open-drain operation.

16.3.5 TYPICAL CONNECTION

Figure 16-2 shows a typical connection between two microcontrollers. The master controller (Processor 1) initiates the data transfer by sending the SCK signal. Data is shifted out of both shift registers on their programmed clock edge and latched on the opposite edge of the clock. Both processors should be programmed to the same Clock Polarity (CKP), then both controllers would send and receive data at the same time. Whether the data is meaningful (or dummy data) depends on the application software. This leads to three scenarios for data transmission:

- Master sends data – Slave sends dummy data
- Master sends data – Slave sends data
- Master sends dummy data – Slave sends data

FIGURE 16-2: SPI MASTER/SLAVE CONNECTION

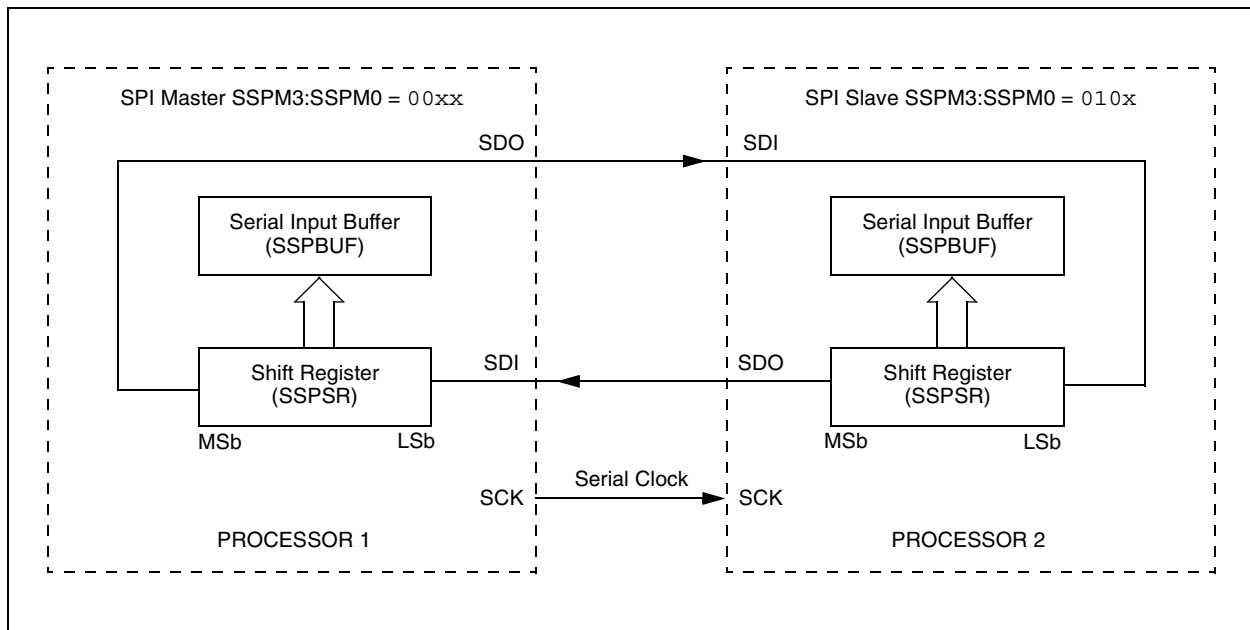

PIC18F85J90 FAMILY

16.3.6 MASTER MODE

The master can initiate the data transfer at any time because it controls the SCK. The master determines when the slave (Processor 2, Figure 16-2) will broadcast data by the software protocol.

In Master mode, the data is transmitted/received as soon as the SSPBUF register is written to. If the SPI is only going to receive, the SDO output could be disabled (programmed as an input). The SSPSR register will continue to shift in the signal present on the SDI pin at the programmed clock rate. As each byte is received, it will be loaded into the SSPBUF register as if a normal received byte (interrupts and status bits appropriately set). This could be useful in receiver applications as a "Line Activity Monitor" mode.

The clock polarity is selected by appropriately programming the CKP bit (SSPCON1<4>). This, then, would give waveforms for SPI communication as shown in Figure 16-3, Figure 16-5 and Figure 16-6, where the MSB is transmitted first. In Master mode, the SPI clock rate (bit rate) is user-programmable to be one of the following:

- $F_{osc}/4$ (or T_{CY})
- $F_{osc}/16$ (or $4 \cdot T_{CY}$)
- $F_{osc}/64$ (or $16 \cdot T_{CY}$)
- $Timer2\ output/2$

This allows a maximum data rate (at 40 MHz) of 10.00 Mbps.

Figure 16-3 shows the waveforms for Master mode. When the CKE bit is set, the SDO data is valid before there is a clock edge on SCK. The change of the input sample is shown based on the state of the SMP bit. The time when the SSPBUF is loaded with the received data is shown.

FIGURE 16-3: SPI MODE WAVEFORM (MASTER MODE)

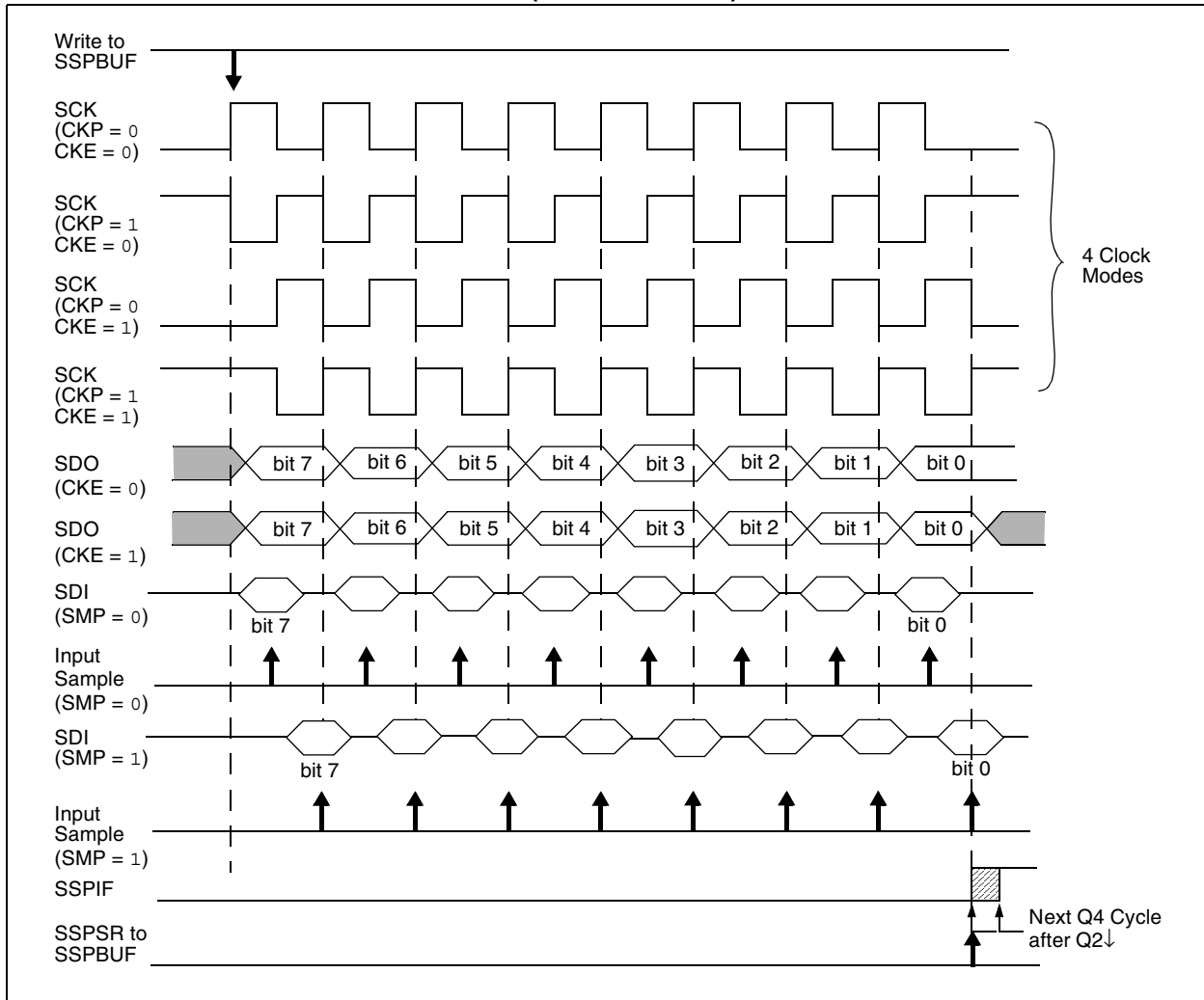

16.3.7 SLAVE MODE

In Slave mode, the data is transmitted and received as the external clock pulses appear on SCK. When the last bit is latched, the SSPIF interrupt flag bit is set.

Before enabling the module in SPI Slave mode, the clock line must match the proper Idle state. The clock line can be observed by reading the SCK pin. The Idle state is determined by the CKP bit (SSPCON1<4>).

While in Slave mode, the external clock is supplied by the external clock source on the SCK pin. This external clock must meet the minimum high and low times as specified in the electrical specifications.

While in Sleep mode, the slave can transmit/receive data. When a byte is received, the device will wake-up from Sleep.

16.3.8 SLAVE SELECT SYNCHRONIZATION

The \overline{SS} pin allows a Synchronous Slave mode. The SPI must be in Slave mode with \overline{SS} pin control enabled (SSPCON1<3:0> = 04h). When the \overline{SS} pin is low, transmission and reception are enabled and the SDO pin is

driven. When the \overline{SS} pin goes high, the SDO pin is no longer driven, even if in the middle of a transmitted byte and becomes a floating output. External pull-up/pull-down resistors may be desirable depending on the application.

- Note 1:** When the SPI is in Slave mode with \overline{SS} pin control enabled (SSPCON1<3:0> = 0100), the SPI module will reset if the \overline{SS} pin is set to VDD.
- 2:** If the SPI is used in Slave mode with CKE set, then the \overline{SS} pin control must be enabled.

When the SPI module resets, the bit counter is forced to '0'. This can be done by either forcing the \overline{SS} pin to a high level or clearing the SSPEN bit.

To emulate two-wire communication, the SDO pin can be connected to the SDI pin. When the SPI needs to operate as a receiver, the SDO pin can be configured as an input. This disables transmissions from the SDO. The SDI can always be left as an input (SDI function) since it cannot create a bus conflict.

FIGURE 16-4: SLAVE SYNCHRONIZATION WAVEFORM

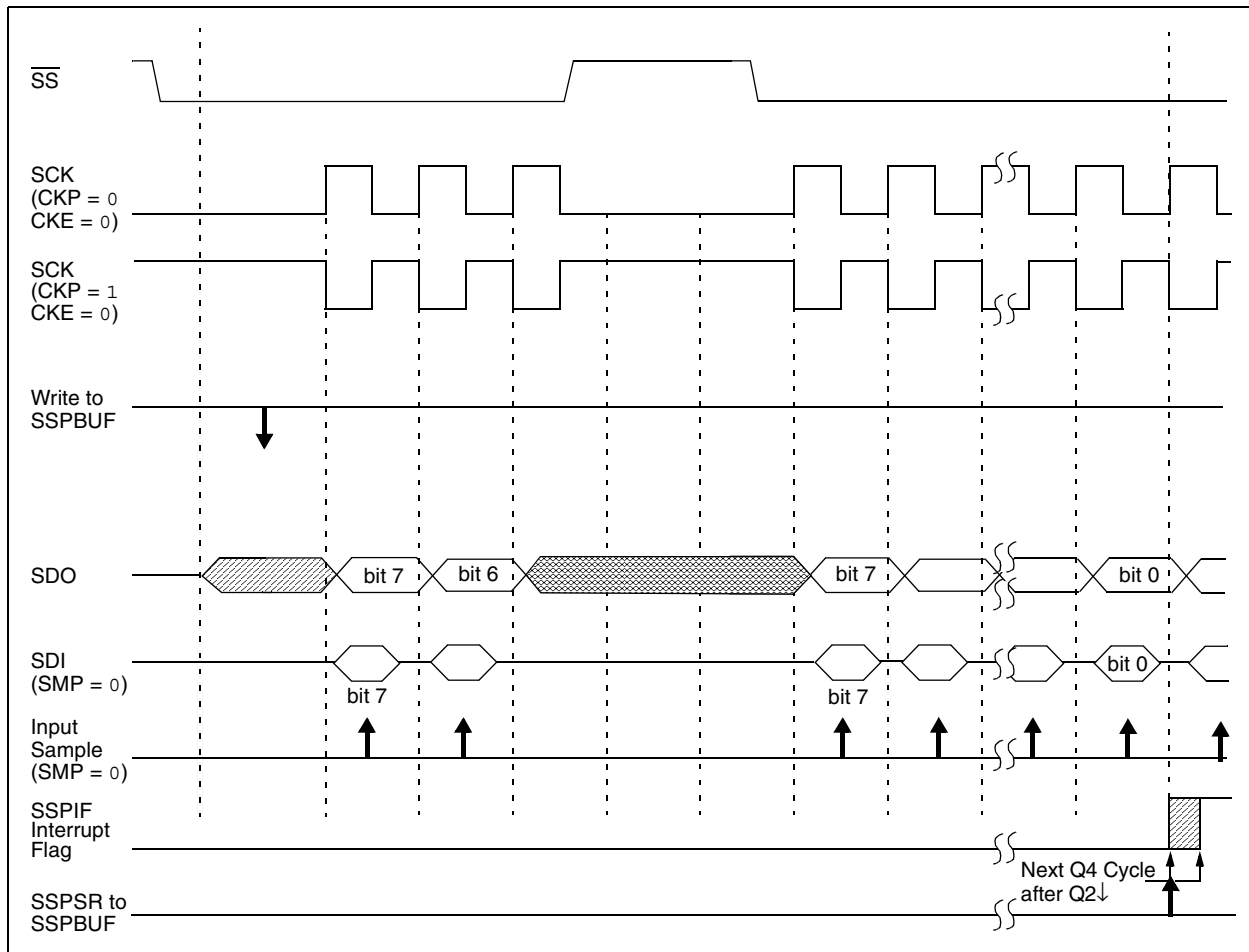

PIC18F85J90 FAMILY

FIGURE 16-5: SPI MODE WAVEFORM (SLAVE MODE WITH CKE = 0)

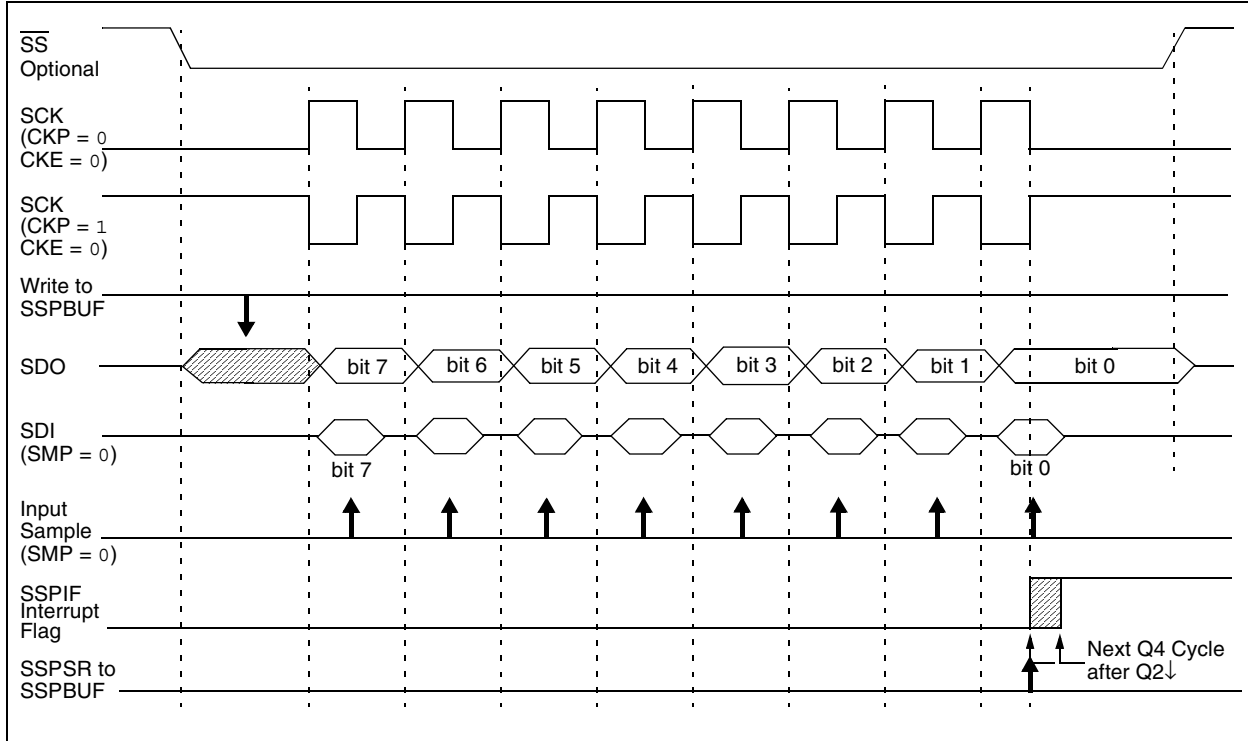
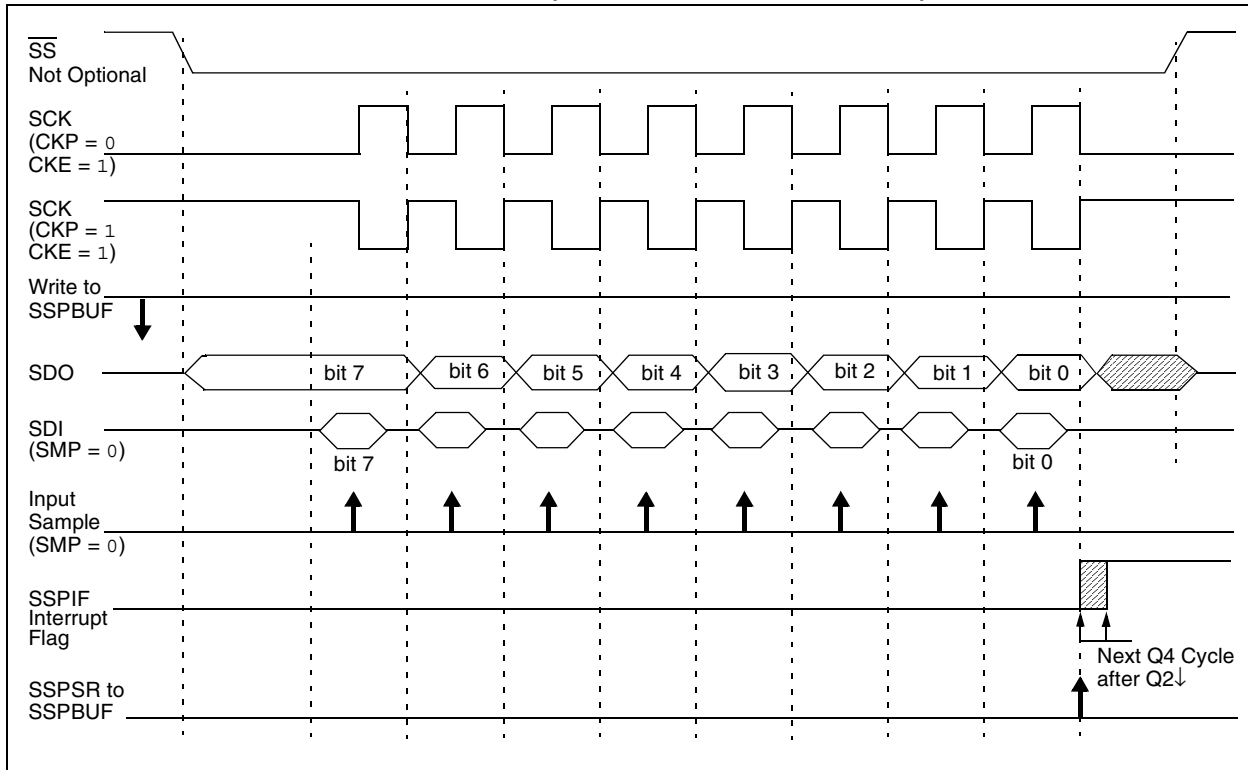

FIGURE 16-6: SPI MODE WAVEFORM (SLAVE MODE WITH CKE = 1)



PIC18F85J90 FAMILY

16.3.9 OPERATION IN POWER-MANAGED MODES

In SPI Master mode, module clocks may be operating at a different speed than when in Full Power mode; in the case of Sleep mode, all clocks are halted.

In Idle modes, a clock is provided to the peripherals. That clock should be from the primary clock source, the secondary clock (Timer1 oscillator at 32.768 kHz) or the INTRC source. See **Section 2.3 “Clock Sources and Oscillator Switching”** for additional information.

In most cases, the speed that the master clocks SPI data is not important; however, this should be evaluated for each system.

If MSSP interrupts are enabled, they can wake the controller from Sleep mode, or one of the Idle modes, when the master completes sending data. If an exit from Sleep or Idle mode is not desired, MSSP interrupts should be disabled.

If the Sleep mode is selected, all module clocks are halted and the transmission/reception will remain in that state until the device wakes. After the device returns to Run mode, the module will resume transmitting and receiving data.

In SPI Slave mode, the SPI Transmit/Receive Shift register operates asynchronously to the device. This allows the device to be placed in any power-managed

mode and data to be shifted into the SPI Transmit/Receive Shift register. When all 8 bits have been received, the MSSP interrupt flag bit will be set and if enabled, will wake the device.

16.3.10 EFFECTS OF A RESET

A Reset disables the MSSP module and terminates the current transfer.

16.3.11 BUS MODE COMPATIBILITY

Table 16-1 shows the compatibility between the standard SPI modes and the states of the CKP and CKE control bits.

TABLE 16-1: SPI BUS MODES

Standard SPI Mode Terminology	Control Bits State	
	CKP	CKE
0, 0	0	1
0, 1	0	0
1, 0	1	1
1, 1	1	0

There is also an SMP bit which controls when the data is sampled.

TABLE 16-2: REGISTERS ASSOCIATED WITH SPI OPERATION

Name	Bit 7	Bit 6	Bit 5	Bit 4	Bit 3	Bit 2	Bit 1	Bit 0	Reset Values on page
INTCON	GIE/GIEH	PEIE/GIEL	TMR0IE	INT0IE	RBIE	TMR0IF	INT0IF	RBIF	51
PIR1	—	ADIF	RC1IF	TX1IF	SSPIF	—	TMR2IF	TMR1IF	54
PIE1	—	ADIE	RC1IE	TX1IE	SSPIE	—	TMR2IE	TMR1IE	54
IPR1	—	ADIP	RC1IP	TX1IP	SSPIP	—	TMR2IP	TMR1IP	54
TRISC	TRISC7	TRISC6	TRISC5	TRISC4	TRISC3	TRISC2	TRISC1	TRISC0	54
TRISF	TRISF7	TRISF6	TRISF5	TRISF4	TRISF3	TRISF2	TRISF1	—	54
TRISG	SPIOD	CCP2OD	CCP1OD	TRISG4	TRISG3	TRISG2	TRISG1	TRISG0	54
SSPBUF	MSSP Receive Buffer/Transmit Register								52
SSPCON1	WCOL	SSPOV	SSPEN	CKP	SSPM3	SSPM2	SSPM1	SSPM0	52
SSPSTAT	SMP	CKE	D/Ā	P	S	R/Ā	UA	BF	52

Legend: Shaded cells are not used by the MSSP module in SPI mode.

PIC18F85J90 FAMILY

16.4 I²C Mode

The MSSP module in I²C mode fully implements all master and slave functions (including general call support) and provides interrupts on Start and Stop bits in hardware to determine a free bus (multi-master function). The MSSP module implements the standard mode specifications as well as 7-bit and 10-bit addressing.

Two pins are used for data transfer:

- Serial clock (SCL) – RC3/SCK/SCL
- Serial data (SDA) – RC4/SDI/SDA

The user must configure these pins as inputs by setting the TRISC<4:3> bits.

FIGURE 16-7: MSSP BLOCK DIAGRAM (I²C™ MODE)

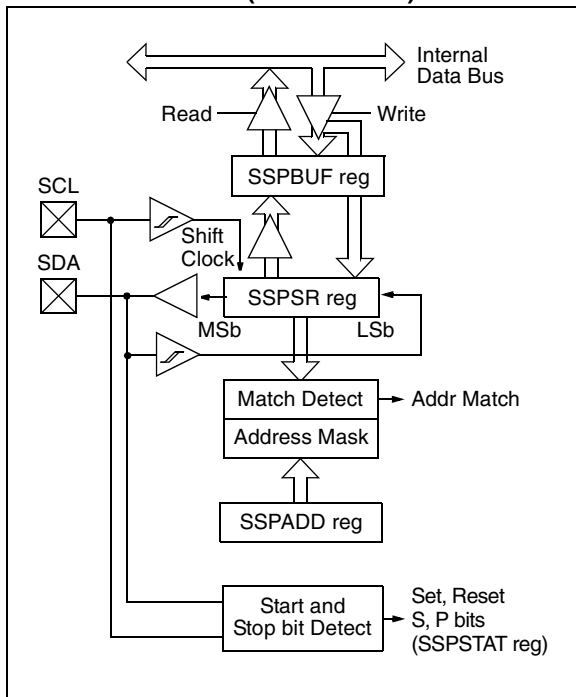

16.4.1 REGISTERS

The MSSP module has six registers for I²C operation. These are:

- MSSP Control Register 1 (SSPCON1)
- MSSP Control Register 2 (SSPCON2)
- MSSP Status Register (SSPSTAT)
- Serial Receive/Transmit Buffer Register (SSPBUF)
- MSSP Shift Register (SSPSR) – Not directly accessible
- MSSP Address Register (SSPADD)

SSPCON1, SSPCON2 and SSPSTAT are the control and status registers in I²C mode operation. The SSPCON1 and SSPCON2 registers are readable and writable. The lower 6 bits of the SSPSTAT are read-only. The upper two bits of the SSPSTAT are read/write.

Many of the bits in SSPCON2 assume different functions, depending on whether the module is operating in Master or Slave mode; bits <5:2> also assume different names in Slave mode. The different aspects of SSPCON2 are shown in Register 16-5 (for Master mode) and Register 16-6 (Slave mode).

SSPSR is the shift register used for shifting data in or out. SSPBUF is the buffer register to which data bytes are written to or read from.

SSPADD register holds the slave device address when the MSSP is configured in I²C Slave mode. When the MSSP is configured in Master mode, the lower seven bits of SSPADD act as the Baud Rate Generator reload value.

In receive operations, SSPSR and SSPBUF together create a double-buffered receiver. When SSPSR receives a complete byte, it is transferred to SSPBUF and the SSPIF interrupt is set.

During transmission, the SSPBUF is not double-buffered. A write to SSPBUF will write to both SSPBUF and SSPSR.

PIC18F85J90 FAMILY

REGISTER 16-3: SSPSTAT: MSSP STATUS REGISTER (I²C™ MODE)

R/W-0	R/W-0	R-0	R-0	R-0	R-0	R0	R-0
SMP	CKE	D/ \bar{A}	P ⁽¹⁾	S ⁽¹⁾	R/ \bar{W}	UA	BF
bit 7						bit 0	

Legend:

R = Readable bit	W = Writable bit	U = Unimplemented bit, read as '0'
-n = Value at POR	'1' = Bit is set	'0' = Bit is cleared
		x = Bit is unknown

- bit 7 **SMP:** Slew Rate Control bit
In Master or Slave mode:
 1 = Slew rate control disabled for Standard Speed mode (100 kHz and 1 MHz)
 0 = Slew rate control enabled for High-Speed mode (400 kHz)
- bit 6 **CKE:** SMBus Select bit
In Master or Slave mode:
 1 = Enable SMBus specific inputs
 0 = Disable SMBus specific inputs
- bit 5 **D/ \bar{A} :** Data/Address bit
In Master mode:
 Reserved.
In Slave mode:
 1 = Indicates that the last byte received or transmitted was data
 0 = Indicates that the last byte received or transmitted was address
- bit 4 **P:** Stop bit⁽¹⁾
 1 = Indicates that a Stop bit has been detected last
 0 = Stop bit was not detected last
- bit 3 **S:** Start bit⁽¹⁾
 1 = Indicates that a Start bit has been detected last
 0 = Start bit was not detected last
- bit 2 **R/ \bar{W} :** Read/Write Information bit (I²C mode only)
In Slave mode:⁽²⁾
 1 = Read
 0 = Write
In Master mode:⁽³⁾
 1 = Transmit is in progress
 0 = Transmit is not in progress
- bit 1 **UA:** Update Address bit (10-Bit Slave mode only)
 1 = Indicates that the user needs to update the address in the SSPADD register
 0 = Address does not need to be updated
- bit 0 **BF:** Buffer Full Status bit
In Transmit mode:
 1 = SSPBUF is full
 0 = SSPBUF is empty
In Receive mode:
 1 = SSPBUF is full (does not include the \bar{ACK} and Stop bits)
 0 = SSPBUF is empty (does not include the \bar{ACK} and Stop bits)

- Note 1:** This bit is cleared on Reset and when SSPEN is cleared.
- 2:** This bit holds the R/ \bar{W} bit information following the last address match. This bit is only valid from the address match to the next Start bit, Stop bit or not \bar{ACK} bit.
- 3:** ORing this bit with SEN, RSEN, PEN, RCEN or ACKEN will indicate if the MSSP is in Active mode.

PIC18F85J90 FAMILY

REGISTER 16-4: SSPCON1: MSSP CONTROL REGISTER 1 (I²C™ MODE)

R/W-0	R/W-0	R/W-0	R/W-0	R/W-0	R/W-0	R/W-0	R/W-0
WCOL	SSPOV	SSPEN ⁽¹⁾	CKP	SSPM3	SSPM2	SSPM1	SSPM0
bit 7							bit 0

Legend:

R = Readable bit
-n = Value at POR

W = Writable bit
'1' = Bit is set

U = Unimplemented bit, read as '0'
'0' = Bit is cleared
x = Bit is unknown

- bit 7 **WCOL:** Write Collision Detect bit
In Master Transmit mode:
 1 = A write to the SSPBUF register was attempted while the I²C conditions were not valid for a transmission to be started (must be cleared in software)
 0 = No collision
In Slave Transmit mode:
 1 = The SSPBUF register is written while it is still transmitting the previous word (must be cleared in software)
 0 = No collision
In Receive mode (Master or Slave modes):
 This is a "don't care" bit.
- bit 6 **SSPOV:** Receive Overflow Indicator bit
In Receive mode:
 1 = A byte is received while the SSPBUF register is still holding the previous byte (must be cleared in software)
 0 = No overflow
In Transmit mode:
 This is a "don't care" bit in Transmit mode.
- bit 5 **SSPEN:** Master Synchronous Serial Port Enable bit⁽¹⁾
 1 = Enables the serial port and configures the SDA and SCL pins as the serial port pins
 0 = Disables serial port and configures these pins as I/O port pins
- bit 4 **CKP:** SCK Release Control bit
In Slave mode:
 1 = Release clock
 0 = Holds clock low (clock stretch), used to ensure data setup time
In Master mode:
 Unused in this mode.
- bit 3-0 **SSPM3:SSPM0:** Synchronous Serial Port Mode Select bits
 1111 = I²C Slave mode, 10-bit address with Start and Stop bit interrupts enabled
 1110 = I²C Slave mode, 7-bit address with Start and Stop bit interrupts enabled
 1011 = I²C Firmware Controlled Master mode (slave Idle)
 1000 = I²C Master mode, clock = FOSC/(4 * (SSPADD + 1))
 0111 = I²C Slave mode, 10-bit address
 0110 = I²C Slave mode, 7-bit address
 Bit combinations not specifically listed here are either reserved or implemented in SPI mode only.

Note 1: When enabled, the SDA and SCL pins must be configured as inputs.

PIC18F85J90 FAMILY

REGISTER 16-5: SSPCON2: MSSP CONTROL REGISTER 2 (I²C™ MASTER MODE)

R/W-0	R/W-0	R/W-0	R/W-0	R/W-0	R/W-0	R/W-0	R/W-0
GCEN	ACKSTAT	ACKDT ⁽¹⁾	ACKEN ⁽²⁾	RCEN ⁽²⁾	PEN ⁽²⁾	RSEN ⁽²⁾	SEN ⁽²⁾
bit 7							bit 0

Legend:

R = Readable bit	W = Writable bit	U = Unimplemented bit, read as '0'
-n = Value at POR	'1' = Bit is set	'0' = Bit is cleared
		x = Bit is unknown

- bit 7 **GCEN:** General Call Enable bit
Unused in Master mode.
- bit 6 **ACKSTAT:** Acknowledge Status bit (Master Transmit mode only)
1 = Acknowledge was not received from slave
0 = Acknowledge was received from slave
- bit 5 **ACKDT:** Acknowledge Data bit (Master Receive mode only)⁽¹⁾
1 = Not Acknowledge
0 = Acknowledge
- bit 4 **ACKEN:** Acknowledge Sequence Enable bit⁽²⁾
1 = Initiate Acknowledge sequence on SDA and SCL pins and transmit ACKDT data bit. Automatically cleared by hardware.
0 = Acknowledge sequence Idle
- bit 3 **RCEN:** Receive Enable bit (Master Receive mode only)⁽²⁾
1 = Enables Receive mode for I²C
0 = Receive Idle
- bit 2 **PEN:** Stop Condition Enable bit⁽²⁾
1 = Initiate Stop condition on SDA and SCL pins. Automatically cleared by hardware.
0 = Stop condition Idle
- bit 1 **RSEN:** Repeated Start Condition Enable bit⁽²⁾
1 = Initiate Repeated Start condition on SDA and SCL pins. Automatically cleared by hardware.
0 = Repeated Start condition Idle
- bit 0 **SEN:** Start Condition Enable bit⁽²⁾
1 = Initiate Start condition on SDA and SCL pins. Automatically cleared by hardware.
0 = Start condition Idle

- Note 1:** Value that will be transmitted when the user initiates an Acknowledge sequence at the end of a receive.
- Note 2:** If the I²C module is active, these bits may not be set (no spooling) and the SSPBUF may not be written (or writes to the SSPBUF are disabled).

PIC18F85J90 FAMILY

REGISTER 16-6: SSPCON2: MSSP CONTROL REGISTER 2 (I²C™ SLAVE MODE)

R/W-0	R/W-0	R/W-0	R/W-0	R/W-0	R/W-0	R/W-0	R/W-0
GCEN	ACKSTAT	ADMSK5	ADMSK4	ADMSK3	ADMSK2	ADMSK1	SEN ⁽¹⁾
bit 7							bit 0

Legend:

R = Readable bit	W = Writable bit	U = Unimplemented bit, read as '0'
-n = Value at POR	'1' = Bit is set	'0' = Bit is cleared x = Bit is unknown

- bit 7 **GCEN:** General Call Enable bit
 1 = Enable interrupt when a general call address (0000h) is received in the SSPSR
 0 = General call address disabled
- bit 6 **ACKSTAT:** Acknowledge Status bit
 Unused in Slave mode.
- bit 5-2 **ADMSK5:ADMSK2:** Slave Address Mask Select bits
 1 = Masking of corresponding bits of SSPADD enabled
 0 = Masking of corresponding bits of SSPADD disabled
- bit 1 **ADMSK1:** Slave Address Least Significant bit(s) Mask Select bit
In 7-Bit Address mode:
 1 = Masking of SSPADD<1> only enabled
 0 = Masking of SSPADD<1> only disabled
In 10-Bit Address mode:
 1 = Masking of SSPADD<1:0> enabled
 0 = Masking of SSPADD<1:0> disabled
- bit 0 **SEN:** Stretch Enable bit⁽¹⁾
 1 = Clock stretching is enabled for both slave transmit and slave receive (stretch enabled)
 0 = Clock stretching is disabled

Note 1: If the I²C module is active, this bit may not be set (no spooling) and the SSPBUF may not be written (or writes to the SSPBUF are disabled).

16.4.2 OPERATION

The MSSP module functions are enabled by setting the MSSP Enable bit, SSPEN (SSPCON1<5>).

The SSPCON1 register allows control of the I²C operation. Four mode selection bits (SSPCON1<3:0>) allow one of the following I²C modes to be selected:

- I²C Master mode,
clock = (Fosc/4) x (SSPADD + 1)
- I²C Slave mode (7-bit address)
- I²C Slave mode (10-bit address)
- I²C Slave mode (7-bit address) with Start and Stop bit interrupts enabled
- I²C Slave mode (10-bit address) with Start and Stop bit interrupts enabled
- I²C Firmware Controlled Master mode,
slave is Idle

Selection of any I²C mode, with the SSPEN bit set, forces the SCL and SDA pins to be open-drain, provided these pins are programmed to inputs by setting the appropriate TRISC or TRISD bits. To ensure proper operation of the module, pull-up resistors must be provided externally to the SCL and SDA pins.

16.4.3 SLAVE MODE

In Slave mode, the SCL and SDA pins must be configured as inputs (TRISC<4:3> set). The MSSP module will override the input state with the output data when required (slave-transmitter).

The I²C Slave mode hardware will always generate an interrupt on an exact address match. In addition, address masking will also allow the hardware to generate an interrupt for more than one address (up to 31 in 7-bit addressing and up to 63 in 10-bit addressing). Through the mode select bits, the user can also choose to interrupt on Start and Stop bits.

When an address is matched, or the data transfer after an address match is received, the hardware automatically will generate the Acknowledge (ACK) pulse and load the SSPBUF register with the received value currently in the SSPSR register.

Any combination of the following conditions will cause the MSSP module not to give this ACK pulse:

- The Buffer Full bit, BF (SSPSTAT<0>), was set before the transfer was received.
- The overflow bit, SSPOV (SSPCON1<6>), was set before the transfer was received.

In this case, the SSPSR register value is not loaded into the SSPBUF, but bit SSPIF is set. The BF bit is cleared by reading the SSPBUF register, while bit SSPOV is cleared through software.

The SCL clock input must have a minimum high and low for proper operation. The high and low times of the I²C specification, as well as the requirement of the MSSP module, are shown in timing parameter 100 and parameter 101.

16.4.3.1 Addressing

Once the MSSP module has been enabled, it waits for a Start condition to occur. Following the Start condition, the 8 bits are shifted into the SSPSR register. All incoming bits are sampled with the rising edge of the clock (SCL) line. The value of register SSPSR<7:1> is compared to the value of the SSPADD register. The address is compared on the falling edge of the eighth clock (SCL) pulse. If the addresses match and the BF and SSPOV bits are clear, the following events occur:

1. The SSPSR register value is loaded into the SSPBUF register.
2. The Buffer Full bit, BF, is set.
3. An ACK pulse is generated.
4. The MSSP Interrupt Flag bit, SSPIF, is set (and interrupt is generated, if enabled) on the falling edge of the ninth SCL pulse.

In 10-Bit Address mode, two address bytes need to be received by the slave. The five Most Significant bits (MSBs) of the first address byte specify if this is a 10-bit address. Bit R/W (SSPSTAT<2>) must specify a write so the slave device will receive the second address byte. For a 10-bit address, the first byte would equal '11110 A₉ A₈ 0', where 'A₉' and 'A₈' are the two MSBs of the address. The sequence of events for 10-bit address is as follows, with steps 7 through 9 for the slave-transmitter:

1. Receive first (high) byte of address (bits SSPIF, BF and UA (SSPSTAT<1>) are set).
2. Update the SSPADD register with second (low) byte of address (clears bit UA and releases the SCL line).
3. Read the SSPBUF register (clears bit BF) and clear flag bit, SSPIF.
4. Receive second (low) byte of address (SSPIF, BF and UA bits are set).
5. Update the SSPADD register with the first (high) byte of address. If match releases SCL line, this will clear UA bit.
6. Read the SSPBUF register (clears bit BF) and clear flag bit, SSPIF.
7. Receive Repeated Start condition.
8. Receive first (high) byte of address (SSPIF and BF bits are set).
9. Read the SSPBUF register (clears BF bit) and clear flag bit, SSPIF.

PIC18F85J90 FAMILY

16.4.3.2 Address Masking

Masking an address bit causes that bit to become a “don’t care”. When one address bit is masked, two addresses will be Acknowledged and cause an interrupt. It is possible to mask more than one address bit at a time, which makes it possible to Acknowledge up to 31 addresses in 7-bit mode and up to 63 addresses in 10-bit mode (see Example 16-2).

The I²C Slave behaves the same way whether address masking is used or not. However, when address masking is used, the I²C slave can Acknowledge multiple addresses and cause interrupts. When this occurs, it is necessary to determine which address caused the interrupt by checking SSPBUF.

In 7-Bit Address mode, address mask bits, ADMSK<5:1> (SSPCON<5:1>), mask the corresponding address bits in the SSPADD register. For any ADMSK bits that are set (ADMSK<n> = 1), the corresponding address bit is ignored (SSPADD<n> = x). For the module to issue an address Acknowledge, it is sufficient to match only on addresses that do not have an active address mask.

In 10-Bit Address mode, ADMSK<5:2> bits mask the corresponding address bits in the SSPADD register. In addition, ADMSK1 simultaneously masks the two LSBs of the address (SSPADD<1:0>). For any ADMSK bits that are active (ADMSK<n> = 1), the corresponding address bit is ignored (SSPADD<n> = x). Also note that although in 10-Bit Addressing mode, the upper address bits reuse part of the SSPADD register bits, the address mask bits do not interact with those bits. They only affect the lower address bits.

Note 1: ADMSK1 masks the two Least Significant bits of the address.

2: The two Most Significant bits of the address are not affected by address masking.

EXAMPLE 16-2: ADDRESS MASKING EXAMPLES

7-Bit Addressing:

SSPADD<7:1> = A0h (1010000) (SSPADD<0> is assumed to be '0')

ADMSK<5:1> = 00111

Addresses Acknowledged: A0h, A2h, A4h, A6h, A8h, AAh, ACh, AEh

10-Bit Addressing:

SSPADD<7:0> = A0h (10100000) (the two MSBs of the address are ignored in this example, since they are not affected by masking)

ADMSK<5:1> = 00111

Addresses Acknowledged: A0h, A1h, A2h, A3h, A4h, A5h, A6h, A7h, A8h, A9h, AAh, ABh, ACh, ADh, AEh, AFh

16.4.3.3 Reception

When the $\overline{R/W}$ bit of the address byte is clear and an address match occurs, the $\overline{R/W}$ bit of the SSPSTAT register is cleared. The received address is loaded into the SSPBUF register and the SDA line is held low (\overline{ACK}).

When the address byte overflow condition exists, then the no Acknowledge (\overline{ACK}) pulse is given. An overflow condition is defined as either bit, BF (SSPSTAT<0>), is set or bit, SSPOV (SSPCON1<6>), is set.

An MSSP interrupt is generated for each data transfer byte. The interrupt flag bit, SSPIF, must be cleared in software. The SSPSTAT register is used to determine the status of the byte.

If SEN is enabled (SSPCON2<0> = 1), SCK/SCL will be held low (clock stretch) following each data transfer. The clock must be released by setting bit, CKP (SSPCON1<4>). See **Section 16.4.4 “Clock Stretching”** for more details.

16.4.3.4 Transmission

When the $\overline{R/W}$ bit of the incoming address byte is set and an address match occurs, the $\overline{R/W}$ bit of the SSPSTAT register is set. The received address is loaded into the SSPBUF register. The \overline{ACK} pulse will be sent on the ninth bit and pin RC3 is held low, regardless of SEN (see **Section 16.4.4 “Clock Stretching”** for more details). By stretching the clock, the master will be unable to assert another clock pulse until the slave is done preparing the transmit data. The transmit data must be loaded into the SSPBUF register which also loads the SSPSR register. Then, pin RC3 should be enabled by setting bit, CKP (SSPCON1<4>). The eight data bits are shifted out on the falling edge of the SCL input. This ensures that the SDA signal is valid during the SCL high time (Figure 16-10).

The \overline{ACK} pulse from the master-receiver is latched on the rising edge of the ninth SCL input pulse. If the SDA line is high (not \overline{ACK}), then the data transfer is complete. In this case, when the \overline{ACK} is latched by the slave, the slave logic is reset (resets SSPSTAT register) and the slave monitors for another occurrence of the Start bit. If the SDA line was low (\overline{ACK}), the next transmit data must be loaded into the SSPBUF register. Again, pin RC3 must be enabled by setting bit, CKP.

An MSSP interrupt is generated for each data transfer byte. The SSPIF bit must be cleared in software and the SSPSTAT register is used to determine the status of the byte. The SSPIF bit is set on the falling edge of the ninth clock pulse.

PIC18F85J90 FAMILY

FIGURE 16-8: I²C™ SLAVE MODE TIMING WITH SEN = 0 (RECEPTION, 7-BIT ADDRESS)

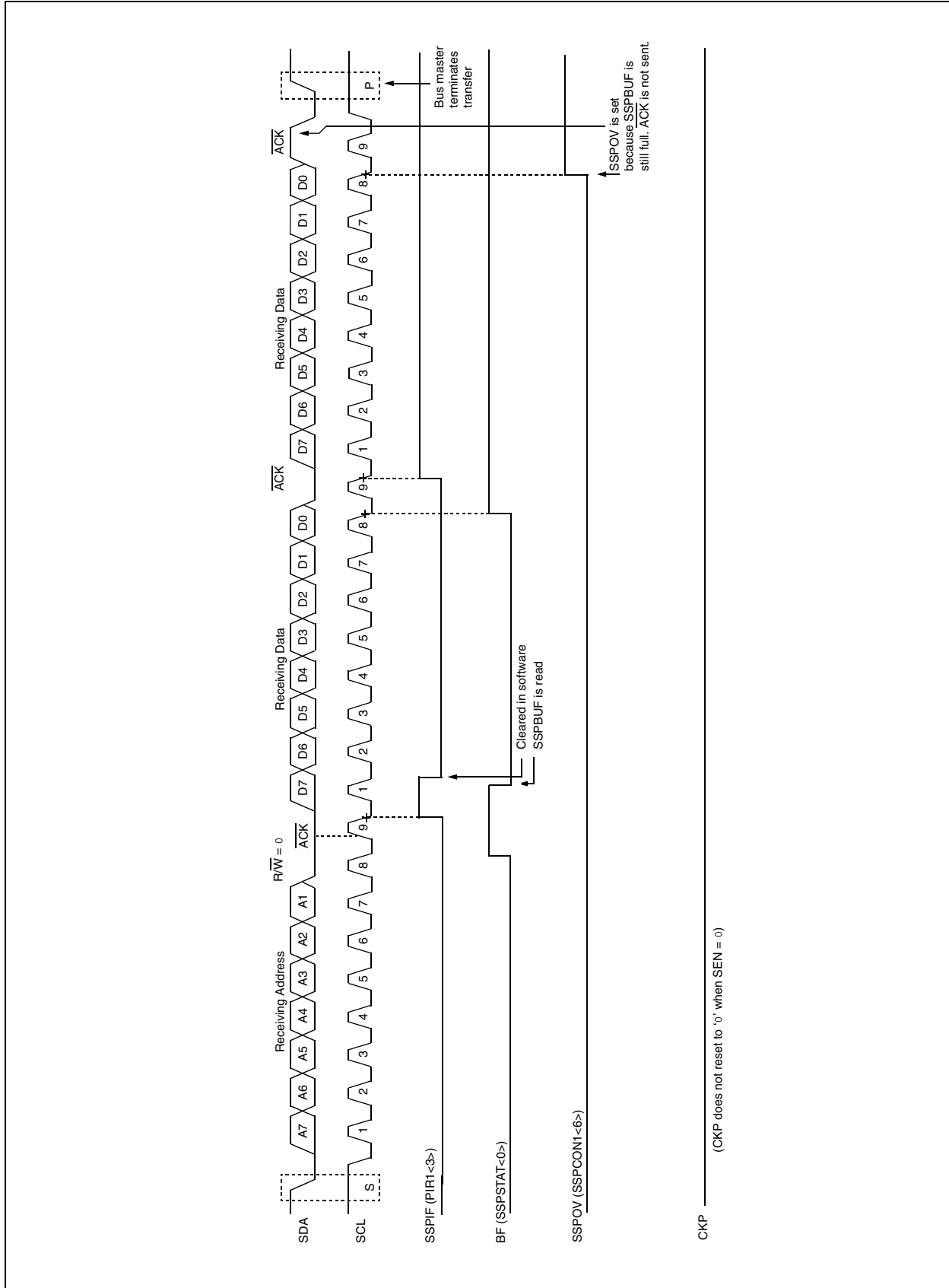
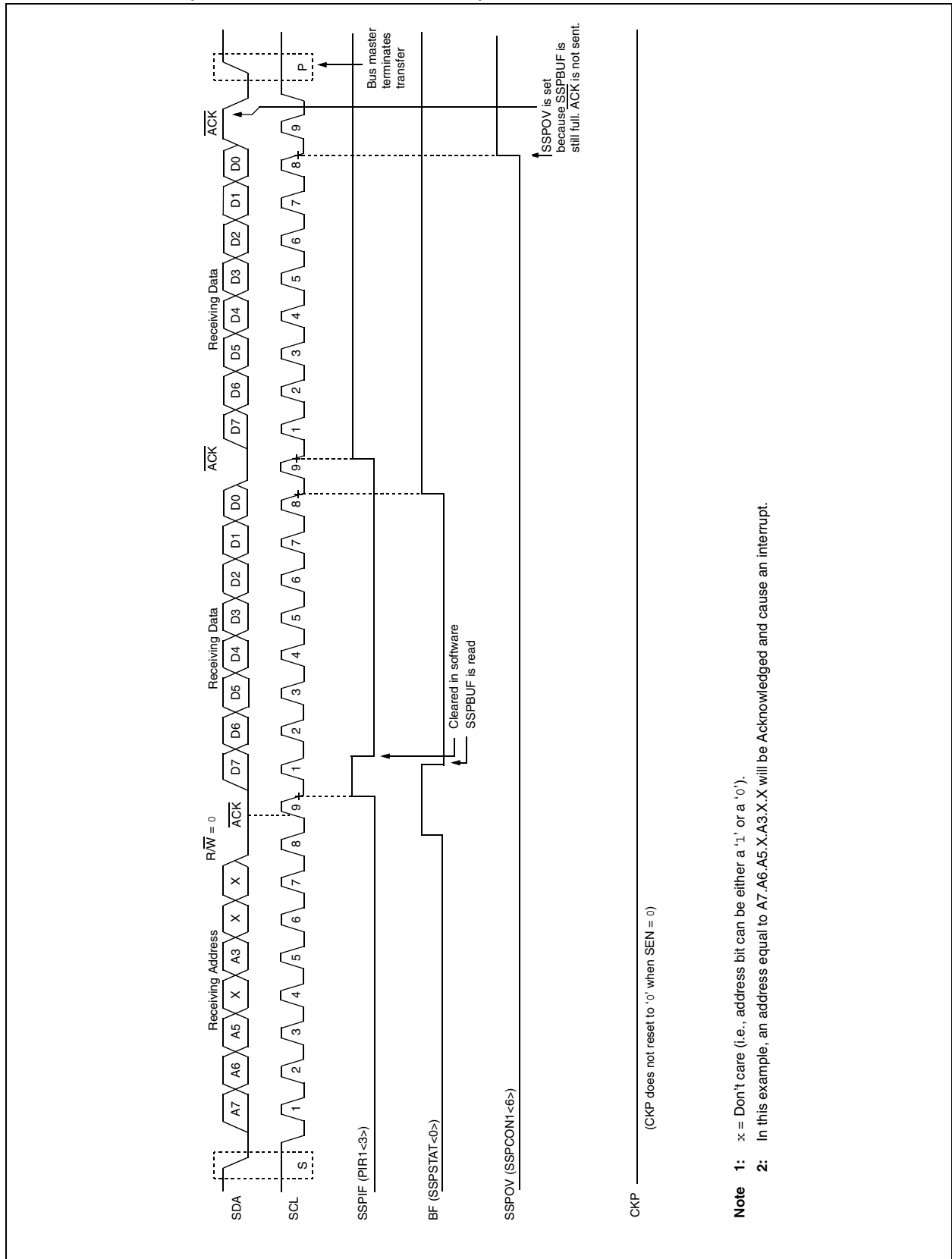

FIGURE 16-9: I²C™ SLAVE MODE TIMING WITH SEN = 0 AND ADMSK<5:1> = 01011 (RECEPTION, 7-BIT ADDRESS)



PIC18F85J90 FAMILY

FIGURE 16-10: I²C™ SLAVE MODE TIMING (TRANSMISSION, 7-BIT ADDRESS)

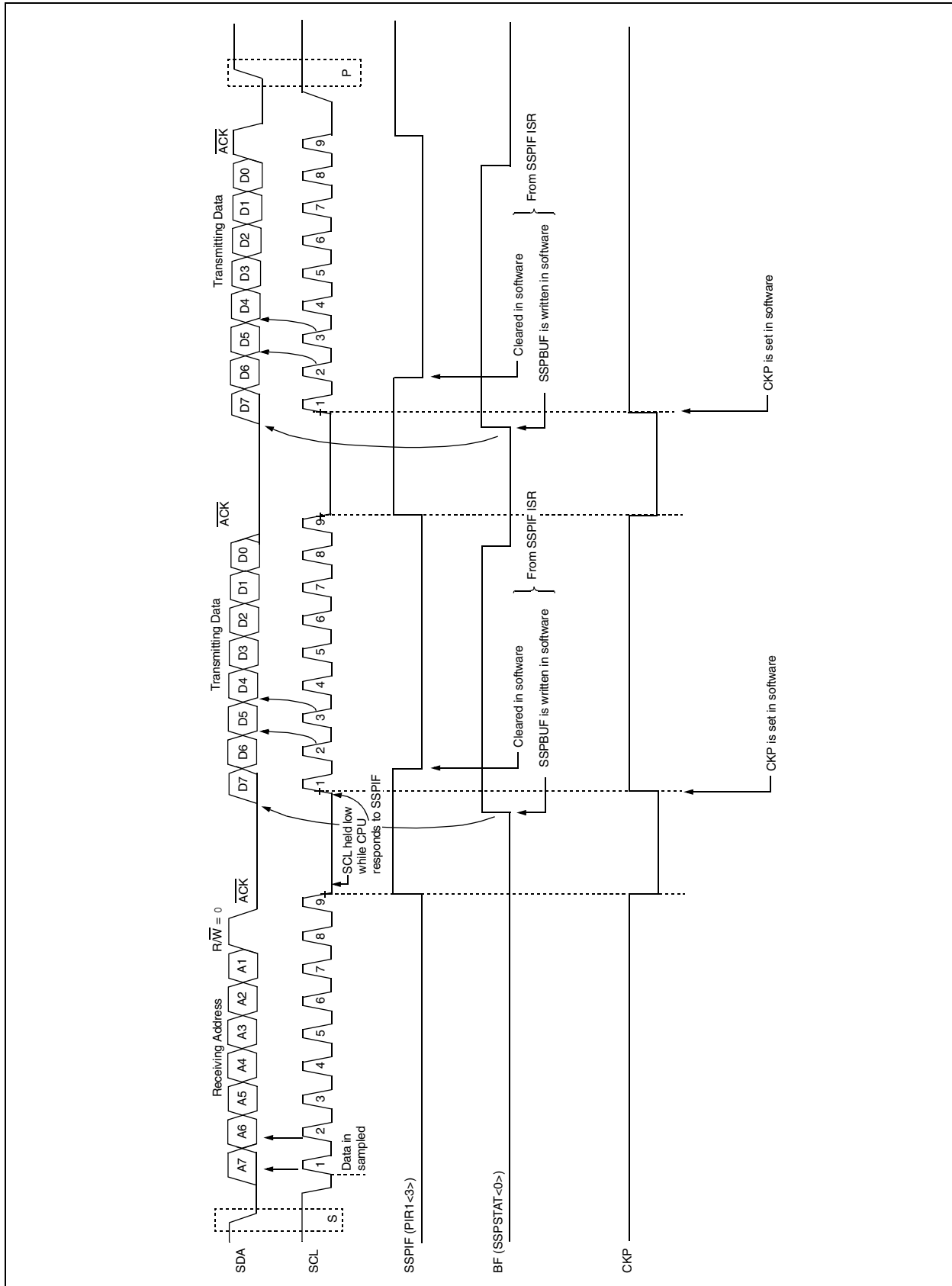
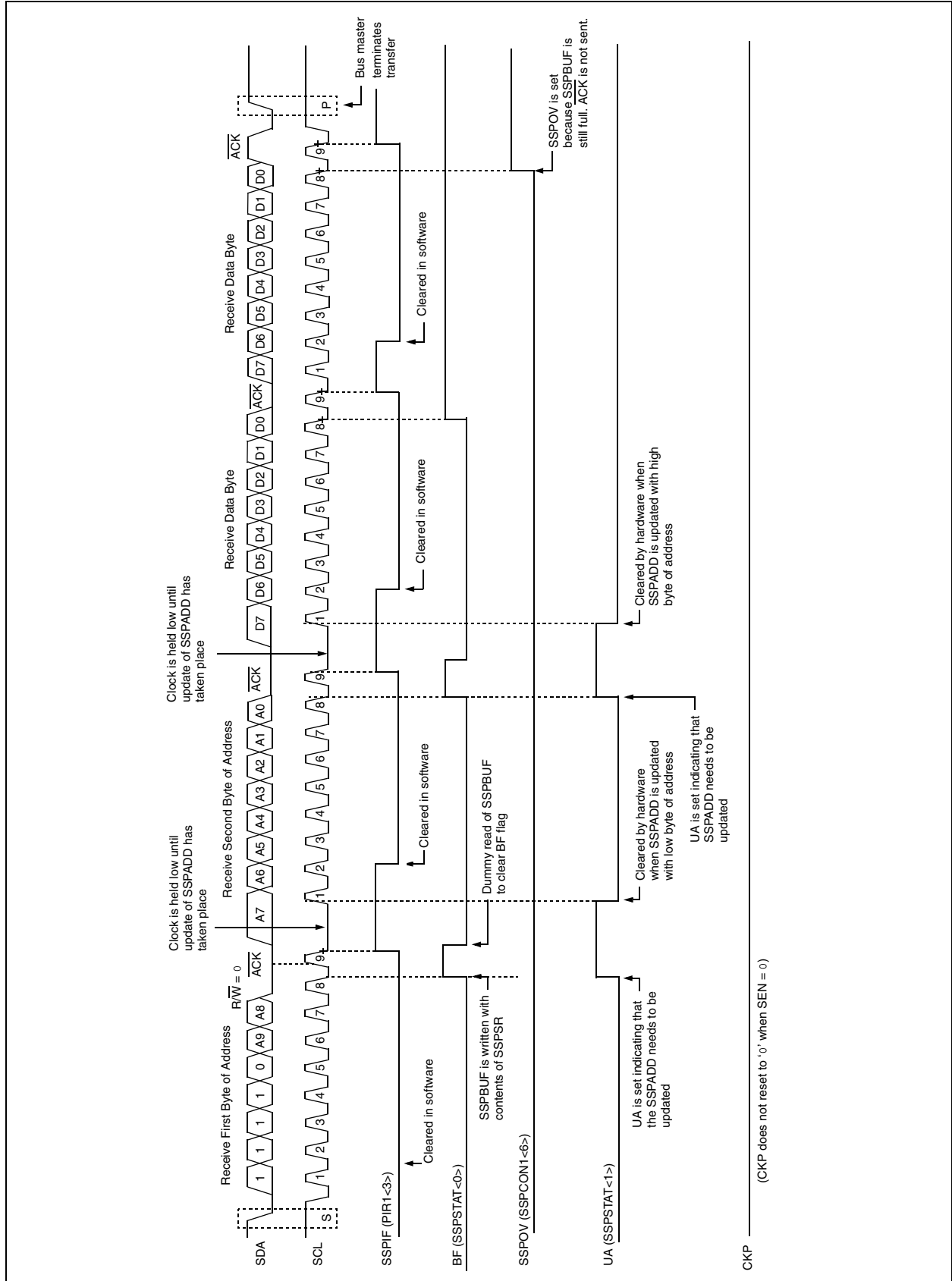
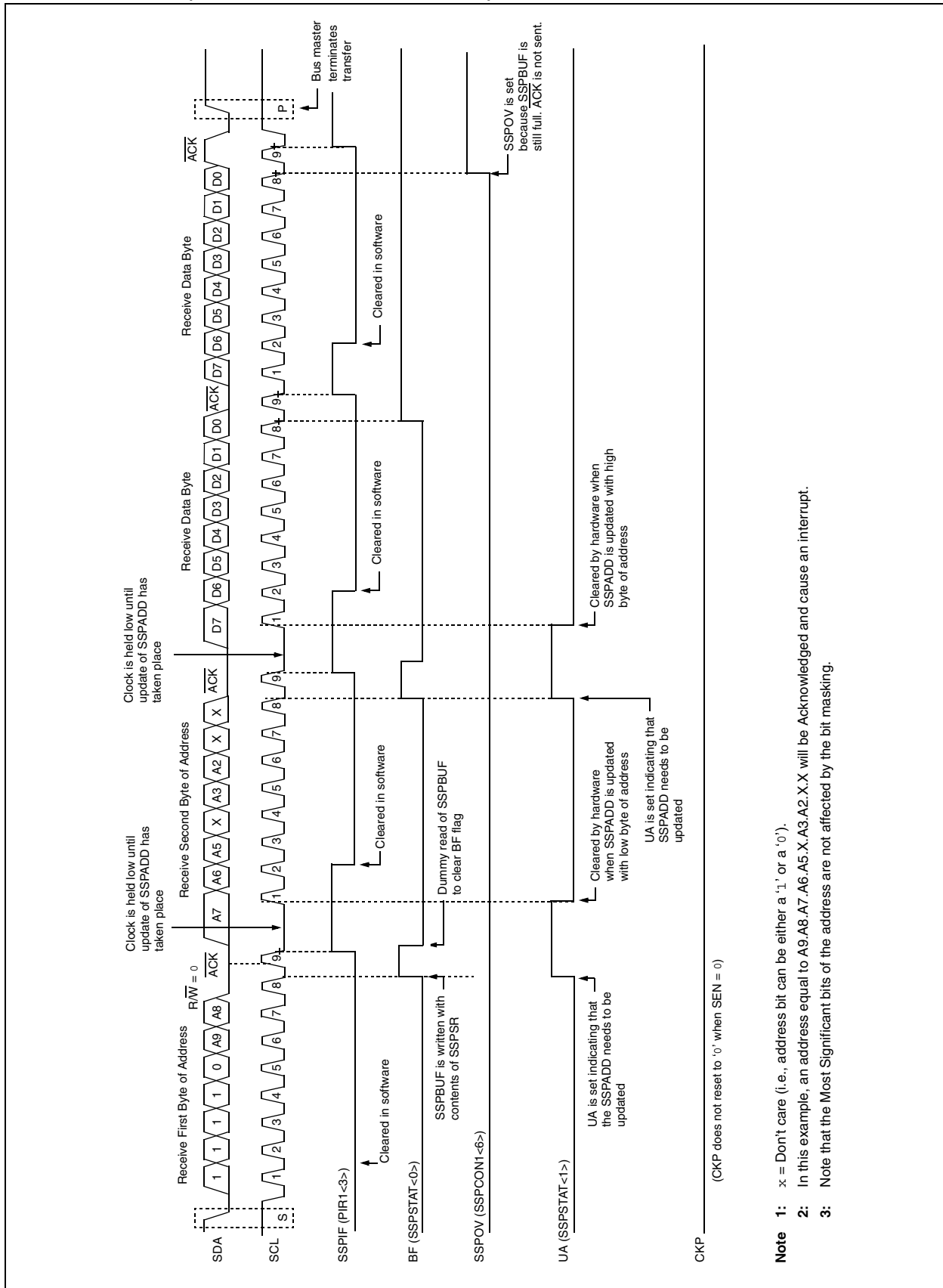

FIGURE 16-11: I²C™ SLAVE MODE TIMING WITH SEN = 0 (RECEPTION, 10-BIT ADDRESS)



PIC18F85J90 FAMILY

FIGURE 16-12: I²C™ SLAVE MODE TIMING WITH SEN = 0 AND ADMSK<5:1> = 01001 (RECEPTION, 10-BIT ADDRESS)



- Note 1:** x = Don't care (i.e., address bit can be either a '1' or a '0').
- Note 2:** In this example, an address equal to A9.A8.A7.A6.A5.X.A3.A2.X.X will be Acknowledged and cause an interrupt.
- Note 3:** Note that the Most Significant bits of the address are not affected by the bit masking.

FIGURE 16-13: I²C™ SLAVE MODE TIMING (TRANSMISSION, 10-BIT ADDRESS)

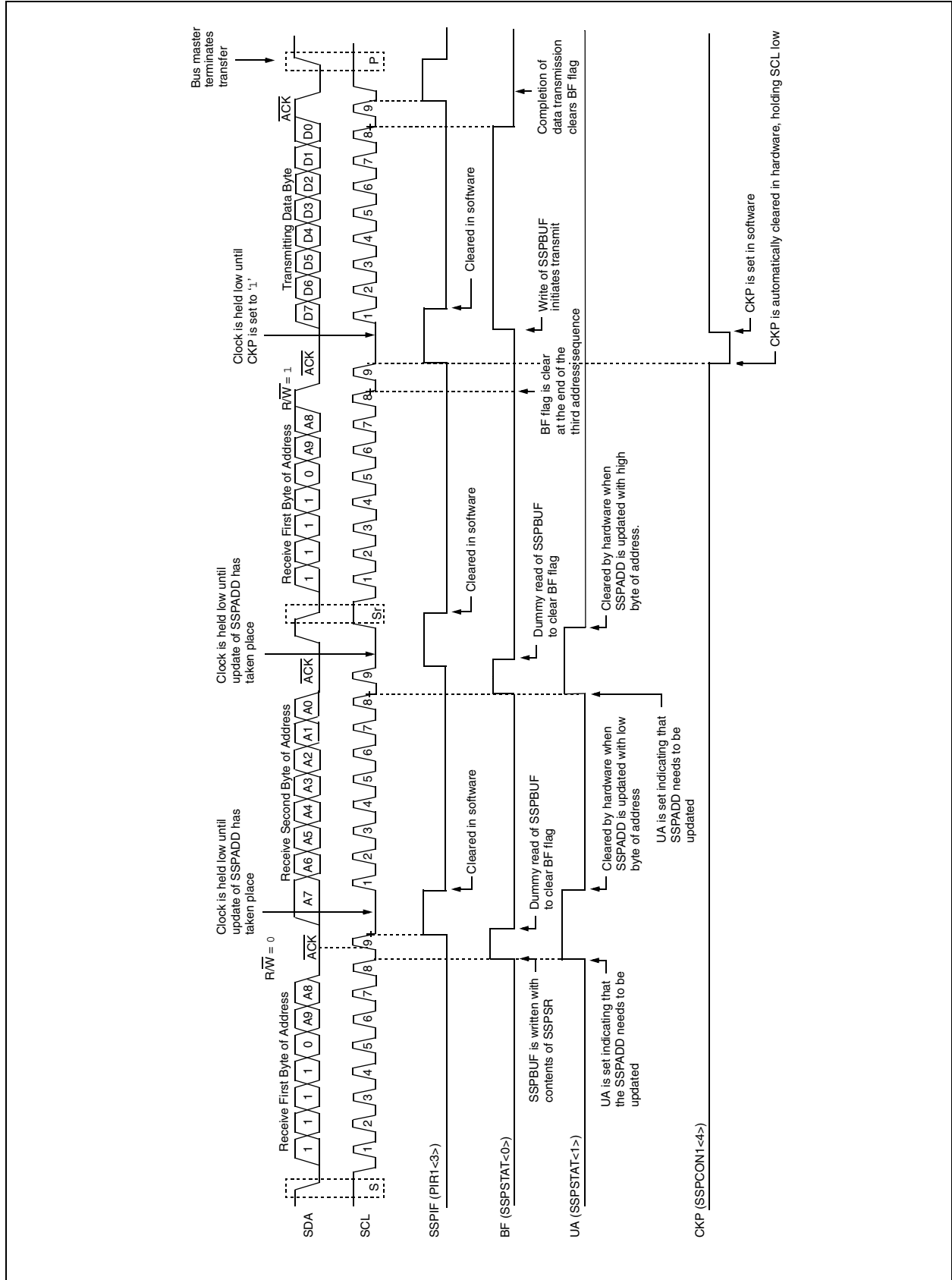

PIC18F85J90 FAMILY

16.4.4 CLOCK STRETCHING

Both 7-Bit and 10-Bit Slave modes implement automatic clock stretching during a transmit sequence.

The SEN bit (SSPCON2<0>) allows clock stretching to be enabled during receives. Setting SEN will cause the SCL pin to be held low at the end of each data receive sequence.

16.4.4.1 Clock Stretching for 7-Bit Slave Receive Mode (SEN = 1)

In 7-Bit Slave Receive mode, on the falling edge of the ninth clock at the end of the ACK sequence, if the BF bit is set, the CKP bit in the SSPCON1 register is automatically cleared, forcing the SCL output to be held low. The CKP being cleared to '0' will assert the SCL line low. The CKP bit must be set in the user's ISR before reception is allowed to continue. By holding the SCL line low, the user has time to service the ISR and read the contents of the SSPBUF before the master device can initiate another receive sequence. This will prevent buffer overruns from occurring (see Figure 16-15).

Note 1: If the user reads the contents of the SSPBUF before the falling edge of the ninth clock, thus clearing the BF bit, the CKP bit will not be cleared and clock stretching will not occur.

2: The CKP bit can be set in software regardless of the state of the BF bit. The user should be careful to clear the BF bit in the ISR before the next receive sequence in order to prevent an overflow condition.

16.4.4.2 Clock Stretching for 10-Bit Slave Receive Mode (SEN = 1)

In 10-Bit Slave Receive mode, during the address sequence, clock stretching automatically takes place but CKP is not cleared. During this time, if the UA bit is set after the ninth clock, clock stretching is initiated. The UA bit is set after receiving the upper byte of the 10-bit address and following the receive of the second byte of the 10-bit address with the R/W bit cleared to '0'. The release of the clock line occurs upon updating SSPADD. Clock stretching will occur on each data receive sequence as described in 7-bit mode.

Note: If the user polls the UA bit and clears it by updating the SSPADD register before the falling edge of the ninth clock occurs and if the user hasn't cleared the BF bit by reading the SSPBUF register before that time, then the CKP bit will still NOT be asserted low. Clock stretching on the basis of the state of the BF bit only occurs during a data sequence, not an address sequence.

16.4.4.3 Clock Stretching for 7-Bit Slave Transmit Mode

The 7-Bit Slave Transmit mode implements clock stretching by clearing the CKP bit after the falling edge of the ninth clock if the BF bit is clear. This occurs regardless of the state of the SEN bit.

The user's ISR must set the CKP bit before transmission is allowed to continue. By holding the SCL line low, the user has time to service the ISR and load the contents of the SSPBUF before the master device can initiate another transmit sequence (see Figure 16-10).

Note 1: If the user loads the contents of SSPBUF, setting the BF bit before the falling edge of the ninth clock, the CKP bit will not be cleared and clock stretching will not occur.

2: The CKP bit can be set in software regardless of the state of the BF bit.

16.4.4.4 Clock Stretching for 10-Bit Slave Transmit Mode

In 10-Bit Slave Transmit mode, clock stretching is controlled during the first two address sequences by the state of the UA bit, just as it is in 10-Bit Slave Receive mode. The first two addresses are followed by a third address sequence which contains the high-order bits of the 10-bit address and the R/W bit set to '1'. After the third address sequence is performed, the UA bit is not set, the module is now configured in Transmit mode and clock stretching is controlled by the BF flag as in 7-Bit Slave Transmit mode (see Figure 16-13).

16.4.4.5 Clock Synchronization and the CKP bit

When the CKP bit is cleared, the SCL output is forced to '0'. However, clearing the CKP bit will not assert the SCL output low until the SCL output is already sampled low. Therefore, the CKP bit will not assert the SCL line until an external I²C master device has

already asserted the SCL line. The SCL output will remain low until the CKP bit is set and all other devices on the I²C bus have deasserted SCL. This ensures that a write to the CKP bit will not violate the minimum high time requirement for SCL (see Figure 16-14).

FIGURE 16-14: CLOCK SYNCHRONIZATION TIMING

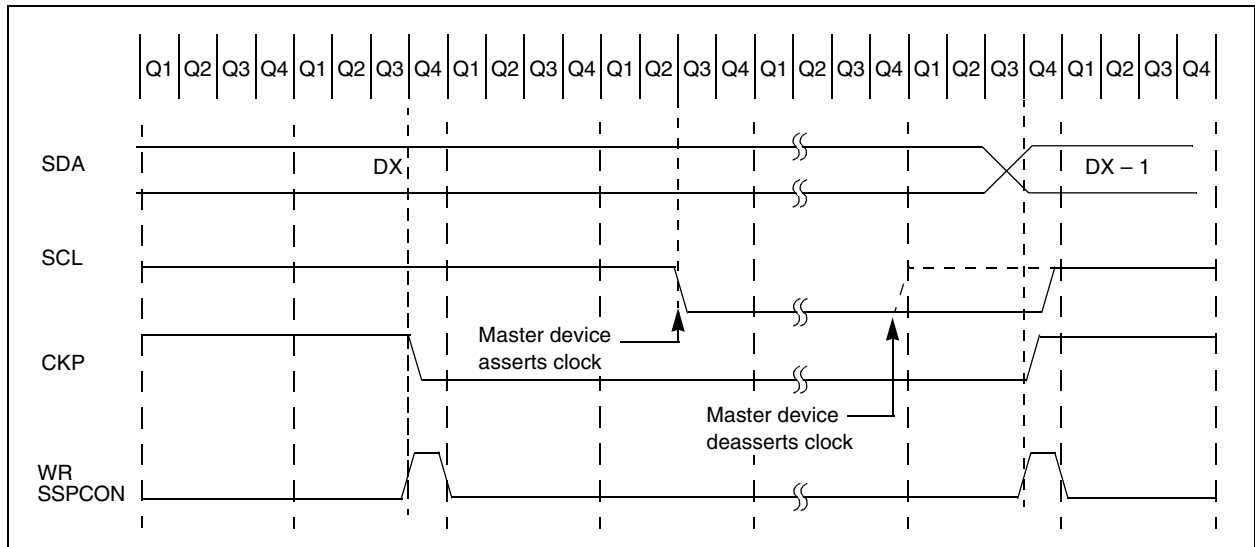

PIC18F85J90 FAMILY

FIGURE 16-15: I²C™ SLAVE MODE TIMING WITH SEN = 1 (RECEPTION, 7-BIT ADDRESS)

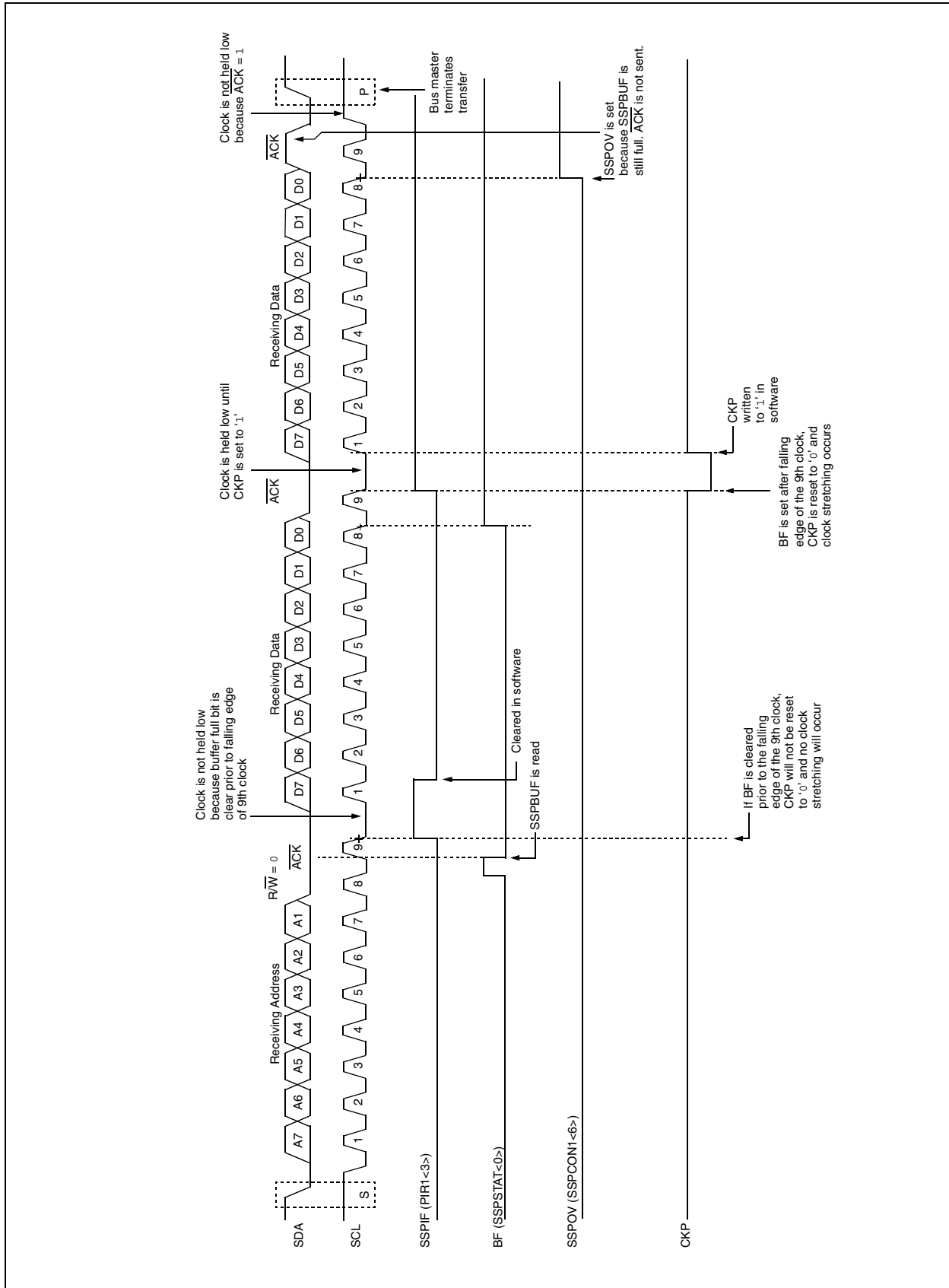
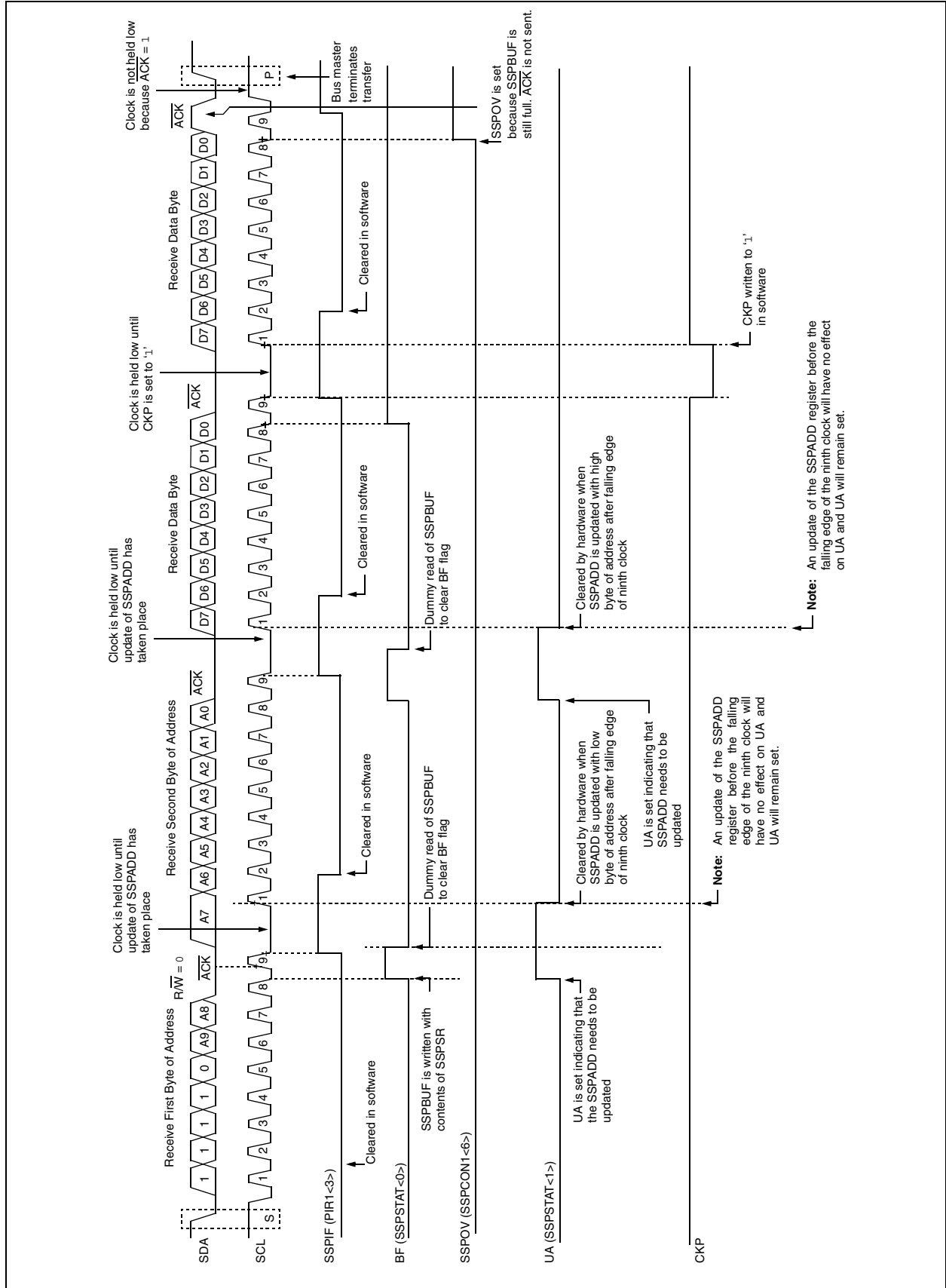

FIGURE 16-16: I²C™ SLAVE MODE TIMING WITH SEN = 1 (RECEPTION, 10-BIT ADDRESS)



PIC18F85J90 FAMILY

16.4.5 GENERAL CALL ADDRESS SUPPORT

The addressing procedure for the I²C bus is such that the first byte after the Start condition usually determines which device will be the slave addressed by the master. The exception is the general call address which can address all devices. When this address is used, all devices should, in theory, respond with an Acknowledge.

The general call address is one of eight addresses reserved for specific purposes by the I²C protocol. It consists of all '0's with $R/\overline{W} = 0$.

The general call address is recognized when the General Call Enable bit, GCEN, is enabled (SSPCON2<7> set). Following a Start bit detect, 8 bits are shifted into the SSPSR and the address is compared against the SSPADD. It is also compared to the general call address and fixed in hardware.

If the general call address matches, the SSPSR is transferred to the SSPBUF, the BF flag bit is set (eighth bit) and on the falling edge of the ninth bit (\overline{ACK} bit), the SSPIF interrupt flag bit is set.

When the interrupt is serviced, the source for the interrupt can be checked by reading the contents of the SSPBUF. The value can be used to determine if the address was device specific or a general call address.

In 10-bit mode, the SSPADD is required to be updated for the second half of the address to match and the UA bit is set (SSPSTAT<1>). If the general call address is sampled when the GCEN bit is set, while the slave is configured in 10-Bit Address mode, then the second half of the address is not necessary, the UA bit will not be set and the slave will begin receiving data after the Acknowledge (Figure 16-17).

FIGURE 16-17: SLAVE MODE GENERAL CALL ADDRESS SEQUENCE (7 OR 10-BIT ADDRESS MODE)

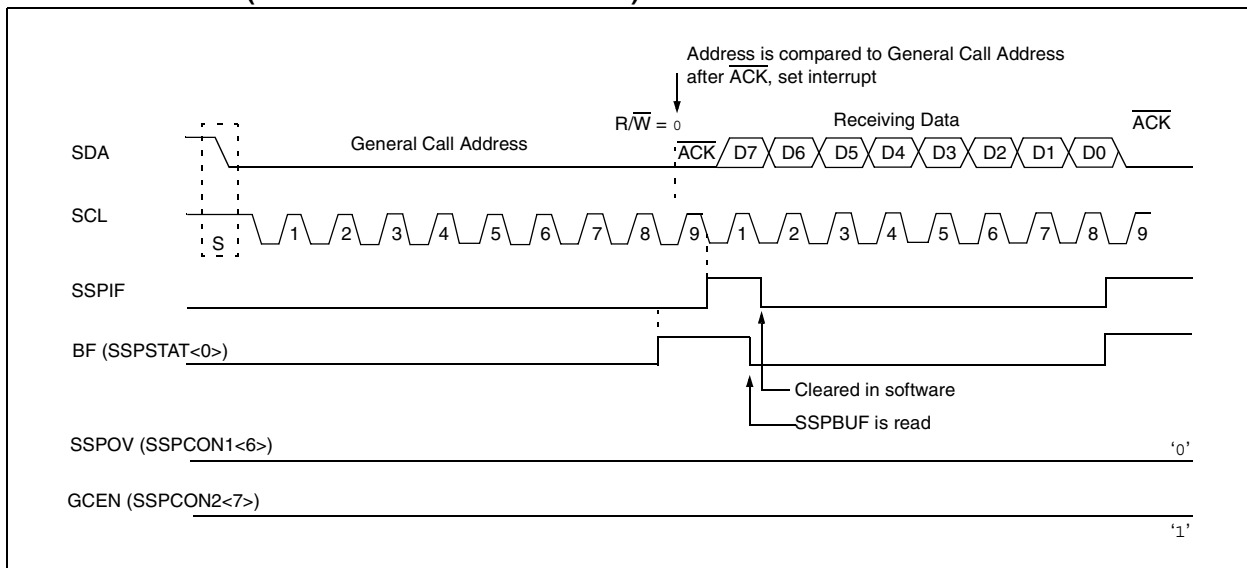

PIC18F85J90 FAMILY

16.4.6 MASTER MODE

Master mode is enabled by setting and clearing the appropriate SSPM bits in SSPCON1 and by setting the SSPEN bit. In Master mode, the SCL and SDA lines are manipulated by the MSSP hardware.

Master mode of operation is supported by interrupt generation on the detection of the Start and Stop conditions. The Stop (P) and Start (S) bits are cleared from a Reset or when the MSSP module is disabled. Control of the I²C bus may be taken when the P bit is set, or the bus is Idle, with both the S and P bits clear.

In Firmware Controlled Master mode, user code conducts all I²C bus operations based on Start and Stop bit conditions.

Once Master mode is enabled, the user has six options.

1. Assert a Start condition on SDA and SCL.
2. Assert a Repeated Start condition on SDA and SCL.
3. Write to the SSPBUF register initiating transmission of data/address.
4. Configure the I²C port to receive data.
5. Generate an Acknowledge condition at the end of a received byte of data.
6. Generate a Stop condition on SDA and SCL.

Note: The MSSP module, when configured in I²C Master mode, does not allow queueing of events. For instance, the user is not allowed to initiate a Start condition and immediately write the SSPBUF register to initiate transmission before the Start condition is complete. In this case, the SSPBUF will not be written to and the WCOL bit will be set, indicating that a write to the SSPBUF did not occur.

The following events will cause the MSSP Interrupt Flag bit, SSPIF, to be set (and MSSP interrupt, if enabled):

- Start condition
- Stop condition
- Data transfer byte transmitted/received
- Acknowledge transmit
- Repeated Start

FIGURE 16-18: MSSP BLOCK DIAGRAM (I²C™ MASTER MODE)

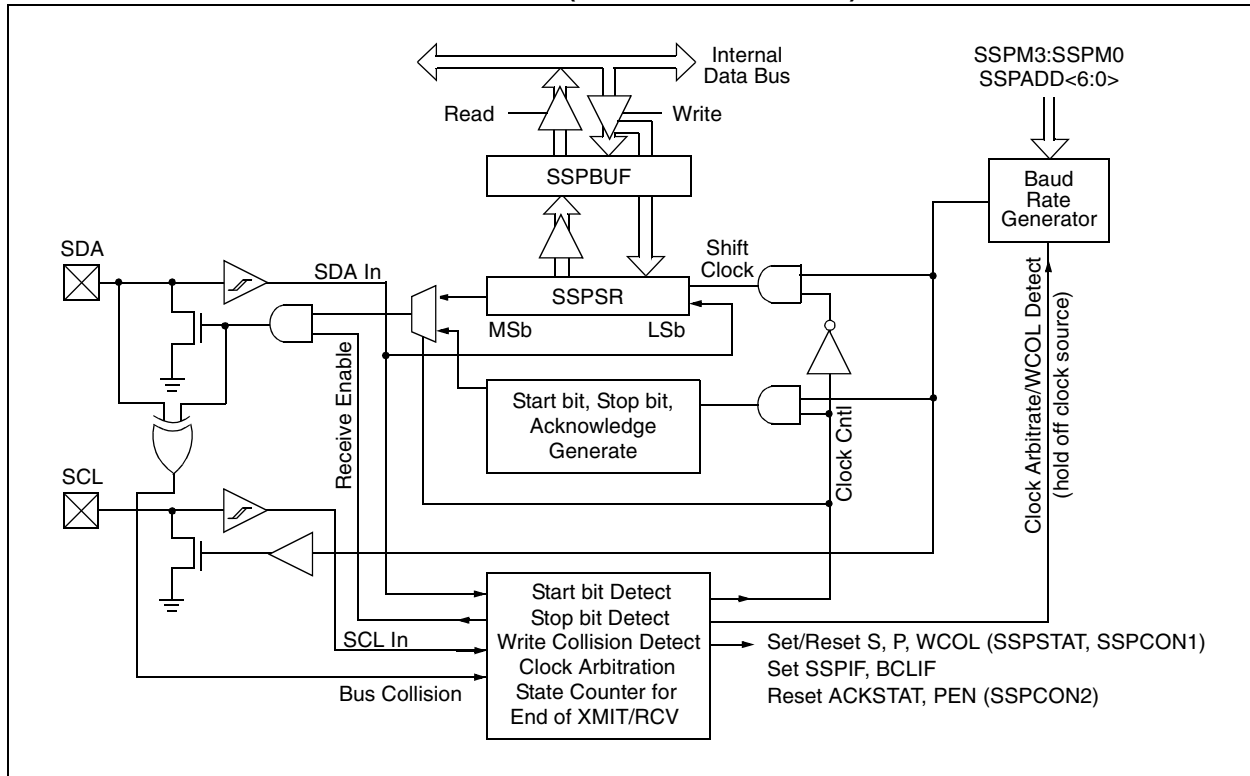

PIC18F85J90 FAMILY

16.4.6.1 I²C Master Mode Operation

The master device generates all of the serial clock pulses and the Start and Stop conditions. A transfer is ended with a Stop condition or with a Repeated Start condition. Since the Repeated Start condition is also the beginning of the next serial transfer, the I²C bus will not be released.

In Master Transmitter mode, serial data is output through SDA, while SCL outputs the serial clock. The first byte transmitted contains the slave address of the receiving device (7 bits) and the Read/Write (R/W) bit. In this case, the R/W bit will be logic '0'. Serial data is transmitted 8 bits at a time. After each byte is transmitted, an Acknowledge bit is received. Start and Stop conditions are output to indicate the beginning and the end of a serial transfer.

In Master Receive mode, the first byte transmitted contains the slave address of the transmitting device (7 bits) and the R/W bit. In this case, the R/W bit will be logic '1'. Thus, the first byte transmitted is a 7-bit slave address followed by a '1' to indicate the receive bit. Serial data is received via SDA, while SCL outputs the serial clock. Serial data is received 8 bits at a time. After each byte is received, an Acknowledge bit is transmitted. Start and Stop conditions indicate the beginning and end of transmission.

The Baud Rate Generator used for the SPI mode operation is used to set the SCL clock frequency for either 100 kHz, 400 kHz or 1 MHz I²C operation. See **Section 16.4.7 "Baud Rate"** for more detail.

A typical transmit sequence would go as follows:

1. The user generates a Start condition by setting the Start Enable bit, SEN (SSPCON2<0>).
2. SSPIF is set. The MSSP module will wait the required start time before any other operation takes place.
3. The user loads the SSPBUF with the slave address to transmit.
4. Address is shifted out the SDA pin until all 8 bits are transmitted.
5. The MSSP module shifts in the ACK bit from the slave device and writes its value into the SSPCON2 register (SSPCON2<6>).
6. The MSSP module generates an interrupt at the end of the ninth clock cycle by setting the SSPIF bit.
7. The user loads the SSPBUF with eight bits of data.
8. Data is shifted out the SDA pin until all 8 bits are transmitted.
9. The MSSP module shifts in the ACK bit from the slave device and writes its value into the SSPCON2 register (SSPCON2<6>).
10. The MSSP module generates an interrupt at the end of the ninth clock cycle by setting the SSPIF bit.
11. The user generates a Stop condition by setting the Stop Enable bit, PEN (SSPCON2<2>).
12. Interrupt is generated once the Stop condition is complete.

PIC18F85J90 FAMILY

16.4.7 BAUD RATE

In I²C Master mode, the Baud Rate Generator (BRG) reload value is placed in the lower 7 bits of the SSPADD register (Figure 16-19). When a write occurs to SSPBUF, the Baud Rate Generator will automatically begin counting. The BRG counts down to '0' and stops until another reload has taken place. The BRG count is decremented twice per instruction cycle (TCY) on the Q2 and Q4 clocks. In I²C Master mode, the BRG is reloaded automatically.

Once the given operation is complete (i.e., transmission of the last data bit is followed by ACK), the internal clock will automatically stop counting and the SCL pin will remain in its last state.

Table 16-3 demonstrates clock rates based on instruction cycles and the BRG value loaded into SSPADD.

16.4.7.1 Baud Rate Generation in Power-Managed Modes

When the device is operating in one of the power-managed modes, the clock source to the BRG may change frequency or even stop, depending on the mode and clock source selected. Switching to a Run or Idle mode from either the secondary clock or internal oscillator is likely to change the clock rate to the BRG. In Sleep mode, the BRG will not be clocked at all.

FIGURE 16-19: BAUD RATE GENERATOR BLOCK DIAGRAM

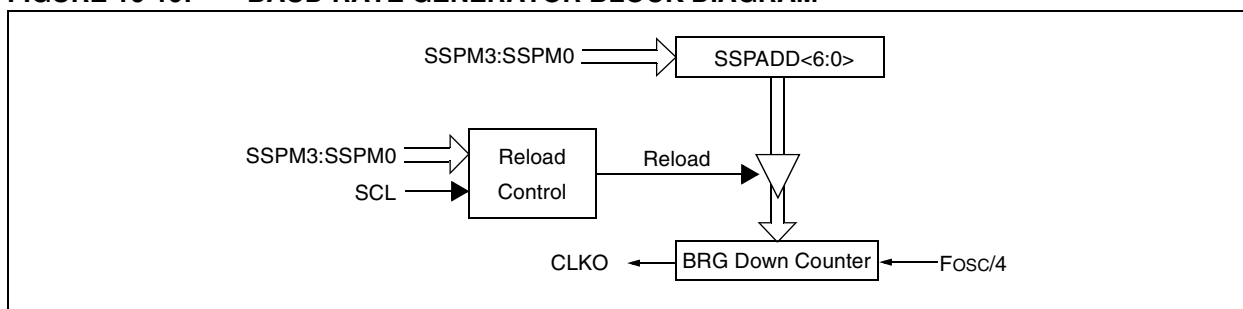

TABLE 16-3: I²C™ CLOCK RATE w/BRG

Fcy	Fcy * 2	BRG Value	Fscl (2 Rollovers of BRG)
10 MHz	20 MHz	18h	400 kHz ⁽¹⁾
10 MHz	20 MHz	1Fh	312.5 kHz
10 MHz	20 MHz	63h	100 kHz
4 MHz	8 MHz	09h	400 kHz ⁽¹⁾
4 MHz	8 MHz	0Ch	308 kHz
4 MHz	8 MHz	27h	100 kHz
1 MHz	2 MHz	02h	333 kHz ⁽¹⁾
1 MHz	2 MHz	09h	100 kHz
1 MHz	2 MHz	00h	1 MHz ⁽¹⁾

Note 1: The I²C™ interface does not conform to the 400 kHz I²C specification (which applies to rates greater than 100 kHz) in all details, but may be used with care where higher rates are required by the application.

PIC18F85J90 FAMILY

16.4.7.2 Clock Arbitration

Clock arbitration occurs when the master, during any receive, transmit or Repeated Start/Stop condition, deasserts the SCL pin (SCL allowed to float high). When the SCL pin is allowed to float high, the Baud Rate Generator (BRG) is suspended from counting until the SCL pin is actually sampled high. When the

SCL pin is sampled high, the Baud Rate Generator is reloaded with the contents of SSPADD<6:0> and begins counting. This ensures that the SCL high time will always be at least one BRG rollover count in the event that the clock is held low by an external device (Figure 16-20).

FIGURE 16-20: BAUD RATE GENERATOR TIMING WITH CLOCK ARBITRATION

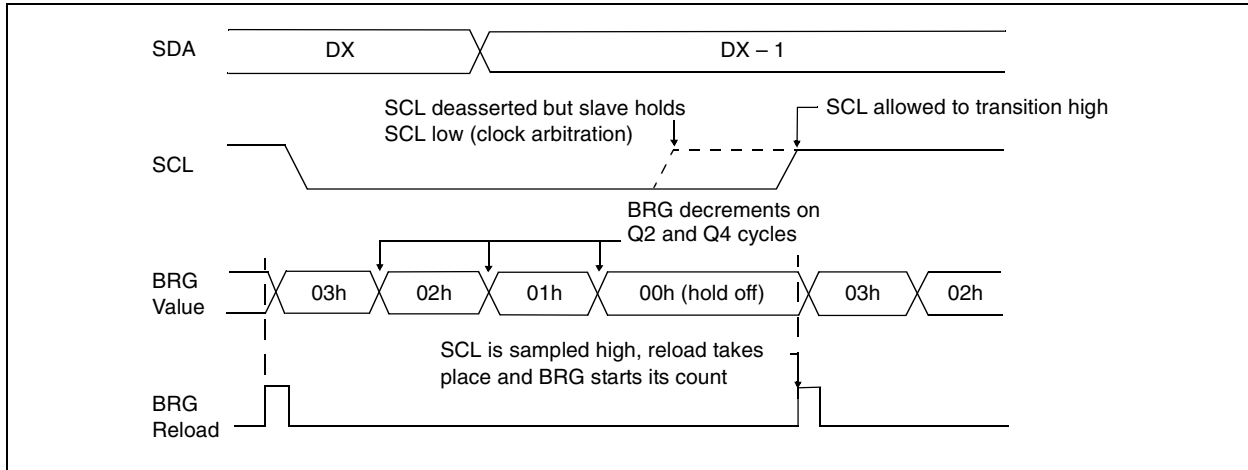

16.4.8 I²C MASTER MODE START CONDITION TIMING

To initiate a Start condition, the user sets the Start Enable bit, SEN (SSPCON2<0>). If the SDA and SCL pins are sampled high, the Baud Rate Generator is reloaded with the contents of SSPADD<6:0> and starts its count. If SCL and SDA are both sampled high when the Baud Rate Generator times out (TBRG), the SDA pin is driven low. The action of the SDA being driven low while SCL is high is the Start condition and causes the S bit (SSPSTAT<3>) to be set. Following this, the Baud Rate Generator is reloaded with the contents of SSPADD<6:0> and resumes its count. When the Baud Rate Generator times out (TBRG), the SEN bit (SSPCON2<0>) will be automatically cleared by hardware. The Baud Rate Generator is suspended, leaving the SDA line held low and the Start condition is complete.

Note: If at the beginning of the Start condition, the SDA and SCL pins are already sampled low, or if during the Start condition, the SCL line is sampled low before the SDA line is driven low, a bus collision occurs. The Bus Collision Interrupt Flag, BCLIF, is set, the Start condition is aborted and the I²C module is reset into its Idle state.

16.4.8.1 WCOL Status Flag

If the user writes the SSPBUF when a Start sequence is in progress, the WCOL is set and the contents of the buffer are unchanged (the write doesn't occur).

Note: Because queueing of events is not allowed, writing to the lower 5 bits of SSPCON2 is disabled until the Start condition is complete.

FIGURE 16-21: FIRST START BIT TIMING

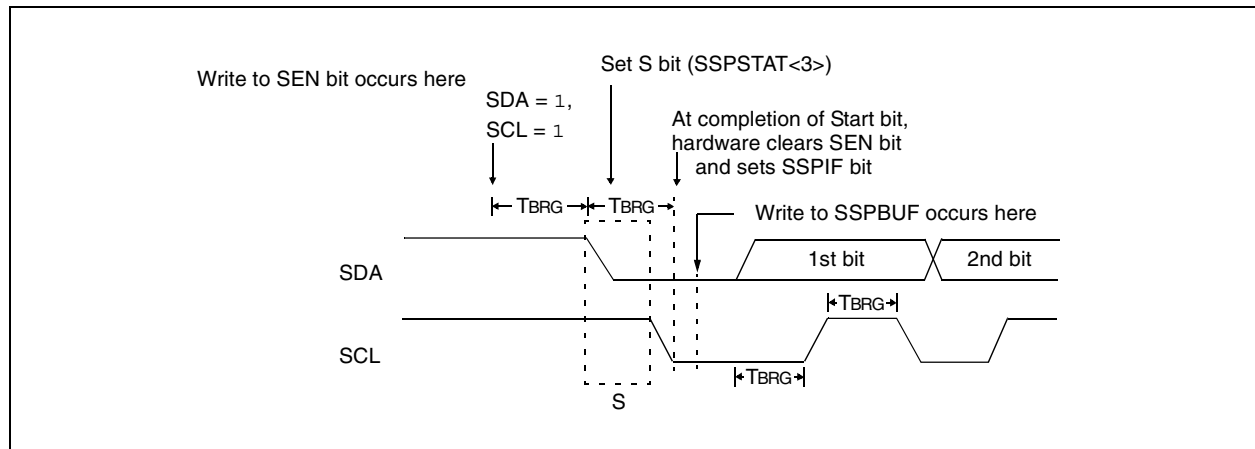

PIC18F85J90 FAMILY

16.4.9 I²C MASTER MODE REPEATED START CONDITION TIMING

A Repeated Start condition occurs when the RSEN bit (SSPCON2<1>) is programmed high and the I²C logic module is in the Idle state. When the RSEN bit is set, the SCL pin is asserted low. When the SCL pin is sampled low, the Baud Rate Generator is loaded with the contents of SSPADD<6:0> and begins counting. The SDA pin is released (brought high) for one Baud Rate Generator count (TBRG). When the Baud Rate Generator times out, if SDA is sampled high, the SCL pin will be deasserted (brought high). When SCL is sampled high, the Baud Rate Generator is reloaded with the contents of SSPADD<6:0> and begins counting. SDA and SCL must be sampled high for one TBRG. This action is then followed by assertion of the SDA pin (SDA = 0) for one TBRG while SCL is high. Following this, the RSEN bit (SSPCON2<1>) will be automatically cleared and the Baud Rate Generator will not be reloaded, leaving the SDA pin held low. As soon as a Start condition is detected on the SDA and SCL pins, the S bit (SSPSTAT<3>) will be set. The SSPIF bit will not be set until the Baud Rate Generator has timed out.

Note 1: If RSEN is programmed while any other event is in progress, it will not take effect.

2: A bus collision during the Repeated Start condition occurs if:

- SDA is sampled low when SCL goes from low-to-high.
- SCL goes low before SDA is asserted low. This may indicate that another master is attempting to transmit a data '1'.

Immediately following the SSPIF bit getting set, the user may write the SSPBUF with the 7-bit address in 7-bit mode or the default first address in 10-bit mode. After the first eight bits are transmitted and an ACK is received, the user may then transmit an additional eight bits of address (10-bit mode) or eight bits of data (7-bit mode).

16.4.9.1 WCOL Status Flag

If the user writes the SSPBUF when a Repeated Start sequence is in progress, the WCOL is set and the contents of the buffer are unchanged (the write doesn't occur).

Note: Because queueing of events is not allowed, writing of the lower 5 bits of SSPCON2 is disabled until the Repeated Start condition is complete.

FIGURE 16-22: REPEATED START CONDITION WAVEFORM

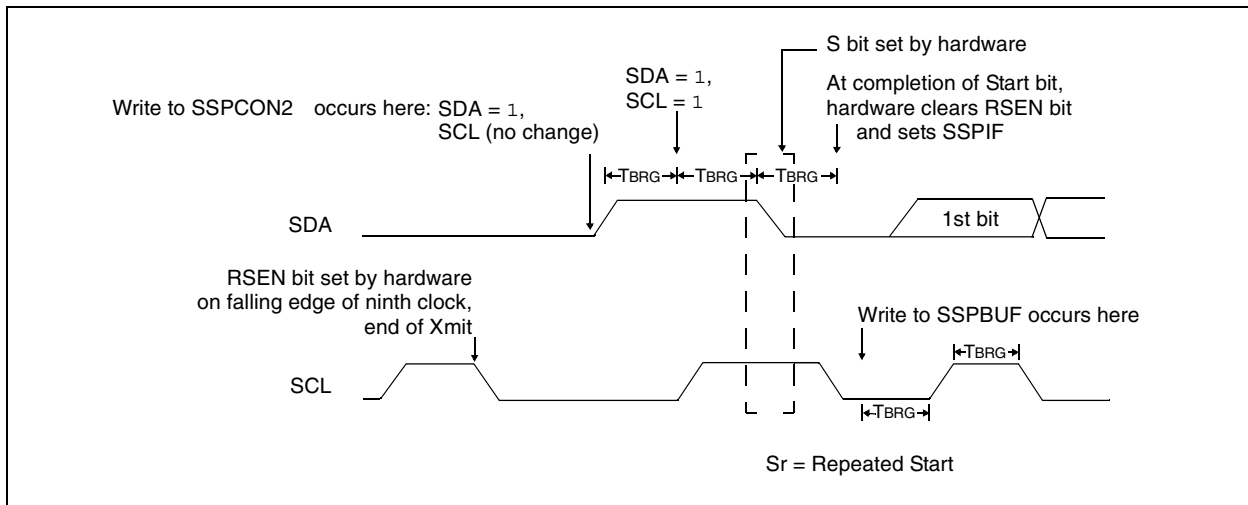

16.4.10 I²C MASTER MODE TRANSMISSION

Transmission of a data byte, a 7-bit address or the other half of a 10-bit address is accomplished by simply writing a value to the SSPBUF register. This action will set the Buffer Full bit, BF, and allow the Baud Rate Generator to begin counting and start the next transmission. Each bit of address/data will be shifted out onto the SDA pin after the falling edge of SCL is asserted (see data hold time specification parameter 106). SCL is held low for one Baud Rate Generator rollover count (TBRG). Data should be valid before SCL is released high (see data setup time specification parameter 107). When the SCL pin is released high, it is held that way for TBRG. The data on the SDA pin must remain stable for that duration and some hold time after the next falling edge of SCL. After the eighth bit is shifted out (the falling edge of the eighth clock), the BF flag is cleared and the master releases SDA. This allows the slave device being addressed to respond with an ACK bit during the ninth bit time if an address match occurred, or if data was received properly. The status of ACK is written into the ACKDT bit on the falling edge of the ninth clock. If the master receives an Acknowledge, the Acknowledge Status bit, ACKSTAT, is cleared; if not, the bit is set. After the ninth clock, the SSPIF bit is set and the master clock (Baud Rate Generator) is suspended until the next data byte is loaded into the SSPBUF, leaving SCL low and SDA unchanged (Figure 16-23).

After the write to the SSPBUF, each bit of the address will be shifted out on the falling edge of SCL until all seven address bits and the R/W bit are completed. On the falling edge of the eighth clock, the master will deassert the SDA pin, allowing the slave to respond with an Acknowledge. On the falling edge of the ninth clock, the master will sample the SDA pin to see if the address was recognized by a slave. The status of the ACK bit is loaded into the ACKSTAT status bit (SSPCON2<6>). Following the falling edge of the ninth clock transmission of the address, the SSPIF is set, the BF flag is cleared and the Baud Rate Generator is turned off until another write to the SSPBUF takes place, holding SCL low and allowing SDA to float.

16.4.10.1 BF Status Flag

In Transmit mode, the BF bit (SSPSTAT<0>) is set when the CPU writes to SSPBUF and is cleared when all 8 bits are shifted out.

16.4.10.2 WCOL Status Flag

If the user writes to the SSPBUF when a transmit is already in progress (i.e., SSPSR is still shifting out a data byte), the WCOL is set and the contents of the buffer are unchanged (the write doesn't occur) after 2 Tcy after the SSPBUF write. If SSPBUF is rewritten within 2 Tcy, the WCOL bit is set and SSPBUF is updated. This may result in a corrupted transfer.

The user should verify that the WCOL is clear after each write to SSPBUF to ensure the transfer is correct. In all cases, WCOL must be cleared in software.

16.4.10.3 ACKSTAT Status Flag

In Transmit mode, the ACKSTAT bit (SSPCON2<6>) is cleared when the slave has sent an Acknowledge (ACK = 0) and is set when the slave does not Acknowledge (ACK = 1). A slave sends an Acknowledge when it has recognized its address (including a general call), or when the slave has properly received its data.

16.4.11 I²C MASTER MODE RECEPTION

Master mode reception is enabled by programming the Receive Enable bit, RCEN (SSPCON2<3>).

Note: The MSSP module must be in an Idle state before the RCEN bit is set or the RCEN bit will be disregarded.

The Baud Rate Generator begins counting and on each rollover, the state of the SCL pin changes (high-to-low/low-to-high) and data is shifted into the SSPSR. After the falling edge of the eighth clock, the receive enable flag is automatically cleared, the contents of the SSPSR are loaded into the SSPBUF, the BF flag bit is set, the SSPIF flag bit is set and the Baud Rate Generator is suspended from counting, holding SCL low. The MSSP is now in Idle state awaiting the next command. When the buffer is read by the CPU, the BF flag bit is automatically cleared. The user can then send an Acknowledge bit at the end of reception by setting the Acknowledge Sequence Enable bit, ACKEN (SSPCON2<4>).

16.4.11.1 BF Status Flag

In receive operation, the BF bit is set when an address or data byte is loaded into SSPBUF from SSPSR. It is cleared when the SSPBUF register is read.

16.4.11.2 SSPOV Status Flag

In receive operation, the SSPOV bit is set when 8 bits are received into the SSPSR and the BF flag bit is already set from a previous reception.

16.4.11.3 WCOL Status Flag

If the user writes the SSPBUF when a receive is already in progress (i.e., SSPSR is still shifting in a data byte), the WCOL bit is set and the contents of the buffer are unchanged (the write doesn't occur).

PIC18F85J90 FAMILY

FIGURE 16-23: I²C™ MASTER MODE WAVEFORM (TRANSMISSION, 7 OR 10-BIT ADDRESS)

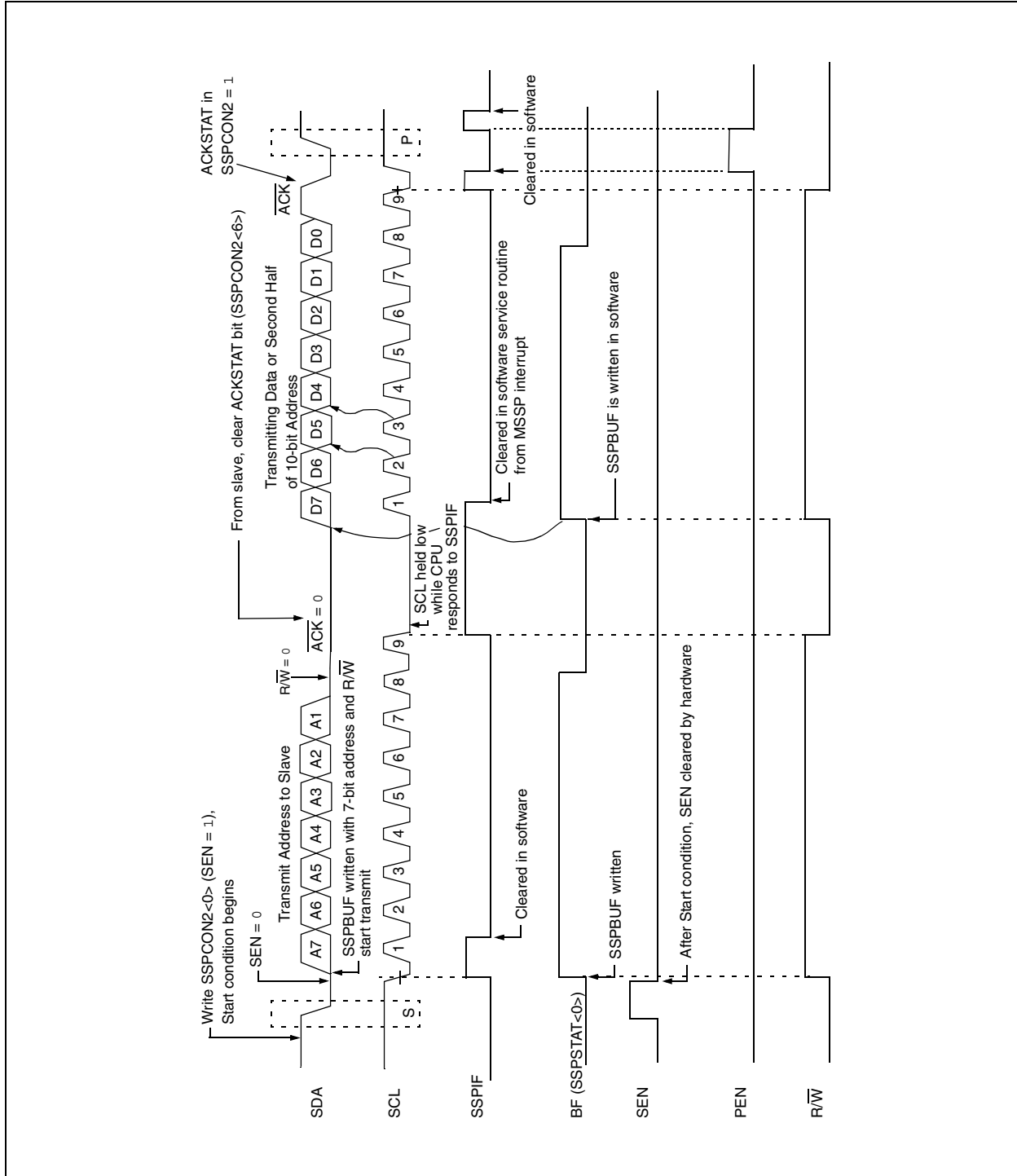
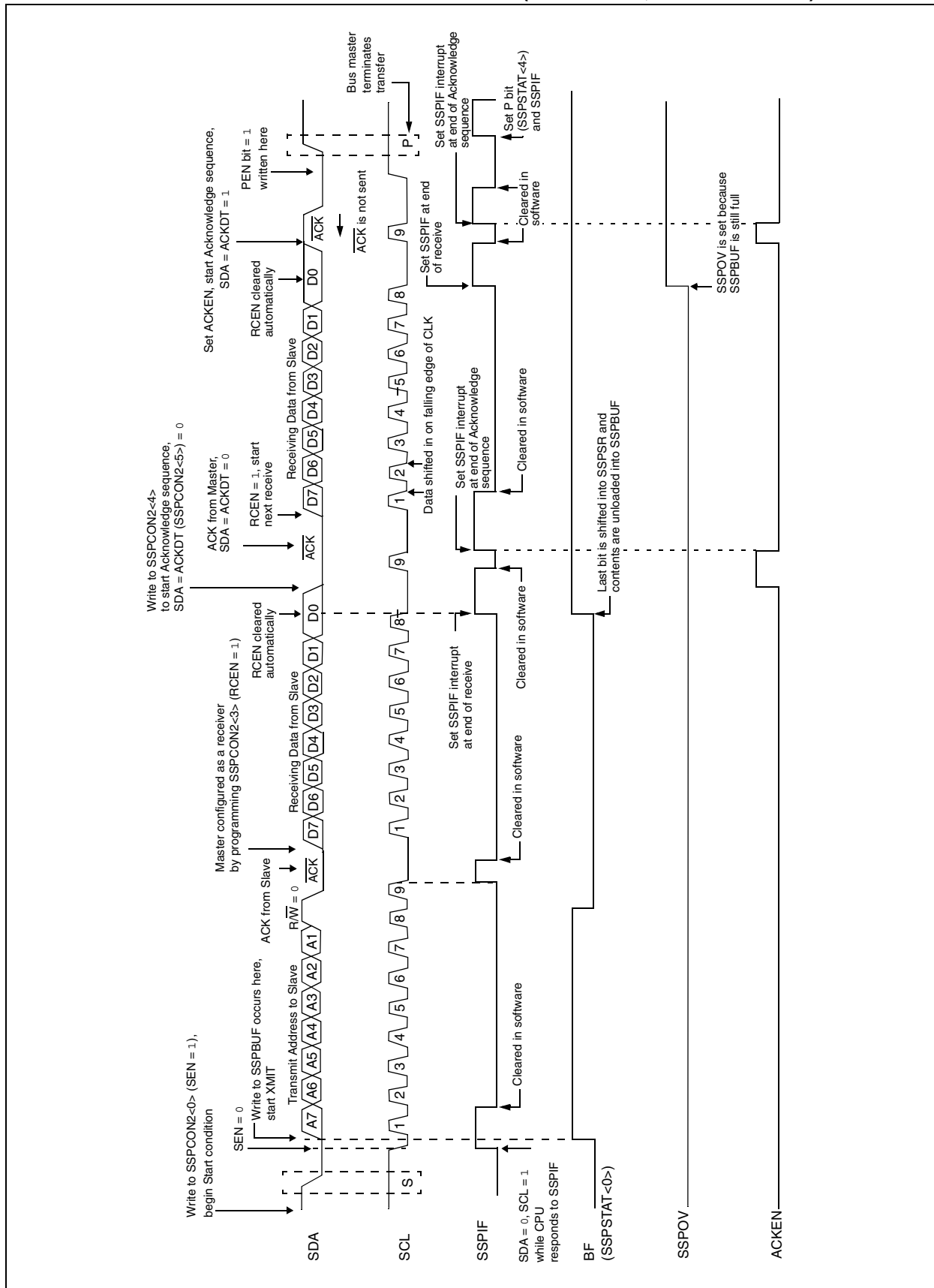

FIGURE 16-24: I²C™ MASTER MODE WAVEFORM (RECEPTION, 7-BIT ADDRESS)



PIC18F85J90 FAMILY

16.4.12 ACKNOWLEDGE SEQUENCE TIMING

An Acknowledge sequence is enabled by setting the Acknowledge Sequence Enable bit, ACKEN (SSPCON2<4>). When this bit is set, the SCL pin is pulled low and the contents of the Acknowledge data bit are presented on the SDA pin. If the user wishes to generate an Acknowledge, then the ACKDT bit should be cleared. If not, the user should set the ACKDT bit before starting an Acknowledge sequence. The Baud Rate Generator then counts for one rollover period (TBRG) and the SCL pin is deasserted (pulled high). When the SCL pin is sampled high (clock arbitration), the Baud Rate Generator counts for TBRG. The SCL pin is then pulled low. Following this, the ACKEN bit is automatically cleared, the Baud Rate Generator is turned off and the MSSP module then goes into Idle mode (Figure 16-25).

16.4.12.1 WCOL Status Flag

If the user writes the SSPBUF when an Acknowledge sequence is in progress, then WCOL is set and the contents of the buffer are unchanged (the write doesn't occur).

16.4.13 STOP CONDITION TIMING

A Stop bit is asserted on the SDA pin at the end of a receive/transmit by setting the Stop Sequence Enable bit, PEN (SSPCON2<2>). At the end of a receive/transmit, the SCL line is held low after the falling edge of the ninth clock. When the PEN bit is set, the master will assert the SDA line low. When the SDA line is sampled low, the Baud Rate Generator is reloaded and counts down to '0'. When the Baud Rate Generator times out, the SCL pin will be brought high and one TBRG (Baud Rate Generator rollover count) later, the SDA pin will be deasserted. When the SDA pin is sampled high while SCL is high, the P bit (SSPSTAT<4>) is set. A TBRG later, the PEN bit is cleared and the SSPIF bit is set (Figure 16-26).

16.4.13.1 WCOL Status Flag

If the user writes the SSPBUF when a Stop sequence is in progress, then the WCOL bit is set and the contents of the buffer are unchanged (the write doesn't occur).

FIGURE 16-25: ACKNOWLEDGE SEQUENCE WAVEFORM

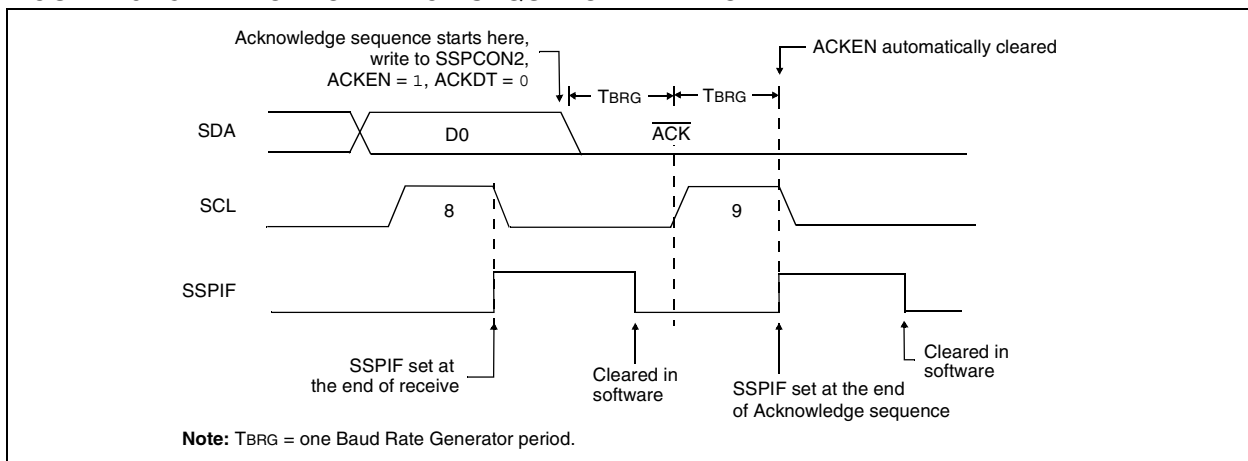
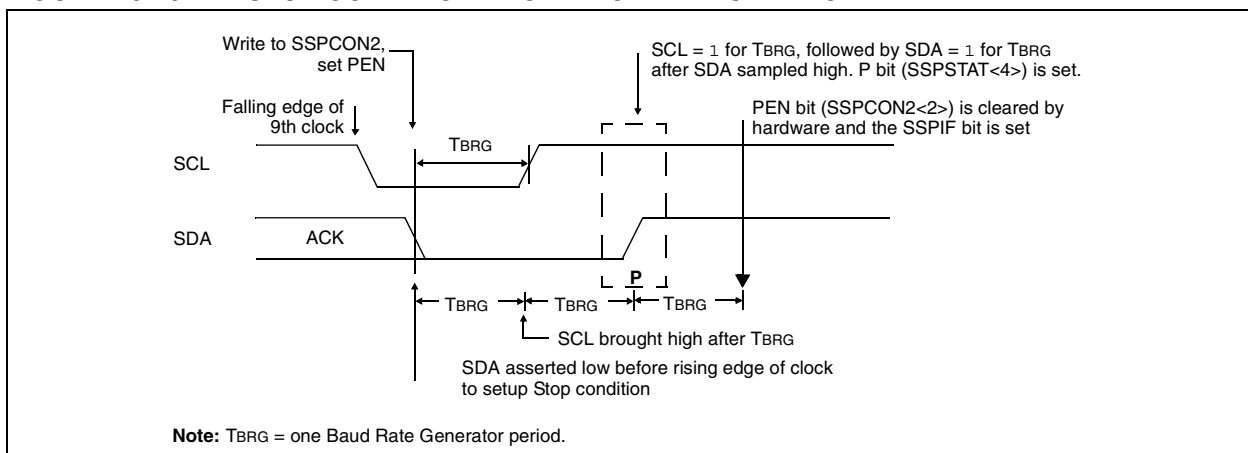

FIGURE 16-26: STOP CONDITION RECEIVE OR TRANSMIT MODE



16.4.14 SLEEP OPERATION

While in Sleep mode, the I²C module can receive addresses or data and when an address match or complete byte transfer occurs, wake the processor from Sleep (if the MSSP interrupt is enabled).

16.4.15 EFFECTS OF A RESET

A Reset disables the MSSP module and terminates the current transfer.

16.4.16 MULTI-MASTER MODE

In Multi-Master mode, the interrupt generation on the detection of the Start and Stop conditions allows the determination of when the bus is free. The Stop (P) and Start (S) bits are cleared from a Reset or when the MSSP module is disabled. Control of the I²C bus may be taken when the P bit (SSPSTAT<4>) is set, or the bus is Idle, with both the S and P bits clear. When the bus is busy, enabling the MSSP interrupt will generate the interrupt when the Stop condition occurs.

In multi-master operation, the SDA line must be monitored for arbitration to see if the signal level is the expected output level. This check is performed in hardware with the result placed in the BCLIF bit.

The states where arbitration can be lost are:

- Address Transfer
- Data Transfer
- A Start Condition
- A Repeated Start Condition
- An Acknowledge Condition

16.4.17 MULTI-MASTER COMMUNICATION, BUS COLLISION AND BUS ARBITRATION

Multi-Master mode support is achieved by bus arbitration. When the master outputs address/data bits onto the SDA pin, arbitration takes place when the master outputs a '1' on SDA by letting SDA float high, and another master asserts a '0'. When the SCL pin floats high, data should be stable. If the expected data on SDA is a '1' and the data sampled on the SDA pin = 0, then a bus collision has taken place. The master will set the Bus Collision Interrupt Flag, BCLIF and reset the I²C port to its Idle state (Figure 16-27).

If a transmit was in progress when the bus collision occurred, the transmission is halted, the BF flag is cleared, the SDA and SCL lines are deasserted and the SSPBUF can be written to. When the user services the bus collision Interrupt Service Routine and if the I²C bus is free, the user can resume communication by asserting a Start condition.

If a Start, Repeated Start, Stop or Acknowledge condition was in progress when the bus collision occurred, the condition is aborted, the SDA and SCL lines are deasserted and the respective control bits in the SSPCON2 register are cleared. When the user services the bus collision Interrupt Service Routine and if the I²C bus is free, the user can resume communication by asserting a Start condition.

The master will continue to monitor the SDA and SCL pins. If a Stop condition occurs, the SSPIF bit will be set.

A write to the SSPBUF will start the transmission of data at the first data bit regardless of where the transmitter left off when the bus collision occurred.

In Multi-Master mode, the interrupt generation on the detection of Start and Stop conditions allows the determination of when the bus is free. Control of the I²C bus can be taken when the P bit is set in the SSPSTAT register, or the bus is Idle and the S and P bits are cleared.

FIGURE 16-27: BUS COLLISION TIMING FOR TRANSMIT AND ACKNOWLEDGE

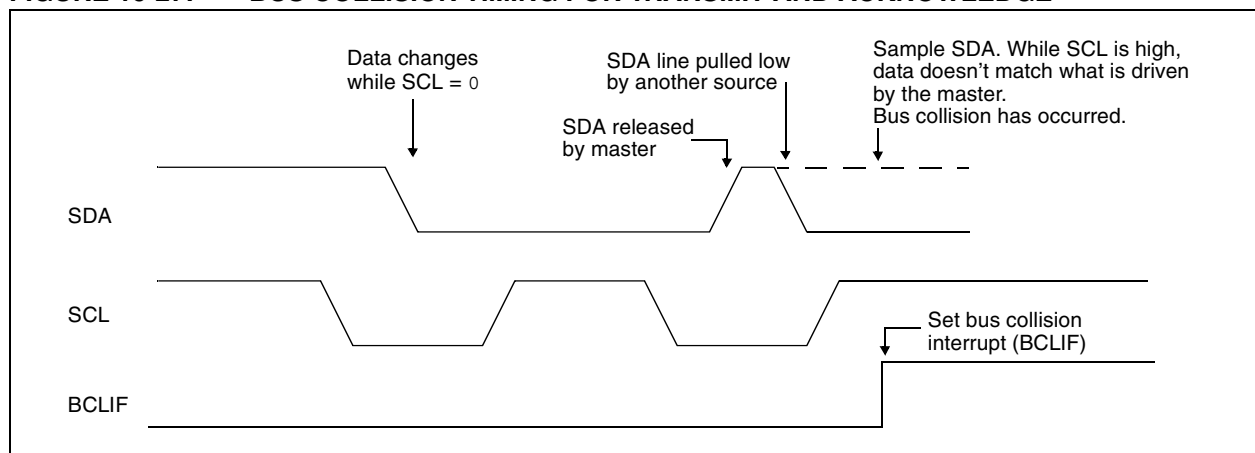

PIC18F85J90 FAMILY

16.4.17.1 Bus Collision During a Start Condition

During a Start condition, a bus collision occurs if:

- SDA or SCL are sampled low at the beginning of the Start condition (Figure 16-28).
- SCL is sampled low before SDA is asserted low (Figure 16-29).

During a Start condition, both the SDA and the SCL pins are monitored.

If the SDA pin is already low, or the SCL pin is already low, then all of the following occur:

- the Start condition is aborted;
- the BCLIF flag is set; and
- the MSSP module is reset to its Idle state (Figure 16-28).

The Start condition begins with the SDA and SCL pins deasserted. When the SDA pin is sampled high, the Baud Rate Generator is loaded from SSPADD<6:0> and counts down to '0'. If the SCL pin is sampled low while SDA is high, a bus collision occurs, because it is assumed that another master is attempting to drive a data '1' during the Start condition.

If the SDA pin is sampled low during this count, the BRG is reset and the SDA line is asserted early (Figure 16-30). If, however, a '1' is sampled on the SDA pin, the SDA pin is asserted low at the end of the BRG count. The Baud Rate Generator is then reloaded and counts down to '0'. If the SCL pin is sampled as '0' during this time, a bus collision does not occur. At the end of the BRG count, the SCL pin is asserted low.

Note: The reason that bus collision is not a factor during a Start condition is that no two bus masters can assert a Start condition at the exact same time. Therefore, one master will always assert SDA before the other. This condition does not cause a bus collision because the two masters must be allowed to arbitrate the first address following the Start condition. If the address is the same, arbitration must be allowed to continue into the data portion, Repeated Start or Stop conditions.

FIGURE 16-28: BUS COLLISION DURING START CONDITION (SDA ONLY)

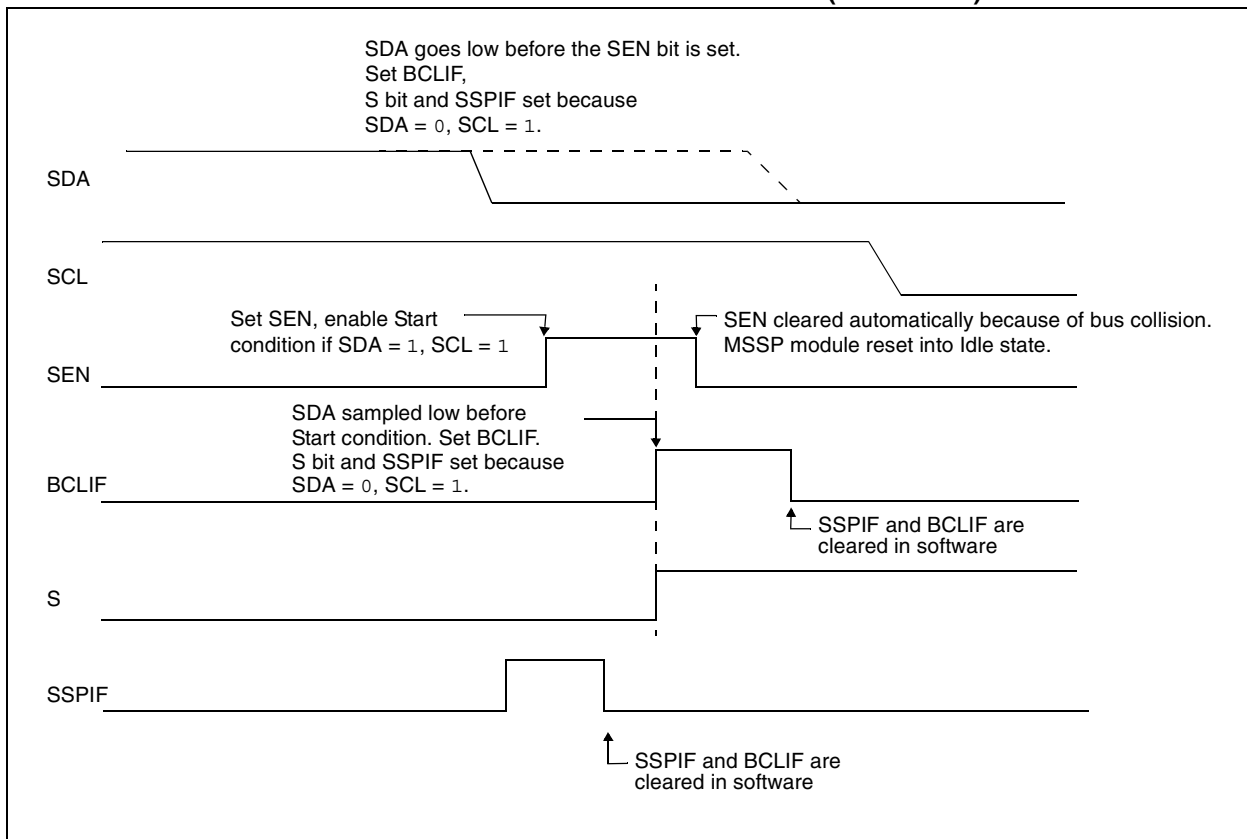

PIC18F85J90 FAMILY

FIGURE 16-29: BUS COLLISION DURING START CONDITION (SCL = 0)

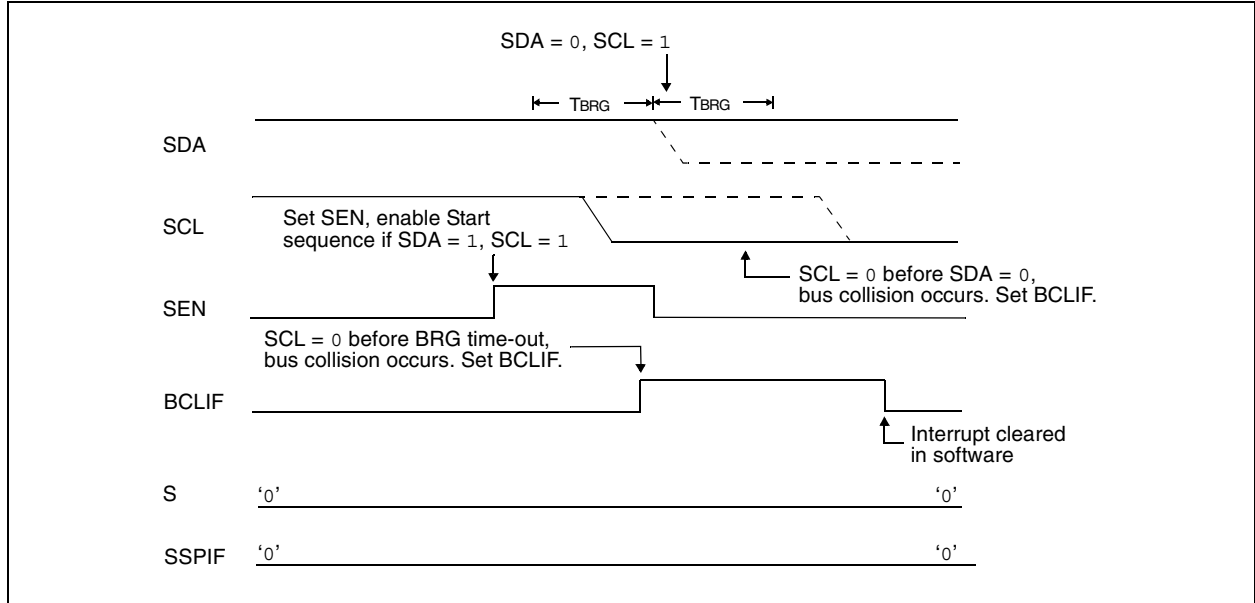
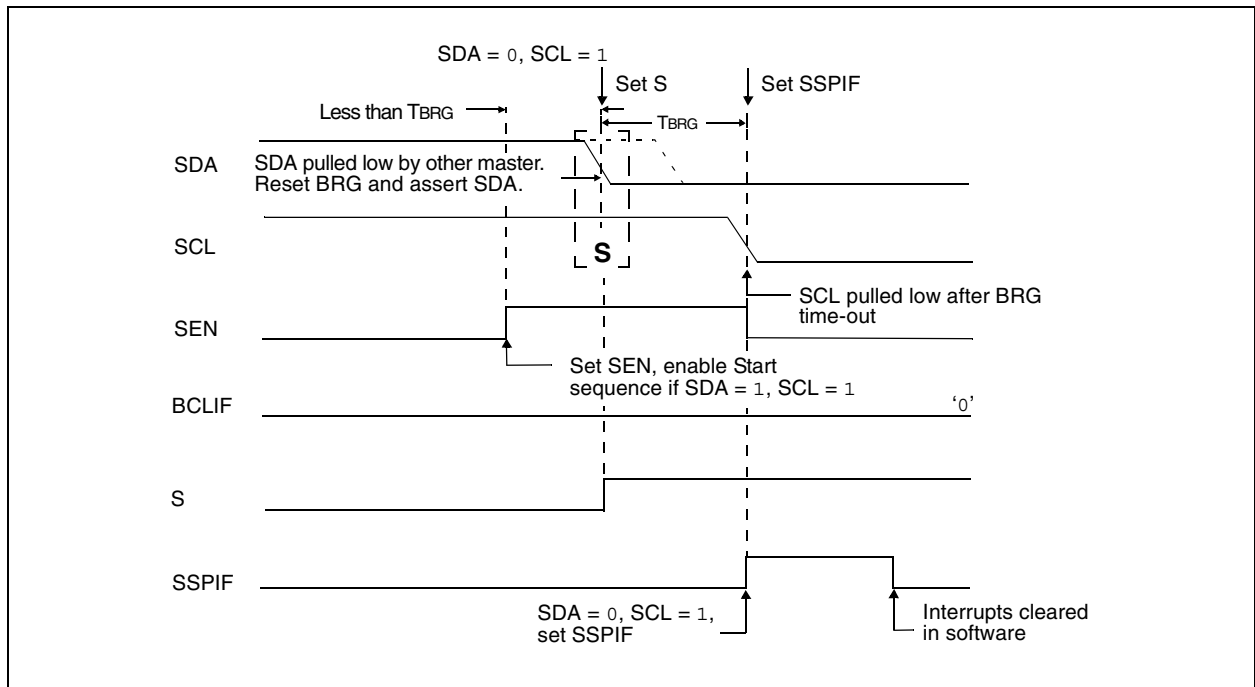

FIGURE 16-30: BRG RESET DUE TO SDA ARBITRATION DURING START CONDITION



PIC18F85J90 FAMILY

16.4.17.2 Bus Collision During a Repeated Start Condition

During a Repeated Start condition, a bus collision occurs if:

- A low level is sampled on SDA when SCL goes from low level to high level.
- SCL goes low before SDA is asserted low, indicating that another master is attempting to transmit a data '1'.

When the user deasserts SDA and the pin is allowed to float high, the BRG is loaded with SSPADD<6:0> and counts down to '0'. The SCL pin is then deasserted and when sampled high, the SDA pin is sampled.

If SDA is low, a bus collision has occurred (i.e., another master is attempting to transmit a data '0', see Figure 16-31). If SDA is sampled high, the BRG is reloaded and begins counting. If SDA goes from high-to-low before the BRG times out, no bus collision occurs because no two masters can assert SDA at exactly the same time.

If SCL goes from high-to-low before the BRG times out and SDA has not already been asserted, a bus collision occurs. In this case, another master is attempting to transmit a data '1' during the Repeated Start condition (see Figure 16-32).

If, at the end of the BRG time-out, both SCL and SDA are still high, the SDA pin is driven low and the BRG is reloaded and begins counting. At the end of the count, regardless of the status of the SCL pin, the SCL pin is driven low and the Repeated Start condition is complete.

FIGURE 16-31: BUS COLLISION DURING A REPEATED START CONDITION (CASE 1)

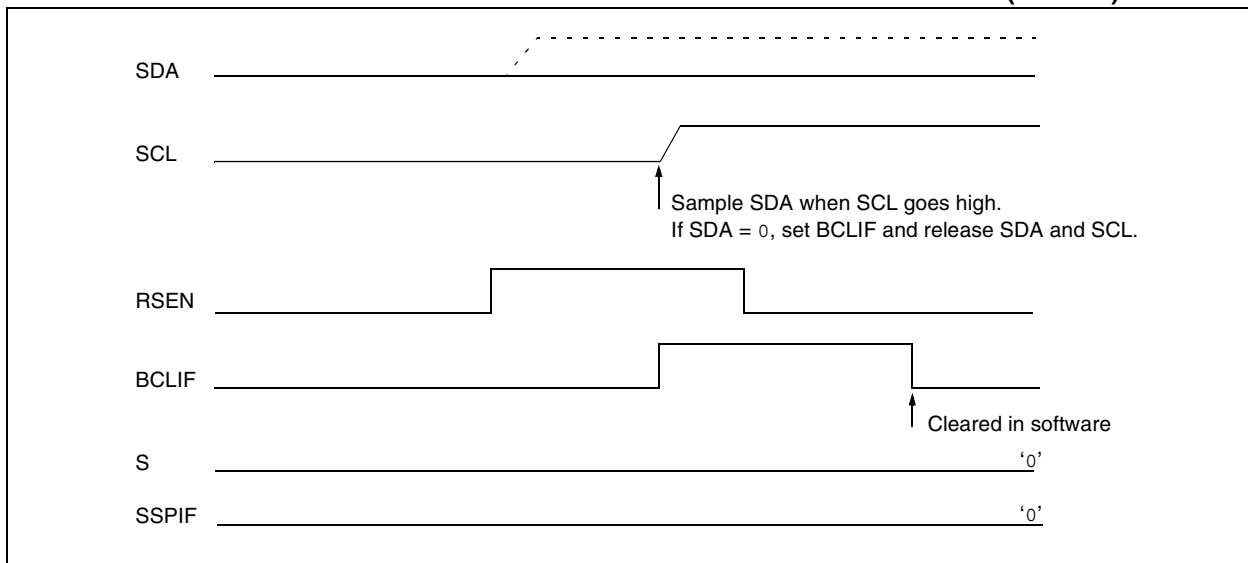
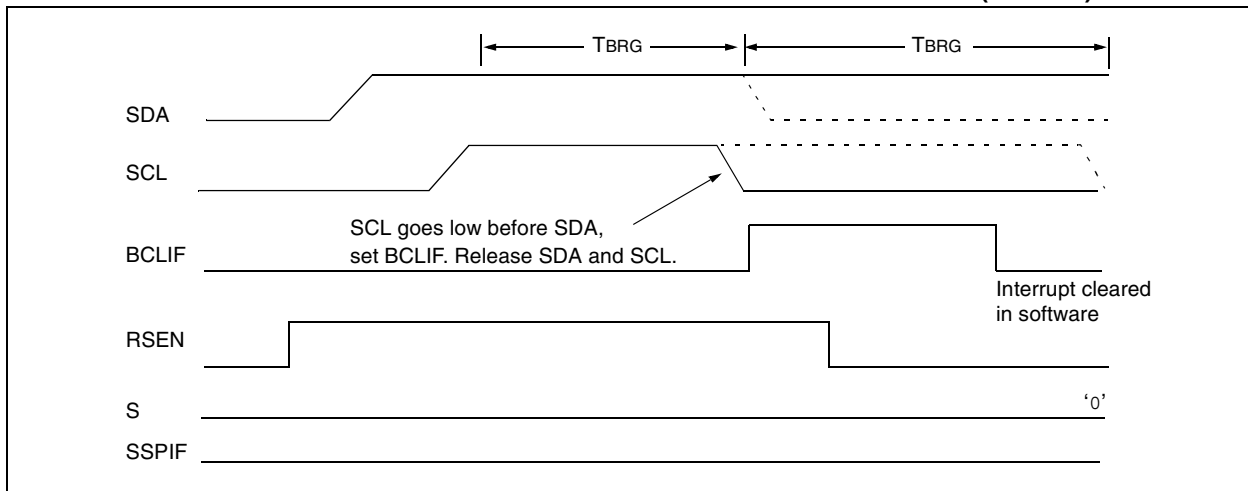

FIGURE 16-32: BUS COLLISION DURING REPEATED START CONDITION (CASE 2)



PIC18F85J90 FAMILY

16.4.17.3 Bus Collision During a Stop Condition

Bus collision occurs during a Stop condition if:

- After the SDA pin has been deasserted and allowed to float high, SDA is sampled low after the BRG has timed out.
- After the SCL pin is deasserted, SCL is sampled low before SDA goes high.

The Stop condition begins with SDA asserted low. When SDA is sampled low, the SCL pin is allowed to float. When the pin is sampled high (clock arbitration), the Baud Rate Generator is loaded with SSPADD<6:0> and counts down to '0'. After the BRG times out, SDA is sampled. If SDA is sampled low, a bus collision has occurred. This is due to another master attempting to drive a data '0' (Figure 16-33). If the SCL pin is sampled low before SDA is allowed to float high, a bus collision occurs. This is another case of another master attempting to drive a data '0' (Figure 16-34).

FIGURE 16-33: BUS COLLISION DURING A STOP CONDITION (CASE 1)

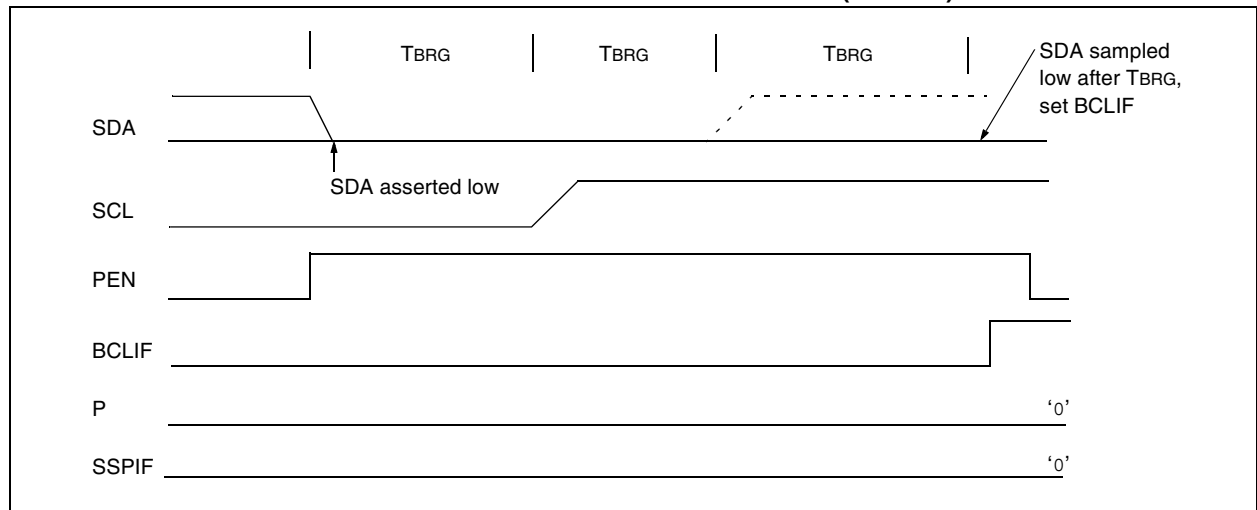
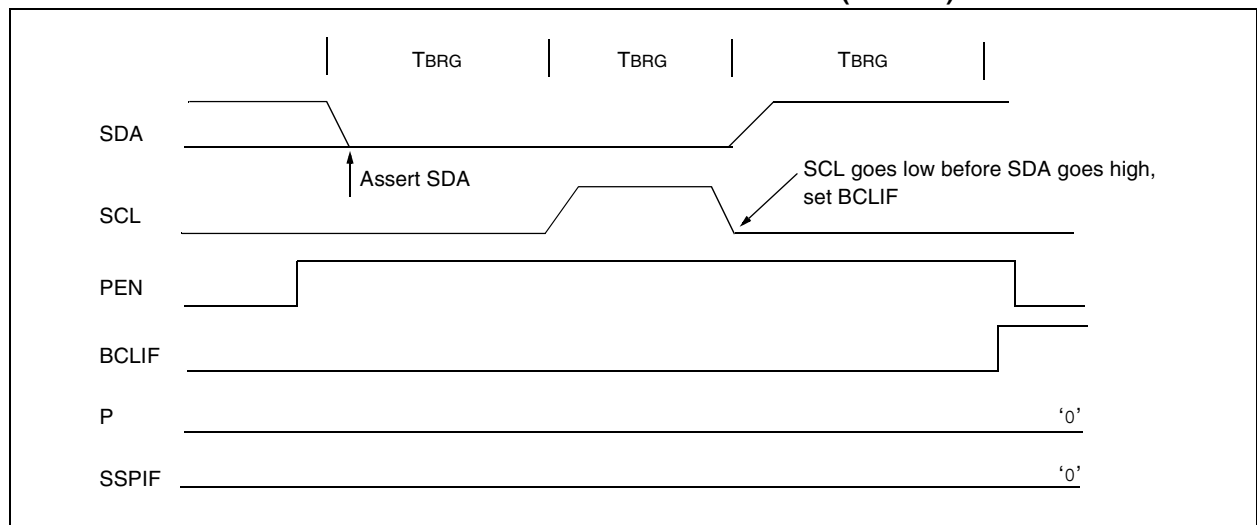

FIGURE 16-34: BUS COLLISION DURING A STOP CONDITION (CASE 2)



PIC18F85J90 FAMILY

TABLE 16-4: REGISTERS ASSOCIATED WITH I²C™ OPERATION

Name	Bit 7	Bit 6	Bit 5	Bit 4	Bit 3	Bit 2	Bit 1	Bit 0	Reset Values on Page
INTCON	GIE/GIEH	PEIE/GIEL	TMR0IE	INT0IE	RBIE	TMR0IF	INT0IF	RBIF	51
PIR1	—	ADIF	RC1IF	TX1IF	SSPIF	—	TMR2IF	TMR1IF	54
PIE1	—	ADIE	RC1IE	TX1IE	SSPIE	—	TMR2IE	TMR1IE	54
IPR1	—	ADIP	RC1IP	TX1IP	SSPIP	—	TMR2IP	TMR1IP	54
PIR2	OSCFIF	CMIF	—	—	BCLIF	LVDIF	TMR3IF	—	54
PIE2	OSCFIE	CMIE	—	—	BCLIE	LVDIE	TMR3IE	—	54
IPR2	OSCFIP	CMIP	—	—	BCLIP	LVDIP	TMR3IP	—	54
TRISC	TRISC7	TRISC6	TRISC5	TRISC4	TRISC3	TRISC2	TRISC1	TRISC0	54
SSPBUF	MSSP Receive Buffer/Transmit Register								52
SSPADD	MSSP Address Register (I ² C™ Slave mode), MSSP Baud Rate Reload Register (I ² C Master mode)								52
SSPCON1	WCOL	SSPOV	SSPEN	CKP	SSPM3	SSPM2	SSPM1	SSPM0	52
SSPCON2	GCEN	ACKSTAT	ACKDT	ACKEN	RCEN	PEN	RSEN	SEN	52
	GCEN	ACKSTAT	ADMSK5 ⁽¹⁾	ADMSK4 ⁽¹⁾	ADMSK3 ⁽¹⁾	ADMSK2 ⁽¹⁾	ADMSK1 ⁽¹⁾	SEN	
SSPSTAT	SMP	CKE	D/ \bar{A}	P	S	R/ \bar{W}	UA	BF	52

Legend: — = unimplemented, read as '0'. Shaded cells are not used by the MSSP module in I²C™ mode.

Note 1: Alternate bit definitions for use in I²C Slave mode operations only.

17.0 ENHANCED UNIVERSAL SYNCHRONOUS ASYNCHRONOUS RECEIVER TRANSMITTER (EUSART)

PIC18F85J90 family devices have three serial I/O modules: the MSSP module, discussed in the previous chapter and two Universal Synchronous Asynchronous Receiver Transmitter (USART) modules. (Generically, the USART is also known as a Serial Communications Interface or SCI.) The USART can be configured as a full-duplex asynchronous system that can communicate with peripheral devices, such as CRT terminals and personal computers. It can also be configured as a half-duplex synchronous system that can communicate with peripheral devices, such as A/D or D/A integrated circuits, serial EEPROMs, etc.

There are two distinct implementations of the USART module in these devices: the Enhanced USART (EUSART) discussed here and the Addressable USART discussed in the next chapter. For this device family, USART1 always refers to the EUSART, while USART2 is always the AUSART.

The EUSART and AUSART modules implement the same core features for serial communications; their basic operation is essentially the same. The EUSART module provides additional features, including Automatic Baud Rate Detection and calibration, automatic wake-up on Sync Break reception and 12-bit Break character transmit. These features make it ideally suited for use in Local Interconnect Network bus (LIN bus) systems.

The EUSART can be configured in the following modes:

- Asynchronous (full-duplex) with:
 - Auto-wake-up on character reception
 - Auto-baud calibration
 - 12-bit Break character transmission
- Synchronous – Master (half-duplex) with selectable clock polarity
- Synchronous – Slave (half-duplex) with selectable clock polarity

The pins of the EUSART are multiplexed with the functions of PORTC (RC6/TX1/CK1/SEG27 and RC7/RX1/DT1/SEG28). In order to configure these pins as an EUSART:

- bit SPEN (RCSTA1<7>) must be set (= 1)
- bit TRISC<7> must be set (= 1)
- bit TRISC<6> must be set (= 1)

Note: The EUSART control will automatically reconfigure the pin from input to output as needed.

The driver for the TX1 output pin can also be optionally configured as an open-drain output. This feature allows the voltage level on the pin to be pulled to a higher level through an external pull-up resistor, and allows the output to communicate with external circuits without the need for additional level shifters.

The open-drain output option is controlled by the U1OD bit (LATG<6>). Setting the bit configures the pin for open-drain operation.

17.1 Control Registers

The operation of the Enhanced USART module is controlled through three registers:

- Transmit Status and Control Register 1 (TXSTA1)
- Receive Status and Control Register 1 (RCSTA1)
- Baud Rate Control Register 1 (BAUDCON1)

The registers are described in Register 17-1, Register 17-2 and Register 17-3.

PIC18F85J90 FAMILY

REGISTER 17-1: TXSTA1: EUSART TRANSMIT STATUS AND CONTROL REGISTER

R/W-0	R/W-0	R/W-0	R/W-0	R/W-0	R/W-0	R-1	R/W-0
CSRC	TX9	TXEN ⁽¹⁾	SYNC	SENDB	BRGH	TRMT	TX9D
bit 7							bit 0

Legend:

R = Readable bit

W = Writable bit

U = Unimplemented bit, read as '0'

-n = Value at POR

'1' = Bit is set

'0' = Bit is cleared

x = Bit is unknown

- bit 7 **CSRC:** Clock Source Select bit
Asynchronous mode:
Don't care.
Synchronous mode:
1 = Master mode (clock generated internally from BRG)
0 = Slave mode (clock from external source)
- bit 6 **TX9:** 9-Bit Transmit Enable bit
1 = Selects 9-bit transmission
0 = Selects 8-bit transmission
- bit 5 **TXEN:** Transmit Enable bit⁽¹⁾
1 = Transmit enabled
0 = Transmit disabled
- bit 4 **SYNC:** AUSART Mode Select bit
1 = Synchronous mode
0 = Asynchronous mode
- bit 3 **SENDB:** Send Break Character bit
Asynchronous mode:
1 = Send Sync Break on next transmission (cleared by hardware upon completion)
0 = Sync Break transmission completed
Synchronous mode:
Don't care.
- bit 2 **BRGH:** High Baud Rate Select bit
Asynchronous mode:
1 = High speed
0 = Low speed
Synchronous mode:
Unused in this mode.
- bit 1 **TRMT:** Transmit Shift Register Status bit
1 = TSR empty
0 = TSR full
- bit 0 **TX9D:** 9th bit of Transmit Data
Can be address/data bit or a parity bit.

Note 1: SREN/CREN overrides TXEN in Sync mode.

PIC18F85J90 FAMILY

REGISTER 17-2: RCSTA1: EUSART RECEIVE STATUS AND CONTROL REGISTER

R/W-0	R/W-0	R/W-0	R/W-0	R/W-0	R-0	R-0	R-x
SPEN	RX9	SREN	CREN	ADDEN	FERR	OERR	RX9D
bit 7							bit 0

Legend:

R = Readable bit	W = Writable bit	U = Unimplemented bit, read as '0'
-n = Value at POR	'1' = Bit is set	'0' = Bit is cleared
		x = Bit is unknown

- bit 7 **SPEN:** Serial Port Enable bit
 1 = Serial port enabled (configures RX1/DT1 and TX1/CK1 pins as serial port pins)
 0 = Serial port disabled (held in Reset)

- bit 6 **RX9:** 9-Bit Receive Enable bit
 1 = Selects 9-bit reception
 0 = Selects 8-bit reception

- bit 5 **SREN:** Single Receive Enable bit
 Asynchronous mode:
 Don't care.
 Synchronous mode – Master:
 1 = Enables single receive
 0 = Disables single receive
 This bit is cleared after reception is complete.
 Synchronous mode – Slave:
 Don't care.

- bit 4 **CREN:** Continuous Receive Enable bit
 Asynchronous mode:
 1 = Enables receiver
 0 = Disables receiver
 Synchronous mode:
 1 = Enables continuous receive until enable bit CREN is cleared (CREN overrides SREN)
 0 = Disables continuous receive

- bit 3 **ADDEN:** Address Detect Enable bit
 Asynchronous mode 9-bit (RX9 = 1):
 1 = Enables address detection, enables interrupt and loads the receive buffer when RSR<8> is set
 0 = Disables address detection, all bytes are received and ninth bit can be used as parity bit
 Asynchronous mode 9-bit (RX9 = 0):
 Don't care.

- bit 2 **FERR:** Framing Error bit
 1 = Framing error (can be updated by reading RCREG1 register and receiving next valid byte)
 0 = No framing error

- bit 1 **OERR:** Overrun Error bit
 1 = Overrun error (can be cleared by clearing bit CREN)
 0 = No overrun error

- bit 0 **RX9D:** 9th bit of Received Data
 This can be address/data bit or a parity bit and must be calculated by user firmware.

PIC18F85J90 FAMILY

REGISTER 17-3: BAUDCON1: BAUD RATE CONTROL REGISTER 1

R/W-0	R-1	U-0	R/W-0	R/W-0	U-0	R/W-0	R/W-0
ABDOVF	RCMT	—	SCKP	BRG16	—	WUE	ABDEN
bit 7							bit 0

Legend:

R = Readable bit W = Writable bit U = Unimplemented bit, read as '0'
 -n = Value at POR '1' = Bit is set '0' = Bit is cleared x = Bit is unknown

- bit 7 **ABDOVF**: Auto-Baud Acquisition Rollover Status bit
 1 = A BRG rollover has occurred during Auto-Baud Rate Detect mode
 (must be cleared in software)
 0 = No BRG rollover has occurred
- bit 6 **RCMT**: Receive Operation Idle Status bit
 1 = Receive operation is Idle
 0 = Receive operation is active
- bit 5 **Unimplemented**: Read as '0'
- bit 4 **SCKP**: Synchronous Clock Polarity Select bit
Asynchronous mode:
 Unused in this mode.
Synchronous mode:
 1 = Idle state for clock (CK1) is a high level
 0 = Idle state for clock (CK1) is a low level
- bit 3 **BRG16**: 16-Bit Baud Rate Register Enable bit
 1 = 16-bit Baud Rate Generator – SPBRGH1 and SPBRG1
 0 = 8-bit Baud Rate Generator – SPBRG1 only (Compatible mode), SPBRGH1 value ignored
- bit 2 **Unimplemented**: Read as '0'
- bit 1 **WUE**: Wake-up Enable bit
Asynchronous mode:
 1 = EUSART will continue to sample the RX1 pin – interrupt generated on falling edge; bit cleared in hardware on following rising edge
 0 = RX1 pin not monitored or rising edge detected
Synchronous mode:
 Unused in this mode.
- bit 0 **ABDEN**: Auto-Baud Detect Enable bit
Asynchronous mode:
 1 = Enable baud rate measurement on the next character. Requires reception of a Sync field (55h); cleared in hardware upon completion.
 0 = Baud rate measurement disabled or completed
Synchronous mode:
 Unused in this mode.

17.2 EUSART Baud Rate Generator (BRG)

The BRG is a dedicated, 8-bit or 16-bit generator that supports both the Asynchronous and Synchronous modes of the EUSART. By default, the BRG operates in 8-bit mode; setting the BRG16 bit (BAUDCON1<3>) selects 16-bit mode.

The SPBRGH1:SPBRG1 register pair controls the period of a free-running timer. In Asynchronous mode, BRGH (TXSTA1<2>) and BRG16 (BAUDCON1<3>) bits also control the baud rate. In Synchronous mode, BRGH is ignored. Table 17-1 shows the formula for computation of the baud rate for different EUSART modes that only apply in Master mode (internally generated clock).

Given the desired baud rate and FOSC, the nearest integer value for the SPBRGH1:SPBRG1 registers can be calculated using the formulas in Table 17-1. From this, the error in baud rate can be determined. An example calculation is shown in Example 17-1. Typical baud rates and error values for the various Asynchronous modes are shown in Table 17-2. It may be advanta-

geous to use the high baud rate (BRGH = 1) or the 16-bit BRG to reduce the baud rate error, or achieve a slow baud rate for a fast oscillator frequency.

Writing a new value to the SPBRGH1:SPBRG1 registers causes the BRG timer to be reset (or cleared). This ensures the BRG does not wait for a timer overflow before outputting the new baud rate.

17.2.1 OPERATION IN POWER-MANAGED MODES

The device clock is used to generate the desired baud rate. When one of the power-managed modes is entered, the new clock source may be operating at a different frequency. This may require an adjustment to the value in the SPBRG1 register pair.

17.2.2 SAMPLING

The data on the RX1 pin is sampled three times by a majority detect circuit to determine if a high or a low level is present at the RX1 pin.

TABLE 17-1: BAUD RATE FORMULAS

Configuration Bits			BRG/EUSART Mode	Baud Rate Formula
SYNC	BRG16	BRGH		
0	0	0	8-bit/Asynchronous	$F_{OSC}/[64(n+1)]$
0	0	1	8-bit/Asynchronous	$F_{OSC}/[16(n+1)]$
0	1	0	16-bit/Asynchronous	
0	1	1	16-bit/Asynchronous	$F_{OSC}/[4(n+1)]$
1	0	x	8-bit/Synchronous	
1	1	x	16-bit/Synchronous	

Legend: x = Don't care, n = Value of SPBRGH1:SPBRG1 register pair

EXAMPLE 17-1: CALCULATING BAUD RATE ERROR

For a device with FOSC of 16 MHz, desired baud rate of 9600, Asynchronous mode, 8-bit BRG:	
Desired Baud Rate	= $F_{OSC}/(64 ([SPBRGH1:SPBRG1] + 1))$
Solving for SPBRGH1:SPBRG1:	
X	= $((F_{OSC}/\text{Desired Baud Rate})/64) - 1$
	= $((16000000/9600)/64) - 1$
	= $[25.042] = 25$
Calculated Baud Rate	= $16000000/(64(25+1))$
	= 9615
Error	= $(\text{Calculated Baud Rate} - \text{Desired Baud Rate})/\text{Desired Baud Rate}$
	= $(9615 - 9600)/9600 = 0.16\%$

TABLE 17-2: REGISTERS ASSOCIATED WITH THE BAUD RATE GENERATOR

Name	Bit 7	Bit 6	Bit 5	Bit 4	Bit 3	Bit 2	Bit 1	Bit 0	Reset Values on Page
TXSTA1	CSRC	TX9	TXEN	SYNC	SENDB	BRGH	TRMT	TX9D	53
RCSTA1	SPEN	RX9	SREN	CREN	ADDEN	FERR	OERR	RX9D	53
BAUDCON1	ABDOVF	RCMT	—	SCKP	BRG16	—	WUE	ABDEN	55
SPBRGH1	EUSART Baud Rate Generator Register High Byte								55
SPBRG1	EUSART Baud Rate Generator Register Low Byte								53

Legend: — = unimplemented, read as '0'. Shaded cells are not used by the BRG.

PIC18F85J90 FAMILY

TABLE 17-3: BAUD RATES FOR ASYNCHRONOUS MODES

BAUD RATE (K)	SYNC = 0, BRGH = 0, BRG16 = 0											
	Fosc = 40.000 MHz			Fosc = 20.000 MHz			Fosc = 10.000 MHz			Fosc = 8.000 MHz		
	Actual Rate (K)	% Error	SPBRG value (decimal)	Actual Rate (K)	% Error	SPBRG value (decimal)	Actual Rate (K)	% Error	SPBRG value (decimal)	Actual Rate (K)	% Error	SPBRG value (decimal)
0.3	—	—	—	—	—	—	—	—	—	—	—	—
1.2	—	—	—	1.221	1.73	255	1.202	0.16	129	1.201	-0.16	103
2.4	2.441	1.73	255	2.404	0.16	129	2.404	0.16	64	2.403	-0.16	51
9.6	9.615	0.16	64	9.766	1.73	31	9.766	1.73	15	9.615	-0.16	12
19.2	19.531	1.73	31	19.531	1.73	15	19.531	1.73	7	—	—	—
57.6	56.818	-1.36	10	62.500	8.51	4	52.083	-9.58	2	—	—	—
115.2	125.000	8.51	4	104.167	-9.58	2	78.125	-32.18	1	—	—	—

BAUD RATE (K)	SYNC = 0, BRGH = 0, BRG16 = 0								
	Fosc = 4.000 MHz			Fosc = 2.000 MHz			Fosc = 1.000 MHz		
	Actual Rate (K)	% Error	SPBRG value (decimal)	Actual Rate (K)	% Error	SPBRG value (decimal)	Actual Rate (K)	% Error	SPBRG value (decimal)
0.3	0.300	0.16	207	0.300	-0.16	103	0.300	-0.16	51
1.2	1.202	0.16	51	1.201	-0.16	25	1.201	-0.16	12
2.4	2.404	0.16	25	2.403	-0.16	12	—	—	—
9.6	8.929	-6.99	6	—	—	—	—	—	—
19.2	20.833	8.51	2	—	—	—	—	—	—
57.6	62.500	8.51	0	—	—	—	—	—	—
115.2	62.500	-45.75	0	—	—	—	—	—	—

BAUD RATE (K)	SYNC = 0, BRGH = 1, BRG16 = 0											
	Fosc = 40.000 MHz			Fosc = 20.000 MHz			Fosc = 10.000 MHz			Fosc = 8.000 MHz		
	Actual Rate (K)	% Error	SPBRG value (decimal)	Actual Rate (K)	% Error	SPBRG value (decimal)	Actual Rate (K)	% Error	SPBRG value (decimal)	Actual Rate (K)	% Error	SPBRG value (decimal)
0.3	—	—	—	—	—	—	—	—	—	—	—	—
1.2	—	—	—	—	—	—	—	—	—	—	—	—
2.4	—	—	—	—	—	—	2.441	1.73	255	2.403	-0.16	207
9.6	9.766	1.73	255	9.615	0.16	129	9.615	0.16	64	9.615	-0.16	51
19.2	19.231	0.16	129	19.231	0.16	64	19.531	1.73	31	19.230	-0.16	25
57.6	58.140	0.94	42	56.818	-1.36	21	56.818	-1.36	10	55.555	3.55	8
115.2	113.636	-1.36	21	113.636	-1.36	10	125.000	8.51	4	—	—	—

BAUD RATE (K)	SYNC = 0, BRGH = 1, BRG16 = 0								
	Fosc = 4.000 MHz			Fosc = 2.000 MHz			Fosc = 1.000 MHz		
	Actual Rate (K)	% Error	SPBRG value (decimal)	Actual Rate (K)	% Error	SPBRG value (decimal)	Actual Rate (K)	% Error	SPBRG value (decimal)
0.3	—	—	—	—	—	—	0.300	-0.16	207
1.2	1.202	0.16	207	1.201	-0.16	103	1.201	-0.16	51
2.4	2.404	0.16	103	2.403	-0.16	51	2.403	-0.16	25
9.6	9.615	0.16	25	9.615	-0.16	12	—	—	—
19.2	19.231	0.16	12	—	—	—	—	—	—
57.6	62.500	8.51	3	—	—	—	—	—	—
115.2	125.000	8.51	1	—	—	—	—	—	—

PIC18F85J90 FAMILY

TABLE 17-3: BAUD RATES FOR ASYNCHRONOUS MODES (CONTINUED)

BAUD RATE (K)	SYNC = 0, BRGH = 0, BRG16 = 1											
	Fosc = 40.000 MHz			Fosc = 20.000 MHz			Fosc = 10.000 MHz			Fosc = 8.000 MHz		
	Actual Rate (K)	% Error	SPBRG value (decimal)	Actual Rate (K)	% Error	SPBRG value (decimal)	Actual Rate (K)	% Error	SPBRG value (decimal)	Actual Rate (K)	% Error	SPBRG value (decimal)
0.3	0.300	0.00	8332	0.300	0.02	4165	0.300	0.02	2082	0.300	-0.04	1665
1.2	1.200	0.02	2082	1.200	-0.03	1041	1.200	-0.03	520	1.201	-0.16	415
2.4	2.402	0.06	1040	2.399	-0.03	520	2.404	0.16	259	2.403	-0.16	207
9.6	9.615	0.16	259	9.615	0.16	129	9.615	0.16	64	9.615	-0.16	51
19.2	19.231	0.16	129	19.231	0.16	64	19.531	1.73	31	19.230	-0.16	25
57.6	58.140	0.94	42	56.818	-1.36	21	56.818	-1.36	10	55.555	3.55	8
115.2	113.636	-1.36	21	113.636	-1.36	10	125.000	8.51	4	—	—	—

BAUD RATE (K)	SYNC = 0, BRGH = 0, BRG16 = 1								
	Fosc = 4.000 MHz			Fosc = 2.000 MHz			Fosc = 1.000 MHz		
	Actual Rate (K)	% Error	SPBRG value (decimal)	Actual Rate (K)	% Error	SPBRG value (decimal)	Actual Rate (K)	% Error	SPBRG value (decimal)
0.3	0.300	0.04	832	0.300	-0.16	415	0.300	-0.16	207
1.2	1.202	0.16	207	1.201	-0.16	103	1.201	-0.16	51
2.4	2.404	0.16	103	2.403	-0.16	51	2.403	-0.16	25
9.6	9.615	0.16	25	9.615	-0.16	12	—	—	—
19.2	19.231	0.16	12	—	—	—	—	—	—
57.6	62.500	8.51	3	—	—	—	—	—	—
115.2	125.000	8.51	1	—	—	—	—	—	—

BAUD RATE (K)	SYNC = 0, BRGH = 1, BRG16 = 1 or SYNC = 1, BRG16 = 1											
	Fosc = 40.000 MHz			Fosc = 20.000 MHz			Fosc = 10.000 MHz			Fosc = 8.000 MHz		
	Actual Rate (K)	% Error	SPBRG value (decimal)	Actual Rate (K)	% Error	SPBRG value (decimal)	Actual Rate (K)	% Error	SPBRG value (decimal)	Actual Rate (K)	% Error	SPBRG value (decimal)
0.3	0.300	0.00	33332	0.300	0.00	16665	0.300	0.00	8332	0.300	-0.01	6665
1.2	1.200	0.00	8332	1.200	0.02	4165	1.200	0.02	2082	1.200	-0.04	1665
2.4	2.400	0.02	4165	2.400	0.02	2082	2.402	0.06	1040	2.400	-0.04	832
9.6	9.606	0.06	1040	9.596	-0.03	520	9.615	0.16	259	9.615	-0.16	207
19.2	19.193	-0.03	520	19.231	0.16	259	19.231	0.16	129	19.230	-0.16	103
57.6	57.803	0.35	172	57.471	-0.22	86	58.140	0.94	42	57.142	0.79	34
115.2	114.943	-0.22	86	116.279	0.94	42	113.636	-1.36	21	117.647	-2.12	16

BAUD RATE (K)	SYNC = 0, BRGH = 1, BRG16 = 1 or SYNC = 1, BRG16 = 1								
	Fosc = 4.000 MHz			Fosc = 2.000 MHz			Fosc = 1.000 MHz		
	Actual Rate (K)	% Error	SPBRG value (decimal)	Actual Rate (K)	% Error	SPBRG value (decimal)	Actual Rate (K)	% Error	SPBRG value (decimal)
0.3	0.300	0.01	3332	0.300	-0.04	1665	0.300	-0.04	832
1.2	1.200	0.04	832	1.201	-0.16	415	1.201	-0.16	207
2.4	2.404	0.16	415	2.403	-0.16	207	2.403	-0.16	103
9.6	9.615	0.16	103	9.615	-0.16	51	9.615	-0.16	25
19.2	19.231	0.16	51	19.230	-0.16	25	19.230	-0.16	12
57.6	58.824	2.12	16	55.555	3.55	8	—	—	—
115.2	111.111	-3.55	8	—	—	—	—	—	—

PIC18F85J90 FAMILY

17.2.3 AUTO-BAUD RATE DETECT

The Enhanced USART module supports the automatic detection and calibration of baud rate. This feature is active only in Asynchronous mode and while the WUE bit is clear.

The automatic baud rate measurement sequence (Figure 17-1) begins whenever a Start bit is received and the ABDEN bit is set. The calculation is self-averaging.

In the Auto-Baud Rate Detect (ABD) mode, the clock to the BRG is reversed. Rather than the BRG clocking the incoming RX1 signal, the RX1 signal is timing the BRG. In ABD mode, the internal Baud Rate Generator is used as a counter to time the bit period of the incoming serial byte stream.

Once the ABDEN bit is set, the state machine will clear the BRG and look for a Start bit. The Auto-Baud Rate Detect must receive a byte with the value, 55h (ASCII “U”, which is also the LIN bus Sync character), in order to calculate the proper bit rate. The measurement is taken over both a low and a high bit time in order to minimize any effects caused by asymmetry of the incoming signal. After a Start bit, the SPBRG1 begins counting up, using the preselected clock source on the first rising edge of RX1. After eight bits on the RX1 pin or the fifth rising edge, an accumulated value totalling the proper BRG period is left in the SPBRGH1:SPBRG1 register pair. Once the 5th edge is seen (this should correspond to the Stop bit), the ABDEN bit is automatically cleared.

If a rollover of the BRG occurs (an overflow from FFFFh to 0000h), the event is trapped by the ABDOVF status bit (BAUDCON1<7>). It is set in hardware by BRG rollovers and can be set or cleared by the user in software. ABD mode remains active after rollover events and the ABDEN bit remains set (Figure 17-2).

While calibrating the baud rate period, the BRG registers are clocked at 1/8th the preconfigured clock rate. Note that the BRG clock will be configured by the BRG16 and BRGH bits. Independent of the BRG16 bit setting, both the SPBRG1 and SPBRGH1 will be used as a 16-bit counter. This allows the user to verify that no carry occurred for 8-bit modes by checking for 00h in the SPBRGH1 register. Refer to Table 17-4 for counter clock rates to the BRG.

While the ABD sequence takes place, the EUSART state machine is held in Idle. The RC1IF interrupt is set once the fifth rising edge on RX1 is detected. The value in the RCREG1 needs to be read to clear the RC1IF interrupt. The contents of RCREG1 should be discarded.

Note 1: If the WUE bit is set with the ABDEN bit, Auto-Baud Rate Detection will occur on the byte *following* the Break character.

2: It is up to the user to determine that the incoming character baud rate is within the range of the selected BRG clock source. Some combinations of oscillator frequency and EUSART baud rates are not possible due to bit error rates. Overall system timing and communication baud rates must be taken into consideration when using the Auto-Baud Rate Detection feature.

TABLE 17-4: BRG COUNTER CLOCK RATES

BRG16	BRGH	BRG Counter Clock
0	0	Fosc/512
0	1	Fosc/128
1	0	Fosc/128
1	1	Fosc/32

Note: During the ABD sequence, SPBRG1 and SPBRGH1 are both used as a 16-bit counter, independent of the BRG16 setting.

17.2.3.1 ABD and EUSART Transmission

Since the BRG clock is reversed during ABD acquisition, the EUSART transmitter cannot be used during ABD. This means that whenever the ABDEN bit is set, TXREG1 cannot be written to. Users should also ensure that ABDEN does not become set during a transmit sequence. Failing to do this may result in unpredictable EUSART operation.

PIC18F85J90 FAMILY

FIGURE 17-1: AUTOMATIC BAUD RATE CALCULATION

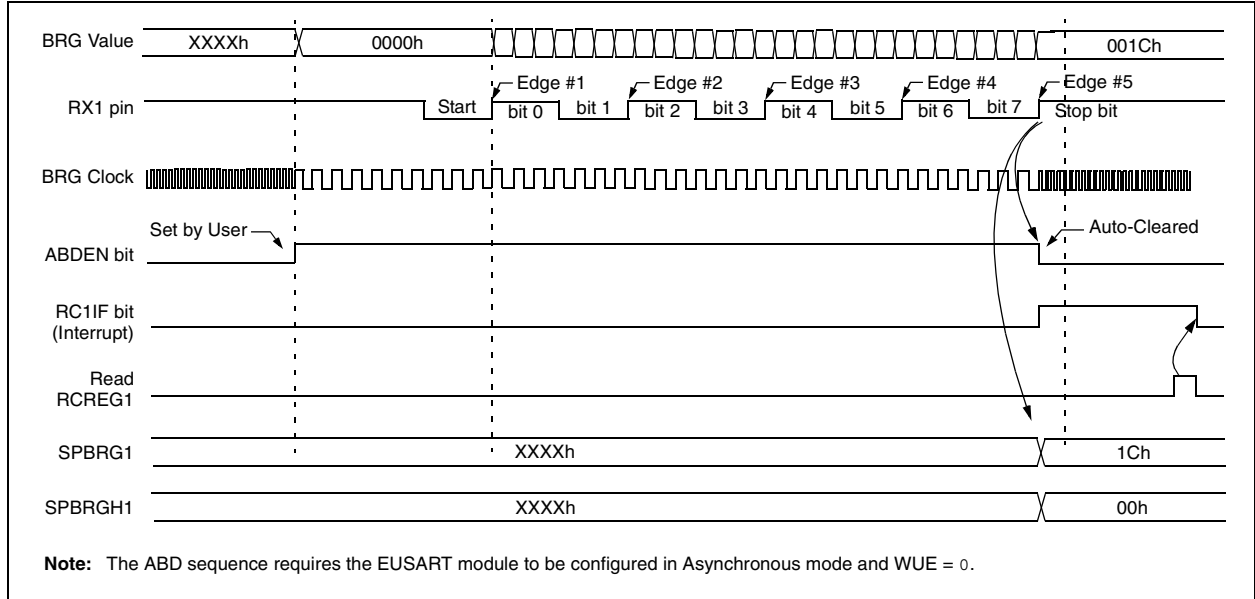
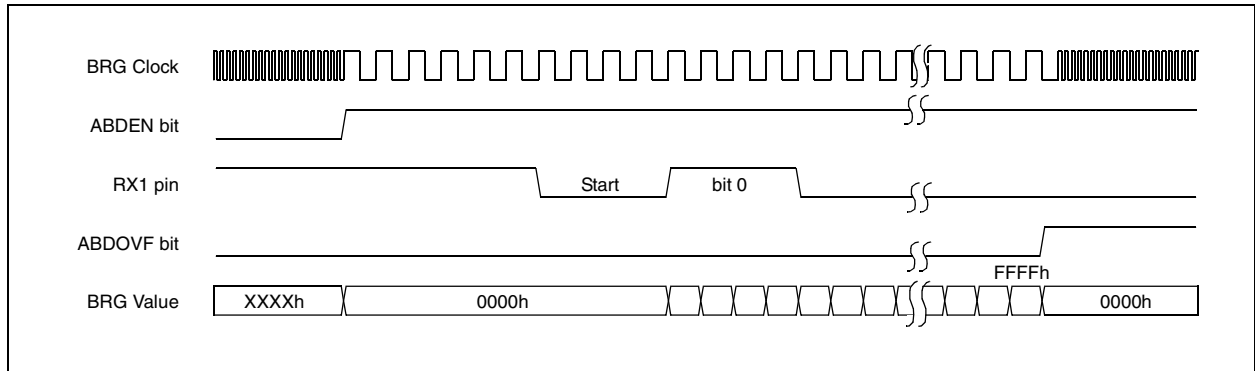

FIGURE 17-2: BRG OVERFLOW SEQUENCE



PIC18F85J90 FAMILY

17.3 EUSART Asynchronous Mode

The Asynchronous mode of operation is selected by clearing the SYNC bit (TXSTA1<4>). In this mode, the EUSART uses standard Non-Return-to-Zero (NRZ) format (one Start bit, eight or nine data bits and one Stop bit). The most common data format is 8 bits. An on-chip dedicated 8-bit/16-bit Baud Rate Generator can be used to derive standard baud rate frequencies from the oscillator.

The EUSART transmits and receives the LSb first. The EUSART's transmitter and receiver are functionally independent, but use the same data format and baud rate. The Baud Rate Generator produces a clock, either x16 or x64 of the bit shift rate, depending on the BRGH and BRG16 bits (TXSTA1<2> and BAUDCON1<3>). Parity is not supported by the hardware but can be implemented in software and stored as the 9th data bit.

When operating in Asynchronous mode, the EUSART module consists of the following important elements:

- Baud Rate Generator
- Sampling Circuit
- Asynchronous Transmitter
- Asynchronous Receiver
- Auto-Wake-up on Sync Break Character
- 12-Bit Break Character Transmit
- Auto-Baud Rate Detection

17.3.1 EUSART ASYNCHRONOUS TRANSMITTER

The EUSART transmitter block diagram is shown in Figure 17-3. The heart of the transmitter is the Transmit (Serial) Shift register (TSR). The Shift register obtains its data from the Read/Write Transmit Buffer register, TXREG1. The TXREG1 register is loaded with data in software. The TSR register is not loaded until the Stop bit has been transmitted from the previous load. As soon as the Stop bit is transmitted, the TSR is loaded with new data from the TXREG1 register (if available).

Once the TXREG1 register transfers the data to the TSR register (occurs in one Tcy), the TXREG1 register is empty and the TX1IF flag bit (PIR1<4>) is set. This interrupt can be enabled or disabled by setting or clearing the interrupt enable bit, TX1IE (PIE1<4>). TX1IF will be set regardless of the state of TX1IE; it cannot be cleared in software. TX1IF is also not cleared immediately upon loading TXREG1, but becomes valid in the second instruction cycle following the load instruction. Polling TX1IF immediately following a load of TXREG1 will return invalid results.

While TX1IF indicates the status of the TXREG1 register, another bit, TRMT (TXSTA1<1>), shows the status of the TSR register. TRMT is a read-only bit which is set when the TSR register is empty. No interrupt logic is tied to this bit so the user has to poll this bit in order to determine if the TSR register is empty.

Note 1: The TSR register is not mapped in data memory so it is not available to the user.

2: Flag bit, TX1IF, is set when enable bit, TXEN, is set.

To set up an Asynchronous Transmission:

1. Initialize the SPBRGH1:SPBRG1 registers for the appropriate baud rate. Set or clear the BRGH and BRG16 bits, as required, to achieve the desired baud rate.
2. Enable the asynchronous serial port by clearing bit SYNC and setting bit SPEN.
3. If interrupts are desired, set enable bit, TX1IE.
4. If 9-bit transmission is desired, set transmit bit, TX9; can be used as address/data bit.
5. Enable the transmission by setting bit, TXEN, which will also set bit, TX1IF.
6. If 9-bit transmission is selected, the ninth bit should be loaded in bit TX9D.
7. Load data to the TXREG1 register (starts transmission).
8. If using interrupts, ensure that the GIE and PEIE bits in the INTCON register (INTCON<7:6>) are set.

FIGURE 17-3: EUSART TRANSMIT BLOCK DIAGRAM

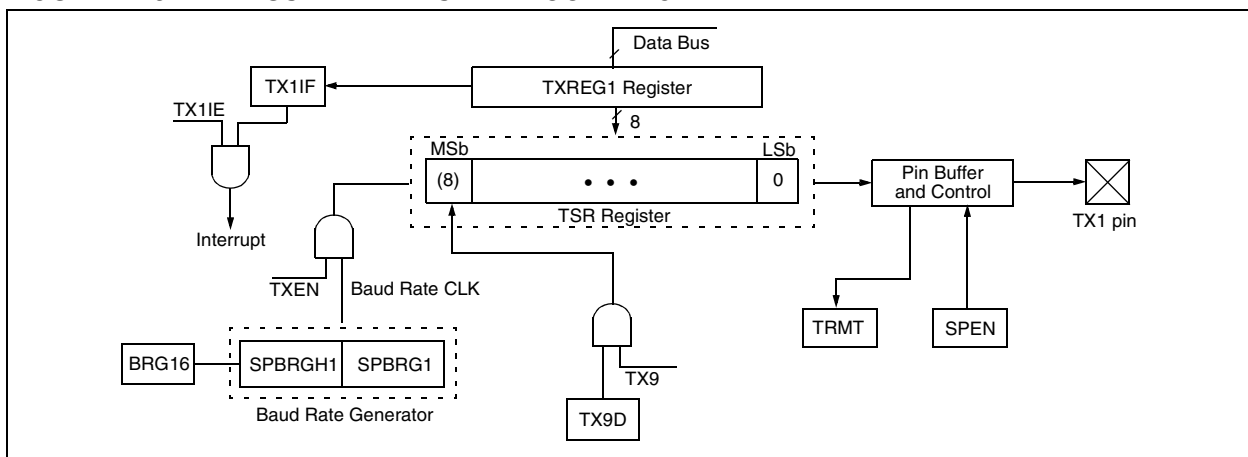

PIC18F85J90 FAMILY

FIGURE 17-4: ASYNCHRONOUS TRANSMISSION

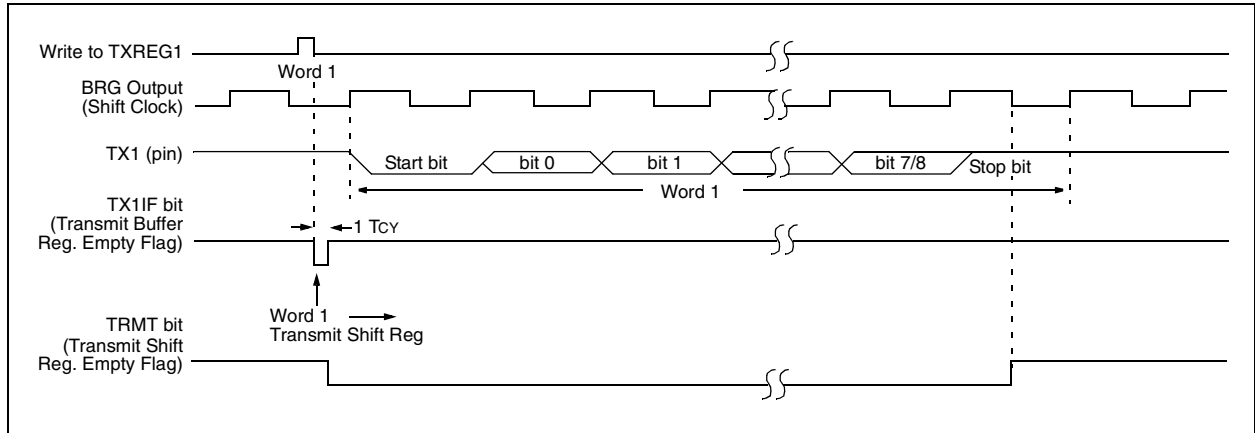

FIGURE 17-5: ASYNCHRONOUS TRANSMISSION (BACK TO BACK)

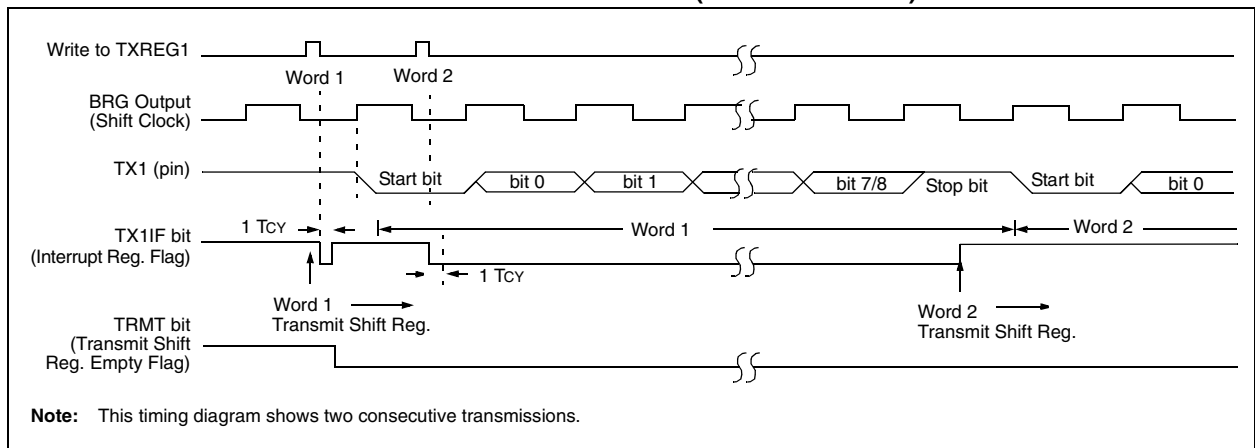

TABLE 17-5: REGISTERS ASSOCIATED WITH ASYNCHRONOUS TRANSMISSION

Name	Bit 7	Bit 6	Bit 5	Bit 4	Bit 3	Bit 2	Bit 1	Bit 0	Reset Values on Page
INTCON	GIE/GIEH	PEIE/GIEL	TMR0IE	INT0IE	RBIE	TMR0IF	INT0IF	RBIF	51
PIR1	—	ADIF	RC1IF	TX1IF	SSPIF	—	TMR2IF	TMR1IF	54
PIE1	—	ADIE	RC1IE	TX1IE	SSPIE	—	TMR2IE	TMR1IE	54
IPR1	—	ADIP	RC1IP	TX1IP	SSPIP	—	TMR2IP	TMR1IP	54
RCSTA1	SPEN	RX9	SREN	CREN	ADDEN	FERR	OERR	RX9D	53
TXREG1	EUSART Transmit Register								53
TXSTA1	CSRC	TX9	TXEN	SYNC	SENDB	BRGH	TRMT	TX9D	53
BAUDCON1	ABDOVF	RCMT	—	SCKP	BRG16	—	WUE	ABDEN	55
SPBRGH1	EUSART Baud Rate Generator Register High Byte								55
SPBRG1	EUSART Baud Rate Generator Register Low Byte								53
LATG	U2OD	U1OD	—	LATG4	LATG3	LATG2	LATG1	LATG0	54

Legend: — = unimplemented locations read as '0'. Shaded cells are not used for asynchronous transmission.

PIC18F85J90 FAMILY

17.3.2 EUSART ASYNCHRONOUS RECEIVER

The receiver block diagram is shown in Figure 17-6. The data is received on the RX1 pin and drives the data recovery block. The data recovery block is actually a high-speed shifter operating at x16 times the baud rate, whereas the main receive serial shifter operates at the bit rate or at FOSC. This mode would typically be used in RS-232 systems.

To set up an Asynchronous Reception:

1. Initialize the SPBRGH1:SPBRG1 registers for the appropriate baud rate. Set or clear the BRGH and BRG16 bits, as required, to achieve the desired baud rate.
2. Enable the asynchronous serial port by clearing bit SYNC and setting bit, SPEN.
3. If interrupts are desired, set enable bit, RC1IE.
4. If 9-bit reception is desired, set bit, RX9.
5. Enable the reception by setting bit, CREN.
6. Flag bit, RC1IF, will be set when reception is complete and an interrupt will be generated if enable bit, RC1IE, was set.
7. Read the RCSTA1 register to get the 9th bit (if enabled) and determine if any error occurred during reception.
8. Read the 8-bit received data by reading the RCREG1 register.
9. If any error occurred, clear the error by clearing enable bit CREN.
10. If using interrupts, ensure that the GIE and PEIE bits in the INTCON register (INTCON<7:6>) are set.

17.3.3 SETTING UP 9-BIT MODE WITH ADDRESS DETECT

This mode would typically be used in RS-485 systems. To set up an Asynchronous Reception with Address Detect Enable:

1. Initialize the SPBRGH1:SPBRG1 registers for the appropriate baud rate. Set or clear the BRGH and BRG16 bits, as required, to achieve the desired baud rate.
2. Enable the asynchronous serial port by clearing the SYNC bit and setting the SPEN bit.
3. If interrupts are required, set the RCEN bit and select the desired priority level with the RC1IP bit.
4. Set the RX9 bit to enable 9-bit reception.
5. Set the ADDEN bit to enable address detect.
6. Enable reception by setting the CREN bit.
7. The RC1IF bit will be set when reception is complete. The interrupt will be Acknowledged if the RC1IE and GIE bits are set.
8. Read the RCSTA1 register to determine if any error occurred during reception, as well as read bit 9 of data (if applicable).
9. Read RCREG1 to determine if the device is being addressed.
10. If any error occurred, clear the CREN bit.
11. If the device has been addressed, clear the ADDEN bit to allow all received data into the receive buffer and interrupt the CPU.

FIGURE 17-6: EUSART RECEIVE BLOCK DIAGRAM

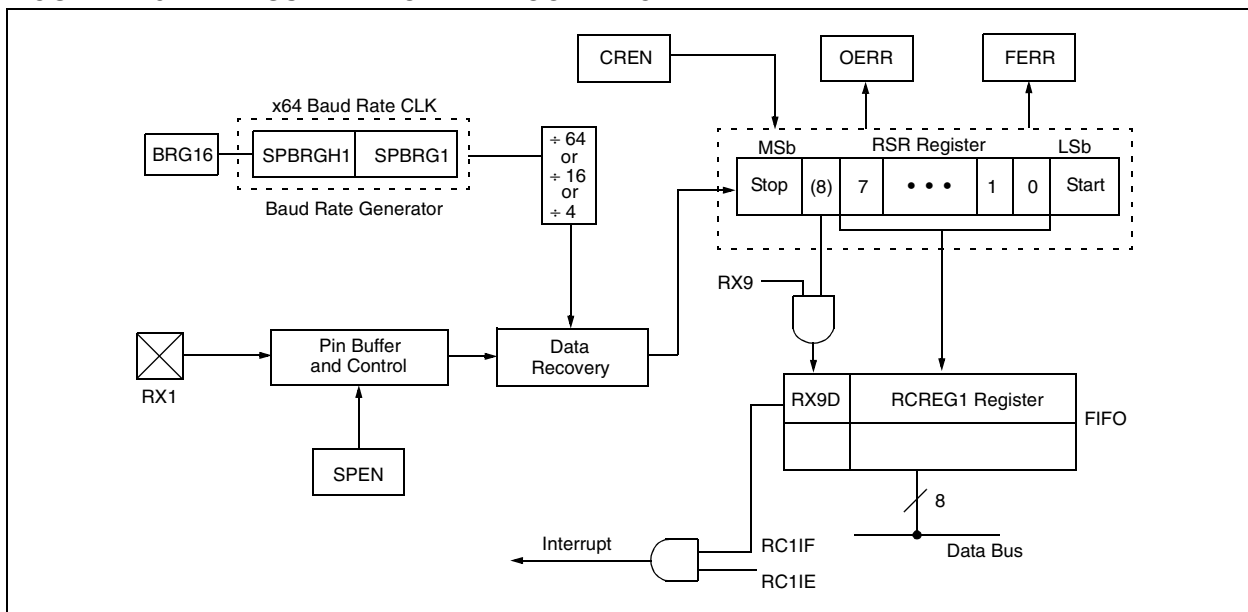

PIC18F85J90 FAMILY

FIGURE 17-7: ASYNCHRONOUS RECEPTION

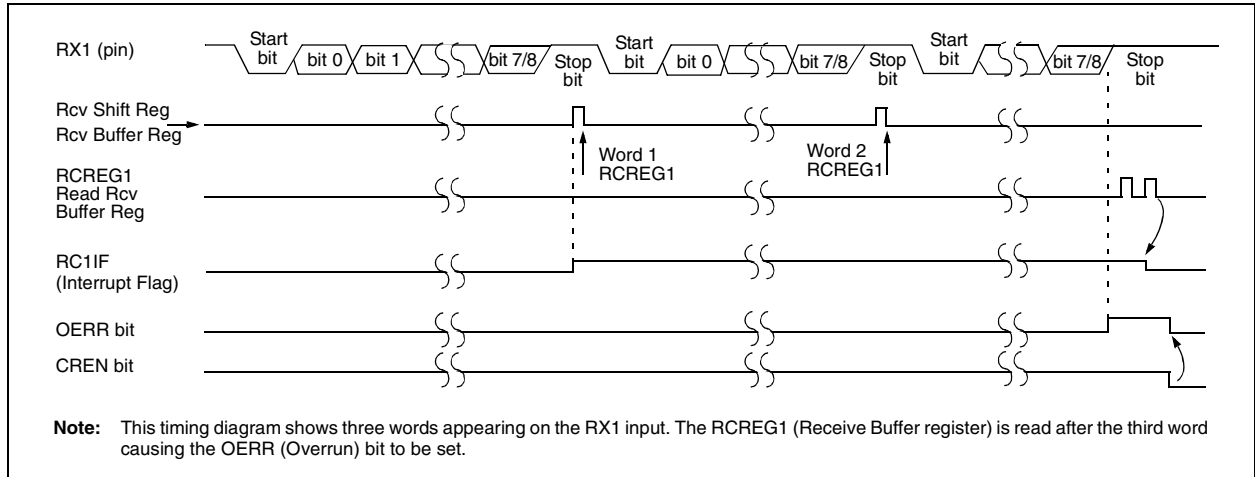

TABLE 17-6: REGISTERS ASSOCIATED WITH ASYNCHRONOUS RECEPTION

Name	Bit 7	Bit 6	Bit 5	Bit 4	Bit 3	Bit 2	Bit 1	Bit 0	Reset Values on Page
INTCON	GIE/GIEH	PEIE/GIEL	TMR0IE	INT0IE	RBIE	TMR0IF	INT0IF	RBIF	51
PIR1	—	ADIF	RC1IF	TX1IF	SSPIF	—	TMR2IF	TMR1IF	54
PIE1	—	ADIE	RC1IE	TX1IE	SSPIE	—	TMR2IE	TMR1IE	54
IPR1	—	ADIP	RC1IP	TX1IP	SSPIP	—	TMR2IP	TMR1IP	54
RCSTA1	SPEN	RX9	SREN	CREN	ADDEN	FERR	OERR	RX9D	53
RCREG1	EUSART Receive Register								53
TXSTA1	CSRC	TX9	TXEN	SYNC	SENDB	BRGH	TRMT	TX9D	53
BAUDCON1	ABDOVF	RCMT	—	SCKP	BRG16	—	WUE	ABDEN	55
SPBRGH1	EUSART Baud Rate Generator Register High Byte								55
SPBRG1	EUSART Baud Rate Generator Register Low Byte								53

Legend: — = unimplemented locations read as '0'. Shaded cells are not used for asynchronous reception.

PIC18F85J90 FAMILY

17.3.4 AUTO-WAKE-UP ON SYNC BREAK CHARACTER

During Sleep mode, all clocks to the EUSART are suspended. Because of this, the Baud Rate Generator is inactive and a proper byte reception cannot be performed. The auto-wake-up feature allows the controller to wake-up, due to activity on the RX1/DT1 line, while the EUSART is operating in Asynchronous mode.

The auto-wake-up feature is enabled by setting the WUE bit (BAUDCON<1>). Once set, the typical receive sequence on RX1/DT1 is disabled and the EUSART remains in an Idle state, monitoring for a wake-up event independent of the CPU mode. A wake-up event consists of a high-to-low transition on the RX1/DT1 line. (This coincides with the start of a Sync Break or a Wake-up Signal character for the LIN protocol.)

Following a wake-up event, the module generates an RC1IF interrupt. The interrupt is generated synchronously to the Q clocks in normal operating modes (Figure 17-8) and asynchronously, if the device is in Sleep mode (Figure 17-9). The interrupt condition is cleared by reading the RCREG1 register.

The WUE bit is automatically cleared once a low-to-high transition is observed on the RX1 line following the wake-up event. At this point, the EUSART module is in Idle mode and returns to normal operation. This signals to the user that the Sync Break event is over.

17.3.4.1 Special Considerations Using Auto-Wake-up

Since auto-wake-up functions by sensing rising edge transitions on RX1/DT1, information with any state changes before the Stop bit may signal a false

end-of-character and cause data or framing errors. Therefore, to work properly, the initial character in the transmission must be all '0's. This can be 00h (8 bytes) for standard RS-232 devices, or 000h (12 bits) for LIN bus.

Oscillator start-up time must also be considered, especially in applications using oscillators with longer start-up intervals (i.e., XT or HS mode). The Sync Break (or Wake-up Signal) character must be of sufficient length and be followed by a sufficient interval to allow enough time for the selected oscillator to start and provide proper initialization of the EUSART.

17.3.4.2 Special Considerations Using the WUE Bit

The timing of WUE and RC1IF events may cause some confusion when it comes to determining the validity of received data. As noted, setting the WUE bit places the EUSART in an Idle mode. The wake-up event causes a receive interrupt by setting the RC1IF bit. The WUE bit is cleared after this when a rising edge is seen on RX1/DT1. The interrupt condition is then cleared by reading the RCREG1 register. Ordinarily, the data in RCREG1 will be dummy data and should be discarded.

The fact that the WUE bit has been cleared (or is still set) and the RC1IF flag is set should not be used as an indicator of the integrity of the data in RCREG1. Users should consider implementing a parallel method in firmware to verify received data integrity.

To assure that no actual data is lost, check the RCMT bit to verify that a receive operation is not in process. If a receive operation is not occurring, the WUE bit may then be set just prior to entering the Sleep mode.

FIGURE 17-8: AUTO-WAKE-UP BIT (WUE) TIMINGS DURING NORMAL OPERATION

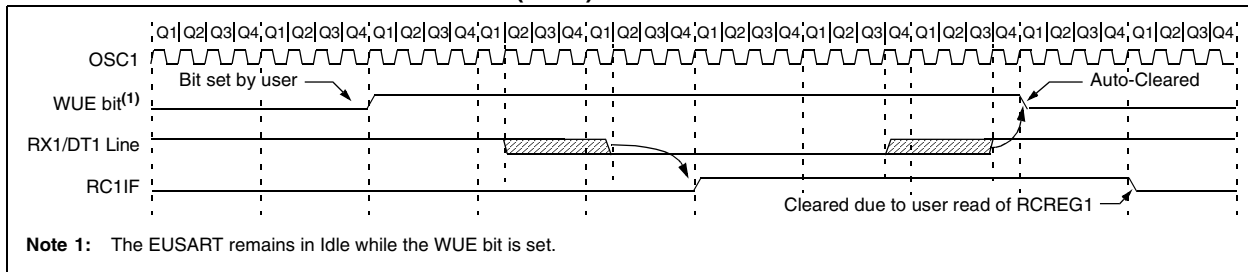
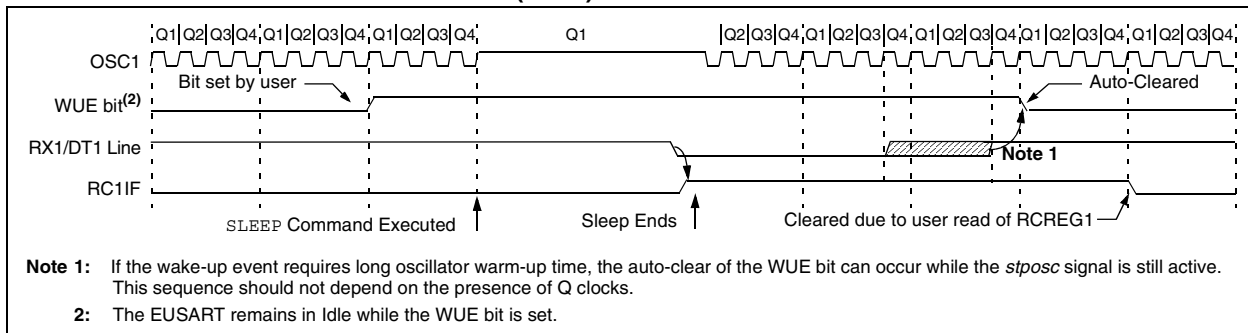

FIGURE 17-9: AUTO-WAKE-UP BIT (WUE) TIMINGS DURING SLEEP



17.3.5 BREAK CHARACTER SEQUENCE

The Enhanced USART module has the capability of sending the special Break character sequences that are required by the LIN bus standard. The Break character transmit consists of a Start bit, followed by twelve '0' bits and a Stop bit. The Frame Break character is sent whenever the SENDB and TXEN bits (TXSTA<3> and TXSTA<5>) are set while the Transmit Shift register is loaded with data. Note that the value of data written to TXREG1 will be ignored and all '0's will be transmitted.

The SENDB bit is automatically reset by hardware after the corresponding Stop bit is sent. This allows the user to preload the transmit FIFO with the next transmit byte following the Break character (typically, the Sync character in the LIN specification).

Note that the data value written to the TXREG1 for the Break character is ignored. The write simply serves the purpose of initiating the proper sequence.

The TRMT bit indicates when the transmit operation is active or Idle, just as it does during normal transmission. See Figure 17-10 for the timing of the Break character sequence.

17.3.5.1 Break and Sync Transmit Sequence

The following sequence will send a message frame header made up of a Break, followed by an Auto-Baud Sync byte. This sequence is typical of a LIN bus master.

1. Configure the EUSART for the desired mode.
2. Set the TXEN and SENDB bits to set up the Break character.
3. Load the TXREG1 with a dummy character to initiate transmission (the value is ignored).
4. Write '55h' to TXREG1 to load the Sync character into the transmit FIFO buffer.
5. After the Break has been sent, the SENDB bit is reset by hardware. The Sync character now transmits in the preconfigured mode.

When the TXREG1 becomes empty, as indicated by the TX1IF, the next data byte can be written to TXREG1.

17.3.6 RECEIVING A BREAK CHARACTER

The Enhanced USART module can receive a Break character in two ways.

The first method forces configuration of the baud rate at a frequency of 9/13 the typical speed. This allows for the Stop bit transition to be at the correct sampling location (13 bits for Break versus Start bit and 8 data bits for typical data).

The second method uses the auto-wake-up feature described in **Section 17.3.4 "Auto-Wake-up On Sync Break Character"**. By enabling this feature, the EUSART will sample the next two transitions on RX1/DT1, cause an RC1IF interrupt and receive the next data byte followed by another interrupt.

Note that following a Break character, the user will typically want to enable the Auto-Baud Rate Detect feature. For both methods, the user can set the ABD bit once the TX1IF interrupt is observed.

FIGURE 17-10: SEND BREAK CHARACTER SEQUENCE

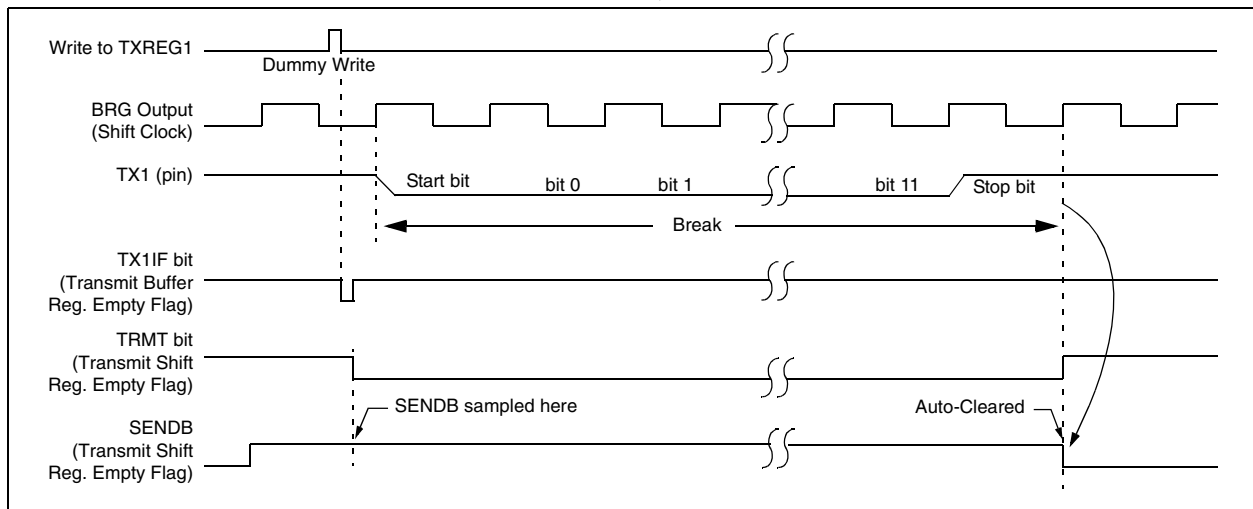

PIC18F85J90 FAMILY

17.4 EUSART Synchronous Master Mode

The Synchronous Master mode is entered by setting the CSRC bit (TXSTA<7>). In this mode, the data is transmitted in a half-duplex manner (i.e., transmission and reception do not occur at the same time). When transmitting data, the reception is inhibited and vice versa. Synchronous mode is entered by setting bit SYNC (TXSTA<4>). In addition, enable bit, SPEN (RCSTA1<7>), is set in order to configure the TX1 and RX1 pins to CK1 (clock) and DT1 (data) lines, respectively.

The Master mode indicates that the processor transmits the master clock on the CK1 line. Clock polarity is selected with the SCKP bit (BAUDCON<4>). Setting SCKP sets the Idle state on CK1 as high, while clearing the bit sets the Idle state as low. This option is provided to support Microwire devices with this module.

17.4.1 EUSART SYNCHRONOUS MASTER TRANSMISSION

The EUSART transmitter block diagram is shown in Figure 17-3. The heart of the transmitter is the Transmit (Serial) Shift register (TSR). The Shift register obtains its data from the Read/Write Transmit Buffer register, TXREG1. The TXREG1 register is loaded with data in software. The TSR register is not loaded until the last bit has been transmitted from the previous load. As soon as the last bit is transmitted, the TSR is loaded with new data from the TXREG1 (if available).

Once the TXREG1 register transfers the data to the TSR register (occurs in one T_{CYCLE}), the TXREG1 is empty and the TX1IF flag bit (PIR1<4>) is set. The interrupt can be enabled or disabled by setting or clearing the interrupt enable bit, TX1IE (PIE1<4>). TX1IF is set regardless of the state of enable bit TX1IE; it cannot be cleared in software. It will reset only when new data is loaded into the TXREG1 register.

While flag bit TX1IF indicates the status of the TXREG1 register, another bit, TRMT (TXSTA<1>), shows the status of the TSR register. TRMT is a read-only bit which is set when the TSR is empty. No interrupt logic is tied to this bit so the user has to poll this bit in order to determine if the TSR register is empty. The TSR is not mapped in data memory so it is not available to the user.

To set up a Synchronous Master Transmission:

1. Initialize the SPBRGH1:SPBRG1 registers for the appropriate baud rate. Set or clear the BRG16 bit, as required, to achieve the desired baud rate.
2. Enable the synchronous master serial port by setting bits SYNC, SPEN and CSRC.
3. If interrupts are desired, set enable bit, TX1IE.
4. If 9-bit transmission is desired, set bit, TX9.
5. Enable the transmission by setting bit, TXEN.
6. If 9-bit transmission is selected, the ninth bit should be loaded in bit TX9D.
7. Start transmission by loading data to the TXREG1 register.
8. If using interrupts, ensure that the GIE and PEIE bits in the INTCON register (INTCON<7:6>) are set.

FIGURE 17-11: SYNCHRONOUS TRANSMISSION

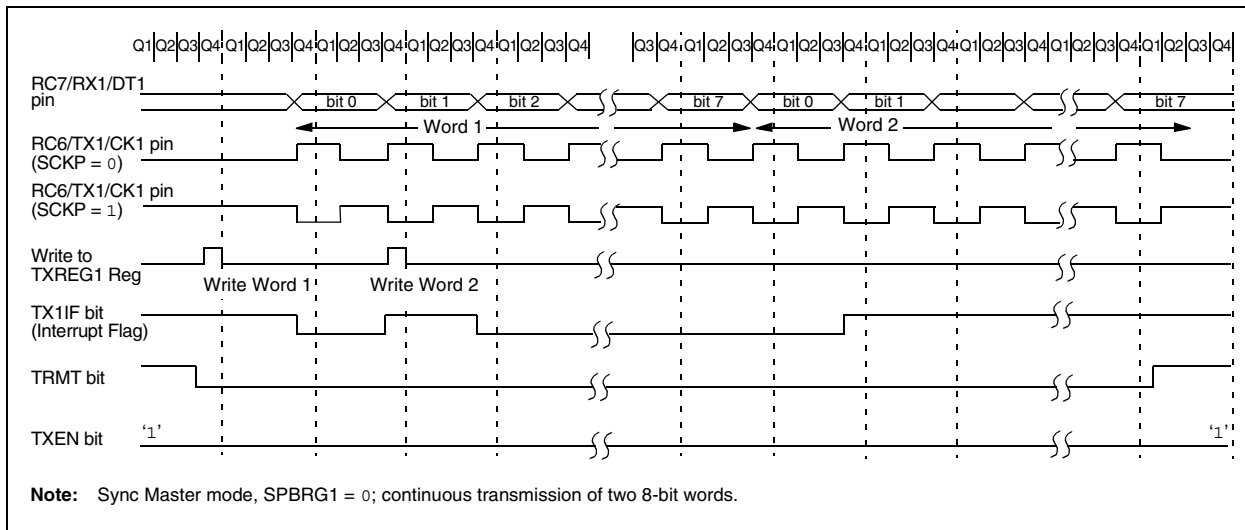

PIC18F85J90 FAMILY

FIGURE 17-12: SYNCHRONOUS TRANSMISSION (THROUGH TXEN)

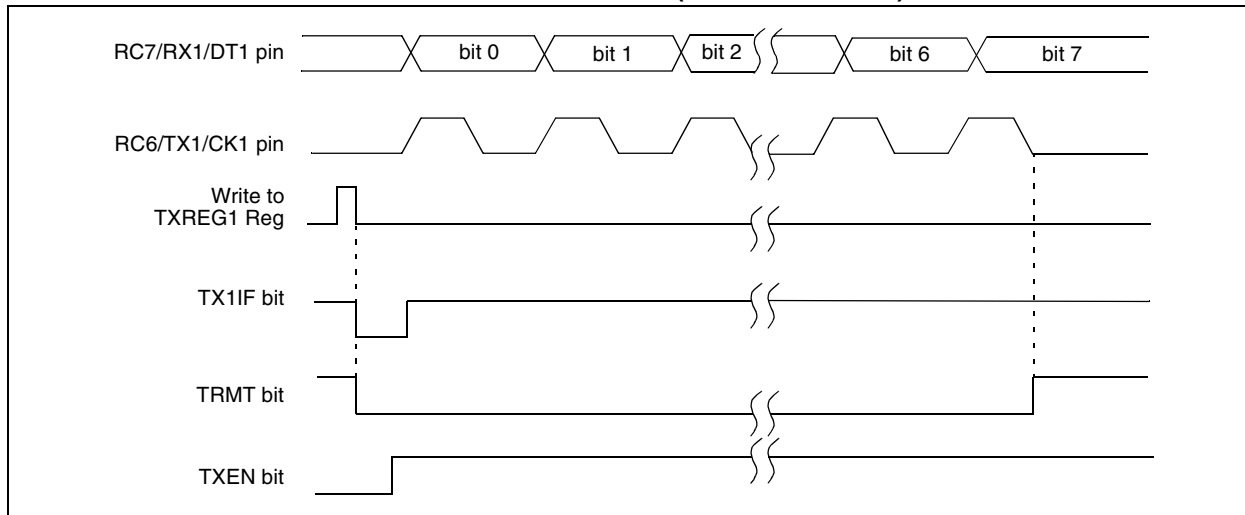

TABLE 17-7: REGISTERS ASSOCIATED WITH SYNCHRONOUS MASTER TRANSMISSION

Name	Bit 7	Bit 6	Bit 5	Bit 4	Bit 3	Bit 2	Bit 1	Bit 0	Reset Values on Page
INTCON	GIE/GIEH	PEIE/GIEL	TMR0IE	INT0IE	RBIE	TMR0IF	INT0IF	RBIF	51
PIR1	—	ADIF	RC1IF	TX1IF	SSPIF	—	TMR2IF	TMR1IF	54
PIE1	—	ADIE	RC1IE	TX1IE	SSPIE	—	TMR2IE	TMR1IE	54
IPR1	—	ADIP	RC1IP	TX1IP	SSPIP	—	TMR2IP	TMR1IP	54
RCSTA1	SPEN	RX9	SREN	CREN	ADDEN	FERR	OERR	RX9D	53
TXREG1	EUSART Transmit Register								53
TXSTA1	CSRC	TX9	TXEN	SYNC	SENDB	BRGH	TRMT	TX9D	53
BAUDCON1	ABDOVF	RCMT	—	SCKP	BRG16	—	WUE	ABDEN	55
SPBRGH1	EUSART Baud Rate Generator Register High Byte								55
SPBRG1	EUSART Baud Rate Generator Register Low Byte								53
LATG	U2OD	U1OD	—	LATG4	LATG3	LATG2	LATG1	LATG0	54

Legend: — = unimplemented, read as '0'. Shaded cells are not used for synchronous master transmission.

PIC18F85J90 FAMILY

17.4.2 EUSART SYNCHRONOUS MASTER RECEPTION

Once Synchronous mode is selected, reception is enabled by setting either the Single Receive Enable bit, SREN (RCSTA1<5>), or the Continuous Receive Enable bit, CREN (RCSTA1<4>). Data is sampled on the RX1 pin on the falling edge of the clock.

If enable bit SREN is set, only a single word is received. If enable bit CREN is set, the reception is continuous until CREN is cleared. If both bits are set, then CREN takes precedence.

To set up a Synchronous Master Reception:

1. Initialize the SPBRGH1:SPBRG1 registers for the appropriate baud rate. Set or clear the BRG16 bit, as required, to achieve the desired baud rate.
2. Enable the synchronous master serial port by setting bits, SYNC, SPEN and CSRC.
3. Ensure bits, CREN and SREN, are clear.
4. If interrupts are desired, set enable bit, RC1IE.
5. If 9-bit reception is desired, set bit, RX9.
6. If a single reception is required, set bit, SREN. For continuous reception, set bit, CREN.
7. Interrupt flag bit, RC1IF, will be set when reception is complete and an interrupt will be generated if the enable bit, RC1IE, was set.
8. Read the RCSTA1 register to get the 9th bit (if enabled) and determine if any error occurred during reception.
9. Read the 8-bit received data by reading the RCREG1 register.
10. If any error occurred, clear the error by clearing bit, CREN.
11. If using interrupts, ensure that the GIE and PEIE bits in the INTCON register (INTCON<7:6>) are set.

FIGURE 17-13: SYNCHRONOUS RECEPTION (MASTER MODE, SREN)

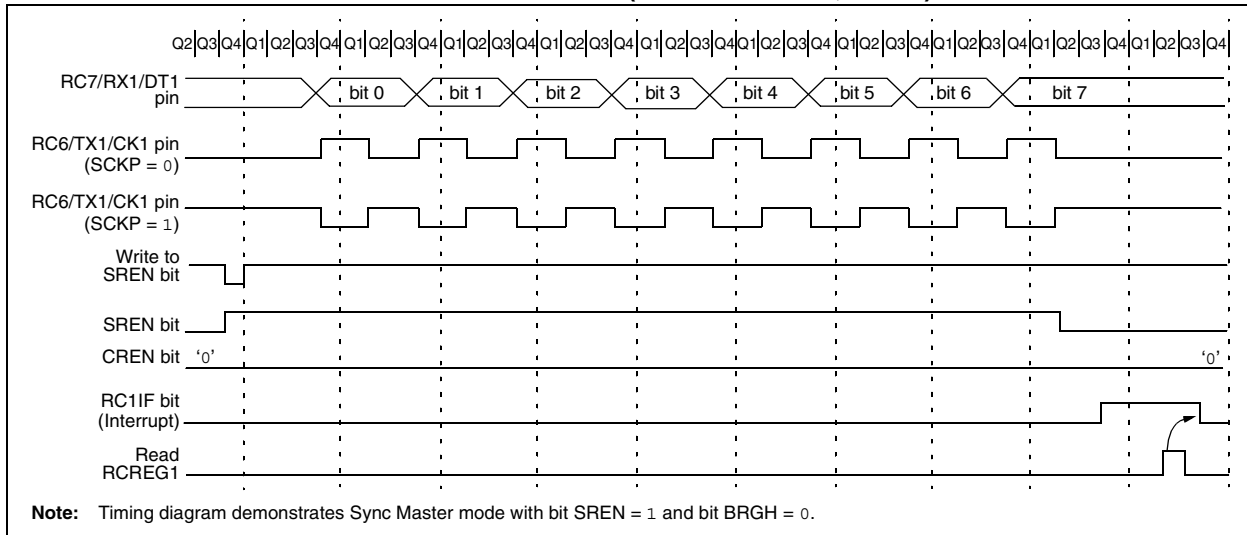

TABLE 17-8: REGISTERS ASSOCIATED WITH SYNCHRONOUS MASTER RECEPTION

Name	Bit 7	Bit 6	Bit 5	Bit 4	Bit 3	Bit 2	Bit 1	Bit 0	Reset Values on Page
INTCON	GIE/GIEH	PEIE/GIEL	TMR0IE	INT0IE	RBIE	TMR0IF	INT0IF	RBF	51
PIR1	—	ADIF	RC1IF	TX1IF	SSPIF	—	TMR2IF	TMR1IF	54
PIE1	—	ADIE	RC1IE	TX1IE	SSPIE	—	TMR2IE	TMR1IE	54
IPR1	—	ADIP	RC1IP	TX1IP	SSPIP	—	TMR2IP	TMR1IP	54
RCSTA1	SPEN	RX9	SREN	CREN	ADDEN	FERR	OERR	RX9D	53
RCREG1	EUSART Receive Register								53
TXSTA1	CSRC	TX9	TXEN	SYNC	SENDB	BRGH	TRMT	TX9D	53
BAUDCON1	ABDOVF	RCMT	—	SCKP	BRG16	—	WUE	ABDEN	55
SPBRGH1	EUSART Baud Rate Generator Register High Byte								55
SPBRG1	EUSART Baud Rate Generator Register Low Byte								53

Legend: — = unimplemented, read as '0'. Shaded cells are not used for synchronous master reception.

17.5 EUSART Synchronous Slave Mode

Synchronous Slave mode is entered by clearing bit CSRC (TXSTA<7>). This mode differs from the Synchronous Master mode in that the shift clock is supplied externally at the CK1 pin (instead of being supplied internally in Master mode). This allows the device to transfer or receive data while in any low-power mode.

17.5.1 EUSART SYNCHRONOUS SLAVE TRANSMIT

The operation of the Synchronous Master and Slave modes are identical except in the case of the Sleep mode.

If two words are written to the TXREG1 and then the SLEEP instruction is executed, the following will occur:

- a) The first word will immediately transfer to the TSR register and transmit.
- b) The second word will remain in the TXREG1 register.
- c) Flag bit, TX1IF, will not be set.
- d) When the first word has been shifted out of TSR, the TXREG1 register will transfer the second word to the TSR and flag bit, TX1IF, will now be set.
- e) If enable bit, TX1IE, is set, the interrupt will wake the chip from Sleep. If the global interrupt is enabled, the program will branch to the interrupt vector.

To set up a Synchronous Slave Transmission:

1. Enable the synchronous slave serial port by setting bits SYNC and SPEN and clearing bit CSRC.
2. Clear bits CREN and SREN.
3. If interrupts are desired, set enable bit, TX1IE.
4. If 9-bit transmission is desired, set bit, TX9.
5. Enable the transmission by setting enable bit, TXEN.
6. If 9-bit transmission is selected, the ninth bit should be loaded in bit TX9D.
7. Start transmission by loading data to the TXREG1 register.
8. If using interrupts, ensure that the GIE and PEIE bits in the INTCON register (INTCON<7:6>) are set.

TABLE 17-9: REGISTERS ASSOCIATED WITH SYNCHRONOUS SLAVE TRANSMISSION

Name	Bit 7	Bit 6	Bit 5	Bit 4	Bit 3	Bit 2	Bit 1	Bit 0	Reset Values on Page
INTCON	GIE/GIEH	PEIE/GIEL	TMR0IE	INT0IE	RBIE	TMR0IF	INT0IF	RBIF	51
PIR1	—	ADIF	RC1IF	TX1IF	SSPIF	—	TMR2IF	TMR1IF	54
PIE1	—	ADIE	RC1IE	TX1IE	SSPIE	—	TMR2IE	TMR1IE	54
IPR1	—	ADIP	RC1IP	TX1IP	SSPIP	—	TMR2IP	TMR1IP	54
RCSTA1	SPEN	RX9	SREN	CREN	ADDEN	FERR	OERR	RX9D	53
TXREG1	EUSART Transmit Register								53
TXSTA1	CSRC	TX9	TXEN	SYNC	SEnDB	BRGH	TRMT	TX9D	53
BAUDCON1	ABDOVF	RCMT	—	SCKP	BRG16	—	WUE	ABDEN	55
SPBRGH1	EUSART Baud Rate Generator Register High Byte								55
SPBRG1	EUSART Baud Rate Generator Register Low Byte								53
LATG	U2OD	U1OD	—	LATG4	LATG3	LATG2	LATG1	LATG0	54

Legend: — = unimplemented, read as '0'. Shaded cells are not used for synchronous slave transmission.

PIC18F85J90 FAMILY

17.5.2 EUSART SYNCHRONOUS SLAVE RECEPTION

The operation of the Synchronous Master and Slave modes is identical except in the case of Sleep or any Idle mode, and bit SREN, which is a “don’t care” in Slave mode.

If receive is enabled by setting the CREN bit prior to entering Sleep or any Idle mode, then a word may be received while in this low-power mode. Once the word is received, the RSR register will transfer the data to the RCREG1 register; if the RC1IE enable bit is set, the interrupt generated will wake the chip from the low-power mode. If the global interrupt is enabled, the program will branch to the interrupt vector.

To set up a Synchronous Slave Reception:

1. Enable the synchronous master serial port by setting bits SYNC and SPEN and clearing bit CSRC.
2. If interrupts are desired, set enable bit, RC1IE.
3. If 9-bit reception is desired, set bit, RX9.
4. To enable reception, set enable bit, CREN.
5. Flag bit, RC1IF, will be set when reception is complete. An interrupt will be generated if enable bit, RC1IE, was set.
6. Read the RCSTA1 register to get the 9th bit (if enabled) and determine if any error occurred during reception.
7. Read the 8-bit received data by reading the RCREG1 register.
8. If any error occurred, clear the error by clearing bit, CREN.
9. If using interrupts, ensure that the GIE and PEIE bits in the INTCON register (INTCON<7:6>) are set.

TABLE 17-10: REGISTERS ASSOCIATED WITH SYNCHRONOUS SLAVE RECEPTION

Name	Bit 7	Bit 6	Bit 5	Bit 4	Bit 3	Bit 2	Bit 1	Bit 0	Reset Values on Page
INTCON	GIE/GIEH	PEIE/GIEL	TMR0IE	INT0IE	RBIE	TMR0IF	INT0IF	RBIF	51
PIR1	—	ADIF	RC1IF	TX1IF	SSPIF	—	TMR2IF	TMR1IF	54
PIE1	—	ADIE	RC1IE	TX1IE	SSPIE	—	TMR2IE	TMR1IE	54
IPR1	—	ADIP	RC1IP	TX1IP	SSPIP	—	TMR2IP	TMR1IP	54
RCSTA1	SPEN	RX9	SREN	CREN	ADDEN	FERR	OERR	RX9D	53
RCREG1	EUSART Receive Register								53
TXSTA1	CSRC	TX9	TXEN	SYNC	SEnDB	BRGH	TRMT	TX9D	53
BAUDCON1	ABDOVF	RCMT	—	SCKP	BRG16	—	WUE	ABDEN	55
SPBRGH1	EUSART Baud Rate Generator Register High Byte								55
SPBRG1	EUSART Baud Rate Generator Register Low Byte								53

Legend: — = unimplemented, read as '0'. Shaded cells are not used for synchronous slave reception.

18.0 ADDRESSABLE UNIVERSAL SYNCHRONOUS ASYNCHRONOUS RECEIVER TRANSMITTER (AUSART)

The Addressable Universal Synchronous Asynchronous Receiver Transmitter (AUSART) module is very similar in function to the Enhanced USART module, discussed in the previous chapter. It is provided as an additional channel for serial communication with external devices, for those situations that do not require auto-baud detection or LIN bus support.

The AUSART can be configured in the following modes:

- Asynchronous (full-duplex)
- Synchronous – Master (half-duplex)
- Synchronous – Slave (half-duplex)

The pins of the AUSART module are multiplexed with the functions of PORTG (RG1/TX2/CK2 and RG2/RX2/DT2/VLCAP1, respectively). In order to configure these pins as an AUSART:

- bit SPEN (RCSTA2<7>) must be set (= 1)
- bit TRISG<2> must be set (= 1)
- bit TRISG<1> must be cleared (= 0) for Asynchronous and Synchronous Master modes
- bit TRISG<1> must be set (= 1) for Synchronous Slave mode

Note: The AUSART control will automatically reconfigure the pin from input to output as needed.

The driver for the TX2 output pin can also be optionally configured as an open-drain output. This feature allows the voltage level on the pin to be pulled to a higher level through an external pull-up resistor, and allows the output to communicate with external circuits without the need for additional level shifters.

The open-drain output option is controlled by the U2OD bit (LATG<7>). Setting the bit configures the pin for open-drain operation.

18.1 Control Registers

The operation of the Addressable USART module is controlled through two registers, TXSTA2 and RXSTA2. These are detailed in Register 18-1 and Register 18-2, respectively.

PIC18F85J90 FAMILY

REGISTER 18-1: TXSTA2: AUSART TRANSMIT STATUS AND CONTROL REGISTER

R/W-0	R/W-0	R/W-0	R/W-0	U-0	R/W-0	R-1	R/W-0
CSRC	TX9	TXEN ⁽¹⁾	SYNC	—	BRGH	TRMT	TX9D
bit 7							bit 0

Legend:

R = Readable bit	W = Writable bit	U = Unimplemented bit, read as '0'
-n = Value at POR	'1' = Bit is set	'0' = Bit is cleared
		x = Bit is unknown

- bit 7 **CSRC:** Clock Source Select bit
Asynchronous mode:
 Don't care.
Synchronous mode:
 1 = Master mode (clock generated internally from BRG)
 0 = Slave mode (clock from external source)
- bit 6 **TX9:** 9-Bit Transmit Enable bit
 1 = Selects 9-bit transmission
 0 = Selects 8-bit transmission
- bit 5 **TXEN:** Transmit Enable bit⁽¹⁾
 1 = Transmit enabled
 0 = Transmit disabled
- bit 4 **SYNC:** AUSART Mode Select bit
 1 = Synchronous mode
 0 = Asynchronous mode
- bit 3 **Unimplemented:** Read as '0'
- bit 2 **BRGH:** High Baud Rate Select bit
Asynchronous mode:
 1 = High speed
 0 = Low speed
Synchronous mode:
 Unused in this mode.
- bit 1 **TRMT:** Transmit Shift Register Status bit
 1 = TSR empty
 0 = TSR full
- bit 0 **TX9D:** 9th bit of Transmit Data
 Can be address/data bit or a parity bit.

Note 1: SREN/CREN overrides TXEN in Sync mode.

PIC18F85J90 FAMILY

REGISTER 18-2: RCSTA2: AUSART RECEIVE STATUS AND CONTROL REGISTER

R/W-0	R/W-0	R/W-0	R/W-0	R/W-0	R-0	R-0	R-x
SPEN	RX9	SREN	CREN	ADDEN	FERR	OERR	RX9D
bit 7							bit 0

Legend:

R = Readable bit	W = Writable bit	U = Unimplemented bit, read as '0'
-n = Value at POR	'1' = Bit is set	'0' = Bit is cleared x = Bit is unknown

- bit 7 **SPEN:** Serial Port Enable bit
 1 = Serial port enabled (configures RX2/DT2 and TX2/CK2 pins as serial port pins)
 0 = Serial port disabled (held in Reset)
- bit 6 **RX9:** 9-Bit Receive Enable bit
 1 = Selects 9-bit reception
 0 = Selects 8-bit reception
- bit 5 **SREN:** Single Receive Enable bit
 Asynchronous mode:
 Don't care.
 Synchronous mode – Master:
 1 = Enables single receive
 0 = Disables single receive
 This bit is cleared after reception is complete.
 Synchronous mode – Slave:
 Don't care.
- bit 4 **CREN:** Continuous Receive Enable bit
 Asynchronous mode:
 1 = Enables receiver
 0 = Disables receiver
 Synchronous mode:
 1 = Enables continuous receive until enable bit CREN is cleared (CREN overrides SREN)
 0 = Disables continuous receive
- bit 3 **ADDEN:** Address Detect Enable bit
 Asynchronous mode 9-bit (RX9 = 1):
 1 = Enables address detection, enables interrupt and loads the receive buffer when RSR<8> is set
 0 = Disables address detection, all bytes are received and ninth bit can be used as parity bit
 Asynchronous mode 9-bit (RX9 = 0):
 Don't care.
- bit 2 **FERR:** Framing Error bit
 1 = Framing error (can be updated by reading RCREG2 register and receiving next valid byte)
 0 = No framing error
- bit 1 **OERR:** Overrun Error bit
 1 = Overrun error (can be cleared by clearing bit CREN)
 0 = No overrun error
- bit 0 **RX9D:** 9th bit of Received Data
 This can be address/data bit or a parity bit and must be calculated by user firmware.

PIC18F85J90 FAMILY

18.2 AUSART Baud Rate Generator (BRG)

The BRG is a dedicated, 8-bit generator that supports both the Asynchronous and Synchronous modes of the AUSART.

The SPBRG2 register controls the period of a free-running timer. In Asynchronous mode, bit BRGH (TXSTA<2>) also controls the baud rate. In Synchronous mode, BRGH is ignored. Table 18-1 shows the formula for computation of the baud rate for different AUSART modes, which only apply in Master mode (internally generated clock).

Given the desired baud rate and FOSC, the nearest integer value for the SPBRG2 register can be calculated using the formulas in Table 18-1. From this, the error in baud rate can be determined. An example calculation is shown in Example 18-1. Typical baud rates and error values for the various Asynchronous modes are shown in Table 18-2. It may be advantageous to use the high baud rate (BRGH = 1) to reduce the baud rate error, or achieve a slow baud rate for a fast oscillator frequency.

Writing a new value to the SPBRG2 register causes the BRG timer to be reset (or cleared). This ensures the BRG does not wait for a timer overflow before outputting the new baud rate.

18.2.1 OPERATION IN POWER-MANAGED MODES

The device clock is used to generate the desired baud rate. When one of the power-managed modes is entered, the new clock source may be operating at a different frequency. This may require an adjustment to the value in the SPBRG2 register.

18.2.2 SAMPLING

The data on the RX2 pin is sampled three times by a majority detect circuit to determine if a high or a low level is present at the RX2 pin.

TABLE 18-1: BAUD RATE FORMULAS

Configuration Bits		BRG/AUSART Mode	Baud Rate Formula
SYNC	BRGH		
0	0	Asynchronous	$F_{OSC}/[64(n+1)]$
0	1	Asynchronous	$F_{OSC}/[16(n+1)]$
1	x	Synchronous	$F_{OSC}/[4(n+1)]$

Legend: x = Don't care, n = Value of SPBRG2 register

EXAMPLE 18-1: CALCULATING BAUD RATE ERROR

For a device with FOSC of 16 MHz, desired baud rate of 9600, Asynchronous mode, BRGH = 0:	
Desired Baud Rate	= $F_{OSC}/(64([SPBRG2] + 1))$
Solving for SPBRG2:	
X	= $((F_{OSC}/\text{Desired Baud Rate})/64) - 1$
	= $((16000000/9600)/64) - 1$
	= $[25.042] = 25$
Calculated Baud Rate	= $16000000/(64(25 + 1))$
	= 9615
Error	= $(\text{Calculated Baud Rate} - \text{Desired Baud Rate})/\text{Desired Baud Rate}$
	= $(9615 - 9600)/9600 = 0.16\%$

TABLE 18-2: REGISTERS ASSOCIATED WITH THE BAUD RATE GENERATOR

Name	Bit 7	Bit 6	Bit 5	Bit 4	Bit 3	Bit 2	Bit 1	Bit 0	Reset Values on Page
TXSTA2	CSRC	TX9	TXEN	SYNC	—	BRGH	TRMT	TX9D	56
RCSTA2	SPEN	RX9	SREN	CREN	ADDEN	FERR	OERR	RX9D	56
SPBRG2	AUSART Baud Rate Generator Register								56

Legend: Shaded cells are not used by the BRG.

PIC18F85J90 FAMILY

TABLE 18-3: BAUD RATES FOR ASYNCHRONOUS MODES

BAUD RATE (K)	BRGH = 0											
	Fosc = 40.000 MHz			Fosc = 20.000 MHz			Fosc = 10.000 MHz			Fosc = 8.000 MHz		
	Actual Rate (K)	% Error	SPBRG value (decimal)	Actual Rate (K)	% Error	SPBRG value (decimal)	Actual Rate (K)	% Error	SPBRG value (decimal)	Actual Rate (K)	% Error	SPBRG value (decimal)
0.3	—	—	—	—	—	—	—	—	—	—	—	—
1.2	—	—	—	1.221	1.73	255	1.202	0.16	129	1.201	-0.16	103
2.4	2.441	1.73	255	2.404	0.16	129	2.404	0.16	64	2.403	-0.16	51
9.6	9.615	0.16	64	9.766	1.73	31	9.766	1.73	15	9.615	-0.16	12
19.2	19.531	1.73	31	19.531	1.73	15	19.531	1.73	7	—	—	—
57.6	56.818	-1.36	10	62.500	8.51	4	52.083	-9.58	2	—	—	—
115.2	125.000	8.51	4	104.167	-9.58	2	78.125	-32.18	1	—	—	—

BAUD RATE (K)	BRGH = 0								
	Fosc = 4.000 MHz			Fosc = 2.000 MHz			Fosc = 1.000 MHz		
	Actual Rate (K)	% Error	SPBRG value (decimal)	Actual Rate (K)	% Error	SPBRG value (decimal)	Actual Rate (K)	% Error	SPBRG value (decimal)
0.3	0.300	0.16	207	0.300	-0.16	103	0.300	-0.16	51
1.2	1.202	0.16	51	1.201	-0.16	25	1.201	-0.16	12
2.4	2.404	0.16	25	2.403	-0.16	12	—	—	—
9.6	8.929	-6.99	6	—	—	—	—	—	—
19.2	20.833	8.51	2	—	—	—	—	—	—
57.6	62.500	8.51	0	—	—	—	—	—	—
115.2	62.500	-45.75	0	—	—	—	—	—	—

BAUD RATE (K)	BRGH = 1											
	Fosc = 40.000 MHz			Fosc = 20.000 MHz			Fosc = 10.000 MHz			Fosc = 8.000 MHz		
	Actual Rate (K)	% Error	SPBRG value (decimal)	Actual Rate (K)	% Error	SPBRG value (decimal)	Actual Rate (K)	% Error	SPBRG value (decimal)	Actual Rate (K)	% Error	SPBRG value (decimal)
0.3	—	—	—	—	—	—	—	—	—	—	—	—
1.2	—	—	—	—	—	—	—	—	—	—	—	—
2.4	—	—	—	—	—	—	2.441	1.73	255	2.403	-0.16	207
9.6	9.766	1.73	255	9.615	0.16	129	9.615	0.16	64	9.615	-0.16	51
19.2	19.231	0.16	129	19.231	0.16	64	19.531	1.73	31	19.230	-0.16	25
57.6	58.140	0.94	42	56.818	-1.36	21	56.818	-1.36	10	55.555	3.55	8
115.2	113.636	-1.36	21	113.636	-1.36	10	125.000	8.51	4	—	—	—

BAUD RATE (K)	BRGH = 1								
	Fosc = 4.000 MHz			Fosc = 2.000 MHz			Fosc = 1.000 MHz		
	Actual Rate (K)	% Error	SPBRG value (decimal)	Actual Rate (K)	% Error	SPBRG value (decimal)	Actual Rate (K)	% Error	SPBRG value (decimal)
0.3	—	—	—	—	—	—	0.300	-0.16	207
1.2	1.202	0.16	207	1.201	-0.16	103	1.201	-0.16	51
2.4	2.404	0.16	103	2.403	-0.16	51	2.403	-0.16	25
9.6	9.615	0.16	25	9.615	-0.16	12	—	—	—
19.2	19.231	0.16	12	—	—	—	—	—	—
57.6	62.500	8.51	3	—	—	—	—	—	—
115.2	125.000	8.51	1	—	—	—	—	—	—

PIC18F85J90 FAMILY

18.3 AUSART Asynchronous Mode

The Asynchronous mode of operation is selected by clearing the SYNC bit (TXSTA2<4>). In this mode, the AUSART uses standard Non-Return-to-Zero (NRZ) format (one Start bit, eight or nine data bits and one Stop bit). The most common data format is 8 bits. An on-chip, dedicated, 8-bit Baud Rate Generator can be used to derive standard baud rate frequencies from the oscillator.

The AUSART transmits and receives the LSb first. The AUSART's transmitter and receiver are functionally independent but use the same data format and baud rate. The Baud Rate Generator produces a clock, either x16 or x64 of the bit shift rate, depending on the BRGH bit (TXSTA2<2>). Parity is not supported by the hardware but can be implemented in software and stored as the 9th data bit.

When operating in Asynchronous mode, the AUSART module consists of the following important elements:

- Baud Rate Generator
- Sampling Circuit
- Asynchronous Transmitter
- Asynchronous Receiver

18.3.1 AUSART ASYNCHRONOUS TRANSMITTER

The AUSART transmitter block diagram is shown in Figure 18-1. The heart of the transmitter is the Transmit (Serial) Shift register (TSR). The Shift register obtains its data from the Read/Write Transmit Buffer register, TXREG2. The TXREG2 register is loaded with data in software. The TSR register is not loaded until the Stop bit has been transmitted from the previous load. As soon as the Stop bit is transmitted, the TSR is loaded with new data from the TXREG2 register (if available).

Once the TXREG2 register transfers the data to the TSR register (occurs in one Tcy), the TXREG2 register is empty and the TX2IF flag bit (PIR3<4>) is set. This interrupt can be enabled or disabled by setting or clearing the interrupt enable bit, TX2IE (PIE3<4>). TX2IF will be set regardless of the state of TX2IE; it cannot be cleared in software. TX2IF is also not cleared immediately upon loading TXREG2, but becomes valid in the second instruction cycle following the load instruction. Polling TX2IF immediately following a load of TXREG2 will return invalid results.

While TX2IF indicates the status of the TXREG2 register, another bit, TRMT (TXSTA2<1>), shows the status of the TSR register. TRMT is a read-only bit which is set when the TSR register is empty. No interrupt logic is tied to this bit so the user has to poll this bit in order to determine if the TSR register is empty.

Note 1: The TSR register is not mapped in data memory so it is not available to the user.

2: Flag bit, TX2IF, is set when enable bit, TXEN, is set.

To set up an Asynchronous Transmission:

1. Initialize the SPBRG2 register for the appropriate baud rate. Set or clear the BRGH bit, as required, to achieve the desired baud rate.
2. Enable the asynchronous serial port by clearing bit SYNC and setting bit SPEN.
3. If interrupts are desired, set enable bit, TX2IE.
4. If 9-bit transmission is desired, set transmit bit, TX9. Can be used as address/data bit.
5. Enable the transmission by setting bit, TXEN, which will also set bit, TX2IF.
6. If 9-bit transmission is selected, the ninth bit should be loaded in bit, TX9D.
7. Load data to the TXREG2 register (starts transmission).
8. If using interrupts, ensure that the GIE and PEIE bits in the INTCON register (INTCON<7:6>) are set.

FIGURE 18-1: AUSART TRANSMIT BLOCK DIAGRAM

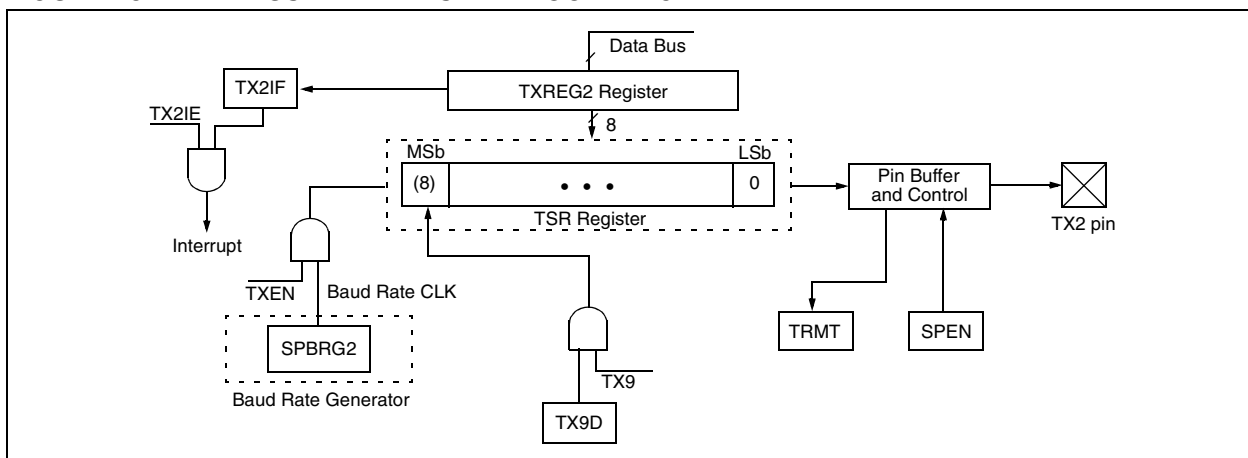

PIC18F85J90 FAMILY

FIGURE 18-2: ASYNCHRONOUS TRANSMISSION

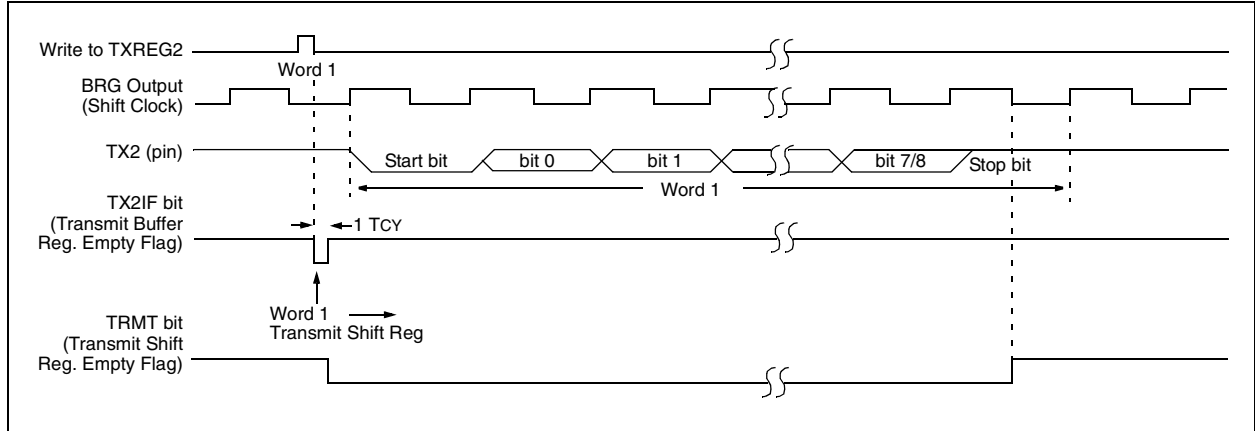

FIGURE 18-3: ASYNCHRONOUS TRANSMISSION (BACK TO BACK)

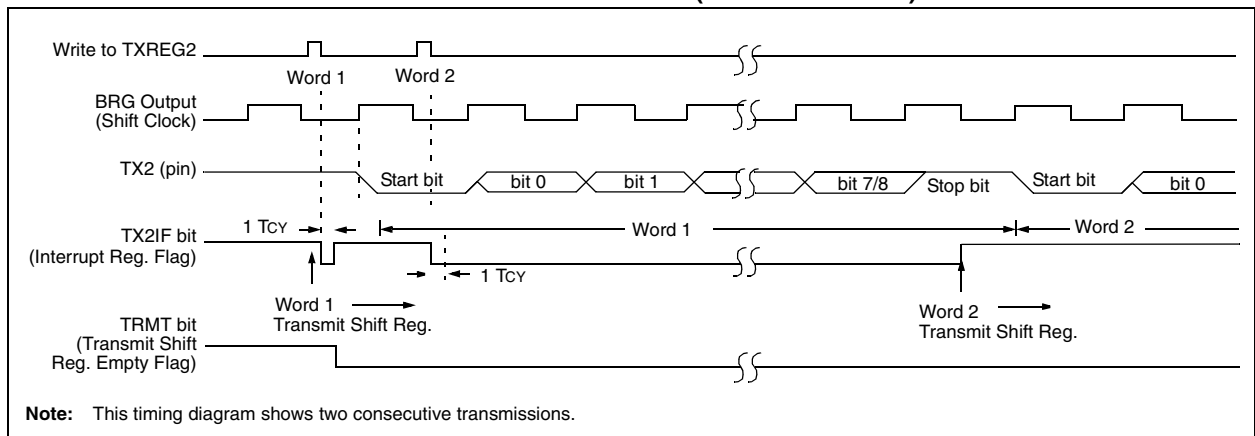

TABLE 18-4: REGISTERS ASSOCIATED WITH ASYNCHRONOUS TRANSMISSION

Name	Bit 7	Bit 6	Bit 5	Bit 4	Bit 3	Bit 2	Bit 1	Bit 0	Reset Values on Page
INTCON	GIE/GIEH	PEIE/GIEL	TMR0IE	INT0IE	RBIE	TMR0IF	INT0IF	RBIF	51
PIR3	—	LCDIF	RC2IF	TX2IF	—	CCP2IF	CCP1IF	—	54
PIE3	—	LCDIE	RC2IE	TX2IE	—	CCP2IE	CCP1IE	—	54
IPR3	—	LCDIP	RC2IP	TX2IP	—	CCP2IP	CCP1IP	—	54
RCSTA2	SPEN	RX9	SREN	CREN	ADDEN	FERR	OERR	RX9D	56
TXREG2	AUSART Transmit Register								56
TXSTA2	CSRC	TX9	TXEN	SYNC	—	BRGH	TRMT	TX9D	56
SPBRG2	AUSART Baud Rate Generator Register								56
LATG	U2OD	U1OD	—	LATG4	LATG3	LATG2	LATG1	LATG0	54

Legend: — = unimplemented locations read as '0'. Shaded cells are not used for asynchronous transmission.

PIC18F85J90 FAMILY

18.3.2 AUSART ASYNCHRONOUS RECEIVER

The receiver block diagram is shown in Figure 18-4. The data is received on the RX2 pin and drives the data recovery block. The data recovery block is actually a high-speed shifter operating at x16 times the baud rate, whereas the main receive serial shifter operates at the bit rate or at FOSC. This mode would typically be used in RS-232 systems.

To set up an Asynchronous Reception:

1. Initialize the SPBRG2 register for the appropriate baud rate. Set or clear the BRGH bit, as required, to achieve the desired baud rate.
2. Enable the asynchronous serial port by clearing bit, SYNC, and setting bit, SPEN.
3. If interrupts are desired, set enable bit, RC2IE.
4. If 9-bit reception is desired, set bit, RX9.
5. Enable the reception by setting bit, CREN.
6. Flag bit, RC2IF, will be set when reception is complete and an interrupt will be generated if enable bit, RC2IE, was set.
7. Read the RCSTA2 register to get the 9th bit (if enabled) and determine if any error occurred during reception.
8. Read the 8-bit received data by reading the RCREG2 register.
9. If any error occurred, clear the error by clearing enable bit, CREN.
10. If using interrupts, ensure that the GIE and PEIE bits in the INTCON register (INTCON<7:6>) are set.

18.3.3 SETTING UP 9-BIT MODE WITH ADDRESS DETECT

This mode would typically be used in RS-485 systems. To set up an Asynchronous Reception with Address Detect Enable:

1. Initialize the SPBRG2 register for the appropriate baud rate. Set or clear the BRGH and BRG16 bits, as required, to achieve the desired baud rate.
2. Enable the asynchronous serial port by clearing the SYNC bit and setting the SPEN bit.
3. If interrupts are required, set the RCEN bit and select the desired priority level with the RC2IP bit.
4. Set the RX9 bit to enable 9-bit reception.
5. Set the ADDEN bit to enable address detect.
6. Enable reception by setting the CREN bit.
7. The RC2IF bit will be set when reception is complete. The interrupt will be Acknowledged if the RC2IE and GIE bits are set.
8. Read the RCSTA2 register to determine if any error occurred during reception, as well as read bit 9 of data (if applicable).
9. Read RCREG2 to determine if the device is being addressed.
10. If any error occurred, clear the CREN bit.
11. If the device has been addressed, clear the ADDEN bit to allow all received data into the receive buffer and interrupt the CPU.

FIGURE 18-4: AUSART RECEIVE BLOCK DIAGRAM

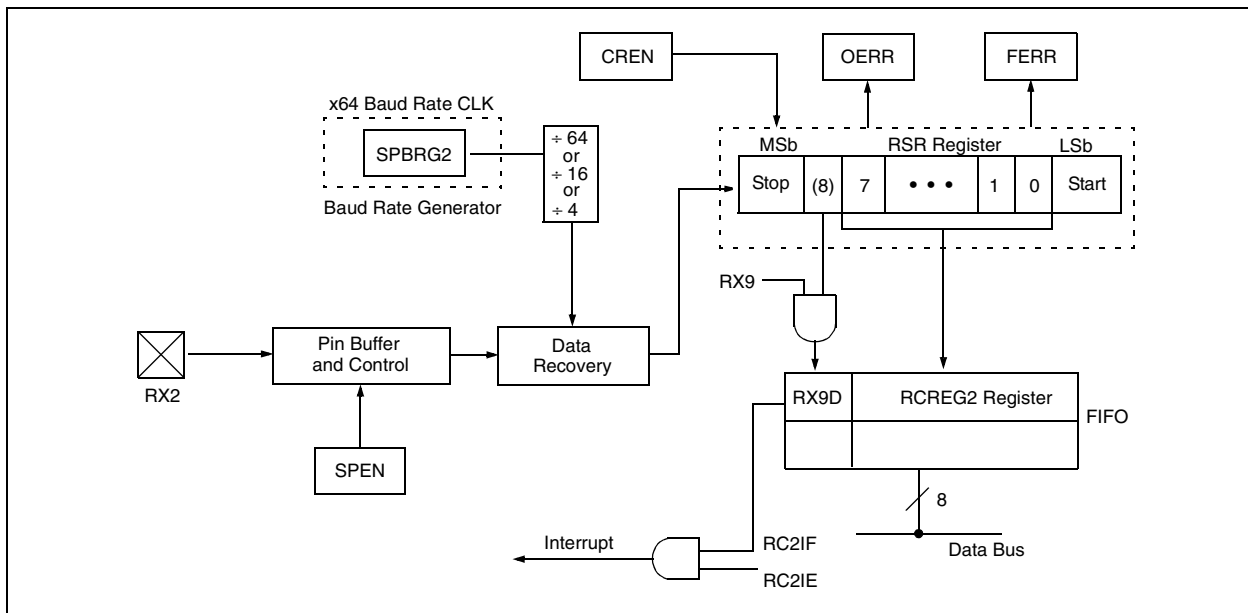

PIC18F85J90 FAMILY

FIGURE 18-5: ASYNCHRONOUS RECEPTION

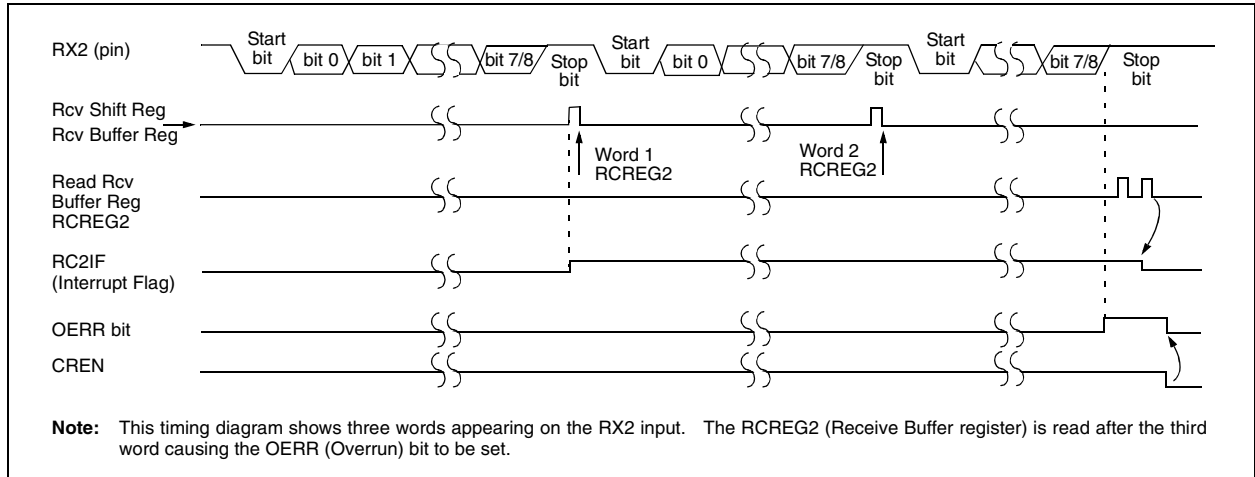

TABLE 18-5: REGISTERS ASSOCIATED WITH ASYNCHRONOUS RECEPTION

Name	Bit 7	Bit 6	Bit 5	Bit 4	Bit 3	Bit 2	Bit 1	Bit 0	Reset Values on Page
INTCON	GIE/GIEH	PEIE/GIEL	TMR0IE	INT0IE	RBIE	TMR0IF	INT0IF	RBIF	51
PIR3	—	LCDIF	RC2IF	TX2IF	—	CCP2IF	CCP1IF	—	54
PIE3	—	LCDIE	RC2IE	TX2IE	—	CCP2IE	CCP1IE	—	54
IPR3	—	LCDIP	RC2IP	TX2IP	—	CCP2IP	CCP1IP	—	54
RCSTA2	SPEN	RX9	SREN	CREN	ADDEN	FERR	OERR	RX9D	56
RCREG2	AUSART Receive Register								56
TXSTA2	CSRC	TX9	TXEN	SYNC	—	BRGH	TRMT	TX9D	56
SPBRG2	AUSART Baud Rate Generator Register								56

Legend: — = unimplemented locations read as '0'. Shaded cells are not used for asynchronous reception.

PIC18F85J90 FAMILY

18.4 AUSART Synchronous Master Mode

The Synchronous Master mode is entered by setting the CSRC bit (TXSTA2<7>). In this mode, the data is transmitted in a half-duplex manner (i.e., transmission and reception do not occur at the same time). When transmitting data, the reception is inhibited and vice versa. Synchronous mode is entered by setting bit, SYNC (TXSTA2<4>). In addition, enable bit, SPEN (RCSTA2<7>), is set in order to configure the TX2 and RX2 pins to CK2 (clock) and DT2 (data) lines, respectively.

The Master mode indicates that the processor transmits the master clock on the CK2 line.

18.4.1 AUSART SYNCHRONOUS MASTER TRANSMISSION

The AUSART transmitter block diagram is shown in Figure 18-1. The heart of the transmitter is the Transmit (Serial) Shift register (TSR). The Shift register obtains its data from the Read/Write Transmit Buffer register, TXREG2. The TXREG2 register is loaded with data in software. The TSR register is not loaded until the last bit has been transmitted from the previous load. As soon as the last bit is transmitted, the TSR is loaded with new data from the TXREG2 (if available).

Once the TXREG2 register transfers the data to the TSR register (occurs in one T_{CYCLE}), the TXREG2 is empty and the TX2IF flag bit (PIR3<4>) is set. The interrupt can be enabled or disabled by setting or clearing the interrupt enable bit, TX2IE (PIE3<4>). TX2IF is set regardless of the state of enable bit, TX2IE; it cannot be cleared in software. It will reset only when new data is loaded into the TXREG2 register.

While flag bit, TX2IF, indicates the status of the TXREG2 register, another bit, TRMT (TXSTA2<1>), shows the status of the TSR register. TRMT is a read-only bit which is set when the TSR is empty. No interrupt logic is tied to this bit so the user has to poll this bit in order to determine if the TSR register is empty. The TSR is not mapped in data memory so it is not available to the user.

To set up a Synchronous Master Transmission:

1. Initialize the SPBRG2 register for the appropriate baud rate.
2. Enable the synchronous master serial port by setting bits, SYNC, SPEN and CSRC.
3. If interrupts are desired, set enable bit, TX2IE.
4. If 9-bit transmission is desired, set bit, TX9.
5. Enable the transmission by setting bit, TXEN.
6. If 9-bit transmission is selected, the ninth bit should be loaded in bit TX9D.
7. Start transmission by loading data to the TXREG2 register.
8. If using interrupts, ensure that the GIE and PEIE bits in the INTCON register (INTCON<7:6>) are set.

FIGURE 18-6: SYNCHRONOUS TRANSMISSION

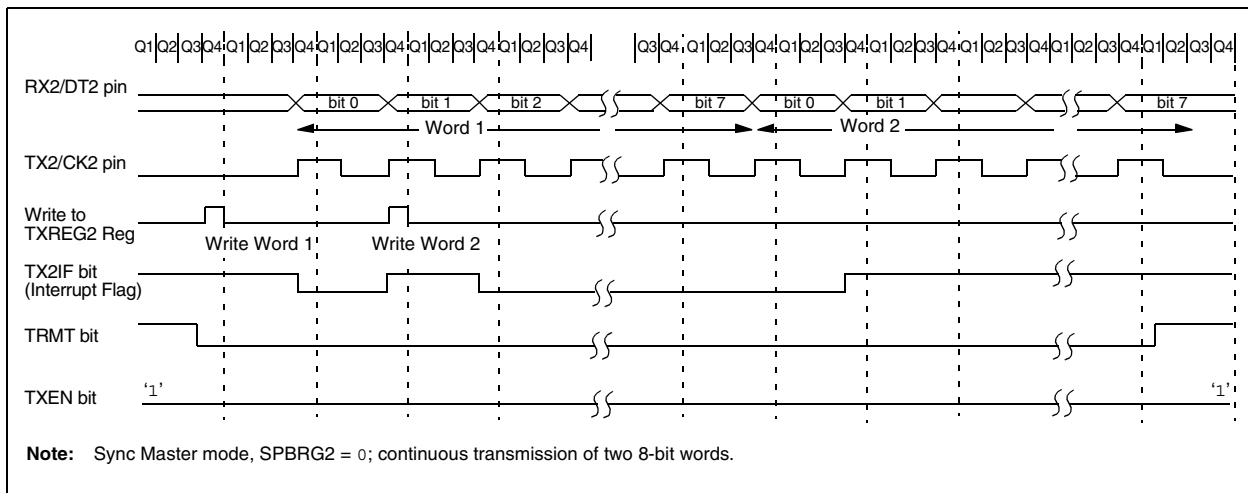

PIC18F85J90 FAMILY

FIGURE 18-7: SYNCHRONOUS TRANSMISSION (THROUGH TXEN)

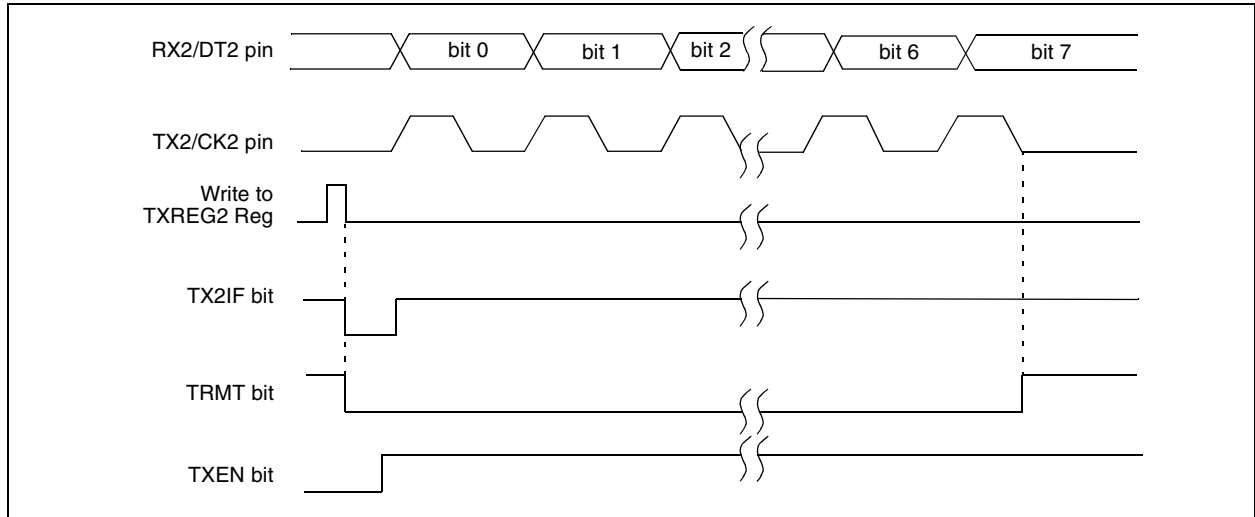

TABLE 18-6: REGISTERS ASSOCIATED WITH SYNCHRONOUS MASTER TRANSMISSION

Name	Bit 7	Bit 6	Bit 5	Bit 4	Bit 3	Bit 2	Bit 1	Bit 0	Reset Values on Page
INTCON	GIE/GIEH	PEIE/GIEL	TMR0IE	INT0IE	RBIE	TMR0IF	INT0IF	RBIF	51
PIR3	—	LCDIF	RC2IF	TX2IF	—	CCP2IF	CCP1IF	—	54
PIE3	—	LCDIE	RC2IE	TX2IE	—	CCP2IE	CCP1IE	—	54
IPR3	—	LCDIP	RC2IP	TX2IP	—	CCP2IP	CCP1IP	—	54
RCSTA2	SPEN	RX9	SREN	CREN	ADDEN	FERR	OERR	RX9D	56
TXREG2	AUSART Transmit Register								56
TXSTA2	CSRC	TX9	TXEN	SYNC	—	BRGH	TRMT	TX9D	56
SPBRG2	AUSART Baud Rate Generator Register								56
LATG	U2OD	U1OD	—	LATG4	LATG3	LATG2	LATG1	LATG0	54

Legend: — = unimplemented, read as '0'. Shaded cells are not used for synchronous master transmission.

PIC18F85J90 FAMILY

18.4.2 AUSART SYNCHRONOUS MASTER RECEPTION

Once Synchronous mode is selected, reception is enabled by setting either the Single Receive Enable bit, SREN (RCSTA2<5>), or the Continuous Receive Enable bit, CREN (RCSTA2<4>). Data is sampled on the RX2 pin on the falling edge of the clock.

If enable bit SREN is set, only a single word is received. If enable bit CREN is set, the reception is continuous until CREN is cleared. If both bits are set, then CREN takes precedence.

To set up a Synchronous Master Reception:

1. Initialize the SPBRG2 register for the appropriate baud rate.
2. Enable the synchronous master serial port by setting bits SYNC, SPEN and CSRC.
3. Ensure bits CREN and SREN are clear.
4. If interrupts are desired, set enable bit, RC2IE.
5. If 9-bit reception is desired, set bit, RX9.
6. If a single reception is required, set bit, SREN. For continuous reception, set bit, CREN.
7. Interrupt flag bit, RC2IF, will be set when reception is complete and an interrupt will be generated if the enable bit, RC2IE, was set.
8. Read the RCSTA2 register to get the 9th bit (if enabled) and determine if any error occurred during reception.
9. Read the 8-bit received data by reading the RCREG2 register.
10. If any error occurred, clear the error by clearing bit, CREN.
11. If using interrupts, ensure that the GIE and PEIE bits in the INTCON register (INTCON<7:6>) are set.

FIGURE 18-8: SYNCHRONOUS RECEPTION (MASTER MODE, SREN)

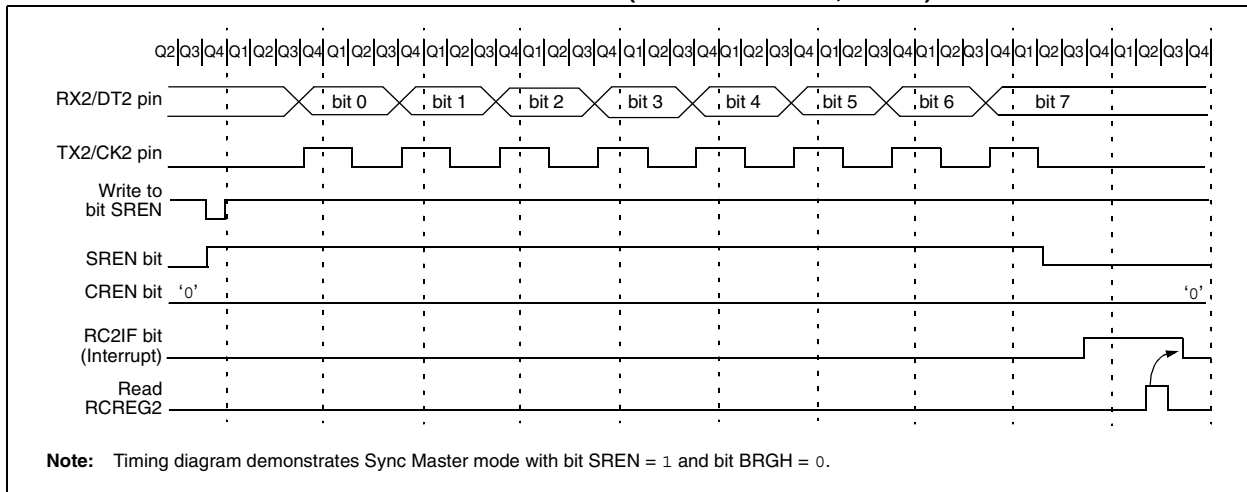

TABLE 18-7: REGISTERS ASSOCIATED WITH SYNCHRONOUS MASTER RECEPTION

Name	Bit 7	Bit 6	Bit 5	Bit 4	Bit 3	Bit 2	Bit 1	Bit 0	Reset Values on Page
INTCON	GIE/GIEH	PEIE/GIEL	TMR0IE	INT0IE	RBIE	TMR0IF	INT0IF	RBIF	51
PIR3	—	LCDIF	RC2IF	TX2IF	—	CCP2IF	CCP1IF	—	54
PIE3	—	LCDIE	RC2IE	TX2IE	—	CCP2IE	CCP1IE	—	54
IPR3	—	LCDIP	RC2IP	TX2IP	—	CCP2IP	CCP1IP	—	54
RCSTA2	SPEN	RX9	SREN	CREN	ADDEN	FERR	OERR	RX9D	56
RCREG2	AUSART Receive Register								56
TXSTA2	CSRC	TX9	TXEN	SYNC	—	BRGH	TRMT	TX9D	56
SPBRG2	AUSART Baud Rate Generator Register								56

Legend: — = unimplemented, read as '0'. Shaded cells are not used for synchronous master reception.

18.5 AUSART Synchronous Slave Mode

Synchronous Slave mode is entered by clearing bit, CSRC (TXSTA2<7>). This mode differs from the Synchronous Master mode in that the shift clock is supplied externally at the CK2 pin (instead of being supplied internally in Master mode). This allows the device to transfer or receive data while in any low-power mode.

18.5.1 AUSART SYNCHRONOUS SLAVE TRANSMIT

The operation of the Synchronous Master and Slave modes are identical except in the case of the Sleep mode.

If two words are written to the TXREG2 and then the SLEEP instruction is executed, the following will occur:

- a) The first word will immediately transfer to the TSR register and transmit.
- b) The second word will remain in TXREG2 register.
- c) Flag bit, TX2IF, will not be set.
- d) When the first word has been shifted out of TSR, the TXREG2 register will transfer the second word to the TSR and flag bit, TX2IF, will now be set.
- e) If enable bit, TX2IE, is set, the interrupt will wake the chip from Sleep. If the global interrupt is enabled, the program will branch to the interrupt vector.

To set up a Synchronous Slave Transmission:

1. Enable the synchronous slave serial port by setting bits, SYNC and SPEN, and clearing bit, CSRC.
2. Clear bits, CREN and SREN.
3. If interrupts are desired, set enable bit, TX2IE.
4. If 9-bit transmission is desired, set bit, TX9.
5. Enable the transmission by setting enable bit, TXEN.
6. If 9-bit transmission is selected, the ninth bit should be loaded in bit TX9D.
7. Start transmission by loading data to the TXREG2 register.
8. If using interrupts, ensure that the GIE and PEIE bits in the INTCON register (INTCON<7:6>) are set.

TABLE 18-8: REGISTERS ASSOCIATED WITH SYNCHRONOUS SLAVE TRANSMISSION

Name	Bit 7	Bit 6	Bit 5	Bit 4	Bit 3	Bit 2	Bit 1	Bit 0	Reset Values on Page
INTCON	GIE/GIEH	PEIE/GIEL	TMR0IE	INT0IE	RBIE	TMR0IF	INT0IF	RBIF	51
PIR3	—	LCDIF	RC2IF	TX2IF	—	CCP2IF	CCP1IF	—	54
PIE3	—	LCDIE	RC2IE	TX2IE	—	CCP2IE	CCP1IE	—	54
IPR3	—	LCDIP	RC2IP	TX2IP	—	CCP2IP	CCP1IP	—	54
RCSTA2	SPEN	RX9	SREN	CREN	ADDEN	FERR	OERR	RX9D	56
TXREG2	AUSART Transmit Register								56
TXSTA2	CSRC	TX9	TXEN	SYNC	—	BRGH	TRMT	TX9D	56
SPBRG2	AUSART Baud Rate Generator Register								56
LATG	U2OD	U1OD	—	LATG4	LATG3	LATG2	LATG1	LATG0	54

Legend: — = unimplemented, read as '0'. Shaded cells are not used for synchronous slave transmission.

PIC18F85J90 FAMILY

18.5.2 AUSART SYNCHRONOUS SLAVE RECEPTION

The operation of the Synchronous Master and Slave modes is identical except in the case of Sleep or any Idle mode, and bit SREN, which is a “don’t care” in Slave mode.

If receive is enabled by setting the CREN bit prior to entering Sleep, or any Idle mode, then a word may be received while in this low-power mode. Once the word is received, the RSR register will transfer the data to the RCREG2 register; if the RC2IE enable bit is set, the interrupt generated will wake the chip from low-power mode. If the global interrupt is enabled, the program will branch to the interrupt vector.

To set up a Synchronous Slave Reception:

1. Enable the synchronous master serial port by setting bits, SYNC and SPEN, and clearing bit, CSRC.
2. If interrupts are desired, set enable bit, RC2IE.
3. If 9-bit reception is desired, set bit, RX9.
4. To enable reception, set enable bit, CREN.
5. Flag bit, RC2IF, will be set when reception is complete. An interrupt will be generated if enable bit, RC2IE, was set.
6. Read the RCSTA2 register to get the 9th bit (if enabled) and determine if any error occurred during reception.
7. Read the 8-bit received data by reading the RCREG2 register.
8. If any error occurred, clear the error by clearing bit, CREN.
9. If using interrupts, ensure that the GIE and PEIE bits in the INTCON register (INTCON<7:6>) are set.

TABLE 18-9: REGISTERS ASSOCIATED WITH SYNCHRONOUS SLAVE RECEPTION

Name	Bit 7	Bit 6	Bit 5	Bit 4	Bit 3	Bit 2	Bit 1	Bit 0	Reset Values on Page
INTCON	GIE/GIEH	PEIE/GIEL	TMR0IE	INT0IE	RBIE	TMR0IF	INT0IF	RBIF	51
PIR3	—	LCDIF	RC2IF	TX2IF	—	CCP2IF	CCP1IF	—	54
PIE3	—	LCDIE	RC2IE	TX2IE	—	CCP2IE	CCP1IE	—	54
IPR3	—	LCDIP	RC2IP	TX2IP	—	CCP2IP	CCP1IP	—	54
RCSTA2	SPEN	RX9	SREN	CREN	ADDEN	FERR	OERR	RX9D	56
RCREG2	AUSART Receive Register								56
TXSTA2	CSRC	TX9	TXEN	SYNC	—	BRGH	TRMT	TX9D	56
SPBRG2	AUSART Baud Rate Generator Register								56

Legend: — = unimplemented, read as ‘0’. Shaded cells are not used for synchronous slave reception.

PIC18F85J90 FAMILY

19.0 10-BIT ANALOG-TO-DIGITAL CONVERTER (A/D) MODULE

The Analog-to-Digital (A/D) converter module has 12 inputs for all PIC18F85J90 family devices. This module allows conversion of an analog input signal to a corresponding 10-bit digital number.

The module has five registers:

- A/D Result High Register (ADRESH)
- A/D Result Low Register (ADRESL)
- A/D Control Register 0 (ADCON0)
- A/D Control Register 1 (ADCON1)
- A/D Control Register 2 (ADCON2)

The ADCON0 register, shown in Register 19-1, controls the operation of the A/D module. The ADCON1 register, shown in Register 19-2, configures the functions of the port pins. The ADCON2 register, shown in Register 19-3, configures the A/D clock source, programmed acquisition time and justification.

REGISTER 19-1: ADCON0: A/D CONTROL REGISTER 0

R/W-0	U-0	R/W-0	R/W-0	R/W-0	R/W-0	R/W-0	R/W-0
ADCAL	—	CHS3	CHS2	CHS1	CHS0	GO/DONE	ADON
bit 7							bit 0

Legend:

R = Readable bit	W = Writable bit	U = Unimplemented bit, read as '0'
-n = Value at POR	'1' = Bit is set	'0' = Bit is cleared
		x = Bit is unknown

- bit 7 **ADCAL:** A/D Calibration bit
 1 = Calibration is performed on next A/D conversion
 0 = Normal A/D converter operation (no calibration is performed)
- bit 6 **Unimplemented:** Read as '0'
- bit 5-2 **CHS3:CHS0:** Analog Channel Select bits
 0000 = Channel 00 (AN0)
 0001 = Channel 01 (AN1)
 0010 = Channel 02 (AN2)
 0011 = Channel 03 (AN3)
 0100 = Channel 04 (AN4)
 0101 = Channel 05 (AN5)
 0110 = Channel 06 (AN6)
 0111 = Channel 07 (AN7)
 1000 = Channel 08 (AN8)
 1001 = Channel 09 (AN9)
 1010 = Channel 10 (AN10)
 1011 = Channel 11 (AN11)
 11xx = Unused
- bit 1 **GO/DONE:** A/D Conversion Status bit
 When ADON = 1:
 1 = A/D conversion in progress
 0 = A/D Idle
- bit 0 **ADON:** A/D On bit
 1 = A/D converter module is enabled
 0 = A/D converter module is disabled

PIC18F85J90 FAMILY

REGISTER 19-2: ADCON1: A/D CONTROL REGISTER 1

U-0	U-0	R/W-0	R/W-0	R/W-0	R/W-0	R/W-0	R/W-0
—	—	VCFG1	VCFG0	PCFG3	PCFG2	PCFG1	PCFG0
bit 7							bit 0

Legend:

R = Readable bit W = Writable bit U = Unimplemented bit, read as '0'
 -n = Value at POR '1' = Bit is set '0' = Bit is cleared x = Bit is unknown

- bit 7-6 **Unimplemented:** Read as '0'
- bit 5 **VCFG1:** Voltage Reference Configuration bit (VREF- source)
 1 = VREF- (AN2)
 0 = AVSS
- bit 4 **VCFG0:** Voltage Reference Configuration bit (VREF+ source)
 1 = VREF+ (AN3)
 0 = AVDD
- bit 3-0 **PCFG3:PCFG0:** A/D Port Configuration Control bits:

PCFG3: PCFG0	AN11	AN10	AN9	AN8	AN7	AN6	AN5	AN4	AN3	AN2	AN1	AN0
0000	A	A	A	A	A	A	A	A	A	A	A	A
0001	A	A	A	A	A	A	A	A	A	A	A	A
0010	A	A	A	A	A	A	A	A	A	A	A	A
0011	A	A	A	A	A	A	A	A	A	A	A	A
0100	D	A	A	A	A	A	A	A	A	A	A	A
0101	D	D	A	A	A	A	A	A	A	A	A	A
0110	D	D	D	A	A	A	A	A	A	A	A	A
0111	D	D	D	D	A	A	A	A	A	A	A	A
1000	D	D	D	D	D	A	A	A	A	A	A	A
1001	D	D	D	D	D	D	A	A	A	A	A	A
1010	D	D	D	D	D	D	D	A	A	A	A	A
1011	D	D	D	D	D	D	D	D	A	A	A	A
1100	D	D	D	D	D	D	D	D	D	A	A	A
1101	D	D	D	D	D	D	D	D	D	D	A	A
1110	D	D	D	D	D	D	D	D	D	D	D	A
1111	D	D	D	D	D	D	D	D	D	D	D	D

A = Analog input

D = Digital I/O

PIC18F85J90 FAMILY

REGISTER 19-3: ADCON2: A/D CONTROL REGISTER 2

R/W-0	U-0	R/W-0	R/W-0	R/W-0	R/W-0	R/W-0	R/W-0
ADFM	—	ACQT2	ACQT1	ACQT0	ADCS2	ADCS1	ADCS0
bit 7							bit 0

Legend:

R = Readable bit	W = Writable bit	U = Unimplemented bit, read as '0'
-n = Value at POR	'1' = Bit is set	'0' = Bit is cleared
		x = Bit is unknown

bit 7 **ADFM:** A/D Result Format Select bit

1 = Right justified

0 = Left justified

bit 6 **Unimplemented:** Read as '0'

bit 5-3 **ACQT2:ACQT0:** A/D Acquisition Time Select bits

111 = 20 TAD

110 = 16 TAD

101 = 12 TAD

100 = 8 TAD

011 = 6 TAD

010 = 4 TAD

001 = 2 TAD

000 = 0 TAD⁽¹⁾

bit 2-0 **ADCS2:ADCS0:** A/D Conversion Clock Select bits

111 = FRC (clock derived from A/D RC oscillator)⁽¹⁾

110 = FOSC/64

101 = FOSC/16

100 = FOSC/4

011 = FRC (clock derived from A/D RC oscillator)⁽¹⁾

010 = FOSC/32

001 = FOSC/8

000 = FOSC/2

Note 1: If the A/D FRC clock source is selected, a delay of one T_{cy} (instruction cycle) is added before the A/D clock starts. This allows the SLEEP instruction to be executed before starting a conversion.

PIC18F85J90 FAMILY

The analog reference voltage is software selectable to either the device's positive and negative supply voltage (AVDD and AVSS), or the voltage level on the RA3/AN3/VREF+ and RA2/AN2/VREF- pins.

The A/D converter has a unique feature of being able to operate while the device is in Sleep mode. To operate in Sleep, the A/D conversion clock must be derived from the A/D's internal RC oscillator.

The output of the sample and hold is the input into the converter, which generates the result via successive approximation.

Each port pin associated with the A/D converter can be configured as an analog input or as a digital I/O. The ADRESH and ADRESL registers contain the result of

the A/D conversion. When the A/D conversion is complete, the result is loaded into the ADRESH:ADRESL register pair, the GO/DONE bit (ADCON0<1>) is cleared and A/D Interrupt Flag bit, ADIF, is set.

A device Reset forces all registers to their Reset state. This forces the A/D module to be turned off and any conversion in progress is aborted. The value in the ADRESH:ADRESL register pair is not modified for a Power-on Reset. These registers will contain unknown data after a Power-on Reset.

The block diagram of the A/D module is shown in Figure 19-1.

FIGURE 19-1: A/D BLOCK DIAGRAM^(1,2)

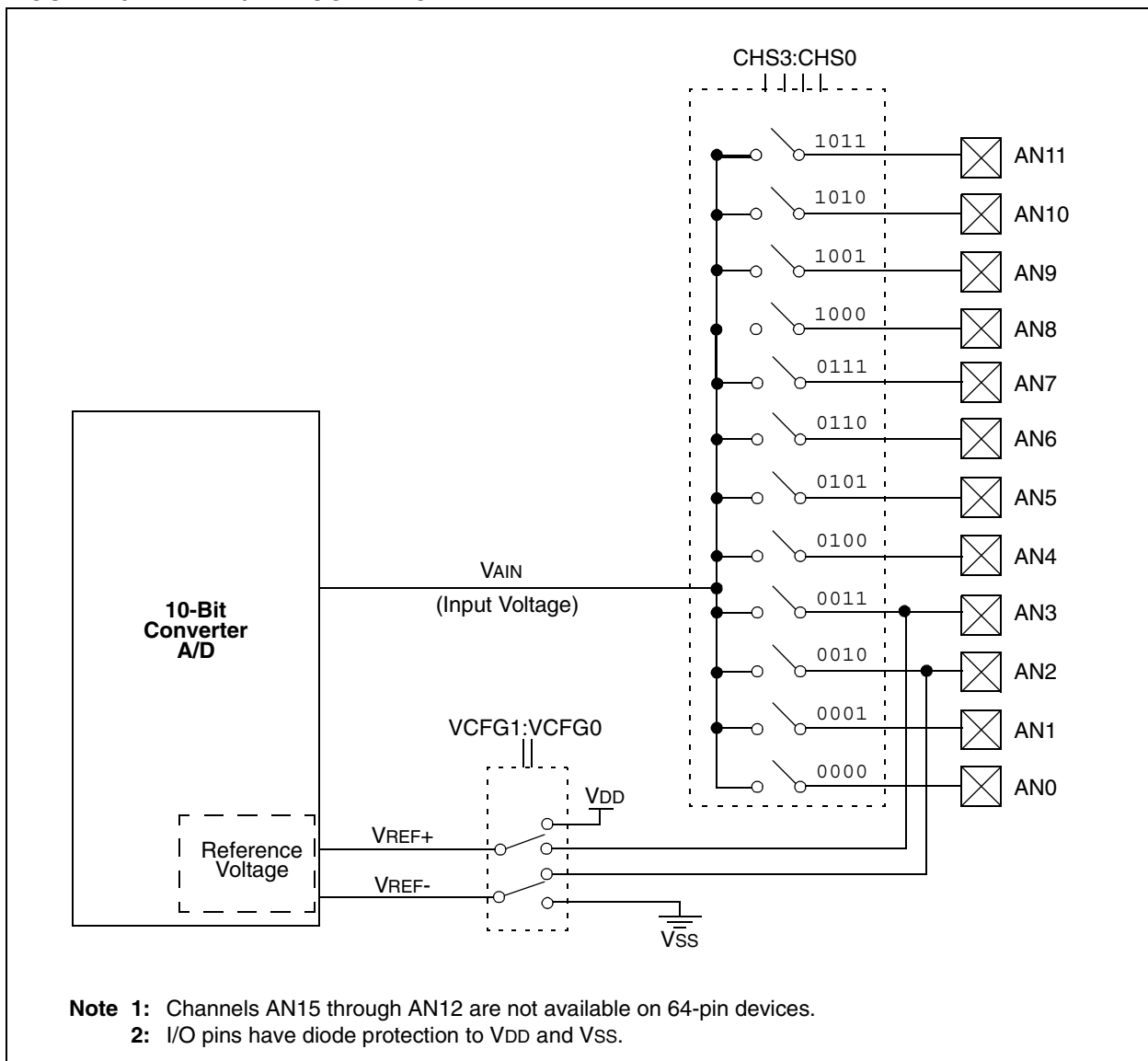

PIC18F85J90 FAMILY

After the A/D module has been configured as desired, the selected channel must be acquired before the conversion is started. The analog input channels must have their corresponding TRIS bits selected as an input. To determine acquisition time, see **Section 19.1 “A/D Acquisition Requirements”**. After this acquisition time has elapsed, the A/D conversion can be started. An acquisition time can be programmed to occur between setting the GO/DONE bit and the actual start of the conversion.

The following steps should be followed to do an A/D conversion:

1. Configure the A/D module:
 - Configure analog pins, voltage reference and digital I/O (ADCON1)
 - Select A/D input channel (ADCON0)
 - Select A/D acquisition time (ADCON2)
 - Select A/D conversion clock (ADCON2)
 - Turn on A/D module (ADCON0)
2. Configure A/D interrupt (if desired):
 - Clear ADIF bit
 - Set ADIE bit
 - Set GIE bit
3. Wait the required acquisition time (if required).
4. Start conversion:
 - Set GO/DONE bit (ADCON0<1>)
5. Wait for A/D conversion to complete, by either:
 - Polling for the GO/DONE bit to be cleared
 OR
 - Waiting for the A/D interrupt
6. Read A/D Result registers (ADRESH:ADRESL); clear ADIF bit, if required.
7. For next conversion, go to step 1 or step 2, as required. The A/D conversion time per bit is defined as TAD. A minimum wait of 2 TAD is required before next acquisition starts.

FIGURE 19-2: ANALOG INPUT MODEL

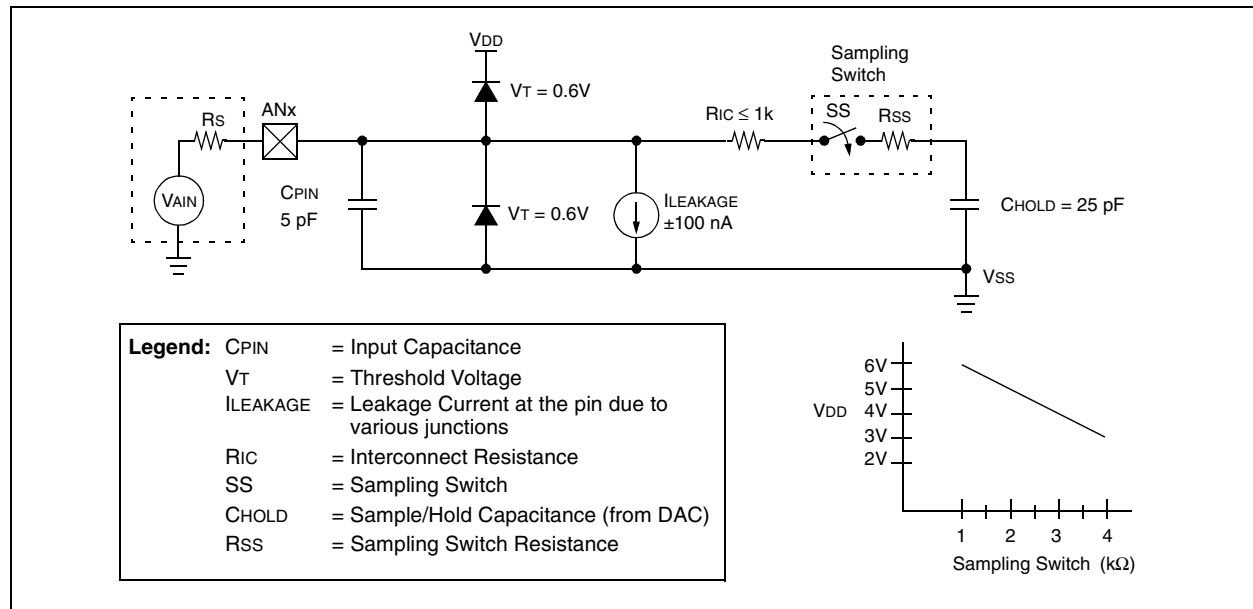

PIC18F85J90 FAMILY

19.1 A/D Acquisition Requirements

For the A/D converter to meet its specified accuracy, the charge holding capacitor (CHOLD) must be allowed to fully charge to the input channel voltage level. The analog input model is shown in Figure 19-2. The source impedance (Rs) and the internal sampling switch (Rss) impedance directly affect the time required to charge the capacitor CHOLD. The sampling switch (Rss) impedance varies over the device voltage (VDD). The source impedance affects the offset voltage at the analog input (due to pin leakage current). **The maximum recommended impedance for analog sources is 2.5 kΩ.** After the analog input channel is selected (changed), the channel must be sampled for at least the minimum acquisition time before starting a conversion.

Note: When the conversion is started, the holding capacitor is disconnected from the input pin.

To calculate the minimum acquisition time, Equation 19-1 may be used. This equation assumes that 1/2 LSB error is used (1024 steps for the A/D). The 1/2 LSB error is the maximum error allowed for the A/D to meet its specified resolution.

Equation 19-3 shows the calculation of the minimum required acquisition time, TACQ. This calculation is based on the following application system assumptions:

CHOLD	=	25 pF
Rs	=	2.5 kΩ
Conversion Error	≤	1/2 LSB
VDD	=	3V → Rss = 2 kΩ
Temperature	=	85°C (system max.)

EQUATION 19-1: ACQUISITION TIME

$$\begin{aligned} TACQ &= \text{Amplifier Settling Time} + \text{Holding Capacitor Charging Time} + \text{Temperature Coefficient} \\ &= TAMP + TC + TCOFF \end{aligned}$$

EQUATION 19-2: A/D MINIMUM CHARGING TIME

$$\begin{aligned} V_{HOLD} &= (V_{REF} - (V_{REF}/2048)) \cdot (1 - e^{-(TC/CHOLD)(RIC + R_{SS} + R_S)}) \\ \text{or} \\ TC &= -(CHOLD)(RIC + R_{SS} + R_S) \ln(1/2048) \end{aligned}$$

EQUATION 19-3: CALCULATING THE MINIMUM REQUIRED ACQUISITION TIME

$$\begin{aligned} TACQ &= TAMP + TC + TCOFF \\ TAMP &= 0.2 \mu s \\ TCOFF &= \frac{(Temp - 25^\circ C)(0.02 \mu s/^\circ C)}{(85^\circ C - 25^\circ C)(0.02 \mu s/^\circ C)} \\ &= 1.2 \mu s \end{aligned}$$

Temperature coefficient is only required for temperatures > 25°C. Below 25°C, TCOFF = 0 ms.

$$\begin{aligned} TC &= -(CHOLD)(RIC + R_{SS} + R_S) \ln(1/2048) \mu s \\ &= (25 \text{ pF})(1 \text{ k}\Omega + 2 \text{ k}\Omega + 2.5 \text{ k}\Omega) \ln(0.0004883) \mu s \\ &= 1.05 \mu s \end{aligned}$$

$$\begin{aligned} TACQ &= 0.2 \mu s + 1 \mu s + 1.2 \mu s \\ &= 2.4 \mu s \end{aligned}$$

19.2 Selecting and Configuring Automatic Acquisition Time

The ADCON2 register allows the user to select an acquisition time that occurs each time the $\overline{\text{GO/DONE}}$ bit is set.

When the $\overline{\text{GO/DONE}}$ bit is set, sampling is stopped and a conversion begins. The user is responsible for ensuring the required acquisition time has passed between selecting the desired input channel and setting the $\overline{\text{GO/DONE}}$ bit. This occurs when the ACQT2:ACQT0 bits (ADCON2<5:3>) remain in their Reset state ('000') and is compatible with devices that do not offer programmable acquisition times.

If desired, the ACQT bits can be set to select a programmable acquisition time for the A/D module. When the $\overline{\text{GO/DONE}}$ bit is set, the A/D module continues to sample the input for the selected acquisition time, then automatically begins a conversion. Since the acquisition time is programmed, there may be no need to wait for an acquisition time between selecting a channel and setting the $\overline{\text{GO/DONE}}$ bit.

In either case, when the conversion is completed, the $\overline{\text{GO/DONE}}$ bit is cleared, the ADIF flag is set and the A/D begins sampling the currently selected channel again. If an acquisition time is programmed, there is nothing to indicate if the acquisition time has ended or if the conversion has begun.

19.3 Selecting the A/D Conversion Clock

The A/D conversion time per bit is defined as TAD. The A/D conversion requires 11 TAD per 10-bit conversion. The source of the A/D conversion clock is software selectable.

There are seven possible options for TAD:

- 2 TOSC
- 4 TOSC
- 8 TOSC
- 16 TOSC
- 32 TOSC
- 64 TOSC
- Internal RC Oscillator

For correct A/D conversions, the A/D conversion clock (TAD) must be as short as possible but greater than the minimum TAD (see parameter 130 in Table 25-25 for more information).

Table 19-1 shows the resultant TAD times derived from the device operating frequencies and the A/D clock source selected.

TABLE 19-1: TAD vs. DEVICE OPERATING FREQUENCIES

AD Clock Source (TAD)		Maximum Device Frequency
Operation	ADCS2:ADCS0	
2 TOSC	000	2.86 MHz
4 TOSC	100	5.71 MHz
8 TOSC	001	11.43 MHz
16 TOSC	101	22.86 MHz
32 TOSC	010	40.0 MHz
64 TOSC	110	40.0 MHz
RC ⁽²⁾	x11	1.00 MHz ⁽¹⁾

Note 1: The RC source has a typical TAD time of 4 μs .

2: For device frequencies above 1 MHz, the device must be in Sleep mode for the entire conversion or the A/D accuracy may be out of specification.

19.4 Configuring Analog Port Pins

The ADCON1, TRISA, TRISF and TRISH registers control the operation of the A/D port pins. The port pins needed as analog inputs must have their corresponding TRIS bits set (input). If the TRIS bit is cleared (output), the digital output level (VOH or VOL) will be converted.

The A/D operation is independent of the state of the CHS3:CHS0 bits and the TRIS bits.

Note 1: When reading the PORT register, all pins configured as analog input channels will read as cleared (a low level). Pins configured as digital inputs will convert an analog input. Analog levels on a digitally configured input will be accurately converted.

2: Analog levels on any pin defined as a digital input may cause the digital input buffer to consume current out of the device's specification limits.

PIC18F85J90 FAMILY

19.5 A/D Conversions

Figure 19-3 shows the operation of the A/D converter after the $\overline{\text{GO/DONE}}$ bit has been set and the ACQT2:ACQT0 bits are cleared. A conversion is started after the following instruction to allow entry into Sleep mode before the conversion begins.

Figure 19-4 shows the operation of the A/D converter after the $\overline{\text{GO/DONE}}$ bit has been set, the ACQT2:ACQT0 bits are set to '010' and selecting a 4 TAD acquisition time before the conversion starts.

Clearing the $\overline{\text{GO/DONE}}$ bit during a conversion will abort the current conversion. The A/D Result register pair will NOT be updated with the partially completed A/D conversion sample. This means the ADRESH:ADRESL registers will continue to contain the value of the last completed conversion (or the last value written to the ADRESH:ADRESL registers).

After the A/D conversion is completed or aborted, a 2 TAD wait is required before the next acquisition can be started. After this wait, acquisition on the selected channel is automatically started.

Note: The $\overline{\text{GO/DONE}}$ bit should **NOT** be set in the same instruction that turns on the A/D.

19.6 Use of the CCP2 Trigger

An A/D conversion can be started by the "Special Event Trigger" of the CCP2 module. This requires that the CCP2M3:CCP2M0 bits (CCP2CON<3:0>) be programmed as '1011' and that the A/D module is enabled (ADON bit is set). When the trigger occurs, the $\overline{\text{GO/DONE}}$ bit will be set, starting the A/D acquisition and conversion and the Timer1 (or Timer3) counter will be reset to zero. Timer1 (or Timer3) is reset to automatically repeat the A/D acquisition period with minimal software overhead (moving ADRESH/ADRESL to the desired location). The appropriate analog input channel must be selected and the minimum acquisition period is either timed by the user, or an appropriate TACQ time is selected before the Special Event Trigger sets the $\overline{\text{GO/DONE}}$ bit (starts a conversion).

If the A/D module is not enabled (ADON is cleared), the Special Event Trigger will be ignored by the A/D module but will still reset the Timer1 (or Timer3) counter.

FIGURE 19-3: A/D CONVERSION TAD CYCLES (ACQT2:ACQT0 = 000, TACQ = 0)

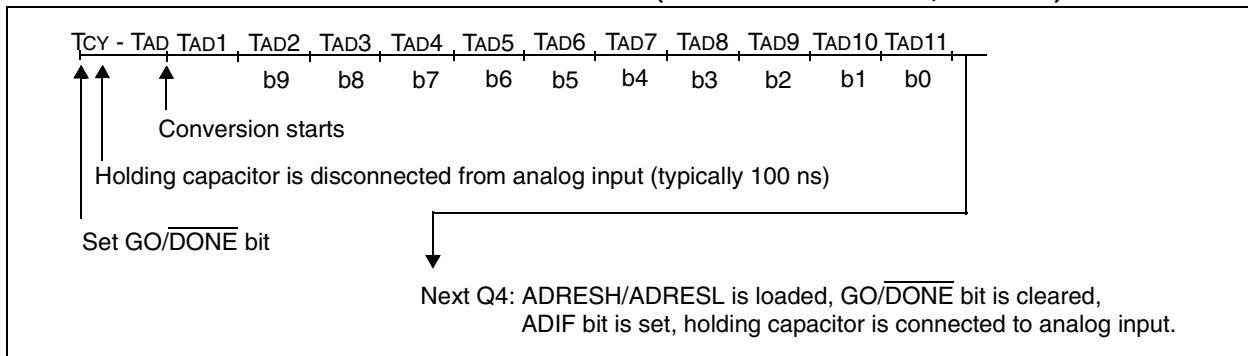
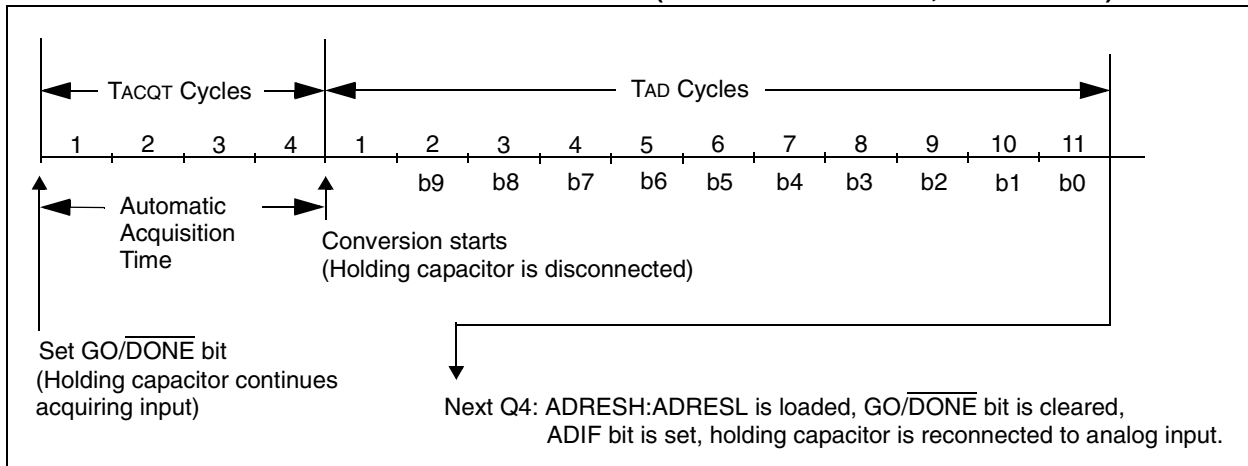

FIGURE 19-4: A/D CONVERSION TAD CYCLES (ACQT2:ACQT0 = 010, TACQ = 4 TAD)



PIC18F85J90 FAMILY

19.7 A/D Converter Calibration

The A/D converter in the PIC18F85J90 family of devices includes a self-calibration feature which compensates for any offset generated within the module. The calibration process is automated and is initiated by setting the ADCAL bit (ADCON0<7>). The next time the GO/DONE bit is set, the module will perform a “dummy” conversion (that is, with reading none of the input channels) and store the resulting value internally to compensate for offset. Thus, subsequent offsets will be compensated.

The calibration process assumes that the device is in a relatively steady-state operating condition. If A/D calibration is used, it should be performed after each device Reset or if there are other major changes in operating conditions.

19.8 Operation in Power-Managed Modes

The selection of the automatic acquisition time and A/D conversion clock is determined in part by the clock source and frequency while in a power-managed mode.

If the A/D is expected to operate while the device is in a power-managed mode, the ACQT2:ACQT0 and ADCS2:ADCS0 bits in ADCON2 should be updated in accordance with the power-managed mode clock that will be used. After the power-managed mode is entered (either of the power-managed Run modes), an A/D acquisition or conversion may be started. Once an acquisition or conversion is started, the device should continue to be clocked by the same power-managed mode clock source until the conversion has been completed. If desired, the device may be placed into the corresponding power-managed Idle mode during the conversion.

If the power-managed mode clock frequency is less than 1 MHz, the A/D RC clock source should be selected.

Operation in the Sleep mode requires the A/D RC clock to be selected. If bits ACQT2:ACQT0 are set to ‘000’ and a conversion is started, the conversion will be delayed one instruction cycle to allow execution of the SLEEP instruction and entry to Sleep mode. The IDLEN and SCS bits in the OSCCON register must have already been cleared prior to starting the conversion.

TABLE 19-2: SUMMARY OF A/D REGISTERS

Name	Bit 7	Bit 6	Bit 5	Bit 4	Bit 3	Bit 2	Bit 1	Bit 0	Reset Values on page
INTCON	GIE/GIEH	PEIE/GIEL	TMR0IE	INT0IE	RBIE	TMR0IF	INT0IF	RBIF	51
PIR1	—	ADIF	RC1IF	TX1IF	SSPIF	—	TMR2IF	TMR1IF	54
PIE1	—	ADIE	RC1IE	TX1IE	SSPIE	—	TMR2IE	TMR1IE	54
IPR1	—	ADIP	RC1IP	TX1IP	SSPIP	—	TMR2IP	TMR1IP	54
PIR3	—	LCDIF	RC2IF	TX2IF	—	CCP2IF	CCP1IF	—	54
PIE3	—	LCDIE	RC2IE	TX2IE	—	CCP2IE	CCP1IE	—	54
IPR3	—	LCDIP	RC2IP	TX2IP	—	CCP2IP	CCP1IP	—	54
ADRESH	A/D Result Register High Byte								53
ADRESL	A/D Result Register Low Byte								53
ADCON0	ADCAL	—	CHS3	CHS3	CHS1	CHS0	GO/DONE	ADON	53
ADCON1	—	—	VCFG1	VCFG0	PCFG3	PCFG2	PCFG1	PCFG0	53
ADCON2	ADFM	—	ACQT2	ACQT1	ACQT0	ADCS2	ADCS1	ADCS0	53
CCP2CON	—	—	DC2B1	DC2B0	CCP2M3	CCP2M2	CCP2M1	CCP2M0	55
PORTA	RA7 ⁽¹⁾	RA6 ⁽¹⁾	RA5	RA4	RA3	RA2	RA1	RA0	55
TRISA	TRISA7 ⁽¹⁾	TRISA6 ⁽¹⁾	TRISA5	TRISA4	TRISA3	TRISA2	TRISA1	TRISA0	54
PORTF	RF7	RF6	RF5	RF4	RF3	RF2	RF1	—	54
TRISF	TRISF5	TRISF4	TRISF5	TRISF4	TRISF3	TRISF2	TRISF1	—	54

Legend: — = unimplemented, read as ‘0’. Shaded cells are not used for A/D conversion.

Note 1: RA6/RA7 and their associated latch and direction bits are configured as port pins only when the internal oscillator is selected as the default clock source (FOSC2 Configuration bit = 0); otherwise, they are disabled and these bits read as ‘0’.

PIC18F85J90 FAMILY

NOTES:

PIC18F85J90 FAMILY

20.0 COMPARATOR MODULE

The analog comparator module contains two comparators that can be configured in a variety of ways. The inputs can be selected from the analog inputs multiplexed with pins RF1 through RF6, as well as the on-chip voltage reference (see **Section 21.0 “Comparator Voltage Reference Module”**). The digital outputs (normal or inverted) are available at the pin level and can also be read through the control register.

The CMCON register (Register 20-1) selects the comparator input and output configuration. Block diagrams of the various comparator configurations are shown in Figure 20-1.

REGISTER 20-1: CMCON: COMPARATOR MODULE CONTROL REGISTER

R-0	R-0	R/W-0	R/W-0	R/W-0	R/W-1	R/W-1	R/W-1
C2OUT	C1OUT	C2INV	C1INV	CIS	CM2	CM1	CM0
bit 7							bit 0

Legend:

R = Readable bit
-n = Value at POR

W = Writable bit
'1' = Bit is set

U = Unimplemented bit, read as '0'
'0' = Bit is cleared
x = Bit is unknown

bit 7 **C2OUT:** Comparator 2 Output bit

When C2INV = 0:

1 = C2 VIN+ > C2 VIN-
0 = C2 VIN+ < C2 VIN-

When C2INV = 1:

1 = C2 VIN+ < C2 VIN-
0 = C2 VIN+ > C2 VIN-

bit 6 **C1OUT:** Comparator 1 Output bit

When C1INV = 0:

1 = C1 VIN+ > C1 VIN-
0 = C1 VIN+ < C1 VIN-

When C1INV = 1:

1 = C1 VIN+ < C1 VIN-
0 = C1 VIN+ > C1 VIN-

bit 5 **C2INV:** Comparator 2 Output Inversion bit

1 = C2 output inverted
0 = C2 output not inverted

bit 4 **C1INV:** Comparator 1 Output Inversion bit

1 = C1 output inverted
0 = C1 output not inverted

bit 3 **CIS:** Comparator Input Switch bit

When CM2:CM0 = 110:

1 = C1 VIN- connects to RF5/AN10/CVREF
 C2 VIN- connects to RF3/AN8
0 = C1 VIN- connects to RF6/AN11
 C2 VIN- connects to RF4/AN9

bit 2-0 **CM2:CM0:** Comparator Mode bits

Figure 20-1 shows the Comparator modes and the CM2:CM0 bit settings.

PIC18F85J90 FAMILY

20.1 Comparator Configuration

There are eight modes of operation for the comparators, shown in Figure 20-1. Bits CM2:CM0 of the CMCON register are used to select these modes. The TRISF register controls the data direction of the comparator pins for each mode. If the Comparator

mode is changed, the comparator output level may not be valid for the specified mode change delay shown in Section 25.0 “Electrical Characteristics”.

Note: Comparator interrupts should be disabled during a Comparator mode change; otherwise, a false interrupt may occur.

FIGURE 20-1: COMPARATOR I/O OPERATING MODES

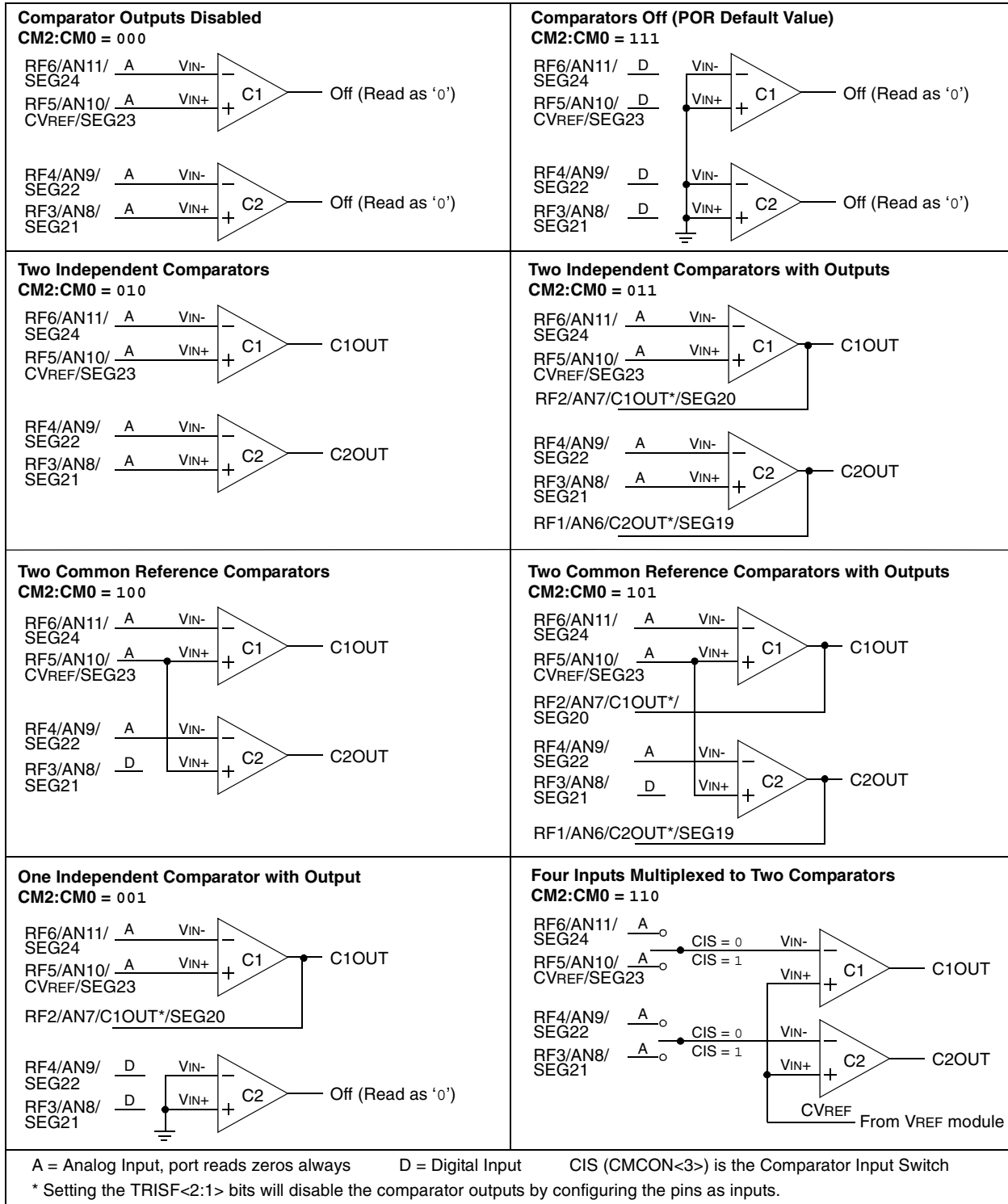

20.2 Comparator Operation

A single comparator is shown in Figure 20-2, along with the relationship between the analog input levels and the digital output. When the analog input at V_{IN+} is less than the analog input V_{IN-} , the output of the comparator is a digital low level. When the analog input at V_{IN+} is greater than the analog input V_{IN-} , the output of the comparator is a digital high level. The shaded areas of the output of the comparator in Figure 20-2 represent the uncertainty due to input offsets and response time.

20.3 Comparator Reference

Depending on the comparator operating mode, either an external or internal voltage reference may be used. The analog signal present at V_{IN-} is compared to the signal at V_{IN+} and the digital output of the comparator is adjusted accordingly (Figure 20-2).

FIGURE 20-2: SINGLE COMPARATOR

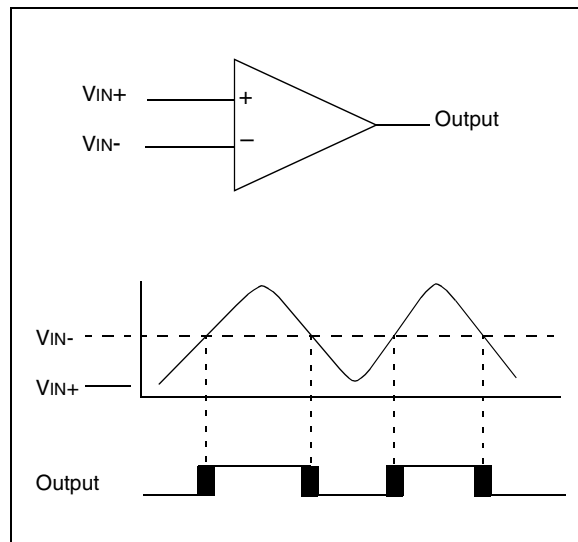

20.3.1 EXTERNAL REFERENCE SIGNAL

When external voltage references are used, the comparator module can be configured to have the comparators operate from the same or different reference sources. However, threshold detector applications may require the same reference. The reference signal must be between V_{SS} and V_{DD} and can be applied to either pin of the comparator(s).

20.3.2 INTERNAL REFERENCE SIGNAL

The comparator module also allows the selection of an internally generated voltage reference from the comparator voltage reference module. This module is described in more detail in **Section 21.0 “Comparator Voltage Reference Module”**.

The internal reference is only available in the mode where four inputs are multiplexed to two comparators ($CM2:CM0 = 110$). In this mode, the internal voltage reference is applied to the V_{IN+} pin of both comparators.

20.4 Comparator Response Time

Response time is the minimum time, after selecting a new reference voltage or input source, before the comparator output has a valid level. If the internal reference is changed, the maximum delay of the internal voltage reference must be considered when using the comparator outputs. Otherwise, the maximum delay of the comparators should be used (see **Section 25.0 “Electrical Characteristics”**).

20.5 Comparator Outputs

The comparator outputs are read through the $CMCON$ register. These bits are read-only. The comparator outputs may also be directly output to the RF1 and RF2 I/O pins. When enabled, multiplexors in the output path of each pin will be the unsynchronized output of the comparator. The uncertainty of each of the comparators is related to the input offset voltage and the response time given in the specifications. Figure 20-3 shows the comparator output block diagram.

The TRISF bits will still function as an output enable/disable for the RF1 and RF2 pins while in this mode.

The polarity of the comparator outputs can be changed using the C2INV and C1INV bits ($CMCON<5:4>$).

- Note 1:** When reading the PORT register, all pins configured as analog inputs will read as '0'. Pins configured as digital inputs will convert an analog input according to the Schmitt Trigger input specification.
- 2:** Analog levels on any pin defined as a digital input may cause the input buffer to consume more current than is specified.

PIC18F85J90 FAMILY

FIGURE 20-3: COMPARATOR OUTPUT BLOCK DIAGRAM

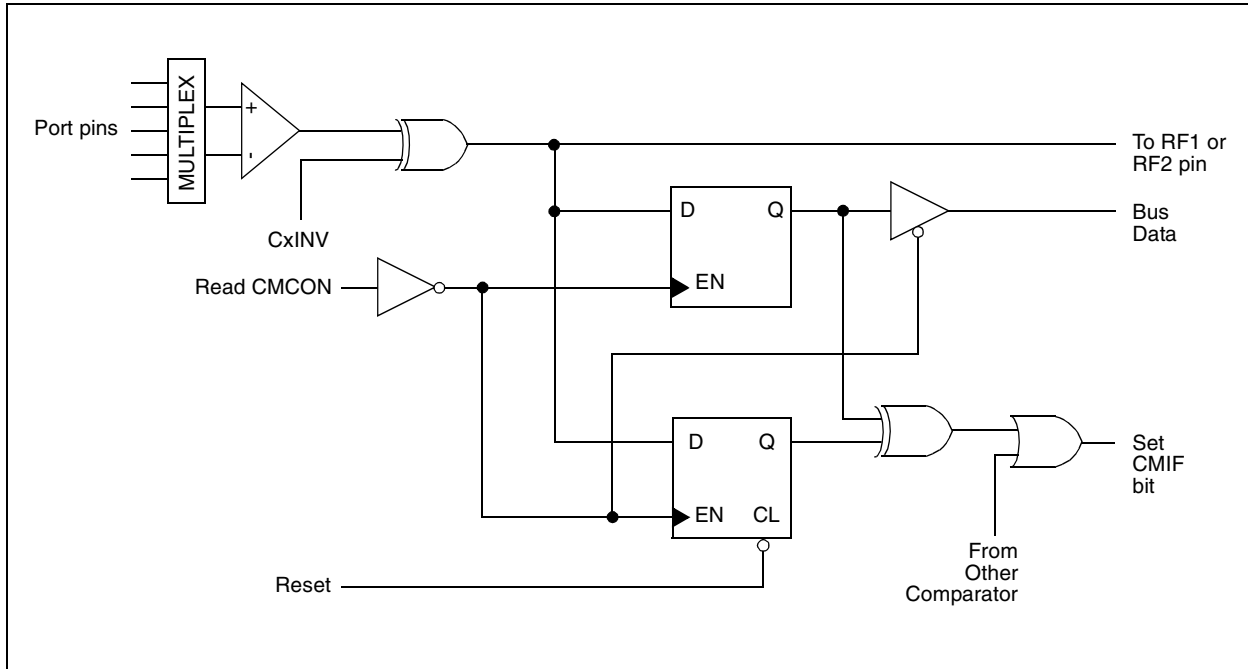

20.6 Comparator Interrupts

The comparator interrupt flag is set whenever there is a change in the output value of either comparator. Software will need to maintain information about the status of the output bits, as read from CMCON<7:6>, to determine the actual change that occurred. The CMIF bit (PIR2<6>) is the Comparator Interrupt Flag. The CMIF bit must be reset by clearing it. Since it is also possible to write a '1' to this register, a simulated interrupt may be initiated.

Both the CMIE bit (PIE2<6>) and the PEIE bit (INTCON<6>) must be set to enable the interrupt. In addition, the GIE bit (INTCON<7>) must also be set. If any of these bits are clear, the interrupt is not enabled, though the CMIF bit will still be set if an interrupt condition occurs.

Note: If a change in the CMCON register (C1OUT or C2OUT) should occur when a read operation is being executed (start of the Q2 cycle), then the CMIF (PIR2<6>) interrupt flag may not get set.

The user, in the Interrupt Service Routine, can clear the interrupt in the following manner:

- Any read or write of CMCON will end the mismatch condition.
- Clear flag bit CMIF.

A mismatch condition will continue to set flag bit CMIF. Reading CMCON will end the mismatch condition and allow flag bit CMIF to be cleared.

20.7 Comparator Operation During Sleep

When a comparator is active and the device is placed in Sleep mode, the comparator remains active and the interrupt is functional, if enabled. This interrupt will wake-up the device from Sleep mode, when enabled. Each operational comparator will consume additional current, as shown in the comparator specifications. To minimize power consumption while in Sleep mode, turn off the comparators (CM2:CM0 = 111) before entering Sleep. If the device wakes up from Sleep, the contents of the CMCON register are not affected.

20.8 Effects of a Reset

A device Reset forces the CMCON register to its Reset state, causing the comparator modules to be turned off (CM2:CM0 = 111). However, the input pins (RF3 through RF6) are configured as analog inputs by default on device Reset. The I/O configuration for these pins is determined by the setting of the PCFG3:PCFG0 bits (ADCON1<3:0>). Therefore, device current is minimized when analog inputs are present at Reset time.

20.9 Analog Input Connection Considerations

A simplified circuit for an analog input is shown in Figure 20-4. Since the analog pins are connected to a digital output, they have reverse biased diodes to VDD and VSS. The analog input, therefore, must be between VSS and VDD. If the input voltage deviates from this

range by more than 0.6V in either direction, one of the diodes is forward biased and a latch-up condition may occur. A maximum source impedance of 10 kΩ is recommended for the analog sources. Any external component connected to an analog input pin, such as a capacitor or a Zener diode, should have very little leakage current.

FIGURE 20-4: COMPARATOR ANALOG INPUT MODEL

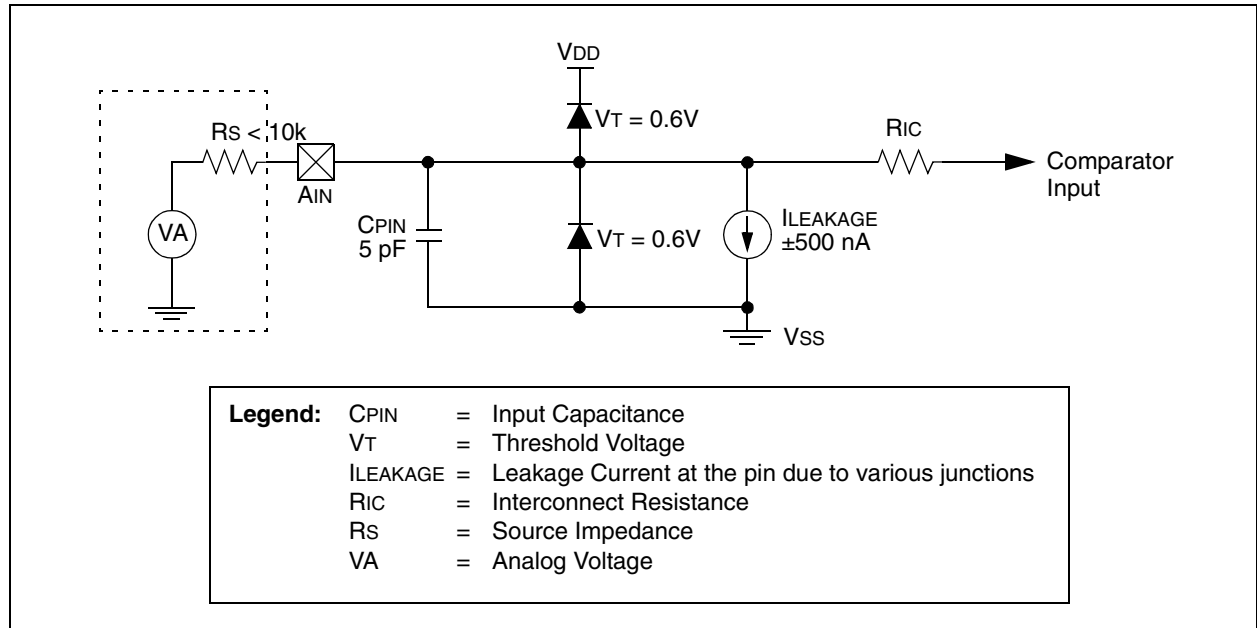

TABLE 20-1: REGISTERS ASSOCIATED WITH COMPARATOR MODULE

Name	Bit 7	Bit 6	Bit 5	Bit 4	Bit 3	Bit 2	Bit 1	Bit 0	Reset Values on page
INTCON	GIE/GIEH	PEIE/GIEL	TMR0IE	INT0IE	RBIE	TMR0IF	INT0IF	RBIF	51
PIR2	OSCFIF	CMIF	—	—	BCLIF	LVDIF	TMR3IF	—	54
PIE2	OSCFIE	CMIE	—	—	BCLIE	LVDIE	TMR3IE	—	54
IPR2	OSCFIP	CMIP	—	—	BCLIP	LVDIP	TMR3IP	—	54
CMCON	C2OUT	C1OUT	C2INV	C1INV	CIS	CM2	CM1	CM0	53
CVRCON	CVREN	CVROE	CVRR	CVRSS	CVR3	CVR2	CVR1	CVR0	53
PORTF	RF7	RF6	RF5	RF4	RF3	RF2	RF1	—	54
LATF	LATF7	LATF6	LATF5	LATF4	LATF3	LATF2	LATF1	—	54
TRISF	TRISF7	TRISF6	TRISF5	TRISF4	TRISF3	TRISF2	TRISF1	—	54

Legend: — = unimplemented, read as '0'. Shaded cells are unused by the comparator module.

PIC18F85J90 FAMILY

NOTES:

21.0 COMPARATOR VOLTAGE REFERENCE MODULE

The comparator voltage reference is a 16-tap resistor ladder network that provides a selectable reference voltage. Although its primary purpose is to provide a reference for the analog comparators, it may also be used independently of them.

A block diagram of the module is shown in Figure 21-1. The resistor ladder is segmented to provide two ranges of CVREF values and has a power-down function to conserve power when the reference is not being used. The module's supply reference can be provided from either device VDD/VSS or an external voltage reference.

21.1 Configuring the Comparator Voltage Reference

The comparator voltage reference module is controlled through the CVRCON register (Register 21-1). The comparator voltage reference provides two ranges of output voltage, each with 16 distinct levels.

The range to be used is selected by the CVRR bit (CVRCON<5>). The primary difference between the ranges is the size of the steps selected by the CVREF Selection bits (CVR3:CVR0), with one range offering finer resolution. The equations used to calculate the output of the comparator voltage reference are as follows:

If CVRR = 1:

$$CVREF = ((CVR3:CVR0)/24) \times (CVRSRC)$$

If CVRR = 0:

$$CVREF = (CVRSRC/4) + ((CVR3:CVR0)/32) \times (CVRSRC)$$

The comparator reference supply voltage can come from either VDD and VSS, or the external VREF+ and VREF- that are multiplexed with RA2 and RA3. The voltage source is selected by the CVRSS bit (CVRCON<4>).

The settling time of the comparator voltage reference must be considered when changing the CVREF output (see Table 25-3 in **Section 25.0 "Electrical Characteristics"**).

REGISTER 21-1: CVRCON: COMPARATOR VOLTAGE REFERENCE CONTROL REGISTER

R/W-0	R/W-0	R/W-0	R/W-0	R/W-0	R/W-0	R/W-0	R/W-0
CVREN	CVROE ⁽¹⁾	CVRR	CVRSS	CVR3	CVR2	CVR1	CVR0
bit 7							bit 0

Legend:

R = Readable bit

W = Writable bit

U = Unimplemented bit, read as '0'

-n = Value at POR

'1' = Bit is set

'0' = Bit is cleared

x = Bit is unknown

- bit 7 **CVREN:** Comparator Voltage Reference Enable bit
1 = CVREF circuit powered on
0 = CVREF circuit powered down
- bit 6 **CVROE:** Comparator VREF Output Enable bit⁽¹⁾
1 = CVREF voltage level is also output on the RF5/AN10/CVREF/SEG23 pin
0 = CVREF voltage is disconnected from the RF5/AN10/CVREF/SEG23 pin
- bit 5 **CVRR:** Comparator VREF Range Selection bit
1 = 0 to 0.667 CVRSRC, with CVRSRC/24 step size (low range)
0 = 0.25 CVRSRC to 0.75 CVRSRC, with CVRSRC/32 step size (high range)
- bit 4 **CVRSS:** Comparator VREF Source Selection bit
1 = Comparator reference source, CVRSRC = (VREF+) – (VREF-)
0 = Comparator reference source, CVRSRC = VDD – VSS
- bit 3-0 **CVR3:CVR0:** Comparator VREF Value Selection bits (0 ≤ (CVR3:CVR0) ≤ 15)
When CVRR = 1:
CVREF = ((CVR3:CVR0)/24) • (CVRSRC)
When CVRR = 0:
CVREF = (CVRSRC/4) + ((CVR3:CVR0)/32) • (CVRSRC)

Note 1: CVROE overrides the TRISF<5> bit setting.

PIC18F85J90 FAMILY

FIGURE 21-1: COMPARATOR VOLTAGE REFERENCE BLOCK DIAGRAM

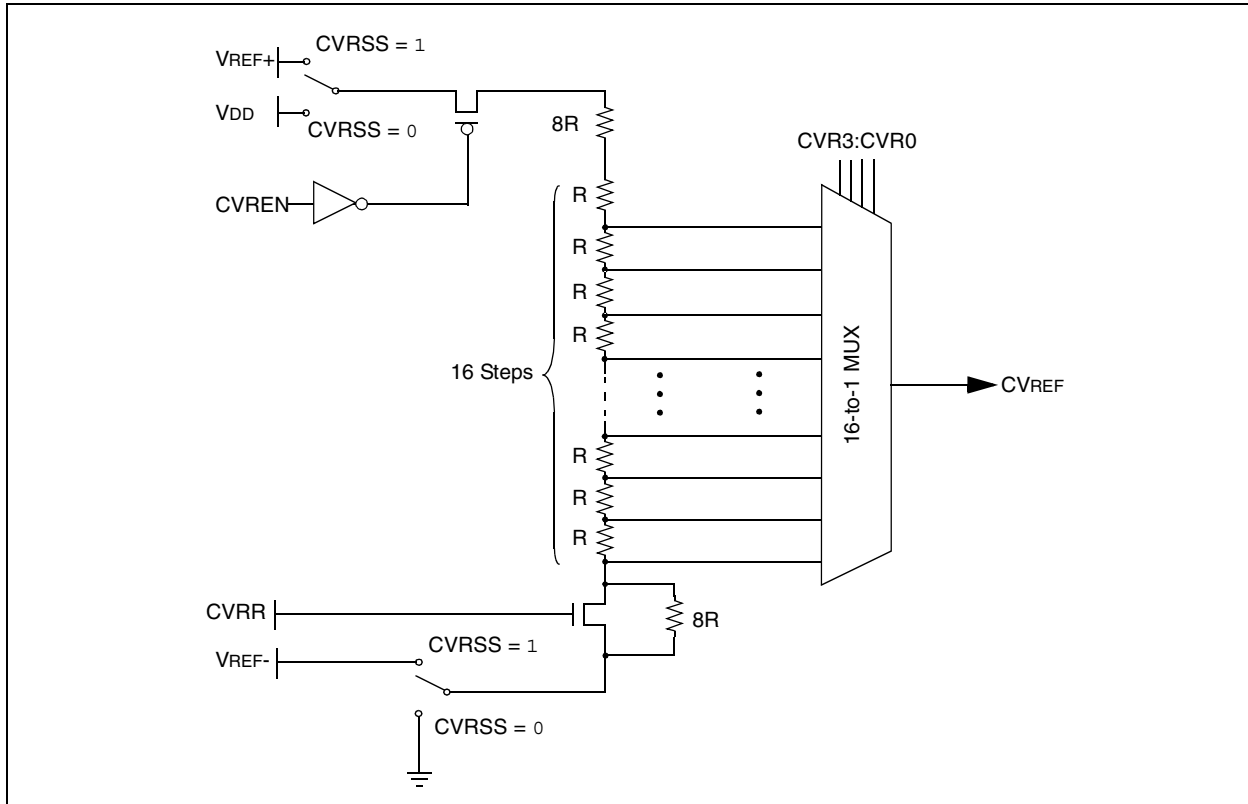

21.2 Voltage Reference Accuracy/Error

The full range of voltage reference cannot be realized due to the construction of the module. The transistors on the top and bottom of the resistor ladder network (Figure 21-1) keep CVREF from approaching the reference source rails. The voltage reference is derived from the reference source; therefore, the CVREF output changes with fluctuations in that source. The tested absolute accuracy of the voltage reference can be found in **Section 25.0 “Electrical Characteristics”**.

21.3 Operation During Sleep

When the device wakes up from Sleep through an interrupt or a Watchdog Timer time-out, the contents of the CVRCON register are not affected. To minimize current consumption in Sleep mode, the voltage reference should be disabled.

21.4 Effects of a Reset

A device Reset disables the voltage reference by clearing bit, CVREN (CVRCON<7>). This Reset also disconnects the reference from the RA2 pin by clearing bit, CVROE (CVRCON<6>) and selects the high-voltage range by clearing bit, CVRR (CVRCON<5>). The CVR value select bits are also cleared.

21.5 Connection Considerations

The voltage reference module operates independently of the comparator module. The output of the reference generator may be connected to the RF5 pin if the CVROE bit is set. Enabling the voltage reference output onto RA2 when it is configured as a digital input will increase current consumption. Connecting RF5 as a digital output with CVRSS enabled will also increase current consumption.

The RF5 pin can be used as a simple D/A output with limited drive capability. Due to the limited current drive capability, a buffer must be used on the voltage reference output for external connections to VREF. Figure 21-2 shows an example buffering technique.

PIC18F85J90 FAMILY

FIGURE 21-2: COMPARATOR VOLTAGE REFERENCE OUTPUT BUFFER EXAMPLE

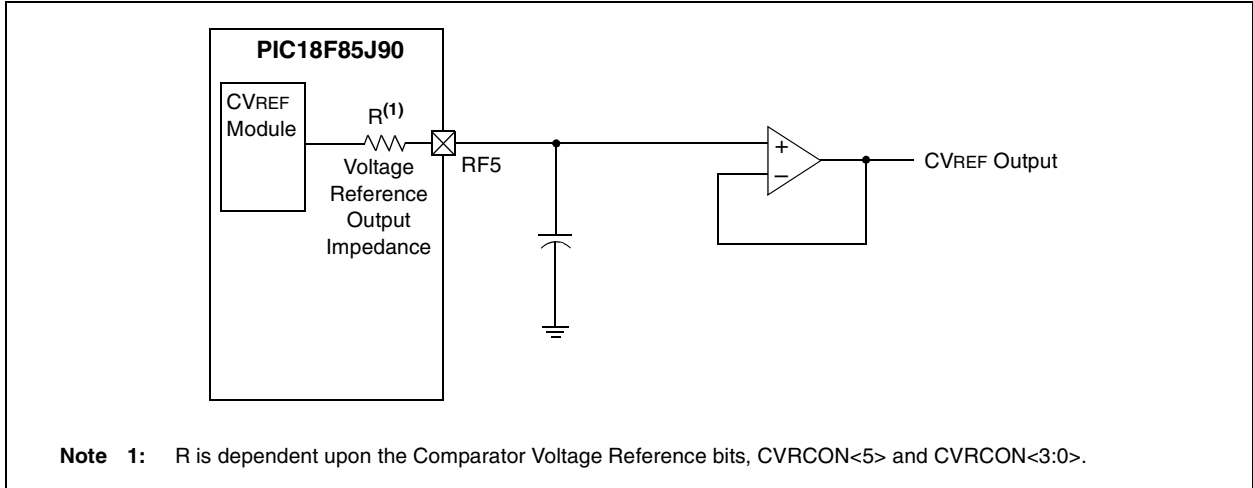

TABLE 21-1: REGISTERS ASSOCIATED WITH COMPARATOR VOLTAGE REFERENCE

Name	Bit 7	Bit 6	Bit 5	Bit 4	Bit 3	Bit 2	Bit 1	Bit 0	Reset Values on page
CVRCON	CVREN	CVROE	CVRR	CVRSS	CVR3	CVR2	CVR1	CVR0	53
CMCON	C2OUT	C1OUT	C2INV	C1INV	CIS	CM2	CM1	CM0	53
TRISF	TRISF7	TRISF6	TRISF5	TRISF4	TRISF3	TRISF2	TRISF1	—	54

Legend: — = unimplemented, read as '0'. Shaded cells are not used with the comparator voltage reference.

PIC18F85J90 FAMILY

NOTES:

22.0 SPECIAL FEATURES OF THE CPU

PIC18F85J90 family devices include several features intended to maximize reliability and minimize cost through elimination of external components. These are:

- Oscillator Selection
- Resets:
 - Power-on Reset (POR)
 - Power-up Timer (PWRT)
 - Oscillator Start-up Timer (OST)
 - Brown-out Reset (BOR)
- Interrupts
- Watchdog Timer (WDT)
- Fail-Safe Clock Monitor
- Two-Speed Start-up
- Code Protection
- In-Circuit Serial Programming

The oscillator can be configured for the application depending on frequency, power, accuracy and cost. All of the options are discussed in detail in **Section 2.0 “Oscillator Configurations”**.

A complete discussion of device Resets and interrupts is available in previous sections of this data sheet.

In addition to their Power-up and Oscillator Start-up Timers provided for Resets, the PIC18F85J90 family of devices have a configurable Watchdog Timer which is controlled in software.

The inclusion of an internal RC oscillator also provides the additional benefits of a Fail-Safe Clock Monitor (FSCM) and Two-Speed Start-up. FSCM provides for background monitoring of the peripheral clock and automatic switchover in the event of its failure. Two-Speed Start-up enables code to be executed almost immediately on start-up, while the primary clock source completes its start-up delays.

All of these features are enabled and configured by setting the appropriate Configuration register bits.

22.1 Configuration Bits

The Configuration bits can be programmed (read as ‘0’), or left unprogrammed (read as ‘1’), to select various device configurations. These bits are mapped starting at program memory location 300000h. A complete list is shown in Table 22-2. A detailed explanation of the various bit functions is provided in Register 22-1 through Register 22-5.

22.1.1 CONSIDERATIONS FOR CONFIGURING THE PIC18F85J90 FAMILY DEVICES

Devices of the PIC18F85J90 family do not use persistent memory registers to store configuration information. The configuration bytes are implemented as volatile memory which means that configuration data must be programmed each time the device is powered up.

Configuration data is stored in the four words at the top of the on-chip program memory space, known as the Flash Configuration Words. It is stored in program memory in the same order shown in Table 22-2, with CONFIG1L at the lowest address and CONFIG3H at the highest. The data is automatically loaded in the proper Configuration registers during device power-up.

When creating applications for these devices, users should always specifically allocate the location of the Flash Configuration Word for configuration data. This is to make certain that program code is not stored in this address when the code is compiled.

The volatile memory cells used for the Configuration bits always reset to ‘1’ on Power-on Resets. For all other types of Reset events, the previously programmed values are maintained and used without reloading from program memory.

The four Most Significant bits of CONFIG1H, CONFIG2H and CONFIG3H in program memory should also be ‘1111’. This makes these Configuration Words appear to be NOP instructions in the remote event that their locations are ever executed by accident. Since Configuration bits are not implemented in the corresponding locations, writing ‘1’s to these locations has no effect on device operation.

To prevent inadvertent configuration changes during code execution, all programmable Configuration bits are write-once. After a bit is initially programmed during a power cycle, it cannot be written to again. Changing a device configuration requires that power to the device be cycled.

TABLE 22-1: MAPPING OF THE FLASH CONFIGURATION WORDS TO THE CONFIGURATION REGISTERS

Configuration Byte	Code Space Address	Configuration Register Address
CONFIG1L	XXXF8h	300000h
CONFIG1H	XXXF9h	300001h
CONFIG2L	XXXFAh	300002h
CONFIG2H	XXXFBh	300003h
CONFIG3L	XXXFCh	300004h
CONFIG3H	XXXFDh	300005h

Legend: Unimplemented in PIC18F85J90 family devices.

PIC18F85J90 FAMILY

TABLE 22-2: CONFIGURATION BITS AND DEVICE IDs

File Name	Bit 7	Bit 6	Bit 5	Bit 4	Bit 3	Bit 2	Bit 1	Bit 0	Default/ Unprogrammed Value ⁽¹⁾	
300000h	CONFIG1L	$\overline{\text{DEBUG}}$	XINST	STVREN	—	—	—	—	WDTEN	111- -111
300001h	CONFIG1H	— ⁽²⁾	— ⁽²⁾	— ⁽²⁾	— ⁽²⁾	— ⁽³⁾	CP0	—	—	---- 01--
300002h	CONFIG2L	IESO	FCMEN	—	—	—	FOSC2	FOSC1	FOSC0	11-- -111
300003h	CONFIG2H	— ⁽²⁾	— ⁽²⁾	— ⁽²⁾	— ⁽²⁾	WDTPS3	WDTPS2	WDTPS1	WDTPS0	---- 1111
300005h	CONFIG3H	— ⁽²⁾	— ⁽²⁾	— ⁽²⁾	— ⁽²⁾	—	—	—	CCP2MX	---- ---1
3FFFFEh	DEVID1	DEV2	DEV1	DEV0	REV4	REV3	REV2	REV1	REV0	xxxx xxxx ⁽⁴⁾
3FFFFFh	DEVID2	DEV10	DEV9	DEV8	DEV7	DEV6	DEV5	DEV4	DEV3	0000 10x1 ⁽⁴⁾

Legend: x = unknown, - = unimplemented. Shaded cells are unimplemented, read as '0'.

Note 1: Values reflect the unprogrammed state as received from the factory and following Power-on Resets. In all other Reset states, the configuration bytes maintain their previously programmed states.

2: The value of these bits in program memory should always be '1'. This ensures that the location is executed as a NOP if it is accidentally executed.

3: This bit should always be maintained as '0'.

4: See Register 22-6 and Register 22-7 for DEVID values. These registers are read-only and cannot be programmed by the user.

PIC18F85J90 FAMILY

REGISTER 22-1: CONFIG1L: CONFIGURATION REGISTER 1 LOW (BYTE ADDRESS 300000h)

R/WO-1	R/WO-1	R/WO-1	U-0	U-0	U-0	U-0	R/WO-1
<u>DEBUG</u>	XINST	STVREN	—	—	—	—	WDTEN
bit 7							bit 0

Legend:

R = Readable bit WO = Write-Once bit U = Unimplemented bit, read as '0'
 -n = Value when device is unprogrammed '1' = Bit is set '0' = Bit is cleared

- bit 7 **DEBUG:** Background Debugger Enable bit
 1 = Background debugger disabled; RB6 and RB7 configured as general purpose I/O pins
 0 = Background debugger enabled; RB6 and RB7 are dedicated to In-Circuit Debug
- bit 6 **XINST:** Extended Instruction Set Enable bit
 1 = Instruction set extension and Indexed Addressing mode enabled
 0 = Instruction set extension and Indexed Addressing mode disabled (Legacy mode)
- bit 5 **STVREN:** Stack Overflow/Underflow Reset Enable bit
 1 = Reset on stack overflow/underflow enabled
 0 = Reset on stack overflow/underflow disabled
- bit 4-1 **Unimplemented:** Read as '0'
- bit 0 **WDTEN:** Watchdog Timer Enable bit
 1 = WDT enabled
 0 = WDT disabled (control is placed on SWDTEN bit)

REGISTER 22-2: CONFIG1H: CONFIGURATION REGISTER 1 HIGH (BYTE ADDRESS 300001h)

U-0	U-0	U-0	U-0	U-0	R/WO-1	U-0	U-0
—(1)	—(1)	—(1)	—(1)	—(2)	CP0	—	—
bit 7							bit 0

Legend:

R = Readable bit WO = Write-Once bit U = Unimplemented bit, read as '0'
 -n = Value when device is unprogrammed '1' = Bit is set '0' = Bit is cleared

- bit 7-3 **Unimplemented:** Read as '0'
- bit 2 **CP0:** Code Protection bit
 1 = Program memory is not code-protected
 0 = Program memory is code-protected
- bit 1-0 **Unimplemented:** Read as '0'

Note 1: The value of these bits in program memory should always be '1'. This ensures that the location is executed as a NOP if it is accidentally executed.

2: This bit should always be maintained as '0'.

PIC18F85J90 FAMILY

REGISTER 22-3: CONFIG2L: CONFIGURATION REGISTER 2 LOW (BYTE ADDRESS 300002h)

R/WO-1	R/WO-1	U-0	U-0	U-0	R/WO-1	R/WO-1	R/WO-1
IESO	FCMEN	—	—	—	FOSC2	FOSC1	FOSC0
bit 7							bit 0

Legend:

R = Readable bit	WO = Write-Once bit	U = Unimplemented bit, read as '0'
-n = Value when device is unprogrammed	'1' = Bit is set	'0' = Bit is cleared

- bit 7 **IESO:** Two-Speed Start-up (Internal/External Oscillator Switchover) Control bit
 1 = Two-Speed Start-up enabled
 0 = Two-Speed Start-up disabled
- bit 6 **FCMEN:** Fail-Safe Clock Monitor Enable bit
 1 = Fail-Safe Clock Monitor enabled
 0 = Fail-Safe Clock Monitor disabled
- bit 5-3 **Unimplemented:** Read as '0'
- bit 2-0 **FOSC2:FOSC0:** Oscillator Selection bits
 111 = OSC1/OSC2 as primary; EC oscillator with CLKO function and software controlled PLL (EC+PLL)
 110 = OSC1/OSC2 as primary; EC oscillator with CLKO function (EC)
 101 = OSC1/OSC2 as primary; HS oscillator with software controlled PLL (HS+PLL)
 100 = OSC1/OSC2 as primary; HS oscillator (HS)
 011 = INTOSC with CLKO as primary; port function on RA7; EC oscillator with CLKO function and software controlled PLL (EC+PLL)
 010 = INTOSC with CLKO as primary; port function on RA7; EC oscillator with CLKO function
 001 = INTOSC as primary with port function on RA6/RA7; HS oscillator with software controlled PLL (HS+PLL)
 000 = INTOSC as primary with port function on RA6/RA7; HS oscillator (HS)

PIC18F85J90 FAMILY

REGISTER 22-4: CONFIG2H: CONFIGURATION REGISTER 2 HIGH (BYTE ADDRESS 300003h)

U-0	U-0	U-0	U-0	R/WO-1	R/WO-1	R/WO-1	R/WO-1
—(1)	—(1)	—(1)	—(1)	WDTPS3	WDTPS2	WDTPS1	WDTPS0
bit 7							bit 0

Legend:

R = Readable bit WO = Write-Once bit U = Unimplemented bit, read as '0'
 -n = Value when device is unprogrammed '1' = Bit is set '0' = Bit is cleared

bit 7-4 **Unimplemented:** Read as '0'

bit 3-0 **WDTPS3:WDTPS0:** Watchdog Timer Postscale Select bits

1111 = 1:32,768
 1110 = 1:16,384
 1101 = 1:8,192
 1100 = 1:4,096
 1011 = 1:2,048
 1010 = 1:1,024
 1001 = 1:512
 1000 = 1:256
 0111 = 1:128
 0110 = 1:64
 0101 = 1:32
 0100 = 1:16
 0011 = 1:8
 0010 = 1:4
 0001 = 1:2
 0000 = 1:1

Note 1: The value of these bits in program memory should always be '1'. This ensures that the location is executed as a NOP if it is accidentally executed.

REGISTER 22-5: CONFIG3H: CONFIGURATION REGISTER 3 HIGH (BYTE ADDRESS 300005h)

U-0	U-0	U-0	U-0	U-0	U-0	U-0	R/WO-1
—(1)	—(1)	—(1)	—(1)	—	—	—	CCP2MX
bit 7							bit 0

Legend:

R = Readable bit WO = Write-Once bit U = Unimplemented bit, read as '0'
 -n = Value when device is unprogrammed '1' = Bit is set '0' = Bit is cleared

bit 7-1 **Unimplemented:** Read as '0'

bit 0 **CCP2MX:** CCP2 MUX bit

1 = CCP2 is multiplexed with RC1
 0 = CCP2 is multiplexed with RE7

Note 1: The value of these bits in program memory should always be '1'. This ensures that the location is executed as a NOP if it is accidentally executed.

PIC18F85J90 FAMILY

REGISTER 22-6: DEVID1: DEVICE ID REGISTER 1 FOR PIC18F85J90 FAMILY DEVICES

R	R	R	R	R	R	R	R
DEV2	DEV1	DEV0	REV4	REV3	REV2	REV1	REV0
bit 7							bit 0

Legend:

R = Read-only bit

bit 7-5 **DEV2:DEV0:** Device ID bits

111 = PIC18F85J90

101 = PIC18F84J90

100 = PIC18F83J90

011 = PIC18F65J90

001 = PIC18F64J90

000 = PIC18F63J90

bit 4-0 **REV4:REV0:** Revision ID bits

These bits are used to indicate the device revision.

REGISTER 22-7: DEVID2: DEVICE ID REGISTER 2 FOR PIC18F85J90 FAMILY DEVICES

R	R	R	R	R	R	R	R
DEV10 ⁽¹⁾	DEV9 ⁽¹⁾	DEV8 ⁽¹⁾	DEV7 ⁽¹⁾	DEV6 ⁽¹⁾	DEV5 ⁽¹⁾	DEV4 ⁽¹⁾	DEV3 ⁽¹⁾
bit 7							bit 0

Legend:

R = Read-only bit

bit 7-0 **DEV10:DEV3:** Device ID bits⁽¹⁾

These bits are used with the DEV2:DEV0 bits in the Device ID Register 1 to identify the part number.

0011 1000 = PIC18F6XJ90/8XJ90 devices

Note 1: The values for DEV10:DEV3 may be shared with other device families. The specific device is always identified by using the entire DEV10:DEV0 bit sequence.

PIC18F85J90 FAMILY

22.2 Watchdog Timer (WDT)

For PIC18F85J90 family devices, the WDT is driven by the INTRC oscillator. When the WDT is enabled, the clock source is also enabled. The nominal WDT period is 4 ms and has the same stability as the INTRC oscillator.

The 4 ms period of the WDT is multiplied by a 16-bit postscaler. Any output of the WDT postscaler is selected by a multiplexor, controlled by the WDTPS bits in Configuration Register 2H. Available periods range from 4 ms to 131.072 seconds (2.18 minutes). The WDT and postscaler are cleared whenever a SLEEP or CLRWDT instruction is executed, or a clock failure (primary or Timer1 oscillator) has occurred.

Note 1: The CLRWDT and SLEEP instructions clear the WDT and postscaler counts when executed.

2: When a CLRWDT instruction is executed, the postscaler count will be cleared.

22.2.1 CONTROL REGISTER

The WDTCON register (Register 22-8) is a readable and writable register. The SWDTEN bit enables or disables WDT operation. This allows software to override the WDTE Configuration bit and enable the WDT only if it has been disabled by the Configuration bit.

FIGURE 22-1: WDT BLOCK DIAGRAM

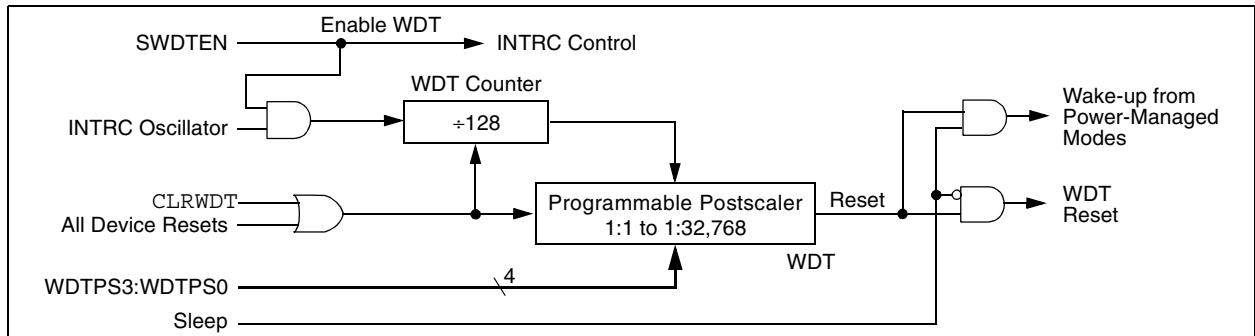

REGISTER 22-8: WDTCON: WATCHDOG TIMER CONTROL REGISTER

R/W-0	U-0	U-0	U-0	U-0	U-0	U-0	R/W-0
REGSLP ⁽¹⁾	—	—	—	—	—	—	SWDTEN ⁽²⁾
bit 7							bit 0

Legend:

R = Readable bit W = Writable bit U = Unimplemented bit, read as '0'
 -n = Value at POR '1' = Bit is set '0' = Bit is cleared x = Bit is unknown

- bit 7 **REGSLP:** Voltage Regulator Low-Power Operation Enable bit⁽¹⁾
 1 = On-chip regulator enters low-power operation when device enters Sleep mode
 0 = On-chip regulator continues to operate normally in Sleep mode
- bit 6-1 **Unimplemented:** Read as '0'
- bit 0 **SWDTEN:** Software Controlled Watchdog Timer Enable bit⁽²⁾
 1 = Watchdog Timer is on
 0 = Watchdog Timer is off

Note 1: The REGSLP bit is automatically cleared when a Low-Voltage Detect condition occurs.
2: This bit has no effect if the Configuration bit, WDTE, is enabled.

TABLE 22-3: SUMMARY OF WATCHDOG TIMER REGISTERS

Name	Bit 7	Bit 6	Bit 5	Bit 4	Bit 3	Bit 2	Bit 1	Bit 0	Reset Values on page
RCON	IPEN	—	—	\overline{RI}	\overline{TO}	PD	\overline{POR}	BOR	52
WDTCON	REGSLP	—	—	—	—	—	—	SWDTEN	52

Legend: — = unimplemented, read as '0'. Shaded cells are not used by the Watchdog Timer.

PIC18F85J90 FAMILY

22.3 On-Chip Voltage Regulator

All of the PIC18F85J90 family devices power their core digital logic at a nominal 2.5V. For designs that are required to operate at a higher typical voltage, such as 3.3V, all devices in the PIC18F85J90 family incorporate an on-chip regulator that allows the device to run its core logic from VDD.

The regulator is controlled by the ENVREG pin. Tying VDD to the pin enables the regulator, which in turn, provides power to the core from the other VDD pins. When the regulator is enabled, a low-ESR filter capacitor must be connected to the VDDCORE/VCAP pin (Figure 22-2). This helps to maintain the stability of the regulator. The recommended value for the filter capacitor is provided in **Section 25.3 “DC Characteristics: PIC18F84J90 Family (Industrial)”**.

If ENVREG is tied to VSS, the regulator is disabled. In this case, separate power for the core logic at a nominal 2.5V must be supplied to the device on the VDDCORE/VCAP pin to run the I/O pins at higher voltage levels, typically 3.3V. Alternatively, the VDDCORE/VCAP and VDD pins can be tied together to operate at a lower nominal voltage. Refer to Figure 22-2 for possible configurations.

22.3.1 VOLTAGE REGULATION AND LOW VOLTAGE DETECTION

When it is enabled, the on-chip regulator provides a constant voltage of 2.5V nominal to the digital core logic. The regulator can provide this level from a Vdd of about 2.5V, all the way up to the device's Vddmax. It does not have the capability to boost Vdd levels below 2.5V.

In order to prevent “brown-out” conditions, when the voltage drops too low for the regulator, the regulator enters Tracking mode. In Tracking mode, the regulator output follows VDD, with a typical voltage drop of 100 mV.

The on-chip regulator includes a simple Low-Voltage Detect (LVD) circuit. If Vdd drops too low to maintain approximately 2.45V on Vddcore, the circuit sets the Low-Voltage Detect Interrupt Flag, LVDIF (PIR2<2>) and clears the REGSLP (WDTCON<7>) bit, if it was set.

This can be used to generate an interrupt and put the application into a low-power operational mode, or trigger an orderly shutdown. Low-Voltage Detection is only available when the regulator is enabled.

FIGURE 22-2: CONNECTIONS FOR THE ON-CHIP REGULATOR

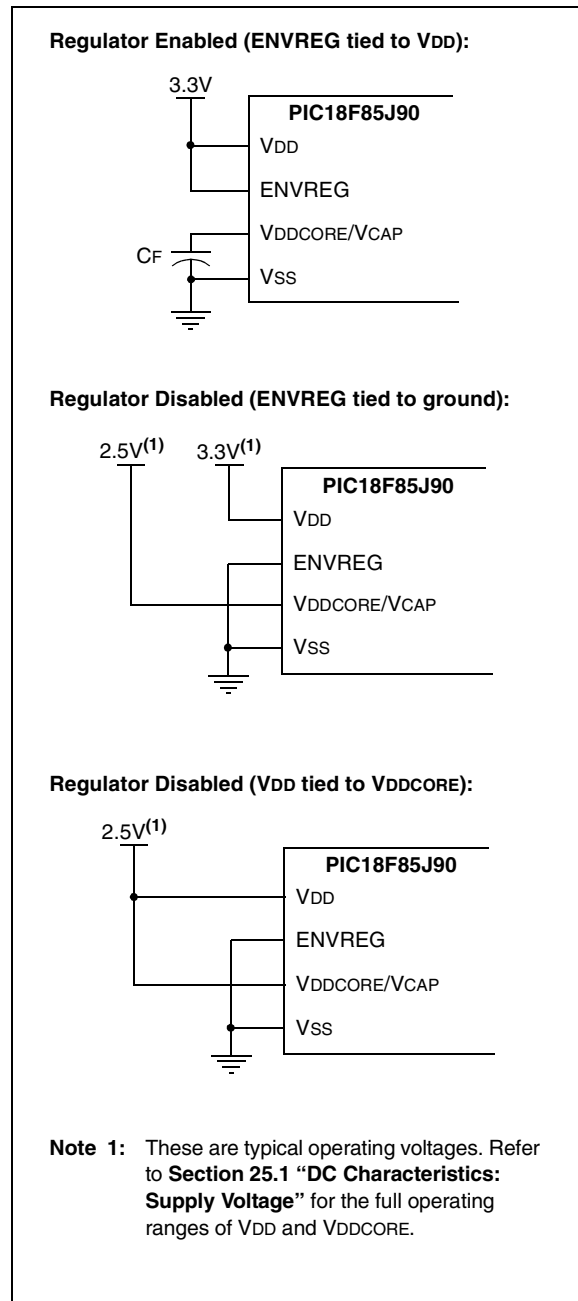

22.3.2 ON-CHIP REGULATOR AND BOR

When the on-chip regulator is enabled, PIC18F85J90 family devices also have a simple Brown-out Reset capability. If the voltage supplied to the regulator falls to a level that is inadequate to maintain a regulated output for full-speed operation, the regulator Reset circuitry will generate a Brown-out Reset. This event is captured by the BOR flag bit (RCON<0>).

The operation of the BOR is described in more detail in **Section 4.4 “Brown-out Reset (BOR)”** and **Section 4.4.1 “Detecting BOR”**.

22.3.3 POWER-UP REQUIREMENTS

The on-chip regulator is designed to meet the power-up requirements for the device. If the application does not use the regulator, then strict power-up conditions must be adhered to. While powering up, VDDCORE must never exceed VDD by 0.3 volts.

22.3.4 OPERATION IN SLEEP MODE

When enabled, the on-chip regulator always consumes a small incremental amount of current over IDD. This includes when the device is in Sleep mode, even though the core digital logic does not require power. To provide additional savings in applications where power resources are critical, the regulator can be configured to automatically disable itself whenever the device goes into Sleep mode. This feature is controlled by the REGSLP bit (WDTCON<7>). Setting this bit disables the regulator in Sleep mode, and reduces its current consumption to a minimum.

Substantial Sleep mode power savings can be obtained by setting the REGSLP bit, but device wake-up time will increase in order to ensure the regulator has enough time to stabilize.

The REGSLP bit is automatically cleared by hardware when a Low-Voltage Detect condition occurs. The REGSLP bit can be set again in software, which would continue to keep the voltage regulator in Low-Power mode. This, however, is not recommended if any write operations to the Flash will be performed.

22.4 Two-Speed Start-up

The Two-Speed Start-up feature helps to minimize the latency period, from oscillator start-up to code execution, by allowing the microcontroller to use the INTRC oscillator as a clock source until the primary clock source is available. It is enabled by setting the IESO Configuration bit.

Two-Speed Start-up should be enabled only if the primary oscillator mode is HS or HSPLL (Crystal-Based) modes. Since the EC and ECPLL modes do not require an OST start-up delay, Two-Speed Start-up should be disabled.

When enabled, Resets and wake-ups from Sleep mode cause the device to configure itself to run from the internal oscillator block as the clock source, following the time-out of the Power-up Timer after a Power-on Reset is enabled. This allows almost immediate code execution while the primary oscillator starts and the OST is running. Once the OST times out, the device automatically switches to PRI_RUN mode.

In all other power-managed modes, Two-Speed Start-up is not used. The device will be clocked by the currently selected clock source until the primary clock source becomes available. The setting of the IESO bit is ignored.

FIGURE 22-3: TIMING TRANSITION FOR TWO-SPEED START-UP (INTRC TO HSPLL)

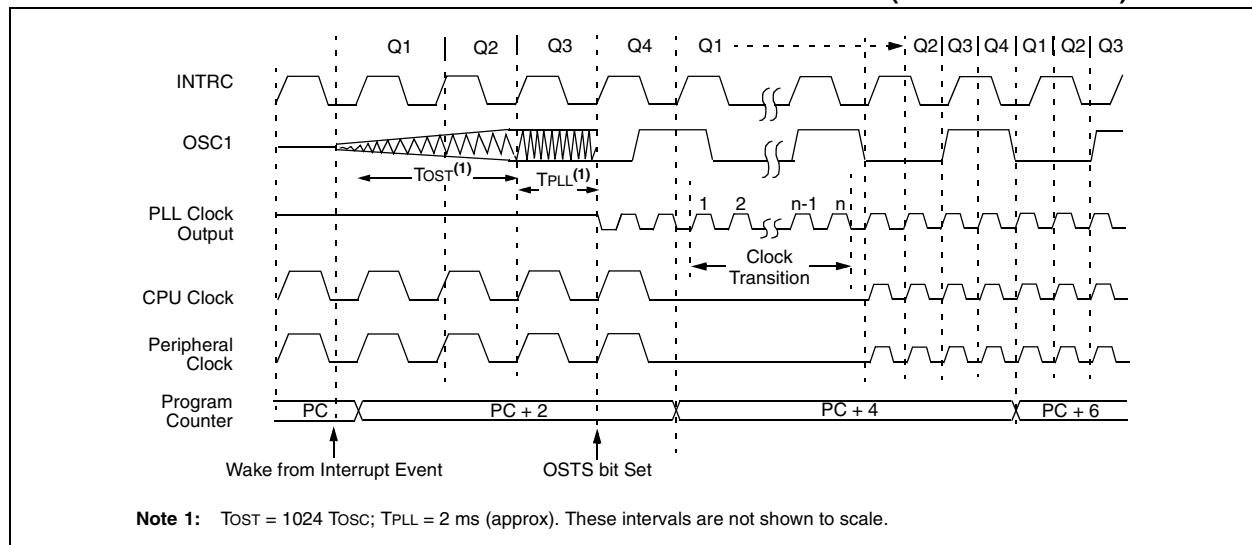

PIC18F85J90 FAMILY

22.4.1 SPECIAL CONSIDERATIONS FOR USING TWO-SPEED START-UP

While using the INTRC oscillator in Two-Speed Start-up, the device still obeys the normal command sequences for entering power-managed modes, including serial `SLEEP` instructions (refer to **Section 3.1.4 “Multiple Sleep Commands”**). In practice, this means that user code can change the `SCS1:SCS0` bit settings or issue `SLEEP` instructions before the OST times out. This would allow an application to briefly wake-up, perform routine “housekeeping” tasks and return to Sleep before the device starts to operate from the primary oscillator.

User code can also check if the primary clock source is currently providing the device clocking by checking the status of the OSTS bit (`OSCCON<3>`). If the bit is set, the primary oscillator is providing the clock. Otherwise, the internal oscillator block is providing the clock during wake-up from Reset or Sleep mode.

22.5 Fail-Safe Clock Monitor

The Fail-Safe Clock Monitor (FSCM) allows the microcontroller to continue operation in the event of an external oscillator failure by automatically switching the device clock to the internal oscillator block. The FSCM function is enabled by setting the `FCMEN` Configuration bit.

When FSCM is enabled, the INTRC oscillator runs at all times to monitor clocks to peripherals and provides a backup clock in the event of a clock failure. Clock monitoring (shown in Figure 22-4) is accomplished by creating a sample clock signal which is the INTRC output divided by 64. This allows ample time between FSCM sample clocks for a peripheral clock edge to occur. The peripheral device clock and the sample clock are presented as inputs to the Clock Monitor latch (CM). The CM is set on the falling edge of the device clock source but cleared on the rising edge of the sample clock.

FIGURE 22-4: FSCM BLOCK DIAGRAM

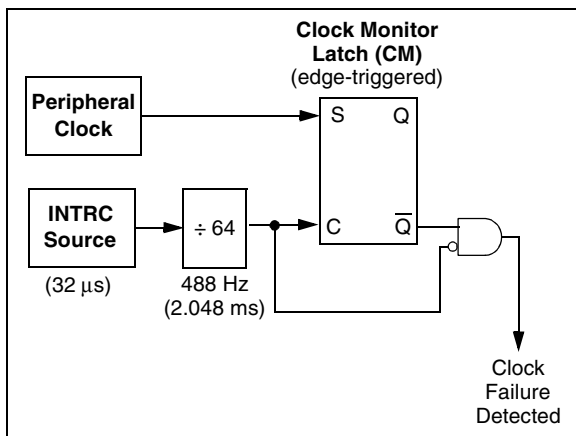

Clock failure is tested for on the falling edge of the sample clock. If a sample clock falling edge occurs while `CM` is still set, a clock failure has been detected (Figure 22-5). This causes the following:

- the FSCM generates an oscillator fail interrupt by setting bit, `OSCFIF (PIR2<7>)`;
- the device clock source is switched to the internal oscillator block (`OSCCON` is not updated to show the current clock source – this is the fail-safe condition); and
- the WDT is reset.

During switchover, the postscaler frequency from the internal oscillator block may not be sufficiently stable for timing sensitive applications. In these cases, it may be desirable to select another clock configuration and enter an alternate power-managed mode. This can be done to attempt a partial recovery or execute a controlled shutdown. See **Section 3.1.4 “Multiple Sleep Commands”** and **Section 22.4.1 “Special Considerations for Using Two-Speed Start-up”** for more details.

The FSCM will detect failures of the primary or secondary clock sources only. If the internal oscillator block fails, no failure would be detected, nor would any action be possible.

22.5.1 FSCM AND THE WATCHDOG TIMER

Both the FSCM and the WDT are clocked by the INTRC oscillator. Since the WDT operates with a separate divider and counter, disabling the WDT has no effect on the operation of the INTRC oscillator when the FSCM is enabled.

As already noted, the clock source is switched to the INTRC clock when a clock failure is detected; this may mean a substantial change in the speed of code execution. If the WDT is enabled with a small prescale value, a decrease in clock speed allows a WDT time-out to occur and a subsequent device Reset. For this reason, Fail-Safe Clock Monitor events also reset the WDT and postscaler, allowing it to start timing from when execution speed was changed and decreasing the likelihood of an erroneous time-out.

If the interrupt is disabled, subsequent interrupts while in Idle mode will cause the CPU to begin executing instructions while being clocked by the INTRC source.

FIGURE 22-5: FSCM TIMING DIAGRAM

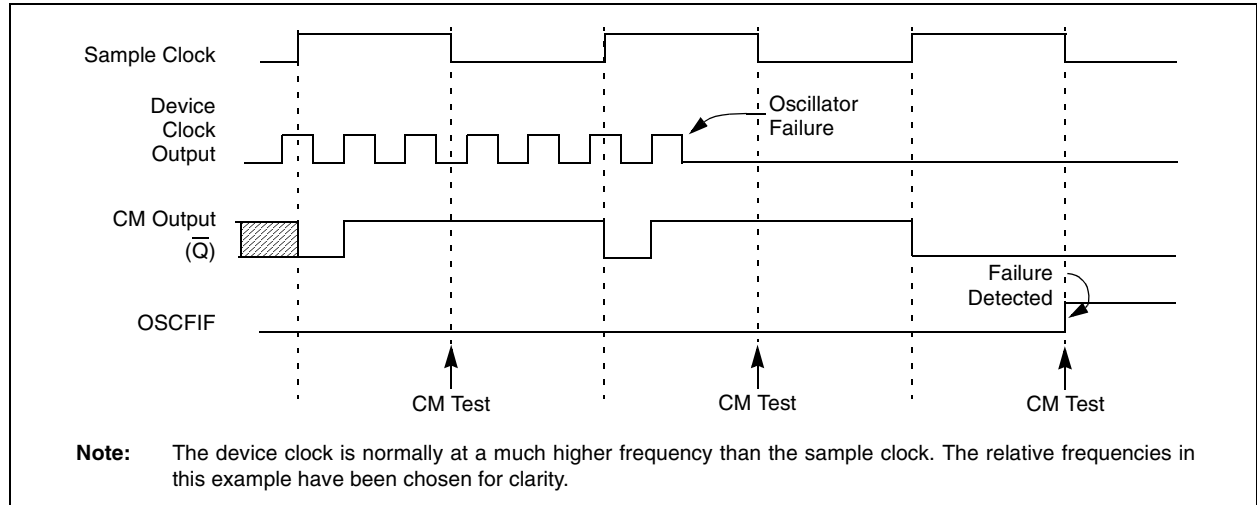

22.5.2 EXITING FAIL-SAFE OPERATION

The fail-safe condition is terminated by either a device Reset or by entering a power-managed mode. On Reset, the controller starts the primary clock source specified in Configuration Register 2H (with any required start-up delays that are required for the oscillator mode, such as OST or PLL timer). The INTRC oscillator provides the device clock until the primary clock source becomes ready (similar to a Two-Speed Start-up). The clock source is then switched to the primary clock (indicated by the OSTS bit in the OSCCON register becoming set). The Fail-Safe Clock Monitor then resumes monitoring the peripheral clock.

The primary clock source may never become ready during start-up. In this case, operation is clocked by the INTOSC multiplexor. The OSCCON register will remain in its Reset state until a power-managed mode is entered.

22.5.3 FSCM INTERRUPTS IN POWER-MANAGED MODES

By entering a power-managed mode, the clock multiplexor selects the clock source selected by the OSCCON register. Fail-Safe Clock Monitoring of the power-managed clock source resumes in the power-managed mode.

If an oscillator failure occurs during power-managed operation, the subsequent events depend on whether or not the oscillator failure interrupt is enabled. If enabled ($OSCFIF = 1$), code execution will be clocked by the INTRC multiplexor. An automatic transition back to the failed clock source will not occur.

22.5.4 POR OR WAKE-UP FROM SLEEP

The FSCM is designed to detect oscillator failure at any point after the device has exited Power-on Reset (POR) or low-power Sleep mode. When the primary device clock is either EC or INTRC mode, monitoring can begin immediately following these events.

For HS or HSPLL modes, the situation is somewhat different. Since the oscillator may require a start-up time considerably longer than the FSCM sample clock time, a false clock failure may be detected. To prevent this, the internal oscillator block is automatically configured as the device clock and functions until the primary clock is stable (the OST and PLL timers have timed out). This is identical to Two-Speed Start-up mode. Once the primary clock is stable, the INTRC returns to its role as the FSCM source.

Note: The same logic that prevents false oscillator failure interrupts on POR, or wake from Sleep, will also prevent the detection of the oscillator's failure to start at all following these events. This can be avoided by monitoring the OSTS bit and using a timing routine to determine if the oscillator is taking too long to start. Even so, no oscillator failure interrupt will be flagged.

As noted in **Section 22.4.1 "Special Considerations for Using Two-Speed Start-up"**, it is also possible to select another clock configuration and enter an alternate power-managed mode while waiting for the primary clock to become stable. When the new power-managed mode is selected, the primary clock is disabled.

PIC18F85J90 FAMILY

22.6 Program Verification and Code Protection

For all devices in the PIC18F85J90 family of devices, the on-chip program memory space is treated as a single block. Code protection for this block is controlled by one Configuration bit, CP0. This bit inhibits external reads and writes to the program memory space. It has no direct effect in normal execution mode.

22.6.1 CONFIGURATION REGISTER PROTECTION

The Configuration registers are protected against untoward changes or reads in two ways. The primary protection is the write-once feature of the Configuration bits which prevents reconfiguration once the bit has been programmed during a power cycle. To safeguard against unpredictable events, Configuration bit changes resulting from individual cell-level disruptions (such as ESD events) will cause a parity error and trigger a device Reset.

The data for the Configuration registers is derived from the Flash Configuration Words in program memory. When the CP0 bit set, the source data for device configuration is also protected as a consequence.

22.7 In-Circuit Serial Programming

PIC18F85J90 family microcontrollers can be serially programmed while in the end application circuit. This is simply done with two lines for clock and data and three other lines for power, ground and the programming voltage. This allows customers to manufacture boards with unprogrammed devices and then program the microcontroller just before shipping the product. This also allows the most recent firmware or a custom firmware to be programmed.

22.8 In-Circuit Debugger

When the $\overline{\text{DEBUG}}$ Configuration bit is programmed to a '0', the In-Circuit Debugger functionality is enabled. This function allows simple debugging functions when used with MPLAB[®] IDE. When the microcontroller has this feature enabled, some resources are not available for general use. Table 22-4 shows which resources are required by the background debugger.

TABLE 22-4: DEBUGGER RESOURCES

I/O pins:	RB6, RB7
Stack:	2 levels
Program Memory:	512 bytes
Data Memory:	10 bytes

23.0 INSTRUCTION SET SUMMARY

The PIC18F85J90 family of devices incorporate the standard set of 75 PIC18 core instructions, as well as an extended set of 8 new instructions for the optimization of code that is recursive or that utilizes a software stack. The extended set is discussed later in this section.

23.1 Standard Instruction Set

The standard PIC18 instruction set adds many enhancements to the previous PIC[®] MCU instruction sets, while maintaining an easy migration from these PIC MCU instruction sets. Most instructions are a single program memory word (16 bits), but there are four instructions that require two program memory locations.

Each single-word instruction is a 16-bit word divided into an opcode, which specifies the instruction type and one or more operands, which further specify the operation of the instruction.

The instruction set is highly orthogonal and is grouped into four basic categories:

- **Byte-oriented** operations
- **Bit-oriented** operations
- **Literal** operations
- **Control** operations

The PIC18 instruction set summary in Table 23-2 lists **byte-oriented**, **bit-oriented**, **literal** and **control** operations. Table 23-1 shows the opcode field descriptions.

Most **byte-oriented** instructions have three operands:

1. The file register (specified by 'f')
2. The destination of the result (specified by 'd')
3. The accessed memory (specified by 'a')

The file register designator 'f' specifies which file register is to be used by the instruction. The destination designator 'd' specifies where the result of the operation is to be placed. If 'd' is zero, the result is placed in the WREG register. If 'd' is one, the result is placed in the file register specified in the instruction.

All **bit-oriented** instructions have three operands:

1. The file register (specified by 'f')
2. The bit in the file register (specified by 'b')
3. The accessed memory (specified by 'a')

The bit field designator 'b' selects the number of the bit affected by the operation, while the file register designator 'f' represents the number of the file in which the bit is located.

The **literal** instructions may use some of the following operands:

- A literal value to be loaded into a file register (specified by 'k')
- The desired FSR register to load the literal value into (specified by 'f')
- No operand required (specified by '—')

The **control** instructions may use some of the following operands:

- A program memory address (specified by 'n')
- The mode of the CALL or RETURN instructions (specified by 's')
- The mode of the table read and table write instructions (specified by 'm')
- No operand required (specified by '—')

All instructions are a single word, except for four double-word instructions. These instructions were made double-word to contain the required information in 32 bits. In the second word, the 4 MSBs are '1's. If this second word is executed as an instruction (by itself), it will execute as a NOP.

All single-word instructions are executed in a single instruction cycle, unless a conditional test is true or the program counter is changed as a result of the instruction. In these cases, the execution takes two instruction cycles with the additional instruction cycle(s) executed as a NOP.

The double-word instructions execute in two instruction cycles.

One instruction cycle consists of four oscillator periods. Thus, for an oscillator frequency of 4 MHz, the normal instruction execution time is 1 μ s. If a conditional test is true, or the program counter is changed as a result of an instruction, the instruction execution time is 2 μ s. Two-word branch instructions (if true) would take 3 μ s.

Figure 23-1 shows the general formats that the instructions can have. All examples use the convention 'nnh' to represent a hexadecimal number.

The Instruction Set Summary, shown in Table 23-2, lists the standard instructions recognized by the Microchip MPASM[™] Assembler.

Section 23.1.1 "Standard Instruction Set" provides a description of each instruction.

PIC18F85J90 FAMILY

TABLE 23-1: OPCODE FIELD DESCRIPTIONS

Field	Description
a	RAM access bit: a = 0: RAM location in Access RAM (BSR register is ignored) a = 1: RAM bank is specified by BSR register
bbb	Bit address within an 8-bit file register (0 to 7).
BSR	Bank Select Register. Used to select the current RAM bank.
C, DC, Z, OV, N	ALU Status bits: C arry, D igit C arry, Z ero, O verflow, N egative.
d	Destination select bit: d = 0: store result in WREG d = 1: store result in file register f
dest	Destination: either the WREG register or the specified register file location.
f	8-bit Register file address (00h to FFh), or 2-bit FSR designator (0h to 3h).
f _s	12-bit Register file address (000h to FFFh). This is the source address.
f _d	12-bit Register file address (000h to FFFh). This is the destination address.
GIE	Global Interrupt Enable bit.
k	Literal field, constant data or label (may be either an 8-bit, 12-bit or a 20-bit value).
label	Label name.
mm	The mode of the TBLPTR register for the table read and table write instructions. Only used with table read and table write instructions:
*	No Change to register (such as TBLPTR with table reads and writes)
*+	Post-Increment register (such as TBLPTR with table reads and writes)
*-	Post-Decrement register (such as TBLPTR with table reads and writes)
+*	Pre-Increment register (such as TBLPTR with table reads and writes)
n	The relative address (2's complement number) for relative branch instructions or the direct address for Call/Branch and Return instructions.
PC	Program Counter.
PCL	Program Counter Low Byte.
PCH	Program Counter High Byte.
PCLATH	Program Counter High Byte Latch.
PCLATU	Program Counter Upper Byte Latch.
PD	Power-Down bit.
PRODH	Product of Multiply High Byte.
PRODL	Product of Multiply Low Byte.
s	Fast Call/Return mode select bit: s = 0: do not update into/from shadow registers s = 1: certain registers loaded into/from shadow registers (Fast mode)
TBLPTR	21-bit Table Pointer (points to a Program Memory location).
TABLAT	8-bit Table Latch.
TO	Time-out bit.
TOS	Top-of-Stack.
u	Unused or Unchanged.
WDT	Watchdog Timer.
WREG	Working register (accumulator).
x	Don't care ('0' or '1'). The assembler will generate code with x = 0. It is the recommended form of use for compatibility with all Microchip software tools.
z _s	7-bit offset value for Indirect Addressing of register files (source).
z _d	7-bit offset value for Indirect Addressing of register files (destination).
{ }	Optional argument.
[text]	Indicates an Indexed Address.
(text)	The contents of text.
[expr] <n>	Specifies bit n of the register indicated by the pointer expr.
→	Assigned to.
< >	Register bit field.
∈	In the set of.
<i>italics</i>	User-defined term (font is Courier).

FIGURE 23-1: GENERAL FORMAT FOR INSTRUCTIONS

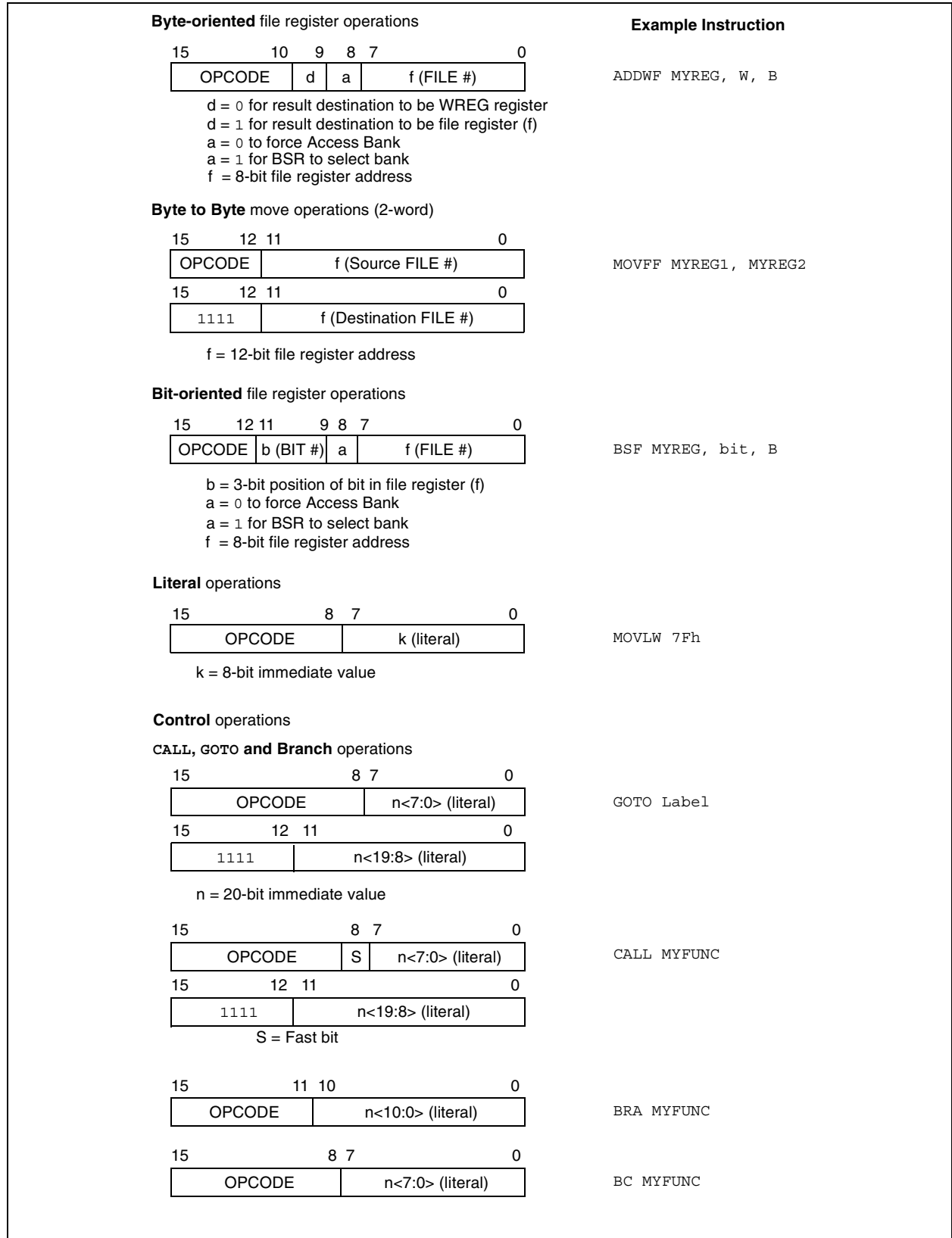

PIC18F85J90 FAMILY

TABLE 23-2: PIC18F85J90 FAMILY INSTRUCTION SET

Mnemonic, Operands	Description	Cycles	16-bit Instruction Word				Status Affected	Notes	
			MSb			LSb			
BYTE-ORIENTED OPERATIONS									
ADDWF	f, d, a	Add WREG and f	1	0010	01da	ffff	ffff	C, DC, Z, OV, N	1, 2
ADDWFC	f, d, a	Add WREG and Carry bit to f	1	0010	00da	ffff	ffff	C, DC, Z, OV, N	1, 2
ANDWF	f, d, a	AND WREG with f	1	0001	01da	ffff	ffff	Z, N	1, 2
CLRF	f, a	Clear f	1	0110	101a	ffff	ffff	Z	2
COMF	f, d, a	Complement f	1	0001	11da	ffff	ffff	Z, N	1, 2
CPFSEQ	f, a	Compare f with WREG, skip =	1 (2 or 3)	0110	001a	ffff	ffff	None	4
CPFSGT	f, a	Compare f with WREG, skip >	1 (2 or 3)	0110	010a	ffff	ffff	None	4
CPFSLT	f, a	Compare f with WREG, skip <	1 (2 or 3)	0110	000a	ffff	ffff	None	1, 2
DECf	f, d, a	Decrement f	1	0000	01da	ffff	ffff	C, DC, Z, OV, N	1, 2, 3, 4
DECFSZ	f, d, a	Decrement f, Skip if 0	1 (2 or 3)	0010	11da	ffff	ffff	None	1, 2, 3, 4
DCFSNZ	f, d, a	Decrement f, Skip if Not 0	1 (2 or 3)	0100	11da	ffff	ffff	None	1, 2
INCF	f, d, a	Increment f	1	0010	10da	ffff	ffff	C, DC, Z, OV, N	1, 2, 3, 4
INCFSZ	f, d, a	Increment f, Skip if 0	1 (2 or 3)	0011	11da	ffff	ffff	None	4
INFSNZ	f, d, a	Increment f, Skip if Not 0	1 (2 or 3)	0100	10da	ffff	ffff	None	1, 2
IORWF	f, d, a	Inclusive OR WREG with f	1	0001	00da	ffff	ffff	Z, N	1, 2
MOVF	f, d, a	Move f	1	0101	00da	ffff	ffff	Z, N	1
MOVFF	f _s , f _d	Move f _s (source) to f _d (destination)	2	1100	ffff	ffff	ffff	None	
MOVWF	f, a	Move WREG to f	1	0110	111a	ffff	ffff	None	
MULWF	f, a	Multiply WREG with f	1	0000	001a	ffff	ffff	None	1, 2
NEGF	f, a	Negate f	1	0110	110a	ffff	ffff	C, DC, Z, OV, N	
RLCF	f, d, a	Rotate Left f through Carry	1	0011	01da	ffff	ffff	C, Z, N	1, 2
RLNCF	f, d, a	Rotate Left f (No Carry)	1	0100	01da	ffff	ffff	Z, N	
RRCF	f, d, a	Rotate Right f through Carry	1	0011	00da	ffff	ffff	C, Z, N	
RRNCF	f, d, a	Rotate Right f (No Carry)	1	0100	00da	ffff	ffff	Z, N	
SETF	f, a	Set f	1	0110	100a	ffff	ffff	None	1, 2
SUBFWB	f, d, a	Subtract f from WREG with borrow	1	0101	01da	ffff	ffff	C, DC, Z, OV, N	
SUBWF	f, d, a	Subtract WREG from f	1	0101	11da	ffff	ffff	C, DC, Z, OV, N	1, 2
SUBWFB	f, d, a	Subtract WREG from f with borrow	1	0101	10da	ffff	ffff	C, DC, Z, OV, N	
SWAPF	f, d, a	Swap nibbles in f	1	0011	10da	ffff	ffff	None	4
TSTFSZ	f, a	Test f, skip if 0	1 (2 or 3)	0110	011a	ffff	ffff	None	1, 2
XORWF	f, d, a	Exclusive OR WREG with f	1	0001	10da	ffff	ffff	Z, N	

Note 1: When a PORT register is modified as a function of itself (e.g., `MOVF PORTB, 1, 0`), the value used will be that value present on the pins themselves. For example, if the data latch is '1' for a pin configured as input and is driven low by an external device, the data will be written back with a '0'.

- If this instruction is executed on the TMR0 register (and, where applicable, d = 1), the prescaler will be cleared if assigned.
- If Program Counter (PC) is modified or a conditional test is true, the instruction requires two cycles. The second cycle is executed as a NOP.
- Some instructions are two-word instructions. The second word of these instructions will be executed as a NOP unless the first word of the instruction retrieves the information embedded in these 16-bits. This ensures that all program memory locations have a valid instruction.

PIC18F85J90 FAMILY

TABLE 23-2: PIC18F85J90 FAMILY INSTRUCTION SET (CONTINUED)

Mnemonic, Operands	Description	Cycles	16-bit Instruction Word				Status Affected	Notes	
			MSb			LSb			
BIT-ORIENTED OPERATIONS									
BCF	f, b, a	Bit Clear f	1	1001	bbba	ffff	ffff	None	1, 2
BSF	f, b, a	Bit Set f	1	1000	bbba	ffff	ffff	None	1, 2
BTFSC	f, b, a	Bit Test f, Skip if Clear	1 (2 or 3)	1011	bbba	ffff	ffff	None	3, 4
BTFSS	f, b, a	Bit Test f, Skip if Set	1 (2 or 3)	1010	bbba	ffff	ffff	None	3, 4
BTG	f, b, a	Bit Toggle f	1	0111	bbba	ffff	ffff	None	1, 2
CONTROL OPERATIONS									
BC	n	Branch if Carry	1 (2)	1110	0010	nnnn	nnnn	None	4
BN	n	Branch if Negative	1 (2)	1110	0110	nnnn	nnnn	None	
BNC	n	Branch if Not Carry	1 (2)	1110	0011	nnnn	nnnn	None	
BNN	n	Branch if Not Negative	1 (2)	1110	0111	nnnn	nnnn	None	
BNOV	n	Branch if Not Overflow	1 (2)	1110	0101	nnnn	nnnn	None	
BNZ	n	Branch if Not Zero	1 (2)	1110	0001	nnnn	nnnn	None	
BOV	n	Branch if Overflow	1 (2)	1110	0100	nnnn	nnnn	None	
BRA	n	Branch Unconditionally	2	1101	0nnn	nnnn	nnnn	None	
BZ	n	Branch if Zero	1 (2)	1110	0000	nnnn	nnnn	None	
CALL	n, s	Call subroutine	2	1110	110s	kkkk	kkkk	None	
		1st word							
		2nd word		1111	kkkk	kkkk	kkkk		
CLRWDT	—	Clear Watchdog Timer	1	0000	0000	0000	0100	$\overline{\text{TO}}$, $\overline{\text{PD}}$	
DAW	—	Decimal Adjust WREG	1	0000	0000	0000	0111	C	
GOTO	n	Go to address	2	1110	1111	kkkk	kkkk	None	
		1st word							
		2nd word		1111	kkkk	kkkk	kkkk		
NOP	—	No Operation	1	0000	0000	0000	0000	None	
NOP	—	No Operation	1	1111	xxxx	xxxx	xxxx	None	
POP	—	Pop top of return stack (TOS)	1	0000	0000	0000	0110	None	
PUSH	—	Push top of return stack (TOS)	1	0000	0000	0000	0101	None	
RCALL	n	Relative Call	2	1101	1nnn	nnnn	nnnn	None	
RESET		Software device Reset	1	0000	0000	1111	1111	All	
RETFIE	s	Return from interrupt enable	2	0000	0000	0001	000s	GIE/GIEH, PEIE/GIEL	
RETLW	k	Return with literal in WREG	2	0000	1100	kkkk	kkkk	None	
RETURN	s	Return from Subroutine	2	0000	0000	0001	001s	None	
SLEEP	—	Go into Standby mode	1	0000	0000	0000	0011	$\overline{\text{TO}}$, $\overline{\text{PD}}$	

Note 1: When a PORT register is modified as a function of itself (e.g., MOVF PORTB, 1, 0), the value used will be that value present on the pins themselves. For example, if the data latch is '1' for a pin configured as input and is driven low by an external device, the data will be written back with a '0'.

- 2:** If this instruction is executed on the TMR0 register (and, where applicable, d = 1), the prescaler will be cleared if assigned.
- 3:** If Program Counter (PC) is modified or a conditional test is true, the instruction requires two cycles. The second cycle is executed as a NOP.
- 4:** Some instructions are two-word instructions. The second word of these instructions will be executed as a NOP unless the first word of the instruction retrieves the information embedded in these 16-bits. This ensures that all program memory locations have a valid instruction.

PIC18F85J90 FAMILY

TABLE 23-2: PIC18F85J90 FAMILY INSTRUCTION SET (CONTINUED)

Mnemonic, Operands	Description	Cycles	16-bit Instruction Word				Status Affected	Notes
			MSb			LSb		
LITERAL OPERATIONS								
ADDLW	k	Add literal and WREG	1	0000	1111	kkkk	kkkk	C, DC, Z, OV, N
ANDLW	k	AND literal with WREG	1	0000	1011	kkkk	kkkk	Z, N
IORLW	k	Inclusive OR literal with WREG	1	0000	1001	kkkk	kkkk	Z, N
LFSR	f, k	Move literal (12-bit) 2nd word to FSR(f) 1st word	2	1110	1110	00ff	kkkk	None
MOVLB	k	Move literal to BSR<3:0>	1	0000	0001	0000	kkkk	None
MOVLW	k	Move literal to WREG	1	0000	1110	kkkk	kkkk	None
MULLW	k	Multiply literal with WREG	1	0000	1101	kkkk	kkkk	None
RETLW	k	Return with literal in WREG	2	0000	1100	kkkk	kkkk	None
SUBLW	k	Subtract WREG from literal	1	0000	1000	kkkk	kkkk	C, DC, Z, OV, N
XORLW	k	Exclusive OR literal with WREG	1	0000	1010	kkkk	kkkk	Z, N
DATA MEMORY ↔ PROGRAM MEMORY OPERATIONS								
TBLRD*		Table Read	2	0000	0000	0000	1000	None
TBLRD*+		Table Read with post-increment		0000	0000	0000	1001	None
TBLRD*-		Table Read with post-decrement		0000	0000	0000	1010	None
TBLRD+*		Table Read with pre-increment		0000	0000	0000	1011	None
TBLWT*		Table Write	2	0000	0000	0000	1100	None
TBLWT*+		Table Write with post-increment		0000	0000	0000	1101	None
TBLWT*-		Table Write with post-decrement		0000	0000	0000	1110	None
TBLWT+*		Table Write with pre-increment		0000	0000	0000	1111	None

- Note 1:** When a PORT register is modified as a function of itself (e.g., `MOVF PORTB, 1, 0`), the value used will be that value present on the pins themselves. For example, if the data latch is '1' for a pin configured as input and is driven low by an external device, the data will be written back with a '0'.
- If this instruction is executed on the TMR0 register (and, where applicable, $d = 1$), the prescaler will be cleared if assigned.
 - If Program Counter (PC) is modified or a conditional test is true, the instruction requires two cycles. The second cycle is executed as a NOP.
 - Some instructions are two-word instructions. The second word of these instructions will be executed as a NOP unless the first word of the instruction retrieves the information embedded in these 16-bits. This ensures that all program memory locations have a valid instruction.

PIC18F85J90 FAMILY

23.1.1 STANDARD INSTRUCTION SET

ADDLW	ADD Literal to W								
Syntax:	ADDLW k								
Operands:	$0 \leq k \leq 255$								
Operation:	$(W) + k \rightarrow W$								
Status Affected:	N, OV, C, DC, Z								
Encoding:	<table border="1" style="display: inline-table;"><tr><td>0000</td><td>1111</td><td>kkkk</td><td>kkkk</td></tr></table>	0000	1111	kkkk	kkkk				
0000	1111	kkkk	kkkk						
Description:	The contents of W are added to the 8-bit literal 'k' and the result is placed in W.								
Words:	1								
Cycles:	1								
Q Cycle Activity:	<table border="1" style="display: inline-table;"><thead><tr><th>Q1</th><th>Q2</th><th>Q3</th><th>Q4</th></tr></thead><tbody><tr><td>Decode</td><td>Read literal 'k'</td><td>Process Data</td><td>Write to W</td></tr></tbody></table>	Q1	Q2	Q3	Q4	Decode	Read literal 'k'	Process Data	Write to W
Q1	Q2	Q3	Q4						
Decode	Read literal 'k'	Process Data	Write to W						

Example: ADDLW 15h

Before Instruction
W = 10h
After Instruction
W = 25h

ADDWF	ADD W to f								
Syntax:	ADDWF f {,d {,a}}								
Operands:	$0 \leq f \leq 255$ $d \in [0,1]$ $a \in [0,1]$								
Operation:	$(W) + (f) \rightarrow \text{dest}$								
Status Affected:	N, OV, C, DC, Z								
Encoding:	<table border="1" style="display: inline-table;"><tr><td>0010</td><td>01da</td><td>ffff</td><td>ffff</td></tr></table>	0010	01da	ffff	ffff				
0010	01da	ffff	ffff						
Description:	Add W to register 'f'. If 'd' is '0', the result is stored in W. If 'd' is '1', the result is stored back in register 'f' (default). If 'a' is '0', the Access Bank is selected. If 'a' is '1', the BSR is used to select the GPR bank (default). If 'a' is '0' and the extended instruction set is enabled, this instruction operates in Indexed Literal Offset Addressing mode whenever $f \leq 95$ (5Fh). See Section 23.2.3 "Byte-Oriented and Bit-Oriented Instructions in Indexed Literal Offset Mode" for details.								
Words:	1								
Cycles:	1								
Q Cycle Activity:	<table border="1" style="display: inline-table;"><thead><tr><th>Q1</th><th>Q2</th><th>Q3</th><th>Q4</th></tr></thead><tbody><tr><td>Decode</td><td>Read register 'f'</td><td>Process Data</td><td>Write to destination</td></tr></tbody></table>	Q1	Q2	Q3	Q4	Decode	Read register 'f'	Process Data	Write to destination
Q1	Q2	Q3	Q4						
Decode	Read register 'f'	Process Data	Write to destination						

Example: ADDWF REG, 0, 0

Before Instruction
W = 17h
REG = 0C2h
After Instruction
W = 0D9h
REG = 0C2h

Note: All PIC18 instructions may take an optional label argument preceding the instruction mnemonic for use in symbolic addressing. If a label is used, the instruction format then becomes: {label} instruction argument(s).

PIC18F85J90 FAMILY

ADDWFC ADD W and Carry bit to f

Syntax: ADDWFC f {,d {,a}}

Operands: $0 \leq f \leq 255$
 $d \in [0,1]$
 $a \in [0,1]$

Operation: $(W) + (f) + (C) \rightarrow \text{dest}$

Status Affected: N,OV, C, DC, Z

Encoding:

0010	00da	ffff	ffff
------	------	------	------

Description: Add W, the Carry flag and data memory location 'f'. If 'd' is '0', the result is placed in W. If 'd' is '1', the result is placed in data memory location 'f'.

 If 'a' is '0', the Access Bank is selected. If 'a' is '1', the BSR is used to select the GPR bank (default).

 If 'a' is '0' and the extended instruction set is enabled, this instruction operates in Indexed Literal Offset Addressing mode whenever $f \leq 95$ (5Fh). See **Section 23.2.3 "Byte-Oriented and Bit-Oriented Instructions in Indexed Literal Offset Mode"** for details.

Words: 1

Cycles: 1

Q Cycle Activity:

Q1	Q2	Q3	Q4
Decode	Read register 'f'	Process Data	Write to destination

Example: ADDWFC REG, 0, 1

Before Instruction
 Carry bit = 1
 REG = 02h
 W = 4Dh

After Instruction
 Carry bit = 0
 REG = 02h
 W = 50h

ANDLW AND Literal with W

Syntax: ANDLW k

Operands: $0 \leq k \leq 255$

Operation: $(W) .\text{AND. } k \rightarrow W$

Status Affected: N, Z

Encoding:

0000	1011	kkkk	kkkk
------	------	------	------

Description: The contents of W are ANDed with the 8-bit literal 'k'. The result is placed in W.

Words: 1

Cycles: 1

Q Cycle Activity:

Q1	Q2	Q3	Q4
Decode	Read literal 'k'	Process Data	Write to W

Example: ANDLW 05Fh

Before Instruction
 W = A3h

After Instruction
 W = 03h

PIC18F85J90 FAMILY

ANDWF **AND W with f**

Syntax: ANDWF f {,d {,a}}

Operands: $0 \leq f \leq 255$
 $d \in [0,1]$
 $a \in [0,1]$

Operation: (W) .AND. (f) \rightarrow dest

Status Affected: N, Z

Encoding:

0001	01da	ffff	ffff
------	------	------	------

Description: The contents of W are ANDed with register 'f'. If 'd' is '0', the result is stored in W. If 'd' is '1', the result is stored back in register 'f' (default).

 If 'a' is '0', the Access Bank is selected. If 'a' is '1', the BSR is used to select the GPR bank (default).

 If 'a' is '0' and the extended instruction set is enabled, this instruction operates in Indexed Literal Offset Addressing mode whenever $f \leq 95$ (5Fh). See **Section 23.2.3 "Byte-Oriented and Bit-Oriented Instructions in Indexed Literal Offset Mode"** for details.

Words: 1

Cycles: 1

Q Cycle Activity:

Q1	Q2	Q3	Q4
Decode	Read register 'f'	Process Data	Write to destination

Example: ANDWF REG, 0, 0

Before Instruction
W = 17h
REG = C2h

After Instruction
W = 02h
REG = C2h

BC **Branch if Carry**

Syntax: BC n

Operands: $-128 \leq n \leq 127$

Operation: if Carry bit is '1',
(PC) + 2 + 2n \rightarrow PC

Status Affected: None

Encoding:

1110	0010	nnnn	nnnn
------	------	------	------

Description: If the Carry bit is '1', then the program will branch.

 The 2's complement number '2n' is added to the PC. Since the PC will have incremented to fetch the next instruction, the new address will be PC + 2 + 2n. This instruction is then a two-cycle instruction.

Words: 1

Cycles: 1(2)

Q Cycle Activity:
If Jump:

Q1	Q2	Q3	Q4
Decode	Read literal 'n'	Process Data	Write to PC
No operation	No operation	No operation	No operation

If No Jump:

Q1	Q2	Q3	Q4
Decode	Read literal 'n'	Process Data	No operation

Example: HERE BC 5

Before Instruction
PC = address (HERE)

After Instruction
If Carry = 1;
PC = address (HERE + 12)
If Carry = 0;
PC = address (HERE + 2)

PIC18F85J90 FAMILY

BCF Bit Clear f

Syntax: BCF f, b {,a}

Operands: $0 \leq f \leq 255$
 $0 \leq b \leq 7$
 $a \in [0,1]$

Operation: $0 \rightarrow f < b$

Status Affected: None

Encoding:

1001	bbba	ffff	ffff
------	------	------	------

Description: Bit 'b' in register 'f' is cleared.

If 'a' is '0', the Access Bank is selected.
 If 'a' is '1', the BSR is used to select the GPR bank (default).

If 'a' is '0' and the extended instruction set is enabled, this instruction operates in Indexed Literal Offset Addressing mode whenever $f \leq 95$ (5Fh). See **Section 23.2.3 "Byte-Oriented and Bit-Oriented Instructions in Indexed Literal Offset Mode"** for details.

Words: 1

Cycles: 1

Q Cycle Activity:

Q1	Q2	Q3	Q4
Decode	Read register 'f'	Process Data	Write register 'f'

Example: BCF FLAG_REG, 7, 0

Before Instruction
 FLAG_REG = C7h
 After Instruction
 FLAG_REG = 47h

BN Branch if Negative

Syntax: BN n

Operands: $-128 \leq n \leq 127$

Operation: if Negative bit is '1',
 $(PC) + 2 + 2n \rightarrow PC$

Status Affected: None

Encoding:

1110	0110	nnnn	nnnn
------	------	------	------

Description: If the Negative bit is '1', then the program will branch.

The 2's complement number '2n' is added to the PC. Since the PC will have incremented to fetch the next instruction, the new address will be $PC + 2 + 2n$. This instruction is then a two-cycle instruction.

Words: 1

Cycles: 1(2)

Q Cycle Activity:

If Jump:

Q1	Q2	Q3	Q4
Decode	Read literal 'n'	Process Data	Write to PC
No operation	No operation	No operation	No operation

If No Jump:

Q1	Q2	Q3	Q4
Decode	Read literal 'n'	Process Data	No operation

Example: HERE BN Jump

Before Instruction
 PC = address (HERE)

After Instruction
 If Negative = 1;
 PC = address (Jump)
 If Negative = 0;
 PC = address (HERE + 2)

PIC18F85J90 FAMILY

BNC Branch if Not Carry

Syntax: BNC n
 Operands: $-128 \leq n \leq 127$
 Operation: if Carry bit is '0',
 $(PC) + 2 + 2n \rightarrow PC$
 Status Affected: None
 Encoding:

1110	0011	nnnn	nnnn
------	------	------	------

 Description: If the Carry bit is '0', then the program will branch.
 The 2's complement number '2n' is added to the PC. Since the PC will have incremented to fetch the next instruction, the new address will be $PC + 2 + 2n$. This instruction is then a two-cycle instruction.
 Words: 1
 Cycles: 1(2)

Q Cycle Activity:
 If Jump:

Q1	Q2	Q3	Q4
Decode	Read literal 'n'	Process Data	Write to PC
No operation	No operation	No operation	No operation

If No Jump:

Q1	Q2	Q3	Q4
Decode	Read literal 'n'	Process Data	No operation

Example: HERE BNC Jump
 Before Instruction
 PC = address (HERE)
 After Instruction
 If Carry = 0;
 PC = address (Jump)
 If Carry = 1;
 PC = address (HERE + 2)

BNN Branch if Not Negative

Syntax: BNN n
 Operands: $-128 \leq n \leq 127$
 Operation: if Negative bit is '0',
 $(PC) + 2 + 2n \rightarrow PC$
 Status Affected: None
 Encoding:

1110	0111	nnnn	nnnn
------	------	------	------

 Description: If the Negative bit is '0', then the program will branch.
 The 2's complement number '2n' is added to the PC. Since the PC will have incremented to fetch the next instruction, the new address will be $PC + 2 + 2n$. This instruction is then a two-cycle instruction.
 Words: 1
 Cycles: 1(2)

Q Cycle Activity:
 If Jump:

Q1	Q2	Q3	Q4
Decode	Read literal 'n'	Process Data	Write to PC
No operation	No operation	No operation	No operation

If No Jump:

Q1	Q2	Q3	Q4
Decode	Read literal 'n'	Process Data	No operation

Example: HERE BNN Jump
 Before Instruction
 PC = address (HERE)
 After Instruction
 If Negative = 0;
 PC = address (Jump)
 If Negative = 1;
 PC = address (HERE + 2)

PIC18F85J90 FAMILY

BNOV Branch if Not Overflow

Syntax: BNOV n
 Operands: $-128 \leq n \leq 127$
 Operation: if Overflow bit is '0',
 $(PC) + 2 + 2n \rightarrow PC$
 Status Affected: None
 Encoding:

1110	0101	nnnn	nnnn
------	------	------	------

 Description: If the Overflow bit is '0', then the program will branch.
 The 2's complement number '2n' is added to the PC. Since the PC will have incremented to fetch the next instruction, the new address will be $PC + 2 + 2n$. This instruction is then a two-cycle instruction.
 Words: 1
 Cycles: 1(2)

Q Cycle Activity:
 If Jump:

Q1	Q2	Q3	Q4
Decode	Read literal 'n'	Process Data	Write to PC
No operation	No operation	No operation	No operation

If No Jump:

Q1	Q2	Q3	Q4
Decode	Read literal 'n'	Process Data	No operation

Example: HERE BNOV Jump

Before Instruction
 PC = address (HERE)
 After Instruction
 If Overflow = 0;
 PC = address (Jump)
 If Overflow = 1;
 PC = address (HERE + 2)

BNZ Branch if Not Zero

Syntax: BNZ n
 Operands: $-128 \leq n \leq 127$
 Operation: if Zero bit is '0',
 $(PC) + 2 + 2n \rightarrow PC$
 Status Affected: None
 Encoding:

1110	0001	nnnn	nnnn
------	------	------	------

 Description: If the Zero bit is '0', then the program will branch.
 The 2's complement number '2n' is added to the PC. Since the PC will have incremented to fetch the next instruction, the new address will be $PC + 2 + 2n$. This instruction is then a two-cycle instruction.
 Words: 1
 Cycles: 1(2)

Q Cycle Activity:
 If Jump:

Q1	Q2	Q3	Q4
Decode	Read literal 'n'	Process Data	Write to PC
No operation	No operation	No operation	No operation

If No Jump:

Q1	Q2	Q3	Q4
Decode	Read literal 'n'	Process Data	No operation

Example: HERE BNZ Jump

Before Instruction
 PC = address (HERE)
 After Instruction
 If Zero = 0;
 PC = address (Jump)
 If Zero = 1;
 PC = address (HERE + 2)

PIC18F85J90 FAMILY

BRA Unconditional Branch

Syntax: BRA n
 Operands: $-1024 \leq n \leq 1023$
 Operation: $(PC) + 2 + 2n \rightarrow PC$
 Status Affected: None
 Encoding:

1101	0nnn	nnnn	nnnn
------	------	------	------

 Description: Add the 2's complement number '2n' to the PC. Since the PC will have incremented to fetch the next instruction, the new address will be $PC + 2 + 2n$. This instruction is a two-cycle instruction.
 Words: 1
 Cycles: 2

Q Cycle Activity:

	Q1	Q2	Q3	Q4
Decode	Read literal 'n'	Process Data	Write to PC	
No operation	No operation	No operation	No operation	No operation

Example: HERE BRA Jump
 Before Instruction
 PC = address (HERE)
 After Instruction
 PC = address (Jump)

BSF Bit Set f

Syntax: BSF f, b {,a}
 Operands: $0 \leq f \leq 255$
 $0 \leq b \leq 7$
 $a \in [0,1]$
 Operation: $1 \rightarrow f < b >$
 Status Affected: None
 Encoding:

1000	bbba	ffff	ffff
------	------	------	------

 Description: Bit 'b' in register 'f' is set.
 If 'a' is '0', the Access Bank is selected.
 If 'a' is '1', the BSR is used to select the GPR bank (default).
 If 'a' is '0' and the extended instruction set is enabled, this instruction operates in Indexed Literal Offset Addressing mode whenever $f \leq 95$ (5Fh). See **Section 23.2.3 "Byte-Oriented and Bit-Oriented Instructions in Indexed Literal Offset Mode"** for details.

Words: 1
 Cycles: 1

Q Cycle Activity:

	Q1	Q2	Q3	Q4
Decode	Read register 'f'	Process Data	Write register 'f'	

Example: BSF FLAG_REG, 7, 1
 Before Instruction
 FLAG_REG = 0Ah
 After Instruction
 FLAG_REG = 8Ah

PIC18F85J90 FAMILY

BTFSC Bit Test File, Skip if Clear

Syntax: BTFSC f, b {,a}
 Operands: $0 \leq f \leq 255$
 $0 \leq b \leq 7$
 $a \in [0,1]$

Operation: skip if (f) = 0
 Status Affected: None

Encoding:

1011	bbba	ffff	ffff
------	------	------	------

Description: If bit 'b' in register 'f' is '0', then the next instruction is skipped. If bit 'b' is '1', then the next instruction fetched during the current instruction execution is discarded and a NOP is executed instead, making this a two-cycle instruction.

If 'a' is '0', the Access Bank is selected. If 'a' is '1', the BSR is used to select the GPR bank (default).

If 'a' is '0' and the extended instruction set is enabled, this instruction operates in Indexed Literal Offset Addressing mode whenever $f \leq 95$ (5Fh). See

Section 23.2.3 "Byte-Oriented and Bit-Oriented Instructions in Indexed Literal Offset Mode" for details.

Words: 1

Cycles: 1(2)
Note: 3 cycles if skip and followed by a 2-word instruction.

Q Cycle Activity:

Q1	Q2	Q3	Q4
Decode	Read register 'f'	Process Data	No operation

If skip:

Q1	Q2	Q3	Q4
No operation	No operation	No operation	No operation

If skip and followed by 2-word instruction:

Q1	Q2	Q3	Q4
No operation	No operation	No operation	No operation
No operation	No operation	No operation	No operation

Example:
 HERE BTFSC FLAG, 1, 0
 FALSE :
 TRUE :

Before Instruction
 PC = address (HERE)
 After Instruction
 If FLAG<1> = 0;
 PC = address (TRUE)
 If FLAG<1> = 1;
 PC = address (FALSE)

BTFSS Bit Test File, Skip if Set

Syntax: BTFSS f, b {,a}
 Operands: $0 \leq f \leq 255$
 $0 \leq b < 7$
 $a \in [0,1]$

Operation: skip if (f) = 1
 Status Affected: None

Encoding:

1010	bbba	ffff	ffff
------	------	------	------

Description: If bit 'b' in register 'f' is '1', then the next instruction is skipped. If bit 'b' is '0', then the next instruction fetched during the current instruction execution is discarded and a NOP is executed instead, making this a two-cycle instruction.

If 'a' is '0', the Access Bank is selected. If 'a' is '1', the BSR is used to select the GPR bank (default).

If 'a' is '0' and the extended instruction set is enabled, this instruction operates in Indexed Literal Offset Addressing mode whenever $f \leq 95$ (5Fh). See

Section 23.2.3 "Byte-Oriented and Bit-Oriented Instructions in Indexed Literal Offset Mode" for details.

Words: 1

Cycles: 1(2)
Note: 3 cycles if skip and followed by a 2-word instruction.

Q Cycle Activity:

Q1	Q2	Q3	Q4
Decode	Read register 'f'	Process Data	No operation

If skip:

Q1	Q2	Q3	Q4
No operation	No operation	No operation	No operation

If skip and followed by 2-word instruction:

Q1	Q2	Q3	Q4
No operation	No operation	No operation	No operation
No operation	No operation	No operation	No operation

Example:
 HERE BTFSS FLAG, 1, 0
 FALSE :
 TRUE :

Before Instruction
 PC = address (HERE)
 After Instruction
 If FLAG<1> = 0;
 PC = address (FALSE)
 If FLAG<1> = 1;
 PC = address (TRUE)

PIC18F85J90 FAMILY

BTG **Bit Toggle f**

Syntax: BTG f, b {,a}

Operands: $0 \leq f \leq 255$
 $0 \leq b < 7$
 $a \in [0,1]$

Operation: $\overline{f\langle b \rangle} \rightarrow f\langle b \rangle$

Status Affected: None

Encoding:

0111	bbba	ffff	ffff
------	------	------	------

Description: Bit 'b' in data memory location 'f' is inverted.

 If 'a' is '0', the Access Bank is selected.
 If 'a' is '1', the BSR is used to select the GPR bank (default).

 If 'a' is '0' and the extended instruction set is enabled, this instruction operates in Indexed Literal Offset Addressing mode whenever $f \leq 95$ (5Fh). See **Section 23.2.3 "Byte-Oriented and Bit-Oriented Instructions in Indexed Literal Offset Mode"** for details.

Words: 1

Cycles: 1

Q Cycle Activity:

Q1	Q2	Q3	Q4
Decode	Read register 'f'	Process Data	Write register 'f'

Example: BTG PORTC, 4, 0

Before Instruction:
PORTC = 0111 0101 [75h]
After Instruction:
PORTC = 0110 0101 [65h]

BOV **Branch if Overflow**

Syntax: BOV n

Operands: $-128 \leq n \leq 127$

Operation: if Overflow bit is '1',
 $(PC) + 2 + 2n \rightarrow PC$

Status Affected: None

Encoding:

1110	0100	nnnn	nnnn
------	------	------	------

Description: If the Overflow bit is '1', then the program will branch.

 The 2's complement number '2n' is added to the PC. Since the PC will have incremented to fetch the next instruction, the new address will be $PC + 2 + 2n$. This instruction is then a two-cycle instruction.

Words: 1

Cycles: 1(2)

Q Cycle Activity:
If Jump:

Q1	Q2	Q3	Q4
Decode	Read literal 'n'	Process Data	Write to PC
No operation	No operation	No operation	No operation

If No Jump:

Q1	Q2	Q3	Q4
Decode	Read literal 'n'	Process Data	No operation

Example: HERE BOV Jump

Before Instruction
PC = address (HERE)
After Instruction
If Overflow = 1;
PC = address (Jump)
If Overflow = 0;
PC = address (HERE + 2)

PIC18F85J90 FAMILY

BZ Branch if Zero

Syntax: BZ n

Operands: $-128 \leq n \leq 127$

Operation: if Zero bit is '1',
 $(PC) + 2 + 2n \rightarrow PC$

Status Affected: None

Encoding:

1110	0000	nnnn	nnnn
------	------	------	------

Description: If the Zero bit is '1', then the program will branch.
 The 2's complement number '2n' is added to the PC. Since the PC will have incremented to fetch the next instruction, the new address will be $PC + 2 + 2n$. This instruction is then a two-cycle instruction.

Words: 1

Cycles: 1(2)

Q Cycle Activity:
 If Jump:

Q1	Q2	Q3	Q4
Decode	Read literal 'n'	Process Data	Write to PC
No operation	No operation	No operation	No operation

If No Jump:

Q1	Q2	Q3	Q4
Decode	Read literal 'n'	Process Data	No operation

Example: HERE BZ Jump

Before Instruction
 PC = address (HERE)

After Instruction
 If Zero = 1;
 PC = address (Jump)
 If Zero = 0;
 PC = address (HERE + 2)

CALL Subroutine Call

Syntax: CALL k {,s}

Operands: $0 \leq k \leq 1048575$
 $s \in [0,1]$

Operation: $(PC) + 4 \rightarrow TOS$,
 $k \rightarrow PC<20:1>$;
 if $s = 1$
 $(W) \rightarrow WS$,
 $(STATUS) \rightarrow STATUSS$,
 $(BSR) \rightarrow BSRS$

Status Affected: None

Encoding:
 1st word ($k<7:0>$)

1110	110s	k_7kkk	$kkkk_0$
------	------	----------	----------

 2nd word ($k<19:8>$)

1111	$k_{19}kkk$	$kkkk$	$kkkk_8$
------	-------------	--------	----------

Description: Subroutine call of entire 2-Mbyte memory range. First, return address ($PC + 4$) is pushed onto the return stack. If 's' = 1, the W, STATUS and BSR registers are also pushed into their respective shadow registers, WS, STATUSS and BSRS. If 's' = 0, no update occurs (default). Then, the 20-bit value 'k' is loaded into $PC<20:1>$. CALL is a two-cycle instruction.

Words: 2

Cycles: 2

Q Cycle Activity:

Q1	Q2	Q3	Q4
Decode	Read literal 'k'<7:0>, Push PC to stack	Push PC to stack	Read literal 'k'<19:8>, Write to PC
No operation	No operation	No operation	No operation

Example: HERE CALL THERE, 1

Before Instruction
 PC = address (HERE)

After Instruction
 PC = address (THERE)
 TOS = address (HERE + 4)
 WS = W
 BSRS = BSR
 STATUSS = STATUS

PIC18F85J90 FAMILY

CLRF **Clear f**

Syntax: CLRF f{,a}

Operands: $0 \leq f \leq 255$
 $a \in [0,1]$

Operation: $000h \rightarrow f$,
 $1 \rightarrow Z$

Status Affected: Z

Encoding:

0110	101a	ffff	ffff
------	------	------	------

Description: Clears the contents of the specified register.

 If 'a' is '0', the Access Bank is selected.
 If 'a' is '1', the BSR is used to select the GPR bank (default).

 If 'a' is '0' and the extended instruction set is enabled, this instruction operates in Indexed Literal Offset Addressing mode whenever $f \leq 95$ (5Fh). See **Section 23.2.3 "Byte-Oriented and Bit-Oriented Instructions in Indexed Literal Offset Mode"** for details.

Words: 1

Cycles: 1

Q Cycle Activity:

Q1	Q2	Q3	Q4
Decode	Read register 'f'	Process Data	Write register 'f'

Example: CLRF FLAG_REG, 1

Before Instruction
FLAG_REG = 5Ah

After Instruction
FLAG_REG = 00h

CLRWDT **Clear Watchdog Timer**

Syntax: CLRWDT

Operands: None

Operation: $000h \rightarrow WDT$,
 $000h \rightarrow WDT$ postscaler,
 $1 \rightarrow \overline{TO}$,
 $1 \rightarrow PD$

Status Affected: \overline{TO} , \overline{PD}

Encoding:

0000	0000	0000	0100
------	------	------	------

Description: CLRWDT instruction resets the Watchdog Timer. It also resets the postscaler of the WDT. Status bits, \overline{TO} and \overline{PD} , are set.

Words: 1

Cycles: 1

Q Cycle Activity:

Q1	Q2	Q3	Q4
Decode	No operation	Process Data	No operation

Example: CLRWDT

Before Instruction
WDT Counter = ?

After Instruction
WDT Counter = 00h
WDT Postscaler = 0
 \overline{TO} = 1
 \overline{PD} = 1

PIC18F85J90 FAMILY

COMF Complement f

Syntax: COMF f {,d {,a}}

Operands: $0 \leq f \leq 255$
 $d \in [0,1]$
 $a \in [0,1]$

Operation: $\bar{f} \rightarrow \text{dest}$

Status Affected: N, Z

Encoding:

0001	11da	ffff	ffff
------	------	------	------

Description: The contents of register 'f' are complemented. If 'd' is '0', the result is stored in W. If 'd' is '1', the result is stored back in register 'f' (default).
 If 'a' is '0', the Access Bank is selected. If 'a' is '1', the BSR is used to select the GPR bank (default).
 If 'a' is '0' and the extended instruction set is enabled, this instruction operates in Indexed Literal Offset Addressing mode whenever $f \leq 95$ (5Fh). See **Section 23.2.3 "Byte-Oriented and Bit-Oriented Instructions in Indexed Literal Offset Mode"** for details.

Words: 1

Cycles: 1

Q Cycle Activity:

Q1	Q2	Q3	Q4
Decode	Read register 'f'	Process Data	Write to destination

Example: COMF REG, 0, 0

Before Instruction
 REG = 13h

After Instruction
 REG = 13h
 W = ECh

CPFSEQ Compare f with W, Skip if f = W

Syntax: CPFSEQ f {,a}

Operands: $0 \leq f \leq 255$
 $a \in [0,1]$

Operation: $(f) - (W)$,
 skip if $(f) = (W)$
 (unsigned comparison)

Status Affected: None

Encoding:

0110	001a	ffff	ffff
------	------	------	------

Description: Compares the contents of data memory location 'f' to the contents of W by performing an unsigned subtraction.
 If $f = W$, then the fetched instruction is discarded and a NOP is executed instead, making this a two-cycle instruction.
 If 'a' is '0', the Access Bank is selected. If 'a' is '1', the BSR is used to select the GPR bank (default).
 If 'a' is '0' and the extended instruction set is enabled, this instruction operates in Indexed Literal Offset Addressing mode whenever $f \leq 95$ (5Fh). See **Section 23.2.3 "Byte-Oriented and Bit-Oriented Instructions in Indexed Literal Offset Mode"** for details.

Words: 1

Cycles: 1(2)
Note: 3 cycles if skip and followed by a 2-word instruction.

Q Cycle Activity:

Q1	Q2	Q3	Q4
Decode	Read register 'f'	Process Data	No operation

If skip:

Q1	Q2	Q3	Q4
No operation	No operation	No operation	No operation

If skip and followed by 2-word instruction:

Q1	Q2	Q3	Q4
No operation	No operation	No operation	No operation
No operation	No operation	No operation	No operation

Example: HERE CPFSEQ REG, 0
 NEQUAL :
 EQUAL :

Before Instruction
 PC Address = HERE
 W = ?
 REG = ?

After Instruction
 If REG = W;
 PC = Address (EQUAL)
 If REG \neq W;
 PC = Address (NEQUAL)

PIC18F85J90 FAMILY

CPFSGT Compare f with W, Skip if f > W

Syntax: CPFSGT f{,a}
 Operands: $0 \leq f \leq 255$
 $a \in [0,1]$
 Operation: $(f) - (W)$,
 skip if $(f) > (W)$
 (unsigned comparison)
 Status Affected: None

Encoding:

0110	010a	ffff	ffff
------	------	------	------

Description: Compares the contents of data memory location 'f' to the contents of the W by performing an unsigned subtraction.
 If the contents of 'f' are greater than the contents of WREG, then the fetched instruction is discarded and a NOP is executed instead, making this a two-cycle instruction.
 If 'a' is '0', the Access Bank is selected. If 'a' is '1', the BSR is used to select the GPR bank (default).
 If 'a' is '0' and the extended instruction set is enabled, this instruction operates in Indexed Literal Offset Addressing mode whenever $f \leq 95$ (5Fh). See **Section 23.2.3 "Byte-Oriented and Bit-Oriented Instructions in Indexed Literal Offset Mode"** for details.

Words: 1
 Cycles: 1(2)
Note: 3 cycles if skip and followed by a 2-word instruction.

Q Cycle Activity:

Q1	Q2	Q3	Q4
Decode	Read register 'f'	Process Data	No operation

If skip:

Q1	Q2	Q3	Q4
No operation	No operation	No operation	No operation

If skip and followed by 2-word instruction:

Q1	Q2	Q3	Q4
No operation	No operation	No operation	No operation
No operation	No operation	No operation	No operation

Example: HERE CPFSGT REG, 0
 NGREATER :
 GREATER :
 Before Instruction
 PC = Address (HERE)
 W = ?
 After Instruction
 If REG > W;
 PC = Address (GREATER)
 If REG ≤ W;
 PC = Address (NGREATER)

CPFSLT Compare f with W, Skip if f < W

Syntax: CPFSLT f{,a}
 Operands: $0 \leq f \leq 255$
 $a \in [0,1]$
 Operation: $(f) - (W)$,
 skip if $(f) < (W)$
 (unsigned comparison)
 Status Affected: None

Encoding:

0110	000a	ffff	ffff
------	------	------	------

Description: Compares the contents of data memory location 'f' to the contents of W by performing an unsigned subtraction.
 If the contents of 'f' are less than the contents of W, then the fetched instruction is discarded and a NOP is executed instead, making this a two-cycle instruction.
 If 'a' is '0', the Access Bank is selected. If 'a' is '1', the BSR is used to select the GPR bank (default).
 Words: 1
 Cycles: 1(2)
Note: 3 cycles if skip and followed by a 2-word instruction.

Q Cycle Activity:

Q1	Q2	Q3	Q4
Decode	Read register 'f'	Process Data	No operation

If skip:

Q1	Q2	Q3	Q4
No operation	No operation	No operation	No operation

If skip and followed by 2-word instruction:

Q1	Q2	Q3	Q4
No operation	No operation	No operation	No operation
No operation	No operation	No operation	No operation

Example: HERE CPFSLT REG, 1
 NLESS :
 LESS :

Before Instruction
 PC = Address (HERE)
 W = ?
 After Instruction
 If REG < W;
 PC = Address (LESS)
 If REG ≥ W;
 PC = Address (NLESS)

PIC18F85J90 FAMILY

DAW Decimal Adjust W Register

Syntax: DAW

Operands: None

Operation: If $[W<3:0> > 9]$ or $[DC = 1]$, then $(W<3:0>) + 6 \rightarrow W<3:0>$;
else $(W<3:0>) \rightarrow W<3:0>$

If $[W<7:4> > 9]$ or $[C = 1]$, then $(W<7:4>) + 6 \rightarrow W<7:4>$;
 $C = 1$;
else $(W<7:4>) \rightarrow W<7:4>$

Status Affected: C

Encoding:

0000	0000	0000	0111
------	------	------	------

Description: DAW adjusts the eight-bit value in W, resulting from the earlier addition of two variables (each in packed BCD format) and produces a correct packed BCD result.

Words: 1

Cycles: 1

Q Cycle Activity:

Q1	Q2	Q3	Q4
Decode	Read register W	Process Data	Write W

Example 1: DAW

Before Instruction

W = A5h
C = 0
DC = 0

After Instruction

W = 05h
C = 1
DC = 0

Example 2:

Before Instruction

W = CEh
C = 0
DC = 0

After Instruction

W = 34h
C = 1
DC = 0

DECF Decrement f

Syntax: DECF f{,d{,a}}

Operands: $0 \leq f \leq 255$
 $d \in [0,1]$
 $a \in [0,1]$

Operation: $(f) - 1 \rightarrow \text{dest}$

Status Affected: C, DC, N, OV, Z

Encoding:

0000	01da	ffff	ffff
------	------	------	------

Description: Decrement register 'f'. If 'd' is '0', the result is stored in W. If 'd' is '1', the result is stored back in register 'f' (default).

If 'a' is '0', the Access Bank is selected. If 'a' is '1', the BSR is used to select the GPR bank (default).

If 'a' is '0' and the extended instruction set is enabled, this instruction operates in Indexed Literal Offset Addressing mode whenever $f \leq 95$ (5Fh). See **Section 23.2.3 "Byte-Oriented and Bit-Oriented Instructions in Indexed Literal Offset Mode"** for details.

Words: 1

Cycles: 1

Q Cycle Activity:

Q1	Q2	Q3	Q4
Decode	Read register 'f'	Process Data	Write to destination

Example: DECF CNT, 1, 0

Before Instruction

CNT = 01h
Z = 0

After Instruction

CNT = 00h
Z = 1

PIC18F85J90 FAMILY

GOTO Unconditional Branch

Syntax: GOTO k
 Operands: $0 \leq k \leq 1048575$
 Operation: $k \rightarrow PC<20:1>$

Status Affected: None

Encoding:

1110	1111	k_7kkk	$kkkk_0$
1111	$k_{19}kkk$	$kkkk$	$kkkk_8$

Description: GOTO allows an unconditional branch anywhere within entire 2-Mbyte memory range. The 20-bit value 'k' is loaded into PC<20:1>. GOTO is always a two-cycle instruction.

Words: 2

Cycles: 2

Q Cycle Activity:

Q1	Q2	Q3	Q4
Decode	Read literal 'k'<7:0>,>	No operation	Read literal 'k'<19:8>,> Write to PC
No operation	No operation	No operation	No operation

Example: GOTO THERE

After Instruction
 PC = Address (THERE)

INCF Increment f

Syntax: INCF f{,d{,a}}

Operands: $0 \leq f \leq 255$
 $d \in [0,1]$
 $a \in [0,1]$

Operation: $(f) + 1 \rightarrow dest$

Status Affected: C, DC, N, OV, Z

Encoding:

0010	10da	ffff	ffff
------	------	------	------

Description: The contents of register 'f' are incremented. If 'd' is '0', the result is placed in W. If 'd' is '1', the result is placed back in register 'f' (default).

If 'a' is '0', the Access Bank is selected. If 'a' is '1', the BSR is used to select the GPR bank (default).

If 'a' is '0' and the extended instruction set is enabled, this instruction operates in Indexed Literal Offset Addressing mode whenever $f \leq 95$ (5Fh). See **Section 23.2.3 "Byte-Oriented and Bit-Oriented Instructions in Indexed Literal Offset Mode"** for details.

Words: 1

Cycles: 1

Q Cycle Activity:

Q1	Q2	Q3	Q4
Decode	Read register 'f'	Process Data	Write to destination

Example: INCF CNT, 1, 0

Before Instruction
 CNT = FFh
 Z = 0
 C = ?
 DC = ?

After Instruction
 CNT = 00h
 Z = 1
 C = 1
 DC = 1

PIC18F85J90 FAMILY

INCFSZ **Increment f, Skip if 0**

Syntax: INCFSZ f {,d {,a}}

Operands: $0 \leq f \leq 255$
 $d \in [0,1]$
 $a \in [0,1]$

Operation: $(f) + 1 \rightarrow \text{dest}$,
skip if result = 0

Status Affected: None

Encoding:

0011	11da	ffff	ffff
------	------	------	------

Description: The contents of register 'f' are incremented. If 'd' is '0', the result is placed in W. If 'd' is '1', the result is placed back in register 'f'. (default)

 If the result is '0', the next instruction which is already fetched is discarded and a NOP is executed instead, making it a two-cycle instruction.

 If 'a' is '0', the Access Bank is selected. If 'a' is '1', the BSR is used to select the GPR bank (default).

 If 'a' is '0' and the extended instruction set is enabled, this instruction operates in Indexed Literal Offset Addressing mode whenever $f \leq 95$ (5Fh). See **Section 23.2.3 "Byte-Oriented and Bit-Oriented Instructions in Indexed Literal Offset Mode"** for details.

Words: 1

Cycles: 1(2)
Note: 3 cycles if skip and followed by a 2-word instruction.

Q Cycle Activity:

Q1	Q2	Q3	Q4
Decode	Read register 'f'	Process Data	Write to destination

If skip:

Q1	Q2	Q3	Q4
No operation	No operation	No operation	No operation

If skip and followed by 2-word instruction:

Q1	Q2	Q3	Q4
No operation	No operation	No operation	No operation
No operation	No operation	No operation	No operation

Example: HERE INCFSZ CNT, 1, 0
 NZERO :
 ZERO :

Before Instruction
PC = Address (HERE)

After Instruction
CNT = CNT + 1
If CNT = 0;
PC = Address (ZERO)
If CNT \neq 0;
PC = Address (NZERO)

INFSNZ **Increment f, Skip if Not 0**

Syntax: INFSNZ f {,d {,a}}

Operands: $0 \leq f \leq 255$
 $d \in [0,1]$
 $a \in [0,1]$

Operation: $(f) + 1 \rightarrow \text{dest}$,
skip if result $\neq 0$

Status Affected: None

Encoding:

0100	10da	ffff	ffff
------	------	------	------

Description: The contents of register 'f' are incremented. If 'd' is '0', the result is placed in W. If 'd' is '1', the result is placed back in register 'f' (default).

 If the result is not '0', the next instruction which is already fetched is discarded and a NOP is executed instead, making it a two-cycle instruction.

 If 'a' is '0', the Access Bank is selected. If 'a' is '1', the BSR is used to select the GPR bank (default).

 If 'a' is '0' and the extended instruction set is enabled, this instruction operates in Indexed Literal Offset Addressing mode whenever $f \leq 95$ (5Fh). See **Section 23.2.3 "Byte-Oriented and Bit-Oriented Instructions in Indexed Literal Offset Mode"** for details.

Words: 1

Cycles: 1(2)
Note: 3 cycles if skip and followed by a 2-word instruction.

Q Cycle Activity:

Q1	Q2	Q3	Q4
Decode	Read register 'f'	Process Data	Write to destination

If skip:

Q1	Q2	Q3	Q4
No operation	No operation	No operation	No operation

If skip and followed by 2-word instruction:

Q1	Q2	Q3	Q4
No operation	No operation	No operation	No operation
No operation	No operation	No operation	No operation

Example: HERE INFSNZ REG, 1, 0
 ZERO
 NZERO

Before Instruction
PC = Address (HERE)

After Instruction
REG = REG + 1
If REG \neq 0;
PC = Address (NZERO)
If REG = 0;
PC = Address (ZERO)

PIC18F85J90 FAMILY

IORLW Inclusive OR Literal with W

Syntax: IORLW k
 Operands: $0 \leq k \leq 255$
 Operation: (W) .OR. k \rightarrow W
 Status Affected: N, Z
 Encoding:

0000	1001	kkkk	kkkk
------	------	------	------

 Description: The contents of W are ORed with the eight-bit literal 'k'. The result is placed in W.
 Words: 1
 Cycles: 1

Q Cycle Activity:

Q1	Q2	Q3	Q4
Decode	Read literal 'k'	Process Data	Write to W

Example: IORLW 35h

Before Instruction
 W = 9Ah
 After Instruction
 W = BFh

IORWF Inclusive OR W with f

Syntax: IORWF f {,d {,a}}
 Operands: $0 \leq f \leq 255$
 $d \in [0,1]$
 $a \in [0,1]$
 Operation: (W) .OR. (f) \rightarrow dest
 Status Affected: N, Z
 Encoding:

0001	00da	ffff	ffff
------	------	------	------

 Description: Inclusive OR W with register 'f'. If 'd' is '0', the result is placed in W. If 'd' is '1', the result is placed back in register 'f' (default).

If 'a' is '0', the Access Bank is selected. If 'a' is '1', the BSR is used to select the GPR bank (default).

If 'a' is '0' and the extended instruction set is enabled, this instruction operates in Indexed Literal Offset Addressing mode whenever $f \leq 95$ (5Fh). See **Section 23.2.3 "Byte-Oriented and Bit-Oriented Instructions in Indexed Literal Offset Mode"** for details.

Words: 1

Cycles: 1

Q Cycle Activity:

Q1	Q2	Q3	Q4
Decode	Read register 'f'	Process Data	Write to destination

Example: IORWF RESULT, 0, 1

Before Instruction
 RESULT = 13h
 W = 91h
 After Instruction
 RESULT = 13h
 W = 93h

PIC18F85J90 FAMILY

LFSR	Load FSR															
Syntax:	LFSR f, k															
Operands:	0 ≤ f ≤ 2 0 ≤ k ≤ 4095															
Operation:	k → FSRf															
Status Affected:	None															
Encoding:	<table border="1"> <tr> <td>1110</td> <td>1110</td> <td>00ff</td> <td>k₁₁kkk</td> </tr> <tr> <td>1111</td> <td>0000</td> <td>k₇kkk</td> <td>kkkk</td> </tr> </table>	1110	1110	00ff	k ₁₁ kkk	1111	0000	k ₇ kkk	kkkk							
1110	1110	00ff	k ₁₁ kkk													
1111	0000	k ₇ kkk	kkkk													
Description:	The 12-bit literal 'k' is loaded into the file select register pointed to by 'f'.															
Words:	2															
Cycles:	2															
Q Cycle Activity:	<table border="1"> <thead> <tr> <th></th> <th>Q1</th> <th>Q2</th> <th>Q3</th> <th>Q4</th> </tr> </thead> <tbody> <tr> <td>Decode</td> <td>Read literal 'k' MSB</td> <td>Process Data</td> <td>Write literal 'k' MSB to FSRfH</td> <td></td> </tr> <tr> <td>Decode</td> <td>Read literal 'k' LSB</td> <td>Process Data</td> <td>Write literal 'k' to FSRfL</td> <td></td> </tr> </tbody> </table>		Q1	Q2	Q3	Q4	Decode	Read literal 'k' MSB	Process Data	Write literal 'k' MSB to FSRfH		Decode	Read literal 'k' LSB	Process Data	Write literal 'k' to FSRfL	
	Q1	Q2	Q3	Q4												
Decode	Read literal 'k' MSB	Process Data	Write literal 'k' MSB to FSRfH													
Decode	Read literal 'k' LSB	Process Data	Write literal 'k' to FSRfL													

Example: LFSR 2, 3ABh

After Instruction

FSR2H = 03h
FSR2L = ABh

MOVF	Move f										
Syntax:	MOVF f {,d {,a}}										
Operands:	0 ≤ f ≤ 255 d ∈ [0,1] a ∈ [0,1]										
Operation:	f → dest										
Status Affected:	N, Z										
Encoding:	<table border="1"> <tr> <td>0101</td> <td>00da</td> <td>ffff</td> <td>ffff</td> </tr> </table>	0101	00da	ffff	ffff						
0101	00da	ffff	ffff								
Description:	The contents of register 'f' are moved to a destination dependent upon the status of 'd'. If 'd' is '0', the result is placed in W. If 'd' is '1', the result is placed back in register 'f' (default). Location 'f' can be anywhere in the 256-byte bank. If 'a' is '0', the Access Bank is selected. If 'a' is '1', the BSR is used to select the GPR bank (default). If 'a' is '0' and the extended instruction set is enabled, this instruction operates in Indexed Literal Offset Addressing mode whenever f ≤ 95 (5Fh). See Section 23.2.3 "Byte-Oriented and Bit-Oriented Instructions in Indexed Literal Offset Mode" for details.										
Words:	1										
Cycles:	1										
Q Cycle Activity:	<table border="1"> <thead> <tr> <th></th> <th>Q1</th> <th>Q2</th> <th>Q3</th> <th>Q4</th> </tr> </thead> <tbody> <tr> <td>Decode</td> <td>Read register 'f'</td> <td>Process Data</td> <td>Write W</td> <td></td> </tr> </tbody> </table>		Q1	Q2	Q3	Q4	Decode	Read register 'f'	Process Data	Write W	
	Q1	Q2	Q3	Q4							
Decode	Read register 'f'	Process Data	Write W								

Example: MOVF REG, 0, 0

Before Instruction

REG = 22h
W = FFh

After Instruction

REG = 22h
W = 22h

PIC18F85J90 FAMILY

MOVFF Move f to f

Syntax: MOVFF f_s, f_d

Operands: $0 \leq f_s \leq 4095$
 $0 \leq f_d \leq 4095$

Operation: $(f_s) \rightarrow f_d$

Status Affected: None

Encoding:

1st word (source)	1100	ffff	ffff	ffff _s
2nd word (destin.)	1111	ffff	ffff	ffff _d

Description: The contents of source register ' f_s ' are moved to destination register ' f_d '. Location of source ' f_s ' can be anywhere in the 4096-byte data space (000h to FFFh) and location of destination ' f_d ' can also be anywhere from 000h to FFFh.

Either source or destination can be W (a useful special situation).

MOVFF is particularly useful for transferring a data memory location to a peripheral register (such as the transmit buffer or an I/O port).

The MOVFF instruction cannot use the PCL, TOSU, TOSH or TOSL as the destination register

Words: 2

Cycles: 2

Q Cycle Activity:

	Q1	Q2	Q3	Q4
Decode	Read register 'f' (src)	Process Data	No operation	
Decode	No operation No dummy read	No operation	Write register 'f' (dest)	

Example: MOVFF REG1, REG2

Before Instruction
 REG1 = 33h
 REG2 = 11h
 After Instruction
 REG1 = 33h
 REG2 = 33h

MOVLB Move Literal to Low Nibble in BSR

Syntax: MOVLW k

Operands: $0 \leq k \leq 255$

Operation: $k \rightarrow \text{BSR}$

Status Affected: None

Encoding:

0000	0001	kkkk	kkkk
------	------	------	------

Description: The eight-bit literal 'k' is loaded into the Bank Select Register (BSR). The value of BSR<7:4> always remains '0' regardless of the value of $k_7:k_4$.

Words: 1

Cycles: 1

Q Cycle Activity:

	Q1	Q2	Q3	Q4
Decode	Read literal 'k'	Process Data	Write literal 'k' to BSR	

Example: MOVLB 5

Before Instruction
 BSR Register = 02h
 After Instruction
 BSR Register = 05h

PIC18F85J90 FAMILY

MOVLW Move Literal to W

Syntax: MOVLW k
 Operands: $0 \leq k \leq 255$
 Operation: $k \rightarrow W$
 Status Affected: None
 Encoding:

0000	1110	kkkk	kkkk
------	------	------	------

 Description: The eight-bit literal 'k' is loaded into W.
 Words: 1
 Cycles: 1

Q Cycle Activity:

Q1	Q2	Q3	Q4
Decode	Read literal 'k'	Process Data	Write to W

Example: MOVLW 5Ah

After Instruction
 W = 5Ah

MOVWF Move W to f

Syntax: MOVWF f{,a}
 Operands: $0 \leq f \leq 255$
 $a \in [0,1]$
 Operation: $(W) \rightarrow f$
 Status Affected: None
 Encoding:

0110	111a	ffff	ffff
------	------	------	------

 Description: Move data from W to register 'f'. Location 'f' can be anywhere in the 256-byte bank.

If 'a' is '0', the Access Bank is selected. If 'a' is '1', the BSR is used to select the GPR bank (default).

If 'a' is '0' and the extended instruction set is enabled, this instruction operates in Indexed Literal Offset Addressing mode whenever $f \leq 95$ (5Fh). See **Section 23.2.3 "Byte-Oriented and Bit-Oriented Instructions in Indexed Literal Offset Mode"** for details.

Words: 1

Cycles: 1

Q Cycle Activity:

Q1	Q2	Q3	Q4
Decode	Read register 'f'	Process Data	Write register 'f'

Example: MOVWF REG, 0

Before Instruction

W = 4Fh
 REG = FFh

After Instruction

W = 4Fh
 REG = 4Fh

PIC18F85J90 FAMILY

MULLW Multiply Literal with W

Syntax: MULLW k

Operands: $0 \leq k \leq 255$

Operation: $(W) \times k \rightarrow \text{PRODH:PRODL}$

Status Affected: None

Encoding:

0000	1101	kkkk	kkkk
------	------	------	------

Description: An unsigned multiplication is carried out between the contents of W and the 8-bit literal 'k'. The 16-bit result is placed in the PRODH:PRODL register pair. PRODH contains the high byte. W is unchanged. None of the Status flags are affected. Note that neither Overflow nor Carry is possible in this operation. A Zero result is possible but not detected.

Words: 1

Cycles: 1

Q Cycle Activity:

Q1	Q2	Q3	Q4
Decode	Read literal 'k'	Process Data	Write registers PRODH:PRODL

Example: MULLW 0C4h

Before Instruction

W = E2h

PRODH = ?

PRODL = ?

After Instruction

W = E2h

PRODH = ADh

PRODL = 08h

MULWF Multiply W with f

Syntax: MULWF f{,a}

Operands: $0 \leq f \leq 255$
 $a \in [0,1]$

Operation: $(W) \times (f) \rightarrow \text{PRODH:PRODL}$

Status Affected: None

Encoding:

0000	001a	ffff	ffff
------	------	------	------

Description: An unsigned multiplication is carried out between the contents of W and the register file location 'f'. The 16-bit result is stored in the PRODH:PRODL register pair. PRODH contains the high byte. Both W and 'f' are unchanged. None of the Status flags are affected. Note that neither Overflow nor Carry is possible in this operation. A Zero result is possible but not detected. If 'a' is '0', the Access Bank is selected. If 'a' is '1', the BSR is used to select the GPR bank (default).

If 'a' is '0' and the extended instruction set is enabled, this instruction operates in Indexed Literal Offset Addressing mode whenever $f \leq 95$ (5Fh). See **Section 23.2.3 "Byte-Oriented and Bit-Oriented Instructions in Indexed Literal Offset Mode"** for details.

Words: 1

Cycles: 1

Q Cycle Activity:

Q1	Q2	Q3	Q4
Decode	Read register 'f'	Process Data	Write registers PRODH:PRODL

Example: MULWF REG, 1

Before Instruction

W = C4h

REG = B5h

PRODH = ?

PRODL = ?

After Instruction

W = C4h

REG = B5h

PRODH = 8Ah

PRODL = 94h

PIC18F85J90 FAMILY

NEGF	Negate f								
Syntax:	NEGF f {,a}								
Operands:	0 ≤ f ≤ 255 a ∈ [0,1]								
Operation:	$\bar{f} + 1 \rightarrow f$								
Status Affected:	N, OV, C, DC, Z								
Encoding:	<table border="1"> <tr> <td>0110</td> <td>110a</td> <td>ffff</td> <td>ffff</td> </tr> </table>	0110	110a	ffff	ffff				
0110	110a	ffff	ffff						
Description:	<p>Location 'f' is negated using two's complement. The result is placed in the data memory location 'f'.</p> <p>If 'a' is '0', the Access Bank is selected. If 'a' is '1', the BSR is used to select the GPR bank (default).</p> <p>If 'a' is '0' and the extended instruction set is enabled, this instruction operates in Indexed Literal Offset Addressing mode whenever f ≤ 95 (5Fh). See Section 23.2.3 "Byte-Oriented and Bit-Oriented Instructions in Indexed Literal Offset Mode" for details.</p>								
Words:	1								
Cycles:	1								
Q Cycle Activity:	<table border="1"> <thead> <tr> <th>Q1</th> <th>Q2</th> <th>Q3</th> <th>Q4</th> </tr> </thead> <tbody> <tr> <td>Decode</td> <td>Read register 'f'</td> <td>Process Data</td> <td>Write register 'f'</td> </tr> </tbody> </table>	Q1	Q2	Q3	Q4	Decode	Read register 'f'	Process Data	Write register 'f'
Q1	Q2	Q3	Q4						
Decode	Read register 'f'	Process Data	Write register 'f'						

Example: NEGF REG, 1

Before Instruction
REG = 0011 1010 [3Ah]
After Instruction
REG = 1100 0110 [C6h]

NOP	No Operation								
Syntax:	NOP								
Operands:	None								
Operation:	No operation								
Status Affected:	None								
Encoding:	<table border="1"> <tr> <td>0000</td> <td>0000</td> <td>0000</td> <td>0000</td> </tr> <tr> <td>1111</td> <td>xxxx</td> <td>xxxx</td> <td>xxxx</td> </tr> </table>	0000	0000	0000	0000	1111	xxxx	xxxx	xxxx
0000	0000	0000	0000						
1111	xxxx	xxxx	xxxx						
Description:	No operation.								
Words:	1								
Cycles:	1								
Q Cycle Activity:	<table border="1"> <thead> <tr> <th>Q1</th> <th>Q2</th> <th>Q3</th> <th>Q4</th> </tr> </thead> <tbody> <tr> <td>Decode</td> <td>No operation</td> <td>No operation</td> <td>No operation</td> </tr> </tbody> </table>	Q1	Q2	Q3	Q4	Decode	No operation	No operation	No operation
Q1	Q2	Q3	Q4						
Decode	No operation	No operation	No operation						

Example:
None.

PIC18F85J90 FAMILY

POP Pop Top of Return Stack

Syntax: POP
 Operands: None
 Operation: (TOS) → bit bucket
 Status Affected: None
 Encoding:

0000	0000	0000	0110
------	------	------	------

 Description: The TOS value is pulled off the return stack and is discarded. The TOS value then becomes the previous value that was pushed onto the return stack. This instruction is provided to enable the user to properly manage the return stack to incorporate a software stack.
 Words: 1
 Cycles: 1

Q Cycle Activity:

Q1	Q2	Q3	Q4
Decode	No operation	POP TOS value	No operation

Example:

	POP		NEW
	GOTO		
Before Instruction			
TOS	=	0031A2h	
Stack (1 level down)	=	014332h	
After Instruction			
TOS	=	014332h	
PC	=	NEW	

PUSH Push Top of Return Stack

Syntax: PUSH
 Operands: None
 Operation: (PC + 2) → TOS
 Status Affected: None
 Encoding:

0000	0000	0000	0101
------	------	------	------

 Description: The PC + 2 is pushed onto the top of the return stack. The previous TOS value is pushed down on the stack. This instruction allows implementing a software stack by modifying TOS and then pushing it onto the return stack.
 Words: 1
 Cycles: 1

Q Cycle Activity:

Q1	Q2	Q3	Q4
Decode	PUSH PC + 2 onto return stack	No operation	No operation

Example:

	PUSH		
Before Instruction			
TOS	=	345Ah	
PC	=	0124h	
After Instruction			
PC	=	0126h	
TOS	=	0126h	
Stack (1 level down)	=	345Ah	

PIC18F85J90 FAMILY

RCALL **Relative Call**

Syntax: RCALL n

Operands: $-1024 \leq n \leq 1023$

Operation: $(PC) + 2 \rightarrow TOS,$
 $(PC) + 2 + 2n \rightarrow PC$

Status Affected: None

Encoding:

1101	1nnn	nnnn	nnnn
------	------	------	------

Description: Subroutine call with a jump up to 1K from the current location. First, return address $(PC + 2)$ is pushed onto the stack. Then, add the 2's complement number '2n' to the PC. Since the PC will have incremented to fetch the next instruction, the new address will be $PC + 2 + 2n$. This instruction is a two-cycle instruction.

Words: 1

Cycles: 2

Q Cycle Activity:

Q1	Q2	Q3	Q4
Decode	Read literal 'n' PUSH PC to stack	Process Data	Write to PC
No operation	No operation	No operation	No operation

Example: HERE RCALL Jump

Before Instruction
PC = Address (HERE)

After Instruction
PC = Address (Jump)
TOS = Address (HERE + 2)

RESET **Reset**

Syntax: RESET

Operands: None

Operation: Reset all registers and flags that are affected by a MCLR Reset.

Status Affected: All

Encoding:

0000	0000	1111	1111
------	------	------	------

Description: This instruction provides a way to execute a MCLR Reset in software.

Words: 1

Cycles: 1

Q Cycle Activity:

Q1	Q2	Q3	Q4
Decode	Start reset	No operation	No operation

Example: RESET

After Instruction
Registers = Reset Value
Flags* = Reset Value

PIC18F85J90 FAMILY

RETFIE Return from Interrupt

Syntax: RETFIE {s}

Operands: s ∈ [0,1]

Operation: (TOS) → PC,
1 → GIE/GIEH or PEIE/GIEL;
if s = 1
(WS) → W,
(STATUS) → STATUS,
(BSRS) → BSR,
PCLATU, PCLATH are unchanged

Status Affected: GIE/GIEH, PEIE/GIEL.

0000	0000	0001	000s
------	------	------	------

Encoding:

Description: Return from interrupt. Stack is popped and Top-of-Stack (TOS) is loaded into the PC. Interrupts are enabled by setting either the high or low priority global interrupt enable bit. If 's' = 1, the contents of the shadow registers WS, STATUS and BSRS are loaded into their corresponding registers W, STATUS and BSR. If 's' = 0, no update of these registers occurs (default).

Words: 1

Cycles: 2

Q Cycle Activity:

Q1	Q2	Q3	Q4
Decode	No operation	No operation	POP PC from stack Set GIEH or GIEL
No operation	No operation	No operation	No operation

Example: RETFIE 1

After Interrupt

PC	=	TOS
W	=	WS
BSR	=	BSRS
STATUS	=	STATUS
GIE/GIEH, PEIE/GIEL	=	1

RETLW Return Literal to W

Syntax: RETLW k

Operands: 0 ≤ k ≤ 255

Operation: k → W,
(TOS) → PC,
PCLATU, PCLATH are unchanged

Status Affected: None

0000	1100	kkkk	kkkk
------	------	------	------

Encoding:

Description: W is loaded with the eight-bit literal 'k'. The program counter is loaded from the top of the stack (the return address). The high address latch (PCLATH) remains unchanged.

Words: 1

Cycles: 2

Q Cycle Activity:

Q1	Q2	Q3	Q4
Decode	Read literal 'k'	Process Data	POP PC from stack, write to W
No operation	No operation	No operation	No operation

Example:

```
CALL TABLE ; W contains table
              ; offset value
              ; W now has
              ; table value
:
TABLE
  ADDWF PCL ; W = offset
  RETLW k0 ; Begin table
  RETLW k1 ;
:
:
  RETLW kn ; End of table
```

Before Instruction
W = 07h

After Instruction
W = value of kn

PIC18F85J90 FAMILY

RETURN **Return from Subroutine**

Syntax: RETURN {s}

Operands: s ∈ [0,1]

Operation: (TOS) → PC;
if s = 1
(WS) → W,
(STATUS) → STATUS,
(BSRS) → BSR,
PCLATU, PCLATH are unchanged

Status Affected: None

Encoding:

0000	0000	0001	001s
------	------	------	------

Description: Return from subroutine. The stack is popped and the top of the stack (TOS) is loaded into the program counter. If 's' = 1, the contents of the shadow registers WS, STATUS and BSRS are loaded into their corresponding registers W, STATUS and BSR. If 's' = 0, no update of these registers occurs (default).

Words: 1

Cycles: 2

Q Cycle Activity:

	Q1	Q2	Q3	Q4
Decode	No operation	Process Data	POP PC from stack	
No operation	No operation	No operation	No operation	

Example: RETURN

After Instruction:
PC = TOS

RLCF **Rotate Left f through Carry**

Syntax: RLCF f {,d {,a}}

Operands: 0 ≤ f ≤ 255
d ∈ [0,1]
a ∈ [0,1]

Operation: (f<n>) → dest<n + 1>,
(f<7>) → C,
(C) → dest<0>

Status Affected: C, N, Z

Encoding:

0011	01da	ffff	ffff
------	------	------	------

Description: The contents of register 'f' are rotated one bit to the left through the Carry flag. If 'd' is '0', the result is placed in W. If 'd' is '1', the result is stored back in register 'f' (default).

If 'a' is '0', the Access Bank is selected. If 'a' is '1', the BSR is used to select the GPR bank (default).

If 'a' is '0' and the extended instruction set is enabled, this instruction operates in Indexed Literal Offset Addressing mode whenever f ≤ 95 (5Fh). See **Section 23.2.3 "Byte-Oriented and Bit-Oriented Instructions in Indexed Literal Offset Mode"** for details.

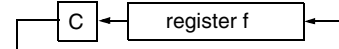

Words: 1

Cycles: 1

Q Cycle Activity:

	Q1	Q2	Q3	Q4
Decode	Read register 'f'	Process Data	Write to destination	

Example: RLCF REG, 0, 0

Before Instruction
REG = 1110 0110
C = 0

After Instruction
REG = 1110 0110
W = 1100 1100
C = 1

PIC18F85J90 FAMILY

RLNCF Rotate Left f (No Carry)

Syntax: RLNCF f {,d {,a}}

Operands: $0 \leq f \leq 255$
 $d \in [0,1]$
 $a \in [0,1]$

Operation: $(f<n>) \rightarrow \text{dest}<n+1>$,
 $(f<7>) \rightarrow \text{dest}<0>$

Status Affected: N, Z

Encoding:

0100	01da	ffff	ffff
------	------	------	------

Description: The contents of register 'f' are rotated one bit to the left. If 'd' is '0', the result is placed in W. If 'd' is '1', the result is stored back in register 'f' (default).
 If 'a' is '0', the Access Bank is selected. If 'a' is '1', the BSR is used to select the GPR bank (default).
 If 'a' is '0' and the extended instruction set is enabled, this instruction operates in Indexed Literal Offset Addressing mode whenever $f \leq 95$ (5Fh). See **Section 23.2.3 "Byte-Oriented and Bit-Oriented Instructions in Indexed Literal Offset Mode"** for details.



Words: 1

Cycles: 1

Q Cycle Activity:

Q1	Q2	Q3	Q4
Decode	Read register 'f'	Process Data	Write to destination

Example: RLNCF REG, 1, 0

Before Instruction
 REG = 1010 1011
 After Instruction
 REG = 0101 0111

RRCF Rotate Right f through Carry

Syntax: RRCF f {,d {,a}}

Operands: $0 \leq f \leq 255$
 $d \in [0,1]$
 $a \in [0,1]$

Operation: $(f<n>) \rightarrow \text{dest}<n-1>$,
 $(f<0>) \rightarrow C$,
 $(C) \rightarrow \text{dest}<7>$

Status Affected: C, N, Z

Encoding:

0011	00da	ffff	ffff
------	------	------	------

Description: The contents of register 'f' are rotated one bit to the right through the Carry flag. If 'd' is '0', the result is placed in W. If 'd' is '1', the result is placed back in register 'f' (default).
 If 'a' is '0', the Access Bank is selected. If 'a' is '1', the BSR is used to select the GPR bank (default).
 If 'a' is '0' and the extended instruction set is enabled, this instruction operates in Indexed Literal Offset Addressing mode whenever $f \leq 95$ (5Fh). See **Section 23.2.3 "Byte-Oriented and Bit-Oriented Instructions in Indexed Literal Offset Mode"** for details.

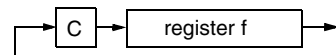

Words: 1

Cycles: 1

Q Cycle Activity:

Q1	Q2	Q3	Q4
Decode	Read register 'f'	Process Data	Write to destination

Example: RRCF REG, 0, 0

Before Instruction
 REG = 1110 0110
 C = 0
 After Instruction
 REG = 1110 0110
 W = 0111 0011
 C = 0

PIC18F85J90 FAMILY

RRNCF Rotate Right f (No Carry)

Syntax: RRNCF f {,d {,a}}

Operands: $0 \leq f \leq 255$
 $d \in [0,1]$
 $a \in [0,1]$

Operation: $(f\langle n \rangle) \rightarrow \text{dest}\langle n-1 \rangle$,
 $(f\langle 0 \rangle) \rightarrow \text{dest}\langle 7 \rangle$

Status Affected: N, Z

Encoding:

0100	00da	ffff	ffff
------	------	------	------

Description: The contents of register 'f' are rotated one bit to the right. If 'd' is '0', the result is placed in W. If 'd' is '1', the result is placed back in register 'f' (default).

If 'a' is '0', the Access Bank will be selected, overriding the BSR value. If 'a' is '1', then the bank will be selected as per the BSR value (default).

If 'a' is '0' and the extended instruction set is enabled, this instruction operates in Indexed Literal Offset Addressing mode whenever $f \leq 95$ (5Fh). See **Section 23.2.3 "Byte-Oriented and Bit-Oriented Instructions in Indexed Literal Offset Mode"** for details.



Words: 1
Cycles: 1

Q Cycle Activity:

Q1	Q2	Q3	Q4
Decode	Read register 'f'	Process Data	Write to destination

Example 1: RRNCF REG, 1, 0

Before Instruction
REG = 1101 0111
After Instruction
REG = 1110 1011

Example 2: RRNCF REG, 0, 0

Before Instruction
W = ?
REG = 1101 0111
After Instruction
W = 1110 1011
REG = 1101 0111

SETF Set f

Syntax: SETF f {,a}

Operands: $0 \leq f \leq 255$
 $a \in [0,1]$

Operation: $\text{FFh} \rightarrow f$

Status Affected: None

Encoding:

0110	100a	ffff	ffff
------	------	------	------

Description: The contents of the specified register are set to FFh.

If 'a' is '0', the Access Bank is selected. If 'a' is '1', the BSR is used to select the GPR bank (default).

If 'a' is '0' and the extended instruction set is enabled, this instruction operates in Indexed Literal Offset Addressing mode whenever $f \leq 95$ (5Fh). See **Section 23.2.3 "Byte-Oriented and Bit-Oriented Instructions in Indexed Literal Offset Mode"** for details.

Words: 1
Cycles: 1

Q Cycle Activity:

Q1	Q2	Q3	Q4
Decode	Read register 'f'	Process Data	Write register 'f'

Example: SETF REG, 1

Before Instruction
REG = 5Ah
After Instruction
REG = FFh

PIC18F85J90 FAMILY

SLEEP	Enter Sleep Mode								
Syntax:	SLEEP								
Operands:	None								
Operation:	00h → WDT, 0 → WDT postscaler, 1 → \overline{TO} , 0 → PD								
Status Affected:	\overline{TO} , \overline{PD}								
Encoding:	<table border="1" style="display: inline-table; border-collapse: collapse;"> <tr> <td style="width: 25px; text-align: center;">0000</td> <td style="width: 25px; text-align: center;">0000</td> <td style="width: 25px; text-align: center;">0000</td> <td style="width: 25px; text-align: center;">0011</td> </tr> </table>	0000	0000	0000	0011				
0000	0000	0000	0011						
Description:	The Power-Down status bit (\overline{PD}) is cleared. The Time-out status bit (\overline{TO}) is set. The Watchdog Timer and its postscaler are cleared. The processor is put into Sleep mode with the oscillator stopped.								
Words:	1								
Cycles:	1								
Q Cycle Activity:	<table border="1" style="display: inline-table; border-collapse: collapse; text-align: center;"> <tr> <td style="width: 25px;">Q1</td> <td style="width: 25px;">Q2</td> <td style="width: 25px;">Q3</td> <td style="width: 25px;">Q4</td> </tr> <tr> <td>Decode</td> <td>No operation</td> <td>Process Data</td> <td>Go to Sleep</td> </tr> </table>	Q1	Q2	Q3	Q4	Decode	No operation	Process Data	Go to Sleep
Q1	Q2	Q3	Q4						
Decode	No operation	Process Data	Go to Sleep						

Example: SLEEP

Before Instruction

\overline{TO} = ?
 \overline{PD} = ?

After Instruction

\overline{TO} = 1 †
 \overline{PD} = 0

† If WDT causes wake-up, this bit is cleared.

SUBFWB	Subtract f from W with Borrow								
Syntax:	SUBFWB f {,d {,a}}								
Operands:	$0 \leq f \leq 255$ $d \in [0,1]$ $a \in [0,1]$								
Operation:	$(W) - (f) - (\overline{C}) \rightarrow \text{dest}$								
Status Affected:	N, OV, C, DC, Z								
Encoding:	<table border="1" style="display: inline-table; border-collapse: collapse;"> <tr> <td style="width: 25px; text-align: center;">0101</td> <td style="width: 25px; text-align: center;">01da</td> <td style="width: 25px; text-align: center;">ffff</td> <td style="width: 25px; text-align: center;">ffff</td> </tr> </table>	0101	01da	ffff	ffff				
0101	01da	ffff	ffff						
Description:	Subtract register 'f' and Carry flag (borrow) from W (2's complement method). If 'd' is '0', the result is stored in W. If 'd' is '1', the result is stored in register 'f' (default). If 'a' is '0', the Access Bank is selected. If 'a' is '1', the BSR is used to select the GPR bank (default). If 'a' is '0' and the extended instruction set is enabled, this instruction operates in Indexed Literal Offset Addressing mode whenever $f \leq 95$ (5Fh). See Section 23.2.3 "Byte-Oriented and Bit-Oriented Instructions in Indexed Literal Offset Mode" for details.								
Words:	1								
Cycles:	1								
Q Cycle Activity:	<table border="1" style="display: inline-table; border-collapse: collapse; text-align: center;"> <tr> <td style="width: 25px;">Q1</td> <td style="width: 25px;">Q2</td> <td style="width: 25px;">Q3</td> <td style="width: 25px;">Q4</td> </tr> <tr> <td>Decode</td> <td>Read register 'f'</td> <td>Process Data</td> <td>Write to destination</td> </tr> </table>	Q1	Q2	Q3	Q4	Decode	Read register 'f'	Process Data	Write to destination
Q1	Q2	Q3	Q4						
Decode	Read register 'f'	Process Data	Write to destination						

Example 1: SUBFWB REG, 1, 0

Before Instruction

REG = 3
W = 2
C = 1

After Instruction

REG = FF
W = 2
C = 0
Z = 0
N = 1 ; result is negative

Example 2: SUBFWB REG, 0, 0

Before Instruction

REG = 2
W = 5
C = 1

After Instruction

REG = 2
W = 3
C = 1
Z = 0
N = 0 ; result is positive

Example 3: SUBFWB REG, 1, 0

Before Instruction

REG = 1
W = 2
C = 0

After Instruction

REG = 0
W = 2
C = 1
Z = 1 ; result is zero
N = 0

PIC18F85J90 FAMILY

SUBLW Subtract W from Literal

Syntax: SUBLW k
 Operands: $0 \leq k \leq 255$
 Operation: $k - (W) \rightarrow W$
 Status Affected: N, OV, C, DC, Z
 Encoding:

0000	1000	kkkk	kkkk
------	------	------	------

 Description: W is subtracted from the eight-bit literal 'k'. The result is placed in W.
 Words: 1
 Cycles: 1
 Q Cycle Activity:

Q1	Q2	Q3	Q4
Decode	Read literal 'k'	Process Data	Write to W

Example 1: SUBLW 02h
 Before Instruction
 W = 01h
 C = ?
 After Instruction
 W = 01h
 C = 1 ; result is positive
 Z = 0
 N = 0

Example 2: SUBLW 02h
 Before Instruction
 W = 02h
 C = ?
 After Instruction
 W = 00h
 C = 1 ; result is zero
 Z = 1
 N = 0

Example 3: SUBLW 02h
 Before Instruction
 W = 03h
 C = ?
 After Instruction
 W = FFh ; (2's complement)
 C = 0 ; result is negative
 Z = 0
 N = 1

SUBWF Subtract W from f

Syntax: SUBWF f {,d {,a}}
 Operands: $0 \leq f \leq 255$
 $d \in [0,1]$
 $a \in [0,1]$
 Operation: $(f) - (W) \rightarrow \text{dest}$
 Status Affected: N, OV, C, DC, Z
 Encoding:

0101	11da	ffff	ffff
------	------	------	------

 Description: Subtract W from register 'f' (2's complement method). If 'd' is '0', the result is stored in W. If 'd' is '1', the result is stored back in register 'f' (default).

If 'a' is '0', the Access Bank is selected. If 'a' is '1', the BSR is used to select the GPR bank (default).

If 'a' is '0' and the extended instruction set is enabled, this instruction operates in Indexed Literal Offset Addressing mode whenever $f \leq 95$ (5Fh). See **Section 23.2.3 "Byte-Oriented and Bit-Oriented Instructions in Indexed Literal Offset Mode"** for details.

Words: 1
 Cycles: 1
 Q Cycle Activity:

Q1	Q2	Q3	Q4
Decode	Read register 'f'	Process Data	Write to destination

Example 1: SUBWF REG, 1, 0
 Before Instruction
 REG = 3
 W = 2
 C = ?
 After Instruction
 REG = 1
 W = 2
 C = 1 ; result is positive
 Z = 0
 N = 0

Example 2: SUBWF REG, 0, 0
 Before Instruction
 REG = 2
 W = 2
 C = ?
 After Instruction
 REG = 2
 W = 0
 C = 1 ; result is zero
 Z = 1
 N = 0

Example 3: SUBWF REG, 1, 0
 Before Instruction
 REG = 1
 W = 2
 C = ?
 After Instruction
 REG = FFh ; (2's complement)
 W = 2
 C = 0 ; result is negative
 Z = 0
 N = 1

PIC18F85J90 FAMILY

SUBWFB **Subtract W from f with Borrow**

Syntax: SUBWFB f{,d{,a}}

Operands: $0 \leq f \leq 255$
 $d \in [0,1]$
 $a \in [0,1]$

Operation: $(f) - (W) - (\overline{C}) \rightarrow \text{dest}$

Status Affected: N, OV, C, DC, Z

Encoding:

0101	10da	ffff	ffff
------	------	------	------

Description: Subtract W and the Carry flag (borrow) from register 'f' (2's complement method). If 'd' is '0', the result is stored in W. If 'd' is '1', the result is stored back in register 'f' (default).

 If 'a' is '0', the Access Bank is selected. If 'a' is '1', the BSR is used to select the GPR bank (default).

 If 'a' is '0' and the extended instruction set is enabled, this instruction operates in Indexed Literal Offset Addressing mode whenever $f \leq 95$ (5Fh). See **Section 23.2.3 "Byte-Oriented and Bit-Oriented Instructions in Indexed Literal Offset Mode"** for details.

Words: 1

Cycles: 1

Q Cycle Activity:

Q1	Q2	Q3	Q4
Decode	Read register 'f'	Process Data	Write to destination

Example 1: SUBWFB REG, 1, 0

Before Instruction

REG = 19h (0001 1001)

W = 0Dh (0000 1101)

C = 1

After Instruction

REG = 0Ch (0000 1011)

W = 0Dh (0000 1101)

C = 1

Z = 0

N = 0 ; result is positive

Example 2: SUBWFB REG, 0, 0

Before Instruction

REG = 1Bh (0001 1011)

W = 1Ah (0001 1010)

C = 0

After Instruction

REG = 1Bh (0001 1011)

W = 00h

C = 1

Z = 1 ; result is zero

N = 0

Example 3: SUBWFB REG, 1, 0

Before Instruction

REG = 03h (0000 0011)

W = 0Eh (0000 1101)

C = 1

After Instruction

REG = F5h (1111 0100)
 ; [2's comp]

W = 0Eh (0000 1101)

C = 0

Z = 0

N = 1 ; result is negative

SWAPF **Swap f**

Syntax: SWAPF f{,d{,a}}

Operands: $0 \leq f \leq 255$
 $d \in [0,1]$
 $a \in [0,1]$

Operation: $(f<3:0>) \rightarrow \text{dest}<7:4>$,
 $(f<7:4>) \rightarrow \text{dest}<3:0>$

Status Affected: None

Encoding:

0011	10da	ffff	ffff
------	------	------	------

Description: The upper and lower nibbles of register 'f' are exchanged. If 'd' is '0', the result is placed in W. If 'd' is '1', the result is placed in register 'f' (default).

 If 'a' is '0', the Access Bank is selected. If 'a' is '1', the BSR is used to select the GPR bank (default).

 If 'a' is '0' and the extended instruction set is enabled, this instruction operates in Indexed Literal Offset Addressing mode whenever $f \leq 95$ (5Fh). See **Section 23.2.3 "Byte-Oriented and Bit-Oriented Instructions in Indexed Literal Offset Mode"** for details.

Words: 1

Cycles: 1

Q Cycle Activity:

Q1	Q2	Q3	Q4
Decode	Read register 'f'	Process Data	Write to destination

Example: SWAPF REG, 1, 0

Before Instruction

REG = 53h

After Instruction

REG = 35h

PIC18F85J90 FAMILY

TBLRD Table Read

Syntax: TBLRD (*; *+; *-; +*)

Operands: None

Operation: if TBLRD *,
 (Program Mem (TBLPTR)) → TABLAT;
 TBLPTR – No Change
 if TBLRD *+,
 (Program Mem (TBLPTR)) → TABLAT;
 (TBLPTR) + 1 → TBLPTR
 if TBLRD *-,
 (Program Mem (TBLPTR)) → TABLAT;
 (TBLPTR) – 1 → TBLPTR
 if TBLRD +*,
 (TBLPTR) + 1 → TBLPTR;
 (Program Mem (TBLPTR)) → TABLAT

Status Affected: None

Encoding:

0000	0000	0000	10nn nn=0 * =1 *+ =2 *- =3 +*
------	------	------	-------------------------------------------

Description: This instruction is used to read the contents of Program Memory (P.M.). To address the program memory, a pointer called Table Pointer (TBLPTR) is used.

The TBLPTR (a 21-bit pointer) points to each byte in the program memory. TBLPTR has a 2-Mbyte address range.

TBLPTR[0] = 0: Least Significant Byte of Program Memory Word

TBLPTR[0] = 1: Most Significant Byte of Program Memory Word

The TBLRD instruction can modify the value of TBLPTR as follows:

- no change
- post-increment
- post-decrement
- pre-increment

Words: 1

Cycles: 2

Q Cycle Activity:

	Q1	Q2	Q3	Q4
Decode	No operation	No operation	No operation	No operation
No operation	No operation (Read Program Memory)	No operation	No operation (Write TABLAT)	

TBLRD Table Read (Continued)

Example 1: TBLRD *+ ;

Before Instruction

TABLAT	=	55h
TBLPTR	=	00A356h
MEMORY(00A356h)	=	34h

After Instruction

TABLAT	=	34h
TBLPTR	=	00A357h

Example 2: TBLRD +* ;

Before Instruction

TABLAT	=	AAh
TBLPTR	=	01A357h
MEMORY(01A357h)	=	12h
MEMORY(01A358h)	=	34h

After Instruction

TABLAT	=	34h
TBLPTR	=	01A358h

PIC18F85J90 FAMILY

TBLWT Table Write

Syntax: TBLWT (*; *+; *-; +*)

Operands: None

Operation: if TBLWT*,
(TABLAT) → Holding Register;
TBLPTR – No Change
if TBLWT*+,
(TABLAT) → Holding Register;
(TBLPTR) + 1 → TBLPTR
if TBLWT*-,
(TABLAT) → Holding Register;
(TBLPTR) – 1 → TBLPTR
if TBLWT*+*,
(TBLPTR) + 1 → TBLPTR;
(TABLAT) → Holding Register

Status Affected: None

Encoding:

0000	0000	0000	11nn nn=0 * =1 *+ =2 *- =3 +*
------	------	------	-------------------------------------------

Description: This instruction uses the 3 LSBs of TBLPTR to determine which of the 8 holding registers the TABLAT is written to. The holding registers are used to program the contents of Program Memory (P.M.). (Refer to **Section 5.0 “Memory Organization”** for additional details on programming Flash memory.)

The TBLPTR (a 21-bit pointer) points to each byte in the program memory. TBLPTR has a 2-Mbyte address range. The LSb of the TBLPTR selects which byte of the program memory location to access.

TBLPTR[0] = 0: Least Significant Byte of Program Memory Word

TBLPTR[0] = 1: Most Significant Byte of Program Memory Word

The TBLWT instruction can modify the value of TBLPTR as follows:

- no change
- post-increment
- post-decrement
- pre-increment

Words: 1

Cycles: 2

Q Cycle Activity:

	Q1	Q2	Q3	Q4
Decode	No operation	No operation	No operation	No operation
No operation	No operation (Read TABLAT)	No operation	No operation	No operation (Write to Holding Register)

TBLWT Table Write (Continued)

Example 1: TBLWT *+;

Before Instruction

TABLAT	=	55h
TBLPTR	=	00A356h
HOLDING REGISTER (00A356h)	=	FFh

After Instructions (table write completion)

TABLAT	=	55h
TBLPTR	=	00A357h
HOLDING REGISTER (00A356h)	=	55h

Example 2: TBLWT +*;

Before Instruction

TABLAT	=	34h
TBLPTR	=	01389Ah
HOLDING REGISTER (01389Ah)	=	FFh
HOLDING REGISTER (01389Bh)	=	FFh

After Instruction (table write completion)

TABLAT	=	34h
TBLPTR	=	01389Bh
HOLDING REGISTER (01389Ah)	=	FFh
HOLDING REGISTER (01389Bh)	=	34h

PIC18F85J90 FAMILY

TSTFSZ **Test f, Skip if 0**

Syntax: TSTFSZ f {,a}

Operands: $0 \leq f \leq 255$
 $a \in [0,1]$

Operation: skip if $f = 0$

Status Affected: None

Encoding:

0110	011a	ffff	ffff
------	------	------	------

Description: If 'f' = 0, the next instruction fetched during the current instruction execution is discarded and a NOP is executed, making this a two-cycle instruction.

 If 'a' is '0', the Access Bank is selected. If 'a' is '1', the BSR is used to select the GPR bank (default).

 If 'a' is '0' and the extended instruction set is enabled, this instruction operates in Indexed Literal Offset Addressing mode whenever $f \leq 95$ (5Fh). See **Section 23.2.3 "Byte-Oriented and Bit-Oriented Instructions in Indexed Literal Offset Mode"** for details.

Words: 1

Cycles: 1(2)

Note: 3 cycles if skip and followed by a 2-word instruction.

Q Cycle Activity:

Q1	Q2	Q3	Q4
Decode	Read register 'f'	Process Data	No operation

If skip:

Q1	Q2	Q3	Q4
No operation	No operation	No operation	No operation

If skip and followed by 2-word instruction:

Q1	Q2	Q3	Q4
No operation	No operation	No operation	No operation
No operation	No operation	No operation	No operation

Example:

```

HERE     TSTFSZ   CNT, 1
NZERO    :
ZERO     :
```

Before Instruction
PC = Address (HERE)

After Instruction
If CNT = 00h,
PC = Address (ZERO)
If CNT ≠ 00h,
PC = Address (NZERO)

XORLW **Exclusive OR Literal with W**

Syntax: XORLW k

Operands: $0 \leq k \leq 255$

Operation: (W) .XOR. k → W

Status Affected: N, Z

Encoding:

0000	1010	kkkk	kkkk
------	------	------	------

Description: The contents of W are XORed with the 8-bit literal 'k'. The result is placed in W.

Words: 1

Cycles: 1

Q Cycle Activity:

Q1	Q2	Q3	Q4
Decode	Read literal 'k'	Process Data	Write to W

Example:

```

XORLW    0AFh

Before Instruction
W        =    B5h
After Instruction
W        =    1Ah
```

PIC18F85J90 FAMILY

XORWF Exclusive OR W with f

Syntax: XORWF f {,d {,a}}

Operands: $0 \leq f \leq 255$
 $d \in [0,1]$
 $a \in [0,1]$

Operation: (W) .XOR. (f) → dest

Status Affected: N, Z

Encoding:

0001	10da	ffff	ffff
------	------	------	------

Description: Exclusive OR the contents of W with register 'f'. If 'd' is '0', the result is stored in W. If 'd' is '1', the result is stored back in the register 'f' (default).

If 'a' is '0', the Access Bank is selected.
If 'a' is '1', the BSR is used to select the GPR bank (default).

If 'a' is '0' and the extended instruction set is enabled, this instruction operates in Indexed Literal Offset Addressing mode whenever $f \leq 95$ (5Fh). See **Section 23.2.3 "Byte-Oriented and Bit-Oriented Instructions in Indexed Literal Offset Mode"** for details.

Words: 1

Cycles: 1

Q Cycle Activity:

Q1	Q2	Q3	Q4
Decode	Read register 'f'	Process Data	Write to destination

Example: XORWF REG, 1, 0

Before Instruction

REG = AFh
W = B5h

After Instruction

REG = 1Ah
W = B5h

23.2 Extended Instruction Set

In addition to the standard 75 instructions of the PIC18 instruction set, the PIC18F85J90 family of devices also provide an optional extension to the core CPU functionality. The added features include eight additional instructions that augment Indirect and Indexed Addressing operations and the implementation of Indexed Literal Offset Addressing for many of the standard PIC18 instructions.

The additional features of the extended instruction set are enabled by default on unprogrammed devices. Users must properly set or clear the XINST Configuration bit during programming to enable or disable these features.

The instructions in the extended set can all be classified as literal operations, which either manipulate the File Select Registers, or use them for Indexed Addressing. Two of the instructions, `ADDFSR` and `SUBFSR`, each have an additional special instantiation for using FSR2. These versions (`ADDULNK` and `SUBULNK`) allow for automatic return after execution.

The extended instructions are specifically implemented to optimize re-entrant program code (that is, code that is recursive or that uses a software stack) written in high-level languages, particularly C. Among other things, they allow users working in high-level languages to perform certain operations on data structures more efficiently. These include:

- Dynamic allocation and deallocation of software stack space when entering and leaving subroutines
- Function Pointer invocation
- Software Stack Pointer manipulation
- Manipulation of variables located in a software stack

A summary of the instructions in the extended instruction set is provided in Table 23-3. Detailed descriptions are provided in **Section 23.2.2 “Extended Instruction Set”**. The opcode field descriptions in Table 23-1 (page 296) apply to both the standard and extended PIC18 instruction sets.

Note: The instruction set extension and the Indexed Literal Offset Addressing mode were designed for optimizing applications written in C; the user may likely never use these instructions directly in assembler. The syntax for these commands is provided as a reference for users who may be reviewing code that has been generated by a compiler.

23.2.1 EXTENDED INSTRUCTION SYNTAX

Most of the extended instructions use indexed arguments, using one of the File Select Registers and some offset to specify a source or destination register. When an argument for an instruction serves as part of Indexed Addressing, it is enclosed in square brackets (“[]”). This is done to indicate that the argument is used as an index or offset. The MPASM™ Assembler will flag an error if it determines that an index or offset value is not bracketed.

When the extended instruction set is enabled, brackets are also used to indicate index arguments in byte-oriented and bit-oriented instructions. This is in addition to other changes in their syntax. For more details, see **Section 23.2.3.1 “Extended Instruction Syntax with Standard PIC18 Commands”**.

Note: In the past, square brackets have been used to denote optional arguments in the PIC18 and earlier instruction sets. In this text and going forward, optional arguments are denoted by braces (“{ }”).

TABLE 23-3: EXTENSIONS TO THE PIC18 INSTRUCTION SET

Mnemonic, Operands	Description	Cycles	16-Bit Instruction Word				Status Affected
			MSb			LSb	
<code>ADDFSR</code> f, k	Add literal to FSR	1	1110	1000	ffkk	kkkk	None
<code>ADDULNK</code> k	Add literal to FSR2 and return	2	1110	1000	11kk	kkkk	None
<code>CALLW</code>	Call subroutine using WREG	2	0000	0000	0001	0100	None
<code>MOVSF</code> z _s , f _d	Move z _s (source) to 1st word f _d (destination) 2nd word	2	1110	1011	0zzz	zzzz	None
<code>MOVSS</code> z _s , z _d	Move z _s (source) to 1st word z _d (destination) 2nd word	2	1110	1011	1zzz	zzzz	None
<code>PUSHL</code> k	Store literal at FSR2, decrement FSR2	1	1110	1010	kkkk	kkkk	None
<code>SUBFSR</code> f, k	Subtract literal from FSR	1	1110	1001	ffkk	kkkk	None
<code>SUBULNK</code> k	Subtract literal from FSR2 and return	2	1110	1001	11kk	kkkk	None

PIC18F85J90 FAMILY

23.2.2 EXTENDED INSTRUCTION SET

ADDFSR Add Literal to FSR

Syntax:	ADDFSR f, k								
Operands:	0 ≤ k ≤ 63 f ∈ [0, 1, 2]								
Operation:	FSR(f) + k → FSR(f)								
Status Affected:	None								
Encoding:	<table border="1" style="display: inline-table; border-collapse: collapse;"><tr><td style="padding: 2px;">1110</td><td style="padding: 2px;">1000</td><td style="padding: 2px;">ffkk</td><td style="padding: 2px;">kkkk</td></tr></table>	1110	1000	ffkk	kkkk				
1110	1000	ffkk	kkkk						
Description:	The 6-bit literal 'k' is added to the contents of the FSR specified by 'f'.								
Words:	1								
Cycles:	1								
Q Cycle Activity:									
	<table border="1" style="display: inline-table; border-collapse: collapse; margin: 0 auto;"><tr><th style="padding: 2px;">Q1</th><th style="padding: 2px;">Q2</th><th style="padding: 2px;">Q3</th><th style="padding: 2px;">Q4</th></tr><tr><td style="padding: 2px;">Decode</td><td style="padding: 2px;">Read literal 'k'</td><td style="padding: 2px;">Process Data</td><td style="padding: 2px;">Write to FSR</td></tr></table>	Q1	Q2	Q3	Q4	Decode	Read literal 'k'	Process Data	Write to FSR
Q1	Q2	Q3	Q4						
Decode	Read literal 'k'	Process Data	Write to FSR						

Example: ADDFSR 2, 23h

Before Instruction
 FSR2 = 03FFh
 After Instruction
 FSR2 = 0422h

ADDLNK Add Literal to FSR2 and Return

Syntax:	ADDLNK k												
Operands:	0 ≤ k ≤ 63												
Operation:	FSR2 + k → FSR2, (TOS) → PC												
Status Affected:	None												
Encoding:	<table border="1" style="display: inline-table; border-collapse: collapse;"><tr><td style="padding: 2px;">1110</td><td style="padding: 2px;">1000</td><td style="padding: 2px;">11kk</td><td style="padding: 2px;">kkkk</td></tr></table>	1110	1000	11kk	kkkk								
1110	1000	11kk	kkkk										
Description:	The 6-bit literal 'k' is added to the contents of FSR2. A RETURN is then executed by loading the PC with the TOS. The instruction takes two cycles to execute; a NOP is performed during the second cycle. This may be thought of as a special case of the ADDFSR instruction, where f = 3 (binary '11'); it operates only on FSR2.												
Words:	1												
Cycles:	2												
Q Cycle Activity:													
	<table border="1" style="display: inline-table; border-collapse: collapse; margin: 0 auto;"><tr><th style="padding: 2px;">Q1</th><th style="padding: 2px;">Q2</th><th style="padding: 2px;">Q3</th><th style="padding: 2px;">Q4</th></tr><tr><td style="padding: 2px;">Decode</td><td style="padding: 2px;">Read literal 'k'</td><td style="padding: 2px;">Process Data</td><td style="padding: 2px;">Write to FSR</td></tr><tr><td style="padding: 2px;">No Operation</td><td style="padding: 2px;">No Operation</td><td style="padding: 2px;">No Operation</td><td style="padding: 2px;">No Operation</td></tr></table>	Q1	Q2	Q3	Q4	Decode	Read literal 'k'	Process Data	Write to FSR	No Operation	No Operation	No Operation	No Operation
Q1	Q2	Q3	Q4										
Decode	Read literal 'k'	Process Data	Write to FSR										
No Operation	No Operation	No Operation	No Operation										

Example: ADDLNK 23h

Before Instruction
 FSR2 = 03FFh
 PC = 0100h
 After Instruction
 FSR2 = 0422h
 PC = (TOS)

Note: All PIC18 instructions may take an optional label argument preceding the instruction mnemonic for use in symbolic addressing. If a label is used, the instruction format then becomes: {label} instruction argument(s).

PIC18F85J90 FAMILY

CALLW Subroutine Call Using WREG

Syntax: CALLW

Operands: None

Operation: (PC + 2) → TOS,
(W) → PCL,
(PCLATH) → PCH,
(PCLATU) → PCU

Status Affected: None

Encoding:

0000	0000	0001	0100
------	------	------	------

Description First, the return address (PC + 2) is pushed onto the return stack. Next, the contents of W are written to PCL; the existing value is discarded. Then, the contents of PCLATH and PCLATU are latched into PCH and PCU, respectively. The second cycle is executed as a NOP instruction while the new next instruction is fetched.

Unlike CALL, there is no option to update W, STATUS or BSR.

Words: 1

Cycles: 2

Q Cycle Activity:

	Q1	Q2	Q3	Q4
Decode	Read WREG	Push PC to stack	No operation	
No operation	No operation	No operation	No operation	

Example: HERE CALLW

Before Instruction

PC = address (HERE)
PCLATH = 10h
PCLATU = 00h
W = 06h

After Instruction

PC = 001006h
TOS = address (HERE + 2)
PCLATH = 10h
PCLATU = 00h
W = 06h

MOVSF Move Indexed to f

Syntax: MOVSF [z_s], f_d

Operands: 0 ≤ z_s ≤ 127
0 ≤ f_d ≤ 4095

Operation: ((FSR2) + z_s) → f_d

Status Affected: None

Encoding:

1110	1011	0zzz	zzzz _s
1111	ffff	ffff	ffff _d

Description: The contents of the source register are moved to destination register 'f_d'. The actual address of the source register is determined by adding the 7-bit literal offset 'z_s', in the first word, to the value of FSR2. The address of the destination register is specified by the 12-bit literal 'f_d' in the second word. Both addresses can be anywhere in the 4096-byte data space (000h to FFFh).

The MOVSF instruction cannot use the PCL, TOSU, TOSH or TOSL as the destination register.

If the resultant source address points to an Indirect Addressing register, the value returned will be 00h.

Words: 2

Cycles: 2

Q Cycle Activity:

Words: 2

Cycles: 2

Q Cycle Activity:

	Q1	Q2	Q3	Q4
Decode	Determine source addr	Determine source addr	Read source reg	
Decode	No operation No dummy read	No operation	Write register 'f' (dest)	

Example: MOVSF [05h], REG2

Before Instruction

FSR2 = 80h
Contents of 85h = 33h
REG2 = 11h

After Instruction

FSR2 = 80h
Contents of 85h = 33h
REG2 = 33h

PIC18F85J90 FAMILY

MOVSS Move Indexed to Indexed

Syntax: MOVSS [z_s], [z_d]

Operands: $0 \leq z_s \leq 127$
 $0 \leq z_d \leq 127$

Operation: $((FSR2) + z_s) \rightarrow ((FSR2) + z_d)$

Status Affected: None

Encoding:

1110	1011	1zzz	zzzz _s
1111	xxxx	xzzz	zzzz _d

1st word (source)
2nd word (dest.)

Description

The contents of the source register are moved to the destination register. The addresses of the source and destination registers are determined by adding the 7-bit literal offsets, ' z_s ' or ' z_d ', respectively, to the value of FSR2. Both registers can be located anywhere in the 4096-byte data memory space (000h to FFFh).

The MOVSS instruction cannot use the PCL, TOSU, TOSH or TOSL as the destination register.

If the resultant source address points to an Indirect Addressing register, the value returned will be 00h. If the resultant destination address points to an Indirect Addressing register, the instruction will execute as a NOP.

Words: 2
Cycles: 2

Q Cycle Activity:

Q1	Q2	Q3	Q4
Decode	Determine source addr	Determine source addr	Read source reg
Decode	Determine dest addr	Determine dest addr	Write to dest reg

Example: MOVSS [05h], [06h]

Before Instruction

FSR2 = 80h
 Contents of 85h = 33h
 Contents of 86h = 11h

After Instruction

FSR2 = 80h
 Contents of 85h = 33h
 Contents of 86h = 33h

PUSHL Store Literal at FSR2, Decrement FSR2

Syntax: PUSHL k

Operands: $0 \leq k \leq 255$

Operation: $k \rightarrow (FSR2)$,
 $FSR2 - 1 \rightarrow FSR2$

Status Affected: None

Encoding:

1111	1010	kkkk	kkkk
------	------	------	------

Description:

The 8-bit literal 'k' is written to the data memory address specified by FSR2. FSR2 is decremented by 1 after the operation.

This instruction allows users to push values onto a software stack.

Words: 1
Cycles: 1

Q Cycle Activity:

Q1	Q2	Q3	Q4
Decode	Read 'k'	Process data	Write to destination

Example: PUSHL 08h

Before Instruction

FSR2H:FSR2L = 01ECh
 Memory (01ECh) = 00h

After Instruction

FSR2H:FSR2L = 01EBh
 Memory (01ECh) = 08h

PIC18F85J90 FAMILY

SUBFSR	Subtract Literal from FSR								
Syntax:	SUBFSR f, k								
Operands:	$0 \leq k \leq 63$ $f \in [0, 1, 2]$								
Operation:	$FSRf - k \rightarrow FSRf$								
Status Affected:	None								
Encoding:	<table border="1" style="display: inline-table;"><tr><td>1110</td><td>1001</td><td>ffkk</td><td>kkkk</td></tr></table>	1110	1001	ffkk	kkkk				
1110	1001	ffkk	kkkk						
Description:	The 6-bit literal 'k' is subtracted from the contents of the FSR specified by 'f'.								
Words:	1								
Cycles:	1								
Q Cycle Activity:	<table border="1" style="display: inline-table;"><thead><tr><th>Q1</th><th>Q2</th><th>Q3</th><th>Q4</th></tr></thead><tbody><tr><td>Decode</td><td>Read register 'f'</td><td>Process Data</td><td>Write to destination</td></tr></tbody></table>	Q1	Q2	Q3	Q4	Decode	Read register 'f'	Process Data	Write to destination
Q1	Q2	Q3	Q4						
Decode	Read register 'f'	Process Data	Write to destination						

Example: SUBFSR 2, 23h

Before Instruction
FSR2 = 03FFh

After Instruction
FSR2 = 03DCh

SUBULNK	Subtract Literal from FSR2 and Return												
Syntax:	SUBULNK k												
Operands:	$0 \leq k \leq 63$												
Operation:	$FSR2 - k \rightarrow FSR2$, (TOS) \rightarrow PC												
Status Affected:	None												
Encoding:	<table border="1" style="display: inline-table;"><tr><td>1110</td><td>1001</td><td>11kk</td><td>kkkk</td></tr></table>	1110	1001	11kk	kkkk								
1110	1001	11kk	kkkk										
Description:	The 6-bit literal 'k' is subtracted from the contents of the FSR2. A RETURN is then executed by loading the PC with the TOS. The instruction takes two cycles to execute; a NOP is performed during the second cycle. This may be thought of as a special case of the SUBFSR instruction, where $f = 3$ (binary '11'); it operates only on FSR2.												
Words:	1												
Cycles:	2												
Q Cycle Activity:	<table border="1" style="display: inline-table;"><thead><tr><th>Q1</th><th>Q2</th><th>Q3</th><th>Q4</th></tr></thead><tbody><tr><td>Decode</td><td>Read register 'f'</td><td>Process Data</td><td>Write to destination</td></tr><tr><td>No Operation</td><td>No Operation</td><td>No Operation</td><td>No Operation</td></tr></tbody></table>	Q1	Q2	Q3	Q4	Decode	Read register 'f'	Process Data	Write to destination	No Operation	No Operation	No Operation	No Operation
Q1	Q2	Q3	Q4										
Decode	Read register 'f'	Process Data	Write to destination										
No Operation	No Operation	No Operation	No Operation										

Example: SUBULNK 23h

Before Instruction
FSR2 = 03FFh
PC = 0100h

After Instruction
FSR2 = 03DCh
PC = (TOS)

PIC18F85J90 FAMILY

23.2.3 BYTE-ORIENTED AND BIT-ORIENTED INSTRUCTIONS IN INDEXED LITERAL OFFSET MODE

Note: Enabling the PIC18 instruction set extension may cause legacy applications to behave erratically or fail entirely.

In addition to eight new commands in the extended set, enabling the extended instruction set also enables Indexed Literal Offset Addressing (**Section 5.6.1 “Indexed Addressing with Literal Offset”**). This has a significant impact on the way that many commands of the standard PIC18 instruction set are interpreted.

When the extended set is disabled, addresses embedded in opcodes are treated as literal memory locations: either as a location in the Access Bank ($a = 0$) or in a GPR bank designated by the BSR ($a = 1$). When the extended instruction set is enabled and $a = 0$, however, a file register argument of 5Fh or less is interpreted as an offset from the pointer value in FSR2 and not as a literal address. For practical purposes, this means that all instructions that use the Access RAM bit as an argument – that is, all byte-oriented and bit-oriented instructions, or almost half of the core PIC18 instructions – may behave differently when the extended instruction set is enabled.

When the content of FSR2 is 00h, the boundaries of the Access RAM are essentially remapped to their original values. This may be useful in creating backward-compatible code. If this technique is used, it may be necessary to save the value of FSR2 and restore it when moving back and forth between C and assembly routines in order to preserve the Stack Pointer. Users must also keep in mind the syntax requirements of the extended instruction set (see **Section 23.2.3.1 “Extended Instruction Syntax with Standard PIC18 Commands”**).

Although the Indexed Literal Offset mode can be very useful for dynamic stack and pointer manipulation, it can also be very annoying if a simple arithmetic operation is carried out on the wrong register. Users who are accustomed to the PIC18 programming must keep in mind that, when the extended instruction set is enabled, register addresses of 5Fh or less are used for Indexed Literal Offset Addressing.

Representative examples of typical byte-oriented and bit-oriented instructions in the Indexed Literal Offset mode are provided on the following page to show how execution is affected. The operand conditions shown in the examples are applicable to all instructions of these types.

23.2.3.1 Extended Instruction Syntax with Standard PIC18 Commands

When the extended instruction set is enabled, the file register argument ‘f’ in the standard byte-oriented and bit-oriented commands is replaced with the literal offset value ‘k’. As already noted, this occurs only when ‘f’ is less than or equal to 5Fh. When an offset value is used, it must be indicated by square brackets (“[]”). As with the extended instructions, the use of brackets indicates to the compiler that the value is to be interpreted as an index or an offset. Omitting the brackets, or using a value greater than 5Fh within the brackets, will generate an error in the MPASM Assembler.

If the index argument is properly bracketed for Indexed Literal Offset Addressing, the Access RAM argument is never specified; it will automatically be assumed to be ‘0’. This is in contrast to standard operation (extended instruction set disabled), when ‘a’ is set on the basis of the target address. Declaring the Access RAM bit in this mode will also generate an error in the MPASM Assembler.

The destination argument ‘d’ functions as before.

In the latest versions of the MPASM Assembler, language support for the extended instruction set must be explicitly invoked. This is done with either the command line option, `/y`, or the PE directive in the source listing.

23.2.4 CONSIDERATIONS WHEN ENABLING THE EXTENDED INSTRUCTION SET

It is important to note that the extensions to the instruction set may not be beneficial to all users. In particular, users who are not writing code that uses a software stack may not benefit from using the extensions to the instruction set.

Additionally, the Indexed Literal Offset Addressing mode may create issues with legacy applications written to the PIC18 assembler. This is because instructions in the legacy code may attempt to address registers in the Access Bank below 5Fh. Since these addresses are interpreted as literal offsets to FSR2 when the instruction set extension is enabled, the application may read or write to the wrong data addresses.

When porting an application to the PIC18F85J90 family, it is very important to consider the type of code. A large, re-entrant application that is written in C and would benefit from efficient compilation will do well when using the instruction set extensions. Legacy applications that heavily use the Access Bank will most likely not benefit from using the extended instruction set.

PIC18F85J90 FAMILY

ADDWF **ADD W to Indexed
(Indexed Literal Offset mode)**

Syntax: ADDWF [k] {,d}

Operands: $0 \leq k \leq 95$
 $d \in [0,1]$

Operation: $(W) + ((FSR2) + k) \rightarrow \text{dest}$

Status Affected: N, OV, C, DC, Z

Encoding:

0010	01d0	kkkk	kkkk
------	------	------	------

Description: The contents of W are added to the contents of the register indicated by FSR2, offset by the value 'k'.
 If 'd' is '0', the result is stored in W. If 'd' is '1', the result is stored back in register 'f' (default).

Words: 1

Cycles: 1

Q Cycle Activity:

Q1	Q2	Q3	Q4
Decode	Read 'k'	Process Data	Write to destination

Example: ADDWF [OFST] , 0

Before Instruction

W	=	17h
OFST	=	2Ch
FSR2	=	0A00h
Contents of 0A2Ch	=	20h

After Instruction

W	=	37h
Contents of 0A2Ch	=	20h

BSF **Bit Set Indexed
(Indexed Literal Offset mode)**

Syntax: BSF [k], b

Operands: $0 \leq f \leq 95$
 $0 \leq b \leq 7$

Operation: $1 \rightarrow ((FSR2) + k) < b >$

Status Affected: None

Encoding:

1000	bbb0	kkkk	kkkk
------	------	------	------

Description: Bit 'b' of the register indicated by FSR2, offset by the value 'k', is set.

Words: 1

Cycles: 1

Q Cycle Activity:

Q1	Q2	Q3	Q4
Decode	Read register 'f'	Process Data	Write to destination

Example: BSF [FLAG_OFST] , 7

Before Instruction

FLAG_OFST	=	0Ah
FSR2	=	0A00h
Contents of 0A0Ah	=	55h

After Instruction

Contents of 0A0Ah	=	D5h
-------------------	---	-----

SETF **Set Indexed
(Indexed Literal Offset mode)**

Syntax: SETF [k]

Operands: $0 \leq k \leq 95$

Operation: $FFh \rightarrow ((FSR2) + k)$

Status Affected: None

Encoding:

0110	1000	kkkk	kkkk
------	------	------	------

Description: The contents of the register indicated by FSR2, offset by 'k', are set to FFh.

Words: 1

Cycles: 1

Q Cycle Activity:

Q1	Q2	Q3	Q4
Decode	Read 'k'	Process Data	Write register

Example: SETF [OFST]

Before Instruction

OFST	=	2Ch
FSR2	=	0A00h
Contents of 0A2Ch	=	00h

After Instruction

Contents of 0A2Ch	=	FFh
-------------------	---	-----

PIC18F85J90 FAMILY

23.2.5 SPECIAL CONSIDERATIONS WITH MICROCHIP MPLAB® IDE TOOLS

The latest versions of Microchip's software tools have been designed to fully support the extended instruction set for the PIC18F85J90 family family. This includes the MPLAB C18 C Compiler, MPASM assembly language and MPLAB Integrated Development Environment (IDE).

When selecting a target device for software development, MPLAB IDE will automatically set default Configuration bits for that device. The default setting for the XINST Configuration bit is '0', disabling the extended instruction set and Indexed Literal Offset Addressing. For proper execution of applications developed to take advantage of the extended instruction set, XINST must be set during programming.

To develop software for the extended instruction set, the user must enable support for the instructions and the Indexed Addressing mode in their language tool(s). Depending on the environment being used, this may be done in several ways:

- A menu option or dialog box within the environment that allows the user to configure the language tool and its settings for the project
- A command line option
- A directive in the source code

These options vary between different compilers, assemblers and development environments. Users are encouraged to review the documentation accompanying their development systems for the appropriate information.

24.0 DEVELOPMENT SUPPORT

The PIC[®] microcontrollers are supported with a full range of hardware and software development tools:

- Integrated Development Environment
 - MPLAB[®] IDE Software
- Assemblers/Compilers/Linkers
 - MPASM[™] Assembler
 - MPLAB C18 and MPLAB C30 C Compilers
 - MPLINK[™] Object Linker/
MPLIB[™] Object Librarian
 - MPLAB ASM30 Assembler/Linker/Library
- Simulators
 - MPLAB SIM Software Simulator
- Emulators
 - MPLAB ICE 2000 In-Circuit Emulator
 - MPLAB REAL ICE[™] In-Circuit Emulator
- In-Circuit Debugger
 - MPLAB ICD 2
- Device Programmers
 - PICSTART[®] Plus Development Programmer
 - MPLAB PM3 Device Programmer
 - PICKit[™] 2 Development Programmer
- Low-Cost Demonstration and Development Boards and Evaluation Kits

24.1 MPLAB Integrated Development Environment Software

The MPLAB IDE software brings an ease of software development previously unseen in the 8/16-bit microcontroller market. The MPLAB IDE is a Windows[®] operating system-based application that contains:

- A single graphical interface to all debugging tools
 - Simulator
 - Programmer (sold separately)
 - Emulator (sold separately)
 - In-Circuit Debugger (sold separately)
- A full-featured editor with color-coded context
- A multiple project manager
- Customizable data windows with direct edit of contents
- High-level source code debugging
- Visual device initializer for easy register initialization
- Mouse over variable inspection
- Drag and drop variables from source to watch windows
- Extensive on-line help
- Integration of select third party tools, such as HI-TECH Software C Compilers and IAR C Compilers

The MPLAB IDE allows you to:

- Edit your source files (either assembly or C)
- One touch assemble (or compile) and download to PIC MCU emulator and simulator tools (automatically updates all project information)
- Debug using:
 - Source files (assembly or C)
 - Mixed assembly and C
 - Machine code

MPLAB IDE supports multiple debugging tools in a single development paradigm, from the cost-effective simulators, through low-cost in-circuit debuggers, to full-featured emulators. This eliminates the learning curve when upgrading to tools with increased flexibility and power.

PIC18F85J90 FAMILY

24.2 MPASM Assembler

The MPASM Assembler is a full-featured, universal macro assembler for all PIC MCUs.

The MPASM Assembler generates relocatable object files for the MPLINK Object Linker, Intel® standard HEX files, MAP files to detail memory usage and symbol reference, absolute LST files that contain source lines and generated machine code and COFF files for debugging.

The MPASM Assembler features include:

- Integration into MPLAB IDE projects
- User-defined macros to streamline assembly code
- Conditional assembly for multi-purpose source files
- Directives that allow complete control over the assembly process

24.3 MPLAB C18 and MPLAB C30 C Compilers

The MPLAB C18 and MPLAB C30 Code Development Systems are complete ANSI C compilers for Microchip's PIC18 and PIC24 families of microcontrollers and the dsPIC30 and dsPIC33 family of digital signal controllers. These compilers provide powerful integration capabilities, superior code optimization and ease of use not found with other compilers.

For easy source level debugging, the compilers provide symbol information that is optimized to the MPLAB IDE debugger.

24.4 MPLINK Object Linker/ MPLIB Object Librarian

The MPLINK Object Linker combines relocatable objects created by the MPASM Assembler and the MPLAB C18 C Compiler. It can link relocatable objects from precompiled libraries, using directives from a linker script.

The MPLIB Object Librarian manages the creation and modification of library files of precompiled code. When a routine from a library is called from a source file, only the modules that contain that routine will be linked in with the application. This allows large libraries to be used efficiently in many different applications.

The object linker/librarian features include:

- Efficient linking of single libraries instead of many smaller files
- Enhanced code maintainability by grouping related modules together
- Flexible creation of libraries with easy module listing, replacement, deletion and extraction

24.5 MPLAB ASM30 Assembler, Linker and Librarian

MPLAB ASM30 Assembler produces relocatable machine code from symbolic assembly language for dsPIC30F devices. MPLAB C30 C Compiler uses the assembler to produce its object file. The assembler generates relocatable object files that can then be archived or linked with other relocatable object files and archives to create an executable file. Notable features of the assembler include:

- Support for the entire dsPIC30F instruction set
- Support for fixed-point and floating-point data
- Command line interface
- Rich directive set
- Flexible macro language
- MPLAB IDE compatibility

24.6 MPLAB SIM Software Simulator

The MPLAB SIM Software Simulator allows code development in a PC-hosted environment by simulating the PIC MCUs and dsPIC® DSCs on an instruction level. On any given instruction, the data areas can be examined or modified and stimuli can be applied from a comprehensive stimulus controller. Registers can be logged to files for further run-time analysis. The trace buffer and logic analyzer display extend the power of the simulator to record and track program execution, actions on I/O, most peripherals and internal registers.

The MPLAB SIM Software Simulator fully supports symbolic debugging using the MPLAB C18 and MPLAB C30 C Compilers, and the MPASM and MPLAB ASM30 Assemblers. The software simulator offers the flexibility to develop and debug code outside of the hardware laboratory environment, making it an excellent, economical software development tool.

24.7 MPLAB ICE 2000 High-Performance In-Circuit Emulator

The MPLAB ICE 2000 In-Circuit Emulator is intended to provide the product development engineer with a complete microcontroller design tool set for PIC microcontrollers. Software control of the MPLAB ICE 2000 In-Circuit Emulator is advanced by the MPLAB Integrated Development Environment, which allows editing, building, downloading and source debugging from a single environment.

The MPLAB ICE 2000 is a full-featured emulator system with enhanced trace, trigger and data monitoring features. Interchangeable processor modules allow the system to be easily reconfigured for emulation of different processors. The architecture of the MPLAB ICE 2000 In-Circuit Emulator allows expansion to support new PIC microcontrollers.

The MPLAB ICE 2000 In-Circuit Emulator system has been designed as a real-time emulation system with advanced features that are typically found on more expensive development tools. The PC platform and Microsoft® Windows® 32-bit operating system were chosen to best make these features available in a simple, unified application.

24.8 MPLAB REAL ICE In-Circuit Emulator System

MPLAB REAL ICE In-Circuit Emulator System is Microchip's next generation high-speed emulator for Microchip Flash DSC® and MCU devices. It debugs and programs PIC® and dsPIC® Flash microcontrollers with the easy-to-use, powerful graphical user interface of the MPLAB Integrated Development Environment (IDE), included with each kit.

The MPLAB REAL ICE probe is connected to the design engineer's PC using a high-speed USB 2.0 interface and is connected to the target with either a connector compatible with the popular MPLAB ICD 2 system (RJ11) or with the new high speed, noise tolerant, low-voltage differential signal (LVDS) interconnection (CAT5).

MPLAB REAL ICE is field upgradeable through future firmware downloads in MPLAB IDE. In upcoming releases of MPLAB IDE, new devices will be supported, and new features will be added, such as software breakpoints and assembly code trace. MPLAB REAL ICE offers significant advantages over competitive emulators including low-cost, full-speed emulation, real-time variable watches, trace analysis, complex breakpoints, a ruggedized probe interface and long (up to three meters) interconnection cables.

24.9 MPLAB ICD 2 In-Circuit Debugger

Microchip's In-Circuit Debugger, MPLAB ICD 2, is a powerful, low-cost, run-time development tool, connecting to the host PC via an RS-232 or high-speed USB interface. This tool is based on the Flash PIC MCUs and can be used to develop for these and other PIC MCUs and dsPIC DSCs. The MPLAB ICD 2 utilizes the in-circuit debugging capability built into the Flash devices. This feature, along with Microchip's In-Circuit Serial Programming™ (ICSP™) protocol, offers cost-effective, in-circuit Flash debugging from the graphical user interface of the MPLAB Integrated Development Environment. This enables a designer to develop and debug source code by setting breakpoints, single stepping and watching variables, and CPU status and peripheral registers. Running at full speed enables testing hardware and applications in real time. MPLAB ICD 2 also serves as a development programmer for selected PIC devices.

24.10 MPLAB PM3 Device Programmer

The MPLAB PM3 Device Programmer is a universal, CE compliant device programmer with programmable voltage verification at VDDMIN and VDDMAX for maximum reliability. It features a large LCD display (128 x 64) for menus and error messages and a modular, detachable socket assembly to support various package types. The ICSP™ cable assembly is included as a standard item. In Stand-Alone mode, the MPLAB PM3 Device Programmer can read, verify and program PIC devices without a PC connection. It can also set code protection in this mode. The MPLAB PM3 connects to the host PC via an RS-232 or USB cable. The MPLAB PM3 has high-speed communications and optimized algorithms for quick programming of large memory devices and incorporates an SD/MMC card for file storage and secure data applications.

PIC18F85J90 FAMILY

24.11 PICSTART Plus Development Programmer

The PICSTART Plus Development Programmer is an easy-to-use, low-cost, prototype programmer. It connects to the PC via a COM (RS-232) port. MPLAB Integrated Development Environment software makes using the programmer simple and efficient. The PICSTART Plus Development Programmer supports most PIC devices in DIP packages up to 40 pins. Larger pin count devices, such as the PIC16C92X and PIC17C76X, may be supported with an adapter socket. The PICSTART Plus Development Programmer is CE compliant.

24.12 PICkit 2 Development Programmer

The PICkit™ 2 Development Programmer is a low-cost programmer and selected Flash device debugger with an easy-to-use interface for programming many of Microchip's baseline, mid-range and PIC18F families of Flash memory microcontrollers. The PICkit 2 Starter Kit includes a prototyping development board, twelve sequential lessons, software and HI-TECH's PICC™ Lite C compiler, and is designed to help get up to speed quickly using PIC® microcontrollers. The kit provides everything needed to program, evaluate and develop applications using Microchip's powerful, mid-range Flash memory family of microcontrollers.

24.13 Demonstration, Development and Evaluation Boards

A wide variety of demonstration, development and evaluation boards for various PIC MCUs and dsPIC DSCs allows quick application development on fully functional systems. Most boards include prototyping areas for adding custom circuitry and provide application firmware and source code for examination and modification.

The boards support a variety of features, including LEDs, temperature sensors, switches, speakers, RS-232 interfaces, LCD displays, potentiometers and additional EEPROM memory.

The demonstration and development boards can be used in teaching environments, for prototyping custom circuits and for learning about various microcontroller applications.

In addition to the PICDEM™ and dsPICDEM™ demonstration/development board series of circuits, Microchip has a line of evaluation kits and demonstration software for analog filter design, KEELOQ® security ICs, CAN, IrDA®, PowerSmart® battery management, SEEVAL® evaluation system, Sigma-Delta ADC, flow rate sensing, plus many more.

Check the Microchip web page (www.microchip.com) and the latest *"Product Selector Guide"* (DS00148) for the complete list of demonstration, development and evaluation kits.

25.0 ELECTRICAL CHARACTERISTICS

Absolute Maximum Ratings^(†)

Ambient temperature under bias	-40°C to +100°C
Storage temperature	-65°C to +150°C
Voltage on any digital only I/O pin or $\overline{\text{MCLR}}$ with respect to VSS (except VDD)	-0.3V to 6.0V
Voltage on any combined digital and analog pin with respect to VSS (except VDD and $\overline{\text{MCLR}}$).....	-0.3V to (VDD + 0.3V)
Voltage on VDDCORE with respect to VSS	-0.3V to 2.75V
Voltage on VDD with respect to VSS	-0.3V to 3.6V
Total power dissipation (Note 1)	1.0W
Maximum current out of VSS pin	300 mA
Maximum current into VDD pin	250 mA
Maximum output current sunk by PORTA<7:6> and any PORTB and PORTC I/O pins.....	25 mA
Maximum output current sunk by any PORTD, PORTE and PORTJ I/O pins	8 mA
Maximum output current sunk by PORTA<5:0> and any PORTF, PORTG and PORTH I/O pins	2 mA
Maximum output current sourced by PORTA<7:6> and any PORTB and PORTC I/O pins	25 mA
Maximum output current sourced by any PORTD, PORTE and PORTJ I/O pins	8 mA
Maximum output current sourced by PORTA<5:0> and any PORTF, PORTG and PORTH I/O pins	2 mA
Maximum current sunk by all ports combined	200 mA

Note 1: Power dissipation is calculated as follows:

$$P_{dis} = V_{DD} \times \{I_{DD} - \sum I_{OH}\} + \sum \{(V_{DD} - V_{OH}) \times I_{OH}\} + \sum (V_{OL} \times I_{OL})$$

† **NOTICE:** Stresses above those listed under “Absolute Maximum Ratings” may cause permanent damage to the device. This is a stress rating only and functional operation of the device at those or any other conditions above those indicated in the operation listings of this specification is not implied. Exposure to maximum rating conditions for extended periods may affect device reliability.

PIC18F85J90 FAMILY

FIGURE 25-1: PIC18F85J90 FAMILY VOLTAGE-FREQUENCY GRAPH, REGULATOR ENABLED (INDUSTRIAL)⁽¹⁾

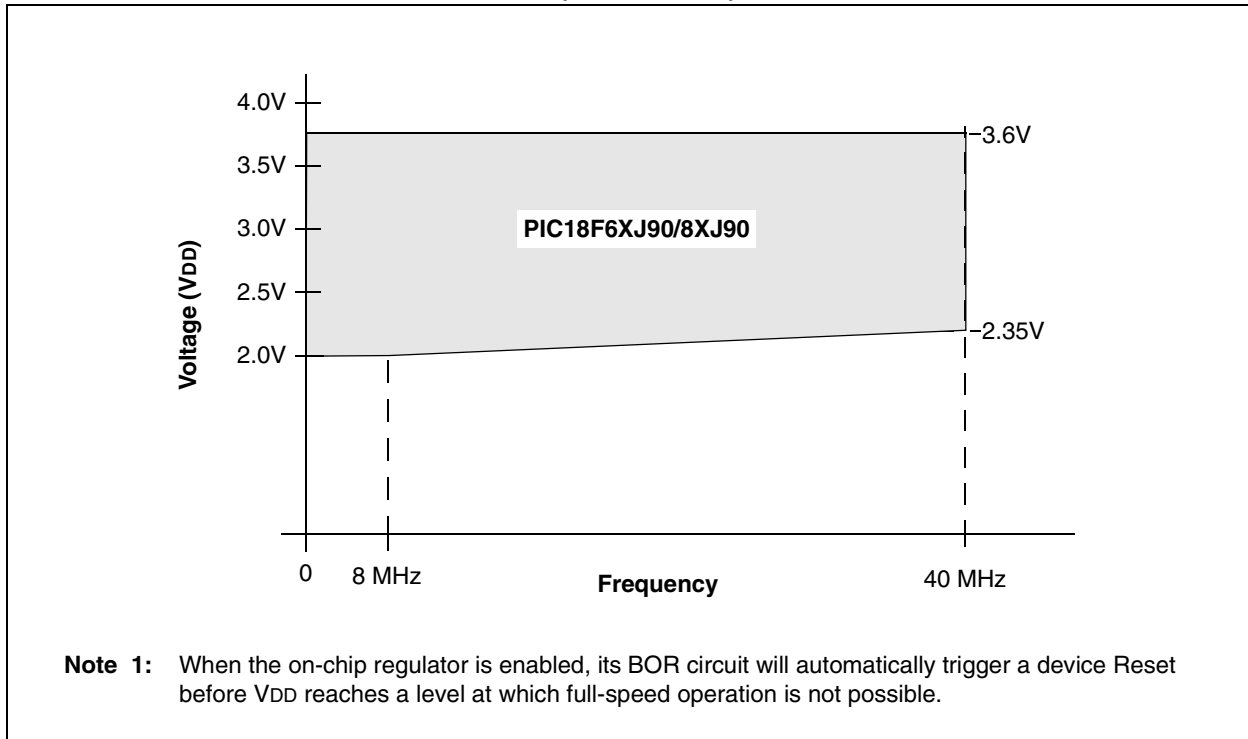
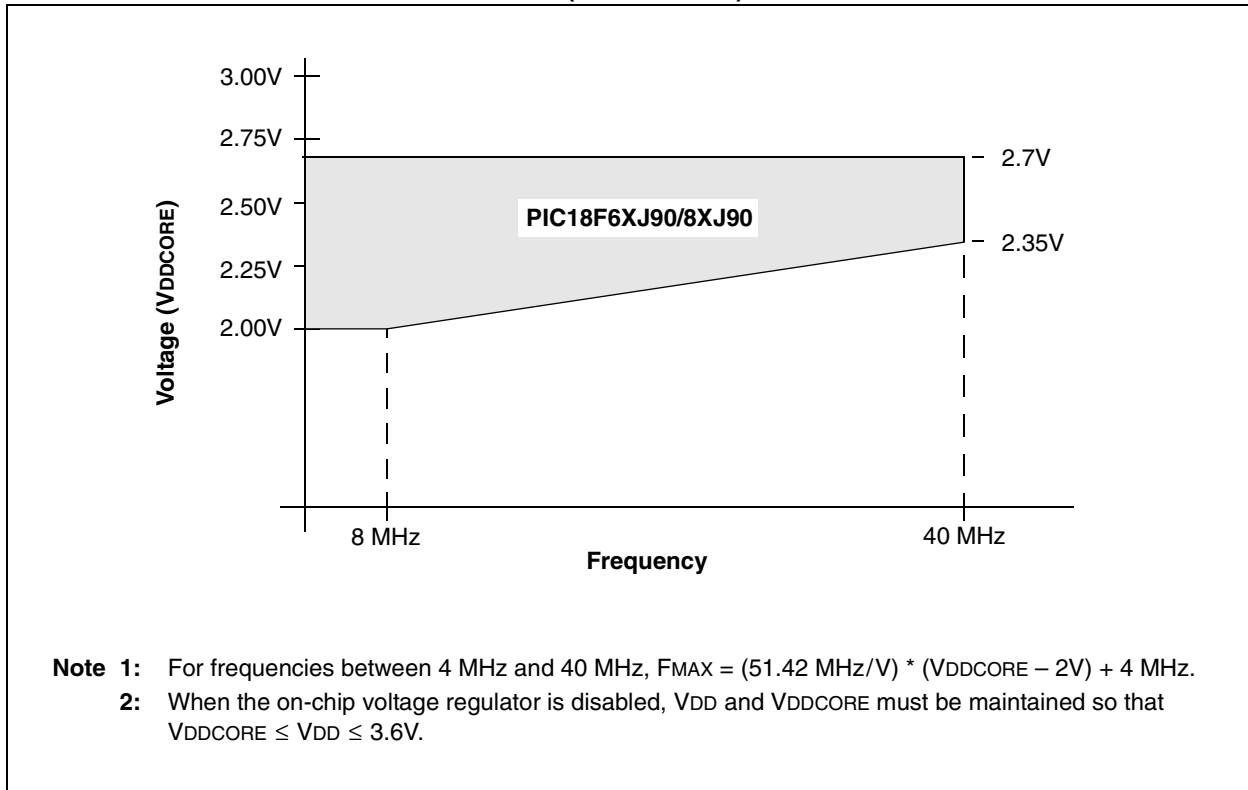

FIGURE 25-2: PIC18F85J90 FAMILY VOLTAGE-FREQUENCY GRAPH, REGULATOR DISABLED (INDUSTRIAL)^(1,2)



PIC18F85J90 FAMILY

25.1 DC Characteristics: Supply Voltage PIC18F85J90 Family (Industrial)

PIC18F85J90 Family (Industrial)			Standard Operating Conditions (unless otherwise stated) Operating temperature $-40^{\circ}\text{C} \leq T_A \leq +85^{\circ}\text{C}$ for industrial				
Param No.	Symbol	Characteristic	Min	Typ	Max	Units	Conditions
D001	VDD	Supply Voltage	VDDCORE 2.0	— —	3.6 3.6	V V	ENVREG tied to VSS ENVREG tied to VDD
D001B	VDDCORE	External Supply for Microcontroller Core	2.0	—	2.70	V	ENVREG tied to VSS
D001C	AVDD	Analog Supply Voltage	VDD - 0.3	—	VDD + 0.3	V	
D001D	AVSS	Analog Ground Potential	VSS - 0.3	—	VSS + 0.3	V	
D002	VDR	RAM Data Retention Voltage⁽¹⁾	1.5	—	—	V	
D003	VPOR	VDD Start Voltage to ensure internal Power-on Reset signal	—	—	0.7	V	See Section 4.3 “Power-on Reset (POR)” for details
D004	SVDD	VDD Rise Rate to ensure internal Power-on Reset signal	0.05	—	—	V/ms	See Section 4.3 “Power-on Reset (POR)” for details
D005	VBOR	Brown-out Reset Voltage	—	1.8	—	V	

Note 1: This is the limit to which VDD can be lowered in Sleep mode, or during a device Reset, without losing RAM data.

PIC18F85J90 FAMILY

25.2 DC Characteristics: Power-Down and Supply Current PIC18F85J90 Family (Industrial)

PIC18F85J90 Family (Industrial)		Standard Operating Conditions (unless otherwise stated)			
		Operating temperature $-40^{\circ}\text{C} \leq T_A \leq +85^{\circ}\text{C}$ for industrial			
Param No.	Device	Typ	Max	Units	Conditions
Power-Down Current (I_{PD})⁽¹⁾					
	All devices	0.2	0.9	μA	-40°C
		0.1	0.9	μA	$+25^{\circ}\text{C}$
		2.4	5	μA	$+85^{\circ}\text{C}$
	All devices	0.5	0.9	μA	-40°C
		0.1	0.9	μA	$+25^{\circ}\text{C}$
		2.7	5	μA	$+85^{\circ}\text{C}$
	All devices	2.7	6	μA	-40°C
		3.5	6	μA	$+25^{\circ}\text{C}$
		6.7	12	μA	$+85^{\circ}\text{C}$

- Note 1:** The power-down current in Sleep mode does not depend on the oscillator type. Power-down current is measured with the part in Sleep mode, with all I/O pins in high-impedance state and tied to VDD or VSS, and all features that add delta current disabled (such as WDT, Timer1 oscillator, BOR, etc.).
- 2:** The supply current is mainly a function of operating voltage, frequency and mode. Other factors, such as I/O pin loading and switching rate, oscillator type and circuit, internal code execution pattern and temperature, also have an impact on the current consumption.
The test conditions for all IDD measurements in active operation mode are:
 $\overline{\text{OSC1}}$ = external square wave, from rail-to-rail; all I/O pins tri-stated, pulled to VDD;
 $\overline{\text{MCLR}} = \text{VDD}$; WDT enabled/disabled as specified.
- 3:** Standard, low-cost 32 kHz crystals have an operating temperature range of -10°C to $+70^{\circ}\text{C}$. Extended temperature crystals are available at a much higher cost.
- 4:** Voltage regulator disabled (ENVREG tied to VSS).
- 5:** Voltage regulator enabled (ENVREG tied to VDD).
- 6:** Resistor ladder current is not included.
- 7:** Connecting an actual display will increase the current consumption depending on the size of the LCD.

PIC18F85J90 FAMILY

25.2 DC Characteristics: Power-Down and Supply Current PIC18F85J90 Family (Industrial) (Continued)

PIC18F85J90 Family (Industrial)		Standard Operating Conditions (unless otherwise stated) Operating temperature $-40^{\circ}\text{C} \leq T_A \leq +85^{\circ}\text{C}$ for industrial					
Param No.	Device	Typ	Max	Units	Conditions		
Supply Current (IDD)⁽²⁾							
	All devices	6.5	16	μA	-40°C	$V_{\text{DD}} = 2.0\text{V}$, $V_{\text{DDCORE}} = 2.0\text{V}^{(4)}$	FOSC = 31 kHz (INTRC_RUN mode, internal oscillator source)
		7	16	μA	$+25^{\circ}\text{C}$		
		9.5	20	μA	$+85^{\circ}\text{C}$		
	All devices	10	18	μA	-40°C	$V_{\text{DD}} = 2.5\text{V}$, $V_{\text{DDCORE}} = 2.5\text{V}^{(4)}$	
		10.5	18	μA	$+25^{\circ}\text{C}$		
		12.5	24	μA	$+85^{\circ}\text{C}$		
	All devices	41	100	μA	-40°C	$V_{\text{DD}} = 3.3\text{V}^{(5)}$	
		52	100	μA	$+25^{\circ}\text{C}$		
		71	110	μA	$+85^{\circ}\text{C}$		
	All devices	359	750	μA	-40°C	$V_{\text{DD}} = 2.0\text{V}$, $V_{\text{DDCORE}} = 2.0\text{V}^{(4)}$	FOSC = 1 MHz (INTOSC_RUN mode, internal oscillator source)
		387	750	μA	$+25^{\circ}\text{C}$		
		407	840	μA	$+85^{\circ}\text{C}$		
	All devices	438	850	μA	-40°C	$V_{\text{DD}} = 2.5\text{V}$, $V_{\text{DDCORE}} = 2.5\text{V}^{(4)}$	
		470	850	μA	$+25^{\circ}\text{C}$		
		491	910	μA	$+85^{\circ}\text{C}$		
	All devices	486	900	μA	-40°C	$V_{\text{DD}} = 3.3\text{V}^{(5)}$	
		526	900	μA	$+25^{\circ}\text{C}$		
		564	990	μA	$+85^{\circ}\text{C}$		
	All devices	0.76	1.45	mA	-40°C	$V_{\text{DD}} = 2.0\text{V}$, $V_{\text{DDCORE}} = 2.0\text{V}^{(4)}$	FOSC = 4 MHz (INTOSC_RUN mode, internal oscillator source)
		0.84	1.45	mA	$+25^{\circ}\text{C}$		
		0.9	1.6	mA	$+85^{\circ}\text{C}$		
	All devices	1.1	1.63	mA	-40°C	$V_{\text{DD}} = 2.5\text{V}$, $V_{\text{DDCORE}} = 2.5\text{V}^{(4)}$	
		1.18	1.63	mA	$+25^{\circ}\text{C}$		
		1.24	1.75	mA	$+85^{\circ}\text{C}$		
	All devices	1.25	1.86	mA	-40°C	$V_{\text{DD}} = 3.3\text{V}^{(5)}$	
		1.29	1.86	mA	$+25^{\circ}\text{C}$		
		1.37	1.94	mA	$+85^{\circ}\text{C}$		

- Note 1:** The power-down current in Sleep mode does not depend on the oscillator type. Power-down current is measured with the part in Sleep mode, with all I/O pins in high-impedance state and tied to VDD or VSS, and all features that add delta current disabled (such as WDT, Timer1 oscillator, BOR, etc.).
- 2:** The supply current is mainly a function of operating voltage, frequency and mode. Other factors, such as I/O pin loading and switching rate, oscillator type and circuit, internal code execution pattern and temperature, also have an impact on the current consumption.
The test conditions for all IDD measurements in active operation mode are:
 $\text{OSC1} = \text{external square wave, from rail-to-rail; all I/O pins tri-stated, pulled to VDD;}$
 $\text{MCLR} = \text{VDD; WDT enabled/disabled as specified.}$
- 3:** Standard, low-cost 32 kHz crystals have an operating temperature range of -10°C to $+70^{\circ}\text{C}$. Extended temperature crystals are available at a much higher cost.
- 4:** Voltage regulator disabled (ENVREG tied to VSS).
- 5:** Voltage regulator enabled (ENVREG tied to VDD).
- 6:** Resistor ladder current is not included.
- 7:** Connecting an actual display will increase the current consumption depending on the size of the LCD.

PIC18F85J90 FAMILY

25.2 DC Characteristics: Power-Down and Supply Current PIC18F85J90 Family (Industrial) (Continued)

PIC18F85J90 Family (Industrial)		Standard Operating Conditions (unless otherwise stated) Operating temperature $-40^{\circ}\text{C} \leq T_A \leq +85^{\circ}\text{C}$ for industrial					
Param No.	Device	Typ	Max	Units	Conditions		
Supply Current (IDD)⁽²⁾							
All devices		2.4	8	μA	-40°C	$V_{\text{DD}} = 2.0\text{V}$, $V_{\text{DDCORE}} = 2.0\text{V}^{(4)}$	FOSC = 31 kHz (INTOSC_IDLE mode, internal oscillator source)
		2.5	8	μA	$+25^{\circ}\text{C}$		
		4.8	12	μA	$+85^{\circ}\text{C}$		
All devices		3.2	9	μA	-40°C	$V_{\text{DD}} = 2.5\text{V}$, $V_{\text{DDCORE}} = 2.5\text{V}^{(4)}$	
		3.2	9	μA	$+25^{\circ}\text{C}$		
		6	14	μA	$+85^{\circ}\text{C}$		
All devices		62	82	μA	-40°C	$V_{\text{DD}} = 3.3\text{V}^{(5)}$	
		42	82	μA	$+25^{\circ}\text{C}$		
		59	97	μA	$+85^{\circ}\text{C}$		
All devices		251	570	μA	-40°C	$V_{\text{DD}} = 2.0\text{V}$, $V_{\text{DDCORE}} = 2.0\text{V}^{(4)}$	
		264	570	μA	$+25^{\circ}\text{C}$		
		272	590	μA	$+85^{\circ}\text{C}$		
All devices		284	610	μA	-40°C	$V_{\text{DD}} = 2.5\text{V}$, $V_{\text{DDCORE}} = 2.5\text{V}^{(4)}$	
		284	610	μA	$+25^{\circ}\text{C}$		
		293	650	μA	$+85^{\circ}\text{C}$		
All devices		295	710	μA	-40°C	$V_{\text{DD}} = 3.3\text{V}^{(5)}$	
		323	710	μA	$+25^{\circ}\text{C}$		
		392	790	μA	$+85^{\circ}\text{C}$		
All devices		368	760	μA	-40°C	$V_{\text{DD}} = 2.0\text{V}$, $V_{\text{DDCORE}} = 2.0\text{V}^{(4)}$	FOSC = 4 MHz (INTOSC_IDLE mode, internal oscillator source)
		362	760	μA	$+25^{\circ}\text{C}$		
		370	800	μA	$+85^{\circ}\text{C}$		
All devices		400	850	μA	-40°C	$V_{\text{DD}} = 2.5\text{V}$, $V_{\text{DDCORE}} = 2.5\text{V}^{(4)}$	
		410	850	μA	$+25^{\circ}\text{C}$		
		418	900	μA	$+85^{\circ}\text{C}$		
All devices		460	950	μA	-40°C	$V_{\text{DD}} = 3.3\text{V}^{(5)}$	
		462	950	μA	$+25^{\circ}\text{C}$		
		486	1000	μA	$+85^{\circ}\text{C}$		

- Note 1:** The power-down current in Sleep mode does not depend on the oscillator type. Power-down current is measured with the part in Sleep mode, with all I/O pins in high-impedance state and tied to VDD or VSS, and all features that add delta current disabled (such as WDT, Timer1 oscillator, BOR, etc.).
- Note 2:** The supply current is mainly a function of operating voltage, frequency and mode. Other factors, such as I/O pin loading and switching rate, oscillator type and circuit, internal code execution pattern and temperature, also have an impact on the current consumption.
The test conditions for all IDD measurements in active operation mode are:
OSC1 = external square wave, from rail-to-rail; all I/O pins tri-stated, pulled to VDD;
MCLR = VDD; WDT enabled/disabled as specified.
- Note 3:** Standard, low-cost 32 kHz crystals have an operating temperature range of -10°C to $+70^{\circ}\text{C}$. Extended temperature crystals are available at a much higher cost.
- Note 4:** Voltage regulator disabled (ENVREG tied to VSS).
- Note 5:** Voltage regulator enabled (ENVREG tied to VDD).
- Note 6:** Resistor ladder current is not included.
- Note 7:** Connecting an actual display will increase the current consumption depending on the size of the LCD.

PIC18F85J90 FAMILY

25.2 DC Characteristics: Power-Down and Supply Current PIC18F85J90 Family (Industrial) (Continued)

PIC18F85J90 Family (Industrial)		Standard Operating Conditions (unless otherwise stated) Operating temperature $-40^{\circ}\text{C} \leq T_A \leq +85^{\circ}\text{C}$ for industrial					
Param No.	Device	Typ	Max	Units	Conditions		
Supply Current (IDD)⁽²⁾							
	All devices	165	490	μA	-40°C	$V_{\text{DD}} = 2.0\text{V}$, $V_{\text{DDCORE}} = 2.0\text{V}^{(4)}$	FOSC = 1 MHz (PRI_RUN mode, EC oscillator)
		180	490	μA	$+25^{\circ}\text{C}$		
		200	490	μA	$+85^{\circ}\text{C}$		
	All devices	256	670	μA	-40°C	$V_{\text{DD}} = 2.5\text{V}$, $V_{\text{DDCORE}} = 2.5\text{V}^{(4)}$	
		260	670	μA	$+25^{\circ}\text{C}$		
		280	670	μA	$+85^{\circ}\text{C}$		
	All devices	460	850	μA	-40°C	$V_{\text{DD}} = 3.3\text{V}^{(5)}$	
		456	850	μA	$+25^{\circ}\text{C}$		
		482	850	μA	$+85^{\circ}\text{C}$		
	All devices	0.632	2.2	mA	-40°C	$V_{\text{DD}} = 2.0\text{V}$, $V_{\text{DDCORE}} = 2.0\text{V}^{(4)}$	
		0.681	2.2	mA	$+25^{\circ}\text{C}$		
		0.738	2.2	mA	$+85^{\circ}\text{C}$		
	All devices	0.912	2.5	mA	-40°C	$V_{\text{DD}} = 2.5\text{V}$, $V_{\text{DDCORE}} = 2.5\text{V}^{(4)}$	
		1.04	2.5	mA	$+25^{\circ}\text{C}$		
		1.04	2.5	mA	$+85^{\circ}\text{C}$		
	All devices	1.32	3.0	mA	-40°C	$V_{\text{DD}} = 3.3\text{V}^{(5)}$	
		1.32	3.0	mA	$+25^{\circ}\text{C}$		
		1.41	3.0	mA	$+85^{\circ}\text{C}$		
	All devices	7.47	14	mA	-40°C	$V_{\text{DD}} = 2.5\text{V}$, $V_{\text{DDCORE}} = 2.5\text{V}^{(4)}$	
		5.81	14	mA	$+25^{\circ}\text{C}$		
		6.32	13	mA	$+85^{\circ}\text{C}$		
	All devices	8.84	18	mA	-40°C	$V_{\text{DD}} = 3.3\text{V}^{(5)}$	
		8.66	18	mA	$+25^{\circ}\text{C}$		
		7.97	16	mA	$+85^{\circ}\text{C}$		

- Note 1:** The power-down current in Sleep mode does not depend on the oscillator type. Power-down current is measured with the part in Sleep mode, with all I/O pins in high-impedance state and tied to V_{DD} or V_{SS} , and all features that add delta current disabled (such as WDT, Timer1 oscillator, BOR, etc.).
- 2:** The supply current is mainly a function of operating voltage, frequency and mode. Other factors, such as I/O pin loading and switching rate, oscillator type and circuit, internal code execution pattern and temperature, also have an impact on the current consumption.
The test conditions for all I_{DD} measurements in active operation mode are:
OSC1 = external square wave, from rail-to-rail; all I/O pins tri-stated, pulled to V_{DD} ;
MCLR = V_{DD} ; WDT enabled/disabled as specified.
- 3:** Standard, low-cost 32 kHz crystals have an operating temperature range of -10°C to $+70^{\circ}\text{C}$. Extended temperature crystals are available at a much higher cost.
- 4:** Voltage regulator disabled (ENVREG tied to V_{SS}).
- 5:** Voltage regulator enabled (ENVREG tied to V_{DD}).
- 6:** Resistor ladder current is not included.
- 7:** Connecting an actual display will increase the current consumption depending on the size of the LCD.

PIC18F85J90 FAMILY

25.2 DC Characteristics: Power-Down and Supply Current PIC18F85J90 Family (Industrial) (Continued)

PIC18F85J90 Family (Industrial)		Standard Operating Conditions (unless otherwise stated) Operating temperature $-40^{\circ}\text{C} \leq T_A \leq +85^{\circ}\text{C}$ for industrial					
Param No.	Device	Typ	Max	Units	Conditions		
Supply Current (I_{DD})⁽²⁾							
	All devices	2.8	3.8	mA	-40°C	$V_{DD} = 2.0\text{V}$, $V_{DDCORE} = 2.0\text{V}^{(4)}$	FOSC = 4 MHz, 16 MHz internal (PRI_RUN mode, HSPLL oscillator)
		3.02	3.8	mA	$+25^{\circ}\text{C}$		
		3.01	4.5	mA	$+85^{\circ}\text{C}$		
	All devices	4.5	5.4	mA	-40°C	$V_{DD} = 2.5\text{V}$, $V_{DDCORE} = 2.5\text{V}^{(4)}$	FOSC = 4 MHz, 16 MHz internal (PRI_RUN mode, HSPLL oscillator)
		4.8	5.6	mA	$+25^{\circ}\text{C}$		
		4.54	5.6	mA	$+85^{\circ}\text{C}$		
	All devices	5.72	6.7	mA	-40°C	$V_{DD} = 3.3\text{V}^{(5)}$	FOSC = 4 MHz, 16 MHz internal (PRI_RUN mode, HSPLL oscillator)
		5.55	6.5	mA	$+25^{\circ}\text{C}$		
		5.3	6.5	mA	$+85^{\circ}\text{C}$		
	All devices	7.4	8.5	mA	-40°C	$V_{DD} = 2.5\text{V}$, $V_{DDCORE} = 2.5\text{V}^{(4)}$	FOSC = 10 MHz, 40 MHz internal (PRI_RUN mode, HSPLL oscillator)
		7.23	8.5	mA	$+25^{\circ}\text{C}$		
		6.55	7.5	mA	$+85^{\circ}\text{C}$		
	All devices	9.74	11.6	mA	-40°C	$V_{DD} = 3.3\text{V}^{(5)}$	FOSC = 10 MHz, 40 MHz internal (PRI_RUN mode, HSPLL oscillator)
		9.43	11.6	mA	$+25^{\circ}\text{C}$		
		8.89	10.5	mA	$+85^{\circ}\text{C}$		

- Note 1:** The power-down current in Sleep mode does not depend on the oscillator type. Power-down current is measured with the part in Sleep mode, with all I/O pins in high-impedance state and tied to V_{DD} or V_{SS} , and all features that add delta current disabled (such as WDT, Timer1 oscillator, BOR, etc.).
- 2:** The supply current is mainly a function of operating voltage, frequency and mode. Other factors, such as I/O pin loading and switching rate, oscillator type and circuit, internal code execution pattern and temperature, also have an impact on the current consumption.
The test conditions for all I_{DD} measurements in active operation mode are:
 $\text{OSC1} = \text{external square wave, from rail-to-rail; all I/O pins tri-stated, pulled to } V_{DD}$;
 $\text{MCLR} = V_{DD}$; WDT enabled/disabled as specified.
- 3:** Standard, low-cost 32 kHz crystals have an operating temperature range of -10°C to $+70^{\circ}\text{C}$. Extended temperature crystals are available at a much higher cost.
- 4:** Voltage regulator disabled (ENVREG tied to V_{SS}).
- 5:** Voltage regulator enabled (ENVREG tied to V_{DD}).
- 6:** Resistor ladder current is not included.
- 7:** Connecting an actual display will increase the current consumption depending on the size of the LCD.

PIC18F85J90 FAMILY

25.2 DC Characteristics: Power-Down and Supply Current PIC18F85J90 Family (Industrial) (Continued)

PIC18F85J90 Family (Industrial)		Standard Operating Conditions (unless otherwise stated) Operating temperature $-40^{\circ}\text{C} \leq T_A \leq +85^{\circ}\text{C}$ for industrial					
Param No.	Device	Typ	Max	Units	Conditions		
Supply Current (IDD)⁽²⁾							
All devices		50	120	μA	-40°C	$V_{\text{DD}} = 2.0\text{V}$, $V_{\text{DDCORE}} = 2.0\text{V}^{(4)}$	FOSC = 1 MHz (PRI_IDLE mode, EC oscillator)
		51	120	μA	$+25^{\circ}\text{C}$		
		54	130	μA	$+85^{\circ}\text{C}$		
All devices		223	480	μA	-40°C	$V_{\text{DD}} = 2.5\text{V}$, $V_{\text{DDCORE}} = 2.5\text{V}^{(4)}$	
		133	300	μA	$+25^{\circ}\text{C}$		
		110	270	μA	$+85^{\circ}\text{C}$		
All devices		307	550	μA	-40°C	$V_{\text{DD}} = 3.3\text{V}^{(5)}$	
		254	500	μA	$+25^{\circ}\text{C}$		
		194	460	μA	$+85^{\circ}\text{C}$		
All devices		307	850	μA	-40°C	$V_{\text{DD}} = 2.0\text{V}$, $V_{\text{DDCORE}} = 2.0\text{V}^{(4)}$	FOSC = 4 MHz (PRI_IDLE mode, EC oscillator)
		200	850	μA	$+25^{\circ}\text{C}$		
		202	800	μA	$+85^{\circ}\text{C}$		
All devices		483	950	μA	-40°C	$V_{\text{DD}} = 2.5\text{V}$, $V_{\text{DDCORE}} = 2.5\text{V}^{(4)}$	
		318	950	μA	$+25^{\circ}\text{C}$		
		343	900	μA	$+85^{\circ}\text{C}$		
All devices		524	1.3	mA	-40°C	$V_{\text{DD}} = 3.3\text{V}^{(5)}$	
		474	1.2	mA	$+25^{\circ}\text{C}$		
		468	1.2	mA	$+85^{\circ}\text{C}$		
All devices		2.38	8	mA	-40°C	$V_{\text{DD}} = 2.5\text{V}$, $V_{\text{DDCORE}} = 2.5\text{V}^{(4)}$	FOSC = 40 MHz (PRI_IDLE mode, EC oscillator)
		2.04	8	mA	$+25^{\circ}\text{C}$		
		2.52	9	mA	$+85^{\circ}\text{C}$		
All devices		3.02	10	mA	-40°C	$V_{\text{DD}} = 3.3\text{V}^{(5)}$	
		2.99	10	mA	$+25^{\circ}\text{C}$		
		4.23	11	mA	$+85^{\circ}\text{C}$		

- Note 1:** The power-down current in Sleep mode does not depend on the oscillator type. Power-down current is measured with the part in Sleep mode, with all I/O pins in high-impedance state and tied to V_{DD} or V_{SS} , and all features that add delta current disabled (such as WDT, Timer1 oscillator, BOR, etc.).
- 2:** The supply current is mainly a function of operating voltage, frequency and mode. Other factors, such as I/O pin loading and switching rate, oscillator type and circuit, internal code execution pattern and temperature, also have an impact on the current consumption.
The test conditions for all IDD measurements in active operation mode are:
OSC1 = external square wave, from rail-to-rail; all I/O pins tri-stated, pulled to V_{DD} ;
MCLR = V_{DD} ; WDT enabled/disabled as specified.
- 3:** Standard, low-cost 32 kHz crystals have an operating temperature range of -10°C to $+70^{\circ}\text{C}$. Extended temperature crystals are available at a much higher cost.
- 4:** Voltage regulator disabled (ENVREG tied to V_{SS}).
- 5:** Voltage regulator enabled (ENVREG tied to V_{DD}).
- 6:** Resistor ladder current is not included.
- 7:** Connecting an actual display will increase the current consumption depending on the size of the LCD.

PIC18F85J90 FAMILY

25.2 DC Characteristics: Power-Down and Supply Current PIC18F85J90 Family (Industrial) (Continued)

PIC18F85J90 Family (Industrial)		Standard Operating Conditions (unless otherwise stated) Operating temperature -40°C ≤ TA ≤ +85°C for industrial					
Param No.	Device	Typ	Max	Units	Conditions		
Supply Current (IDD)⁽²⁾							
	All devices	10.5	22	μA	-40°C	VDD = 2.0V, VDDCORE = 2.0V ⁽⁴⁾	FOSC = 32 kHz ⁽³⁾ (SEC_RUN mode, Timer1 as clock)
		13.4	28	μA	+25°C		
		17.6	40	μA	+85°C		
	All devices	13.2	30	μA	-40°C	VDD = 2.5V, VDDCORE = 2.5V ⁽⁴⁾	
		16.2	35	μA	+25°C		
		20.7	50	μA	+85°C		
	All devices	39	120	μA	-40°C	VDD = 3.3V ⁽⁵⁾	
		58	150	μA	+25°C		
		75	190	μA	+85°C		
	All devices	5.7	15	μA	-40°C	VDD = 2.0V, VDDCORE = 2.0V ⁽⁴⁾	FOSC = 32 kHz ⁽³⁾ (SEC_IDLE mode, Timer1 as clock)
		8.9	20	μA	+25°C		
		12.8	26	μA	+85°C		
	All devices	6.6	17	μA	-40°C	VDD = 2.5V, VDDCORE = 2.5V ⁽⁴⁾	
		9.7	24	μA	+25°C		
		13.7	30	μA	+85°C		
	All devices	39	115	μA	-40°C	VDD = 3.3V ⁽⁵⁾	
		52.8	145	μA	+25°C		
		72.7	185	μA	+85°C		

- Note 1:** The power-down current in Sleep mode does not depend on the oscillator type. Power-down current is measured with the part in Sleep mode, with all I/O pins in high-impedance state and tied to VDD or VSS, and all features that add delta current disabled (such as WDT, Timer1 oscillator, BOR, etc.).
- 2:** The supply current is mainly a function of operating voltage, frequency and mode. Other factors, such as I/O pin loading and switching rate, oscillator type and circuit, internal code execution pattern and temperature, also have an impact on the current consumption.
The test conditions for all IDD measurements in active operation mode are:
OSC1 = external square wave, from rail-to-rail; all I/O pins tri-stated, pulled to VDD;
MCLR = VDD; WDT enabled/disabled as specified.
- 3:** Standard, low-cost 32 kHz crystals have an operating temperature range of -10°C to +70°C. Extended temperature crystals are available at a much higher cost.
- 4:** Voltage regulator disabled (ENVREG tied to VSS).
- 5:** Voltage regulator enabled (ENVREG tied to VDD).
- 6:** Resistor ladder current is not included.
- 7:** Connecting an actual display will increase the current consumption depending on the size of the LCD.

PIC18F85J90 FAMILY

25.2 DC Characteristics: Power-Down and Supply Current PIC18F85J90 Family (Industrial) (Continued)

PIC18F85J90 Family (Industrial)		Standard Operating Conditions (unless otherwise stated) Operating temperature $-40^{\circ}\text{C} \leq T_A \leq +85^{\circ}\text{C}$ for industrial					
Param No.	Device	Typ	Max	Units	Conditions		
D022 (ΔI_{WDT})	Watchdog Timer	Module Differential Currents (ΔI_{WDT} , ΔI_{LCD} , ΔI_{OSCB} , ΔI_{AD})					
		1.6	4	μA	-40°C	$V_{DD} = 2.0\text{V}$, $V_{DDCORE} = 2.0\text{V}^{(4)}$	
		1.7	4	μA	$+25^{\circ}\text{C}$		
		1.6	4	μA	$+85^{\circ}\text{C}$		
		2.5	5	μA	-40°C	$V_{DD} = 2.5\text{V}$, $V_{DDCORE} = 2.5\text{V}^{(4)}$	
		2.5	5	μA	$+25^{\circ}\text{C}$		
		2.3	5	μA	$+85^{\circ}\text{C}$		
		3.8	6	μA	-40°C	$V_{DD} = 3.3\text{V}^{(5)}$	
		2.6	6	μA	$+25^{\circ}\text{C}$		
		2.4	6	μA	$+85^{\circ}\text{C}$		
D024 (ΔI_{LCD})	LCD Module	2 ^(6,7)	5	μA	$+25^{\circ}\text{C}$	$V_{DD} = 2.0\text{V}$	
		2.7 ^(6,7)	5	μA	$+25^{\circ}\text{C}$	$V_{DD} = 2.5\text{V}$	
		3.5 ^(6,7)	7	μA	$+25^{\circ}\text{C}$	$V_{DD} = 3.0\text{V}$	
		16 ⁽⁷⁾	25	μA	$+25^{\circ}\text{C}$	$V_{DD} = 2.0\text{V}$	Charge Pump BIAS<2:0> = 111; CPEN = 1; CKSEL<1:0> = 11;
		17 ⁽⁷⁾	25	μA	$+25^{\circ}\text{C}$	$V_{DD} = 2.5\text{V}$	
		24 ⁽⁷⁾	40	μA	$+25^{\circ}\text{C}$	$V_{DD} = 3.0\text{V}$	
D025 (ΔI_{OSCB})	Timer1 Oscillator	6.6	12.5	μA	-40°C	$V_{DD} = 2.0\text{V}$, $V_{DDCORE} = 2.0\text{V}^{(4)}$	32 kHz on Timer1 ⁽³⁾
		7.9	12.5	μA	$+25^{\circ}\text{C}$		
		11.5	18.5	μA	$+85^{\circ}\text{C}$		
		7.2	12.5	μA	-40°C	$V_{DD} = 2.5\text{V}$, $V_{DDCORE} = 2.5\text{V}^{(4)}$	
		8.1	12.5	μA	$+25^{\circ}\text{C}$		
		11.9	18.5	μA	$+85^{\circ}\text{C}$		
		7	12.5	μA	-40°C	$V_{DD} = 3.3\text{V}^{(5)}$	
		9	12.5	μA	$+25^{\circ}\text{C}$		
11	18.5	μA	$+85^{\circ}\text{C}$				
D026 (ΔI_{AD})	A/D Converter	1	1.5	μA	-40°C to $+85^{\circ}\text{C}$	$V_{DD} = 2.0\text{V}$, $V_{DDCORE} = 2.0\text{V}^{(4)}$	A/D on, not converting
		1	1.5	μA	-40°C to $+85^{\circ}\text{C}$	$V_{DD} = 2.5\text{V}$, $V_{DDCORE} = 2.5\text{V}^{(4)}$	
		1	1.5	μA	-40°C to $+85^{\circ}\text{C}$	$V_{DD} = 3.3\text{V}^{(5)}$	

- Note 1:** The power-down current in Sleep mode does not depend on the oscillator type. Power-down current is measured with the part in Sleep mode, with all I/O pins in high-impedance state and tied to V_{DD} or V_{SS} , and all features that add delta current disabled (such as WDT, Timer1 oscillator, BOR, etc.).
- 2:** The supply current is mainly a function of operating voltage, frequency and mode. Other factors, such as I/O pin loading and switching rate, oscillator type and circuit, internal code execution pattern and temperature, also have an impact on the current consumption.
The test conditions for all I_{DD} measurements in active operation mode are:
OSC1 = external square wave, from rail-to-rail; all I/O pins tri-stated, pulled to V_{DD} ;
MCLR = V_{DD} ; WDT enabled/disabled as specified.
- 3:** Standard, low-cost 32 kHz crystals have an operating temperature range of -10°C to $+70^{\circ}\text{C}$. Extended temperature crystals are available at a much higher cost.
- 4:** Voltage regulator disabled (ENVREG tied to V_{SS}).
- 5:** Voltage regulator enabled (ENVREG tied to V_{DD}).
- 6:** Resistor ladder current is not included.
- 7:** Connecting an actual display will increase the current consumption depending on the size of the LCD.

PIC18F85J90 FAMILY

25.3 DC Characteristics: PIC18F84J90 Family (Industrial)

DC CHARACTERISTICS			Standard Operating Conditions (unless otherwise stated) Operating temperature $-40^{\circ}\text{C} \leq T_A \leq +85^{\circ}\text{C}$ for industrial			
Param No.	Symbol	Characteristic	Min	Max	Units	Conditions
	V _{IL}	Input Low Voltage All I/O ports:				
D030		with TTL buffer	V _{SS}	0.15 V _{DD}	V	
D031		with Schmitt Trigger buffer	V _{SS}	0.2 V _{DD}	V	
D032	$\overline{\text{MCLR}}$		V _{SS}	0.2 V _{DD}	V	
D033	OSC1		V _{SS}	0.3 V _{DD}	V	HS, HSPLL modes
D033A	OSC1		V _{SS}	0.2 V _{DD}	V	EC, ECPLL modes
D034	T13CKI		V _{SS}	0.3	V	
	V _{IH}	Input High Voltage I/O ports with analog functions:				
D040		with TTL buffer	0.25 V _{DD} + 0.8V	V _{DD}	V	V _{DD} < 3.3V
D041		with Schmitt Trigger buffer	0.8 V _{DD}	V _{DD}	V	
		Digital-only I/O ports:				
		with TTL buffer	0.25 V _{DD} + 0.8V	5.5	V	V _{DD} < 3.3V
			2.0	5.5	V	3.3V ≤ V _{DD} ≤ 3.6V
		with Schmitt Trigger buffer	0.8 V _{DD}	5.5	V	
D042	$\overline{\text{MCLR}}$		0.8 V _{DD}	V _{DD}	V	
D043	OSC1		0.7 V _{DD}	V _{DD}	V	HS, HSPLL modes
D043A	OSC1		0.8 V _{DD}	V _{DD}	V	EC, ECPLL modes
D044	T13CKI		1.6	V _{DD}	V	
	I _{IL}	Input Leakage Current⁽¹⁾ I/O ports	—	±1	μA	V _{SS} ≤ V _{PIN} ≤ V _{DD} , Pin at high-impedance
D060			—	±1	μA	
D061	$\overline{\text{MCLR}}$		—	±1	μA	V _{SS} ≤ V _{PIN} ≤ V _{DD}
D063	OSC1		—	±5	μA	V _{SS} ≤ V _{PIN} ≤ V _{DD}
	I _{PU}	Weak Pull-up Current PORTB weak pull-up current	30	240	μA	V _{DD} = 3.3V, V _{PIN} = V _{SS}
D070	I _{PURB}					

Note 1: Negative current is defined as current sourced by the pin.

PIC18F85J90 FAMILY

25.3 DC Characteristics: PIC18F84J90 Family (Industrial) (Continued)

DC CHARACTERISTICS			Standard Operating Conditions (unless otherwise stated) Operating temperature $-40^{\circ}\text{C} \leq T_A \leq +85^{\circ}\text{C}$ for industrial			
Param No.	Symbol	Characteristic	Min	Max	Units	Conditions
D080	VOL	Output Low Voltage				
		I/O ports: PORTA, PORTF, PORTG, PORTH	—	0.4	V	$I_{OL} = 2 \text{ mA}$, $V_{DD} = 3.3\text{V}$, -40°C to $+85^{\circ}\text{C}$
		PORTD, PORTE, PORTJ	—	0.4	V	$I_{OL} = 3.4 \text{ mA}$, $V_{DD} = 3.3\text{V}$, -40°C to $+85^{\circ}\text{C}$
D083	VOL	PORTB, PORTC	—	0.4	V	$I_{OL} = 3.4 \text{ mA}$, $V_{DD} = 3.3\text{V}$, -40°C to $+85^{\circ}\text{C}$
		OSC2/CLKO (EC, ECPLL modes)	—	0.4	V	$I_{OL} = 1.6 \text{ mA}$, $V_{DD} = 3.3\text{V}$, -40°C to $+85^{\circ}\text{C}$
D090	VOH	Output High Voltage⁽¹⁾				
		I/O ports: PORTA, PORTF, PORTG, PORTH	2.4	—	V	$I_{OH} = -2 \text{ mA}$, $V_{DD} = 3.3\text{V}$, -40°C to $+85^{\circ}\text{C}$
		PORTD, PORTE, PORTJ	2.4	—	V	$I_{OH} = -2 \text{ mA}$, $V_{DD} = 3.3\text{V}$, -40°C to $+85^{\circ}\text{C}$
D092	VOH	PORTB, PORTC	2.4	—	V	$I_{OH} = -2 \text{ mA}$, $V_{DD} = 3.3\text{V}$, -40°C to $+85^{\circ}\text{C}$
		OSC2/CLKO (INTOSC, EC, ECPLL modes)	2.4	—	V	$I_{OH} = -1 \text{ mA}$, $V_{DD} = 3.3\text{V}$, -40°C to $+85^{\circ}\text{C}$
D100 ⁽⁴⁾	COSC2	Capacitive Loading Specs on Output Pins				
		OSC2 pin	—	15	pF	In HS mode when external clock is used to drive OSC1
		All I/O pins and OSC2	—	50	pF	To meet the AC Timing Specifications
D102	CB	SCLx, SDAx	—	400	pF	I ² C™ Specification

Note 1: Negative current is defined as current sourced by the pin.

PIC18F85J90 FAMILY

TABLE 25-1: MEMORY PROGRAMMING REQUIREMENTS

DC CHARACTERISTICS			Standard Operating Conditions (unless otherwise stated) Operating temperature $-40^{\circ}\text{C} \leq T_A \leq +85^{\circ}\text{C}$ for industrial				
Param No.	Sym	Characteristic	Min	Typ†	Max	Units	Conditions
Program Flash Memory							
D130	EP	Cell Endurance	1K	10K	—	E/W	-40°C to $+85^{\circ}\text{C}$
D131	VPR	VDD for Read	V _{MIN}	—	3.6	V	V _{MIN} = Minimum operating voltage
D132B	VPEW	VDD for Self-Timed Write	V _{MIN}	—	3.6	V	V _{MIN} = Minimum operating voltage
D133A	TIW	Self-Timed Write Cycle Time	—	2.8	—	ms	
D134	TRETD	Characteristic Retention	20	—	—	Year	Provided no other specifications are violated
D135	IDDP	Supply Current during Programming	—	3	7	mA	
D1xxx	TWE	Writes per Erase Cycle	—	—	1		Per one physical word address

† Data in “Typ” column is at 3.3V, 25°C unless otherwise stated. These parameters are for design guidance only and are not tested.

PIC18F85J90 FAMILY

TABLE 25-2: COMPARATOR SPECIFICATIONS

Operating Conditions: $3.0V \leq V_{DD} \leq 3.6V$, $-40^{\circ}C \leq T_A \leq +85^{\circ}C$ (unless otherwise stated)							
Param No.	Sym	Characteristics	Min	Typ	Max	Units	Comments
D300	V _{IOFF}	Input Offset Voltage	—	±5.0	±10	mV	
D301	V _{ICM}	Input Common Mode Voltage*	0	—	$AV_{DD} - 1.5$	V	
D302	CMRR	Common Mode Rejection Ratio*	55	—	—	dB	
300	T _{RESP}	Response Time ^{(1)*}	—	150	400	ns	
301	T _{MC2OV}	Comparator Mode Change to Output Valid*	—	—	10	μs	

* These parameters are characterized but not tested.

Note 1: Response time measured with one comparator input at $(AV_{DD} - 1.5)/2$, while the other input transitions from V_{SS} to V_{DD} .

TABLE 25-3: VOLTAGE REFERENCE SPECIFICATIONS

Operating Conditions: $3.0V \leq V_{DD} \leq 3.6V$, $-40^{\circ}C \leq T_A \leq +85^{\circ}C$ (unless otherwise stated)							
Param No.	Sym	Characteristics	Min	Typ	Max	Units	Comments
D310	V _{RES}	Resolution	$V_{DD}/24$	—	$V_{DD}/32$	LSb	
D311	V _{RAA}	Absolute Accuracy	—	—	1/2	LSb	
D312	V _{RUR}	Unit Resistor Value (R)	—	2k	—	Ω	
310	T _{SET}	Settling Time ⁽¹⁾	—	—	10	μs	

Note 1: Settling time measured while $CVRR = 1$ and $CVR3:CVR0$ transitions from '0000' to '1111'.

TABLE 25-4: INTERNAL VOLTAGE REGULATOR SPECIFICATIONS

Operating Conditions: $-40^{\circ}C \leq T_A \leq +85^{\circ}C$ (unless otherwise stated)							
Param No.	Sym	Characteristics	Min	Typ	Max	Units	Comments
	V _{RGOUT}	Regulator Output Voltage*	—	2.5	—	V	
	CEFC	External Filter Capacitor Value*	4.7	10	—	μF	Capacitor must be low ESR

* These parameters are characterized but not tested. Parameter numbers not yet assigned for these specifications.

PIC18F85J90 FAMILY

TABLE 25-5: INTERNAL LCD VOLTAGE REGULATOR SPECIFICATIONS

Operating Conditions: $2.0V \leq V_{DD} \leq 3.6V$, $-40^{\circ}C \leq T_A \leq +85^{\circ}C$ (unless otherwise stated)							
Param No.	Sym	Characteristics	Min	Typ	Max	Units	Comments
	C_{FLY}	Fly Back Capacitor	0.47	4.7		μF	Capacitor must be low ESR
	V_{BIAS}	V_{PK-PK} between LCDBIAS0 & LCDBIAS3		3.40	3.6	V	BIAS2:BIAS0 = 111
				3.27		V	BIAS2:BIAS0 = 110
				3.14		V	BIAS2:BIAS0 = 101
				3.01		V	BIAS2:BIAS0 = 100
				2.88		V	BIAS2:BIAS0 = 011
				2.75		V	BIAS2:BIAS0 = 010
				2.62		V	BIAS2:BIAS0 = 001
				2.49		V	BIAS2:BIAS0 = 000

PIC18F85J90 FAMILY

25.4 AC (Timing) Characteristics

25.4.1 TIMING PARAMETER SYMBOLOGY

The timing parameter symbols have been created following one of the following formats:

1. TppS2ppS
2. TppS
3. Tcc:ST (I²C specifications only)
4. Ts (I²C specifications only)

<p>T</p> <p>F Frequency</p>	<p>T Time</p>
----------------------------------	--------------------

Lowercase letters (pp) and their meanings:

<p>pp</p> <p>cc CCP1</p> <p>ck CLKO</p> <p>cs \overline{CS}</p> <p>di SDI</p> <p>do SDO</p> <p>dt Data in</p> <p>io I/O port</p> <p>mc MCLR</p>	<p>osc OSC1</p> <p>rd \overline{RD}</p> <p>rw \overline{RD} or \overline{WR}</p> <p>sc SCK</p> <p>ss \overline{SS}</p> <p>t0 T0CKI</p> <p>t1 T13CKI</p> <p>wr \overline{WR}</p>
------------------------------------------------------------------------------------------------------------------------------------------------------------------------------------------------------	------------------------------------------------------------------------------------------------------------------------------------------------------------------------------------------------------------------------------------------------------------------------------------------

Uppercase letters and their meanings:

<p>S</p> <p>F Fall</p> <p>H High</p> <p>I Invalid (High-impedance)</p> <p>L Low</p> <p>I²C only</p> <p>AA output access</p> <p>BUF Bus free</p>	<p>P Period</p> <p>R Rise</p> <p>V Valid</p> <p>Z High-impedance</p> <p>High High</p> <p>Low Low</p>
------------------------------------------------------------------------------------------------------------------------------------------------------------------------------------------	---------------------------------------------------------------------------------------------------------------------------------

Tcc:ST (I²C specifications only)

<p>CC</p> <p>HD Hold</p> <p>ST</p> <p>DAT DATA input hold</p> <p>STA Start condition</p>	<p>SU Setup</p> <p>STO Stop condition</p>
---------------------------------------------------------------------------------------------------------	-----------------------------------------------------

PIC18F85J90 FAMILY

25.4.2 TIMING CONDITIONS

The temperature and voltages specified in Table 25-6 apply to all timing specifications unless otherwise noted. Figure 25-3 specifies the load conditions for the timing specifications.

TABLE 25-6: TEMPERATURE AND VOLTAGE SPECIFICATIONS – AC

AC CHARACTERISTICS	Standard Operating Conditions (unless otherwise stated)
	Operating temperature $-40^{\circ}\text{C} \leq T_A \leq +85^{\circ}\text{C}$ for industrial
	Operating voltage V_{DD} range as described in Section 25.1 and Section 25.3 .

FIGURE 25-3: LOAD CONDITIONS FOR DEVICE TIMING SPECIFICATIONS

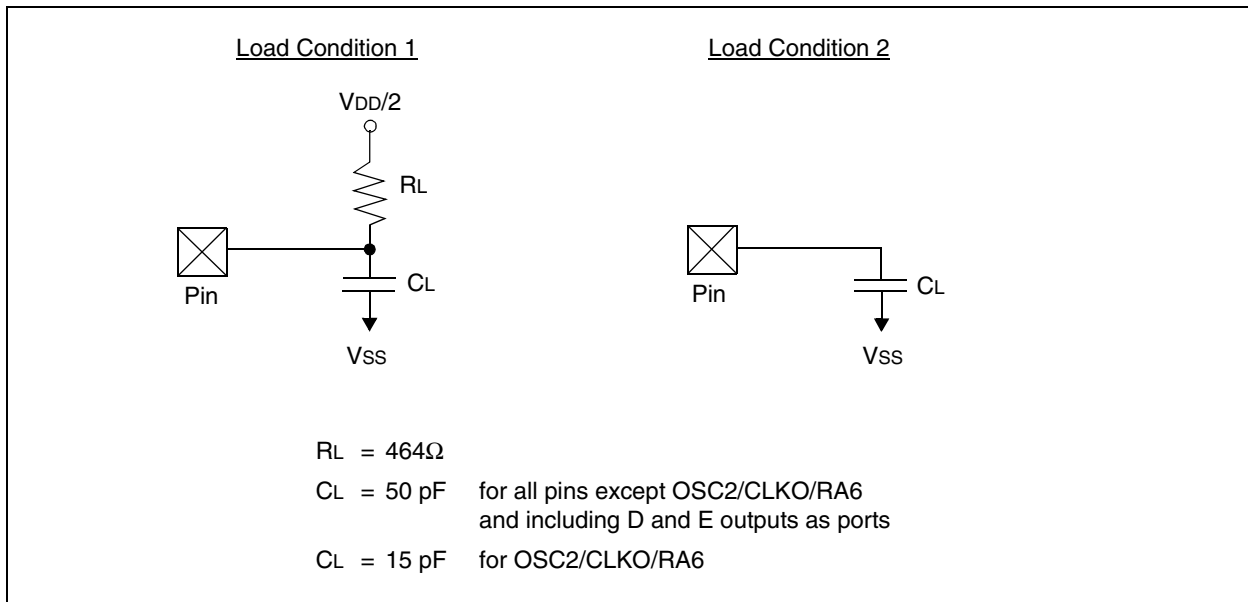

PIC18F85J90 FAMILY

25.4.3 TIMING DIAGRAMS AND SPECIFICATIONS

FIGURE 25-4: EXTERNAL CLOCK TIMING

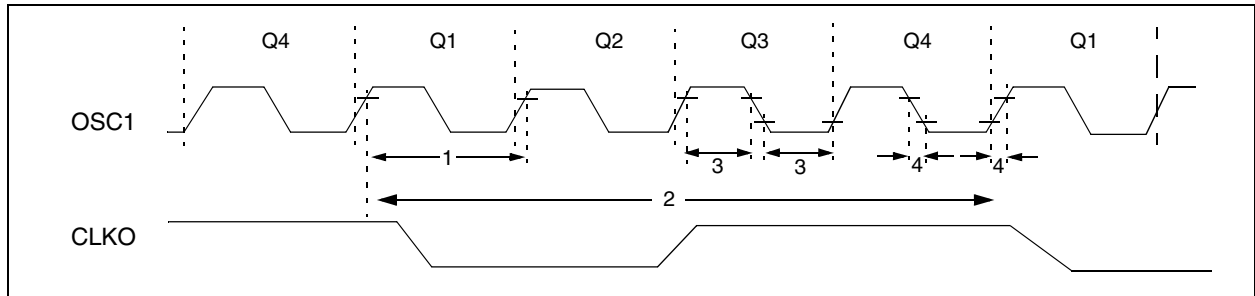

TABLE 25-7: EXTERNAL CLOCK TIMING REQUIREMENTS

Param. No.	Symbol	Characteristic	Min	Max	Units	Conditions
1A	FOSC	External CLKI Frequency ⁽¹⁾	DC	40	MHz	ECPLL Oscillator mode
		Oscillator Frequency ⁽¹⁾	DC	40	MHz	HSPLL Oscillator mode
1	TOSC	External CLKI Period ⁽¹⁾	25	—	ns	EC Oscillator mode
		Oscillator Period ⁽¹⁾	25	250	ns	HS Oscillator mode
2	Tcy	Instruction Cycle Time ⁽¹⁾	100	—	ns	Tcy = 4/Fosc, Industrial
3	TosL, TosH	External Clock in (OSC1) High or Low Time	10	—	ns	EC Oscillator mode
4	TosR, TosF	External Clock in (OSC1) Rise or Fall Time	—	7.5	ns	EC Oscillator mode

Note 1: Instruction cycle period (Tcy) equals four times the input oscillator time base period for all configurations except PLL. All specified values are based on characterization data for that particular oscillator type under standard operating conditions with the device executing code. Exceeding these specified limits may result in an unstable oscillator operation and/or higher than expected current consumption. All devices are tested to operate at “min.” values with an external clock applied to the OSC1/CLKI pin. When an external clock input is used, the “max.” cycle time limit is “DC” (no clock) for all devices.

PIC18F85J90 FAMILY

TABLE 25-8: PLL CLOCK TIMING SPECIFICATIONS (V_{DD} = 2.15V TO 3.6V)

Param No.	Sym	Characteristic	Min	Typ†	Max	Units	Conditions
F10	FOSC	Oscillator Frequency Range	4	—	10	MHz	HS mode only
F11	FSYS	On-Chip VCO System Frequency	16	—	40	MHz	HS mode only
F12	t _{rc}	PLL Start-up Time (Lock Time)	—	—	2	ms	
F13	ΔCLK	CLKO Stability (Jitter)	-2	—	+2	%	

† Data in “Typ” column is at 3.3V, 25°C, unless otherwise stated. These parameters are for design guidance only and are not tested.

TABLE 25-9: INTERNAL RC ACCURACY (INTOSC AND INTRC SOURCES)

PIC18F85J90 Family (Industrial)		Standard Operating Conditions (unless otherwise stated) Operating temperature -40°C ≤ TA ≤ +85°C for industrial					
Param No.	Device	Min	Typ	Max	Units	Conditions	
INTOSC Accuracy @ Freq = 8 MHz, 4 MHz, 2 MHz, 1 MHz, 500 kHz, 250 kHz, 125 kHz, 31 kHz⁽¹⁾							
	All Devices	-2	+/-1	2	%	+25°C	V _{DD} = 2.7-3.3V
		-5	—	5	%	-10°C to +85°C	V _{DD} = 2.0-3.3V
		-10	+/-1	10	%	-40°C to +85°C	V _{DD} = 2.0-3.3V
INTRC Accuracy @ Freq = 31 kHz⁽¹⁾							
	All Devices	26.562	—	35.938	kHz	-40°C to +85°C	V _{DD} = 2.0-3.3V

Note 1: The accuracy specification of the 31 kHz clock is determined by which source is providing it at a given time. When INTSRC (OSCTUNE<7>) is ‘1’, use the INTOSC accuracy specification. When INTSRC is ‘0’, use the INTRC accuracy specification.

PIC18F85J90 FAMILY

FIGURE 25-5: CLKO AND I/O TIMING

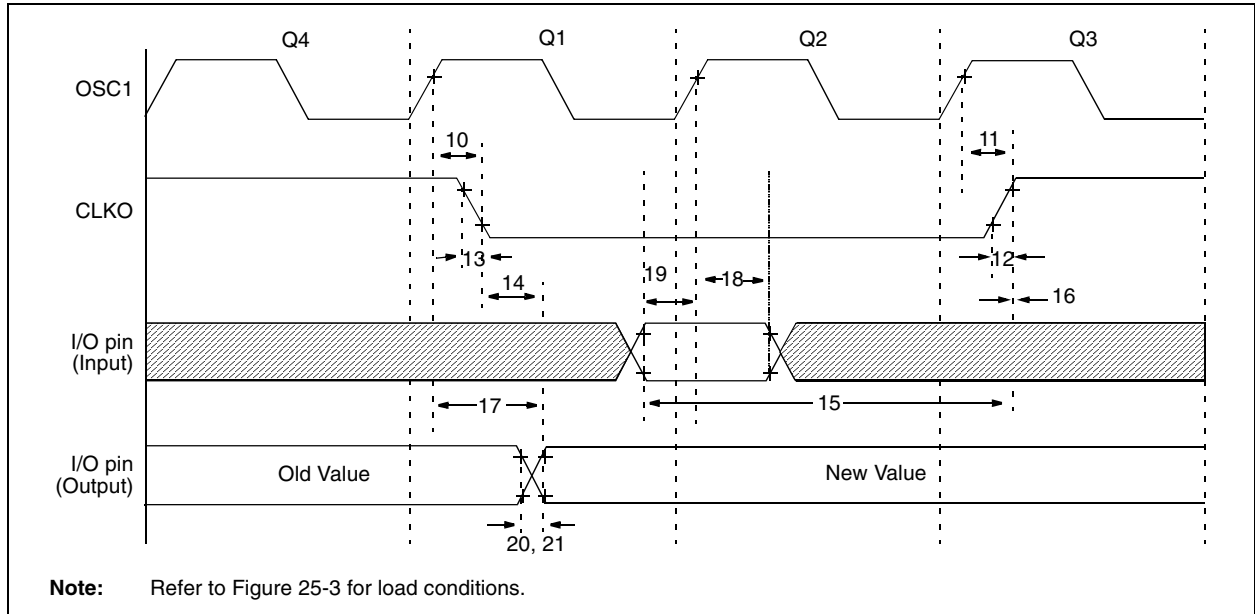

TABLE 25-10: CLKO AND I/O TIMING REQUIREMENTS

Param No.	Symbol	Characteristic	Min	Typ	Max	Units	Conditions
10	TosH2ckL	OSC1 ↑ to CLKO ↓	—	75	200	ns	(Note 1)
11	TosH2ckH	OSC1 ↑ to CLKO ↑	—	75	200	ns	(Note 1)
12	TckR	CLKO Rise Time	—	15	30	ns	(Note 1)
13	TckF	CLKO Fall Time	—	15	30	ns	(Note 1)
14	TckL2ioV	CLKO ↓ to Port Out Valid	—	—	0.5 T _{CY} + 20	ns	
15	TioV2ckH	Port In Valid before CLKO ↑	0.25 T _{CY} + 25	—	—	ns	
16	TckH2ioI	Port In Hold after CLKO ↑	0	—	—	ns	
17	TosH2ioV	OSC1 ↑ (Q1 cycle) to Port Out Valid	—	50	150	ns	
18	TosH2ioI	OSC1 ↑ (Q2 cycle) to Port Input Invalid (I/O in hold time)	100	—	—	ns	
19	TioV2osH	Port Input Valid to OSC1 ↑ (I/O in setup time)	0	—	—	ns	
20	TioR	Port Output Rise Time	—	—	6	ns	
21	TioF	Port Output Fall Time	—	—	5	ns	
22†	TINP	INT pin High or Low Time	T _{CY}	—	—	ns	
23†	TRBP	RB7:RB4 Change INT High or Low Time	T _{CY}	—	—	ns	

† These parameters are asynchronous events not related to any internal clock edges.

Note 1: Measurements are taken in EC mode, where CLKO output is 4 x T_{osc}.

PIC18F85J90 FAMILY

FIGURE 25-6: RESET, WATCHDOG TIMER, OSCILLATOR START-UP TIMER AND POWER-UP TIMER TIMING

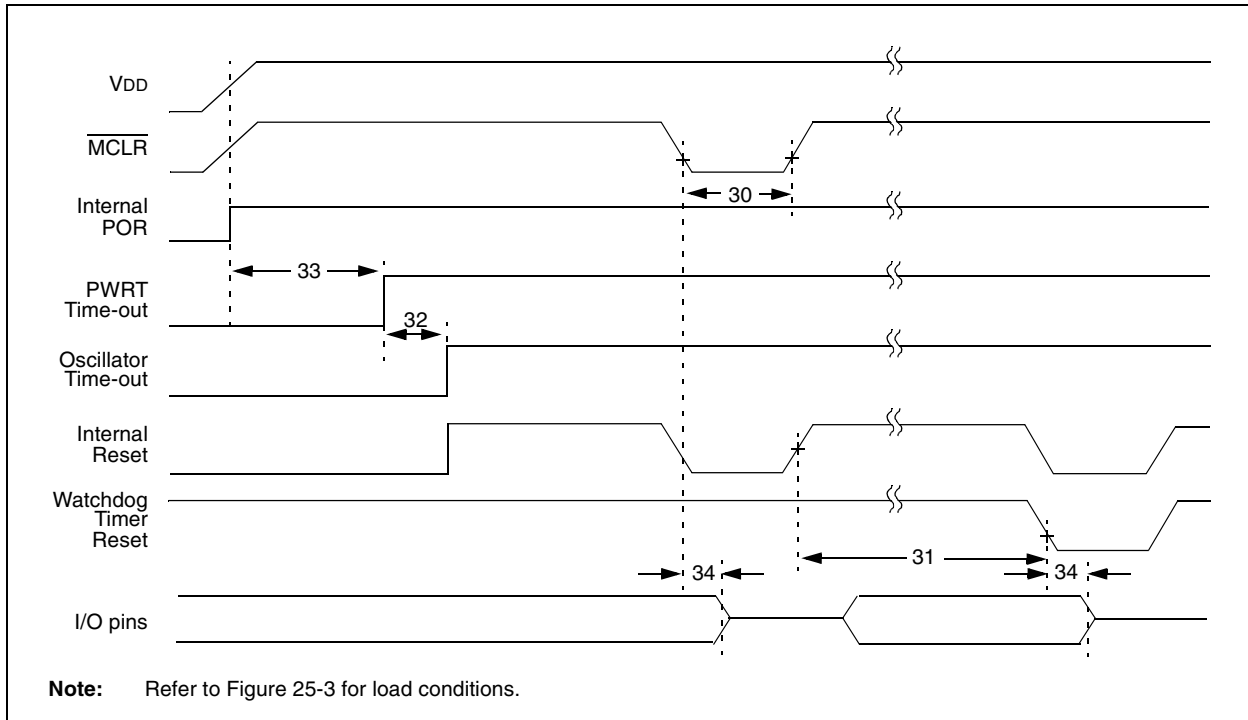

TABLE 25-11: RESET, WATCHDOG TIMER, OSCILLATOR START-UP TIMER, POWER-UP TIMER AND BROWN-OUT RESET REQUIREMENTS

Param. No.	Symbol	Characteristic	Min	Typ	Max	Units	Conditions
30	T _{MCL}	MCLR Pulse Width (low)	2 T _{CY}	10 T _{CY}	—		(Note 1)
31	T _{WDT}	Watchdog Timer Time-out Period (no postscaler)	3.4	4.0	4.6	ms	
32	T _{OSt}	Oscillation Start-up Timer Period	1024 T _{osc}	—	1024 T _{osc}	—	T _{osc} = OSC1 period
33	T _{PWRT}	Power-up Timer Period	45.8	65.5	85.2	ms	
34	T _{IOZ}	I/O High-Impedance from MCLR Low or Watchdog Timer Reset	—	2	—	μs	
38	T _{CSD}	CPU Start-up Time	—	10	—	μs	Voltage Regulator enabled and put to sleep
				200		μs	
39	T _{IOBST}	Time for INTOSC to Stabilize	—	1	—	μs	

Note 1: To ensure device Reset, MCLR must be low for at least 2 T_{CY} or 400 μs, whichever is lower.

PIC18F85J90 FAMILY

FIGURE 25-7: TIMER0 AND TIMER1 EXTERNAL CLOCK TIMINGS

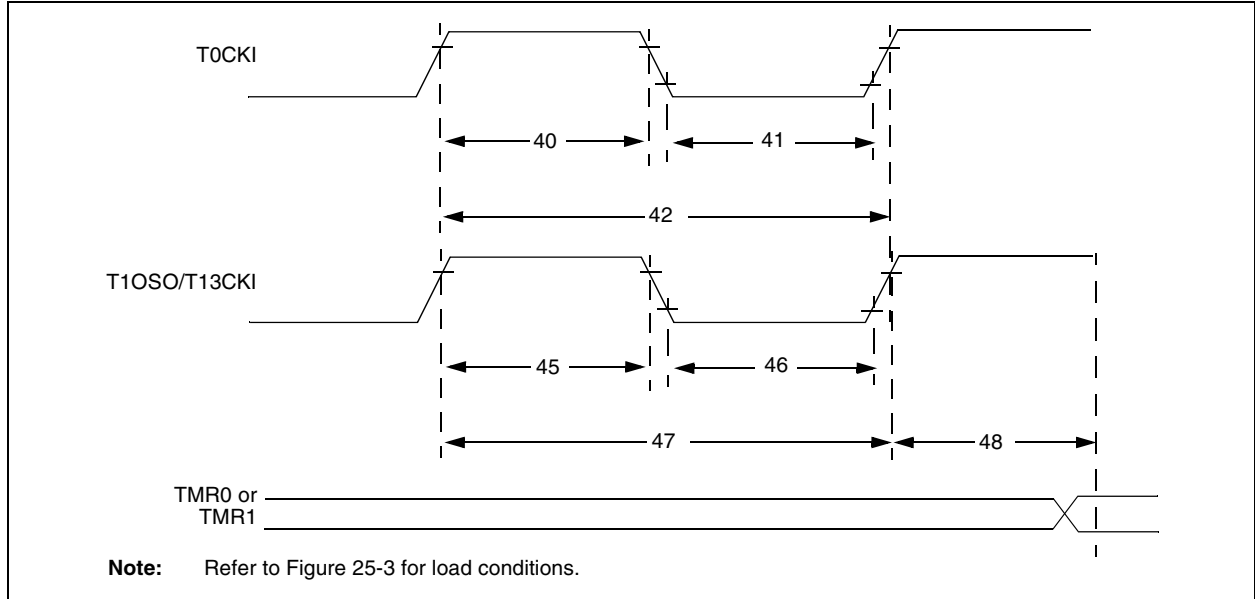

TABLE 25-12: TIMER0 AND TIMER1 EXTERNAL CLOCK REQUIREMENTS

Param No.	Symbol	Characteristic		Min	Max	Units	Conditions
40	TT0H	T0CKI High Pulse Width	No prescaler	$0.5 T_{CY} + 20$	—	ns	
			With prescaler	10	—	ns	
41	TT0L	T0CKI Low Pulse Width	No prescaler	$0.5 T_{CY} + 20$	—	ns	
			With prescaler	10	—	ns	
42	TT0P	T0CKI Period	No prescaler	$T_{CY} + 10$	—	ns	N = prescale value (1, 2, 4, ..., 256)
			With prescaler	Greater of: 20 ns or $(T_{CY} + 40)/N$	—	ns	
45	TT1H	T13CKI High Time	Synchronous, no prescaler	$0.5 T_{CY} + 20$	—	ns	
			Synchronous, with prescaler	10	—	ns	
			Asynchronous	30	—	ns	
46	TT1L	T13CKI Low Time	Synchronous, no prescaler	$0.5 T_{CY} + 5$	—	ns	
			Synchronous, with prescaler	10	—	ns	
			Asynchronous	30	—	ns	
47	TT1P	T13CKI Input Period	Synchronous	Greater of: 20 ns or $(T_{CY} + 40)/N$	—	ns	N = prescale value (1, 2, 4, 8)
			Asynchronous	60	—	ns	
	FT1	T13CKI Oscillator Input Frequency Range		DC	50	kHz	
48	TCKE2TMR1	Delay from External T13CKI Clock Edge to Timer Increment		$2 T_{OSC}$	$7 T_{OSC}$	—	

PIC18F85J90 FAMILY

FIGURE 25-8: CAPTURE/COMPARE/PWM TIMINGS (CCP1, CCP2 MODULES)

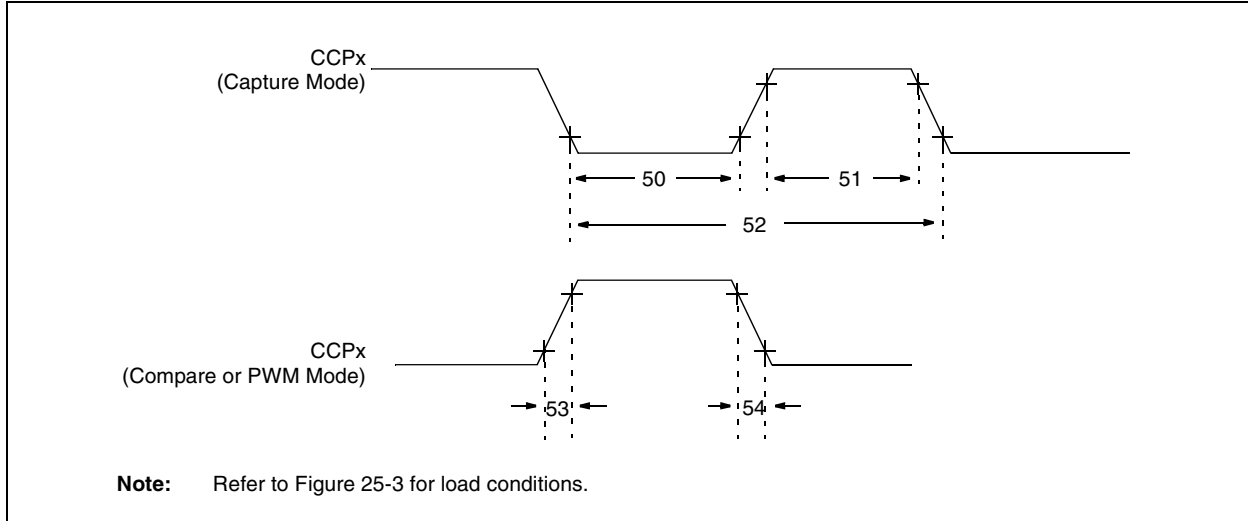

TABLE 25-13: CAPTURE/COMPARE/PWM REQUIREMENTS (CCP1, CCP2 MODULES)

Param No.	Symbol	Characteristic		Min	Max	Units	Conditions
50	TccL	CCPx Input Low Time	No prescaler	$0.5 T_{CY} + 20$	—	ns	
			With prescaler	10	—	ns	
51	TccH	CCPx Input High Time	No prescaler	$0.5 T_{CY} + 20$	—	ns	
			With prescaler	10	—	ns	
52	TccP	CCPx Input Period		$\frac{3 T_{CY} + 40}{N}$	—	ns	N = prescale value (1, 4 or 16)
53	TccR	CCPx Output Fall Time		—	25	ns	
54	TccF	CCPx Output Fall Time		—	25	ns	

PIC18F85J90 FAMILY

FIGURE 25-9: EXAMPLE SPI MASTER MODE TIMING (CKE = 0)

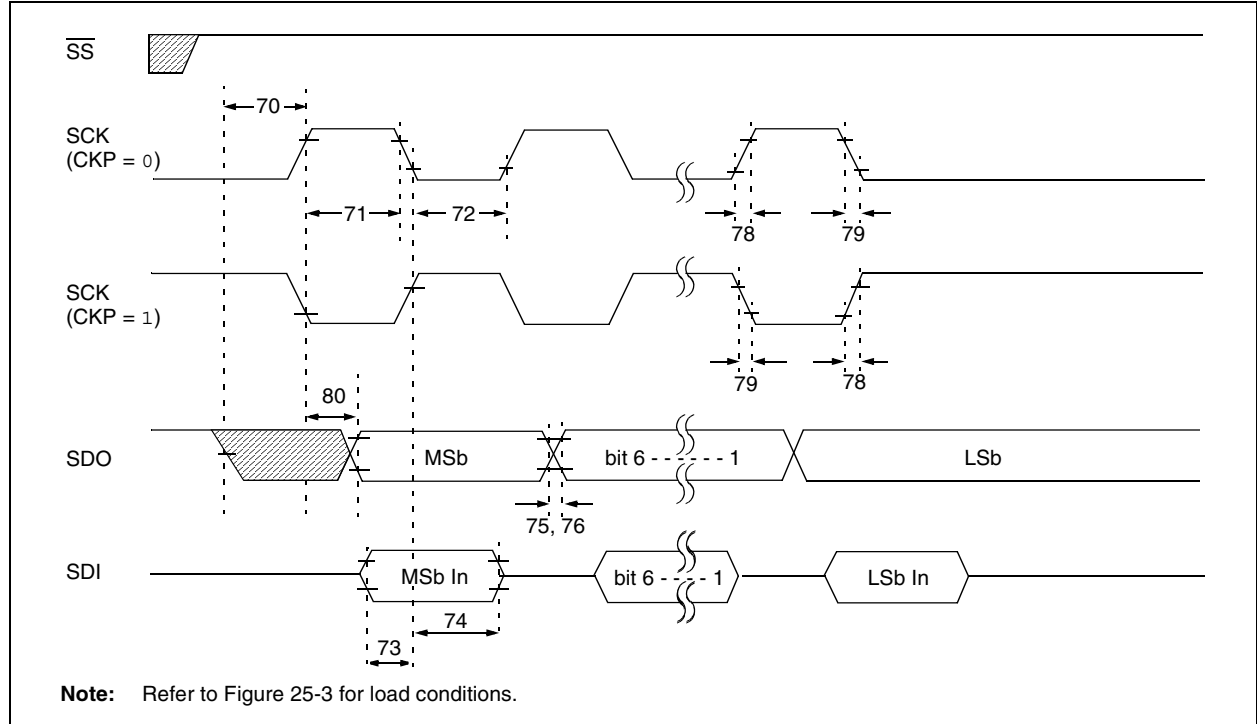

TABLE 25-14: EXAMPLE SPI MODE REQUIREMENTS (MASTER MODE, CKE = 0)

Param No.	Symbol	Characteristic	Min	Max	Units	Conditions
70	TssL2sCH, TssL2sCL	SS ↓ to SCK ↓ or SCK ↑ Input	T _{cy}	—	ns	
71	Tsch	SCK Input High Time (Slave mode)	Continuous	1.25 T _{cy} + 30	—	ns
71A			Single Byte	40	—	ns
72	TscL	SCK Input Low Time (Slave mode)	Continuous	1.25 T _{cy} + 30	—	ns
72A			Single Byte	40	—	ns
73	TdIV2sCH, TdIV2sCL	Setup Time of SDI Data Input to SCK Edge	100	—	ns	
73A	Tb2B	Last Clock Edge of Byte 1 to the 1st Clock Edge of Byte 2	1.5 T _{cy} + 40	—	ns	(Note 2)
74	Tsch2dIL, TscL2dIL	Hold Time of SDI Data Input to SCK Edge	100	—	ns	
75	TdoR	SDO Data Output Rise Time	—	25	ns	
76	TdoF	SDO Data Output Fall Time	—	25	ns	
78	TscR	SCK Output Rise Time (Master mode)	—	25	ns	
79	TscF	SCK Output Fall Time (Master mode)	—	25	ns	
80	Tsch2doV, TscL2doV	SDO Data Output Valid after SCK Edge	—	50	ns	

Note 1: Requires the use of Parameter #73A.

2: Only if Parameter #71A and #72A are used.

PIC18F85J90 FAMILY

FIGURE 25-10: EXAMPLE SPI MASTER MODE TIMING (CKE = 1)

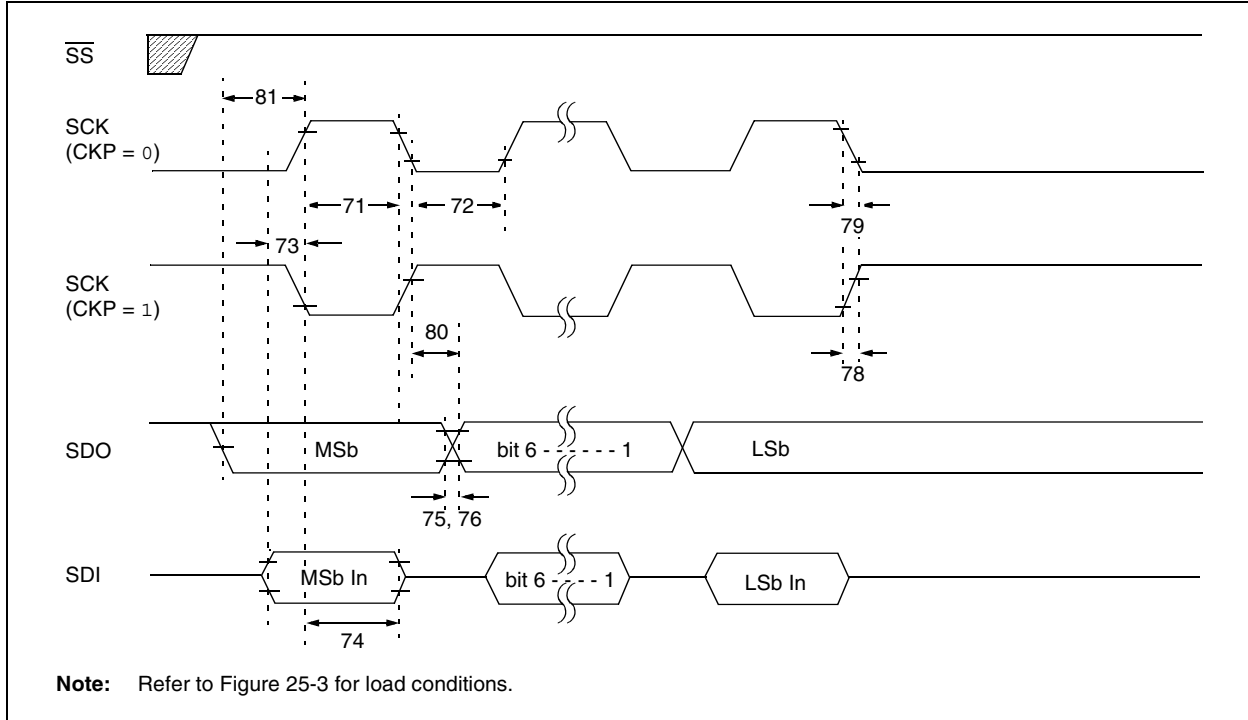

TABLE 25-15: EXAMPLE SPI MODE REQUIREMENTS (MASTER MODE, CKE = 1)

Param. No.	Symbol	Characteristic	Min	Max	Units	Conditions
71	Tsch	SCK Input High Time	1.25 Tcy + 30	—	ns	
71A		(Slave mode)				
		Continuous	1.25 Tcy + 30	—	ns	
		Single Byte	40	—	ns	(Note 1)
72	Tscl	SCK Input Low Time	1.25 Tcy + 30	—	ns	
72A		(Slave mode)				
		Continuous	1.25 Tcy + 30	—	ns	
		Single Byte	40	—	ns	(Note 1)
73	TdIV2sCH, TdIV2sCL	Setup Time of SDI Data Input to SCK Edge	100	—	ns	
73A	TB2B	Last Clock Edge of Byte 1 to the 1st Clock Edge of Byte 2	1.5 Tcy + 40	—	ns	(Note 2)
74	Tsch2dIL, Tscl2dIL	Hold Time of SDI Data Input to SCK Edge	100	—	ns	
75	TdoR	SDO Data Output Rise Time	—	25	ns	
76	TdoF	SDO Data Output Fall Time	—	25	ns	
78	TscR	SCK Output Rise Time (Master mode)	—	25	ns	
79	TscF	SCK Output Fall Time (Master mode)	—	25	ns	
80	Tsch2doV, Tscl2doV	SDO Data Output Valid after SCK Edge	—	50	ns	
81	TdoV2sCH, TdoV2sCL	SDO Data Output Setup to SCK Edge	Tcy	—	ns	

Note 1: Requires the use of Parameter #73A.

2: Only if Parameter #71A and #72A are used.

PIC18F85J90 FAMILY

FIGURE 25-11: EXAMPLE SPI SLAVE MODE TIMING (CKE = 0)

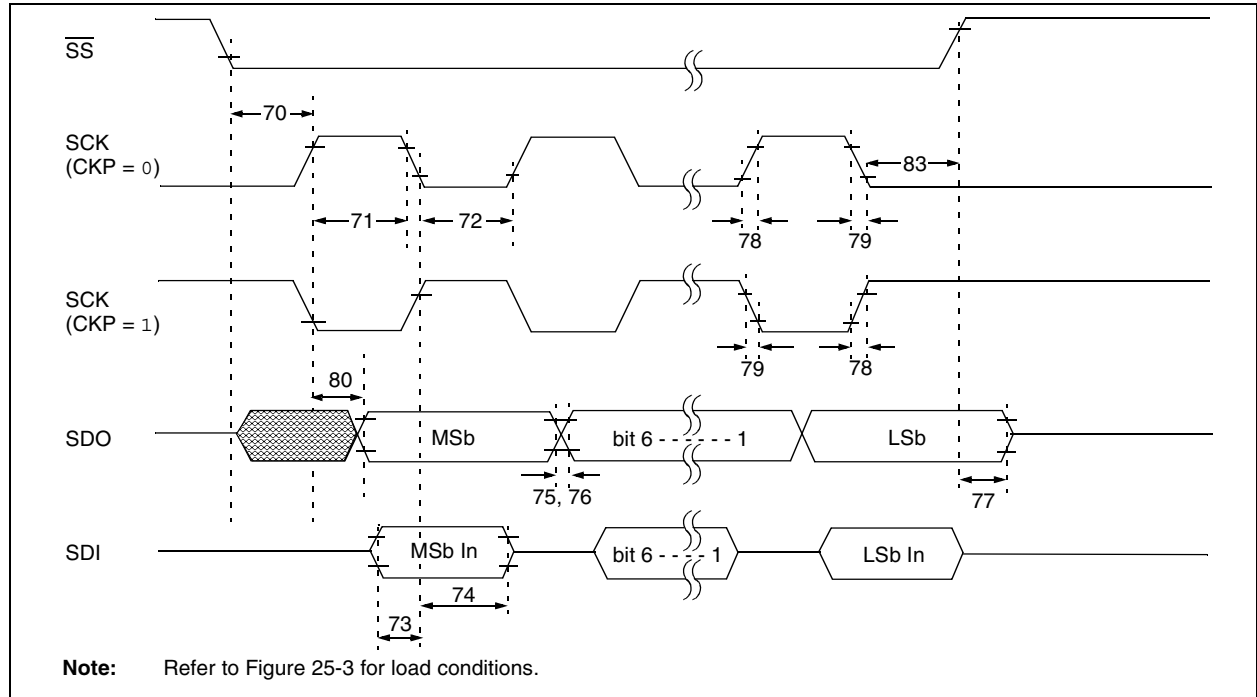

TABLE 25-16: EXAMPLE SPI MODE REQUIREMENTS (SLAVE MODE TIMING, CKE = 0)

Param No.	Symbol	Characteristic	Min	Max	Units	Conditions
70	TssL2scH, TssL2scL	$\overline{SS} \downarrow$ to SCK \downarrow or SCK \uparrow Input	3 Tcy	—	ns	
70A	TssL2WB	\overline{SS} to write to SSPBUF	3 Tcy	—	ns	
71	Tsch	SCK Input High Time (Slave mode)	Continuous	1.25 Tcy + 30	—	ns
71A			Single Byte	40	—	ns (Note 1)
72	Tscl	SCK Input Low Time (Slave mode)	Continuous	1.25 Tcy + 30	—	ns
72A			Single Byte	40	—	ns (Note 1)
73	TdIV2sch, TdIV2scl	Setup Time of SDI Data Input to SCK Edge	100	—	ns	
73A	Tb2B	Last Clock Edge of Byte 1 to the First Clock Edge of Byte 2	1.5 Tcy + 40	—	ns	(Note 2)
74	Tsch2dIL, TscL2dIL	Hold Time of SDI Data Input to SCK Edge	100	—	ns	
75	TdoR	SDO Data Output Rise Time	—	25	ns	
76	TdoF	SDO Data Output Fall Time	—	25	ns	
77	TssH2doZ	$\overline{SS} \uparrow$ to SDO Output High-impedance	10	50	ns	
78	TscR	SCK Output Rise Time (Master mode)	—	25	ns	
79	TscF	SCK Output Fall Time (Master mode)	—	25	ns	
80	Tsch2doV, TscL2doV	SDO Data Output Valid after SCK Edge	—	50	ns	
83	Tsch2ssH, TscL2ssH	$\overline{SS} \uparrow$ after SCK Edge	1.5 Tcy + 40	—	ns	

Note 1: Requires the use of Parameter #73A.

2: Only if Parameter #71A and #72A are used.

PIC18F85J90 FAMILY

FIGURE 25-12: EXAMPLE SPI SLAVE MODE TIMING (CKE = 1)

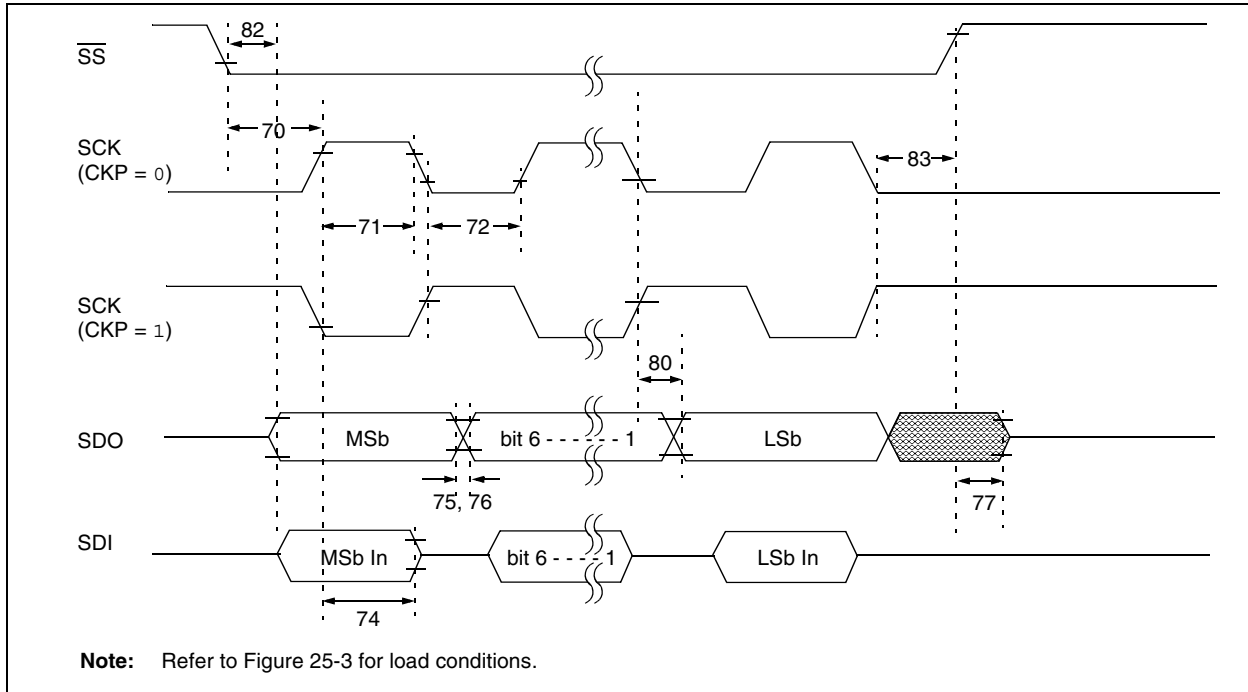

TABLE 25-17: EXAMPLE SPI SLAVE MODE REQUIREMENTS (CKE = 1)

Param No.	Symbol	Characteristic	Min	Max	Units	Conditions
70	TssL2sclH, TssL2sclL	$\overline{SS} \downarrow$ to SCK \downarrow or SCK \uparrow Input	3 T _{CY}	—	ns	
70A	TssL2WB	\overline{SS} to write to SSPBUF	3 T _{CY}	—	ns	
71	Tsch	SCK Input High Time (Slave mode)	Continuous	1.25 T _{CY} + 30	—	ns
71A			Single Byte	40	—	ns
72	TscL	SCK Input Low Time (Slave mode)	Continuous	1.25 T _{CY} + 30	—	ns
72A			Single Byte	40	—	ns
73A	Tb2B	Last Clock Edge of Byte 1 to the First Clock Edge of Byte 2	1.5 T _{CY} + 40	—	ns	(Note 2)
74	Tsch2diL, TscL2diL	Hold Time of SDI Data Input to SCK Edge	100	—	ns	
75	TdOR	SDO Data Output Rise Time	—	25	ns	
76	TdOF	SDO Data Output Fall Time	—	25	ns	
77	TssH2doZ	$\overline{SS} \uparrow$ to SDO Output High-Impedance	10	50	ns	
78	TscR	SCK Output Rise Time (Master mode)	—	25	ns	
79	TscF	SCK Output Fall Time (Master mode)	—	25	ns	
80	Tsch2doV, TscL2doV	SDO Data Output Valid after SCK Edge	—	50	ns	
82	TssL2doV	SDO Data Output Valid after $\overline{SS} \downarrow$ Edge	—	50	ns	
83	Tsch2ssH, TscL2ssH	$\overline{SS} \uparrow$ after SCK Edge	1.5 T _{CY} + 40	—	ns	

Note 1: Requires the use of Parameter #73A.

Note 2: Only if Parameter #71A and #72A are used.

PIC18F85J90 FAMILY

FIGURE 25-13: I²C™ BUS START/STOP BITS TIMING

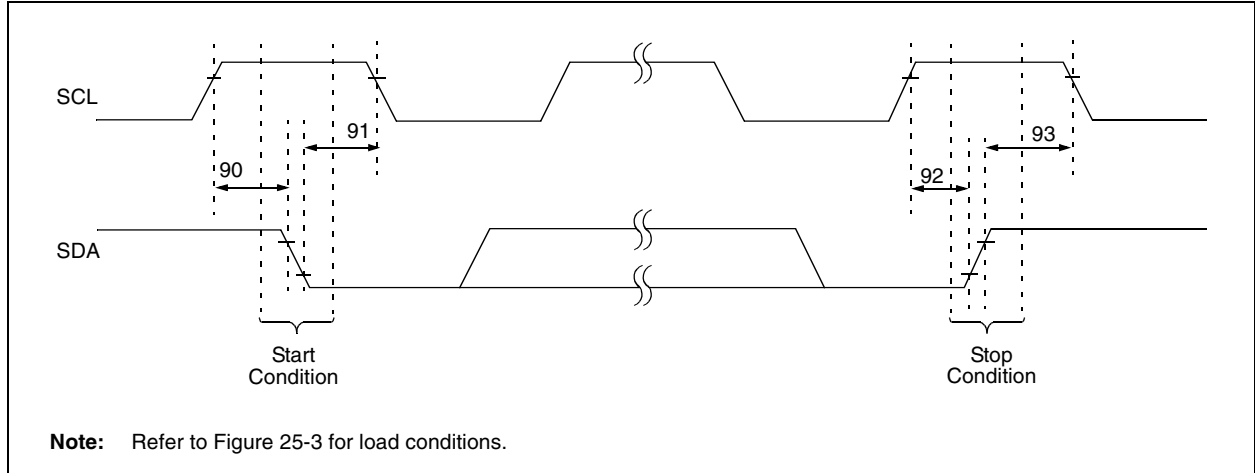
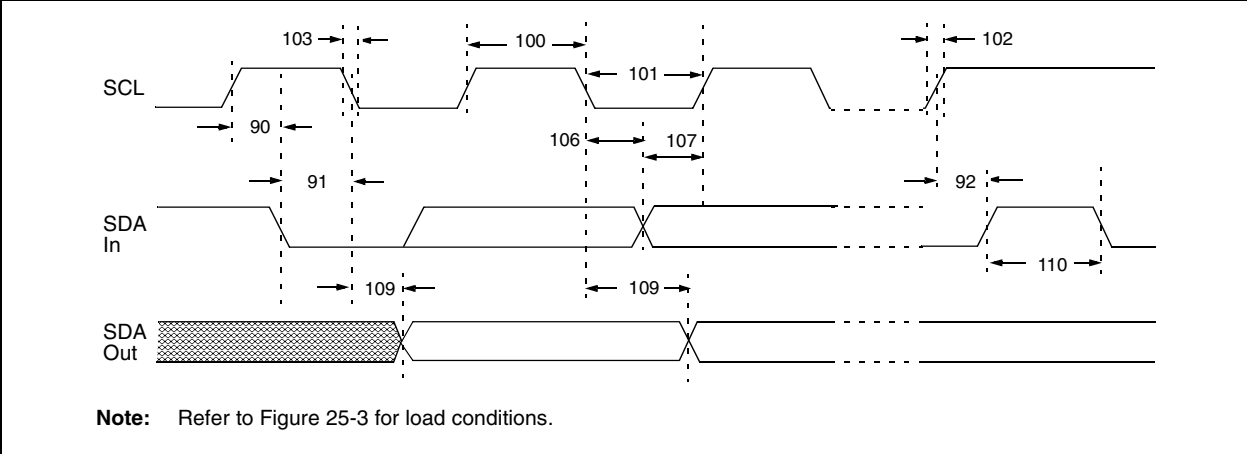

TABLE 25-18: I²C™ BUS START/STOP BITS REQUIREMENTS (SLAVE MODE)

Param. No.	Symbol	Characteristic	Min	Max	Units	Conditions	
90	TSU:STA	Start Condition Setup Time	100 kHz mode	4700	—	ns	Only relevant for Repeated Start condition
			400 kHz mode	600	—		
91	THD:STA	Start Condition Hold Time	100 kHz mode	4000	—	ns	After this period, the first clock pulse is generated
			400 kHz mode	600	—		
92	TSU:STO	Stop Condition Setup Time	100 kHz mode	4700	—	ns	
			400 kHz mode	600	—		
93	THD:STO	Stop Condition Hold Time	100 kHz mode	4000	—	ns	
			400 kHz mode	600	—		

PIC18F85J90 FAMILY

FIGURE 25-14: I²C™ BUS DATA TIMING



PIC18F85J90 FAMILY

TABLE 25-19: I²C™ BUS DATA REQUIREMENTS (SLAVE MODE)

Param. No.	Symbol	Characteristic	Min	Max	Units	Conditions
100	THIGH	Clock High Time	100 kHz mode	4.0	—	μs
			400 kHz mode	0.6	—	μs
			MSSP Module	1.5 T _{CY}	—	
101	TLOW	Clock Low Time	100 kHz mode	4.7	—	μs
			400 kHz mode	1.3	—	μs
			MSSP Module	1.5 T _{CY}	—	
102	TR	SDA and SCL Rise Time	100 kHz mode	—	1000	ns
			400 kHz mode	20 + 0.1 C _B	300	ns
103	TF	SDA and SCL Fall Time	100 kHz mode	—	300	ns
			400 kHz mode	20 + 0.1 C _B	300	ns
90	TSU:STA	Start Condition Setup Time	100 kHz mode	4.7	—	μs
			400 kHz mode	0.6	—	μs
91	THD:STA	Start Condition Hold Time	100 kHz mode	4.0	—	μs
			400 kHz mode	0.6	—	μs
106	THD:DAT	Data Input Hold Time	100 kHz mode	0	—	ns
			400 kHz mode	0	0.9	μs
107	TSU:DAT	Data Input Setup Time	100 kHz mode	250	—	ns
			400 kHz mode	100	—	ns
92	TSU:STO	Stop Condition Setup Time	100 kHz mode	4.7	—	μs
			400 kHz mode	0.6	—	μs
109	TAA	Output Valid from Clock	100 kHz mode	—	3500	ns
			400 kHz mode	—	—	ns
110	TBUF	Bus Free Time	100 kHz mode	4.7	—	μs
			400 kHz mode	1.3	—	μs
D102	C _B	Bus Capacitive Loading	—	400	pF	

Note 1: As a transmitter, the device must provide this internal minimum delay time to bridge the undefined region (min. 300 ns) of the falling edge of SCL to avoid unintended generation of Start or Stop conditions.

- 2:** A Fast mode I²C™ bus device can be used in a Standard mode I²C bus system, but the requirement, TSU:DAT ≥ 250 ns, must then be met. This will automatically be the case if the device does not stretch the LOW period of the SCL signal. If such a device does stretch the LOW period of the SCL signal, it must output the next data bit to the SDA line, TR max. + TSU:DAT = 1000 + 250 = 1250 ns (according to the Standard mode I²C bus specification), before the SCL line is released.

PIC18F85J90 FAMILY

FIGURE 25-15: MSSP I²C™ BUS START/STOP BITS TIMING WAVEFORMS

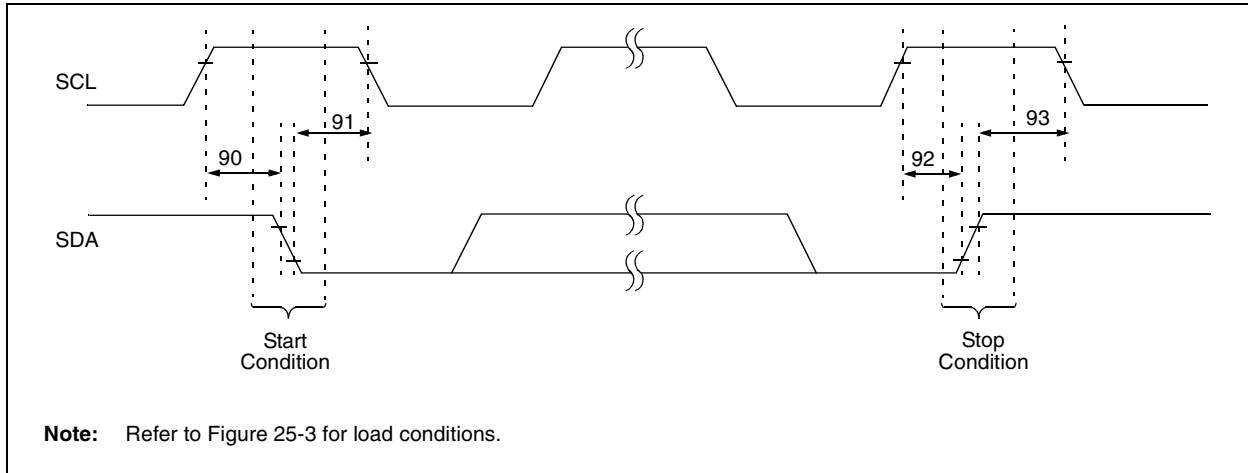
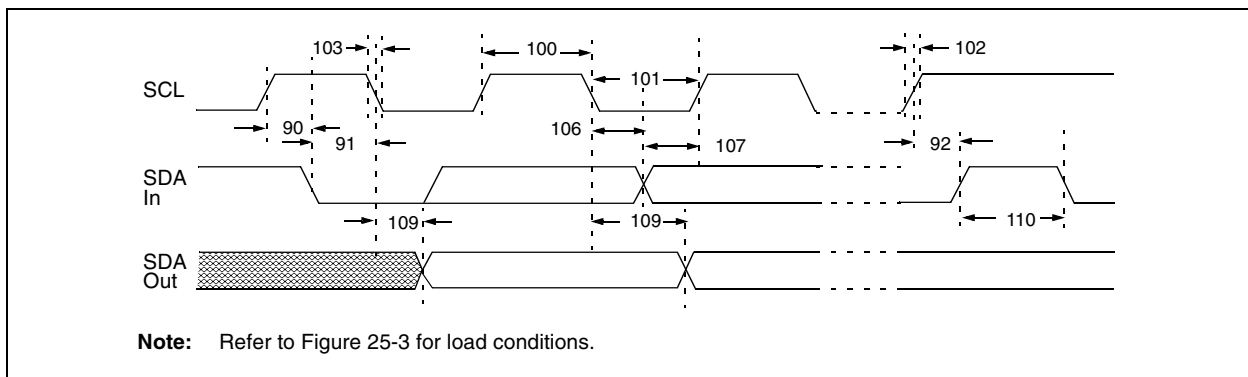

TABLE 25-20: MSSP I²C™ BUS START/STOP BITS REQUIREMENTS

Param. No.	Symbol	Characteristic		Min	Max	Units	Conditions
90	TSU:STA	Start Condition Setup Time	100 kHz mode	$2(T_{osc})(BRG + 1)$	—	ns	Only relevant for Repeated Start condition
			400 kHz mode	$2(T_{osc})(BRG + 1)$	—		
			1 MHz mode ⁽¹⁾	$2(T_{osc})(BRG + 1)$	—		
91	THD:STA	Start Condition Hold Time	100 kHz mode	$2(T_{osc})(BRG + 1)$	—	ns	After this period, the first clock pulse is generated
			400 kHz mode	$2(T_{osc})(BRG + 1)$	—		
			1 MHz mode ⁽¹⁾	$2(T_{osc})(BRG + 1)$	—		
92	TSU:STO	Stop Condition Setup Time	100 kHz mode	$2(T_{osc})(BRG + 1)$	—	ns	
			400 kHz mode	$2(T_{osc})(BRG + 1)$	—		
			1 MHz mode ⁽¹⁾	$2(T_{osc})(BRG + 1)$	—		
93	THD:STO	Stop Condition Hold Time	100 kHz mode	$2(T_{osc})(BRG + 1)$	—	ns	
			400 kHz mode	$2(T_{osc})(BRG + 1)$	—		
			1 MHz mode ⁽¹⁾	$2(T_{osc})(BRG + 1)$	—		

Note 1: Maximum pin capacitance = 10 pF for all I²C™ pins.

FIGURE 25-16: MSSP I²C™ BUS DATA TIMING



PIC18F85J90 FAMILY

TABLE 25-21: MSSP I²C™ BUS DATA REQUIREMENTS

Param. No.	Symbol	Characteristic	Min	Max	Units	Conditions
100	THIGH	Clock High Time	100 kHz mode	2(Tosc)(BRG + 1)	—	ms
			400 kHz mode	2(Tosc)(BRG + 1)	—	ms
			1 MHz mode ⁽¹⁾	2(Tosc)(BRG + 1)	—	ms
101	TLOW	Clock Low Time	100 kHz mode	2(Tosc)(BRG + 1)	—	ms
			400 kHz mode	2(Tosc)(BRG + 1)	—	ms
			1 MHz mode ⁽¹⁾	2(Tosc)(BRG + 1)	—	ms
102	TR	SDA and SCL Rise Time	100 kHz mode	—	1000	ns
			400 kHz mode	20 + 0.1 CB	300	ns
			1 MHz mode ⁽¹⁾	—	300	ns
103	TF	SDA and SCL Fall Time	100 kHz mode	—	300	ns
			400 kHz mode	20 + 0.1 CB	300	ns
			1 MHz mode ⁽¹⁾	—	100	ns
90	TSU:STA	Start Condition Setup Time	100 kHz mode	2(Tosc)(BRG + 1)	—	ms
			400 kHz mode	2(Tosc)(BRG + 1)	—	ms
			1 MHz mode ⁽¹⁾	2(Tosc)(BRG + 1)	—	ms
91	THD:STA	Start Condition Hold Time	100 kHz mode	2(Tosc)(BRG + 1)	—	ms
			400 kHz mode	2(Tosc)(BRG + 1)	—	ms
			1 MHz mode ⁽¹⁾	2(Tosc)(BRG + 1)	—	ms
106	THD:DAT	Data Input Hold Time	100 kHz mode	0	—	ns
			400 kHz mode	0	0.9	ms
			1 MHz mode ⁽¹⁾	TBD	—	ns
107	TSU:DAT	Data Input Setup Time	100 kHz mode	250	—	ns
			400 kHz mode	100	—	ns
			1 MHz mode ⁽¹⁾	TBD	—	ns
92	TSU:STO	Stop Condition Setup Time	100 kHz mode	2(Tosc)(BRG + 1)	—	ms
			400 kHz mode	2(Tosc)(BRG + 1)	—	ms
			1 MHz mode ⁽¹⁾	2(Tosc)(BRG + 1)	—	ms
109	TAA	Output Valid from Clock	100 kHz mode	—	3500	ns
			400 kHz mode	—	1000	ns
			1 MHz mode ⁽¹⁾	—	—	ns
110	TBUF	Bus Free Time	100 kHz mode	4.7	—	ms
			400 kHz mode	1.3	—	ms
			1 MHz mode ⁽¹⁾	TBD	—	ms
D102	CB	Bus Capacitive Loading	—	400	pF	

Legend: TBD = To Be Determined

Note 1: Maximum pin capacitance = 10 pF for all I²C™ pins.

- 2:** A Fast mode I²C bus device can be used in a Standard mode I²C bus system, but parameter #107 ≥ 250 ns must then be met. This will automatically be the case if the device does not stretch the LOW period of the SCL signal. If such a device does stretch the LOW period of the SCL signal, it must output the next data bit to the SDA line, parameter #102 + parameter #107 = 1000 + 250 = 1250 ns (for 100 kHz mode), before the SCL line is released.

PIC18F85J90 FAMILY

FIGURE 25-17: EUSART/AUSART SYNCHRONOUS TRANSMISSION (MASTER/SLAVE) TIMING

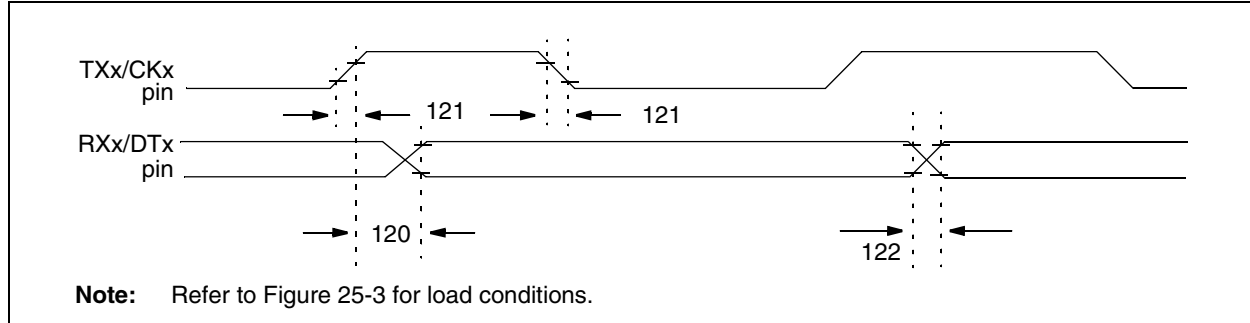

TABLE 25-22: EUSART/AUSART SYNCHRONOUS TRANSMISSION REQUIREMENTS

Param No.	Symbol	Characteristic	Min	Max	Units	Conditions
120	TCKH2DTV	SYNC XMIT (MASTER and SLAVE) Clock High to Data Out Valid	—	40	ns	
121	TCKRF	Clock Out Rise Time and Fall Time (Master mode)	—	20	ns	
122	TDTRF	Data Out Rise Time and Fall Time	—	20	ns	

FIGURE 25-18: EUSART/AUSART SYNCHRONOUS RECEIVE (MASTER/SLAVE) TIMING

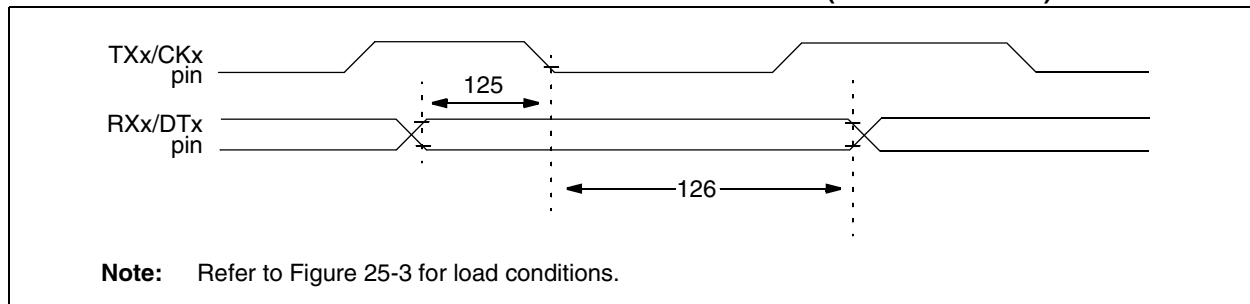

TABLE 25-23: EUSART/AUSART SYNCHRONOUS RECEIVE REQUIREMENTS

Param. No.	Symbol	Characteristic	Min	Max	Units	Conditions
125	TDTV2CKL	SYNC RCV (MASTER and SLAVE) Data Hold before CKx ↓ (DTx hold time)	10	—	ns	
126	TCKL2DTL	Data Hold after CKx ↓ (DTx hold time)	15	—	ns	

PIC18F85J90 FAMILY

TABLE 25-24: A/D CONVERTER CHARACTERISTICS: PIC18F85J90 FAMILY (INDUSTRIAL)

Param No.	Symbol	Characteristic	Min	Typ	Max	Units	Conditions
A01	NR	Resolution	—	—	10	bits	
A03	EIL	Integral Linearity Error	—	—	$<\pm 1$	LSb	$\Delta V_{REF} \geq 3.0V$
A04	EDL	Differential Linearity Error	—	—	$<\pm 1$	LSb	$\Delta V_{REF} \geq 3.0V$
A06	E _{OFF}	Offset Error	—	—	$<\pm 3$	LSb	$\Delta V_{REF} \geq 3.0V$
A07	E _{GN}	Gain Error	—	—	$<\pm 3$	LSb	$\Delta V_{REF} \geq 3.0V$
A10	—	Monotonicity	Guaranteed ⁽¹⁾			—	$V_{SS} \leq V_{AIN} \leq V_{REF}$
A20	ΔV_{REF}	Reference Voltage Range ($V_{REFH} - V_{REFL}$)	2.0	—	—	V	$V_{DD} < 3.0V$
			3	—	—	V	$V_{DD} \geq 3.0V$
A21	V_{REFH}	Reference Voltage High	V_{SS}	—	V_{REFH}	V	
A22	V_{REFL}	Reference Voltage Low	$V_{SS} - 0.3V$	—	$V_{DD} - 3.0V$	V	
A25	V_{AIN}	Analog Input Voltage	V_{REFL}	—	V_{REFH}	V	
A30	Z_{AIN}	Recommended Impedance of Analog Voltage Source	—	—	2.5	k Ω	
A50	I _{REF}	V_{REF} Input Current ⁽²⁾	—	—	5	μA	During V_{AIN} acquisition.
			—	—	150	μA	During A/D conversion cycle.

Note 1: The A/D conversion result never decreases with an increase in the input voltage and has no missing codes.

- 2:** V_{REFH} current is from RA3/AN3/ V_{REF+} pin or V_{DD} , whichever is selected as the V_{REFH} source.
 V_{REFL} current is from RA2/AN2/ V_{REF-} pin or V_{SS} , whichever is selected as the V_{REFL} source.

PIC18F85J90 FAMILY

FIGURE 25-19: A/D CONVERSION TIMING

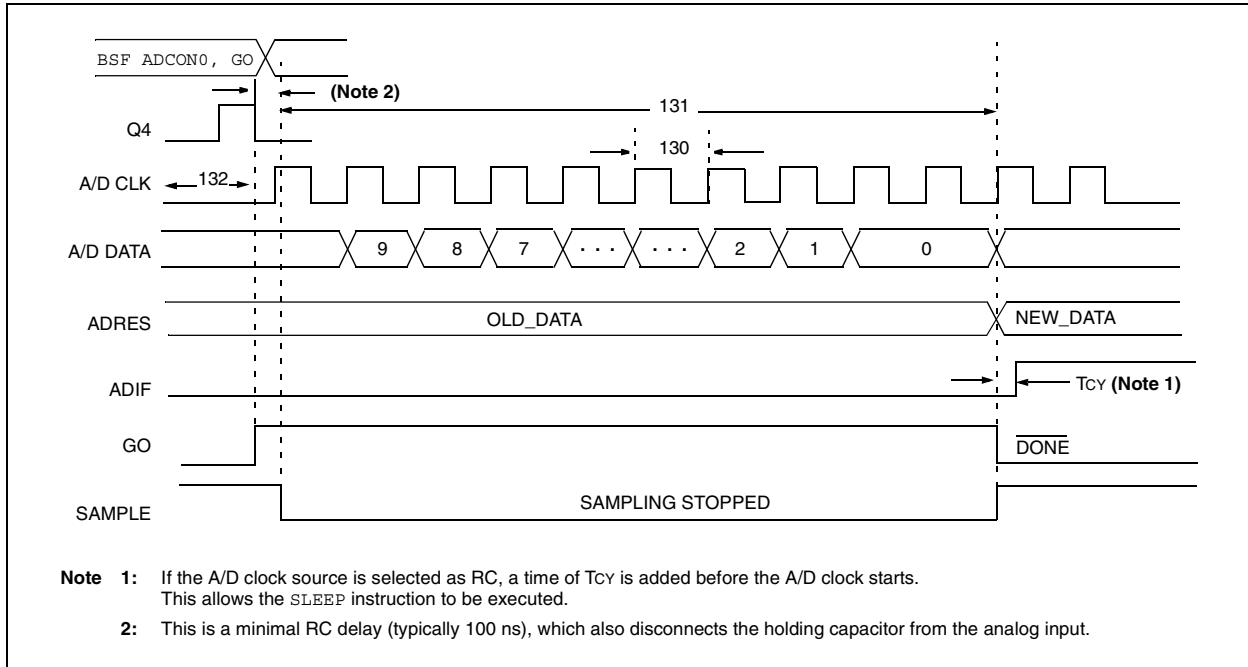

TABLE 25-25: A/D CONVERSION REQUIREMENTS

Param No.	Symbol	Characteristic	Min	Max	Units	Conditions
130	TAD	A/D Clock Period	0.7	25.0 ⁽¹⁾	μ s	TOSC based, VREF \geq 3.0V
			TBD	1	μ s	A/D RC mode
131	TcNV	Conversion Time (not including acquisition time) ⁽²⁾	11	12	TAD	
132	TAcQ	Acquisition Time ⁽³⁾	1.4	—	μ s	-40°C to +85°C
135	TswC	Switching Time from Convert \rightarrow Sample	—	(Note 4)		
TBD	TDis	Discharge Time	0.2	—	μ s	

Legend: TBD = To Be Determined

- Note 1:** The time of the A/D clock period is dependent on the device frequency and the TAD clock divider.
- Note 2:** ADRES registers may be read on the following T_{cV} cycle.
- Note 3:** The time for the holding capacitor to acquire the “New” input voltage when the voltage changes full scale after the conversion (VDD to VSS or VSS to VDD). The source impedance (R_s) on the input channels is 50 Ω .
- Note 4:** On the following cycle of the device clock.

PIC18F85J90 FAMILY

NOTES:

26.0 DC AND AC CHARACTERISTICS GRAPHS AND TABLES

Graphs and tables are not available at this time.

PIC18F85J90 FAMILY

NOTES:

PIC18F85J90 FAMILY

27.0 PACKAGING INFORMATION

27.1 Package Marking Information

64-Lead TQFP

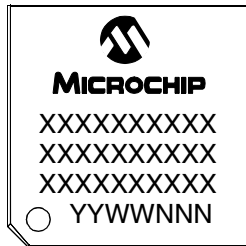

Example

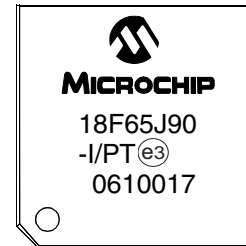

80-Lead TQFP

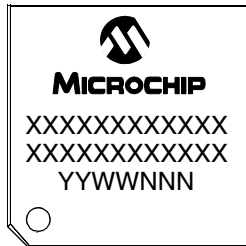

Example

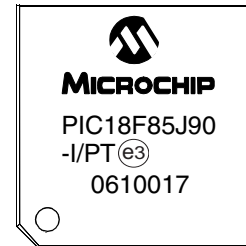

Legend:	XX...X	Customer-specific information
	Y	Year code (last digit of calendar year)
	YY	Year code (last 2 digits of calendar year)
	WW	Week code (week of January 1 is week '01')
	NNN	Alphanumeric traceability code
	(e3)	Pb-free JEDEC designator for Matte Tin (Sn)
	*	This package is Pb-free. The Pb-free JEDEC designator (e3) can be found on the outer packaging for this package.

Note: In the event the full Microchip part number cannot be marked on one line, it will be carried over to the next line, thus limiting the number of available characters for customer-specific information.

PIC18F85J90 FAMILY

27.2 Package Details

The following sections give the technical details of the packages.

64-Lead Plastic Thin Quad Flatpack (PT) – 10x10x1 mm Body, 2.00 mm Footprint [TQFP]

Note: For the most current package drawings, please see the Microchip Packaging Specification located at <http://www.microchip.com/packaging>

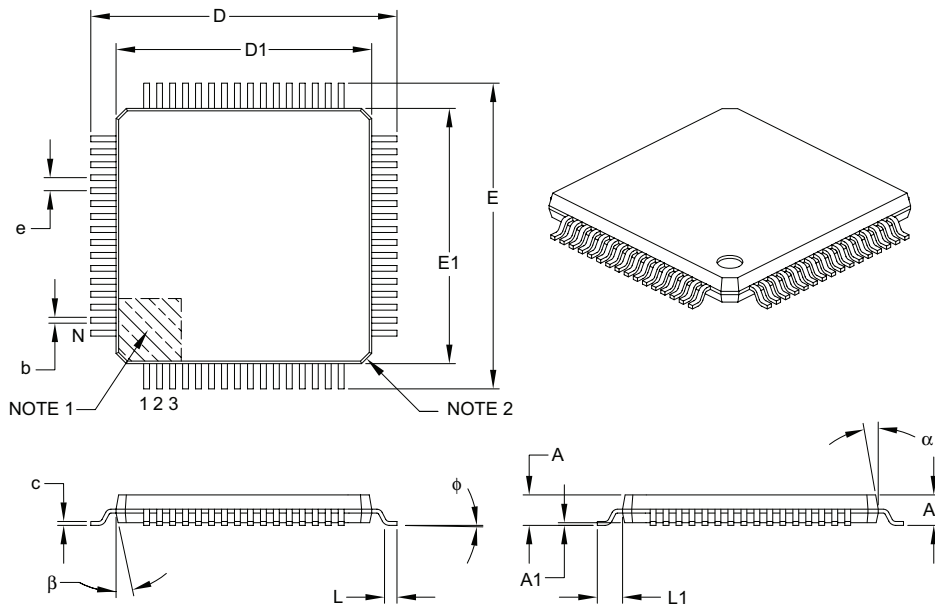

Dimension Limits	Units	MILLIMETERS		
		MIN	NOM	MAX
Number of Leads	N	64		
Lead Pitch	e	0.50 BSC		
Overall Height	A	–	–	1.20
Molded Package Thickness	A2	0.95	1.00	1.05
Standoff	A1	0.05	–	0.15
Foot Length	L	0.45	0.60	0.75
Footprint	L1	1.00 REF		
Foot Angle	ϕ	0°	3.5°	7°
Overall Width	E	12.00 BSC		
Overall Length	D	12.00 BSC		
Molded Package Width	E1	10.00 BSC		
Molded Package Length	D1	10.00 BSC		
Lead Thickness	c	0.09	–	0.20
Lead Width	b	0.17	0.22	0.27
Mold Draft Angle Top	α	11°	12°	13°
Mold Draft Angle Bottom	β	11°	12°	13°

Notes:

- Pin 1 visual index feature may vary, but must be located within the hatched area.
- Chamfers at corners are optional; size may vary.
- Dimensions D1 and E1 do not include mold flash or protrusions. Mold flash or protrusions shall not exceed 0.25 mm per side.
- Dimensioning and tolerancing per ASME Y14.5M.

BSC: Basic Dimension. Theoretically exact value shown without tolerances.

REF: Reference Dimension, usually without tolerance, for information purposes only.

Microchip Technology Drawing C04-085B

PIC18F85J90 FAMILY

80-Lead Plastic Thin Quad Flatpack (PT) – 12x12x1 mm Body, 2.00 mm Footprint [TQFP]

Note: For the most current package drawings, please see the Microchip Packaging Specification located at <http://www.microchip.com/packaging>

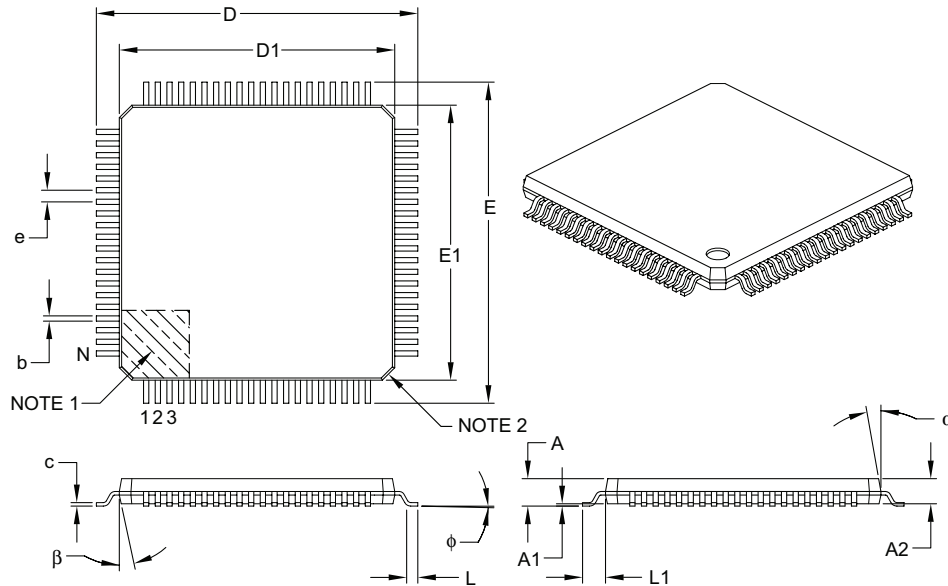

Dimension Limits	Units	MILLIMETERS		
		MIN	NOM	MAX
Number of Leads	N	80		
Lead Pitch	e	0.50 BSC		
Overall Height	A	–	–	1.20
Molded Package Thickness	A2	0.95	1.00	1.05
Standoff	A1	0.05	–	0.15
Foot Length	L	0.45	0.60	0.75
Footprint	L1	1.00 REF		
Foot Angle	φ	0°	3.5°	7°
Overall Width	E	14.00 BSC		
Overall Length	D	14.00 BSC		
Molded Package Width	E1	12.00 BSC		
Molded Package Length	D1	12.00 BSC		
Lead Thickness	c	0.09	–	0.20
Lead Width	b	0.17	0.22	0.27
Mold Draft Angle Top	α	11°	12°	13°
Mold Draft Angle Bottom	β	11°	12°	13°

Notes:

- Pin 1 visual index feature may vary, but must be located within the hatched area.
- Chamfers at corners are optional; size may vary.
- Dimensions D1 and E1 do not include mold flash or protrusions. Mold flash or protrusions shall not exceed 0.25 mm per side.
- Dimensioning and tolerancing per ASME Y14.5M.

BSC: Basic Dimension. Theoretically exact value shown without tolerances.

REF: Reference Dimension, usually without tolerance, for information purposes only.

Microchip Technology Drawing C04-092B

PIC18F85J90 FAMILY

NOTES:

PIC18F85J90 FAMILY

APPENDIX A: REVISION HISTORY

Revision A (July 2006)

Original data sheet for PIC18F85J90 family devices.

Revision B (March 2007)

Updated power-down and supply-current electrical characteristics and package details illustrations.

APPENDIX B: MIGRATION BETWEEN HIGH-END DEVICE FAMILIES

Devices in the PIC18F85J90 and PIC18F8490 families are very similar in their functions and feature sets. However, there are some potentially important differences which should be considered when migrating an application across device families to achieve a new design goal. These are summarized in Table B-1. The areas of difference, which could be a major impact on migration, are discussed in greater detail later in this section.

TABLE B-1: NOTABLE DIFFERENCES BETWEEN PIC18F8490 AND PIC18F85J90 FAMILIES

Characteristic	PIC18F85J90 Family	PIC18F8490 Family
Operating Frequency	40 MHz @ 2.15V	40 MHz @ 4.2V
Supply Voltage	2.0V-3.6V, Dual Voltage Requirement	2.0V-5.5V
Operating Current	Low	Lower
Program Memory Size (maximum)	32 Kbytes	16 Kbytes
Program Memory Endurance	10,000 Write/Erase Cycles (typical)	100,000 Write/Erase Cycles (typical)
Program Memory Retention	20 Years (minimum)	40 Years (minimum)
Programming Time (Normalized)	43.8 μ s/byte (2.8 ms/64-byte block)	15.6 μ s/byte (1 ms/64-byte block)
I/O Sink/Source at 25 mA	PORTB and PORTC Only	All Ports
Input Voltage Tolerance on I/O Pins	5.5V on Digital Only Pins	VDD on All I/O Pins
I/O	67	66
LCD Outputs (maximum pixels, segments x commons)	192	192
LCD Bias Generation	4 Modes	1 Mode
LCD Voltage Regulator	Implemented; Includes Voltage Boost	Not Available
Pull-ups	PORTB, PORTD, PORTE and PORTJ	PORTB
Open-Drain Output Option	Available on USARTs, SPI and CCP Output Pins	Not Available
Oscillator Options	Limited Primary Options (EC, HS, PLL); Flexible Internal Oscillator (INTOSC and INTRC)	More Primary Options (EC, HS, XT, LP, RC, PLL); Flexible Internal Oscillator (INTOSC and INTRC)
Programming Entry	Low Voltage, Key Sequence	VPP and LVP
Code Protection	Single Block, All or Nothing	Multiple Code Protection Blocks
Configuration Words	Stored in Last 4 Words of Program Memory space	Stored in Configuration Space, Starting at 300000h
Start-up Time from Sleep	200 μ s (typical)	10 μ s (typical)
	10 μ s (typical) with Voltage Regulator Disabled	
Power-up Timer	Always on	Configurable
Data EEPROM	Use Self-Programming	Not Available
BOR	Simple BOR with Voltage Regulator	Separate Programmable BOR
LVD	Integrated with Voltage Regulator	Separate Programmable Module
A/D Channels	12	12
A/D Calibration	Self-Calibration Feature	Software Look-up Table
In-Circuit Emulation	Not available	Available

PIC18F85J90 FAMILY

B.1 Power Requirement Differences

The most significant difference between the PIC18F85J90 and PIC18F8490 device families is the power requirements. PIC18F85J90 family devices are designed on a smaller process. This results in lower maximum voltage and higher leakage current.

The operating voltage range for PIC18F85J90 devices is 2.0V to 3.6V. In addition, these devices have split power requirements: one for the core logic and one for the I/O. One of the VDD pins is separated for the core logic supply (VDDCORE). This pin has specific voltage and capacitor requirements as described in **Section 25.0 “Electrical Characteristics”**.

B.2 Oscillator Differences

PIC18F8490 and PIC18F85J90 family devices share a similar range of oscillator options. The major difference is that PIC18F85J90 family devices support a smaller number of primary (external) oscillator options, namely HS and EC Oscillator modes.

While both device families have an internal PLL that can be used with the primary oscillators, the PLL for the PIC18F85J90 family is not enabled as a device configuration option. Instead, it must be enabled in software.

The clocking differences should be considered when making a conversion between the PIC18F8490 and PIC18F85J90 device families.

B.3 LCD Module

When converting an LCD application between the PIC18F85J90 and the PIC18F8490 families, the following things must be considered:

- **Available Segments:** The module for PIC18F85J90 devices supports 33 segments, as opposed to 32 segments in PIC18F8490 devices. (The 80-pin devices of both families support 48 segments. All devices support 4 commons.)
- **Bias Generation:** The PIC18F85J90 version of the module also incorporates its own independent voltage regulator, which supports 4 circuit configurations for bias generation, voltage boost to support displays that operate above device VDD and software contrast control.

- **Additional LCD Function Pins:** The PIC18F85J90 family of devices adds 3 additional LCD function pins in comparison to the PIC18F8490 family. The additional pins are associated with LCD bias generation:
 - LCDBIAS0 (RG0)
 - VLCAP1 (RG2)
 - VLCPA2 (RG3)
- **Segment Assignments:** Eight of the LCD segment functions have been relocated to different I/O pins than in PIC18F8490 devices. These segments are listed in Table B-2.
- **Other Considerations:** In all LCD applications, the connections of PIC18F85J90 devices to external components for LCD bias generation are different than PIC18F8490 devices. The addition of the LCDBIAS0 output requires that this pin be included in bias component configurations. A more complete discussion is provided in **Section 15.3 “LCD Bias Generation”**. The simultaneous use of the external Timer1 oscillator and Segment 32 is not allowed in PIC18F85J90 devices, since these functions are shared on the same pin.

TABLE B-2: ASSIGNMENTS OF MOVED LCD SEGMENTS

LCD Segment	PIC18F8490	PIC18F85J90
SEG16	RA2	RC4
SEG17	RA3	RC3
SEG18	RF0	RA1
SEG27	RG3	RC6
SEG28	RG2	RC7
SEG29	RG0	RB5
SEG30	RG0	RB0
SEG32	RJ0	RC1

Note: Refer to the pinout diagrams for pin locations of I/O ports.

B.4 Pin Differences

Besides the LCD pinout differences already described, there are other differences in the pinouts between the PIC18F85J90 and the PIC18F8490 families:

- Input voltage tolerance
- Output current capabilities
- Available I/O

Pins on the PIC18F85J90 that have digital only input capability will tolerate voltages up to 5.5V, and are thus, tolerant to voltages above V_{DD} . Table 9-1 in **Section 9.1 “I/O Port Pin Capabilities”** contains the complete list.

In addition to input differences, there are output differences as well. PIC18F85J90 devices have three classes of pin output current capability: high, medium and low. Not all I/O pins can source or sink equal levels of current. Only PORTB and PORTC support the 25 mA source/sink capability that is supported by all output pins on the PIC18F8490. Table 9-1 in **Section 9.1 “I/O Port Pin Capabilities”** contains the complete list of output capabilities.

Finally, the pins associated with the CCP, EUSART/AUSART and SPI peripherals can be configured by the user as open-drain outputs. This allows for simpler interfacing with external devices operating at higher voltages. This capability is not directly equivalent to any feature on the PIC18F8490 family.

There are also differences in the implementation of some ports on PIC18F85J90 devices. While the total number of general purpose I/O pins are very similar (67 vs. 66), the implementation of individual pins has notable differences:

- The \overline{MCLR} pin is dedicated only to \overline{MCLR} and cannot be configured as an input (RG5) as it can on PIC18F8490 devices.
- RF0 does not exist on PIC18F85J90 devices.
- RE0, RE1 and RE3 are implemented on PIC18F85J90 devices, but not PIC18F8490 devices.

All of these pin differences (including power pin differences) should be accounted for when making a conversion between PIC18F8490 and PIC18F85J90 devices.

B.5 Other Peripherals

Peripherals must also be considered when making a conversion between the PIC18F85J90 and the PIC18F8490 families:

- **A/D Converter:** The converter for PIC18F85J90 devices require a calibration step prior to normal operation.
- **Data EEPROM:** PIC18F85J90 devices do not have this module but offer self-programming capability.
- **BOR:** PIC18F85J90 devices do not have a programmable BOR. Simple brown-out capability is provided through the use of the internal voltage regulator.
- **LVD:** PIC18F85J90 devices do not have this module. A limited, fixed setpoint capability is provided through the use of the internal voltage regulator.

PIC18F85J90 FAMILY

NOTES:

PIC18F85J90 FAMILY

INDEX

A

A/D	263
A/D Converter Interrupt, Configuring	267
Acquisition Requirements	268
ADCAL Bit	271
ADCON0 Register	263
ADCON1 Register	263
ADCON2 Register	263
ADRESH Register	263, 266
ADRESL Register	263
Analog Port Pins, Configuring	269
Associated Registers	271
Automatic Acquisition Time	269
Calibration	271
Configuring the Module	267
Conversion Clock (TAD)	269
Conversion Requirements	385
Conversion Status (GO/DONE Bit)	266
Conversions	270
Converter Characteristics	384
Operation in Power-Managed Modes	271
Special Event Trigger (CCP)	270
Use of the CCP2 Trigger	270
Absolute Maximum Ratings	349
AC (Timing) Characteristics	366
Load Conditions for Device Timing Specifications	367
Parameter Symbolology	366
Temperature and Voltage Specifications	367
Timing Conditions	367
ACKSTAT	219
ACKSTAT Status Flag	219
ADCAL Bit	271
ADCON0 Register	263
GO/DONE Bit	266
ADCON1 Register	263
ADCON2 Register	263
ADDFSR	338
ADDLW	301
Addressable Universal Synchronous Asynchronous Receiver Transmitter (AUSART). <i>See</i> AUSART.	
ADDULNK	338
ADDWF	301
ADDWFC	302
ADRESH Register	263
ADRESL Register	263, 266
Analog-to-Digital Converter. <i>See</i> A/D.	
ANDLW	302
ANDWF	303
Assembler	
MPASM Assembler	346

AUSART

Asynchronous Mode	254
Associated Registers, Receive	257
Associated Registers, Transmit	255
Receiver	256
Setting up 9-Bit Mode with Address Detect	256
Transmitter	254
Baud Rate Generator (BRG)	252
Associated Registers	252
Baud Rate Error, Calculating	252
Baud Rates, Asynchronous Modes	253
High Baud Rate Select (BRGH Bit)	252
Operation in Power-Managed Modes	252
Sampling	252
Synchronous Master Mode	258
Associated Registers, Receive	260
Associated Registers, Transmit	259
Reception	260
Transmission	258
Synchronous Slave Mode	261
Associated Registers, Receive	262
Associated Registers, Transmit	261
Reception	262
Transmission	261
Auto-Wake-up on Sync Break Character	242

B

Baud Rate Generator	215
BC	303
BCF	304
BF	219
BF Status Flag	219
Bias Generation (LCD)	
Charge Pump Design Considerations	167
Block Diagrams	
A/D	266
Analog Input Model	267
AUSART Receive	256
AUSART Transmit	254
Baud Rate Generator	215
Capture Mode Operation	150
Comparator Analog Input Model	277
Comparator I/O Operating Modes	274
Comparator Output	276
Comparator Voltage Reference	280
Comparator Voltage Reference Output Buffer Example	281
Compare Mode Operation	151
Connections for On-Chip Voltage Regulator	290
Device Clock	29
EUSART Receive	240
EUSART Transmit	238
External Power-on Reset Circuit (Slow VDD Power-up)	47
Fail-Safe Clock Monitor	292
Generic I/O Port Operation	109
Interrupt Logic	94
LCD Clock Generation	162
LCD Driver Module	157
LCD Regulator Connections (M0 and M1)	164
MSSP (I ² C Master Mode)	213
MSSP (I ² C Mode)	194
MSSP (SPI Mode)	185
On-Chip Reset Circuit	45
PIC18F6XJ90	10
PIC18F8XJ90	11

PIC18F85J90 FAMILY

PLL	34	CLRWDT	311
PWM Operation (Simplified)	153	Code Examples	
Reads from Flash Program Memory	85	16 x 16 Signed Multiply Routine	92
Resistor Ladder Configurations for M2	165	16 x 16 Unsigned Multiply Routine	92
Resistor Ladder Configurations for M3	166	8 x 8 Signed Multiply Routine	91
Single Comparator	275	8 x 8 Unsigned Multiply Routine	91
Table Read Operation	81	Changing Between Capture Prescalers	150
Table Write Operation	82	Computed GOTO Using an Offset Value	61
Table Writes to Flash Program Memory	87	Erasing a Flash Program Memory Row	86
Timer0 in 16-Bit Mode	132	Fast Register Stack	61
Timer0 in 8-Bit Mode	132	How to Clear RAM (Bank 1) Using Indirect Addressing	74
Timer1 (16-Bit Read/Write Mode)	136	Implementing a Real-Time Clock Using a Timer1 Interrupt Service	139
Timer1 (8-Bit Mode)	136	Initializing PORTA	110
Timer2	142	Initializing PORTB	112
Timer3 (16-Bit Read/Write Mode)	144	Initializing PORTC	115
Timer3 (8-Bit Mode)	144	Initializing PORTD	118
Watchdog Timer	289	Initializing PORTE	120
BN	304	Initializing PORTF	122
BNC	305	Initializing PORTG	125
BNN	305	Initializing PORTH	127
BNOV	306	Initializing PORTJ	129
BNZ	306	Loading the SSPBUF (SSPSR) Register	188
BOR. <i>See</i> Brown-out Reset.		Reading a Flash Program Memory Word	85
BOV	309	Saving STATUS, WREG and BSR Registers in RAM	108
BRA	307	Writing to Flash Program Memory	88
Break Character (12-Bit) Transmit and Receive	243	Code Protection	283
BRG. <i>See</i> Baud Rate Generator.		COMF	312
BRGH Bit		Comparator	273
TXSTA1 Register	233	Analog Input Connection Considerations	277
TXSTA2 Register	252	Associated Registers	277
Brown-out Reset (BOR)	47	Configuration	274
and On-Chip Voltage Regulator	291	Effects of a Reset	276
Detecting	47	Interrupts	276
BSF	307	Operation	275
BTFSC	308	Operation During Sleep	276
BTFSS	308	Outputs	275
BTG	309	Reference	275
BZ	310	External Signal	275
C		Internal Signal	275
C Compilers		Response Time	275
MPLAB C18	346	Comparator Specifications	364
MPLAB C30	346	Comparator Voltage Reference	279
Calibration (A/D Converter)	271	Accuracy and Error	280
CALL	310	Associated Registers	281
CALLW	339	Configuring	279
Capture (CCP Module)	150	Connection Considerations	280
Associated Registers	152	Effects of a Reset	280
CCP Pin Configuration	150	Operation During Sleep	280
CCPR2H:CCPR2L Registers	150	Compare (CCP Module)	151
Software Interrupt	150	Associated Registers	152
Timer1/Timer3 Mode Selection	150	CCP Pin Configuration	151
Capture/Compare/PWM (CCP)	147	CCPR2 Register	151
Capture Mode. <i>See</i> Capture.		Software Interrupt	151
CCP Mode and Timer Resources	148	Special Event Trigger	145, 151, 270
CCPRxH Register	148	Timer1/Timer3 Mode Selection	151
CCPRxL Register	148	Computed GOTO	61
Compare Mode. <i>See</i> Compare.		Configuration Bits	283
Configuration	148	Configuration Register Protection	294
Interaction of CCP1 and CCP2 for Timer Resources	149		
Interconnect Configurations	148		
Clock Sources	31		
Default System Clock on Reset	32		
Selection Using OSCCON Register	32		
CLRF	311		

PIC18F85J90 FAMILY

Core Features		
Easy Migration	7	
Extended Instruction Set	7	
Memory Options	7	
nanoWatt Technology	7	
Oscillator Options and Features	7	
CPFSEQ	312	
CPFSGT	313	
CPFSLT	313	
Crystal Oscillator/Ceramic Resonator	33	
Customer Change Notification Service	407	
Customer Notification Service	407	
Customer Support	407	
D		
Data Addressing Modes	74	
Comparing Addressing Modes with the Extended Instruction Set Enabled	78	
Direct	74	
Indexed Literal Offset	77	
BSR	79	
Instructions Affected	77	
Mapping Access Bank	79	
Indirect	74	
Inherent and Literal	74	
Data Memory	64	
Access Bank	67	
Bank Select Register (BSR)	64	
Extended Instruction Set	77	
General Purpose Registers	67	
Memory Maps		
PIC18FX3J90/X4J90 Devices	65	
PIC18FX5J90 Devices	66	
Special Function Registers	68	
Special Function Registers	68	
DAW	314	
DC and AC Characteristics		
Graphs and Tables	387	
DC Characteristics	361	
Power-Down and Supply Current	352	
Supply Voltage	351	
DCFSNZ	315	
DECFSZ	314	
Default System Clock	32	
Details on Individual Family Members	8	
Development Support	345	
Device Overview	7	
Features (64-Pin Devices)	9	
Features (80-Pin Devices)	9	
Direct Addressing	75	
E		
Effect on Standard PIC18 Instructions	342	
Effects of Power-Managed Modes on Various Clock Sources	36	
Electrical Characteristics	349	
Enhanced Universal Synchronous Asynchronous Receiver Transmitter (EUSART). See EUSART.		
ENVREG Pin	290	
Equations		
A/D Acquisition Time	268	
A/D Minimum Charging Time	268	
Calculating the Minimum Required Acquisition Time	268	
LCD Static and Dynamic Current	167	
Errata	5	
EUSART		
Asynchronous Mode	238	
12-Bit Break Transmit and Receive	243	
Associated Registers, Receive	241	
Associated Registers, Transmit	239	
Auto-Wake-up on Sync Break	242	
Receiver	240	
Setting up 9-Bit Mode with Address Detect	240	
Transmitter	238	
Baud Rate Generator (BRG)	233	
Associated Registers	233	
Auto-Baud Rate Detect	236	
Baud Rate Error, Calculating	233	
Baud Rates, Asynchronous Modes	234	
High Baud Rate Select (BRGH Bit)	233	
Operation in Power-Managed Modes	233	
Sampling	233	
Synchronous Master Mode	244	
Associated Registers, Receive	246	
Associated Registers, Transmit	245	
Reception	246	
Transmission	244	
Synchronous Slave Mode	247	
Associated Registers, Receive	248	
Associated Registers, Transmit	247	
Reception	248	
Transmission	247	
Extended Instruction Set		
ADDFSR	338	
ADDLW	338	
CALLW	339	
MOVWF	339	
MOVSS	340	
PUSHL	340	
SUBFSR	341	
SUBLW	341	
External Oscillator Modes	33	
EC Modes	34	
HS Modes	33	
F		
Fail-Safe Clock Monitor	283, 292	
Exiting Fail-Safe Operation	293	
Interrupts in Power-Managed Modes	293	
POR or Wake-up from Sleep	293	
WDT During Oscillator Failure	292	
Fast Register Stack	61	
Firmware Instructions	295	
Flash Configuration Words	283	
Flash Program Memory	81	
Associated Registers	89	
Control Registers	82	
EECON1 and EECON2	82	
TABLAT (Table Latch) Register	84	
TBLPTR (Table Pointer) Register	84	
Erase Sequence	86	
Erasing	86	
Operation During Code-Protect	89	
Reading	85	
Table Pointer		
Boundaries Based on Operation	84	
Table Pointer Boundaries	84	
Table Reads and Table Writes	81	
Write Sequence	87	
Writing	87	

PIC18F85J90 FAMILY

Unexpected Termination	89	INFSNZ	317
Write Verify	89	Initialization Conditions for all Registers	51–53
FSCM. See Fail-Safe Clock Monitor.		Instruction Cycle	62
G		Clocking Scheme	62
GOTO	316	Flow/Pipelining	62
H		Instruction Set	295
Hardware Multiplier	91	ADDLW	301
Introduction	91	ADDWF	301
Operation	91	ADDWF (Indexed Literal Offset Mode)	343
Performance Comparison	91	ADDWFC	302
I		ANDLW	302
I/O Ports	109	ANDWF	303
Input Voltage Considerations	109	BC	303
Open-Drain Outputs	110	BCF	304
Output Pin Drive	109	BN	304
Pin Capabilities	109	BNC	305
Pull-up Configuration	110	BNN	305
I ² C Mode (MSSP)	194	BNOV	306
Acknowledge Sequence Timing	222	BNZ	306
Associated Registers	228	BOV	309
Baud Rate Generator	215	BRA	307
Bus Collision		BSF	307
During a Repeated Start Condition	226	BSF (Indexed Literal Offset Mode)	343
During a Stop Condition	227	BTFSC	308
Clock Arbitration	216	BTFSS	308
Clock Stretching	208	BTG	309
10-Bit Slave Receive Mode (SEN = 1)	208	BZ	310
10-Bit Slave Transmit Mode	208	CALL	310
7-Bit Slave Receive Mode (SEN = 1)	208	CLRF	311
7-Bit Slave Transmit Mode	208	CLRWDT	311
Clock Synchronization and the CKP Bit	209	COMF	312
Effects of a Reset	223	CPFSEQ	312
General Call Address Support	212	CPFSGT	313
I ² C Clock Rate w/BRG	215	CPFSLT	313
Master Mode	213	DAW	314
Baud Rate Generator	215	DCFSNZ	315
Operation	214	DECf	314
Reception	219	DECFSZ	315
Repeated Start Condition Timing	218	Extended Instructions	337
Start Condition Timing	217	Considerations when Enabling	342
Transmission	219	Syntax	337
Multi-Master Communication, Bus Collision and Arbitra- tion	223	Use with MPLAB IDE Tools	344
Multi-Master Mode	223	General Format	297
Operation	199	GOTO	316
Read/Write Bit Information (R/W Bit)	199, 201	INCF	316
Registers	194	INCFSZ	317
Serial Clock (SCK/SCL)	201	INFSNZ	317
Slave Mode	199	IORLW	318
Addressing	199	IORWF	318
Addressing Masking	200	LFSR	319
Reception	201	MOVf	319
Transmission	201	MOVFF	320
Sleep Operation	223	MOVLB	320
Stop Condition Timing	222	MOVLW	321
INCF	316	MOVWF	321
INCFSZ	317	MULLW	322
In-Circuit Debugger	294	MULWF	322
In-Circuit Serial Programming (ICSP)	283, 294	NEGF	323
Indexed Literal Offset Addressing		NOP	323
and Standard PIC18 Instructions	342	Opcode Field Descriptions	296
Indexed Literal Offset Mode	342	POP	324
Indirect Addressing	75	PUSH	324
		RCALL	325
		RESET	325
		RETFIE	326

PIC18F85J90 FAMILY

RETLW	326	Configuring the Module	182
RETURN	327	Frame Frequency	168
RLCF	327	Interrupts	180
RLNCF	328	LCDCON Register	158
RRCF	328	LCDDATA Register	158
RRNCF	329	LCDPS Register	158
SETF	329	LCDREG Register	158
SETF (Indexed Literal Offset Mode)	343	LCDSE Register	158
SLEEP	330	Multiplex Types	167
Standard Instructions	295	Operation During Sleep	181
SUBFWB	330	Pixel Control	167
SUBLW	331	Segment Enables	167
SUBWF	331	Waveform Generation	168
SUBWFB	332	LCD Driver	8
SWAPF	332	LCDCON Register	158
TBLRD	333	LCDDATA Register	158
TBLWT	334	LCDPS Register	158
TSTFSZ	335	LCDREG Register	158
XORLW	335	LCDSE Register	158
XORWF	336	LFSR	319
INTCON Register		Liquid Crystal Display (LCD) Driver	157
RBIF Bit	112	Low-Voltage Detection	290
INTCON Registers	95	M	
Inter-Integrated Circuit. <i>See</i> I ² C Mode.		Master Clear ($\overline{\text{MCLR}}$)	47
Internal Oscillator Block	35	Master Synchronous Serial Port (MSSP). <i>See</i> MSSP.	
Adjustment	35	Memory Organization	57
INTOSC Frequency Drift	35	Data Memory	64
INTOSC Output Frequency	35	Program Memory	57
OSC1, OSC2 Pin Configuration	35	Memory Programming Requirements	363
Internal RC Oscillator		Microchip Internet Web Site	407
Use with WDT	289	MOVF	319
Internal Voltage Regulator Specifications	364	MOVFF	320
Internet Address	407	MOVLB	320
Interrupt Sources	283	MOVLW	321
A/D Conversion Complete	267	MOVSF	339
Capture Complete (CCP)	150	MOVSS	340
Compare Complete (CCP)	151	MOVWF	321
Interrupt-on-Change (RB7:RB4)	112	MPLAB ASM30 Assembler, Linker, Librarian	346
TMR0 Overflow	133	MPLAB ICD 2 In-Circuit Debugger	347
TMR1 Overflow	135	MPLAB ICE 2000 High-Performance Universal In-Circuit Emulator	347
TMR2 to PR2 Match (PWM)	153	MPLAB Integrated Development Environment Software	345
TMR3 Overflow	143, 145	MPLAB PM3 Device Programmer	347
Interrupts	93	MPLAB REAL ICE In-Circuit Emulator System	347
During, Context Saving	108	MPLINK Object Linker/MPLIB Object Librarian	346
INTx Pin	108	MSSP	
PORTB, Interrupt-on-Change	108	ACK Pulse	199, 201
TMR0	108	Control Registers (general)	185
Interrupts, Flag Bits		Module Overview	185
Interrupt-on-Change (RB7:RB4) Flag (RBIF Bit)	112	SPI Master/Slave Connection	189
INTOSC, INTRC. <i>See</i> Internal Oscillator Block.		SSPBUF Register	190
IORLW	318	SSPSR Register	190
IORWF	318	MULLW	322
IPR Registers	104	MULWF	322
L		N	
LCD		NEGf	323
Associated Registers	183	NOP	323
Bias Generation	163	Notable Differences Between PIC18F8490 and PIC18F85J90	
Bias Configurations	164	Families	393
M0 and M1	164	LCD Module	394
M2	165	Oscillator Options	394
M3	166	Other Peripherals	395
Bias Types	163	Pin Differences	395
LCD Voltage Regulator	163	Power Requirements	394
Charge Pump	164, 167		
Clock Source Selection	162		

PIC18F85J90 FAMILY

O

Oscillator Configuration	29
EC	29
ECPLL	29
HS	29
HSPLL	29
Internal Oscillator Block	35
INTOSC	29
INTRC	29
Oscillator Selection	283
Oscillator Start-up Timer (OST)	36
Oscillator Switching	31
Oscillator Transitions	32
Oscillator, Timer1	135, 145
Oscillator, Timer3	143

P

Packaging	389
Details	390
Marking	389
PICSTART Plus Development Programmer	348
PIE Registers	101
Pin Functions	
AVDD	27
AVDD	18
AVss	27
AVss	18
ENVREG	18, 27
LCDBIAS3	16, 23
MCLR	12, 19
OSC1/CLKI/RA7	12, 19
OSC2/CLKO/RA6	12, 19
RA0/AN0	12, 19
RA1/AN1/SEG18	12, 19
RA2/AN2/VREF-	12, 19
RA3/AN3/VREF+	12, 19
RA4/T0CKI/SEG14	12, 19
RA5/AN4/SEG15	12, 19
RB0/INT0/SEG30	13, 20
RB1/INT1/SEG8	13, 20
RB2/INT2/SEG9	13, 20
RB3/INT3/SEG10	13, 20
RB4/KBI0/SEG11	13, 20
RB5/KBI1/SEG29	13, 20
RB6/KBI2/PGC	13, 20
RB7/KBI3/PGD	13, 20
RC0/T1OSO/T13CKI	14, 21
RC1/T1OSI/CCP2/SEG32	14, 21
RC2/CCP1/SEG13	14, 21
RC3/SCK/SCL/SEG17	14, 21
RC4/SDI/SDA/SEG16	14, 21
RC5/SDO/SEG12	14, 21
RC6/TX1/CK1/SEG27	14, 21
RC7/RX1/DT1/SEG28	14, 21
RD0/SEG0	15, 22
RD0/SEG1	15, 22
RD2/SEG2	15, 22
RD3/SEG3	15, 22
RD4/SEG4	15, 22
RD5/SEG5	15, 22
RD6/SEG6	15, 22
RD7/SEG7	15, 22
RE0/LCDBIAS1	16, 23
RE1/LCDBIAS2	16, 23
RE3/COM0	16, 23

RE4/COM1	16, 23
RE5/COM2	16, 23
RE6/COM3	16, 23
RE7/CCP2/SEG31	16, 23
RF1/AN6/C2OUT/SEG19	17, 24
RF2/AN7/C1OUT/SEG20	17, 24
RF3/AN8/SEG21	17, 24
RF4/AN9/SEG22	17, 24
RF5/AN10/CVREF/SEG23	17, 24
RF6/AN11/SEG24	17, 24
RF7/AN5/SS/SEG25	17, 24
RG0/LCDBIAS0	18, 25
RG1/TX2/CK2	18, 25
RG2/RX2/DT2/VLCAP1	18, 25
RG3/VLCAP2	18, 25
RG4/SEG26	18, 25
RH0/SEG47	26
RH1/SEG46	26
RH2/SEG45	26
RH3/SEG44	26
RH4/SEG40	26
RH5/SEG41	26
RH6/SEG42	26
RH7/SEG43	26
RJ0	27
RJ1/SEG33	27
RJ2/SEG34	27
RJ3/SEG35	27
RJ4/SEG39	27
RJ5/SEG38	27
RJ6/SEG37	27
RJ7/SEG36	27
VDD	27
VDD	18
VDDCORE/VCAP	18, 27
VSS	27
VSS	18
Pinout I/O Descriptions	
PIC18F6XJ90	12
PIC18F8XJ90	19
PIR Registers	98
PLL	34
ECPLL Oscillator Mode	34
HSPLL Oscillator Mode	34
POP	324
POR. <i>See</i> Power-on Reset.	
PORTA	
Associated Registers	111
LATA Register	110
PORTA Register	110
TRISA Register	110
PORTB	
Associated Registers	114
LATB Register	112
PORTB Register	112
RB7:RB4 Interrupt-on-Change Flag (RBIF Bit)	112
TRISB Register	112
PORTC	
Associated Registers	117
LATC Register	115
PORTC Register	115
RC3/SCK/SCL Pin	201
TRISC Register	115

PIC18F85J90 FAMILY

PORTD	Associated Registers	119	Program Memory	Extended Instruction Set	76
	LATD Register	118		Flash Configuration Words	58
	PORTD Register	118		Hard Memory Vectors	58
	TRISD Register	118		Instructions	63
PORTE	Associated Registers	121		Two-Word	63
	LATE Register	120		Interrupt Vector	58
	PORTE Register	120		Look-up Tables	61
	TRISE Register	120		Memory Maps	57
PORTF	Associated Registers	124		Hard Vectors and Configuration Words	58
	LATF Register	122		Reset Vector	58
	PORTF Register	122		Program Verification and Code Protection	294
	TRISF Register	122		Programming, Device Instructions	295
PORTG	Associated Registers	126		Pulse-Width Modulation. <i>See</i> PWM (CCP Module).	
	LATG Register	125		PUSH	324
	PORTG Register	125		PUSH and POP Instructions	60
	TRISG Register	125		PUSHL	340
PORTH	Associated Registers	128		PWM (CCP Module)	
	LATH Register	127		Associated Registers	155
	PORTH Register	127		Duty Cycle	154
	TRISH Register	127		Example Frequencies/Resolutions	154
PORTJ	Associated Registers	130		Period	153
	LATJ Register	129		Setup for PWM Operation	155
	PORTJ Register	129		TMR2 to PR2 Match	153
	TRISJ Register	129	Q		
Power-Managed Modes	Associated Registers	130		Q Clock	154
and SPI Operation	LATJ Register	129			
	PORTJ Register	129		R	
Clock Sources	TRISJ Register	129		RAM. <i>See</i> Data Memory.	
Clock Transitions and Status Indicators	Power-Managed Modes	37		RC_IDLE Mode	43
Entering	and SPI Operation	193		RC_RUN Mode	40
Exiting Idle and Sleep Modes	Clock Sources	37		RCALL	325
By Interrupt	Clock Transitions and Status Indicators	38		RCON Register	
By Reset	Entering	37		Bit Status During Initialization	50
By WDT Time-out	Exiting Idle and Sleep Modes	43		Reader Response	408
Without an Oscillator Start-up Delay	By Interrupt	43		Register File	67
Idle Modes	By Reset	43		Register File Summary	69–72
PRI_IDLE	By WDT Time-out	43		Registers	
RC_IDLE	Without an Oscillator Start-up Delay	43		ADCON0 (A/D Control 0)	263
SEC_IDLE	Idle Modes	41		ADCON1 (A/D Control 1)	264
Multiple Sleep Commands	PRI_IDLE	42		ADCON2 (A/D Control 2)	265
Run Modes	RC_IDLE	43		BAUDCON1 (Baud Rate Control 1)	232
PRI_RUN	SEC_IDLE	42		CCPxCON (CCPx Control)	147
RC_RUN	Multiple Sleep Commands	38		CMCON (Comparator Control)	273
SEC_RUN	Run Modes	38		CONFIG1H (Configuration 1 High)	285
Selecting	PRI_RUN	38		CONFIG1L (Configuration 1 Low)	285
Sleep Mode	RC_RUN	40		CONFIG2H (Configuration 2 High)	287
Summary (table)	SEC_RUN	38		CONFIG2L (Configuration 2 Low)	286
Power-on Reset (POR)	Selecting	37		CONFIG3H (Configuration 3 High)	287
Power-up Delays	Sleep Mode	41		CVRCON (Comparator Voltage Reference Control)	279
Power-up Timer (PWRT)	Summary (table)	37		DEVID1 (Device ID Register 1)	288
Time-out Sequence	Power-on Reset (POR)	47		DEVID2 (Device ID Register 2)	288
Prescaler, Capture	Power-up Delays	36		EECON1 (EEPROM Control 1)	83
Prescaler, Timer0	Power-up Timer (PWRT)	36, 48		INTCON (Interrupt Control)	95
Prescaler, Timer2	Time-out Sequence	48		INTCON2 (Interrupt Control 2)	96
PRI_IDLE Mode	Prescaler, Capture	150		INTCON3 (Interrupt Control 3)	97
PRI_RUN Mode	Prescaler, Timer0	133		IPR1 (Peripheral Interrupt Priority 1)	104
Program Counter	Prescaler, Timer2	154		IPR2 (Peripheral Interrupt Priority 2)	105
PCL, PCH and PCU Registers	PRI_IDLE Mode	42		IPR3 (Peripheral Interrupt Priority 3)	106
PCLATH and PCLATU Registers	PRI_RUN Mode	38		LCDCON (LCD Control)	158
	Program Counter	59		LCDDATAx (LCD Data)	161
				LCDPS (LCD Phase)	159
				LCDREG (LCD Voltage Regulator Control)	163
				LCDSEx (LCD Segment Enable)	160
				OSSCON (Oscillator Control)	30

PIC18F85J90 FAMILY

OSCTUNE (Oscillator Tuning)	31
PIE1 (Peripheral Interrupt Enable 1)	101
PIE2 (Peripheral Interrupt Enable 2)	102
PIE3 (Peripheral Interrupt Enable 3)	103
PIR1 (Peripheral Interrupt Request (Flag) 1)	98
PIR2 (Peripheral Interrupt Request (Flag) 2)	99
PIR3 (Peripheral Interrupt Request (Flag) 3)	100
RCON (Reset Control)	46, 107
RCSTA1 (EUSART Receive Status and Control)	231
RCSTA2 (AUSART Receive Status and Control)	251
SSPCON1 (MSSP Control 1, I ² C Mode)	196
SSPCON1 (MSSP Control 1, SPI Mode)	187
SSPCON2 (MSSP Control 2, I ² C Master Mode)	197
SSPCON2 (MSSP Control 2, I ² C Slave Mode)	198
SSPSTAT (MSSP Status, I ² C Mode)	195
SSPSTAT (MSSP Status, SPI Mode)	186
STATUS	73
STKPTR (Stack Pointer)	60
T0CON (Timer0 Control)	131
T1CON (Timer1 Control)	135
T2CON (Timer2 Control)	141
T3CON (Timer3 Control)	143
TXSTA1 (EUSART Transmit Status and Control)	230
TXSTA2 (AUSART Transmit Status and Control)	250
WDTCON (Watchdog Timer Control)	289
RESET	325
Reset	45
Brown-out Reset (BOR)	45
MCLR Reset, During Power-Managed Modes	45
MCLR Reset, Normal Operation	45
Power-on Reset (POR)	45
RESET Instruction	45
Stack Full Reset	45
Stack Underflow Reset	45
Watchdog Timer (WDT) Reset	45
Resets	283
Brown-out Reset (BOR)	283
Oscillator Start-up Timer (OST)	283
Power-on Reset (POR)	283
Power-up Timer (PWRT)	283
RETFIE	326
RETLW	326
RETURN	327
Return Address Stack	59
Return Stack Pointer (STKPTR)	60
RLCF	327
RLNCF	328
RRCF	328
RRNCF	329
S	
SCK	185
SDI	185
SDO	185
SEC_IDLE Mode	42
SEC_RUN Mode	38
Serial Clock, SCK	185
Serial Data In (SDI)	185
Serial Data Out (SDO)	185
Serial Peripheral Interface. <i>See</i> SPI Mode.	
SETF	329
Slave Select (SS)	185
SLEEP	330
Sleep	
OSC1 and OSC2 Pin States	36
Software Simulator (MPLAB SIM)	346
Special Event Trigger. <i>See</i> Compare (CCP Module).	
Special Features of the CPU	283
SPI Mode (MSSP)	
Associated Registers	193
Bus Mode Compatibility	193
Effects of a Reset	193
Enabling SPI I/O	189
Master Mode	190
Master/Slave Connection	189
Operation	188
Operation in Power-Managed Modes	193
Serial Clock	185
Serial Data In	185
Serial Data Out	185
Slave Mode	191
Slave Select	185
Slave Select Synchronization	191
SPI Clock	190
Typical Connection	189
SS	185
SSPOV	219
SSPOV Status Flag	219
SSPSTAT Register	
R/W Bit	199, 201
Stack Full/Underflow Resets	61
SUBFSR	341
SUBFWB	330
SUBLW	331
SUBULNK	341
SUBWFB	331
SUBWFB	332
SWAPF	332
T	
Table Pointer Operations (table)	84
Table Reads/Table Writes	61
TBLRD	333
TBLWT	334
Timer0	131
Associated Registers	133
Clock Source Select (T0CS Bit)	132
Operation	132
Overflow Interrupt	133
Prescaler	133
Switching Assignment	133
Prescaler Assignment (PSA Bit)	133
Prescaler Select (T0PS2:T0PS0 Bits)	133
Prescaler. <i>See</i> Prescaler, Timer0.	
Reads and Writes in 16-Bit Mode	132
Source Edge Select (T0SE Bit)	132
Timer1	135
16-Bit Read/Write Mode	137
Associated Registers	139
Interrupt	138
Operation	136
Oscillator	135, 137
Layout Considerations	138
Oscillator, as Secondary Clock	31
Overflow Interrupt	135
Resetting, Using the CCP Special Event Trigger	138
TMR1H Register	135
TMR1L Register	135
Use as a Clock Source	137
Use as a Real-Time Clock	138

PIC18F85J90 FAMILY

Timer2	141	I ² C Slave Mode (7-Bit Reception, SEN = 1)	210
Associated Registers	142	I ² C Slave Mode (7-Bit Transmission)	204
Interrupt	142	I ² C Slave Mode General Call Address Sequence (7 or 10-Bit Address Mode)	212
Operation	141	I ² C Stop Condition Receive or Transmit Mode	222
Output	142	LCD Interrupt in Quarter Duty Cycle Drive	180
PR2 Register	153	LCD Sleep Entry/Exit When SLPEN = 1 or CS1:CS0 = 00	181
TMR2 to PR2 Match Interrupt	153	MSSP I ² C Bus Data	381
Timer3	143	MSSP I ² C Bus Start/Stop Bits	381
16-Bit Read/Write Mode	145	PWM Output	153
Associated Registers	145	Repeated Start Condition	218
Operation	144	Reset, Watchdog Timer (WDT), Oscillator Start-up Timer (OST) and Power-up Timer (PWRT)	371
Oscillator	143, 145	Send Break Character Sequence	243
Overflow Interrupt	143, 145	Slave Synchronization	191
Special Event Trigger (CCP)	145	Slow Rise Time (MCLR Tied to VDD, VDD Rise > TPWRT)	49
TMR3H Register	143	SPI Mode (Master Mode)	190
TMR3L Register	143	SPI Mode (Slave Mode, CKE = 0)	192
Timing Diagrams		SPI Mode (Slave Mode, CKE = 1)	192
A/D Conversion	385	Synchronous Reception (Master Mode, SREN)	246, 260
Acknowledge Sequence	222	Synchronous Transmission	244, 258
Asynchronous Reception	241, 257	Synchronous Transmission (Through TXEN) ..	245, 259
Asynchronous Transmission	239, 255	Time-out Sequence on Power-up (MCLR Not Tied to VDD), Case 1	48
Asynchronous Transmission (Back to Back) ..	239, 255	Time-out Sequence on Power-up (MCLR Not Tied to VDD), Case 2	49
Automatic Baud Rate Calculation	237	Time-out Sequence on Power-up (MCLR Tied to VDD, VDD Rise T _{pwrt})	48
Auto-Wake-up Bit (WUE) During Normal Operation	242	Timer0 and Timer1 External Clock	372
Auto-Wake-up Bit (WUE) During Sleep	242	Transition for Entry to Idle Mode	42
Baud Rate Generator with Clock Arbitration	216	Transition for Entry to SEC_RUN Mode	39
BRG Overflow Sequence	237	Transition for Entry to Sleep Mode	41
BRG Reset Due to SDA Arbitration During Start Condi- tion	225	Transition for Two-Speed Start-up (INTRC to HSPLL)	291
Bus Collision During a Repeated Start Condition (Case 1)	226	Transition for Wake From Idle to Run Mode	42
Bus Collision During a Repeated Start Condition (Case 2)	226	Transition for Wake from Sleep (HSPLL)	41
Bus Collision During a Start Condition (SCL = 0) ..	225	Transition From RC_RUN Mode to PRI_RUN Mode .	40
Bus Collision During a Stop Condition (Case 1)	227	Transition From SEC_RUN Mode to PRI_RUN Mode (HSPLL)	39
Bus Collision During a Stop Condition (Case 2)	227	Transition to RC_RUN Mode	40
Bus Collision During Start Condition (SDA Only)	224	Type-A in 1/2 MUX, 1/2 Bias Drive	170
Bus Collision for Transmit and Acknowledge	223	Type-A in 1/2 MUX, 1/3 Bias Drive	172
Capture/Compare/PWM	373	Type-A in 1/3 MUX, 1/2 Bias Drive	174
CLKO and I/O	370	Type-A in 1/3 MUX, 1/3 Bias Drive	176
Clock Synchronization	209	Type-A in 1/4 MUX, 1/3 Bias Drive	178
Clock/Instruction Cycle	62	Type-A/Type-B in Static Drive	169
EUSART/AUSART Synchronous Receive (Master/ Slave)	383	Type-B in 1/2 MUX, 1/2 Bias Drive	171
EUSART/AUSART Synchronous Transmission (Master/ Slave)	383	Type-B in 1/2 MUX, 1/3 Bias Drive	173
Example SPI Master Mode (CKE = 0)	374	Type-B in 1/3 MUX, 1/2 Bias Drive	175
Example SPI Master Mode (CKE = 1)	375	Type-B in 1/3 MUX, 1/3 Bias Drive	177
Example SPI Slave Mode (CKE = 0)	376	Type-B in 1/4 MUX, 1/3 Bias Drive	179
Example SPI Slave Mode (CKE = 1)	377		
External Clock (All Modes Except PLL)	368		
Fail-Safe Clock Monitor	293		
First Start Bit Timing	217		
I ² C Bus Data	379		
I ² C Bus Start/Stop Bits	378		
I ² C Master Mode (7 or 10-Bit Transmission)	220		
I ² C Master Mode (7-Bit Reception)	221		
I ² C Slave Mode (10-Bit Reception, SEN = 0)	205		
I ² C Slave Mode (10-Bit Reception, SEN = 0, ADMSK = 01001)	206		
I ² C Slave Mode (10-Bit Reception, SEN = 1)	211		
I ² C Slave Mode (10-Bit Transmission)	207		
I ² C Slave Mode (7-bit Reception, SEN = 0)	202		
I ² C Slave Mode (7-bit Reception, SEN = 0, ADMSK = 01011)	203		

PIC18F85J90 FAMILY

Timing Diagrams and Specifications

Capture/Compare/PWM Requirements	373
CLKO and I/O Requirements	370
EUSART/AUSART Synchronous Receive Requirements	383
EUSART/AUSART Synchronous Transmission Requirements	383
Example SPI Mode Requirements (Master Mode, CKE = 0)	374
Example SPI Mode Requirements (Master Mode, CKE = 1)	375
Example SPI Mode Requirements (Slave Mode, CKE = 0)	376
Example SPI Slave Mode Requirements (CKE = 1)	377
External Clock Requirements	368
I ² C Bus Data Requirements (Slave Mode)	380
I ² C Bus Start/Stop Bits Requirements (Slave Mode)	378
Internal RC Accuracy	369
MSSP I ² C Bus Data Requirements	382
MSSP I ² C Bus Start/Stop Bits Requirements	381
PLL Clock	369
Reset, Watchdog Timer, Oscillator Start-up Timer, Power-up Timer and Brown-out Reset Requirements ..	371
Timer0 and Timer1 External Clock Requirements ..	372
Top-of-Stack Access	59
TSTFSZ	335
Two-Speed Start-up	283, 291
Two-Word Instructions	
Example Cases	63

V

VDDCORE/VCAP Pin	290
Voltage Reference Specifications	364
Voltage Regulator (On-Chip)	290
Brown-out Reset (BOR)	291
Low-Voltage Detection (LVD)	290
Operation in Sleep Mode	291
Power-up Requirements	291

W

Watchdog Timer (WDT)	283, 289
Associated Registers	289
Control Register	289
During Oscillator Failure	292
Programming Considerations	289
WCOL	217, 218, 219, 222
WCOL Status Flag	217, 218, 219, 222
WWW Address	407
WWW, On-Line Support	5

X

XORLW	335
XORWF	336

THE MICROCHIP WEB SITE

Microchip provides online support via our WWW site at www.microchip.com. This web site is used as a means to make files and information easily available to customers. Accessible by using your favorite Internet browser, the web site contains the following information:

- **Product Support** – Data sheets and errata, application notes and sample programs, design resources, user's guides and hardware support documents, latest software releases and archived software
- **General Technical Support** – Frequently Asked Questions (FAQ), technical support requests, online discussion groups, Microchip consultant program member listing
- **Business of Microchip** – Product selector and ordering guides, latest Microchip press releases, listing of seminars and events, listings of Microchip sales offices, distributors and factory representatives

CUSTOMER CHANGE NOTIFICATION SERVICE

Microchip's customer notification service helps keep customers current on Microchip products. Subscribers will receive e-mail notification whenever there are changes, updates, revisions or errata related to a specified product family or development tool of interest.

To register, access the Microchip web site at www.microchip.com, click on Customer Change Notification and follow the registration instructions.

CUSTOMER SUPPORT

Users of Microchip products can receive assistance through several channels:

- Distributor or Representative
- Local Sales Office
- Field Application Engineer (FAE)
- Technical Support

Customers should contact their distributor, representative or field application engineer (FAE) for support. Local sales offices are also available to help customers. A listing of sales offices and locations is included in the back of this document.

Technical support is available through the web site at: <http://support.microchip.com>

PIC18F85J90 FAMILY

PRODUCT IDENTIFICATION SYSTEM

To order or obtain information, e.g., on pricing or delivery, refer to the factory or the listed sales office.

<u>PART NO.</u>	<u>X</u>	<u>/XX</u>	<u>XXX</u>
Device	Temperature Range	Package	Pattern
Device	PIC18F63J90/64J90/65J90 ⁽¹⁾ , PIC18F83J90/84J90/85J90 ⁽¹⁾ , PIC18F63J90/64J90/65J90T ⁽²⁾ , PIC18F83J90/84J90/85J90T ⁽²⁾		
Temperature Range	I	= -40°C to +85°C (Industrial)	
Package	PT	= TQFP (Thin Quad Flatpack)	
Pattern	QTP, SQTP, Code or Special Requirements (blank otherwise)		

Examples:

a) PIC18F85J90-I/PT_301 = Industrial temp., TQFP package, QTP pattern #301.

b) PIC18F63J90T-I/PT = Tape and reel, Industrial temp., TQFP package.

Note 1: F = Standard Voltage Range
2: T = in tape and reel



WORLDWIDE SALES AND SERVICE

AMERICAS

Corporate Office

2355 West Chandler Blvd.
Chandler, AZ 85224-6199
Tel: 480-792-7200
Fax: 480-792-7277
Technical Support:
<http://support.microchip.com>
Web Address:
www.microchip.com

Atlanta

Duluth, GA
Tel: 678-957-9614
Fax: 678-957-1455

Boston

Westborough, MA
Tel: 774-760-0087
Fax: 774-760-0088

Chicago

Itasca, IL
Tel: 630-285-0071
Fax: 630-285-0075

Dallas

Addison, TX
Tel: 972-818-7423
Fax: 972-818-2924

Detroit

Farmington Hills, MI
Tel: 248-538-2250
Fax: 248-538-2260

Kokomo

Kokomo, IN
Tel: 765-864-8360
Fax: 765-864-8387

Los Angeles

Mission Viejo, CA
Tel: 949-462-9523
Fax: 949-462-9608

Santa Clara

Santa Clara, CA
Tel: 408-961-6444
Fax: 408-961-6445

Toronto

Mississauga, Ontario,
Canada
Tel: 905-673-0699
Fax: 905-673-6509

ASIA/PACIFIC

Asia Pacific Office

Suites 3707-14, 37th Floor
Tower 6, The Gateway
Harbour City, Kowloon
Hong Kong
Tel: 852-2401-1200
Fax: 852-2401-3431

Australia - Sydney

Tel: 61-2-9868-6733
Fax: 61-2-9868-6755

China - Beijing

Tel: 86-10-8528-2100
Fax: 86-10-8528-2104

China - Chengdu

Tel: 86-28-8665-5511
Fax: 86-28-8665-7889

China - Fuzhou

Tel: 86-591-8750-3506
Fax: 86-591-8750-3521

China - Hong Kong SAR

Tel: 852-2401-1200
Fax: 852-2401-3431

China - Qingdao

Tel: 86-532-8502-7355
Fax: 86-532-8502-7205

China - Shanghai

Tel: 86-21-5407-5533
Fax: 86-21-5407-5066

China - Shenyang

Tel: 86-24-2334-2829
Fax: 86-24-2334-2393

China - Shenzhen

Tel: 86-755-8203-2660
Fax: 86-755-8203-1760

China - Shunde

Tel: 86-757-2839-5507
Fax: 86-757-2839-5571

China - Wuhan

Tel: 86-27-5980-5300
Fax: 86-27-5980-5118

China - Xian

Tel: 86-29-8833-7250
Fax: 86-29-8833-7256

ASIA/PACIFIC

India - Bangalore

Tel: 91-80-4182-8400
Fax: 91-80-4182-8422

India - New Delhi

Tel: 91-11-4160-8631
Fax: 91-11-4160-8632

India - Pune

Tel: 91-20-2566-1512
Fax: 91-20-2566-1513

Japan - Yokohama

Tel: 81-45-471-6166
Fax: 81-45-471-6122

Korea - Gumi

Tel: 82-54-473-4301
Fax: 82-54-473-4302

Korea - Seoul

Tel: 82-2-554-7200
Fax: 82-2-558-5932 or
82-2-558-5934

Malaysia - Penang

Tel: 60-4-646-8870
Fax: 60-4-646-5086

Philippines - Manila

Tel: 63-2-634-9065
Fax: 63-2-634-9069

Singapore

Tel: 65-6334-8870
Fax: 65-6334-8850

Taiwan - Hsin Chu

Tel: 886-3-572-9526
Fax: 886-3-572-6459

Taiwan - Kaohsiung

Tel: 886-7-536-4818
Fax: 886-7-536-4803

Taiwan - Taipei

Tel: 886-2-2500-6610
Fax: 886-2-2508-0102

Thailand - Bangkok

Tel: 66-2-694-1351
Fax: 66-2-694-1350

EUROPE

Austria - Wels

Tel: 43-7242-2244-39
Fax: 43-7242-2244-393

Denmark - Copenhagen

Tel: 45-4450-2828
Fax: 45-4485-2829

France - Paris

Tel: 33-1-69-53-63-20
Fax: 33-1-69-30-90-79

Germany - Munich

Tel: 49-89-627-144-0
Fax: 49-89-627-144-44

Italy - Milan

Tel: 39-0331-742611
Fax: 39-0331-466781

Netherlands - Drunen

Tel: 31-416-690399
Fax: 31-416-690340

Spain - Madrid

Tel: 34-91-708-08-90
Fax: 34-91-708-08-91

UK - Wokingham

Tel: 44-118-921-5869
Fax: 44-118-921-5820

12/08/06