

**300kHz SYNCHRONOUS PWM CONTROLLER**

PRODUCTION DATA SHEET

**Pb Free Product**
**DESCRIPTION**

The NX2124/2124A controller IC is a synchronous Buck controller IC designed for step down DC to DC converter applications. It is optimized to convert bus voltages from 2V to 25V to outputs as low as 0.8V voltage. The NX2124/2124A operates at fixed 300kHz, employs fixed loss-less current limiting by sensing the R<sub>ds(on)</sub> of synchronous MOSFET followed by hiccup feature. NX2124A has higher current limit threshold than NX2124. Feedback under voltage also triggers hiccup.

Other features of the device are: 5V gate drive, Adaptive deadband control, Internal digital soft start, V<sub>cc</sub> undervoltage lock out and shutdown capability via the comp pin.

**FEATURES**

- Bus voltage operation from 2V to 25V
- Fixed 300kHz voltage mode controller
- Internal Digital Soft Start Function
- Prebias Startup
- Less than 50 nS adaptive deadband
- Current limit triggers hiccup by sensing R<sub>ds(on)</sub> of Synchronous MOSFET
- No negative spike at V<sub>out</sub> during startup and shutdown
- Pb-free and RoHS compliant

**APPLICATIONS**

- Graphic Card on board converters
- Memory V<sub>ddq</sub> Supply in mother board applications
- On board DC to DC such as 5V to 3.3V, 2.5V or 1.8V
- Hard Disk Drive
- Set Top Box

**TYPICAL APPLICATION**

Figure1 - Typical application of 2124

**ORDERING INFORMATION**

Device	Temperature	Package	Frequency	OCP Threshold	Pb-Free
NX2124CSTR	0 to 70 °C	SOIC-8L	300kHz	360mV	Yes
NX2124ACSTR	0 to 70 °C	SOIC-8L	300kHz	540mV	Yes

**ABSOLUTE MAXIMUM RATINGS**(NOTE1)

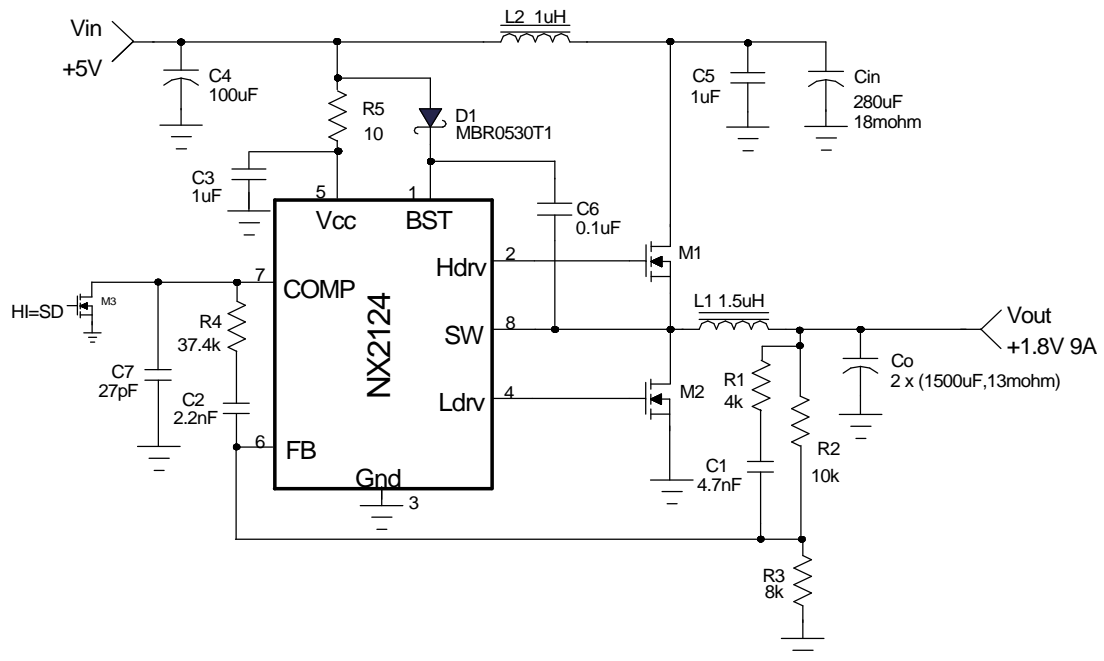
Vcc to GND & BST to SW voltage .....	6.5V
BST to GND Voltage .....	40V
SW to GND Voltage .....	-3V to 35V
Storage Temperature Range .....	-65°C to 150°C
Operating Junction Temperature Range .....	-40°C to 125°C

NOTE1: Stresses above those listed in "ABSOLUTE MAXIMUM RATINGS", may cause permanent damage to the device. This is a stress only rating and operation of the device at these or any other conditions above those indicated in the operational sections of this specification is not implied.

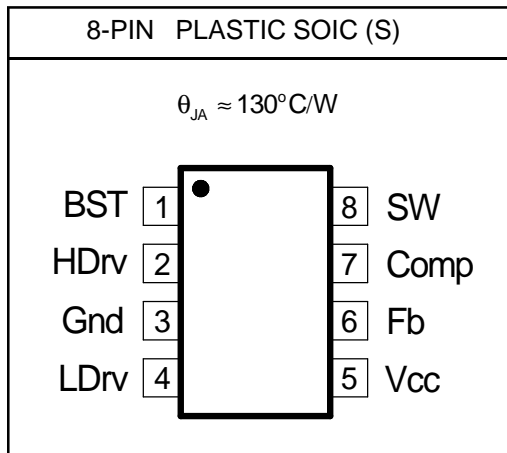
**PACKAGE INFORMATION**

**ELECTRICAL SPECIFICATIONS**

Unless otherwise specified, these specifications apply over Vcc = 5V, and T<sub>A</sub> = 0 to 70°C. Typical values refer to T<sub>A</sub> = 25°C. Low duty cycle pulse testing is used which keeps junction and case temperatures equal to the ambient temperature.

PARAMETER	SYM	Test Condition	Min	TYP	MAX	Units
<b>Reference Voltage</b>						
Ref Voltage	V <sub>REF</sub>	4.5V < Vcc < 5.5V		0.8		V
Ref Voltage line regulation				0.4		%
<b>Supply Voltage(Vcc)</b>						
V <sub>CC</sub> Voltage Range	V <sub>CC</sub>		4.5	5	5.5	V
V <sub>CC</sub> Supply Current (Static)	I <sub>CC</sub> (Static)	Outputs not switching		3		mA
V <sub>CC</sub> Supply Current (Dynamic)	I <sub>CC</sub> (Dynamic)	C <sub>LOAD</sub> =3300pF F <sub>S</sub> =300kHz		5		mA
<b>Supply Voltage(V<sub>BST</sub>)</b>						
V <sub>BST</sub> Supply Current (Static)	I <sub>BST</sub> (Static)	Outputs not switching		0.15		mA
V <sub>BST</sub> Supply Current (Dynamic)	I <sub>BST</sub> (Dynamic)	C <sub>LOAD</sub> =3300pF F <sub>S</sub> =300kHz		5		mA
<b>Under Voltage Lockout</b>						
V <sub>CC</sub> -Threshold	V <sub>CC_UVLO</sub>	V <sub>CC</sub> Rising		4.2		V
V <sub>CC</sub> -Hysteresis	V <sub>CC_Hyst</sub>	V <sub>CC</sub> Falling		0.22		V

PARAMETER	SYM	Test Condition	Min	TYP	MAX	Units
<b>SS</b>						
Soft Start time	T <sub>SS</sub>	F <sub>sw</sub> =300Khz		3.4		mS
<b>Oscillator (Rt)</b>				1.7		
Frequency	F <sub>S</sub>	NX2124, NX2124A		300		kHz
Ramp-Amplitude Voltage	V <sub>RAMP</sub>			1.6		V
Max Duty Cycle				84		%
Min Duty Cycle					0	%
<b>Error Amplifiers</b>						
Transconductance				2000		umho
Input Bias Current	I <sub>b</sub>			10		nA
Comp SD Threshold				0.3		V
<b>FBUVLO</b>						
Feedback UVLO threshold		percent of nominal	65	70	75	%
<b>High Side Driver(C<sub>L</sub>=2200pF)</b>						
Output Impedance , Sourcing	R <sub>source</sub> (Hdrv)	I=200mA		1.9		ohm
Output Impedance , Sinking	R <sub>sink</sub> (Hdrv)	I=200mA		1.7		ohm
Sourcing Current	I <sub>source</sub> (Hdrv)			1		A
Sinking Current	I <sub>sink</sub> (Hdrv)			1.2		A
Rise Time	T <sub>Hdrv</sub> (Rise)			14		ns
Fall Time	T <sub>Hdrv</sub> (Fall)			17		ns
Deadband Time	T <sub>dead</sub> (L to H)	Ldrv going Low to Hdrv going High, 10%-10%		30		ns
<b>Low Side Driver (C<sub>L</sub>=2200pF)</b>						
Output Impedance, Sourcing Current	R <sub>source</sub> (Ldrv)	I=200mA		1.9		ohm
Output Impedance, Sinking Current	R <sub>sink</sub> (Ldrv)	I=200mA		1		ohm
Sourcing Current	I <sub>source</sub> (Ldrv)			1		A
Sinking Current	I <sub>sink</sub> (Ldrv)			2		A
Rise Time	T <sub>Ldrv</sub> (Rise)			13		ns
Fall Time	T <sub>Ldrv</sub> (Fall)			12		ns
Deadband Time	T <sub>dead</sub> (H to L)	SW going Low to Ldrv going High, 10% to 10%		10		ns
<b>OCP</b>						
OCP voltage		NX2124		360		mV
		NX2124A		540		

**PIN DESCRIPTIONS**

<b>PIN #</b>	<b>PIN SYMBOL</b>	<b>PIN DESCRIPTION</b>
1	BST	This pin supplies voltage to the high side driver. A high frequency ceramic capacitor of 0.1 to 1 uF must be connected from this pin to SW pin.
2	HDRV	High side MOSFET gate driver.
3	GND	Ground pin.
4	LDRV	Low side MOSFET gate driver. For the high current application, a 4.7nF capacitor is recommended to be placed on low side MOSFET's gate to ground. This is to prevent undesired Cdv/dt induced low side MOSFET's turn on to happen, which is caused by fast voltage change on the drain of low side MOSFET in synchronous buck converter and lower the system efficiency.
5	Vcc	Voltage supply for the internal circuit as well as the low side MOSFET gate driver. A 1uF high frequency ceramic capacitor must be connected from this pin to GND pin.
6	FB	This pin is the error amplifier inverting input. This pin is also connected to the output UVLO comparator. When this pin falls below 0.56V, both HDRV and LDRV outputs are in hiccup.
7	COMP	This pin is the output of the error amplifier and together with FB pin is used to compensate the voltage control feedback loop. This pin is also used as a shut down pin. When this pin is pulled below 0.3V, both drivers are turned off and internal soft start is reset.
8	SW	This pin is connected to the source of the high side MOSFET and provides return path for the high side driver. Also SW senses the low side MOSFETS current, when the pin voltage is lower than 360mV for NX2124, 540mV for NX2124A, hiccup will be triggered.

**BLOCK DIAGRAM**

Figure 2 - Simplified block diagram of the NX2124/NX2124A

## APPLICATION INFORMATION

### Symbol Used In Application Information:

$V_{IN}$	- Input voltage
$V_{OUT}$	- Output voltage
$I_{OUT}$	- Output current
$\Delta V_{RIPPLE}$	- Output voltage ripple
$F_S$	- Working frequency
$\Delta I_{RIPPLE}$	- Inductor current ripple

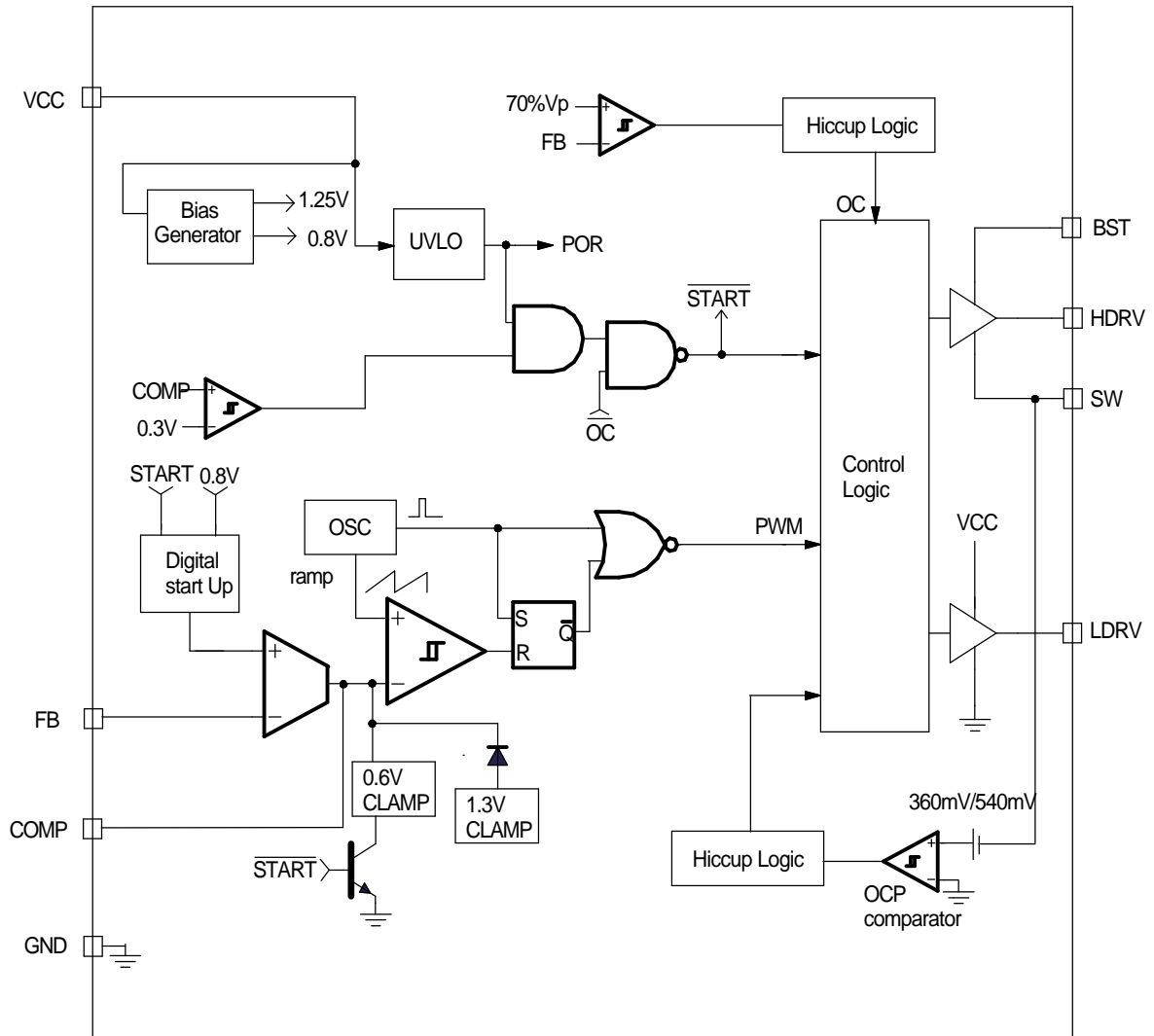
### Design Example

The following is typical application for NX2124, the schematic is figure 1.

$V_{IN} = 5V$
$V_{OUT} = 1.8V$
$F_S = 300kHz$
$I_{OUT} = 9A$
$\Delta V_{RIPPLE} \leq 20mV$
$\Delta V_{DROOP} \leq 100mV @ 9A \text{ step}$

### Output Inductor Selection

The selection of inductor value is based on inductor ripple current, power rating, working frequency and efficiency. Larger inductor value normally means smaller ripple current. However if the inductance is chosen too large, it brings slow response and lower efficiency. Usually the ripple current ranges from 20% to 40% of the output current. This is a design freedom which can be decided by design engineer according to various application requirements. The inductor value can be calculated by using the following equations:

$$L_{OUT} = \frac{V_{IN} - V_{OUT}}{\Delta I_{RIPPLE}} \times \frac{V_{OUT}}{V_{IN}} \times \frac{1}{F_S} \quad \dots(1)$$

$$I_{RIPPLE} = k \times I_{OUTPUT}$$

where k is between 0.2 to 0.4.  
Select k=0.3, then

$$L_{OUT} = \frac{5V - 1.8V}{0.3 \times 9A} \times \frac{1.8V}{5V} \times \frac{1}{300kHz}$$

$$L_{OUT} = 1.4\mu H$$

Choose inductor from COILCRAFT DO5010P-152HC with L=1.5uH is a good choice.

Current Ripple is recalculated as

$$\Delta I_{RIPPLE} = \frac{V_{IN} - V_{OUT}}{L_{OUT}} \times \frac{V_{OUT}}{V_{IN}} \times \frac{1}{F_S}$$

$$= \frac{5V - 1.8V}{1.5\mu H} \times \frac{1.8V}{5V} \times \frac{1}{300kHz} = 2.56A \quad \dots(2)$$

### Output Capacitor Selection

Output capacitor is basically decided by the amount of the output voltage ripple allowed during steady state(DC) load condition as well as specification for the load transient. The optimum design may require a couple of iterations to satisfy both condition.

#### Based on DC Load Condition

The amount of voltage ripple during the DC load condition is determined by equation(3).

$$\Delta V_{RIPPLE} = ESR \times \Delta I_{RIPPLE} + \frac{\Delta I_{RIPPLE}}{8 \times F_S \times C_{OUT}} \quad \dots(3)$$

Where ESR is the output capacitors' equivalent series resistance,  $C_{OUT}$  is the value of output capacitors.

Typically when large value capacitors are selected such as Aluminum Electrolytic, POSCAP and OSCON types are used, the amount of the output voltage ripple is dominated by the first term in equation(3) and the second term can be neglected.

For this example, electrolytic capacitors are chosen as output capacitors, the ESR and inductor current typically determines the output voltage ripple.

$$ESR_{desire} = \frac{\Delta V_{RIPPLE}}{\Delta I_{RIPPLE}} = \frac{20mV}{2.56A} = 7.8m\Omega \quad \dots(4)$$

If low ESR is required, for most applications, multiple capacitors in parallel are better than a big capacitor. For example, SANYO electrolytic capacitor 16ME1500WG is chosen.

$$N = \frac{ESR_E \times \Delta I_{RIPPLE}}{\Delta V_{RIPPLE}} \quad \dots(5)$$

Number of Capacitor is calculated as

$$N = \frac{13m\Omega \times 2.56A}{20mV}$$

$$N = 1.7$$

The number of capacitor has to be round up to a integer. Choose N =2.

If ceramic capacitors are chosen as output ca

capacitors, both terms in equation (3) need to be evaluated to determine the overall ripple. Usually when this type of capacitors are selected, the amount of capacitance per single unit is not sufficient to meet the transient specification, which results in parallel configuration of multiple capacitors .

For example, one 100uF, X5R ceramic capacitor with 2mΩ ESR is used. The amount of output ripple is

$$\Delta V_{\text{RIPPLE}} = 2\text{m}\Omega \times 2.56\text{A} + \frac{2.56\text{A}}{8 \times 300\text{kHz} \times 100\mu\text{F}} = 15\text{mV}$$

Although this meets DC ripple spec, however it needs to be studied for transient requirement.

### Based On Transient Requirement

Typically, the output voltage droop during transient is specified as:

$$\Delta V_{\text{DROOP}} < \Delta V_{\text{TRAN}} \text{ @ step load } \Delta I_{\text{STEP}}$$

During the transient, the voltage droop during the transient is composed of two sections. One Section is dependent on the ESR of capacitor, the other section is a function of the inductor, output capacitance as well as input, output voltage. For example, for the overshoot, when load from high load to light load with a  $\Delta I_{\text{STEP}}$  transient load, if assuming the bandwidth of system is high enough, the overshoot can be estimated as the following equation.

$$\Delta V_{\text{overshoot}} = \text{ESR} \times \Delta I_{\text{step}} + \frac{V_{\text{OUT}}}{2 \times L \times C_{\text{OUT}}} \times \tau^2 \quad \dots(6)$$

where  $\tau$  is the a function of capacitor, etc.

$$\tau = \begin{cases} 0 & \text{if } L \leq L_{\text{crit}} \\ \frac{L \times \Delta I_{\text{step}}}{V_{\text{OUT}}} - \text{ESR} \times C_{\text{OUT}} & \text{if } L \geq L_{\text{crit}} \end{cases} \quad \dots(7)$$

where

$$L_{\text{crit}} = \frac{\text{ESR} \times C_{\text{OUT}} \times V_{\text{OUT}}}{\Delta I_{\text{step}}} = \frac{\text{ESR}_E \times C_E \times V_{\text{OUT}}}{\Delta I_{\text{step}}} \quad \dots(8)$$

where  $\text{ESR}_E$  and  $C_E$  represents ESR and capacitance of each capacitor if multiple capacitors are used in parallel.

The above equation shows that if the selected output inductor is smaller than the critical inductance, the voltage droop or overshoot is only dependent on the ESR

of output capacitor. For low frequency capacitor such as electrolytic capacitor, the product of ESR and capacitance is high and  $L \leq L_{\text{crit}}$  is true. In that case, the transient spec is dependent on the ESR of capacitor.

In most cases, the output capacitors are multiple capacitors in parallel. The number of capacitors can be calculated by the following

$$N = \frac{\text{ESR}_E \times \Delta I_{\text{step}}}{\Delta V_{\text{tran}}} + \frac{V_{\text{OUT}}}{2 \times L \times C_E \times \Delta V_{\text{tran}}} \times \tau^2 \quad \dots(9)$$

where

$$\tau = \begin{cases} 0 & \text{if } L \leq L_{\text{crit}} \\ \frac{L \times \Delta I_{\text{step}}}{V_{\text{OUT}}} - \text{ESR}_E \times C_E & \text{if } L \geq L_{\text{crit}} \end{cases} \quad \dots(10)$$

For example, assume voltage droop during transient is 100mV for 9A load step.

If the SANYO electrolytic capacitor 16ME1500WG (1500uF, 13mΩ) is used, the critical inductance is given as

$$L_{\text{crit}} = \frac{\text{ESR}_E \times C_E \times V_{\text{OUT}}}{\Delta I_{\text{step}}} = \frac{13\text{m}\Omega \times 1500\mu\text{F} \times 1.8\text{V}}{9\text{A}} = 3.9\mu\text{H}$$

The selected inductor is 1.5uH which is smaller than critical inductance. In that case, the output voltage transient only dependent on the ESR.

number of capacitors is

$$\begin{aligned} N &= \frac{\text{ESR}_E \times \Delta I_{\text{step}}}{\Delta V_{\text{tran}}} + \frac{V_{\text{OUT}}}{2 \times L \times C_E \times \Delta V_{\text{tran}}} \times \tau^2 \\ &= \frac{13\text{m}\Omega \times 9\text{A}}{100\text{mV}} + \frac{1.8\text{V}}{2 \times 1.5\mu\text{H} \times 220\mu\text{F} \times 100\text{mV}} \times (0)^2 \\ &= 1.2 \end{aligned}$$

The number of capacitors has to satisfied both ripple and transient requirement. Overall, we can choose N=2.

It should be considered that the proposed equation is based on ideal case, in reality, the droop or overshoot is typically more than the calculation. The equation gives a good start. For more margin, more capacitors have to be chosen after the test. Typically, for high frequency capacitor such as high quality POSCAP especially ceramic capacitor, 20% to 100% (for ceramic) more capacitors have to be chosen since the ESR of capacitors is so low that the PCB parasitic can affect the results tremendously. More capacitors have to be selected to compensate these parasitic parameters.

### Compensator Design

Due to the double pole generated by LC filter of the power stage, the power system has 180° phase shift, and therefore, is unstable by itself. In order to achieve accurate output voltage and fast transient response, compensator is employed to provide highest possible bandwidth and enough phase margin. Ideally, the Bode plot of the closed loop system has crossover frequency between 1/10 and 1/5 of the switching frequency, phase margin greater than 50° and the gain crossing 0dB with -20dB/decade. Power stage output capacitors usually decide the compensator type. If electrolytic capacitors are chosen as output capacitors, type II compensator can be used to compensate the system, because the zero caused by output capacitor ESR is lower than crossover frequency. Otherwise type III compensator should be chosen.

#### A. Type III compensator design

For low ESR output capacitors, typically such as Sanyo oscap and poscap, the frequency of ESR zero caused by output capacitors is higher than the crossover frequency. In this case, it is necessary to compensate the system with type III compensator. The following figures and equations show how to realize the type III compensator by transconductance amplifier.

$$F_{Z1} = \frac{1}{2 \times \pi \times R_4 \times C_2} \quad \dots(11)$$

$$F_{Z2} = \frac{1}{2 \times \pi \times (R_2 + R_3) \times C_3} \quad \dots(12)$$

$$F_{P1} = \frac{1}{2 \times \pi \times R_3 \times C_3} \quad \dots(13)$$

$$F_{P2} = \frac{1}{2 \times \pi \times R_4 \times \frac{C_1 \times C_2}{C_1 + C_2}} \quad \dots(14)$$

where  $F_{Z1}, F_{Z2}, F_{P1}$  and  $F_{P2}$  are poles and zeros in the compensator. Their locations are shown in figure 4.

The transfer function of type III compensator for transconductance amplifier is given by:

$$\frac{V_e}{V_{OUT}} = \frac{1 - g_m \times Z_f}{1 + g_m \times Z_{in} + Z_{in} / R_1}$$

For the voltage amplifier, the transfer function of compensator is

$$\frac{V_e}{V_{OUT}} = \frac{-Z_f}{Z_{in}}$$

To achieve the same effect as voltage amplifier, the compensator of transconductance amplifier must satisfy this condition:  $R_4 \gg 2/g_m$ . And it would be desirable if  $R_1 || R_2 || R_3 \gg 1/g_m$  can be met at the same time.

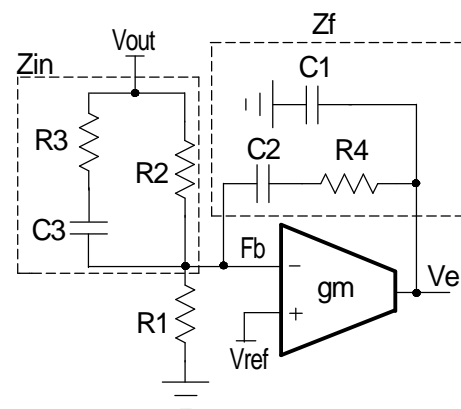

Figure 3 - Type III compensator using transconductance amplifier



Case 1:  $F_{LC} < F_O < F_{ESR}$

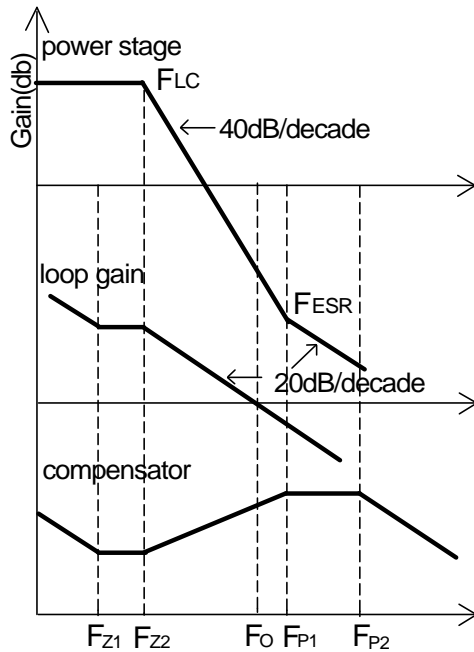

Figure 4 - Bode plot of Type III compensator

Design example for type III compensator are in order. The crossover frequency has to be selected as  $F_{LC} < F_O < F_{ESR}$  and  $F_O \leq 1/10 \sim 1/5 F_s$ . Here two POSCAP 2R5TPE220MC (220uF, 12 mΩ) are chosen as output capacitor.

1. Calculate the location of LC double pole  $F_{LC}$  and ESR zero  $F_{ESR}$ .

$$F_{LC} = \frac{1}{2 \times \pi \times \sqrt{L_{OUT} \times C_{OUT}}} = \frac{1}{2 \times \pi \times \sqrt{1.5\mu H \times 440\mu F}} = 6.2\text{kHz}$$

$$F_{ESR} = \frac{1}{2 \times \pi \times ESR \times C_{OUT}} = \frac{1}{2 \times \pi \times 6\text{m}\Omega \times 440\mu F} = 60.3\text{kHz}$$

2. Set  $R_2$  equal to 10kΩ.

$$R_1 = \frac{R_2 \times V_{REF}}{V_{OUT} - V_{REF}} = \frac{10\text{k}\Omega \times 0.8\text{V}}{1.8\text{V} - 0.8\text{V}} = 8\text{k}\Omega$$

Choose  $R_1 = 8\text{k}\Omega$ .

3. Set zero  $F_{Z2} = F_{LC}$  and  $F_{P1} = F_{ESR}$ .

4. Calculate  $R_4$  and  $C_3$  with the crossover frequency at 1/10~ 1/5 of the switching frequency. Set  $F_O = 30\text{kHz}$ .

$$C_3 = \frac{1}{2 \times \pi \times R_2} \times \left( \frac{1}{F_{Z2}} - \frac{1}{F_{P1}} \right) = \frac{1}{2 \times \pi \times 10\text{k}\Omega} \times \left( \frac{1}{6.2\text{kHz}} - \frac{1}{60.3\text{kHz}} \right) = 2.3\text{nF}$$

$$R_4 = \frac{V_{OSC}}{V_{in}} \times \frac{2 \times \pi \times F_O \times L}{C_3} \times C_{OUT} = \frac{1.5\text{V}}{5\text{V}} \times \frac{2 \times \pi \times 30\text{kHz} \times 1.5\mu H}{2.2\text{nF}} \times 440\mu F = 16.9\text{k}\Omega$$

Choose  $C_3 = 2.2\text{nF}$ ,  $R_4 = 16.9\text{k}\Omega$ .

5. Calculate  $C_2$  with zero  $F_{Z1}$  at 75% of the LC double pole by equation (11).

$$C_2 = \frac{1}{2 \times \pi \times F_{Z1} \times R_4} = \frac{1}{2 \times \pi \times 0.75 \times 6.2\text{kHz} \times 16.9\text{k}\Omega} = 2\text{nF}$$

Choose  $C_2 = 2.2\text{nF}$ .

6. Calculate  $C_1$  by equation (14) with pole  $F_{P2}$  at half the switching frequency.

$$C_1 = \frac{1}{2 \times \pi \times R_4 \times F_{P2}} = \frac{1}{2 \times \pi \times 16.9\text{k}\Omega \times 150\text{kHz}} = 63\text{pF}$$

Choose  $C_1 = 68\text{pF}$ .

7. Calculate  $R_3$  by equation (13).

$$R_3 = \frac{1}{2 \times \pi \times F_{P1} \times C_3} = \frac{1}{2 \times \pi \times 60.3\text{kHz} \times 2.2\text{nF}} = 1.2\text{k}\Omega$$

Choose  $R_3 = 1.2\text{k}\Omega$ .

Case 2:  $F_{LC} < F_{ESR} < F_O$

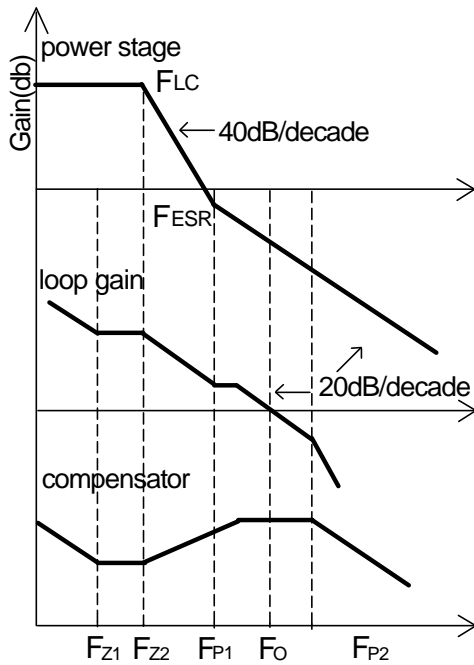

Figure 5 - Bode plot of Type III compensator  
( $F_{LC} < F_{ESR} < F_O$ )

If electrolytic capacitors are used as output capacitors, typical design example of type III compensator in which the crossover frequency is selected as  $F_{LC} < F_{ESR} < F_O$  and  $F_O \approx 1/10 \sim 1/5 F_s$  is shown as the following steps. Here two SANYO 16MV-WG1500 with 13 mΩ is chosen as output capacitor.

1. Calculate the location of LC double pole  $F_{LC}$  and ESR zero  $F_{ESR}$ :

$$F_{LC} = \frac{1}{2 \times \pi \times \sqrt{L_{OUT} \times C_{OUT}}} = \frac{1}{2 \times \pi \times \sqrt{1.5 \mu\text{H} \times 3000 \mu\text{F}}} = 2.3 \text{ kHz}$$

$$F_{ESR} = \frac{1}{2 \times \pi \times \text{ESR} \times C_{OUT}} = \frac{1}{2 \times \pi \times 6.5 \text{ m}\Omega \times 3000 \mu\text{F}} = 8.2 \text{ kHz}$$

2. Set  $R_2$  equal to 10kΩ.

$$R_1 = \frac{R_2 \times V_{REF}}{V_{OUT} - V_{REF}} = \frac{10 \text{ k}\Omega \times 0.8 \text{ V}}{1.8 \text{ V} - 0.8 \text{ V}} = 8 \text{ k}\Omega$$

Choose  $R_1 = 8.06 \text{ k}\Omega$ .

3. Set zero  $F_{Z2} = F_{LC}$  and  $F_{P1} = F_{ESR}$ .

4. Calculate  $C_3$ .

$$C_3 = \frac{1}{2 \times \pi \times R_2} \times \left( \frac{1}{F_{Z2}} - \frac{1}{F_{P1}} \right) = \frac{1}{2 \times \pi \times 10 \text{ k}\Omega} \times \left( \frac{1}{2.3 \text{ kHz}} - \frac{1}{8.2 \text{ kHz}} \right) = 4.76 \text{ nF}$$

Choose  $C_3 = 4.7 \text{ nF}$ .

5. Calculate  $R_3$ .

$$R_3 = \frac{1}{2 \times \pi \times F_{P1} \times C_3} = \frac{1}{2 \times \pi \times 8.2 \text{ kHz} \times 4.7 \text{ nF}} = 4.1 \text{ k}\Omega$$

Choose  $R_3 = 4 \text{ k}\Omega$ .

6. Calculate  $R_4$  with  $F_O = 30 \text{ kHz}$ .

$$R_4 = \frac{V_{OSC}}{V_{in}} \times \frac{2 \times \pi \times F_O \times L}{\text{ESR}} \times \frac{R_2 \times R_3}{R_2 + R_3} = \frac{1.5 \text{ V}}{5 \text{ V}} \times \frac{2 \times \pi \times 30 \text{ kHz} \times 1.5 \mu\text{H}}{6.5 \text{ m}\Omega} \times \frac{10 \text{ k}\Omega \times 4 \text{ k}\Omega}{10 \text{ k}\Omega + 4 \text{ k}\Omega} = 37.3 \text{ k}\Omega$$

Choose  $R_4 = 37.4 \text{ k}\Omega$ .

7. Calculate  $C_2$  with zero  $F_{Z1}$  at 75% of the LC double pole by equation (11).

$$C_2 = \frac{1}{2 \times \pi \times F_{Z1} \times R_4} = \frac{1}{2 \times \pi \times 0.75 \times 2.3 \text{ kHz} \times 37.4 \text{ k}\Omega} = 2.4 \text{ nF}$$

Choose  $C_2 = 2.2 \text{ nF}$ .

8. Calculate  $C_1$  by equation (14) with pole  $F_{P2}$  at half the switching frequency.

$$C_1 = \frac{1}{2 \times \pi \times R_4 \times F_{P2}} = \frac{1}{2 \times \pi \times 37.4 \text{ k}\Omega \times 150 \text{ kHz}} = 28 \text{ pF}$$

Choose  $C_1 = 27 \text{ pF}$ .

## B. Type II compensator design

If the electrolytic capacitors are chosen as power stage output capacitors, usually the Type II compensator can be used to compensate the system.

Type II compensator can be realized by simple RC circuit without feedback as shown in figure 6.  $R_3$  and  $C_1$  introduce a zero to cancel the double pole effect.  $C_2$  introduces a pole to suppress the switching noise. The following equations show the compensator pole zero location and constant gain.

$$\text{Gain} = g_m \times \frac{R_1}{R_1 + R_2} \times R_3 \quad \dots (15)$$

$$F_z = \frac{1}{2 \times \pi \times R_3 \times C_1} \quad \dots (16)$$

$$F_p \approx \frac{1}{2 \times \pi \times R_3 \times C_2} \quad \dots (17)$$

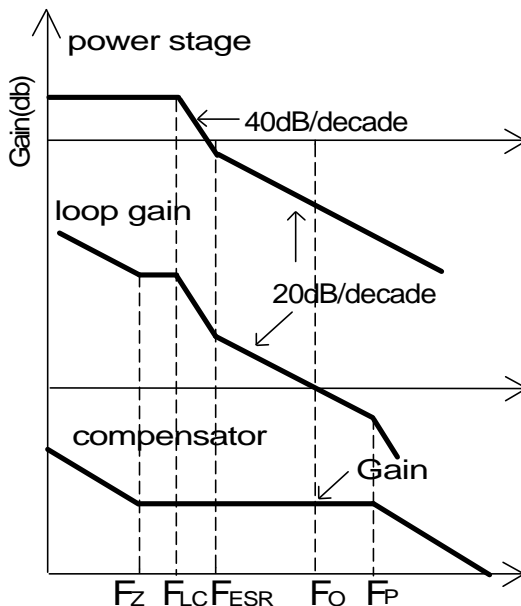

Figure 6 - Bode plot of Type II compensator

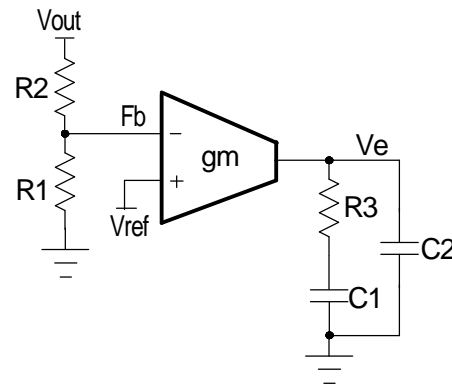

Figure 7 - Type II compensator with transconductance amplifier

For this type of compensator,  $F_o$  has to satisfy  $F_{LC} < F_{ESR} \ll F_o \leq 1/10 \sim 1/5 F_s$ .

The following is parameters for type II compensator design. Input voltage is 5V, output voltage is 1.8V, output inductor is 1.5uH, output capacitors are two 1500uF with 13mΩ electrolytic capacitors.

1. Calculate the location of LC double pole  $F_{LC}$  and ESR zero  $F_{ESR}$ .

$$F_{LC} = \frac{1}{2 \times \pi \times \sqrt{L_{OUT} \times C_{OUT}}} = \frac{1}{2 \times \pi \times \sqrt{1.5\mu\text{H} \times 3000\mu\text{F}}} = 2.3\text{kHz}$$

$$F_{ESR} = \frac{1}{2 \times \pi \times \text{ESR} \times C_{OUT}} = \frac{1}{2 \times \pi \times 6.5\text{m}\Omega \times 3000\mu\text{F}} = 8.2\text{kHz}$$

2. Set  $R_2$  equal to 1kΩ.

$$R_1 = \frac{R_2 \times V_{REF}}{V_{OUT} - V_{REF}} = \frac{1\text{k}\Omega \times 0.8\text{V}}{1.8\text{V} - 0.8\text{V}} = 800\Omega$$

Choose  $R_1 = 800\Omega$ .

3. Set crossover frequency at 1/10~ 1/5 of the switching frequency, here  $F_o = 30\text{kHz}$ .

4. Calculate  $R_3$  value by the following equation.

4. Calculate  $R_3$  value by the following equation.

$$\begin{aligned}
 R_3 &= \frac{V_{OSC}}{V_{in}} \times \frac{2 \times \pi \times F_o \times L}{R_{ESR}} \times \frac{1}{g_m} \times \frac{V_{OUT}}{V_{REF}} \\
 &= \frac{1.5V}{5V} \times \frac{2 \times \pi \times 30kHz \times 1.5\mu H}{6.5m\Omega} \times \frac{1}{2.0mA/V} \\
 &\quad \times \frac{1.8V}{0.8V} \\
 &= 14.6k\Omega
 \end{aligned}$$

Choose  $R_3 = 14.7k\Omega$ .

5. Calculate  $C_1$  by setting compensator zero  $F_z$  at 75% of the LC double pole.

$$\begin{aligned}
 C_1 &= \frac{1}{2 \times \pi \times R_3 \times F_z} \\
 &= \frac{1}{2 \times \pi \times 14.7k\Omega \times 0.75 \times 2.3kHz} \\
 &= 6.3nF
 \end{aligned}$$

Choose  $C_1 = 6.8nF$ .

6. Calculate  $C_2$  by setting compensator pole  $F_p$  at half the switching frequency.

$$\begin{aligned}
 C_2 &= \frac{1}{\pi \times R_3 \times F_s} \\
 &= \frac{1}{\pi \times 14.7k\Omega \times 300kHz} \\
 &= 72pF
 \end{aligned}$$

Choose  $C_2 = 68pF$ .

## Output Voltage Calculation

Output voltage is set by reference voltage and external voltage divider. The reference voltage is fixed at 0.8V. The divider consists of two ratioed resistors so that the output voltage applied at the Fb pin is 0.8V when the output voltage is at the desired value. The following equation and picture show the relationship between  $V_{OUT}$ ,  $V_{REF}$  and voltage divider.

$$R_1 = \frac{R_2 \times V_{REF}}{V_{OUT} - V_{REF}} \quad \dots(18)$$

where  $R_2$  is part of the compensator, and the value of  $R_1$  value can be set by voltage divider.

See compensator design for  $R_1$  and  $R_2$  selection.

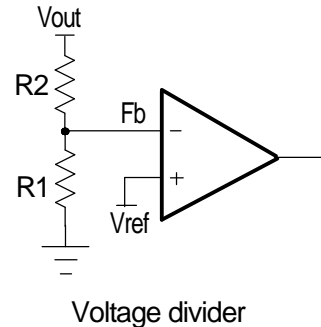

Figure 8 - Voltage divider

## Input Capacitor Selection

Input capacitors are usually a mix of high frequency ceramic capacitors and bulk capacitors. Ceramic capacitors bypass the high frequency noise, and bulk capacitors supply switching current to the MOSFETs. Usually 1uF ceramic capacitor is chosen to decouple the high frequency noise. The bulk input capacitors are decided by voltage rating and RMS current rating. The RMS current in the input capacitors can be calculated as:

$$\begin{aligned}
 I_{RMS} &= I_{OUT} \times \sqrt{D} \times \sqrt{1-D} \\
 D &= \frac{V_{OUT}}{V_{IN}} \quad \dots(19)
 \end{aligned}$$

$V_{IN} = 5V$ ,  $V_{OUT} = 1.8V$ ,  $I_{OUT} = 9A$ , using equation (19), the result of input RMS current is 4.3A.

For higher efficiency, low ESR capacitors are recommended. One Sanyo OS-CON 16SP270M 16V 270uF 18mΩ with 4.4A RMS rating are chosen as input bulk capacitors.

## Power MOSFETs Selection

The power stage requires two N-Channel power MOSFETs. The selection of MOSFETs is based on maximum drain source voltage, gate source voltage, maximum current rating, MOSFET on resistance and power dissipation. The main consideration is the power loss contribution of MOSFETs to the overall converter efficiency. In this design example, two IRFR3706 are used. They have the following parameters:  $V_{DS} = 30V$ ,  $I_D = 75A$ ,  $R_{DS(on)} = 9m\Omega$ ,  $Q_{GATE} = 23nC$ .

There are two factors causing the MOSFET power loss: conduction loss, switching loss.

Conduction loss is simply defined as:

$$\begin{aligned}
 P_{HCON} &= I_{OUT}^2 \times D \times R_{DS(ON)} \times K \\
 P_{LCON} &= I_{OUT}^2 \times (1-D) \times R_{DS(ON)} \times K \\
 P_{TOTAL} &= P_{HCON} + P_{LCON}
 \end{aligned}
 \quad \dots(20)$$

where the  $R_{DS(ON)}$  will increase as MOSFET junction temperature increases,  $K$  is  $R_{DS(ON)}$  temperature dependency. As a result,  $R_{DS(ON)}$  should be selected for the worst case, in which  $K$  approximately equals to 1.4 at 125°C according to IRFR3706 datasheet. Conduction loss should not exceed package rating or overall system thermal budget.

Switching loss is mainly caused by crossover conduction at the switching transition. The total switching loss can be approximated.

$$P_{SW} = \frac{1}{2} \times V_{IN} \times I_{OUT} \times T_{SW} \times F_S \quad \dots(21)$$

where  $I_{OUT}$  is output current,  $T_{SW}$  is the sum of  $T_R$  and  $T_F$  which can be found in mosfet datasheet, and  $F_S$  is switching frequency. Switching loss  $P_{SW}$  is frequency dependent.

Also MOSFET gate driver loss should be considered when choosing the proper power MOSFET. MOSFET gate driver loss is the loss generated by discharging the gate capacitor and is dissipated in driver circuits. It is proportional to frequency and is defined as:

$$P_{gate} = (Q_{HGATE} \times V_{HGS} + Q_{LGATE} \times V_{LGS}) \times F_S \quad \dots(22)$$

where  $Q_{HGATE}$  is the high side MOSFETs gate charge,  $Q_{LGATE}$  is the low side MOSFETs gate charge,  $V_{HGS}$  is the high side gate source voltage, and  $V_{LGS}$  is the low side gate source voltage.

This power dissipation should not exceed maximum power dissipation of the driver device.

## Over Current Limit Protection

Over current Limit for step down converter is achieved by sensing current through the low side MOSFET. For NX2124, the current limit is decided by the  $R_{DS(ON)}$  of the low side mosfet. When synchronous FET is on, and the voltage on SW pin is below 360mV, the over current occurs. The over current limit can be calculated by the following equation.

$$I_{SET} = \frac{360mV}{K \times R_{DS(ON)}}$$

If MOSFET  $R_{DS(ON)} = 9m\Omega$ , the worst case thermal consideration  $K=1.5$ , then

$$I_{SET} = \frac{320mV}{K \times R_{DS(ON)}} = \frac{360mV}{1.5 \times 9m\Omega} = 26.7A$$

## Layout Considerations

The layout is very important when designing high frequency switching converters. Layout will affect noise pickup and can cause a good design to perform with less than expected results.

There are two sets of components considered in the layout which are power components and small signal components. Power components usually consist of input capacitors, high-side MOSFET, low-side MOSFET, inductor and output capacitors. A noisy environment is generated by the power components due to the switching power. Small signal components are connected to sensitive pins or nodes. A multilayer layout which includes power plane, ground plane and signal plane is recommended.

Layout guidelines:

1. First put all the power components in the top layer connected by wide, copper filled areas. The input capacitor, inductor, output capacitor and the MOSFETs should be close to each other as possible. This helps to reduce the EMI radiated by the power loop due to the high switching currents through them.

2. Low ESR capacitor which can handle input RMS ripple current and a high frequency decoupling ceramic cap which usually is 1uF need to be practically touching the drain pin of the upper MOSFET, a plane connection is a must.

3. The output capacitors should be placed as close as to the load as possible and plane connection is required.

4. Drain of the low-side MOSFET and source of the high-side MOSFET need to be connected thru a plane as close as possible. A snubber needs to be placed as close to this junction as possible.

5. Source of the lower MOSFET needs to be con-

connected to the GND plane with multiple vias. One is not enough. This is very important. The same applies to the output capacitors and input capacitors.

6. Hdrv and Ldrv pins should be as close to MOSFET gate as possible. The gate traces should be wide and short. A place for gate drv resistors is needed to fine tune noise if needed.

7. Vcc capacitor, BST capacitor or any other bypassing capacitor needs to be placed first around the IC and as close as possible. The capacitor on comp to GND or comp back to FB needs to be placed as close to the pin as well as resistor divider.

8. The output sense line which is sensing output

back to the resistor divider should not go through high frequency signals.

9. All GNDs need to go directly thru via to GND plane.

10. The feedback part of the system should be kept away from the inductor and other noise sources, and be placed close to the IC.

11. In multilayer PCB, separate power ground and analog ground. These two grounds must be connected together on the PC board layout at a single point. The goal is to localize the high current path to a separate loop that does not interfere with the more sensitive analog control function.

## TYPICAL APPLICATION

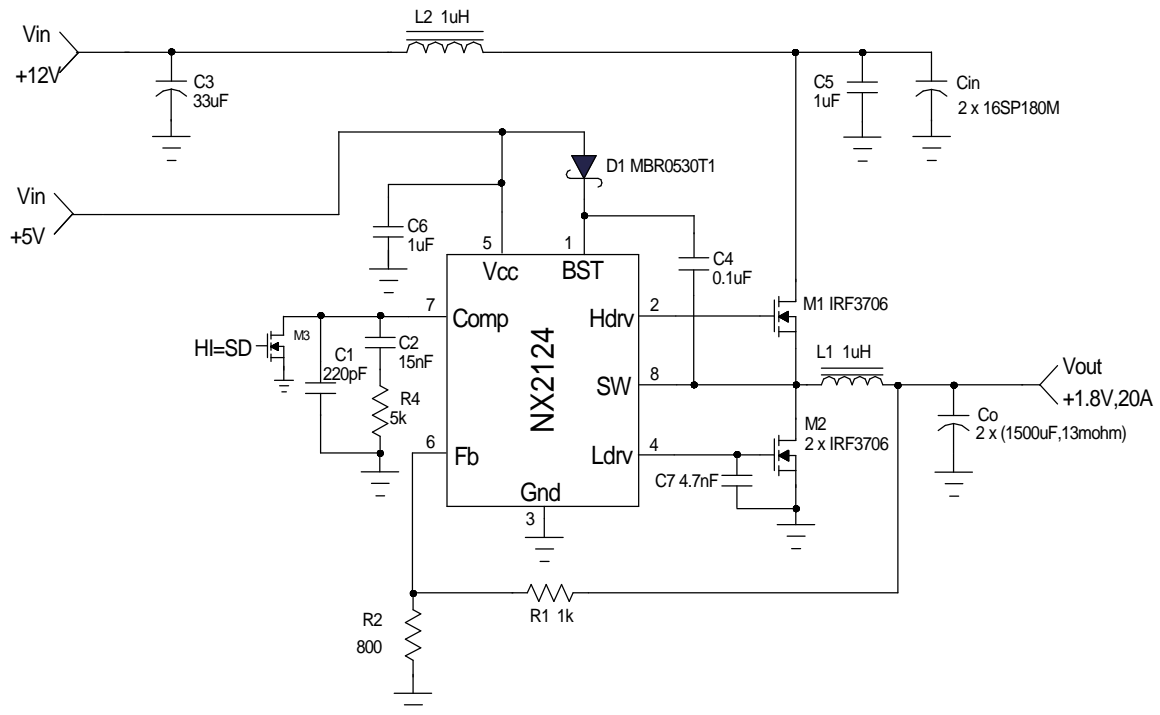
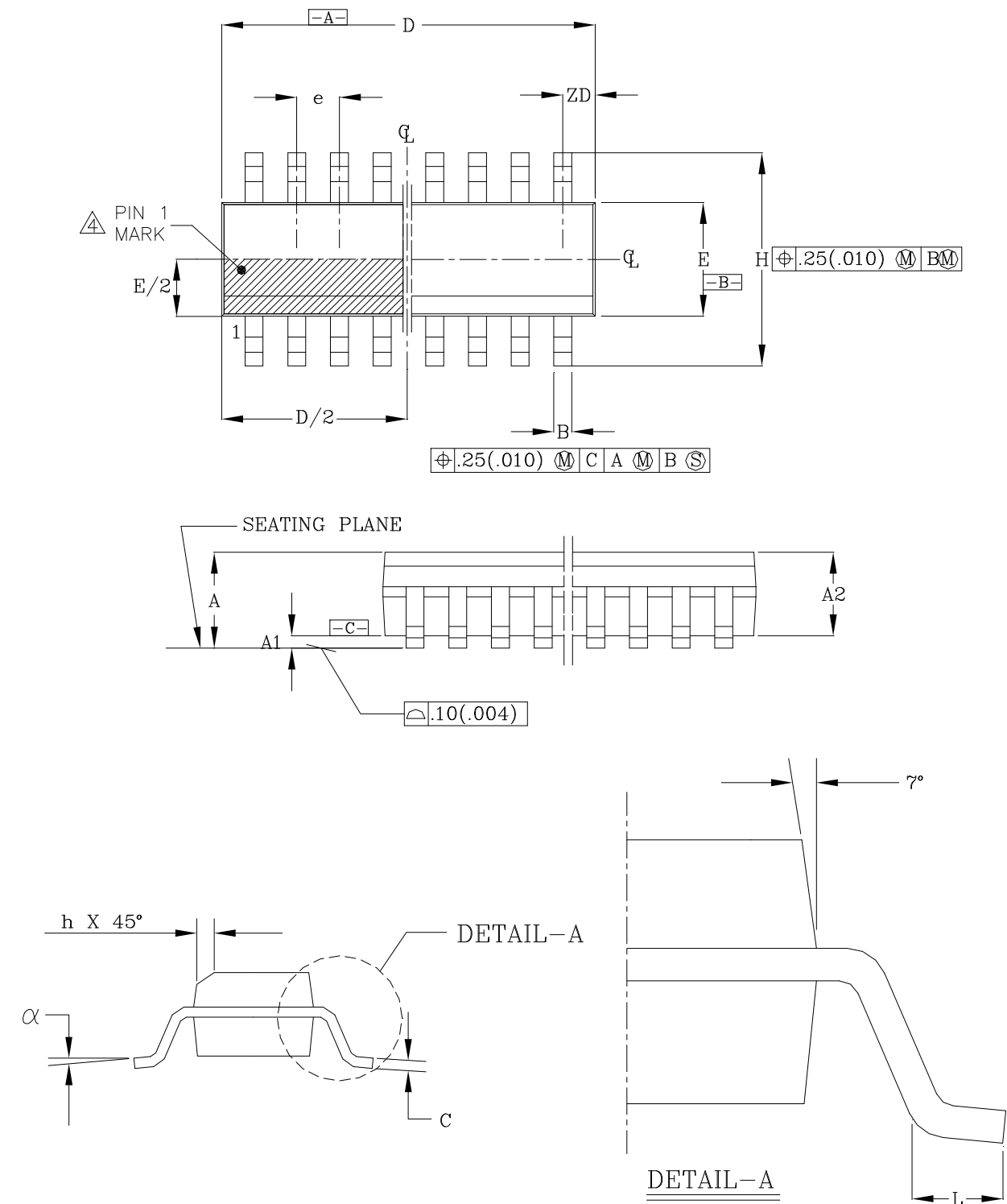

Figure 9 - High output current application of 2124

**SOIC8 PACKAGE OUTLINE DIMENSIONS**

SYMBOL	SOIC-8LD	
	MILLIMETERS	
	MIN	MAX
A1	0.10	0.25
B	0.36	0.46
C	0.19	0.25
D	4.80	4.98
E	3.81	3.99
e	1.27 BSC	
H	5.80	6.20
h	0.25	0.50
L	0.41	1.27
A	1.52	1.72
$\alpha$	0°	8°
ZD	0.53	REF
A2	1.37	1.57

SYMBOL	SOIC-8LD	
	INCHES	
	MIN	MAX
A1	.0040	.0098
B	.014	.018
C	.0075	.0098
D	.189	.196
E	.150	.157
e	.050 BSC	
H	.2284	.2440
h	.0099	.0196
L	.016	.050
A	.060	.068
$\alpha$	0°	8°
ZD	.021	REF
A2	.054	.062

NOTES :

1. LEAD COPLANARITY SHOULD BE 0 TO 0.10MM (.004") MAX.
  2. PACKAGE SURFACE FINISHING :
    - (2.1) TOP : MATTE (CHARMILLES #18~30).
    - (2.2) ALL SIDES : MATTE (CHARMILLES #18~30).
    - (2.3) BOTTOM : SMOOTH OR MATTE (CHARMILLES #18~30).
  3. ALL DIMENSIONS EXCLUDING MOLD FLASHES AND END FLASH FROM THE PACKAGE BODY SHALL NOT EXCEED 0.25MM (.010") PER SIDE(D).
- ⚠️ DETAIL OF PIN #1 IDENTIFIER ARE OPTIONAL BUT MUST BE LOCATED WITHIN THE ZONE INDICATED.



**Customer Service****NEXSEM Inc.****500 Wald****Irvine, CA 92618****U.S.A.****Tel: (949)453-0714****Fax: (949)453-0713****WWW.NEXSEM.COM**