

**DESCRIPTION**

The popular 1N941 thru 1N946B series of Zero-TC Reference Diodes provides a selection of 11.7 V nominal voltages and temperature coefficients to as low as 0.0002%/°C for minimal voltage change with temperature when operated at 7.5 mA. These glass axial-leaded DO-7 reference diodes are also available in JAN, JANTX, and JANTXV military qualifications. Microsemi also offers numerous other Zener Reference Diode products for a variety of other voltages from 6.2 V to 200 V.

**APPEARANCE**

**DO-7  
(DO-204AA)**

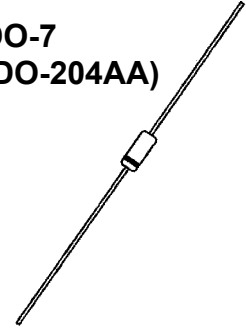

**IMPORTANT:** For the most current data, consult MICROSEMI's website: <http://www.microsemi.com>

**FEATURES**

- JEDEC registered 1N941 thru 1N946B series
- Standard reference voltage of 11.7 V +/- 5% with tighter tolerances also available
- 1N941B, 942B, 943B, 944B, 945B also have military qualification to MIL-PRF-19500/157 up to the JANTXV level by adding JAN, JANTX, or JANTXV prefixes to part numbers as well as "-1" suffix, e.g. JANTX1N944B-1, etc.
- Internal metallurgical bonds
- JANS Equivalent available via SCD
- Radiation Hardened devices available by changing "1N" prefix to "RH", e.g. RH944B, RH945B, etc. Also consult factory for "RH" data sheet brochure

**APPLICATIONS / BENEFITS**

- Provides minimal voltage changes over a broad temperature range
- For instrumentation and other circuit designs requiring a stable voltage reference
- Maximum temperature coefficient selections available from 0.01%/°C to 0.0002%/°C
- Tight reference voltage tolerances available at 11.7 V nominal values by adding the tolerance 1%, 2%, 3%, etc. after the part number for further identification e.g. 1N944B-2%, 1N945A-1%, 1N944B-1-1%, etc.
- Flexible axial-lead mounting terminals
- Nonsensitive to ESD per MIL-STD-750 Method 1020

**MAXIMUM RATINGS**

- Operating & Storage Temperature: -65°C to +175°C
- DC Power Dissipation: 500 mW @ T<sub>L</sub> = 25°C and maximum current I<sub>ZM</sub> of 39 mA. NOTE: For optimum voltage-temperature stability, I<sub>Z</sub> = 7.5 mA (less than 95 mW in dissipated power)
- Solder temperatures: 260 °C for 10 s (maximum)

**MECHANICAL AND PACKAGING**

- CASE: Hermetically sealed glass case with DO-7 (DO-204AA) package
- TERMINALS: Tin-lead plated and solderable per MIL-STD-750, Method 2026
- MARKING: Part number and cathode band
- POLARITY: Reference diode to be operated with the banded end positive with respect to the opposite end
- TAPE & REEL option: Standard per EIA-296 (add "TR" suffix to part number)
- WEIGHT: 0.2 grams.
- See package dimensions on last page

**\*ELECTRICAL CHARACTERISTICS @ 25°C, unless otherwise specified**

JEDEC TYPE NUMBER (Note 1, 5 & 6)	ZENER VOLTAGE $V_z @ I_{zT}$ (Note 4)	ZENER TEST CURRENT $I_{zT}$	MAXIMUM ZENER IMPEDANCE (Note 2) $Z_{zT} @ I_{zT}$	MAXIMUM REVERSE CURRENT $I_R @ 8 V$	VOLTAGE TEMPERATURE STABILITY (Note 3 & 4) $\Delta V_{zT}$ MAXIMUM	TEMPERATURE RANGE	EFFECTIVE TEMPERATURE COEFFICIENT $\alpha_{vz}$
	VOLTS	mA	OHMS	$\mu A$	mV	$^{\circ}C$	$\%/^{\circ}C$
1N941	11.12-12.28	7.5	30	15	88	0 to +75	0.01
1N941A	11.12-12.28	7.5	30	15	181	-55 to +100	0.01
1N941B	11.12-12.28	7.5	30	15	239	-55 to +150	0.01
1N942	11.12-12.28	7.5	30	15	44	0 to +75	0.005
1N942A	11.12-12.28	7.5	30	15	90	-55 to +100	0.005
1N942B	11.12-12.28	7.5	30	15	120	-55 to +150	0.005
1N943	11.12-12.28	7.5	30	15	18	0 to +75	0.002
1N943A	11.12-12.28	7.5	30	15	36	-55 to +100	0.002
1N943B	11.12-12.28	7.5	30	15	47	-55 to +150	0.002
1N944	11.12-12.28	7.5	30	15	9	0 to +75	0.001
1N944A	11.12-12.28	7.5	30	15	18	-55 to +100	0.001
1N944B	11.12-12.28	7.5	30	15	24	-55 to +150	0.001
1N945	11.12-12.28	7.5	30	15	4	0 to +75	0.0005
1N945A	11.12-12.28	7.5	30	15	9	-55 to +100	0.0005
1N945B	11.12-12.28	7.5	30	15	12	-55 to +150	0.0005
1N946	11.12-12.28	7.5	30	15	1.8	0 to +75	0.0002
1N946A	11.12-12.28	7.5	30	15	3.6	-55 to +100	0.0002
1N946B	11.12-12.28	7.5	30	15	4.7	-55 to +150	0.0002

\*JEDEC Registered Data.

**NOTES:**

- For tighter voltages tolerances, add a hyphenated suffix to the part number for desired tolerance at the end of the part number, e.g. 1N944B-2%, 1N945B-1%, 1N944B-1-1%, etc.
- Measured by superimposing 0.75 mA ac rms on 7.5 mA dc @ 25°C.
- The maximum allowable change observed over the entire temperature range i.e., the diode voltage will not exceed the specified mV change at any discrete temperature between the established limits.
- Voltage measurements to be performed 15 seconds after application of dc current.
- The 1N941B, 1N942B, 1N943B, 1N944B, 1N945B also have military qualification to MIL-PRF-19500/157 up to the JANTXV level by adding JAN, JANTX, or JANTXV prefixes to part numbers as well as "-1" suffix, e.g. JANTX1N944B-1, JANTXV1N945B-1, etc.
- Designate Radiation Hardened devices with "RH" prefix instead of "1N", i.e. RH944B instead of 1N944B.

**GRAPHS**

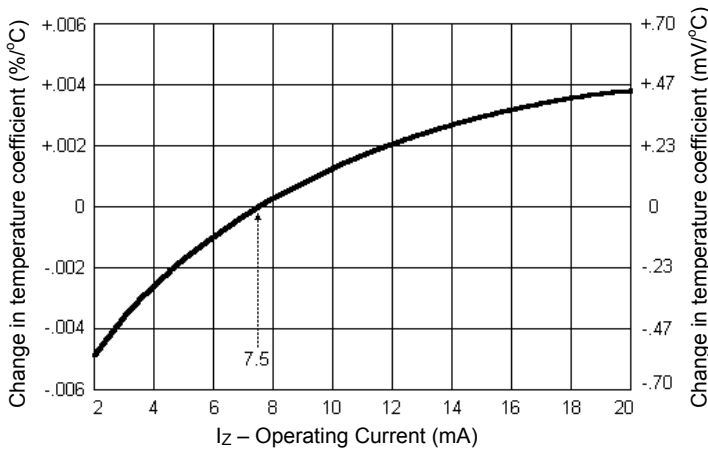

**FIGURE 1**

TYPICAL CHANGE OF TEMPERATURE COEFFICIENT WITH CHANGE IN OPERATING CURRENT.

The curve shown in Figure 1 is typical of the diode series and greatly simplifies the estimation of the Temperature Coefficient (TC) when the diode is operated at currents other than 7.5mA.

**EXAMPLE:** A diode in this series is operated at a current of 7.5mA and has specified Temperature Coefficient (TC) limits of +/-0.002%/°C. To obtain the typical Temperature Coefficient limits for this same diode operated at a current of 6.0mA, the new TC limits (%/°C) can be estimated using the graph in FIGURE 1.

At a test current of 6.0mA the change in Temperature Coefficient (TC) is approximately -0.0009%/°C. The algebraic sum of +/-0.002%/°C and -0.0009%/°C gives the new estimated limits of +0.0011%/°C and -0.0029%/°C.

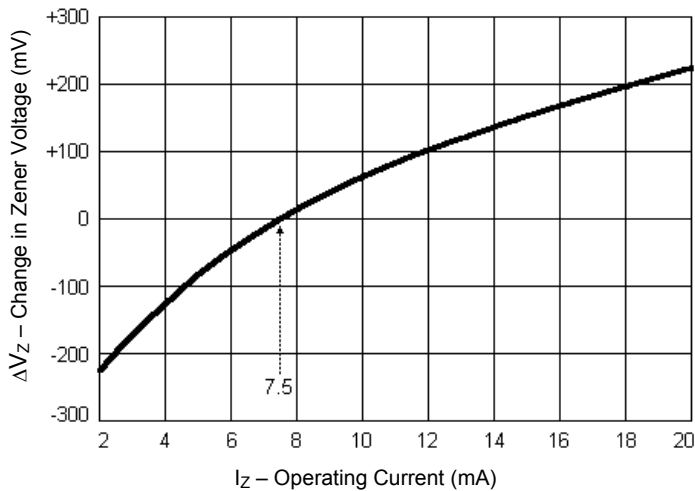

*This curve in Figure 2 illustrates the change of diode voltage arising from the effect of impedance. It is in effect, an exploded view of the zener operating region of the I-V characteristic.*

*In conjunction with Figure 1, this curve can be used to estimate total voltage regulation under conditions of both varying temperature and current.*

**FIGURE 2**  
TYPICAL CHANGE OF ZENER VOLTAGE WITH CHANGE IN OPERATING CURRENT.

**DIMENSIONS**

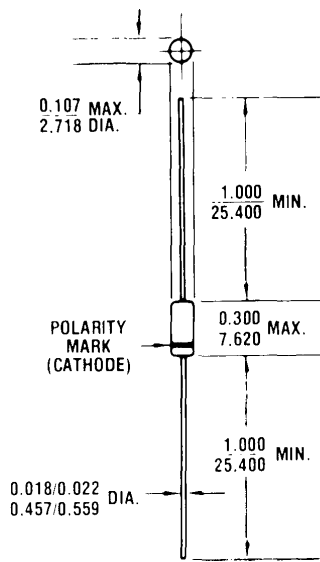

All dimensions in INCH  
mm