

CIRCUIT SIZE	DIM. "A"	DIM. "B"
2	—	—
4	.59 (15.0)	.165 (4.20)
6	.76 (19.2)	.331 (8.40)
8	.92 (23.4)	.496 (12.60)
10	1.09 (27.6)	.661 (16.80)
12	1.25 (31.8)	.827 (21.00)
14	1.42 (36.0)	.992 (25.20)
16	1.58 (40.2)	1.157 (29.40)
18	1.75 (44.4)	1.323 (33.60)
20	1.91 (48.6)	1.488 (37.80)
22	2.08 (52.8)	1.654 (42.00)
24	2.24 (57.0)	1.819 (46.20)

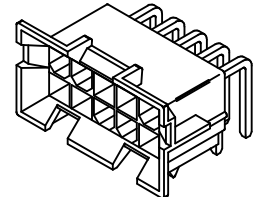

A-44499-*

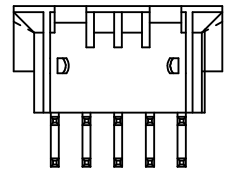
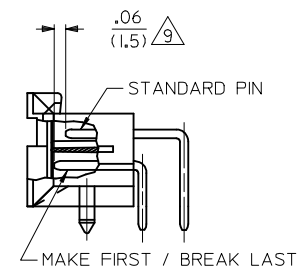
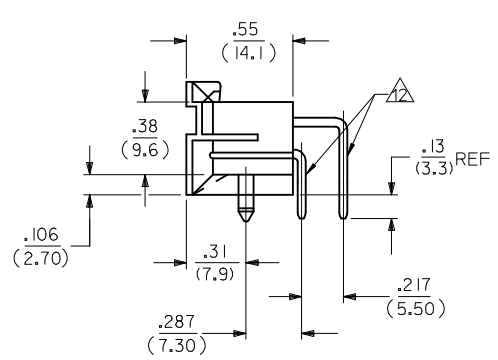
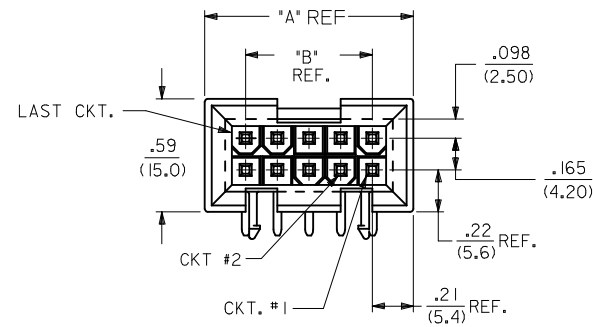
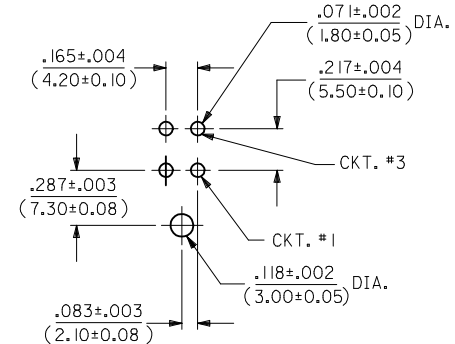
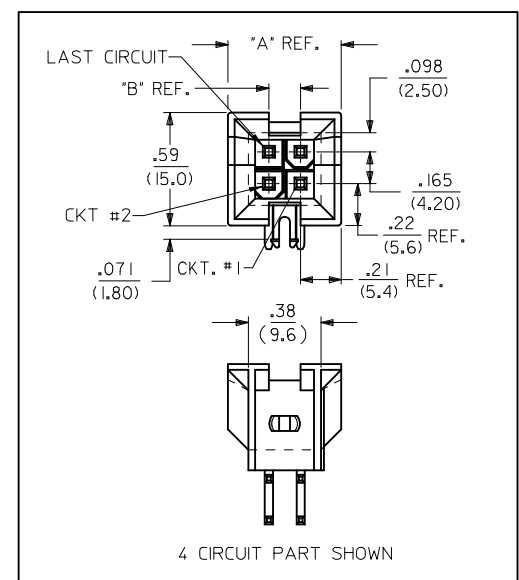

4 CIRCUIT PCB LAYOUT
RECOMMENDED HOLE LAYOUT FOR
.070/(1.78) MAX. THICK P.C. BOARD
VIEWED FROM COMPONENT SIDE

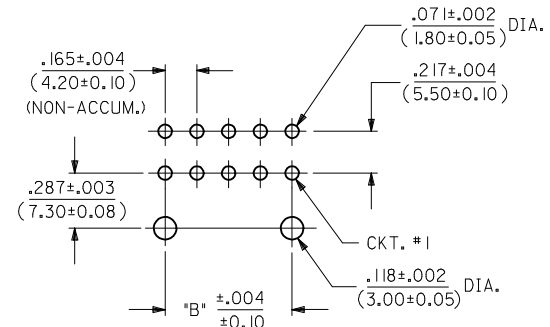

RECOMMENDED HOLE LAYOUT FOR
.070/(1.78) MAX. THICK P.C. BOARD
VIEWED FROM COMPONENT SIDE

- NOTES:
- MATERIAL:
HOUSING: "A" = NYLON 6/6, UL 94V-2, COLOR: NATURAL
"B" = NYLON 6/6, UL 94V-0, COLOR: NATURAL
TERMINALS: BRASS
 - TERMINAL PLATING:
C = .000030/(.00076) MIN. SELECT GOLD AND
.000100/(.00254) MIN. MATTE TIN OVER
.000050/(.00127) MIN. NICKEL OVERALL.
D = .000100/(.00254) MIN. MATTE TIN OVER
.000050/(.00127) MIN. NICKEL OVERALL.
 - PRODUCT SPECIFICATION: PS-5556-002
 - PACKAGING: TRAY PACKED PER MOLEX SPECIFICATION PK-42404-002.
 - PART MATES WITH MINI-FIT JR. RECEPTACLE 5557, 42385, 42474 AND 44516. 2 CIRCUIT PARTS MATE WITH 42385, 42474, AND 44516 ONLY.
 - PART ALLOWS FOR UP TO .100/(2.54) MISALIGNMENT WITH MATING RECEPTACLE IN ANY DIRECTION. SEE MATING CONNECTOR DRAWINGS FOR SPECIFIC ALLOWANCES.
 - PART IS NOT DESIGNED FOR CURRENT SHARING.
 - CONNECTOR ASSEMBLIES ARE NOT TO BE MATED OR UNMATED WHILE CIRCUITS ARE LIVE.
 - CIRCUITS SHOWN PROVIDE THE "MAKE-FIRST/BREAK-LAST" FEATURE.
 - PART CONFORMS TO CLASS B OF COSMETIC SPECIFICATION PS-45499-002.
 - DISCOLORATION IN THE BANDOLIER CARRIER AREA OF THE PIN IS INHERENT TO THE PLATING PROCESS AND IS DUE TO THE MASKING EFFECT OF THE CARRIER. THIS DISCOLORATION IS IN A NON-FUNCTIONAL AREA OF THE PIN AND WILL NOT AFFECT THE PERFORMANCE OF THE HEADER ASSEMBLY.
 - FORMING MARKS ARE ACCEPTABLE

ADD 4499-0131 EC NO: UCP2018-0545 DRWINBAPPELDORN 2017/10/11 CHKD:JBELL 2017/10/11 APPR:FSMITH 2017/10/13	DESCRIPTION	QUALITY SYMBOLS	GENERAL TOLERANCES (UNLESS SPECIFIED)	DIMENSION STYLE	SCALE	DESIGN UNITS	THIRD ANGLE PROJECTION
		▽=0 ▽=0 ▽=0	mm INCH	IN/MM	2:1	METRIC	
D21	REVISION	4 PLACES ± --- ± ---	DRAWN BY DATE	AFG 1994/09/13	TITLE	DOCUMENT NO.	SHEET NO.
		3 PLACES ± --- ± .010	CHECKED BY DATE	RJF 1994/09/13			
		2 PLACES ± 0.25 ± .015	APPROVED BY DATE	FSMITH 2011/08/03	SDA-44499-*	1 OF 3	A
		0 PLACE ± ±	MATERIAL NO.	SEE CHART			
		ANGULAR ±1/2°	DRAFT WHERE APPLICABLE MUST REMAIN WITHIN DIMENSIONS		THIS DRAWING CONTAINS INFORMATION THAT IS PROPRIETARY TO MOLEX INCORPORATED AND SHOULD NOT BE USED WITHOUT WRITTEN PERMISSION		

ITEM NO.	CKT. SIZE	CHARACTERISTIC DESCRIPTION	LETTER INDICATES PIN PLATING AND LENGTH REQUIRED AT EACH CIRCUIT LOCATION. SEE NOTE 2 ON SHEET 1.																							
			1	2	3	4	5	6	7	8	9	10	11	12	13	14	15	16	17	18	19	20	21	22	23	24
44499-0005	24	24BC	CM	CM	CM	CM	CM	CM	CM	CM	CM	CS	CM	CM	CM	CM	CM	CM	CM	CM	CM	CM	CM	CM	CM	
44499-0006	04	04BC	CS	CM	CM	CS	-	-	-	-	-	-	-	-	-	-	-	-	-	-	-	-	-	-	-	
44499-0027	10	10BD	DS	DM	DM	DM	DM	DM	DM	DM	DM	DM	-	-	-	-	-	-	-	-	-	-	-	-	-	
44499-0029	24	24BD	DM	DM	DM	DM	DM	DM	DM	DM	DM	DM	DM	DM	DM	DM	DM	DM	DM	DM	DM	DM	DM	DM	DM	
44499-0036	24	24BD	DS	DS	DM	DM	DS	DS	DM	DS	DS	DS	DS	DS	DM	DM	DM	DS	DS	DS	DS	DS	DM	DS	DS	
44499-0041	14	14AD	DS	DS	DS	V	DS	DS	DS	DM	DS	DS	V	DS	DS	DM	-	-	-	-	-	-	-	-	-	
44499-0042	10	10BC	CS	CS	CS	CS	CS	CS	CS	CS	CS	CM	-	-	-	-	-	-	-	-	-	-	-	-	-	
44499-0049	24	24AD	DM	DM	DM	DM	DS	DS	DS	DS	DS	DS	DS	DS	DS	DS	DS	DS	DS	DS	DS	DS	DS	DS	DS	
44499-0055	10	10BC	CS	CM	CM	CM	CM	CM	CM	CM	CM	CM	-	-	-	-	-	-	-	-	-	-	-	-	-	
44499-0061	06	06BD	DM	DM	DM	DM	DM	DM	-	-	-	-	-	-	-	-	-	-	-	-	-	-	-	-	-	
44499-0065	24	24BC	CS	CM	CM	CM	CM	CM	CM	CM	CM	CM	CM	CM	CM	CM	DS	CM	CM	CM	CM	CM	CM	CM	CS	
44499-0066	18	18BD	DS	DS	DS	DS	DS	DS	DS	DS	DS	DS	DS	DS	DS	DM	DS	DS	DS	DM	-	-	-	-	-	
44499-0072	18	18BC	CS	CS	CS	CM	CM	CM	CM	CM	CS	CS	CM	CM	CM	CM	CM	CM	CS	-	-	-	-	-	-	
44499-0073	06	06BC	CS	CM	CM	CM	CM	CM	-	-	-	-	-	-	-	-	-	-	-	-	-	-	-	-	-	
44499-0075	18	18AD	DM	DS	DS	DS	DS	DS	DS	DS	DS	DS	DS	DS	DS	DS	DS	DS	DM	-	-	-	-	-	-	
44499-0078	18	18BC	CS	CM	CM	CM	CM	CM	CM	CM	CM	CM	CM	CM	CM	CM	CM	CM	CM	-	-	-	-	-	-	
44499-0089	10	10BC	CS	CS	CM	CS	CS	CM	CM	CM	CM	CS	-	-	-	-	-	-	-	-	-	-	-	-	-	
44499-0090	24	24BD	DS	DS	DM	DM	DM	DS	DS	DS	DS	DM	DS	DS	DS	DS	DS	DS	DS	DS	DS	DS	DM	DM	DS	
44499-0092	04	04BD	DS	DM	DM	DS	-	-	-	-	-	-	-	-	-	-	-	-	-	-	-	-	-	-	-	
44499-0093	04	04BC	CS	CM	CM	CS	-	-	-	-	-	-	-	-	-	-	-	-	-	-	-	-	-	-	-	
44499-0094	18	18BC	CM	CM	CM	CM	CM	CM	CM	CM	CM	CM	CM	CM	CM	CM	CM	CM	CS	CM	-	-	-	-	-	
44499-0095	18	18BC	CM	CM	CM	CM	CM	CM	CM	CM	CM	CM	CS	CM	CM	CM	CM	CM	CM	CM	-	-	-	-	-	
44499-0096	24	24AD	DM	DM	V	DM	DM	V	DM	DM	DM	DM	DM	DM	DM	V	DM	DM	V	DM	DM	DM	DM	DM	DM	
44499-0097	14	14BC	CM	CM	CM	CM	CM	CM	CM	CM	CM	CM	CM	CM	CM	CS	-	-	-	-	-	-	-	-	-	
44499-0099	24	24BC	CM	CM	CM	CM	CM	CM	CM	CM	CM	CM	CM	CM	CM	CM	CM	CM	CM	CM	CM	CM	CM	CM	CS	
44499-0100	24	24BC	CS	CM	CM	CM	CM	CM	CM	CM	CM	CM	CM	CM	CM	CS	CM	CS	CM	CS	CM	CS	CM	CS	CS	
44499-0101	14	14BC	CM	CS	CM	CM	CS	CM	CM	CM	CM	CM	CM	CM	CM	CS	-	-	-	-	-	-	-	-	-	
44499-0102	24	24BC	CM	CM	CS	CS	CS	CS	CS	CS	CS	CS	CM	CM	CM	CM	CS	CS	CS	CS	CS	CS	CS	CM	CM	
44499-0103	24	24AD	DM	DS	DS	DS	DS	DS	DS	DS	DS	DS	DS	DS	DS	DS	DS	DS	DS	DS	DS	DS	DS	DM	DM	
44499-0104	24	24BC	CM	CS	CM	CS	CM	CS	CM	CS	CM	CS	CM	CS	CM	CS	CM	CS	CM	CM	CM	CM	CS	CM	CM	
44499-0105	16	16BC	CM	CS	CS	CS	CS	CS	CS	CS	CS	CS	CS	CS	CS	CS	CM	CS	-	-	-	-	-	-	-	
44499-0106	08	08BC	CS	CS	CM	CS	CS	CS	CM	CS	-	-	-	-	-	-	-	-	-	-	-	-	-	-	-	
44499-0107	24	24AD	DM	DM	DM	DM	DM	DM	DM	DM	DM	DM	DM	DM	DM	DM	DM	DM	DM	DM	DM	DM	DM	DM	DM	
44499-0108	14	14BC	CS	CS	CS	CS	CS	CS	CM	CS	CS	CS	CS	CS	CS	CS	-	-	-	-	-	-	-	-	-	
44499-0109	24	24BC	CM	CS	CS	CM	CS	CS	CS	CS	CS	CS	CS	CM	CS	CS	CM	CS	CS	CS	CS	CS	CS	CS	CS	
44499-0111	06	06BC	CM	CS	CS	CM	CS	CS	-	-	-	-	-	-	-	-	-	-	-	-	-	-	-	-	-	
44499-0112	24	24BC	CS	CM	CM	CS	CS	CS	CS	CS	CS	CS	CS	CS	CM	CM	CS	CS	CS	CS	CS	CS	CS	CS	CS	

CHARACTERISTICS LEGEND:

CIRCUIT SIZE _____

(02-24)

HOUSING MATERIAL _____

A = NYLON 6/6, U.L. 94V-2,
COLOR: NATURAL

B = NYLON 6/6, U.L. 94V-0,
COLOR: NATURAL

TERMINAL PLATING _____

C = SELECT GOLD

D = MATTE TIN OVERALL

* = MIXED TIN AND GOLD

TERMINAL PLATING AND LENGTH CODE

CS = SELECT GOLD, STANDARD LENGTH

DS = MATTE TIN, STANDARD LENGTH

CM = SELECT GOLD, MATE-FIRST/BREAK-LAST (LONGER)

DM = MATTE TIN, MATE-FIRST/BREAK-LAST (LONGER)

V = VOID CIRCUIT

QUALITY SYMBOLS

▽=0

▽=0

▽=0

SEE SHEET 1

EC NO: UCP2018-0545

DRWN:APPELDORN 2017/10/11

CHKD:JBELL 2017/10/11

APPR:FSMITH 2017/10/13

REV: D21

GENERAL TOLERANCES (UNLESS SPECIFIED)

	mm	INCH
4 PLACES ±	---	---
3 PLACES ±	---	±.010
2 PLACES ±	0.25	±.015
1 PLACE ±	0.38	±---
0 PLACE ±		±

ANGULAR ±1/2°

DRAFT WHERE APPLICABLE MUST REMAIN WITHIN DIMENSIONS

DIMENSION STYLE

IN/MM

DRAWN BY DATE

AFG 1994/09/13

CHECKED BY DATE

RJF 1994/09/13

APPROVED BY DATE

FSMITH 2011/08/03

SCALE 1:1

DESIGN UNITS METRIC

THIRD ANGLE PROJECTION

TITLE

SELECTIVELY-LOADED RT ANGLE DUAL ROW HEADER (MATE-FIRST/BREAK-LAST)

molex

MATERIAL NO. SEE CHART

DOCUMENT NO. SDA-44499-*

SHEET NO. 2 OF 3

THIS DRAWING CONTAINS INFORMATION THAT IS PROPRIETARY TO MOLEX INCORPORATED AND SHOULD NOT BE USED WITHOUT WRITTEN PERMISSION

ITEM NO.	CKT. SIZE	CHARACTERISTIC DESCRIPTION	LETTER INDICATES PIN PLATING AND LENGTH REQUIRED AT EACH CIRCUIT LOCATION, SEE NOTE 2 ON SHEET 1.																							
			1	2	3	4	5	6	7	8	9	10	11	12	13	14	15	16	17	18	19	20	21	22	23	24
44499-0113	24	24BD	DS	V	DS	V	DS	V	DS	V	V	DS	DS	DS	V	DS	V	DS	V	DS	V	V	DS	DS	DS	
44499-0114	14	14BD	DS	V	DS	V	DS	V	DS	DS	V	DS	V	DS	-	-	-	-	-	-	-	-	-	-		
44499-0115	18	18BD	DS	V	V	DS	V	V	DS	DS	DS	DS	V	V	DS	V	V	DS	DS	DS	-	-	-	-		
44499-0116	04	04BD	DS	DS	DM	DM	-	-	-	-	-	-	-	-	-	-	-	-	-	-	-	-	-			
44499-0117	10	10BD	DM	DM	DM	DM	DM	DM	DM	DM	DM	DM	DM	DM	DM	DM	DM	DM	DM	DM	DM	DM	DM	DM		
44499-0118	14	14BD	DM	DM	DM	DM	DM	DM	DM	DM	DM	DM	DM	DM	DM	DM	DM	DM	DM	DM	DM	DM	DM	DM		
44499-0119	14	14BC	CM	CM	CM	CM	CS	CM	CS	CM	CM	CM	CM	CM	CM	CM	CM	CS	-	-	-	-	-	-		
44499-0120	14	14BC	CM	CM	CM	CM	CS	CM	CM	CM	CM	CM	CM	CS	CM	CM	-	-	-	-	-	-	-	-		
44499-0121	10	10BC	CM	CS	CS	CS	CS	CM	CS	CS	CS	CS	-	-	-	-	-	-	-	-	-	-	-	-		
44499-0122	18	18BC	CM	CM	CM	CM	CM	CM	CM	CM	CM	CM	CM	CS	CS	CM	CM	CM	CM	CM	-	-	-	-		
44499-0123	10	10BD	DS	V	DS	V	DS	DS	V	DS	V	DS	-	-	-	-	-	-	-	-	-	-	-	-		
44499-0124	14	14BC	CM	CM	CM	CM	CM	CM	CM	CM	CS	CM	CM	CS	CM	CM	-	-	-	-	-	-	-	-		
44499-0125	14	14BC	CM	CM	CM	CM	CS	CM	CM	CM	CS	CM	CM	CM	CM	CM	-	-	-	-	-	-	-	-		
44499-0126	14	14BC	CM	CM	CM	CM	CS	CM	CM	CM	CM	CM	CS	CS	CM	CM	-	-	-	-	-	-	-	-		
44499-0127	18	18BD	DM	DM	DM	DM	DM	DS	DS	DM	DS	DM	DM	DM	DM	DM	DM	DM	DM	-	-	-	-	-		
44499-0128	14	14BC	CM	CM	CM	CS	CS	CM	CS	CM	CM	CM	CS	CM	CM	CS	-	-	-	-	-	-	-	-		
44499-0129	14	14BD	DM	DM	DM	DS	DS	DM	DS	DM	DM	DM	DS	DS	DM	DS	-	-	-	-	-	-	-	-		
44499-0130	14	14BD	DM	DS	DS	DS	DS	DS	DM	DM	DS	DM	DS	DS	DM	DM	-	-	-	-	-	-	-	-		
44499-0131	14	14BC	CS	CS	CS	CS	CM	CS	CS	CS	CM	CS	CS	CM	CS	CS										

CHARACTERISTICS LEGEND:

CIRCUIT SIZE _____ ** * *

(02-24)

HOUSING MATERIAL _____

A = NYLON 6/6, U.L. 94V-2,
COLOR: NATURAL

B = NYLON 6/6, U.L. 94V-0,
COLOR: NATURAL

TERMINAL PLATING _____

C = SELECT GOLD

D = MATTE TIN OVERALL

* = MIXED TIN AND GOLD

TERMINAL PLATING AND LENGTH CODE

CS = SELECT GOLD, STANDARD LENGTH

DS = MATTE TIN, STANDARD LENGTH

CM = SELECT GOLD, MATE-FIRST/BREAK-LAST (LONGER)

DM = MATTE TIN, MATE-FIRST/BREAK-LAST (LONGER)

V = VOID CIRCUIT

SEE SHEET 1 EC NO: UCP2018-0545 DRWN: BAPPELDORN 2017/10/11 CHKD: JBELL 2017/10/11 APPR: FSMITH 2017/10/13	QUALITY SYMBOLS	GENERAL TOLERANCES (UNLESS SPECIFIED)	DIMENSION STYLE	SCALE	DESIGN UNITS	THIRD ANGLE PROJECTION
	▽=0	mm INCH	IN/MM	1:1	METRIC	
	▽=0	4 PLACES ± --- ± ---	DRAWN BY DATE	TITLE		
	▽=0	3 PLACES ± --- ± .010	AFG 1994/09/13	SELECTIVELY-LOADED RT ANGLE DUAL ROW HEADER (MATE-FIRST/BREAK-LAST)		
	2 PLACES ± 0.25 ± .015	CHECKED BY DATE	molex			
	1 PLACE ± 0.38 ± ---	RJF 1994/09/13	SDA-44499-*			
	0 PLACE ± ±	APPROVED BY DATE	SHEET NO. 3 OF 3			
	ANGULAR ±1/2°	FSMITH 2011/08/03	INCORPORATED AND SHOULD NOT BE USED WITHOUT WRITTEN PERMISSION			
	DRAFT WHERE APPLICABLE MUST REMAIN WITHIN DIMENSIONS	MATERIAL NO.				
		SIZE				