

| | | | | | | |
|---|---------------------------------------|---------------------------|----------------------------|---|---|------------------------|
| REVISED EC NO: J2014-0169 2013/07/25 DRWN: INOUE01 2013/07/29 CHKD: H I J IMA 2013/08/05 APPR: YNOGAWA | GENERAL TOLERANCES (UNLESS SPECIFIED) | | DIMENSION STYLE MM ONLY | SCALE --- | DESIGN UNITS METRIC | THIRD ANGLE PROJECTION |
| | 10 UNDER | ±0.2 | DRAWN BY H. SHIMABUKUR | DATE '04/31/17 | TITLE 1.0 FPC CONN ZIF FOR SMT (ST) WITH TAPE -LEAD FREE- | |
| | 10 OVER 30 UNDER | ±0.25 | CHECKED BY K. TOJO | DATE '04/31/17 | molex DOCUMENT NO. SD-52610-034 SHEET NO. 1 OF 2 | |
| | 30 OVER | ±0.3 | APPROVED BY M. SASAO | DATE '04/31/17 | | |
| ANGULAR | ±3 ° | MATERIAL NO. SEE CHART | | THIS DRAWING CONTAINS INFORMATION THAT IS PROPRIETARY TO MOLEX INCORPORATED AND SHOULD NOT BE USED WITHOUT WRITTEN PERMISSION | | |
| DRAFT WHERE APPLICABLE MUST REMAIN WITHIN DIMENSIONS | | | | | | |

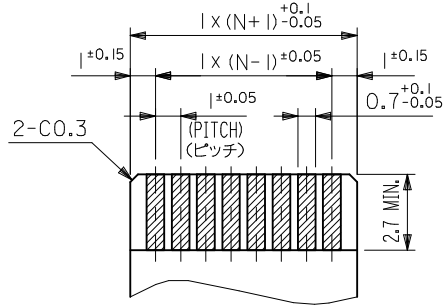

適合FPC推奨寸法
APPLICABLE FPC RECOMMENDED DIM.
仕上がり厚さ(THICKNESS): 0.3 ±0.05

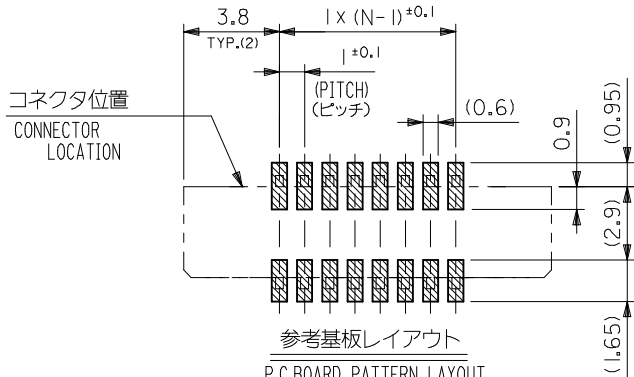

参考基板レイアウト
P.C. BOARD PATTERN LAYOUT
(REFERENCE)

注記 (NOTES):

- 材料 (MATERIAL)
ハウジング (HOUSING): 46NYLON, UL94V-0
アクチュエータ (ACTUATOR): PPS, UL94V-0
ターミナル (TERMINAL): リン青銅, ニッケル下地, 錫-ビスマスメッキ (t0.32)
PHOS-BRO. TIN-BISMUTH OVER NICKEL PLATED (A)
- エンボステープ梱包時は、アクチュエータがロックした状態とする。
IN THE PACKAGE, ACTUATOR OF PART NO. 52610-**-59 SHOULD BE LOCKED.
3. ソルダータール半田付け面のズレ量は、基準面 [F] に対し上方向 0.05 MAX., 下方向 0.15 MAX. とする。
MISALIGNMENT OF SOLDER TAILS FROM [F] UPPER DIRECTION: 0.05 MAX., LOWER DIRECTION: 0.15 MAX.
4. 偶数極に適用。
APPLY FOR EVEN CIRCUIT.
5. 本製品は 52610-**-57 の鉛フリー品である。
THIS PRODUCT IS LEAD FREE OF 52610-**-57

| | | | | | |
|------|-------|------|-----|---------------|------|
| 36.6 | 34.85 | 31.2 | 29 | 52610-3059 | 30 |
| 35.6 | 33.85 | 30.2 | 28 | -2959 | 29 |
| 34.6 | 32.85 | 29.2 | 27 | -2859 | 28 |
| 33.6 | 31.85 | 28.2 | 26 | -2759 | 27 |
| 32.6 | 30.85 | 27.2 | 25 | -2659 | 26 |
| 31.6 | 29.85 | 26.2 | 24 | -2559 | 25 |
| 30.6 | 28.85 | 25.2 | 23 | -2459 | 24 |
| 29.6 | 27.85 | 24.2 | 22 | -2359 | 23 |
| 28.6 | 26.85 | 23.2 | 21 | -2259 | 22 |
| 27.6 | 25.85 | 22.2 | 20 | -2159 | 21 |
| 26.6 | 24.85 | 21.2 | 19 | -2059 | 20 |
| 25.6 | 23.85 | 20.2 | 18 | -1959 | 19 |
| 23.6 | 21.85 | 18.2 | 16 | -1759 | 17 |
| 22.6 | 20.85 | 17.2 | 15 | -1659 | 16 |
| 21.6 | 19.85 | 16.2 | 14 | -1559 | 15 |
| 20.6 | 18.85 | 15.2 | 13 | -1459 | 14 |
| 19.6 | 17.85 | 14.2 | 12 | -1359 | 13 |
| 18.6 | 16.85 | 13.2 | 11 | -1259 | 12 |
| 17.6 | 15.85 | 12.2 | 10 | -1159 | 11 |
| 16.6 | 14.85 | 11.2 | 9 | -1059 | 10 |
| 15.6 | 13.85 | 10.2 | 8 | -0959 | 9 |
| 14.6 | 12.85 | 9.2 | 7 | -0859 | 8 |
| 13.6 | 11.85 | 8.2 | 6 | -0759 | 7 |
| 12.6 | 10.85 | 7.2 | 5 | 52610-0659 | 6 |
| D | (C) | B | (A) | MATERIAL. NO. | CKT. |

| | | | | | | | | | | | |
|---|-------------|---------------------------------------|---|----------------------------|---------------------------|--|------------------------------|--|------------------------|--|--|
| REVISED EC NO: J2014-0169 2013/07/25 DRAWN: NIINOUE01 2013/07/29 CHKD: HIJIMA 2013/08/05 APPR: YNOGAWA | DESCRIPTION | GENERAL TOLERANCES (UNLESS SPECIFIED) | | DIMENSION STYLE MM ONLY | | SCALE --- | DESIGN UNITS METRIC | | THIRD ANGLE PROJECTION | | |
| | | 10 UNDER | ±0.2 | DRAWN BY H. SHIMABUKUR | DATE '04/31/17 | TITLE 1.0 FPC CONN ZIF FOR SMT (ST) WITH TAPE -LEAD FREE- | | | | | |
| | | 10 OVER 30 UNDER | ±0.25 | CHECKED BY K. TOJO | DATE '04/31/17 | | | | | | |
| | | 30 OVER | ±0.3 | APPROVED BY M. SASAO | DATE '04/31/17 | | | | | | |
| REV | | ANGULAR ±3 ° | DRAFT WHERE APPLICABLE MUST REMAIN WITHIN DIMENSIONS | | MATERIAL NO. SEE CHART | | DOCUMENT NO. SD-52610-034 | | SHEET NO. 2 OF 2 | | |
| | | SIZE A3 | THIS DRAWING CONTAINS INFORMATION THAT IS PROPRIETARY TO MOLEX INCORPORATED AND SHOULD NOT BE USED WITHOUT WRITTEN PERMISSION | | | | | | | | |

NOTES

1. 梱包数量：1000個/リール
NUMBER OF CONNECTORS : 1000PCS/REEL
2. リードテープ長さ LEAD TAPE LENGTH
20PCS. MIN. トップテープ接着部 (空エンボス)
TOP TAPE BONDED PART. (EMPTY)
部品挿入部
COMPONENT SUPPLIER
末端部 (空部)
TAIL PART (EMPTY)
40 MIN.
3. トップテープの剥離強度：0.1N ~ 1.3N(10gf ~ 130gf)
(剥離方向は下図参照)
尚、本規格値は出荷時に適用。(但し、輸送時に剥離が発生しないこと。)
PEELING OFF FORCE OF TOP TAPE : 0.1N ~ 1.3N(10gf ~ 130gf)
(PEELING DIRECTION AS SHOWN IN FOLLOWING FIG.)
THIS REQUIREMENT SHOULD BE APPLIED AT SHIPMENT.
PEEL OFF SHOULD NOT BE ALLOWED , DURING TRANSPORTATION.
4. 52610-**-59のアクチュエータはハウジング内に押し下げた状態とする。
詳細寸法については 製品単体図面を参照下さい。
ACTUATOR OF PART NO. 52610-**-59 SHOULD BE LOCKED.
FOR DETAIL OF CONNECTOR DIMENSIONS, PLEASE SEE THE DRAWING OF ITSELF.
5. 材料 (MATERIAL)
キャリアテープ (CARRIER TAPE) : ポリプロピレン (POLYPROPYLENE)
トップテープ (TOPTAPE) : PET , PE , PEF
リール (REEL) : ポリスチレン (PS) <リサイクル材を含む>
POLYSTYRENE (PS) <RECYCLE MATERIAL CONTAINED>
6. 本製品は 52610-**-94 の鉛フリー品である。
THIS PRODUCT IS LEAD FREE OF 52610-**-94
7. 本製品は乾燥剤入り、ハイバリア梱包仕様である。
THIS PRODUCT IS HIGH BARRIER PACKAGE WITH DESICCANT.

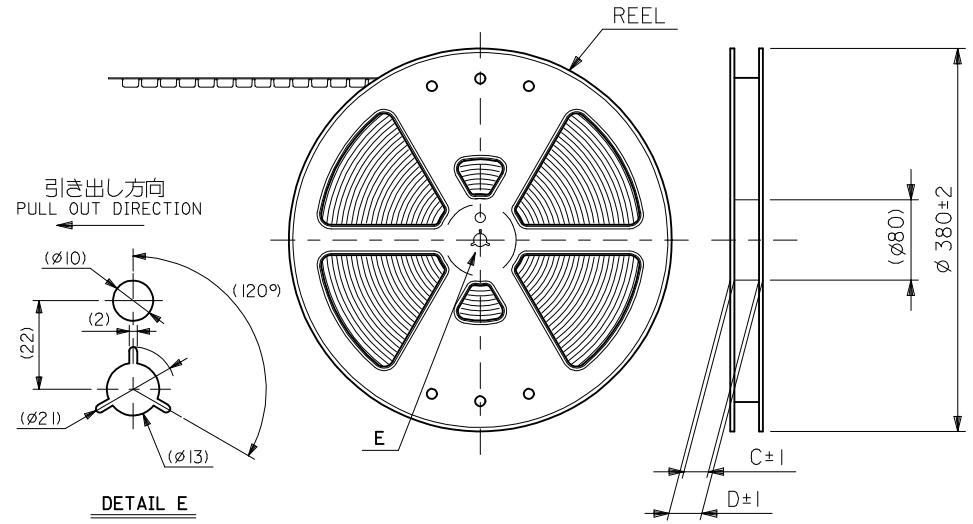
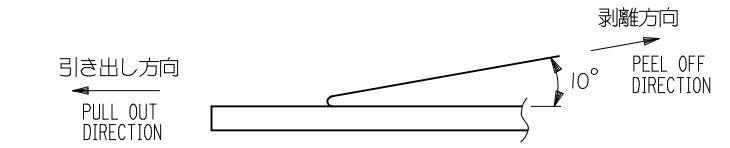
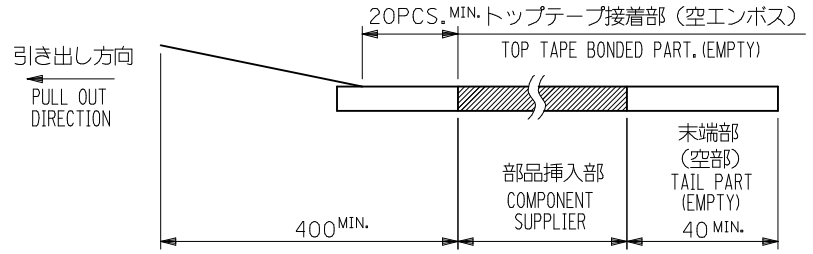

| | | | | | | | |
|---|---------------------------------------|---|----------------------------|------------------------------|--|------------------------|------------------------|
| REVISED EC NO: J2014-0169 DRWN: INOUE01 2013/07/25 CHKD: HIJIMA 2013/07/29 APPR: YNOGAWA 2013/08/05 | GENERAL TOLERANCES (UNLESS SPECIFIED) | | DIMENSION STYLE MM ONLY | | SCALE --- | DESIGN UNITS METRIC | THIRD ANGLE PROJECTION |
| | 10 UNDER | ±0.3 | DRAWN BY H. SHIMABUKUR | DATE 2004/03/17 | TITLE 1.0 FPC CONN SMT ZIF WITH TAPE EMBSTP PKG -LEAD FREE- | | |
| | 10 OVER 30 UNDER | ±0.25 | CHECKED BY K. TOJO | DATE 2004/03/17 | molex SD-52610-035 | | |
| | 30 OVER | ±0.2 | APPROVED BY M. SASAO | DATE 2004/03/17 | | | |
| ANGULAR ±3 ° | | MATERIAL NO. SEE CHART | | DOCUMENT NO. SD-52610-035 | | SHEET NO. 1 OF 5 | |
| DRAFT WHERE APPLICABLE MUST REMAIN WITHIN DIMENSIONS | | THIS DRAWING CONTAINS INFORMATION THAT IS PROPRIETARY TO MOLEX INCORPORATED AND SHOULD NOT BE USED WITHOUT WRITTEN PERMISSION | | | | | |

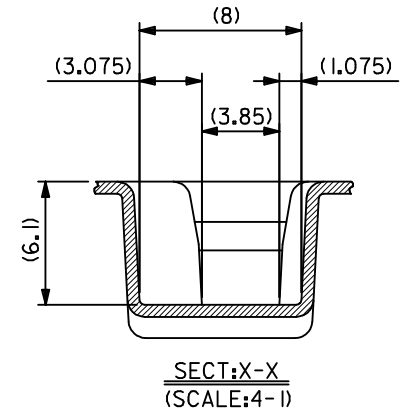
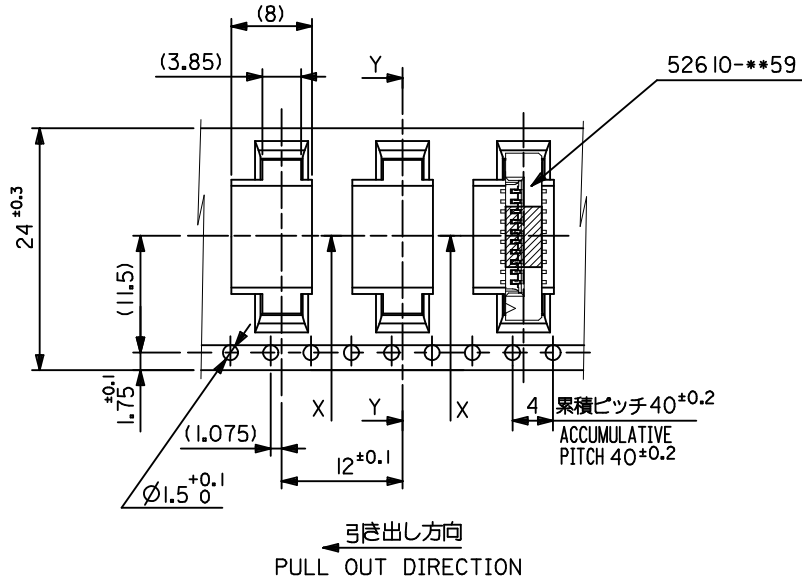
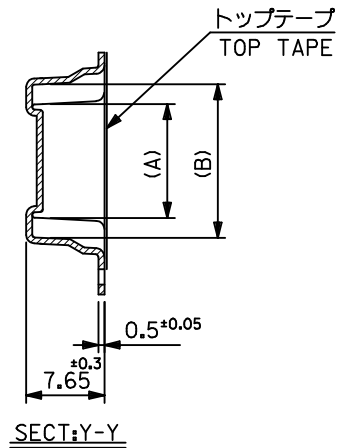

| | | | | | | | |
|-------------|--------------------------------|------|-------|-------|------------|---------------|------------|
| 24 | 29.4 | 25.4 | 15.25 | 11.32 | 52610-1075 | 10 | |
| | | | 14.25 | 10.32 | 52610-0975 | 9 | |
| | | | 13.25 | 9.32 | 52610-0875 | 8 | |
| | | | 12.25 | 8.32 | 52610-0775 | 7 | |
| | | | 11.25 | 7.32 | 52610-0675 | 6 | |
| 52610-***75 | キャリアテープ幅 CARRIER TAPE WIDTH | D | C | (B) | (A) | MATERIAL. NO. | 極数 CKT. |

| | | | | | | | | | | | |
|---|--------------------|---------------------------------------|-------|----------------------------|--|---------------------|--|---|--|---|--|
| REVISED EC NO: J2014-0169 DRWN: INOUE01 2013/07/25 CHKD: HIJIMA 2013/07/29 APPR: YNOGAWA 2013/08/05 | DESCRIPTION REV | GENERAL TOLERANCES (UNLESS SPECIFIED) | | DIMENSION STYLE MM ONLY | | SCALE --- | | DESIGN UNITS METRIC | | THIRD ANGLE PROJECTION | |
| | | 10 UNDER | ±0.3 | DRAWN BY DATE | | TITLE | | 1.0 FPC CONN SMT ZIF WITH TAPE EMBSTP PKG -LEAD FREE- molex DOCUMENT NO. SD-52610-035 SHEET NO. 2 OF 5 | | | |
| | | 10 OVER 30 UNDER | ±0.25 | H. SHIMABUKUR 2004/03/17 | | CHECKED BY DATE | | | | | |
| | | 30 OVER | ±0.2 | K. TOJO 2004/03/17 | | APPROVED BY DATE | | | | | |
| | | ANGULAR ±3 ° | | MATERIAL NO. | | M. SASAO 2004/03/17 | | SEE CHART | | THIS DRAWING CONTAINS INFORMATION THAT IS PROPRIETARY TO MOLEX INCORPORATED AND SHOULD NOT BE USED WITHOUT WRITTEN PERMISSION | |
| DRAFT WHERE APPLICABLE MUST REMAIN WITHIN DIMENSIONS | | SIZE A3 | | | | | | | | | |

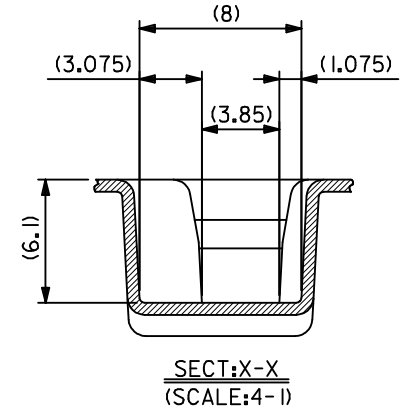
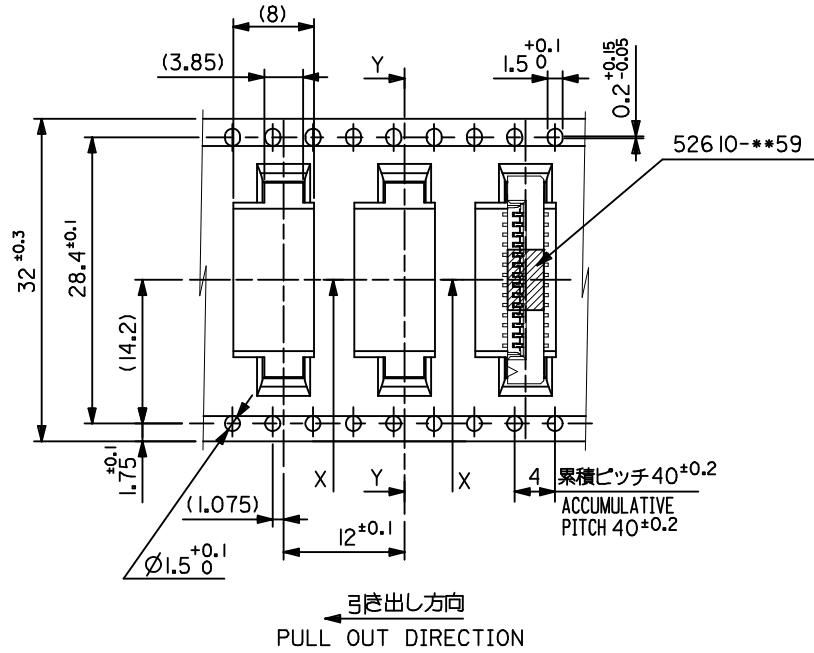
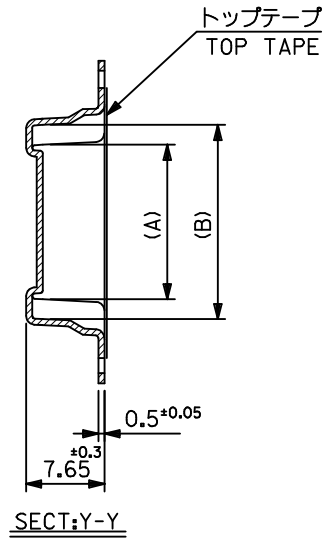

| | | | | | | | | |
|-------------|-----------|--------------------------------|-----|-----|--------------|------------|------------|----|
| 52610-***75 | MODEL NO. | キャリアテープ幅 CARRIER TAPE WIDTH | D | C | 20.25 | 16.32 | 52610-1575 | 15 |
| | | | | | 19.25 | 15.32 | 52610-1475 | 14 |
| | | | | | 18.25 | 14.32 | 52610-1375 | 13 |
| | | | | | 17.25 | 13.32 | 52610-1275 | 12 |
| 32 | 37.4 | 33.4 | (B) | (A) | MATERIAL NO. | 極数 CKT. | | |

| | | | | | | | | | | | | |
|---|-------------|---|--|--------------------------|--|--------------|--|---|--|------------------------|------------------|--|
| REVISED EC NO: J2014-0169 DRWN: INOUE01 2013/07/25 CHKD: HIJIMA 2013/07/29 APPR: YNOGAWA 2013/08/05 | DESCRIPTION | GENERAL TOLERANCES (UNLESS SPECIFIED) | | DIMENSION STYLE | | SCALE | | DESIGN UNITS | | THIRD ANGLE PROJECTION | | |
| | | 10 UNDER ±0.3 | | MM ONLY | | --- | | METRIC | | ◎ □ | | |
| | | 10 OVER 30 UNDER ±0.25 | | DRAWN BY DATE | | TITLE | | 1.0 FPC CONN SMT ZIF WITH TAPE EMBSTP PKG -LEAD FREE- | | | | |
| | | 30 OVER ±0.2 | | H. SHIMABUKUR 2004/03/17 | | | | | | | | |
| ANGULAR ±3 ° | | CHECKED BY DATE | | MATERIAL NO. | | DOCUMENT NO. | | molex SD-52610-035 | | | | |
| DRAFT WHERE APPLICABLE MUST REMAIN WITHIN DIMENSIONS | | K. TOJO 2004/03/17 | | SEE CHART | | | | | | | SHEET NO. 3 OF 5 | |
| APPROVED BY DATE | | THIS DRAWING CONTAINS INFORMATION THAT IS PROPRIETARY TO MOLEX INCORPORATED AND SHOULD NOT BE USED WITHOUT WRITTEN PERMISSION | | | | | | | | | | |
| M. SASAO 2004/03/17 | | | | | | | | | | | | |

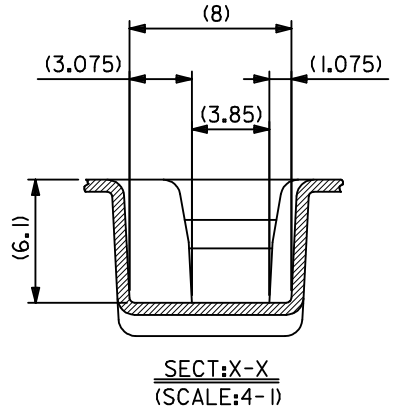
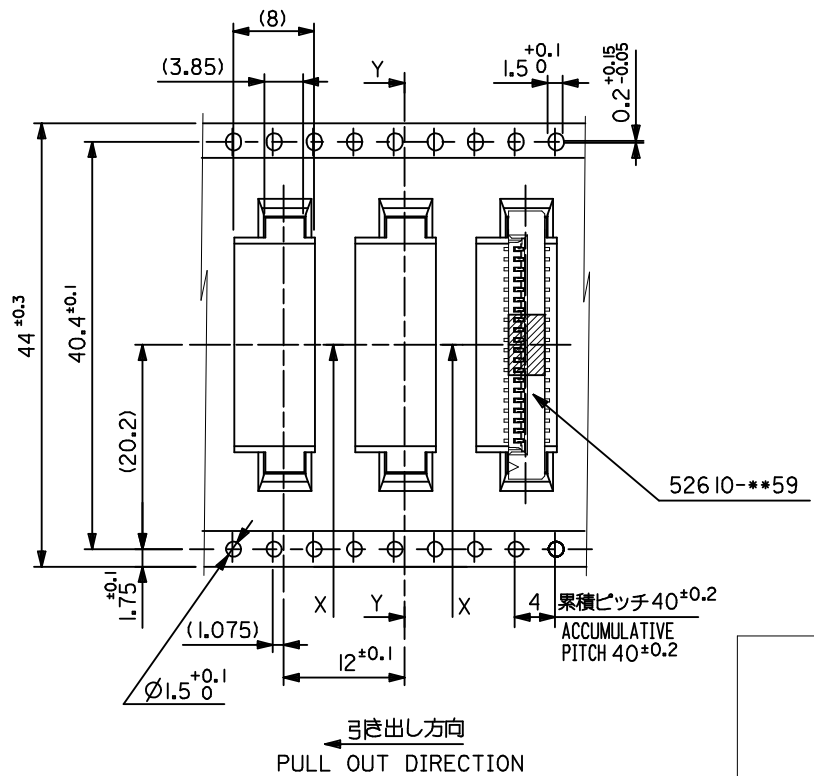
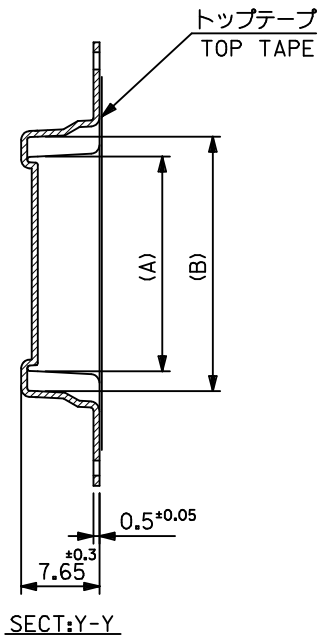

| | | | | | | | |
|-------------|--------------------|---|---|-----|-----|---------------|------|
| 52610-***75 | キャリアテープ幅 | D | C | (B) | (A) | MATERIAL. NO. | 極数 |
| MODEL. NO. | CARRIER TAPE WIDTH | | | | | | CKT. |

| | | | | | | |
|----|------|------|-------|-------|------------|----|
| 44 | 49.4 | 45.4 | 31.25 | 27.32 | 52610-2675 | 26 |
| | | | 30.25 | 26.32 | 52610-2575 | 25 |
| | | | 29.25 | 25.32 | 52610-2475 | 24 |
| | | | 28.25 | 24.32 | 52610-2375 | 23 |
| | | | 27.25 | 23.32 | 52610-2275 | 22 |
| | | | 26.25 | 22.32 | 52610-2175 | 21 |
| | | | 25.25 | 21.32 | 52610-2075 | 20 |
| | | | 24.25 | 20.32 | 52610-1975 | 19 |
| | | | 21.25 | 17.32 | 52610-1675 | 16 |

| | | | | | | | | | | | |
|---|---------------------------------------|---------------------|--------------------------|---|-------|--------------|--|--|------------------------|--|--|
| REVISED EC NO: J2014-0169 DRWN: INOUE01 2013/07/25 CHKD: HIJIMA 2013/07/29 APPR: YNOGAWA 2013/08/05 | GENERAL TOLERANCES (UNLESS SPECIFIED) | | DIMENSION STYLE | | SCALE | | DESIGN UNITS | | THIRD ANGLE PROJECTION | | |
| | | | MM ONLY | | --- | | METRIC | | | | |
| | 10 UNDER | ±0.3 | DRAWN BY DATE | | TITLE | | 1.0 FPC CONN SMT ZIF WITH TAPE EMBOSTP PKG -LEAD FREE- molex SD-52610-035 SHEET NO. 4 OF 5 | | | | |
| | 10 OVER 30 UNDER | ±0.25 | H. SHIMABUKUR 2004/03/17 | | | | | | | | |
| 30 OVER | ±0.2 | K. TOJO 2004/03/17 | | | | | | | | | |
| ANGULAR ±3 ° | | APPROVED BY DATE | | MATERIAL NO. | | DOCUMENT NO. | | | | | |
| DRAFT WHERE APPLICABLE MUST REMAIN WITHIN DIMENSIONS | | M. SASAO 2004/03/17 | | SEE CHART | | SD-52610-035 | | | | | |
| | | SIZE A3 | | THIS DRAWING CONTAINS INFORMATION THAT IS PROPRIETARY TO MOLEX INCORPORATED AND SHOULD NOT BE USED WITHOUT WRITTEN PERMISSION | | | | | | | |

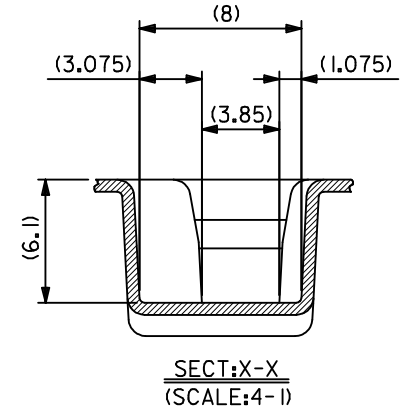
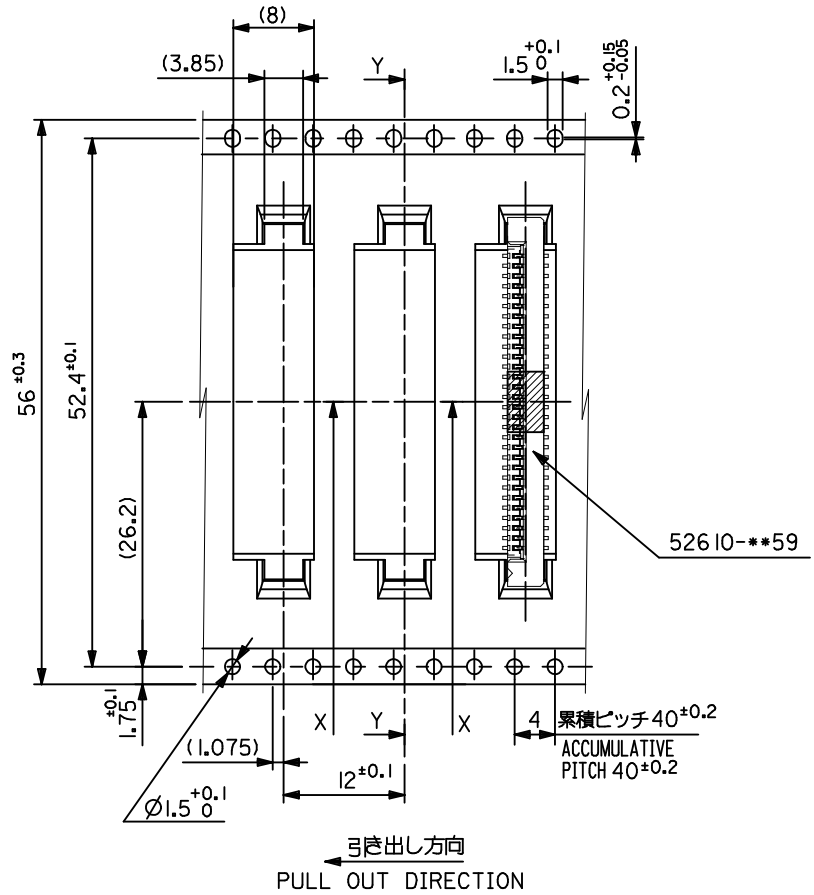
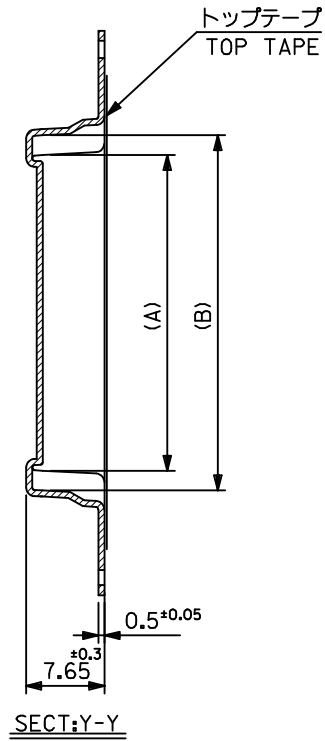

| | | | | | | | |
|-------------|--------------------------------|------|------|-------|-------|---------------|------------|
| 52610-***75 | 56 | 61.4 | 57.4 | 35.25 | 31.32 | 52610-3075 | 30 |
| MODEL.NO. | キャリアテープ幅 CARRIER TAPE WIDTH | D | C | 33.25 | 29.32 | 52610-2875 | 28 |
| | | | | (B) | (A) | MATERIAL. NO. | 極数 CKT. |

| | | | | | | | |
|---|--|---|---|--|--|------------------------|------------------------|
| REVISED EC NO: J2014-0169 DRWN: INOUE01 2013/07/25 CHKD: HIJIMA 2013/07/29 APPR: YNOGAWA 2013/08/05 | GENERAL TOLERANCES (UNLESS SPECIFIED) | | DIMENSION STYLE MM ONLY | | SCALE --- | DESIGN UNITS METRIC | THIRD ANGLE PROJECTION |
| | 10 UNDER | ±0.3 | DRAWN BY DATE H. SHIMABUKUR 2004/03/17 | | TITLE 1.0 FPC CONN SMT ZIF WITH TAPE EMBSTP PKG -LEAD FREE- | | |
| | 10 OVER 30 UNDER | ±0.25 | CHECKED BY DATE K. TOJO 2004/03/17 | | | | |
| | 30 OVER | ±0.2 | APPROVED BY DATE M. SASAO 2004/03/17 | | | | |
| ANGULAR ±3 ° | DRAFT WHERE APPLICABLE MUST REMAIN WITHIN DIMENSIONS | | MATERIAL NO. SEE CHART | | DOCUMENT NO. SD-52610-035 | SHEET NO. 5 OF 5 | |
| | SIZE A3 | THIS DRAWING CONTAINS INFORMATION THAT IS PROPRIETARY TO MOLEX INCORPORATED AND SHOULD NOT BE USED WITHOUT WRITTEN PERMISSION | | | | | |