

Customer Dwg:

MATERIAL: Copper
 PLATING: Electro-Tin
 STUD SIZE: "D" \pm .005

- 10 - .198
- 14 - .265
- 56 - .328
- 38 - .390
- 76 - .453
- 12 - .515
- 58 - .656
- 34 - .781
- 209 = .209
- 413 = .413

VERSAKRIMP

BRAZE SEAM

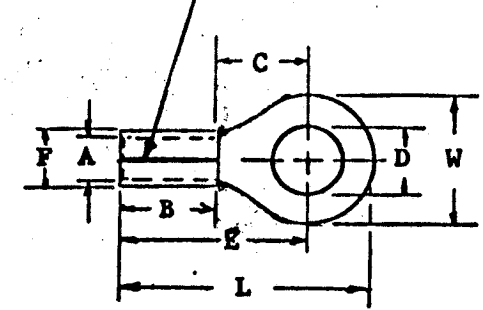

Customer Dimensions

| Part No. | Wire Size | "W" | "C" Min | "E" Max | "B" Min | "L" Max | "A" Min | Stock Thkns. (A) | "F" Max | AVAILABLE STUD SIZE |
|----------|-----------|-----------------------|---------|---------|---------|---------|---------|------------------|---------|-------------------------------------|
| F-366- | #4 | $\frac{.652}{.678}$ | .520 | 1.028 | .425 | 1.385 | .280 | REF. .075 | .470 | 209, 413 10, 14, 56, 38, 76, 12, |
| F-367- | #4 | $\frac{.465}{.485}$ | .520 | 1.028 | .425 | 1.288 | .280 | REF. .075 | .470 | 10, 14, 56 |
| F-369- | #4 | $\frac{.875}{.895}$ | .989 | 1.497 | .425 | 1.970 | .280 | REF. .075 | .470 | 14, 56, 38, 76, 12, 58 |
| F-370- | #4 | $\frac{1.250}{1.270}$ | .989 | 1.497 | .425 | 2.158 | .280 | REF. .075 | .470 | 14, 56, 38, 76, 12, 58, 34 |
| | | | | | | | | | | |
| | | | | | | | | | | |
| | | | | | | | | | | |
| | | | | | | | | | | |
| | | | | | | | | | | |
| | | | | | | | | | | |
| | | | | | | | | | | |
| | | | | | | | | | | |
| | | | | | | | | | | |

For parts to be on tape add "T" at end of part number.



TITLE: "F" RING TONGUE TERMINAL

| DIMENSIONAL TOLERANCE UNLESS OTHERWISE SPECIFIED | | |
|--|-------|-------|
| FRAC. | DEC. | ANG. |
| \pm | \pm | \pm |

| | | |
|----------|-----------------------|--------------|
| REVISION | SCALE: NONE | DATE |
| | DRWN. BY: LEM | 3/2/70 |
| | CHKD. BY: | |
| | APPRD. BY: | |
| A | ETC 50245 11/2 RGM | DRAWING NO.: |