

PART NUMBER DATA								
CIRCUITS	A IN	mm	B IN	mm	C IN	mm	D IN	mm
2	1.58	40.2	1.125	28.58	.83	21.1	.375	9.52
3	1.96	49.7	1.500	38.10	1.21	30.7	.750	19.05
4	2.33	59.2	1.875	47.63	1.58	40.2	1.125	28.58
5	2.71	68.7	2.250	57.15	1.96	49.7	1.500	38.10
6	3.08	78.3	2.625	66.68	2.33	59.2	1.875	47.63
7	3.46	87.8	3.000	76.20	2.71	68.8	2.250	57.15
8	3.83	97.3	3.375	85.73	3.08	78.3	2.625	66.68
9	4.21	106.8	3.750	95.25	3.46	87.8	3.000	76.20
10	4.58	116.4	4.125	104.78	3.83	97.3	3.375	85.73
11	4.96	125.9	4.500	114.30	4.21	106.9	3.750	95.25
12	5.33	135.4	4.875	123.83	4.58	116.4	4.125	104.78
13	5.71	144.9	5.250	133.35	4.96	125.9	4.500	114.30
14	6.08	154.5	5.625	142.88	5.33	135.4	4.875	123.83
15	6.46	164.0	6.000	152.40	5.71	145.0	5.250	133.35
16	6.83	173.5	6.375	161.93	6.08	154.5	5.625	142.88
17	7.21	183.0	6.750	171.45	6.46	164.0	6.000	152.40
18	7.58	192.6	7.125	180.98	6.83	173.5	6.375	161.93
19	7.96	202.1	7.500	190.50	7.21	183.1	6.750	171.45
20	8.33	211.6	7.875	200.03	7.58	192.6	7.125	180.98
21	8.71	221.1	8.250	209.55	7.96	202.1	7.500	190.50
22	9.08	230.7	8.625	219.08	8.33	211.6	7.875	200.03
23	9.46	240.2	9.000	228.60	8.71	221.2	8.250	209.55
24	9.83	249.7	9.375	238.13	9.08	230.7	8.625	219.08
25	10.21	259.2	9.750	247.65	9.46	240.2	9.000	228.60
26	10.58	268.8	10.125	257.18	9.83	249.7	9.375	238.13

- NOTES:
- MATERIAL: SEE TABLE
 - FINISH: SEE TABLE
 - ELECTRICAL SPECS:
MAX VOLTAGE: 300V
MAX CURRENT: 15A (6-32 BINDING HD SCREW STD, -49 & -56 OPT)
MAX CURRENT: 25A (6-32 WIRE CLAMP SCREW -50 OPT)
 - WIRE RANGE: 22 TO 14 AWG FOR STD, -49 & -56 OPT
WIRE RANGE: 22 TO 12 AWG FOR STD, -50 OPT
 - SCREW TIGHTENING TORQUE: 12 IN LBS.
 - WIRE STRIP: 5/16 (8mm)
 - OPERATING TEMP: 110°F
 - PRODUCT SPEC: PS-38710-001
 - PART IS RoHS COMPLIANT
 - XX EQUALS NUMBER OF CIRCUITS

7	XX	SCREW (-56 OPT)	ST. STEEL	PASSIVATED
6	XX	SCREW/CLAMP WASHER (-50 OPT)	STEEL	ZINC PLATED
5	XX	SCREW (-49 OPT)	BRASS	NICKEL PLATED
4	XX	SCREW (STD OPT)	STEEL	ZINC PLATED
3	2	MOUNTING PLATE	BRASS	NICKEL PLATED
2	XX	TERMINAL, WIRE WRAP	BRASS	TIN PLATED
1	1	BARRIER STRIP, INSULATED	PBT	BLACK
ITEM	QTY	DESCRIPTION	MATERIAL	FINISH

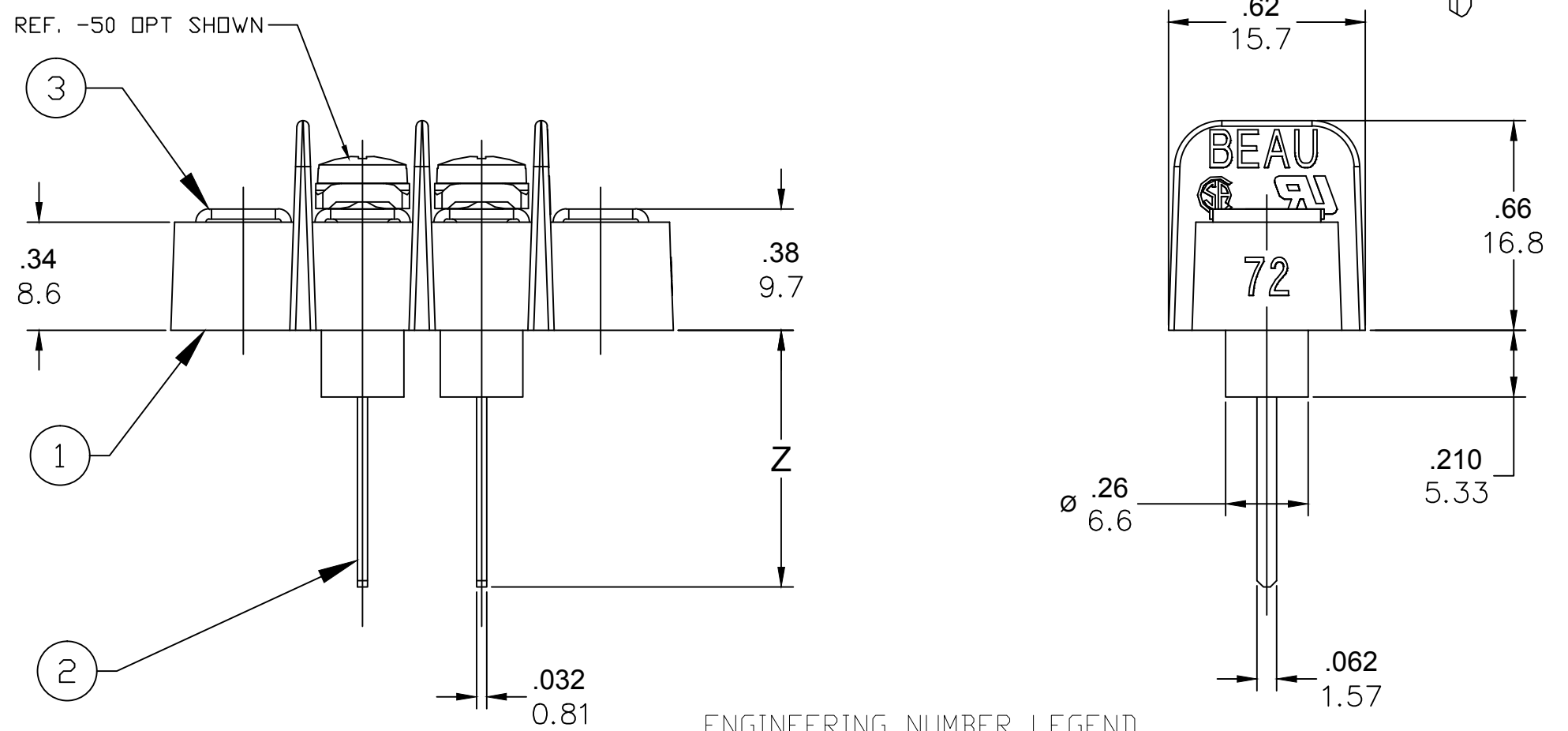
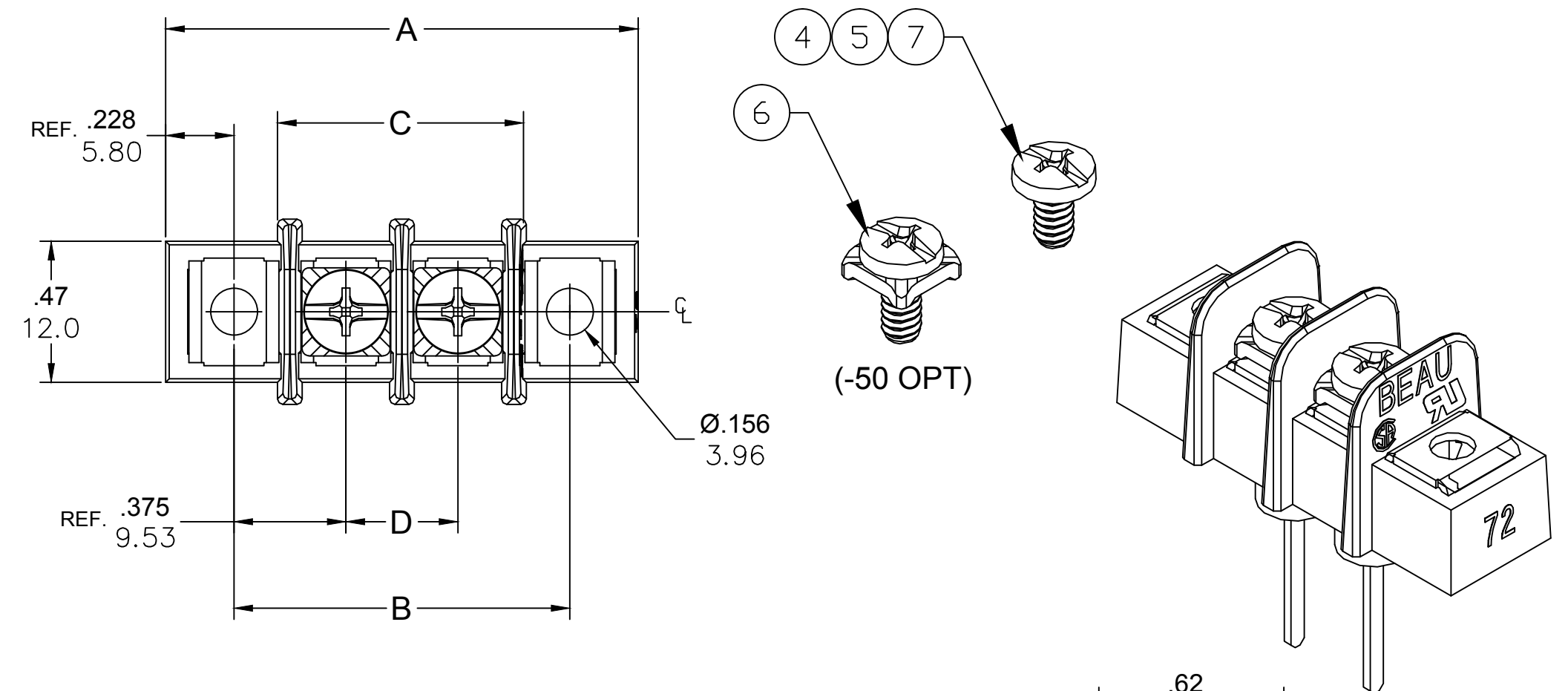

ENGINEERING NUMBER LEGEND

72 3 XX-Y-Z

SERIES
TERMINAL STYLE
NO. OF CIRCUITS

BLANK: .47 STD TAIL LENGTH
-55: .54 TAIL LENGTH
-75: .75 TAIL LENGTH
-81: .81 TAIL LENGTH

SCREW TYPE
BLANK: STD STEEL
-49: BRASS NI PLATE
-50: SCREW W/CLAMP WASHER
-56: ST. STEEL SCREW

RELEASED EC NO: ICG2016-0185 DRWN: RSTONE 2015/08/03 CHKD: B ARDEN APPR: BRUPERT 2015/08/12	QUALITY SYMBOL ▽=0 ▽C=0	GENERAL TOLERANCES (UNLESS SPECIFIED)		DIMENSION STYLE IN/MM		SCALE ---	DESIGN UNITS INCH	THIRD ANGLE PROJECTION		
		4 PLACES	±---	±---	DRAWN BY RSTONE	DATE 2015/08/03	TITLE BARRIER TERMINAL STRIP WIRE WRAP			
		3 PLACES	±---	±.005	CHECKED BY B ARDEN	DATE ---				
		2 PLACES	±0.13	±.01	APPROVED BY BRUPERT	DATE 2015/08/12	MOLEX INCORPORATED			
		1 PLACE	±0.3	±---	MATERIAL NO. ---	DOCUMENT NO. SD-38729-078	SHEET NO. 1 OF 1			
DRAFT WHERE APPLICABLE MUST REMAIN WITHIN DIMENSIONS		ANGULAR ±1°		SIZE C		THIS DRAWING CONTAINS INFORMATION THAT IS PROPRIETARY TO MOLEX INCORPORATED AND SHOULD NOT BE USED WITHOUT WRITTEN PERMISSION				