

REF. -50 OPT. SCREW
(WHERE APPLICABLE)

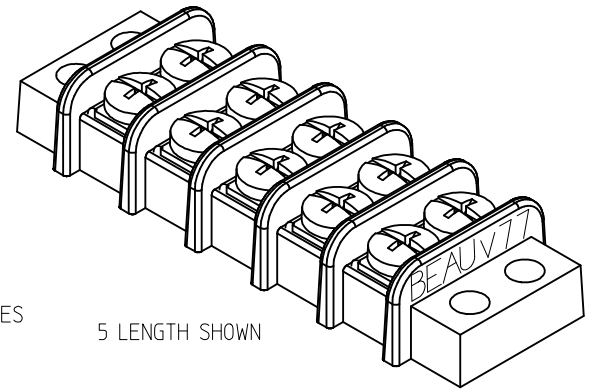
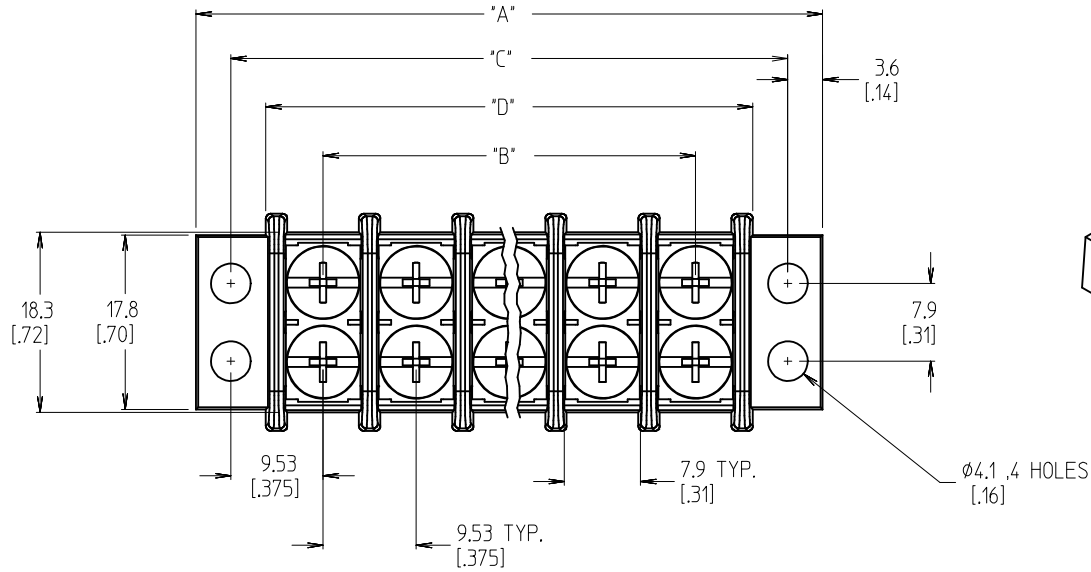

5 LENGTH SHOWN

NOTES:

1. MATERIAL: SEE TABLE
2. FINISHES: SEE TABLE
3. INCH DIMS ARE SHOWN IN BRACKETS [XXX]
4. "XX" REFERS TO THE QUANTITY OF CIRCUITS.
5. -61 OPTION: ONE ROW OF SCREWS NOT SUPPLIED. SCREW QUANTITY = "XX".
6. -49 OPTION: USE ITEM 3 TERMINAL PLATE. ALL OTHERS USE ITEM 2.
7. -58 OPTION: NO SCREWS SUPPLIED.
8. FOR IMPRINTING (-10A OPTION) SEE SD-38120-001.
9. ALL COMPONENTS ARE ROHS COMPLIANT.

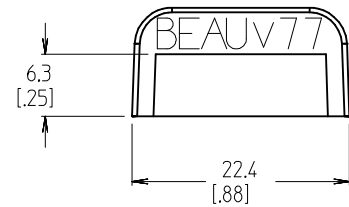
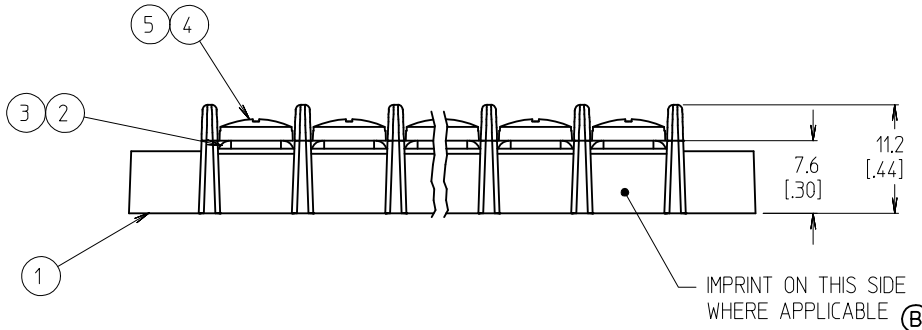

ITEM	QTY.	DESCRIPTION	MATERIAL NO.	ENGINEERING NO.
6	XX*2	SCREW&WASHER, #6-32X.250, PAN, PHIL-SLOT (-50)	STEEL	ZINC W/CHROMATE
5	XX*2	SCREW, #6-32X.250, BHD, PHIL-SLOT (-49)	BRASS	NICKEL PLATE
4	XX*2	SCREW, #6-32X.250, BHD, PHIL-SLOT (STD &-61)	STEEL	ZINC W/CHROMATE
3	XX	TERMINAL PLATE, TIN PLATED (SEE NOTE 6)	BRASS	TIN PLATE
2	XX	TERMINAL PLATE, NICKEL PLATED	BRASS	NICKEL PLATE
1	1	INSULATOR	PBT	BLACK

REMOVE -45 PARTS, ADD -10A
 EC NO: IPG2014-1260
 /DRWN: JENC INAS 2013/10/14
 /CHKD: JMACNEIL 2014/02/07
 /APPR: JMACNEIL 2014/03/10

QUALITY SYMBOLS
 ▽=0
 ▽=0

GENERAL TOLERANCES (UNLESS SPECIFIED)	
mm	INCH
4 PLACES ± ---	± ---
3 PLACES ± ---	± .005
2 PLACES ± 0.13	± .01
1 PLACE ± 0.3	± ---
ANGULAR ± 2 °	

DRAFT WHERE APPLICABLE
 MUST REMAIN WITHIN DIMENSIONS

DIMENSION STYLE	
MM/IN	SCALE
DRAWN BY C. YORK	DATE 2006/08/11
CHECKED BY J. MACNEIL	DATE 2006/08/11
APPROVED BY R. DEROSS	DATE 2006/08/11

SCALE	DESIGN UNITS	THIRD ANGLE PROJECTION
2:1	INCH	☉
9.53 [0.375] DOUBLE ROW LOW PROFILE BTS ASSY		
MOLEX INCORPORATED		SHEET NO. 1 OF 2
DOCUMENT NO. SD-38770-004		