

## FEATURES

- RoHS compliant
- 4 Configurations
- Inductance to 11.7mH
- Up to 50 V $\mu$ s Er
- Industry standard pinout
- 500V<sub>dc</sub> Isolation
- PCB mounting
- UL 94 V-0 package materials
- Toroidal construction
- Fully encapsulated

## DESCRIPTION

The 766 Series is a range of general purpose pulse transformers. Common applications include line coupling, impedance-matching, or isolating. The devices can also be used in small isolated power supplies or as common-mode chokes in filtering applications.

## SELECTION GUIDE<sup>1</sup>

Order Code	Turns Ratio $\pm 2\%$	Min. Primary Inductance	Min. Primary Constant, Er	Max. Leakage Inductance	Max. Interwinding Capacitance	Max. DC Resistance	Max. Isolation Voltage	Pin Connection Style	Mechanical Dimensions
		$\mu$ H	V $\mu$ s	$\mu$ H	pF	$\Omega$			
<b>76600/1C</b>	1:1	1916	17.5	0.60	49	1.50	500	A	1
<b>76600/2C</b>	1:1	492	8.5	0.30	22	0.80			
<b>76600/3C</b>	1:1	219	5.5	0.25	14	0.50			
<b>76600/4C</b>	1:1	50	4.0	0.20	10	0.40			
<b>76601/1C</b>	1:1	1916	17.5	0.60	49	1.50		B	
<b>76601/2C</b>	1:1	492	8.5	0.30	22	0.80			
<b>76601/3C</b>	1:1	219	5.5	0.25	12	0.50			
<b>76601/20C</b>	1:1	20.1	2.5	0.20	5	0.20			
<b>76601/23C</b>	1:1	700	10.5	0.20	35	0.20		C	2
<b>76601/24C</b>	1:1	11.7mH	50.5	0.86	250	1.35			
<b>76602/1C</b>	1:1:1	2060	17.5	0.60	72	1.50		D	
<b>76615/1C</b>	1cr:1cr	3200	45	2.00	52	1.00			
<b>76616/3C</b>	2cr:1cr	4350	23	3.00	35	1.00			

Please note: For additional variants please see 786 series datasheet.

## ABSOLUTE MAXIMUM RATINGS

Operating free air temperature range	0°C to 70°C
Storage temperature range	-60°C to 125°C

## SOLDERING INFORMATION<sup>1</sup>

Peak wave solder temperature	300°C for 10 seconds
Pin finish	Matte tin with nickel pre-plate

<sup>1</sup> For further information, please visit [www.murata-ps.com/rohs](http://www.murata-ps.com/rohs)

All specifications typical at T<sub>A</sub>=25°C.



For full details go to  
[www.murata-ps.com/rohs](http://www.murata-ps.com/rohs)

**PACKAGE SPECIFICATIONS**

**MECHANICAL DIMENSIONS**

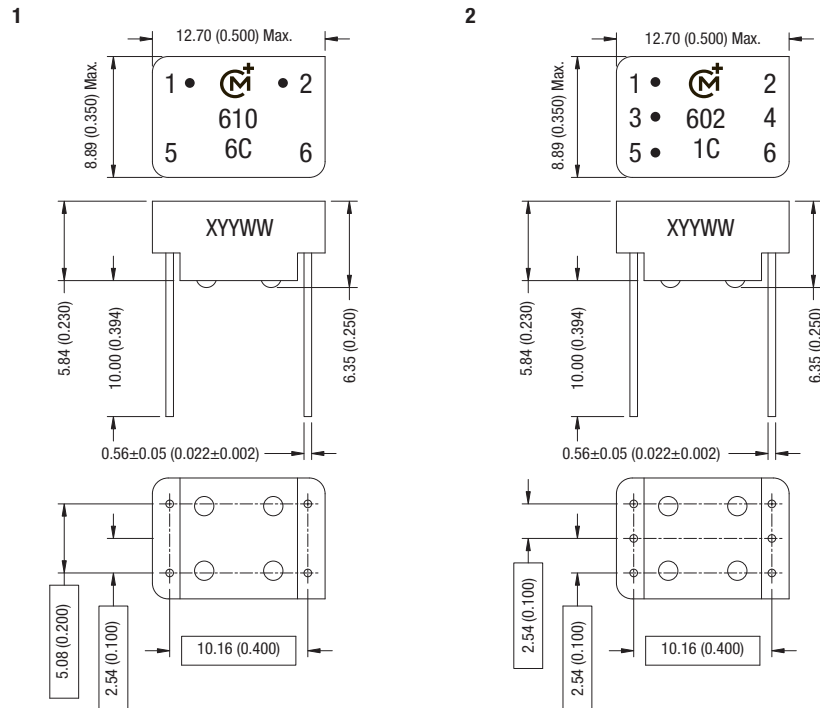

Unless otherwise stated all dimensions in mm (inches)  $\pm 0.25$  (0.01).  
All pins on a 2.54 (0.1) pitch and within  $\pm 0.25$  (0.01) of true position.  
Package Weight: 1.1g Typ.

**RECOMMENDED FOOTPRINT DETAILS**

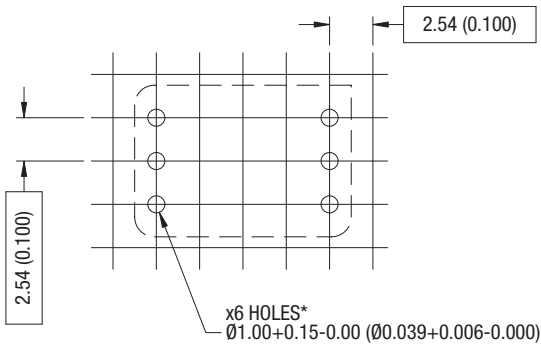

Holes may be omitted for variants with fewer than 6 pins.  
Unless otherwise stated all dimensions in mm (inches)  $\pm 0.25$  (0.01).  
All pins on a 2.54 (0.1) pitch and within  $\pm 0.25$  (0.01) of true position.

**TUBE DIMENSIONS**

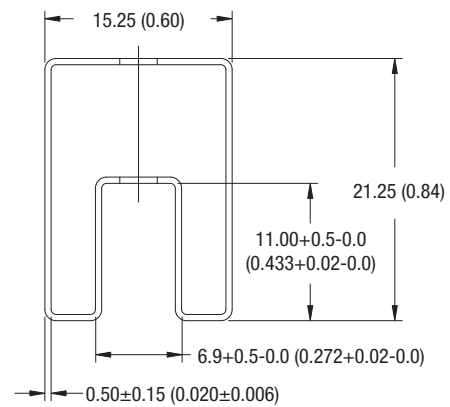

Tube length:  $520 \pm 2.0$  (20.47  $\pm$  0.08)  
Unless otherwise stated all dimensions in mm (inches)  $\pm 0.55$  (0.022).

**PACKAGE SPECIFICATIONS (continued)**

**PIN CONNECTION STYLE - 6 PIN DIP (TOP VIEW)**

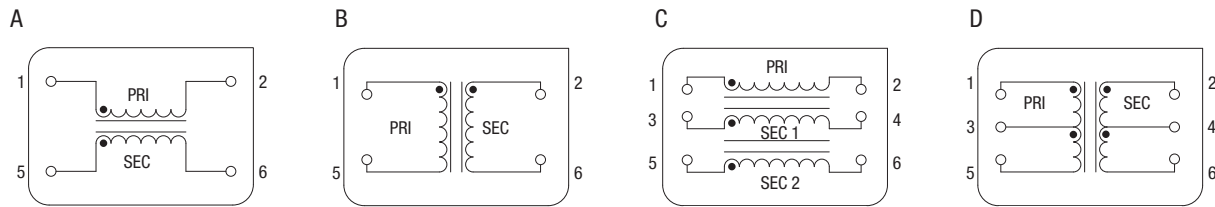

**TECHNICAL NOTES**

**ISOLATION VOLTAGE**

'Hi Pot Test', 'Flash Tested', 'Withstand Voltage', 'Proof Voltage', 'Dielectric Withstand Voltage' & 'Isolation Test Voltage' are all terms that relate to the same thing, a test voltage, applied for a specified time, across a component designed to provide electrical isolation, to verify the integrity of that isolation.

All products in this series are 100% production tested at their stated isolation voltage.

A question commonly asked is, "What is the continuous voltage that can be applied across the part in normal operation?"

For a part holding no specific agency approvals both input and output should normally be maintained within SELV limits i.e. less than 42.4V peak, or 60VDC. The isolation test voltage represents a measure of immunity to transient voltages and the part should never be used as an element of a safety isolation system. The part could be expected to function correctly with several hundred volts offset applied continuously across the isolation barrier; but then the circuitry on both sides of the barrier must be regarded as operating at an unsafe voltage and further isolation/insulation systems must form a barrier between these circuits and any user-accessible circuitry according to safety standard requirements.

**REPEATED HIGH-VOLTAGE ISOLATION TESTING**

It is well known that repeated high-voltage isolation testing of a barrier component can actually degrade isolation capability, to a lesser or greater degree depending on materials, construction and environment. This series has toroidal isolation transformers, with no additional insulation between primary and secondary windings of enameled wire. While parts can be expected to withstand several times the stated test voltage, the isolation capability does depend on the wire insulation. Any material, including this enamel (typically polyurethane) is susceptible to eventual chemical degradation when subject to very high applied voltages thus implying that the number of tests should be strictly limited. We therefore strongly advise against repeated high voltage isolation testing, but if it is absolutely required, that the voltage be reduced by 20% from specified test voltage.

This consideration equally applies to agency recognized parts rated for better than functional isolation where the wire enamel insulation is always supplemented by a further insulation system of physical spacing or barriers.