

LOW DROPOUT VOLTAGE REGULATOR

■ GENERAL DISCRIPTION

NJU7747/48 is a low dropout voltage regulator with ON/OFF control.

Advanced CMOS technology achieves ultra low quiescent current.

SC-82AB package and 0.1 μ F small output capacitor make the NJU7747/48 suitable for space conscious applications.

NJU7748 features shunt switch which improves turn off response of output voltage when ON/OFF control is used.

■ PACKAGE OUTLINE



NJU7747/48F4

■ FEATURES

- Ultra Low quiescent Current $I_q=1.5\mu A$ typ. ($I_o=0mA$)
- Output capacitor with 0.1 μF ceramic capacitor
- Output Current $I_o(max.)=100mA$
- High Precision Output $V_o\pm 1.0\%$
- Low Dropout Voltage 0.17V typ. ($I_o=40mA$, $V_o=3V$ version)
- With ON/OFF Control (Active High)
- With Output Shunt Switch Only NJU7748
- Internal Short Circuit Current Limit
- CMOS Technology
- Package Outline SC-82AB

■ PIN CONFIGURATION

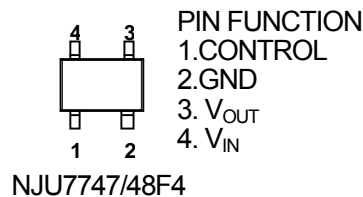

■ EQUIVALENT CIRCUIT

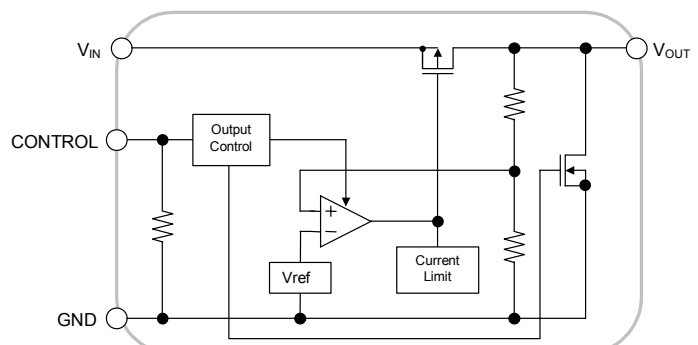
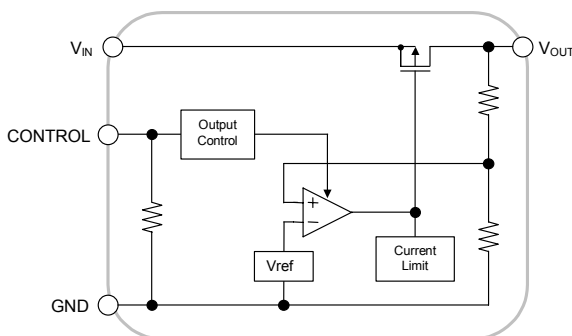

NJU7747/48

■ OUTPUT VOLTAGE RANK LIST

DEVICE NAME	V _{OUT}	DEVICE NAME	V _{OUT}	DEVICE NAME	V _{OUT}
NJU774*F4-15	1.5V	NJU774*F4-28	2.8V	NJU774*F4-04	4.0V
NJU774*F4-18	1.8V	NJU774*F4-29	2.9V	NJU774*F4-45	4.5V
NJU774*F4-19	1.9V	NJU774*F4-03	3.0V	NJU774*F4-05	5.0V
NJU774*F4-02	2.0V	NJU774*F4-31	3.1V		
NJU774*F4-25	2.5V	NJU774*F4-33	3.3V		
NJU774*F4-27	2.7V	NJU774*F4-37	3.7V		

■ ABSOLUTE MAXIMUM RATINGS (Ta=25°C)

PARAMETER	SYMBOL	RATINGS	UNIT
Input Voltage	V _{IN}	+10	V
Control Voltage	V _{CONT}	+10(*1)	V
Power Dissipation	P _D	250(*2)	mW
Operating Temperature	T _{opr}	-40 ~ +85	°C
Storage Temperature	T _{stg}	-40 ~ +125	°C
Output Sink Current at OFF-state(*3)	I _o	10	mA

(*1) When input voltage is less than +10V, the absolute maximum control voltage is equal to the input voltage.

(*2) Mounted on glass epoxy board based on EIA/JEDEC. (114.3x76.2x1.6mm: 2Layers)

(*3): This maximum rating is applied to NJU7748.

■ ELECTRICAL CHARACTERISTICS (V_{IN}=V_O+1V, C_{IN}=0.1μF, C_O=0.1μF, Ta=25°C)

PARAMETER	SYMBOL	TEST CONDITION	MIN.	TYP.	MAX.	UNIT	
Output Voltage	V _O	I _o =30mA	-1.0%	-	+1.0%	V	
Input Voltage	V _{IN}		-	-	6	V	
Quiescent Current	I _q	I _o =0mA, V _{CONT} =V _{IN} , Except I _{CONT}	-	1.5	3.5	μA	
Quiescent Current at Control OFF	I _{q(OFF)}	V _{CONT} =0V	-	0.1	1	μA	
Output Current	I _o	V _O =0.3V	100	-	-	mA	
Short Circuit Limit	I _{LIM}	V _O =0V	-	25	-	mA	
Line Regulation	ΔV _O /ΔV _{IN}	V _{IN} = V _O +1V~V _O +6.0V(V _O <3.0V) V _{IN} = V _O +1V~9.0V(V _O ≥3.0V), I _o =30mA	-	-	0.30	%/V	
Load Regulation	ΔV _O /ΔV _O	I _o =0~100mA	-	-	0.15	%/mA	
Dropout Voltage	ΔV _{I-O}	I _o =40mA	1.5V≤V _O ≤2.0V	-	0.19	0.60	V
			2.0V≤V _O ≤2.4V	-	0.19	0.29	V
		I _o =60mA	2.5V≤V _O ≤2.7V	-	0.18	0.27	V
			2.8V≤V _O ≤3.3V	-	0.17	0.26	V
			3.4V≤V _O ≤5.0V	-	0.16	0.24	V
Average Temperature Coefficient of Output Voltage	ΔV _O /ΔTa	Ta=0~85°C, I _o =10mA	-	±100	-	ppm/°C	
Pull-down Resistance	R _{CONT}		2	5	10	MΩ	
Control Voltage for ON-State	V _{CONT(ON)}		1.6	-	V _{IN}	V	
Control Voltage for OFF-State	V _{CONT(OFF)}		0	-	0.3	V	
Pull-down Resistance at OFF-state(*4)	R _{O(OFF)}	V _{CONT} =0V (V _O =3.0V Version)	-	300	-	Ω	

(*4) This electrical characteristics is applied to NJU7748.

The above specification is a common specification for all voltages.

Therefore, it may be different from the individual specification for a specific output Voltage.

POWER DISSIPATION vs. AMBIENT TEMPERATURE

NJU7747/48F4 Power Dissipation
($T_{opr} = -40 \sim +85$, $T_j = 125$)

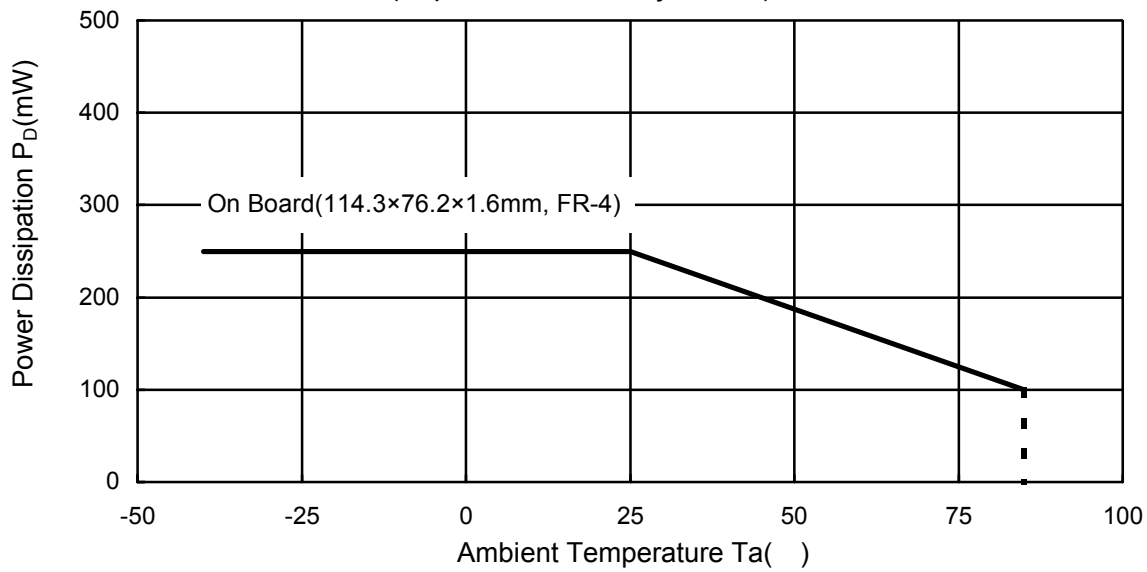

TEST CIRCUIT

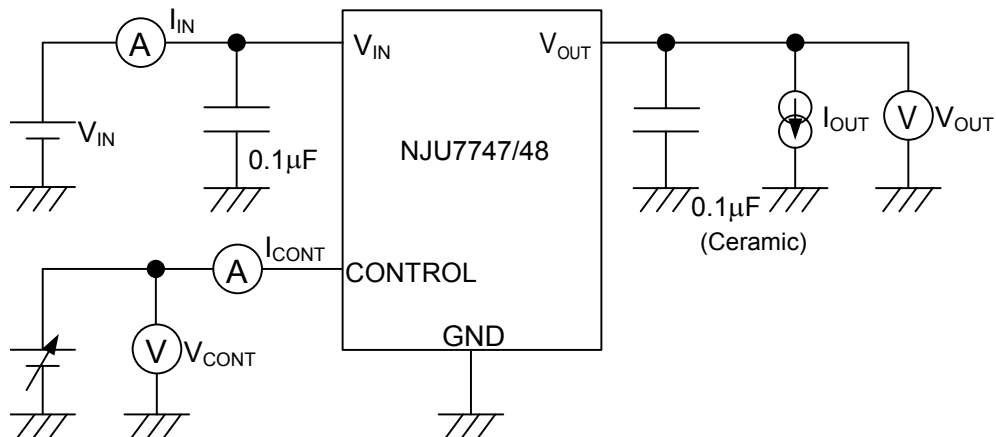

NJU7747/48

■ TYPICAL APPLICATION

① In case that ON/OFF Control is not required:

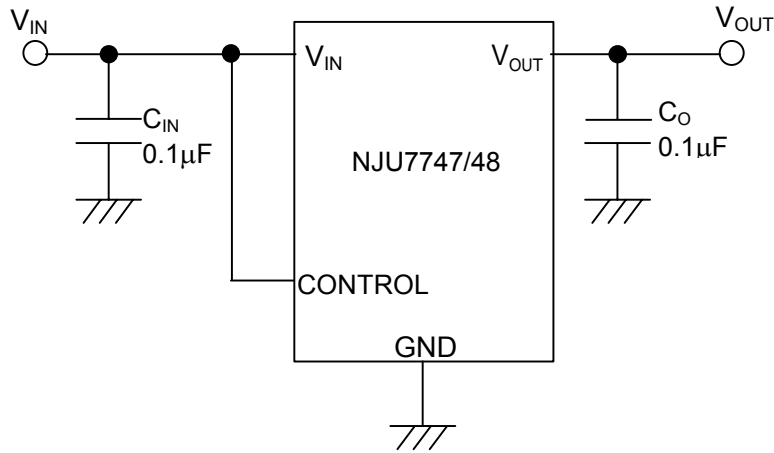

Connect control terminal to V_{IN} terminal.

② In use of ON/OFF Control

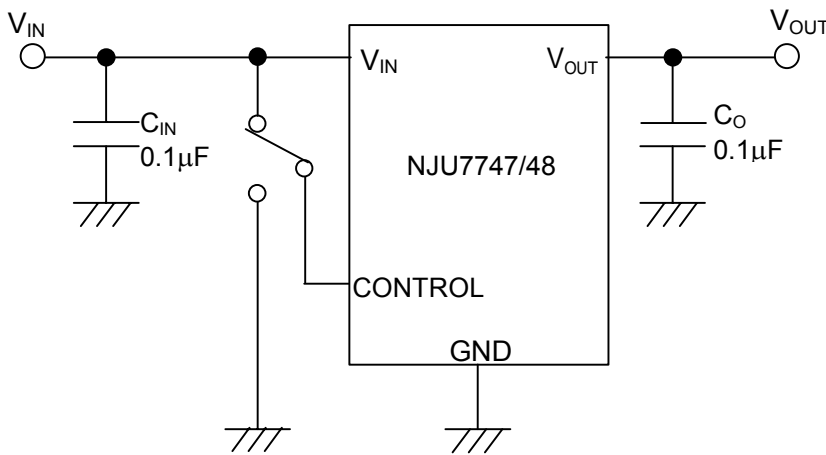

State of control terminal:

- "H" → output is enabled.
- "L" or "open" → output is disabled.

TYPICAL CHARACTERISTICS

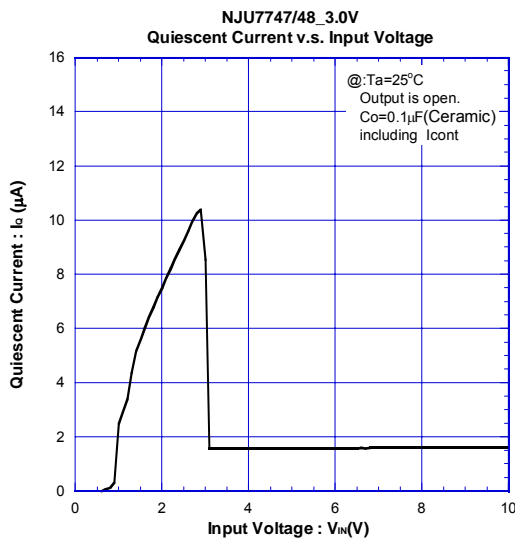
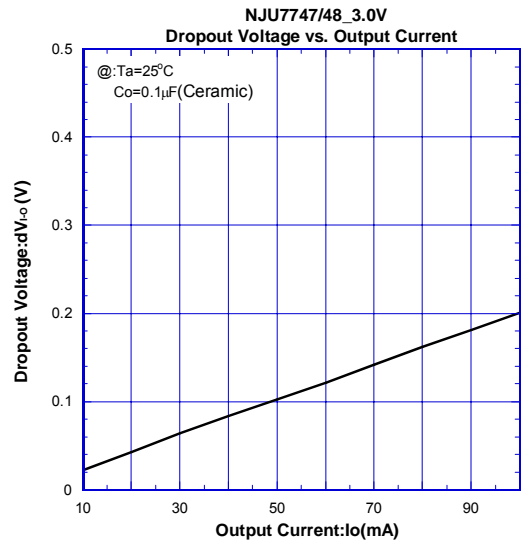
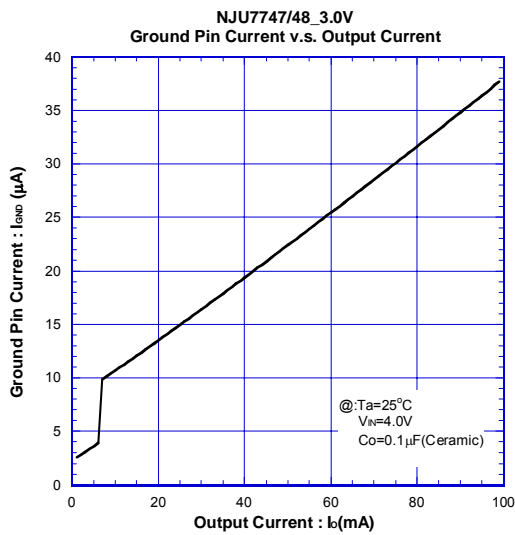
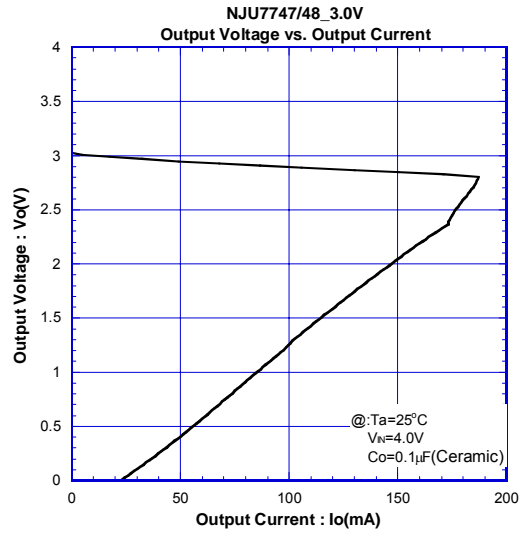
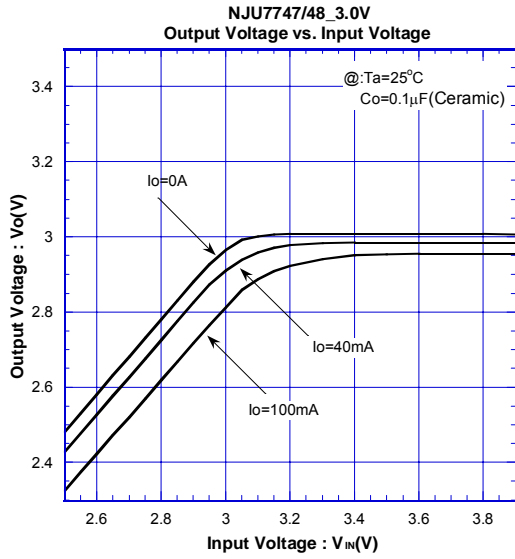

NJU7747/48

TYPICAL CHARACTERISTICS

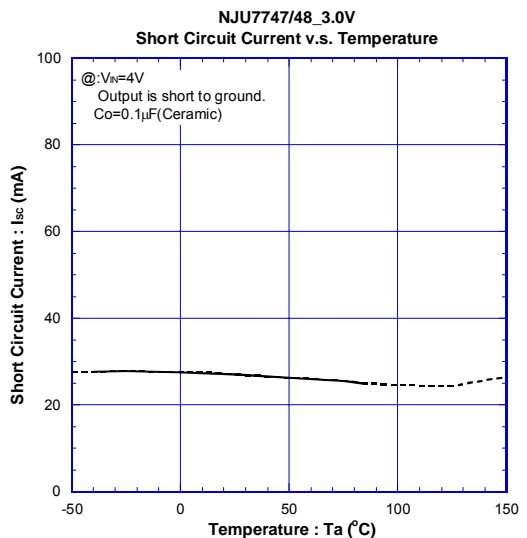
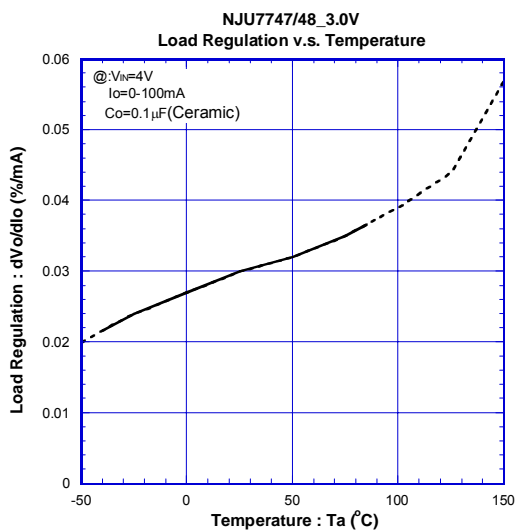
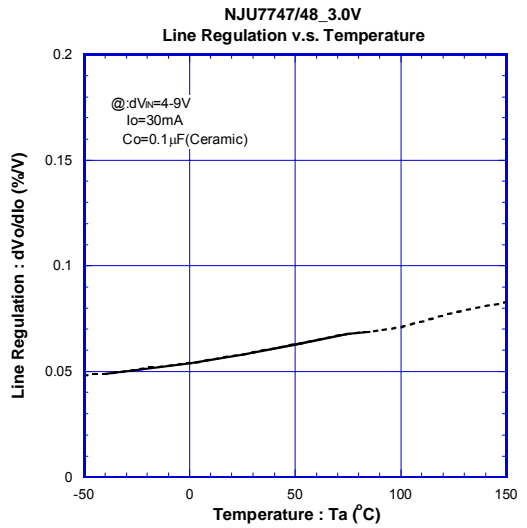
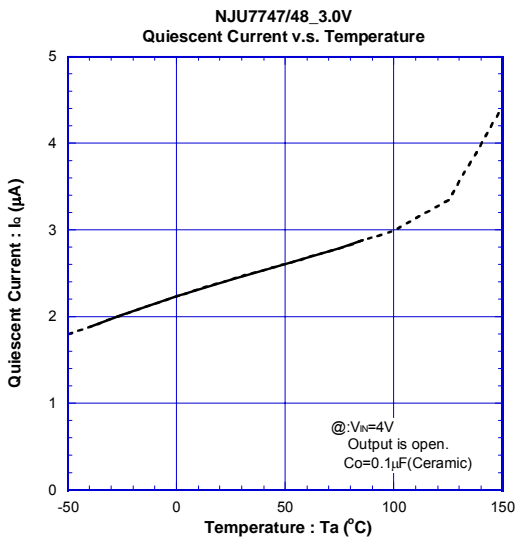
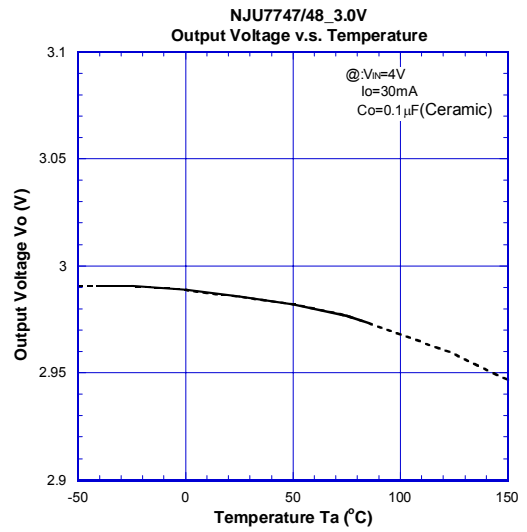
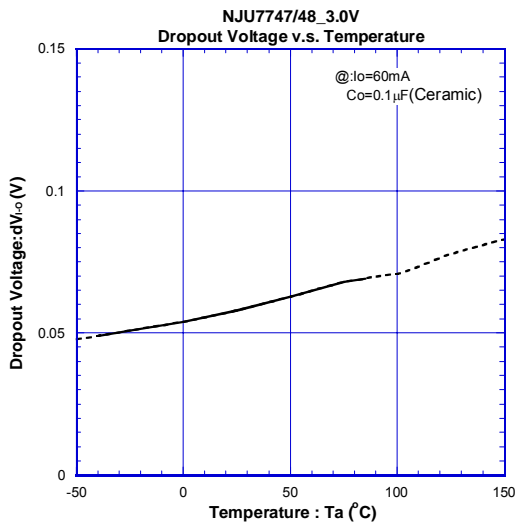

[CAUTION]

The specifications on this databook are only given for information, without any guarantee as regards either mistakes or omissions. The application circuits in this databook are described only to show representative usages of the product and not intended for the guarantee or permission of any right including the industrial rights.