



# LPC3220/30/40/50

16/32-bit ARM microcontrollers; hardware floating-point coprocessor, USB On-The-Go, and EMC memory interface

Rev. 2.1 — 24 June 2014

Product data sheet

## 1. General description

---

The LPC3220/30/40/50 embedded microcontrollers were designed for low power, high performance applications. NXP achieved their performance goals using a 90 nanometer process to implement an ARM926EJ-S CPU core with a vector floating point co-processor and a large set of standard peripherals including USB On-The-Go. The LPC3220/30/40/50 operates at CPU frequencies of up to 266 MHz.

The NXP implementation uses a ARM926EJ-S CPU core with a Harvard architecture, 5-stage pipeline, and an integral Memory Management Unit (MMU). The MMU provides the virtual memory capabilities needed to support the multi-programming demands of modern operating systems. The ARM926EJ-S also has a hardware based set of DSP instruction extensions, which includes single cycle MAC operations, and hardware based native Jazelle Java Byte-code execution. The NXP implementation has a 32 kB instruction cache and a 32 kB data cache.

For low power consumption, the LPC3220/30/40/50 takes advantage of NXP's advanced technology development to optimize intrinsic power and uses software controlled architectural enhancements to optimize application based power management.

The LPC3220/30/40/50 also includes 256 kB of on-chip static RAM, a NAND flash interface, an Ethernet MAC, an LCD controller that supports STN and TFT panels, and an external bus interface that supports SDR and DDR SDRAM as well as static devices. In addition, the LPC3220/30/40/50 includes a USB 2.0 full-speed interface, seven UARTs, two I<sup>2</sup>C-bus interfaces, two SPI/SSP ports, two I<sup>2</sup>S-bus interfaces, two single output PWMs, a motor control PWM, six general purpose timers with capture inputs and compare outputs, a Secure Digital (SD) interface, and a 10-bit Analog-to-Digital Converter (ADC) with a touch screen sense option.

For additional documentation, see [Section 15 "References"](#).

## 2. Features and benefits

---

- ARM926EJ-S processor, running at CPU clock speeds up to 266 MHz.
- Vector Floating Point (VFP) coprocessor.
- 32 kB instruction cache and 32 kB data cache.
- Up to 256 kB of Internal SRAM (IRAM).
- Selectable boot-up from various external devices: NAND flash, SPI memory, USB, UART, or static memory.



- Multi-layer AHB system that provides a separate bus for each AHB master, including both an instruction and data bus for the CPU, two data busses for the DMA controller, and another bus for the USB controller, one for the LCD, and a final one for the Ethernet MAC. There are no arbitration delays in the system unless two masters attempt to access the same slave at the same time.
- External memory controller for DDR and SDR SDRAM as well as for static devices.
- Two NAND flash controllers: One for single-level NAND flash devices and the other for multi-level NAND flash devices.
- Master Interrupt Controller (MIC) and two Slave Interrupt Controllers (SIC), supporting 74 interrupt sources.
- Eight channel General Purpose DMA (GPDMA) controller on the AHB that can be used with the SD card port, the high-speed UARTs, I<sup>2</sup>S-bus interfaces, and SPI interfaces, as well as memory-to-memory transfers.
- Serial interfaces:
  - ◆ 10/100 Ethernet MAC with dedicated DMA Controller.
  - ◆ USB interface supporting either device, host (OHCI compliant), or On-The-Go (OTG) with an integral DMA controller and dedicated PLL to generate the required 48 MHz USB clock.
  - ◆ Four standard UARTs with fractional baud rate generation and 64 byte FIFOs. One of the standard UARTs supports IrDA.
  - ◆ Three additional high-speed UARTs intended for on-board communications that support baud rates up to 921 600 when using a 13 MHz main oscillator. All high-speed UARTs provide 64 byte FIFOs.
  - ◆ Two SPI controllers.
  - ◆ Two SSP controllers.
  - ◆ Two I<sup>2</sup>C-bus interfaces with standard open-drain pins. The I<sup>2</sup>C-bus interfaces support single master, slave, and multi-master I<sup>2</sup>C-bus configurations.
  - ◆ Two I<sup>2</sup>S-bus interfaces, each with separate input and output channels. Each channel can be operated independently on three pins, or both input and output channels can be used with only four pins and a shared clock.
- Additional peripherals:
  - ◆ LCD controller supporting both STN and TFT panels, with dedicated DMA controller. Programmable display resolution up to 1024 × 768.
  - ◆ Secure Digital (SD) memory card interface, which conforms to the *SD Memory Card Specification Version 1.01*.
  - ◆ General Purpose (GP) input, output, and I/O pins. Includes 12 GP input pins, 24 GP output pins, and 51 GP I/O pins.
  - ◆ 10-bit, 400 kHz Analog-to-Digital Converter (ADC) with input multiplexing from three pins. Optionally, the ADC can operate as a touch screen controller.
  - ◆ Real-Time Clock (RTC) with separate power pin and dedicated 32 kHz oscillator. NXP implemented the RTC in an independent on-chip power domain so it can remain active while the rest of the chip is not powered. The RTC also includes a 32-byte scratch pad memory.
  - ◆ 32-bit general purpose high-speed timer with a 16-bit pre-scaler. This timer includes one external capture input pin and a capture connection to the RTC clock. Interrupts may be generated using three match registers.

- ◆ Six enhanced timer/counters which are architecturally identical except for the peripheral base address. Two capture inputs and two match outputs are pinned out to four timers. Timer 1 brings out a third match output, timers 2 and 3 bring out all four match outputs, timer 4 has one match output, and timer 5 has no inputs or outputs.
- ◆ 32-bit millisecond timer driven from the RTC clock. This timer can generate interrupts using two match registers.
- ◆ WatchDog timer clocked by the peripheral clock.
- ◆ Two single-output PWM blocks.
- ◆ Motor control PWM.
- ◆ Keyboard scanner function allows automatic scanning of an up to 8 × 8 key matrix.
- ◆ Up to 18 external interrupts.
- Standard ARM test/debug interface for compatibility with existing tools.
- Emulation Trace Buffer (ETB) with 2048 × 24 bit RAM allows trace via JTAG.
- Stop mode saves power while allowing many peripheral functions to restart CPU activity.
- On-chip crystal oscillator.
- An on-chip PLL allows CPU operation up to the maximum CPU rate without the requirement for a high frequency crystal. Another PLL allows operation from the 32 kHz RTC clock rather than the external crystal.
- Boundary scan for simplified board testing.
- User-accessible unique serial ID number for each chip.
- TFBGA296 package with a 15 mm × 15 mm × 0.7 mm body.

### 3. Applications

---

- Consumer
- Medical
- Industrial
- Network control

## 4. Ordering information

Table 1. Ordering information

Type number <sup>[1]</sup>	Package		
	Name	Description	Version
LPC3220FET296/01 <sup>[2]</sup>	TFBGA296	plastic thin fine-pitch ball grid array package; 296 balls	SOT1048-1
LPC3230FET296/01 <sup>[2]</sup>	TFBGA296	plastic thin fine-pitch ball grid array package; 296 balls	SOT1048-1
LPC3240FET296/01 <sup>[2]</sup>	TFBGA296	plastic thin fine-pitch ball grid array package; 296 balls	SOT1048-1
LPC3250FET296/01 <sup>[2]</sup>	TFBGA296	plastic thin fine-pitch ball grid array package; 296 balls	SOT1048-1

[1] F = -40 °C to +85 °C temperature range. Note that Revision "A" parts with and without the /01 suffix are identical. For example, LPC3220FET296 Revision "A" is identical to LPC3220FET296/01 Revision "A".

[2] Available starting with Revision "A".

### 4.1 Ordering options

Table 2. Part options

Type number	SRAM (kB)	10/100 Ethernet	LCD controller	Temperature range (°C)	Package
LPC3220FET296/01	128	0	0	-40 to +85	TFBGA296
LPC3230FET296/01	256	0	1	-40 to +85	TFBGA296
LPC3240FET296/01	256	1	0	-40 to +85	TFBGA296
LPC3250FET296/01	256	1	1	-40 to +85	TFBGA296

### 5. Block diagram

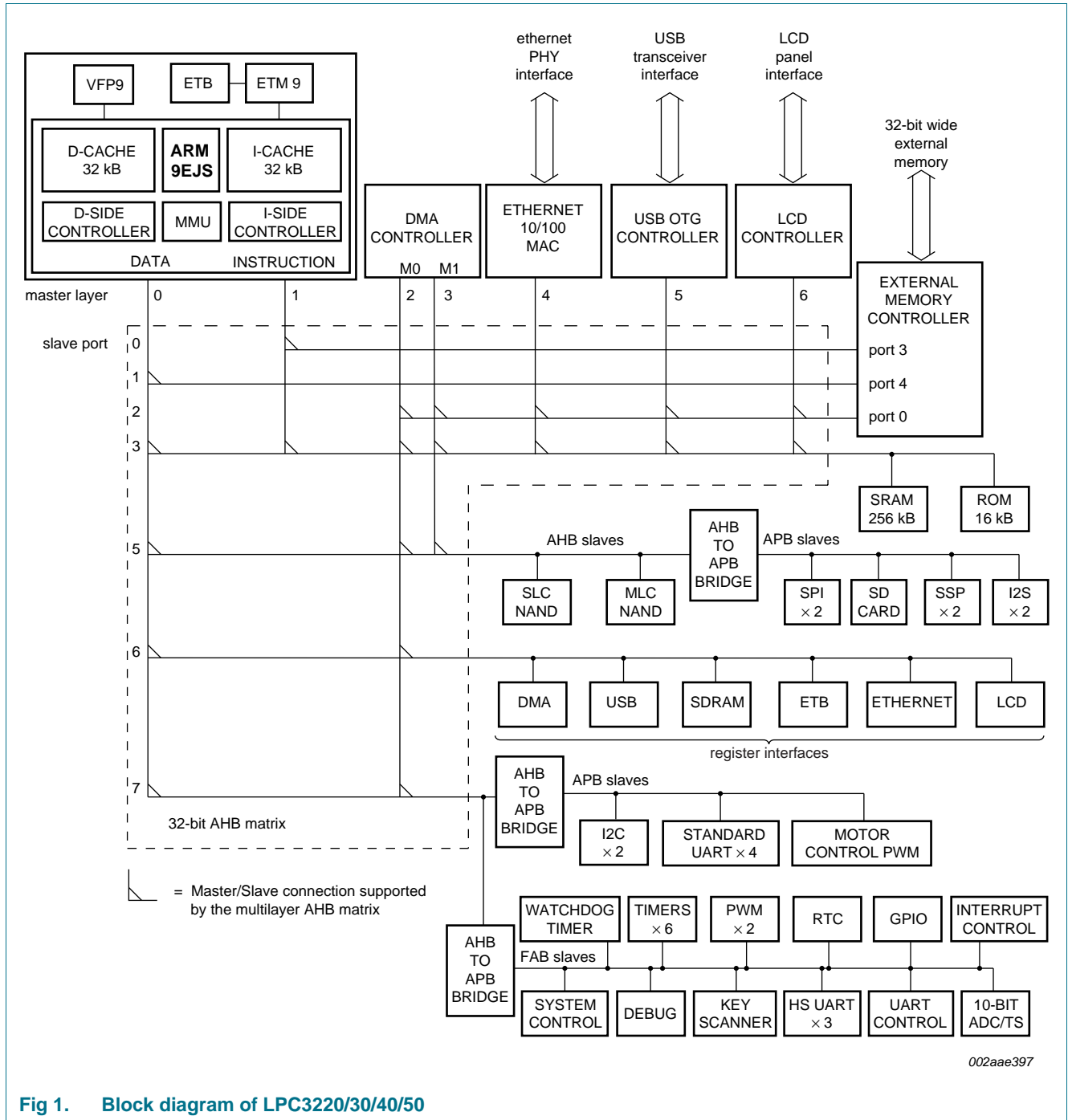

Fig 1. Block diagram of LPC3220/30/40/50

## 6. Pinning information

### 6.1 Pinning

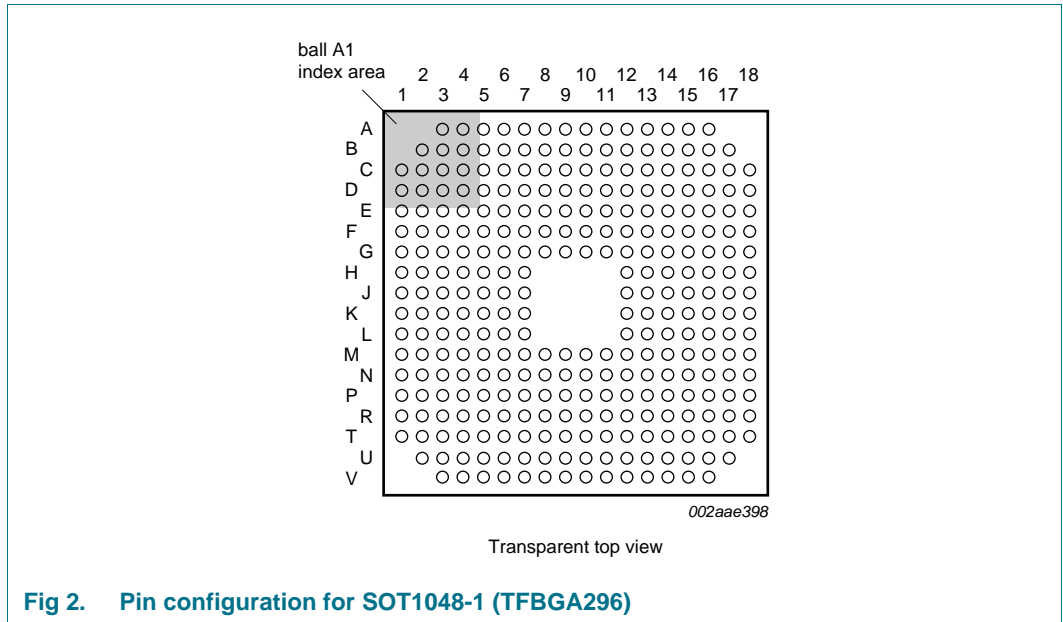

Fig 2. Pin configuration for SOT1048-1 (TFBGA296)

Table 3. Pin allocation table (TFBGA296)

Pin	Symbol	Pin	Symbol	Pin	Symbol
<b>Row A</b>					
				A3	I2C2_SCL
A4	I2S1TX_CLK/MAT3[0]	A5	I2C1_SCL	A6	MS_BS/MAT2[1]
A7	MS_DIO1/MAT0[1]	A8	MS_DIO0/MAT0[0]	A9	SPI2_DATIO/MOSI1/LCDVD[20] <sup>[1]</sup>
A10	SPI2_DATIN/MISO1/LCDVD[21] <sup>[1]</sup> /GPI_27	A11	GPIO_1	A12	GPIO_0
A13	GPO_21/U4_TX/LCDVD[3] <sup>[1]</sup>	A14	GPO_15/MCOA1/LCDDFP <sup>[1]</sup>	A15	GPO_7/LCDVD[2] <sup>[1]</sup>
A16	GPO_6/LCDVD[18] <sup>[1]</sup>				
<b>Row B</b>					
		B2	GPO_20	B3	GPO_5
B4	I2S1TX_WS/CAP3[0]	B5	P0[0]/I2S1RX_CLK	B6	I2C1_SDA
B7	MS_SCLK/MAT2[0]	B8	MS_DIO2/MAT0[2]	B9	SPI1_DATIO/MOSI0/MCI2
B10	SPI2_CLK/SCK1/LCDVD[23] <sup>[1]</sup>	B11	GPIO_4/SSEL1/LCDVD[22] <sup>[1]</sup>	B12	GPO_12/MCOA2/LCDDLE <sup>[1]</sup>
B13	GPO_13/MCOB1/LCDDCLK <sup>[1]</sup>	B14	GPO_2/MAT1[0]/LCDVD[0] <sup>[1]</sup>	B15	GPI_19/U4_RX
B16	GPI_8/KEY_COL6/SPI2_BUSY/ENET_RX_DV <sup>[2]</sup>	B17	n.c.		
<b>Row C</b>					
C1	FLASH_RD	C2	GPO_19	C3	GPO_0/TST_CLK1
C4	USB_ATX_INT	C5	USB_SE0_VM/U5_TX	C6	TST_CLK2
C7	GPI_6/HSTIM_CAP/ENET_RXD2 <sup>[2]</sup>	C8	MS_DIO3/MAT0[3]	C9	SPI1_CLK/SCK0

Table 3. Pin allocation table (TFBGA296)

Pin	Symbol	Pin	Symbol	Pin	Symbol
C10	SPI1_DATIN/MISO0/GPI_25/MCI1	C11	GPIO_3/KEY_ROW7/ENET_MDIO <sup>[2]</sup>	C12	GPO_9/LCDVD <sup>[9]</sup> <sup>[1]</sup>
C13	GPO_8/LCDVD <sup>[8]</sup> <sup>[1]</sup>	C14	GPI_2/CAP2 <sup>[0]</sup> /ENET_RXD3 <sup>[2]</sup>	C15	GPI_1/ <u>SERVICE</u>
C16	GPI_0/I2S1RX_SDA	C17	KEY_ROW4/ENET_TXD0 <sup>[2]</sup>	C18	KEY_ROW5/ENET_TXD1 <sup>[2]</sup>
<b>Row D</b>					
D1	FLASH_RDY	D2	FLASH_ALE	D3	GPO_14
D4	GPO_1	D5	USB_DAT_VP/U5_RX	D6	<u>USB_OE_TP</u>
D7	P0 <sup>[1]</sup> /I2S1RX_WS	D8	GPO_4	D9	GPIO_2/KEY_ROW6/ENET_MDC <sup>[2]</sup>
D10	GPO_16/MCOB0/LCDENAB <sup>[1]</sup> /LCDM <sup>[1]</sup>	D11	GPO_18/MCOA0/LCDLP <sup>[1]</sup>	D12	GPO_3/LCDVD <sup>[1]</sup> <sup>[1]</sup>
D13	GPI_7/CAP4 <sup>[0]</sup> / <u>MCABORT</u>	D14	PWM_OUT1/LCDVD <sup>[16]</sup> <sup>[1]</sup>	D15	PWM_OUT2/INTSTAT/LCDVD <sup>[19]</sup> <sup>[1]</sup>
D16	KEY_ROW3/ENET_TX_EN <sup>[2]</sup>	D17	KEY_COL2/ENET_RX_ER <sup>[2]</sup>	D18	KEY_COL3/ENET_CRSS <sup>[2]</sup>
<b>Row E</b>					
E1	FLASH_IO <sup>[3]</sup>	E2	FLASH_IO <sup>[7]</sup>	E3	<u>FLASH_CE</u>
E4	I2C2_SDA	E5	USB_I2C_SCL	E6	USB_I2C_SDA
E7	I2S1TX_SDA/MAT3 <sup>[1]</sup>	E8	GPO_11	E9	GPIO_5/SSEL0/MCI0
E10	GPO_22/U7_HRTS/LCDVD <sup>[14]</sup> <sup>[1]</sup>	E11	GPO_10/MCOB2/LCDPWR <sup>[1]</sup>	E12	GPI_9/KEY_COL7/ENET_COL <sup>[2]</sup>
E13	GPI_4/SPI1_BUSY	E14	KEY_ROW1/ENET_TXD2 <sup>[2]</sup>	E15	KEY_ROW0/ENET_TX_ER <sup>[2]</sup>
E16	KEY_COL1/ENET_RX_CLK <sup>[2]</sup> /ENET_REF_CLK <sup>[2]</sup>	E17	U7_RX/CAP0 <sup>[0]</sup> /LCDVD <sup>[10]</sup> <sup>[1]</sup> /GPI_23	E18	U7_TX/MAT1 <sup>[1]</sup> /LCDVD <sup>[11]</sup> <sup>[1]</sup>
<b>Row F</b>					
F1	FLASH_IO <sup>[2]</sup>	F2	<u>FLASH_WR</u>	F3	FLASH_CLE
F4	GPI_3	F5	VSS_IOC	F6	VSS_IOB
F7	VDD_IOC	F8	VDD_IOB	F9	VDD_IOD
F10	VSS_IOD	F11	VSS_IOD	F12	VSS_IOD
F13	VDD_IOD	F14	KEY_ROW2/ENET_TXD3 <sup>[2]</sup>	F15	KEY_COL0/ENET_TX_CLK <sup>[2]</sup>
F16	KEY_COL5/ENET_RXD1 <sup>[2]</sup>	F17	U6_IRRX/GPI_21	F18	U5_RX/GPI_20
<b>Row G</b>					
G1	<u>EMC_DYCS1</u>	G2	FLASH_IO <sup>[5]</sup>	G3	FLASH_IO <sup>[6]</sup>
G4	<u>RESOUT</u>	G5	VSS_IOC	G6	VDD_IOC
G7	VDD_CORE	G8	VSS_CORE	G9	VDD_CORE
G10	VSS_CORE	G11	VDD_CORE	G12	VSS_CORE
G13	U7_HCTS/CAP0 <sup>[1]</sup> /LCDCLKIN <sup>[1]</sup> /GPI_22	G14	DBGEN	G15	KEY_COL4/ENET_RXD0 <sup>[2]</sup>
G16	U6_IRTX	G17	SYSCLKEN/LCDVD <sup>[15]</sup> <sup>[1]</sup>	G18	JTAG_TMS
<b>Row H</b>					
H1	<u>EMC_OE</u>	H2	FLASH_IO <sup>[0]</sup>	H3	FLASH_IO <sup>[1]</sup>
H4	FLASH_IO <sup>[4]</sup>	H5	VSS_IOC	H6	VDD_IOC
H7	VSS_CORE				
				H12	VSS_IOD
H13	VDD_IOA	H14	JTAG_TCK	H15	U5_TX

Table 3. Pin allocation table (TFBGA296)

Pin	Symbol	Pin	Symbol	Pin	Symbol
H16	HIGHCORE/LCDVD[17] <sup>[1]</sup>	H17	JTAG_NTRST	H18	JTAG_RTCK
<b>Row J</b>					
J1	EMC_A[20]/P1[20]	J2	EMC_A[21]/P1[21]	J3	EMC_A[22]/P1[22]
J4	EMC_A[23]/P1[23]	J5	VDD_IOC	J6	VDD_EMC
J7	VDD_CORE			J12	VDD_CORE
J13	VDD_IOA	J14	U3_RX/GPI_18	J15	JTAG_TDO
J16	JTAG_TDI	J17	U3_TX	J18	U2_HCTS/U3_CTS/GPI_16
<b>Row K</b>					
K1	EMC_A[19]/P1[19]	K2	EMC_A[18]/P1[18]	K3	EMC_A[16]/P1[16]
K4	EMC_A[17]/P1[17]	K5	VSS_EMC	K6	VDD_EMC
K7	VDD_EMC			K12	VSS_CORE
K13	VSS_IOA	K14	VDD_RTC	K15	U1_RX/CAP1[0]/GPI_15
K16	U1_TX	K17	U2_TX/U3_DTR	K18	U2_RX/U3_DSR/GPI_17
<b>Row L</b>					
L1	EMC_A[15]/P1[15]	L2	EMC_CKE1	L3	EMC_A[0]/P1[0]
L4	EMC_A[1]/P1[1]	L5	VSS_EMC	L6	VDD_EMC
L7	VSS_CORE			L12	VDD_COREFXD
L13	VDD_RTCCORE	L14	VSS_RTCCORE	L15	P0[4]/I2S0RX_WS/LCDVD[6] <sup>[1]</sup>
L16	P0[5]/I2S0TX_SDA/LCDVD[7] <sup>[1]</sup>	L17	P0[6]/I2S0TX_CLK/LCDVD[12] <sup>[1]</sup>	L18	P0[7]/I2S0TX_WS/LCDVD[13] <sup>[1]</sup>
<b>Row M</b>					
M1	EMC_A[2]/P1[2]	M2	EMC_A[3]/P1[3]	M3	EMC_A[4]/P1[4]
M4	EMC_A[8]/P1[8]	M5	VSS_EMC	M6	VDD_EMC
M7	VDD_CORE	M8	VDD_EMC	M9	VSS_CORE
M10	VSS_CORE	M11	VDD_CORE	M12	VSS_CORE
M13	VDD_COREFXD	M14	RESET	M15	ONSW
M16	GPO_23/U2_HRTS/U3_RTS	M17	P0[2]/I2S0RX_SDA/LCDVD[4] <sup>[1]</sup>	M18	P0[3]/I2S0RX_CLK/LCDVD[5] <sup>[1]</sup>
<b>Row N</b>					
N1	EMC_A[5]/P1[5]	N2	EMC_A[6]/P1[6]	N3	EMC_A[7]/P1[7]
N4	EMC_A[12]/P1[12]	N5	VSS_EMC	N6	VSS_EMC
N7	VDD_EMC	N8	VDD_EMC	N9	VDD_EMC
N10	VDD_EMC	N11	VDD_EMC	N12	VDD_AD
N13	VDD_AD	N14	VDD_FUSE	N15	VDD_RTCOSC
N16	GPI_5/U3_DCD	N17	GPI_28/U3_RI	N18	GPO_17
<b>Row P</b>					
P1	EMC_A[9]/P1[9]	P2	EMC_A[10]/P1[10]	P3	EMC_A[11]/P1[11]
P4	EMC_DQM[1]	P5	EMC_DQM[3]	P6	VSS_EMC



Table 3. Pin allocation table (TFBGA296)

Pin	Symbol	Pin	Symbol	Pin	Symbol
P7	VSS_EMC	P8	VSS_EMC	P9	VSS_EMC
P10	VSS_EMC	P11	VSS_EMC	P12	EMC_BLS[3]
P13	VSS_AD	P14	VSS_OSC	P15	VDD_PLLUSB
P16	RTCX_IN	P17	RTCX_OUT	P18	VSS_RTCOSC
<b>Row R</b>					
R1	EMC_A[13]/P1[13]	R2	EMC_A[14]/P1[14]	R3	EMC_DQM[0]
R4	EMC_WR	R5	EMC_CAS	R6	EMC_DYCS0
R7	EMC_D[1]	R8	EMC_D[7]	R9	EMC_D[17]/EMC_DQS1
R10	EMC_D[24]/P2[5]	R11	EMC_CS1	R12	EMC_BLS[2]
R13	TS_XP	R14	PLL397_LOOP	R15	SYSX_OUT
R16	VSS_PLLUSB	R17	VDD_PLLHCLK	R18	VSS_PLLHCLK
<b>Row T</b>					
T1	EMC_DQM[2]	T2	EMC_RAS	T3	EMC_CLK
T4	EMC_CLKIN	T5	EMC_D[2]	T6	EMC_D[6]
T7	EMC_D[11]	T8	EMC_D[14]	T9	EMC_D[20]/P2[1]
T10	EMC_D[23]/P2[4]	T11	EMC_D[27]/P2[8]	T12	EMC_CS2
T13	EMC_BLS[1]	T14	ADIN1/TS_XM	T15	VSS_PLL397
T16	VDD_PLL397	T17	SYSX_IN	T18	VDD_OSC
<b>Row U</b>					
		U2	n.c.	U3	EMC_CKE0
U4	EMC_D[0]	U5	EMC_D[3]	U6	EMC_D[9]
U7	EMC_D[12]	U8	EMC_D[15]	U9	EMC_D[19]/P2[0]
U10	EMC_D[22]/P2[3]	U11	EMC_D[26]/P2[7]	U12	EMC_D[30]/P2[11]
U13	EMC_CS0	U14	EMC_BLS[0]	U15	ADIN0/TS_YM
U16	TS_YP	U17	n.c.		
<b>Row V</b>					
				V3	EMC_D[4]
V4	EMC_D[5]	V5	EMC_D[8]	V6	EMC_D[10]
V7	EMC_D[13]	V8	EMC_D[16]/EMC_DQS0	V9	EMC_D[18]/EMC_CLK
V10	EMC_D[21]/P2[2]	V11	EMC_D[25]/P2[6]	V12	EMC_D[28]/P2[9]
V13	EMC_D[29]/P2[10]	V14	EMC_D[31]/P2[12]	V15	EMC_CS3
V16	ADIN2/TS_AUX_IN				

[1] LCD on LPC3230 and LPC3250 only.

[2] Ethernet on LPC3240 and LPC3250 only.

## 6.2 Pin description

Table 4. Pin description

Symbol	Pin	Power supply domain	Type	Description
ADIN0/TS_YM	U15	VDD_AD	analog in	ADC input 0/touch screen Y minus
ADIN1/TS_XM	T14	VDD_AD	analog in	ADC input 0/touch screen X minus
ADIN2/TS_AUX_IN	V16	VDD_AD	analog in	ADC input 2/touch screen AUX input
DBGEN	G14	VDD_IOD	I: PD	Device test input LOW = JTAG in-circuit debug available; normal operation. HIGH = I/O cell boundary scan test; for board assembly BSDI test.
EMC_A[0]/P1[0]	L3	VDD_EMC	I/O	EMC address bit 0
			I/O	Port 1 GPIO bit 0
EMC_A[1]/P1[1]	L4	VDD_EMC	I/O	EMC address bit 1
			I/O	Port 1 GPIO bit 1
EMC_A[2]/P1[2]	M1	VDD_EMC	I/O	EMC address bit 2
			I/O	Port 1 GPIO bit 2
EMC_A[3]/P1[3]	M2	VDD_EMC	I/O	EMC address bit 3
			I/O	Port 1 GPIO bit 3
EMC_A[4]/P1[4]	M3	VDD_EMC	I/O	EMC address bit 4
			I/O	Port 1 GPIO bit 4
EMC_A[5]/P1[5]	N1	VDD_EMC	I/O	EMC address bit 5
			I/O	Port 1 GPIO bit 5
EMC_A[6]/P1[6]	N2	VDD_EMC	I/O	EMC address bit 6
			I/O	Port 1 GPIO bit 6
EMC_A[7]/P1[7]	N3	VDD_EMC	I/O	EMC address bit 7
			I/O	Port 1 GPIO bit 7
EMC_A[8]/P1[8]	M4	VDD_EMC	I/O	EMC address bit 8
			I/O	Port 1 GPIO bit 8
EMC_A[9]/P1[9]	P1	VDD_EMC	I/O	EMC address bit 9
			I/O	Port 1 GPIO bit 9
EMC_A[10]/P1[10]	P2	VDD_EMC	I/O	EMC address bit 10
			I/O	Port 1 GPIO bit 10
EMC_A[11]/P1[11]	P3	VDD_EMC	I/O	EMC address bit 11
			I/O	Port 1 GPIO bit 11
EMC_A[12]/P1[12]	N4	VDD_EMC	I/O	EMC address bit 12
			I/O	Port 1 GPIO bit 12
EMC_A[13]/P1[13]	R1	VDD_EMC	I/O	EMC address bit 13
			I/O	Port 1 GPIO bit 13
EMC_A[14]/P1[14]	R2	VDD_EMC	I/O	EMC address bit 14
			I/O	Port 1 GPIO bit 14

Table 4. Pin description ...continued

Symbol	Pin	Power supply domain	Type	Description
EMC_A[15]/P1[15]	L1	VDD_EMC	I/O	EMC address bit 15
			I/O	Port 1 GPIO bit 15
EMC_A[16]/P1[16]	K3	VDD_EMC	I/O	EMC address bit 16
			I/O	Port 1 GPIO bit 16
EMC_A[17]/P1[17]	K4	VDD_EMC	I/O	EMC address bit 17
			I/O	Port 1 GPIO bit 17
EMC_A[18]/P1[18]	K2	VDD_EMC	I/O	EMC address bit 18
			I/O	Port 1 GPIO bit 18
EMC_A[19]/P1[19]	K1	VDD_EMC	I/O	EMC address bit 19
			I/O	Port 1 GPIO bit 19
EMC_A[20]/P1[20]	J1	VDD_EMC	I/O	EMC address bit 20
			I/O	Port 1 GPIO bit 20
EMC_A[21]/P1[21]	J2	VDD_EMC	I/O	EMC address bit 21
			I/O	Port 1 GPIO bit 21
EMC_A[22]/P1[22]	J3	VDD_EMC	I/O	EMC address bit 22
			I/O	Port 1 GPIO bit 22
EMC_A[23]/P1[23]	J4	VDD_EMC	I/O	EMC address bit 23
			I/O	Port 1 GPIO bit 23
EMC_BLS[0]	U14	VDD_EMC	O	Static memory byte lane 0 select
EMC_BLS[1]	T13	VDD_EMC	O	Static memory byte lane 1 select
EMC_BLS[2]	R12	VDD_EMC	O	Static memory byte lane 2 select
EMC_BLS[3]	P12	VDD_EMC	O	Static memory byte lane 3 select
$\overline{\text{EMC\_CAS}}$	R5	VDD_EMC	O	SDRAM column address strobe out, active LOW
EMC_CKE0	U3	VDD_EMC	O	Clock enable out for SDRAM bank 0
EMC_CKE1	L2	VDD_EMC	O	Clock enable out for SDRAM bank 1
EMC_CLK	T3	VDD_EMC	O	SDRAM clock out
EMC_CLKIN	T4	VDD_EMC	I	SDRAM clock feedback
$\overline{\text{EMC\_CS0}}$	U13	VDD_EMC	O	EMC static memory chip select 0
$\overline{\text{EMC\_CS1}}$	R11	VDD_EMC	O	EMC static memory chip select 1
$\overline{\text{EMC\_CS2}}$	T12	VDD_EMC	O	EMC static memory chip select 2
$\overline{\text{EMC\_CS3}}$	V15	VDD_EMC	O	EMC static memory chip select 3
EMC_D[0]	U4	VDD_EMC	I/O: BK	EMC data bit 0
EMC_D[1]	R7	VDD_EMC	I/O: BK	EMC data bit 1
EMC_D[2]	T5	VDD_EMC	I/O: BK	EMC data bit 2
EMC_D[3]	U5	VDD_EMC	I/O: BK	EMC data bit 3
EMC_D[4]	V3	VDD_EMC	I/O: BK	EMC data bit 4
EMC_D[5]	V4	VDD_EMC	I/O: BK	EMC data bit 5
EMC_D[6]	T6	VDD_EMC	I/O: BK	EMC data bit 6
EMC_D[7]	R8	VDD_EMC	I/O: BK	EMC data bit 7
EMC_D[8]	V5	VDD_EMC	I/O: BK	EMC data bit 8

Table 4. Pin description ...continued

Symbol	Pin	Power supply domain	Type	Description
EMC_D[9]	U6	VDD_EMC	I/O: BK	EMC data bit 9
EMC_D[10]	V6	VDD_EMC	I/O: BK	EMC data bit 10
EMC_D[11]	T7	VDD_EMC	I/O: BK	EMC data bit 11
EMC_D[12]	U7	VDD_EMC	I/O: BK	EMC data bit 12
EMC_D[13]	V7	VDD_EMC	I/O: BK	EMC data bit 13
EMC_D[14]	T8	VDD_EMC	I/O: BK	EMC data bit 14
EMC_D[15]	U8	VDD_EMC	I/O: BK	EMC data bit 15
EMC_D[16]/ EMC_DQS0	V8	VDD_EMC	I/O: BK	EMC data bit 16
			I/O: BK	DDR data strobe 0
EMC_D[17]/ EMC_DQS1	R9	VDD_EMC	I/O: BK	EMC data bit 17
			I/O: BK	DDR data strobe 1
EMC_D[18]/ EMC_CLK	V9	VDD_EMC	I/O: P	EMC data bit 18
			I/O: P	DDR inverted clock output
EMC_D[19]/P2[0]	U9	VDD_EMC	I/O: P	EMC data bit 19
			I/O: P	Port 2 GPIO bit 0
EMC_D[20]/P2[1]	T9	VDD_EMC	I/O: P	EMC data bit 20
			I/O: P	Port 2 GPIO bit 1
EMC_D[21]/P2[2]	V10	VDD_EMC	I/O: P	EMC data bit 21
			I/O: P	Port 2 GPIO bit 2
EMC_D[22]/P2[3]	U10	VDD_EMC	I/O: P	EMC data bit 22
			I/O: P	Port 2 GPIO bit 3
EMC_D[23]/P2[4]	T10	VDD_EMC	I/O: P	EMC data bit 23
			I/O: P	Port 2 GPIO bit 4
EMC_D[24]/P2[5]	R10	VDD_EMC	I/O: P	EMC data bit 24
			I/O: P	Port 2 GPIO bit 5
EMC_D[25]/P2[6]	V11	VDD_EMC	I/O: P	EMC data bit 25
			I/O: P	Port 2 GPIO bit 6
EMC_D[26]/P2[7]	U11	VDD_EMC	I/O: P	EMC data bit 26
			I/O: P	Port 2 GPIO bit 7
EMC_D[27]/P2[8]	T11	VDD_EMC	I/O: P	EMC data bit 27
			I/O: P	Port 2 GPIO bit 8
EMC_D[28]/P2[9]	V12	VDD_EMC	I/O: P	EMC data bit 28
			I/O: P	Port 2 GPIO bit 9
EMC_D[29]/P2[10]	V13	VDD_EMC	I/O: P	EMC data bit 29
			I/O: P	Port 2 GPIO bit 10
EMC_D[30]/P2[11]	U12	VDD_EMC	I/O: P	EMC data bit 30
			I/O: P	Port 2 GPIO bit 11
EMC_D[31]/P2[12]	V14	VDD_EMC	I/O: P	EMC data bit 31
			I/O: P	Port 2 GPIO bit 12
EMC_DQM[0]	R3	VDD_EMC	O	SDRAM data mask 0 out

Table 4. Pin description ...continued

Symbol	Pin	Power supply domain	Type	Description
EMC_DQM[1]	P4	VDD_EMC	O	SDRAM data mask 1 out
EMC_DQM[2]	T1	VDD_EMC	O	SDRAM data mask 2 out
EMC_DQM[3]	P5	VDD_EMC	O	SDRAM data mask 3 out
EMC_DYCS0	R6	VDD_EMC	O	SDRAM active LOW chip select 0
EMC_DYCS1	G1	VDD_EMC	O	SDRAM active LOW chip select 1
EMC_OE	H1	VDD_EMC	O	EMC static memory output enable
EMC_RAS	T2	VDD_EMC	O	SDRAM row address strobe, active LOW
EMC_WR	R4	VDD_EMC	O	EMC write strobe, active LOW
FLASH_ALE	D2	VDD_IOC	O	Flash address latch enable
FLASH_CE	E3	VDD_IOC	O	Flash chip enable
FLASH_CLE	F3	VDD_IOC	O	Flash command latch enable
FLASH_IO[0]	H2	VDD_IOC	I/O: BK	Flash data bus, bit 0
FLASH_IO[1]	H3	VDD_IOC	I/O: BK	Flash data bus, bit 1
FLASH_IO[2]	F1	VDD_IOC	I/O: BK	Flash data bus, bit 2
FLASH_IO[3]	E1	VDD_IOC	I/O: BK	Flash data bus, bit 3
FLASH_IO[4]	H4	VDD_IOC	I/O: BK	Flash data bus, bit 4
FLASH_IO[5]	G2	VDD_IOC	I/O: BK	Flash data bus, bit 5
FLASH_IO[6]	G3	VDD_IOC	I/O: BK	Flash data bus, bit 6
FLASH_IO[7]	E2	VDD_IOC	I/O: BK	Flash data bus, bit 7
FLASH_RD	C1	VDD_IOC	O	Flash read enable
FLASH_RDY	D1	VDD_IOC	I	Flash ready (from flash device)
FLASH_WR	F2	VDD_IOC	O	Flash write enable
GPI_0/I2S1RX_SDA	C16	VDD_IOD	I	General purpose input 0
			I	I <sup>2</sup> S1 Receive data
GPI_1/SERVICE	C15	VDD_IOD	I	General purpose input 1
			I	Boot select input
GPI_2/CAP2[0]/ENET_RXD3	C14	VDD_IOD	I	General purpose input 2
			I	Timer 2 capture input 0
			I	Ethernet receive data 3 (LPC3240 and LPC3250 only)
GPI_3	F4	VDD_IOC	I	General purpose input 3
GPI_4/SPI1_BUSY	E13	VDD_IOD	I	General purpose input 4
			I	SPI1 busy input
GPI_5/U3_DCD	N16	VDD_IOA	I	General purpose input 5
			I	UART 3 data carrier detect input
GPI_6/HSTIM_CAP/ENET_RXD2	C7	VDD_IOB	I: BK	General purpose input 6
			I: BK	High-speed timer capture input
			I: BK	Ethernet receive data 2 (LPC3240 and LPC3250 only)

Table 4. Pin description ...continued

Symbol	Pin	Power supply domain	Type	Description
GPI_7/CAP4[0]/ MCABORT	D13	VDD_IOD	I	General purpose input 7
			I	Timer 4 capture input 0
			I	Motor control PWM LOW-active fast abort input
GPI_8/KEY_COL6/ SPI2_BUSY/ ENET_RX_DV	B16	VDD_IOD	I	General purpose input 8
			I	Keyscan column 6 input
			I	SPI2 busy input
			I	Ethernet receive data valid input (LPC3240 and LPC3250 only)
GPI_9/KEY_COL7/ ENET_COL	E12	VDD_IOD	I	General purpose input 9
			I	Keyscan column 7 input
			I	Ethernet collision input (LPC3240 and LPC3250 only)
GPI_19/U4_RX	B15	VDD_IOD	I	General purpose input 19
			I	UART 4 receive
GPI_28/U3_RI	N17	VDD_IOA	I	General purpose input 28
			I	UART 3 ring indicator input
GPIO_0	A12	VDD_IOD	I/O	General purpose input/output 0
GPIO_1	A11	VDD_IOD	I/O	General purpose input/output 1
GPIO_2/ KEY_ROW6/ ENET_MDC	D9	VDD_IOD	I/O	General purpose input/output 2
			O	Keyscan row 6 output
			O	Ethernet PHY interface clock (LPC3240 and LPC3250 only)
GPIO_3/ KEY_ROW7/ ENET_MDIO	C11	VDD_IOD	I/O	General purpose input/output 3
			I/O	Keyscan row 7 output
			I/O	Ethernet PHY interface data (LPC3240 and LPC3250 only)
GPIO_4/ SSEL1/ LCDVD[22]	B11	VDD_IOD	I/O	General purpose input/output 4
			I/O	SSP1 Slave Select
			I/O	LCD data bit 22 (LPC3230 and LPC3250 only)
GPIO_5/ SSEL0/ MCIO	E9	VDD_IOD	I/O	General purpose input/output 5
			I/O	SSP0 Slave Select
			I/O	Motor control channel 0 input
GPO_0/ TST_CLK1	C3	VDD_IOC	O	General purpose output 0
			O	Test clock 1 out
GPO_1	D4	VDD_IOC	O	General purpose output 1
GPO_2/ MAT1[0]/ LCDVD[0]	B14	VDD_IOD	O	General purpose output 2
			O	Timer 1 match output 0
			O	LCD data bit 0 (LPC3230 and LPC3250 only)
GPO_3/ LCDVD[1]	D12	VDD_IOD	O	General purpose output 3
			O	LCD data bit 1 (LPC3230 and LPC3250 only)
GPO_4	D8	VDD_IOB	O	General purpose output 4

Table 4. Pin description ...continued

Symbol	Pin	Power supply domain	Type	Description
GPO_5	B3	VDD_IOC	O	General purpose output 5
GPO_6/ LCDVD[18]	A16	VDD_IOD	O	General purpose output 6
			O	LCD data bit 18 (LPC3230 and LPC3250 only)
GPO_7/ LCDVD[2]	A15	VDD_IOD	O	General purpose output 7
			O	LCD data bit 2 (LPC3230 and LPC3250 only)
GPO_8/ LCDVD[8]	C13	VDD_IOD	O	General purpose output 8
			O	LCD data bit 8 (LPC3230 and LPC3250 only)
GPO_9/ LCDVD[9]	C12	VDD_IOD	O	General purpose output 9
			O	LCD data bit 9 (LPC3230 and LPC3250 only)
GPO_10/ MCOB2/ LCDPWR	E11	VDD_IOD	O	General purpose output 10
			O	Motor control PWM channel 2, output B
			O	LCD panel power enable (LPC3230 and LPC3250 only)
GPO_11	E8	VDD_IOB	O	General purpose output 11
GPO_12/ MCOA2/ LCDLE	B12	VDD_IOD	O	General purpose output 12
			O	Motor control PWM channel 2, output A
			O	LCD line end signal (LPC3230 and LPC3250 only)
GPO_13/ MCOB1/ LCDDCLK	B13	VDD_IOD	O	General purpose output 13
			O	Motor control PWM channel 1, output B
			O	LCD clock output (LPC3230 and LPC3250 only)
GPO_14	D3	VDD_IOC	O	General purpose output 14
GPO_15/ MCOA1/ LCDFP	A14	VDD_IOD	O	General purpose output 15
			O	Motor control PWM channel 1, output A
			O	LCD frame/sync pulse (LPC3230 and LPC3250 only)
GPO_16/ MCOB0/ LCDENAB/LCDM	D10	VDD_IOD	O	General purpose output 16
			O	Motor control PWM channel 0, output B
			O	LCD STN AC bias/TFT data enable (LPC3230 and LPC3250 only)
GPO_17	N18	VDD_IOA	O	General purpose output 17
GPO_18/ MCOA0/ LCDLP	D11	VDD_IOD	O	General purpose output 18
			O	Motor control PWM channel 0, output A
			O	LCD line sync/horizontal sync (LPC3230 and LPC3250 only)
GPO_19	C2	VDD_IOC	O	General purpose output 19
GPO_20	B2	VDD_IOC	O	General purpose output 20
GPO_21/ U4_TX/ LCDVD[3]	A13	VDD_IOD	O	General purpose output 21
			O	UART 4 transmit
			O	LCD data bit 3 (LPC3230 and LPC3250 only)

Table 4. Pin description ...continued

Symbol	Pin	Power supply domain	Type	Description
GPO_22/ U7_HRTS/ LCDVD[14]	E10	VDD_IOD	O	General purpose output 22
			O	HS UART 7 RTS out
			O	LCD data bit 14 (LPC3230 and LPC3250 only)
GPO_23/ U2_HRTS/ U3_RTS	M16	VDD_IOA	O	General purpose output 23
			O	HS UART 2 RTS out
			O	UART 3 RTS out
HIGHCORE/ LCDVD[17]	H16	VDD_IOD	O	Core voltage control out
			O	LCD data bit 17 (LPC3230 and LPC3250 only)
I2C1_SCL	A5	VDD_IOB	I/O T	I <sup>2</sup> C1 serial clock input/output
I2C1_SDA	B6	VDD_IOB	I/O T	I <sup>2</sup> C1 serial data input/output
I2C2_SCL	A3	VDD_IOC	I/O T	I <sup>2</sup> C2 serial clock input/output
I2C2_SDA	E4	VDD_IOC	I/O T	I <sup>2</sup> C2 serial data input/output
I2S1TX_CLK/ MAT3[0]	A4	VDD_IOB	I/O	I <sup>2</sup> S1 transmit clock
			O	Timer 3 match output 0
I2S1TX_SDA/ MAT3[1]	E7	VDD_IOB	I/O	I <sup>2</sup> S1 transmit data
			O	Timer 3 match output 1
I2S1TX_WS/ CAP3[0]	B4	VDD_IOB	I/O	I <sup>2</sup> S1 transmit word select
			I/O	Timer 3 capture input 0
JTAG_NTRST	H17	VDD_IOD	I: PU	JTAG1 reset input. Must be LOW during power-on reset. See <a href="#">Section 12.1 “Connecting the JTAG_NTRST pin”</a> .
JTAG_RTCK	H18	VDD_IOD	O	JTAG1 return clock out
JTAG_TCK	H14	VDD_IOD	I	JTAG1 clock input
JTAG_TDI	J16	VDD_IOD	I: PU	JTAG1 data input
JTAG_TDO	J15	VDD_IOD	O	JTAG1 data out
JTAG_TMS	G18	VDD_IOD	I: PU	JTAG1 test mode select input
KEY_COLO/ ENET_TX_CLK	F15	VDD_IOD	I	Keyscan column 0 input
			I	Ethernet transmit clock (LPC3240 and LPC3250 only)
KEY_COL1/ ENET_RX_CLK/ ENET_REF_CLK	E16	VDD_IOD	I	Keyscan column 1 input
			I	Ethernet receive clock (MII mode, LPC3240 and LPC3250 only)
			I	Ethernet reference clock (RMII mode, LPC3240 and LPC3250 only)
KEY_COL2/ ENET_RX_ER	D17	VDD_IOD	I	Keyscan column 2 input
			I	Ethernet receive error input (LPC3240 and LPC3250 only)
KEY_COL3/ ENET_CRS	D18	VDD_IOD	I	Keyscan column 3 input
			I	Ethernet carrier sense input (LPC3240 and LPC3250 only)



Table 4. Pin description ...continued

Symbol	Pin	Power supply domain	Type	Description
KEY_COL4/ ENET_RXD0	G15	VDD_IOD	I	Keyscan column 4 input
			I	Ethernet receive data 0 (LPC3240 and LPC3250 only)
KEY_COL5/ ENET_RXD1	F16	VDD_IOD	I	Keyscan column 5 input
			I	Ethernet receive data 1 (LPC3240 and LPC3250 only)
KEY_ROW0/ ENET_TX_ER	E15	VDD_IOD	I/O T	Keyscan row 0 out
			I/O T	Ethernet transmit error (LPC3240 and LPC3250 only)
KEY_ROW1/ ENET_TXD2	E14	VDD_IOD	I/O T	Keyscan row 1 out
			I/O T	Ethernet transmit data 2 (LPC3240 and LPC3250 only)
KEY_ROW2/ ENET_TXD3	F14	VDD_IOD	I/O T	Keyscan row 2 out
			I/O T	Ethernet transmit data 3 (LPC3240 and LPC3250 only)
KEY_ROW3/ ENET_TX_EN	D16	VDD_IOD	I/O T	Keyscan row 3 out
			I/O T	Ethernet transmit enable (LPC3240 and LPC3250 only)
KEY_ROW4/ ENET_TXD0	C17	VDD_IOD	I/O T	Keyscan row 4 out
			I/O T	Ethernet transmit data 0 (LPC3240 and LPC3250 only)
KEY_ROW5/ ENET_TXD1	C18	VDD_IOD	I/O T	Keyscan row 5 out
			I/O T	Ethernet transmit data 1 (LPC3240 and LPC3250 only)
MS_BS/MAT2[1]	A6	VDD_IOD	I/O: P	MS/SD card command out
			O	Timer 2 match output 1
MS_DIO0/MAT0[0]	A8	VDD_IOD	I/O: P	MS/SD card data 0
			O	Timer 0 match output 0
MS_DIO1/ MAT0[1]	A7	VDD_IOD	I/O: P	MS/SD card data 1
			O	Timer 0 match output 1
MS_DIO2/ MAT0[2]	B8	VDD_IOD	I/O: P	MS/SD card data 2
			O	Timer 0 match output 2
MS_DIO3/ MAT0[3]	C8	VDD_IOD	I/O: P	MS/SD card data 3
			O	Timer 0 match output 3
MS_SCLK/ MAT2[0]	B7	VDD_IOD	I/O	MS/SD card clock output
			O	Timer 2 match output 0
n.c.	B17, U17, U2	-	-	not connected
ONSW	M15	VDD_RTC	O	RTC match output for external power control
P0[0]/ I2S1RX_CLK	B5	VDD_IOB	I/O	Port 0 GPIO bit 0
			I/O	I2S1 receive clock

Table 4. Pin description ...continued

Symbol	Pin	Power supply domain	Type	Description
P0[1]/ I2S1RX_WS	D7	VDD_IOB	I/O	Port 0 GPIO bit 1
			I/O	I <sup>2</sup> S1 receive word select
P0[2]/ I2S0RX_SDA/ LCDVD[4]	M17	VDD_IOA	I/O	Port 0 GPIO bit 2
			I/O	I <sup>2</sup> S0 receive data
			I/O	LCD data bit 4 (LPC3230 and LPC3250 only)
P0[3]/ I2S0RX_CLK/ LCDVD[5]	M18	VDD_IOA	I/O	Port 0 GPIO bit 3
			I/O	I <sup>2</sup> S0 receive clock
			I/O	LCD data bit 5 (LPC3230 and LPC3250 only)
P0[4]/ I2S0RX_WS/ LCDVD[6]	L15	VDD_IOA	I/O	Port 0 GPIO bit 4
			I/O	I <sup>2</sup> S0 receive word select
			I/O	LCD data bit 6 (LPC3230 and LPC3250 only)
P0[5]/ I2S0TX_SDA/ LCDVD[7]	L16	VDD_IOA	I/O	Port 0 GPIO bit 5
			I/O	I <sup>2</sup> S0 transmit data
			I/O	LCD data bit 7 (LPC3230 and LPC3250 only)
P0[6]/ I2S0TX_CLK/ LCDVD[12]	L17	VDD_IOA	I/O	Port 0 GPIO bit 6
			I/O	I <sup>2</sup> S0 transmit clock
			I/O	LCD data bit 12 (LPC3230 and LPC3250 only)
P0[7]/ I2S0TX_WS/ LCDVD[13]	L18	VDD_IOA	I/O	Port 0 GPIO bit 7
			I/O	I <sup>2</sup> S0 transmit word select
			I/O	LCD data bit 13 (LPC3230 and LPC3250 only)
PLL397_LOOP	R14	VDD_PLL397	analog filter	PLL397 loop filter (for external components)
PWM_OUT1/ LCDVD[16]	D14	VDD_IOD	O	PWM1 out
			O	LCD data bit 16 (LPC3230 and LPC3250 only)
PWM_OUT2/INTSTAT/ LCDVD[19]	D15	VDD_IOD	O	PWM2 output/internal interrupt status <sup>[1]</sup>
			O	LCD data bit 19 (LPC3230 and LPC3250 only)
RESET	M14	VDD_RTC	I	Reset input, active LOW
RESOUT	G4	VDD_IOC	O	Reset out. Reflects external and WDT reset
RTCX_IN	P16	VDD_RTC	analog in	RTC oscillator input
RTCX_OUT	P17	VDD_RTC	analog out	RTC oscillator output
SPI1_CLK/ SCK0	C9	VDD_IOD	O	SPI1 clock out
			O	SSP0 clock out
SPI1_DATIN/ MISO0/ GPI_25/ MCI1	C10	VDD_IOD	I/O	SPI1 data in
			I/O	SSP0 MISO
			I/O	General purpose input bit 25
			I	Motor control channel 1 input
SPI1_DATIO/ MOSI0/ MCI2	B9	VDD_IOD	I/O	SPI1 data out (and optional input)
			I/O	SSP0 MOSI
			I	Motor control channel 2 input

Table 4. Pin description ...continued

Symbol	Pin	Power supply domain	Type	Description
SPI2_CLK/ SCK1/ LCDVD[23]	B10	VDD_IOD	I/O	SPI2 clock out
			I/O	SSP1 clock out
			I/O	LCD data bit 23 (LPC3230 and LPC3250 only)
SPI2_DATIO/ MOSI1/ LCDVD[20]	A9	VDD_IOD	I/O	SPI2 data out (and optional input)
			I/O	SSP1 MOSI
			I/O	LCD data bit 20 (LPC3230 and LPC3250 only)
SPI2_DATIN/ MISO1/ LCDVD[21]/ GPI_27	A10	VDD_IOD	I/O	SPI2 data in
			I/O	SSP1 MISO
			I/O	LCD data bit 21 (LPC3230 and LPC3250 only)
			I/O	General purpose input bit 27
SYSCLKEN/ LCDVD[15]	G17	VDD_IOD	I/O T	Clock request out for external clock source
			I/O T	LCD data bit 15 (LPC3230 and LPC3250 only)
SYSX_IN	T17	VDD_OSC	analog in	System clock oscillator input
SYSX_OUT	R15	VDD_OSC	analog out	System clock oscillator output
TS_XP	R13	VDD_AD	I/O	Touchscreen X output
TS_YP	U16	VDD_AD	I/O	Touchscreen Y output
TST_CLK2	C6	VDD_IOB	O	Test clock 2 out
U1_RX/CAP1[0]/ GPI_15	K15	VDD_IOA	I/O	HS UART 1 receive
			I/O	Timer 1 capture input 0
			I/O	General purpose input bit 15
U1_TX	K16	VDD_IOA	O	HS UART 1 transmit
U2_HCTS/ U3_CTS/GPI_16	J18	VDD_IOA	I/O	HS UART 2 Clear to Send input
			I	UART 3 Clear to Send
			I/O	General purpose input bit 16
U2_RX/ U3_DSR/GPI_17	K18	VDD_IOA	I/O	HS UART 2 receive
			I/O	UART 3 data set ready
			I/O	General purpose input bit 17
U2_TX/U3_DTR	K17	VDD_IOA	O	HS UART 2 transmit
			O	UART 3 data terminal ready out
U3_RX/ GPI_18	J14	VDD_IOD	I/O	UART 3 receive
			I/O	General purpose input bit 18
U3_TX	J17	VDD_IOD	O	UART 3 transmit
U5_RX/ GPI_20	F18	VDD_IOD	I/O	UART 5 receive
			I	General purpose input bit 20
U5_TX	H15	VDD_IOD	O	UART 5 transmit
U6_IRRX/ GPI_21	F17	VDD_IOD	I/O	UART 6 receive (with IrDA)
			I	General purpose input bit 21
U6_IRTX	G16	VDD_IOD	O	UART 6 transmit (with IrDA)

Table 4. Pin description ...continued

Symbol	Pin	Power supply domain	Type	Description
U7_HCTS/ CAP0[1]/ LCDCLKIN/ GPI_22	G13	VDD_IOD	I	HS UART 7 CTS in
			I	Timer 0 capture input 1
			I	LCD panel clock in (LPC3230 and LPC3250 only)
			I	General purpose input bit 22
U7_RX/ CAP0[0]/ LCDVD[10]/ GPI_23	E17	VDD_IOD	I/O	HS UART 7 receive
			I/O	Timer 0 capture input 0
			I/O	LCD data bit 10 (LPC3230 and LPC3250 only)
			I/O	General purpose input bit 23
U7_TX/ MAT1[1]/ LCDVD[11]	E18	VDD_IOD	O	HS UART 7 transmit
			O	Timer 1 match output 1
			O	LCD data bit 11 (LPC3230 and LPC3250 only)
USB_ATX_INT	C4	VDD_IOC	I	Interrupt from USB ATX
USB_DAT_VP/ U5_RX	D5	VDD_IOC	I/O: P	USB transmit data, D+ receive
			I/O: P	UART 5 receive
USB_I2C_SCL	E5	VDD_IOC	I/O T	I <sup>2</sup> C clock for USB ATX interface
USB_I2C_SDA	E6	VDD_IOC	I/O T	I <sup>2</sup> C data for USB ATX interface
USB_OE_TP	D6	VDD_IOC	I/O	USB transmit enable for DAT/SE0
USB_SE0_VM/ U5_TX	C5	VDD_IOC	I/O: P	USB single ended zero transmit, D- Receive
			I/O: P	UART 5 transmit
VDD_AD	N12, N13	VDD_AD	power	3.3 V supply for ADC/touch screen
VDD_CORE	G7, G9, G11, J7, J12, M7, M11	VDD_CORE	power	1.2 V or 0.9 V supply for core
VDD_COREFXD	L12, M13	VDD_COREFXD	power	Fixed 1.2 V supply for digital portion of the analog block
VDD EMC	J6, K6, K7, L6, M6, M8, N7, N8, N9, N10, N11	VDD EMC	power	1.8 V or 2.5 V or 3.3 V supply for External Memory Controller (EMC)
VDD_IOA	H13, J13	VDD_IOA	power	1.8 V or 3.3 V supply for IOA domain
VDD_IOB	F8	VDD_IOB	power	1.8 V or 3.3 V supply for IOB domain

Table 4. Pin description ...continued

Symbol	Pin	Power supply domain	Type	Description
VDD_IOC	F7, G6, H6, J5	VDD_IOC	power	1.8 V or 3.3 V supply for IOC domain
VDD_IOD	F13, F9	VDD_IOD	power	1.8 V to 3.3 V supply for IOD domain
VDD_OSC	T18	VDD_OSC	power	1.2 V supply for main oscillator
VDD_PLL397	T16	VDD_PLL397	power	1.2 V supply for 397x PLL
VDD_PLLHCLK	R17	VDD_PLLHCLK	power	1.2 V supply for HCLK PLL
VDD_PLLUSB	P15	VDD_PLLUSB	power	1.2 V supply for USB PLL
VDD_FUSE	N14	VDD_FUSE	power	1.2 V supply
VDD_RTC	K14	VDD_RTC	power	1.2 V supply for RTC I/O
VDD_RTCCORE	L13	VDD_RTCCORE	power	1.2 V supply for RTC
VDD_RTCOSC	N15	VDD_RTCOSC	power	1.2 V supply for RTC oscillator
VSS_AD	P13	-	power	Ground for ADC/touch screen
VSS_CORE	G8, G10, G12, H7, K12, L7, M9, M10, M12	-	power	Ground for core
VSS_EMC	K5, L5, M5, N5, N6, P6, P7, P8, P9, P10, P11	-	power	Ground for EMC
VSS_IOA	K13	-	power	Ground VDD_IOA domain
VSS_IOB	F6	-	power	Ground VDD_IOB domain
VSS_IOC	F5, G5, H5	-	power	Ground VDD_IOC domain
VSS_IOD	F10, F11, F12, H12	-	power	Ground VDD_IOD domain
VSS_OSC	P14	-	power	Ground for main oscillator
VSS_PLL397	T15	-	power	Ground for 397x PLL
VSS_PLLHCLK	R18	-	power	Ground for HCLK PLL

Table 4. Pin description ...continued

Symbol	Pin	Power supply domain	Type	Description
VSS_PLLUSB	R16	-	power	Ground for USB PLL
VSS_RTCCORE	L14	-	power	Ground for RTC
VSS_RTCOSC	P18	-	power	Ground for RTC oscillator

[1] The PWM2\_CTRL register controls this pin function (see LPC32x0 User manual).

Table 5. Digital I/O pad types<sup>[1]</sup>

Parameter	Abbreviation
I/O type	I = input. O = output. I/O = bidirectional. I/O T = bidirectional or high impedance.
Pin detail	BK: pin has a bus keeper function that weakly retains the last logic level driven on an I/O pin. Bus keeper current for different I/O pin voltages: 0 V = 1 μA (max) VDD_x = 1 μA (max) 2/3 × VDD_x = 55 μA (max) 1/3 × VDD_x = 60 μA (max) PU: pin has a nominal 50 μA internal pull-up connected. PD: pin has a nominal 50 μA internal pull-down connected. P: pin has programmable input characteristics.

[1] See LPC32x0 User manual for details.

Table 6. Supply domains

Supply domain	Voltage range	Related supply pins	Description
VDD_CORE	0.9 V to 1.39 V	VDD_CORE	Core power domain.
VDD_COREFXD	1.2 V	VDD_COREFXD	Fixed 1.2 V supply for digital portion of the analog block.
other core domains	1.2 V	VDD_PLL397, VDD_PLLHCLK, VDD_PLLUSB, VDD_FUSE, VDD_OSC	1.2 V supplies, tied to VDD_COREFXD.
VDD_RTC	0.9 V to 1.39 V	VDD_RTC, VDD_RTCCORE, VDD_RTCOSC	RTC supply domain. Can be connected to a battery backed-up power source.
VDD_AD	2.7 V to 3.6 V	VDD_AD	3.3 V supply for ADC and touch screen.
VDD_EMCC	1.7 V to 1.95 V 2.3 V to 2.7 V 2.7 V to 3.6 V	VDD_EMCC	External memory interface IO pins in 1.8 V range, 2.5 V range, or 3.3 V range.

Table 6. Supply domains

Supply domain	Voltage range	Related supply pins	Description
VDD_IOA <sup>[1]</sup>	1.7 V to 1.95 V or 2.7 V to 3.6 V	VDD_IOA	Peripheral supply.
VDD_IOB <sup>[1]</sup>	1.7 V to 1.95 V or 2.7 V to 3.6 V	VDD_IOB	Peripheral supply.
VDD_IOC <sup>[1]</sup>	1.7 V to 1.95 V or 2.3 V to 3.6 V	VDD_IOC	Peripheral supply.
VDD_IOD <sup>[1]</sup>	1.7 V to 1.95 V or 2.7 V to 3.6 V	VDD_IOD	Peripheral supply.

[1] The VDD\_IOA, VDD\_IOB, VDD\_IOC, and VDD\_IOD supply domains can be operated at a voltage independent of the other domains as long as all pins connected to the same peripheral are at the same voltage level. There are two special cases for determining supply domain voltages (for details see *application note AN10777*):

- a) Ethernet configured in MII mode: VDD\_IOD must be the same as VDD\_IOB.
- b) UART 3 when used with hardware flow control or when sharing an RS-232 transceiver with another UART: VDD\_IOA must be the same as VDD\_IOD.

## 7. Functional description

### 7.1 CPU and subsystems

#### 7.1.1 CPU

NXP created the LPC3220/30/40/50 using an ARM926EJ-S CPU core that includes a Harvard architecture and a 5-stage pipeline. To this ARM core, NXP implemented a 32 kB instruction cache, a 32 kB data cache and a Vector Floating Point coprocessor. The ARM926EJ-S core also has an integral Memory Management Unit (MMU) to provide the virtual memory capabilities required to support the multi-programming demands of modern operating systems. The basic ARM926EJ-S core V5TE instruction set includes DSP instruction extensions for native Jazelle Java Byte-code execution in hardware. The LPC3220/30/40/50 operates at CPU frequencies up to 266 MHz.

#### 7.1.2 Vector Floating Point (VFP) coprocessor

The LPC3220/30/40/50 includes a VFP co-processor providing full support for single-precision and double-precision add, subtract, multiply, divide, and multiply-accumulate operations at CPU clock speeds. It is compliant with the IEEE 754 standard for binary Floating-Point Arithmetic. This hardware floating point capability makes the microcontroller suitable for advanced motor control and DSP applications. The VFP has 3 separate pipelines for floating-point MAC operations, divide or square root operations, and Load/Store operations. These pipelines operate in parallel and can complete execution out of order. All single-precision instructions execute in one cycle, except the divide and square root instructions. All double-precision multiply and multiply-accumulate instructions take two cycles. The VFP also provides format conversions between floating-point and integer word formats.

#### 7.1.3 Emulation and debugging

The LPC3220/30/40/50 supports emulation and debugging via a dedicated JTAG serial port. An Embedded Trace Buffer allows tracing program execution. The dedicated JTAG port allows debugging of all chip features without impact to any pins that may be used in the application.

##### 7.1.3.1 Embedded ICE

Standard ARM EmbeddedICE logic provides on-chip debug support. The debugging of the target system requires a host computer running the debugger software and an Embedded ICE protocol converter. The Embedded ICE protocol converter converts the Remote Debug Protocol commands to the JTAG data needed to access the ARM core.

The ARM core has a Debug Communication Channel (DCC) function built-in. The debug communication channel allows a program running on the target to communicate with the host debugger or another separate host without stopping the program flow or entering the debug state.



### 7.1.3.2 Embedded trace buffer

The Embedded Trace Module (ETM) is connected directly to the ARM core. It compresses the trace information and exports it through a narrow trace port. An internal Embedded Trace Buffer (ETB) of 2048 × 24 bits captures the trace information under software debugger control. Data from the ETB is recovered by the debug software through the JTAG port.

The trace contains information about when the ARM core switches between states. Instruction shows the flow of execution of the processor and provides a list of all the instructions that were executed. Instruction trace is significantly compressed by only broadcasting branch addresses as well as a set of status signals that indicate the pipeline status on a cycle by cycle basis. For data accesses either data or address or both can be traced.

## 7.2 AHB matrix

The LPC3220/30/40/50 has a multi-layer AHB matrix for inter-block communication. AHB is an ARM defined high-speed bus, which is part of the ARM bus architecture. AHB is a high-bandwidth low-latency bus that supports multi-master arbitration and a bus grant/request mechanism. For systems that have only one (CPU), or two (CPU and DMA) bus masters a simple AHB works well. However, if a system requires multiple bus masters and the CPU needs access to external memory, a single AHB bus can cause a bottleneck.

To increase performance, the LPC3220/30/40/50 uses an expanded AHB architecture known as Multi-layer AHB. A Multi-layer AHB replaces the request/grant and arbitration mechanism used in a simple AHB with an interconnect matrix that moves arbitration out toward the slave devices. Thus, if a CPU and a DMA controller want access to the same memory, the interconnect matrix arbitrates between the two when granting access to the memory. This advanced architecture allows simultaneous access by bus masters to different resources with an increase in arbitration complexity. In this architectural implementation, removing guaranteed central arbitration and allowing more than one bus master to be active at the same time provides better overall microcontroller performance.

In the LPC3220/30/40/50, the multi-Layer AHB system has a separate bus for each of seven AHB Masters:

- CPU data bus
- CPU instruction bus
- General purpose DMA Master 0
- General purpose DMA Master 1
- Ethernet controller
- USB controller
- LCD controller

There are no arbitration delays unless two masters attempt to access the same slave at the same time.

### 7.2.1 APB

Many peripheral functions are accessed by on-chip APBs that are attached to the higher speed AHB. The APB performs reads and writes to peripheral registers in three peripheral clocks.

### 7.2.2 FAB

Some peripherals are placed on a special bus called FAB that allows faster CPU access to those peripheral functions. A write access to FAB peripherals takes a single AHB clock and a read access to FAB peripherals takes two AHB clocks.

## 7.3 Physical memory map

The physical memory map incorporates several distinct regions, as shown in [Figure 3](#). When an application is running, the CPU interrupt vectors are re-mapped to allow them to reside in on-chip SRAM (IRAM).

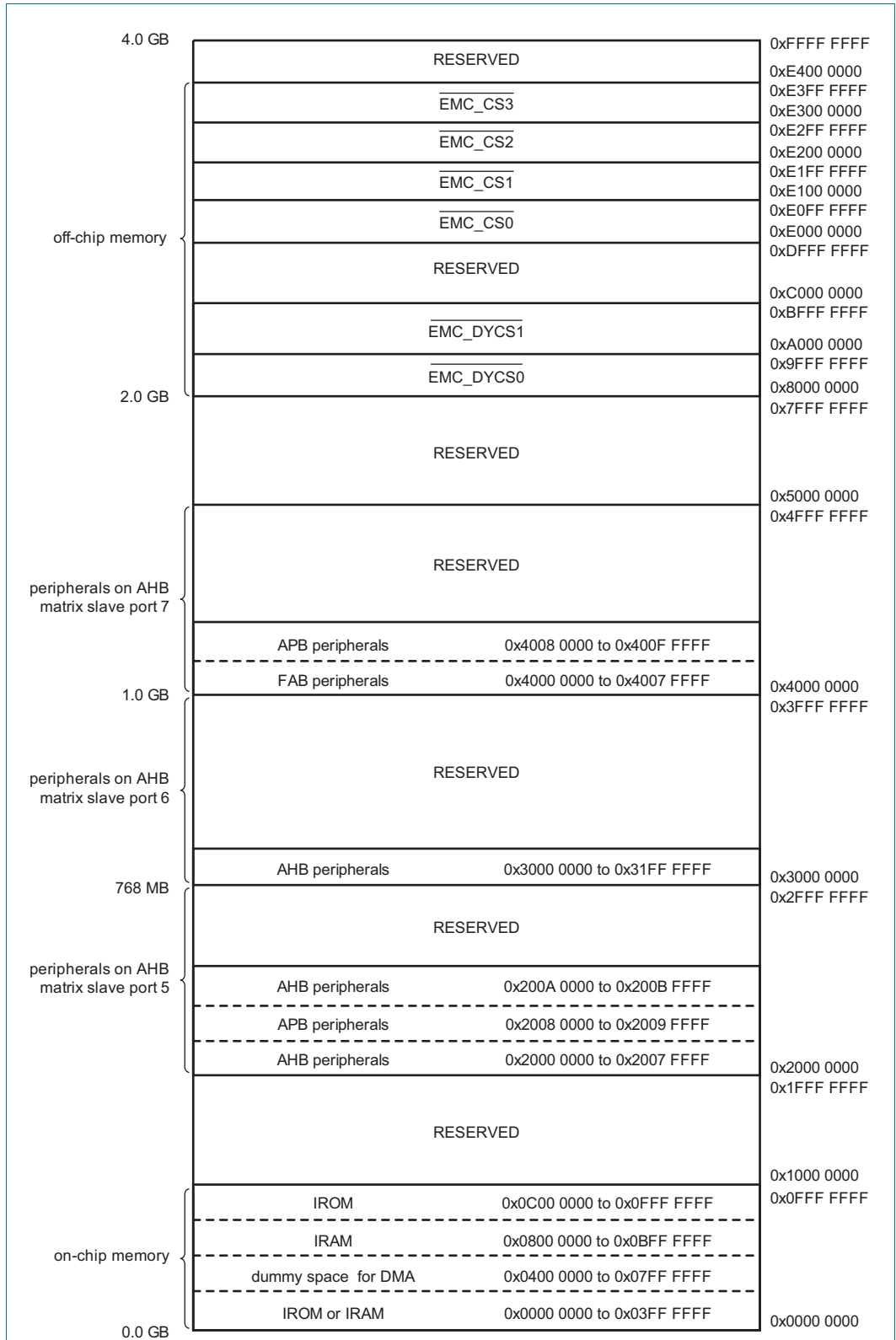

002aae468

Fig 3. LPC3220/30/40/50 memory map

## 7.4 Internal memory

### 7.4.1 On-chip ROM

The built-in 16 kB ROM contains a program which runs a boot procedure to load code from one of four external sources, UART 5, SSP0 (SPI mode), EMC Static CS0 memory, or NAND FLASH.

After reset, execution always begins from the internal ROM. The bootstrap software first reads the  $\overline{\text{SERVICE}}$  input (GPI\_1). If  $\overline{\text{SERVICE}}$  is LOW, the bootstrap starts a service boot and can download a program over serial link UART 5 to IRAM and transfer execution to the downloaded code.

If the  $\overline{\text{SERVICE}}$  pin is HIGH, the bootstrap routine jumps to normal boot. The normal boot process first tests SPI memory for boot information if present it uploads the boot code and transfers execution to the uploaded software. If the SPI is not present or no software is loaded, the boot loader will test the EMC Static CS0 memory for the presence of boot code and if present boots from static memory, If this test fails the boot loader will test external NAND flash for boot code and boot if code is present.

The boot loader consumes no user memory space because it is in ROM.

### 7.4.2 On-chip SRAM

On-chip SRAM may be used for code and/or data storage. The SRAM may be accessed as 8, 16, or 32 bit memory. The LPC3220/30/40/50 provides 256 kB of internal SRAM.

## 7.5 External memory interfaces

The LPC3220/30/40/50 includes three external memory interfaces, NAND Flash controllers, Secure Digital Memory Controller, and an external memory controller for SDRAM, DDR SDRAM, and Static Memory devices.

### 7.5.1 NAND flash controllers

The LPC3220/30/40/50 includes two NAND flash controllers, one for multi-level cell NAND flash devices and one for single-level cell NAND flash devices. The two NAND flash controllers use the same pins to interface to external NAND flash devices, so only one interface is active at a time.

#### 7.5.1.1 Multi-Level Cell (MLC) NAND flash controller

The MLC NAND flash controller interfaces to either multi-level or single-level NAND flash devices. An external NAND flash device is used to allow the bootloader to automatically load a portion of the application code into internal SRAM for execution following reset.

The MLC NAND flash controller supports small (528 byte) and large (2114 byte) pages. Programmable NAND timing parameters allow support for a variety of NAND flash devices. A built-in Reed-Solomon encoder/decoder provides error detection and correction capability. A 528 byte data buffer reduces the need for CPU supervision during loading. The MLC NAND flash controller also provides DMA support.

### 7.5.1.2 Single-Level Cell (SLC) NAND flash controller

The SLC NAND flash controller interfaces to single-level NAND flash devices. DMA page transfers are supported, including a 20-byte DMA read and write FIFO. Hardware support for ECC (Error Checking and Correction) is included for the main data area. Software can correct a single bit error.

### 7.5.2 SD card controller

The SD interface allows access to external SD memory cards. The SD card interface conforms to the *SD Memory Card Specification Version 1.01*.

#### 7.5.2.1 Features

- 1-bit and 4-bit data line interface support.
- DMA is supported through the system DMA controller.
- Provides all functions specific to the SD memory card. These include the clock generation unit, power management control, command and data transfer.

### 7.5.3 External memory controller

The LPC3220/30/40/50 includes a memory controller that supports data bus SDRAM, DDR SDRAM, and static memory devices. The memory controller provides an interface between the system bus and external (off-chip) memory devices.

The controller supports 16-bit and 32-bit wide SDR SDRAM devices of 64 Mbit, 128 Mbit, 128 Mbit, 256 Mbit, and 512 Mbit sizes, as well as 16-bit wide data bus DDR SDRAM devices of 64 Mbit, 128 Mbit, 128 Mbit, 256 Mbit, and 512 Mbit sizes. Two dynamic memory chip selects are supplied, supporting two groups of SDRAM:

- DYCS0 in the address range 0x8000 0000 to 0x9FFF FFFF
- DYCS1 in the address range 0xA000 0000 to 0xBFFF FFFF

The memory controller also supports 8-bit, 16-bit, and 32-bit wide asynchronous static memory devices, including RAM, ROM, and flash, with or without asynchronous page mode. Four static memory chip selects are supplied for SRAM devices:

- CS0 in the address range 0xE000 0000 to 0xE0FF FFFF
- CS1 in the address range 0xE100 0000 to 0xE1FF FFFF
- CS2 in the address range 0xE200 0000 to 0xE2FF FFFF
- CS3 in the address range 0xE300 0000 to 0xE3FF FFFF

The SDRAM controller uses three data ports to allow simultaneous requests from multiple on-chip AHB bus masters and has the following features.

- Dynamic memory interface supports SDRAM, DDR-SDRAM, and low-power variants.
- Read and write buffers to reduce latency and improve performance.
- Static memory features include
  - asynchronous page mode read
  - programmable wait states
  - bus turnaround cycles
  - output enable and write enable delays

- extended wait
- Power-saving modes dynamically control EMC\_CKE[1:0] and EMC\_CLK.
- Dynamic memory self-refresh mode supported by software.
- Controller supports 2 k, 4 k, and 8 k row address synchronous memory parts. That is, typical 512 MB, 256 MB, 128 MB, and 16 MB parts, with 8, 16, or 32 data bits per device.
- Two reset domains enable dynamic memory contents to be preserved over a soft reset.
- This controller does not support synchronous static memory devices (burst mode devices).

## 7.6 AHB master peripherals

The LPC3220/30/40/50 implements four AHB master peripherals, which include a General Purpose Direct Memory Access (GPDMA) controller, a 10/100 Ethernet Media Access Controller (MAC), a Universal Serial Bus (USB) controller, and an LCD controller. Each of these four peripherals contain an integral DMA controller optimized to support the performance demands of the peripheral.

### 7.6.1 General Purpose DMA (GPDMA) controller

The GPDMA controller allows peripheral-to memory, memory-to-peripheral, peripheral-to-peripheral, and memory-to-memory transactions. Each DMA stream provides unidirectional serial DMA transfers for a single source and destination. For example, a bidirectional port requires one stream for transmit and one for receive. The source and destination areas can each be either a memory region or a peripheral, and can be accessed through the same AHB master, or one area by each master. The DMA controller supports the following peripheral device transfers.

- Secure Digital (SD) Memory interface
- High-speed UARTs
- I<sup>2</sup>S0 and I<sup>2</sup>S1 ports
- SPI1 and SPI2 interfaces
- SSP0 and SSP1 interfaces
- Memory

The DMA controls eight DMA channels with hardware prioritization. The DMA controller interfaces to the system via two AHB bus masters, each with a full 32-bit data bus width. DMA operations may be set up for 8-bit, 16-bit, and 32-bit data widths, and can be either big-endian or little-endian. Incrementing or non-incrementing addressing for source and destination are supported, as well as programmable DMA burst size. Scatter or gather DMA is supported through the use of linked lists. This means that the source and destination areas do not have to occupy contiguous areas of memory.

### 7.6.2 Ethernet MAC

The Ethernet block contains a full featured 10 Mbit/s or 100 Mbit/s Ethernet MAC designed to provide optimized performance through the use of DMA hardware acceleration. Features include a generous suite of control registers, half or full duplex operation, flow control, control frames, hardware acceleration for transmit retry, receive

packet filtering and wake-up on LAN activity. Automatic frame transmission and reception with scatter-gather DMA off-loads many operations from the CPU. The Ethernet DMA can access off-chip memory via the EMC, as well as the IRAM. The Ethernet block interfaces between an off-chip Ethernet PHY using the Media Independent Interface (MII) or Reduced MII (RMII) protocol and the on-chip Media Independent Interface Management (MIIM) serial bus.

### 7.6.2.1 Features

- Ethernet standards support:
  - Supports 10 Mbit/s or 100 Mbit/s PHY devices including 10 Base-T, 100 Base-TX, 100 Base-FX, and 100 Base-T4.
  - Fully compliant with IEEE standard 802.3.
  - Fully compliant with 802.3x Full Duplex Flow Control and Half Duplex back pressure.
  - Flexible transmit and receive frame options.
  - Virtual Local Area Network (VLAN) frame support.
- Memory management:
  - Independent transmit and receive buffers memory mapped to SRAM.
  - DMA managers with scatter/gather DMA and arrays of frame descriptors.
  - Memory traffic optimized by buffering and pre-fetching.
- Enhanced Ethernet features:
  - Receive filtering.
  - Multicast and broadcast frame support for both transmit and receive.
  - Optional automatic Frame Check Sequence (FCS) insertion with Circular Redundancy Check (CRC) for transmit.
  - Selectable automatic transmit frame padding.
  - Over-length frame support for both transmit and receive allows any length frames.
  - Promiscuous receive mode.
  - Automatic collision back-off and frame retransmission.
  - Includes power management by clock switching. Wake-on-LAN power management support allows system wake-up using the receive filters or a magic frame detection filter.
- Physical interface
  - Attachment of external PHY chip through standard MII or RMII interface.
  - PHY register access is available via the MIIM interface.

### 7.6.3 USB interface

The LPC3220/30/40/50 supports USB in either device, host, or OTG configuration.

#### 7.6.3.1 USB device controller

The USB device controller enables 12 Mbit/s data exchange with a USB host controller. It consists of register interface, serial interface engine, endpoint buffer memory and DMA controller. The serial interface engine decodes the USB data stream and writes data to the appropriate end point buffer memory. The status of a completed USB transfer or error

condition is indicated via status registers. An interrupt is also generated if enabled. The DMA controller when enabled transfers data between the endpoint buffer and the USB RAM.

### Features

- Fully compliant with *USB 2.0 full-speed specification*.
- Supports 32 physical (16 logical) endpoints.
- Supports control, bulk, interrupt and isochronous endpoints.
- Scalable realization of endpoints at run time.
- Endpoint maximum packet size selection (up to USB maximum specification) by software at run time.
- RAM message buffer size based on endpoint realization and maximum packet size.
- Supports bus-powered capability with low suspend current.
- Supports DMA transfer on all non-control endpoints.
- One duplex DMA channel serves all endpoints.
- Allows dynamic switching between CPU controlled and DMA modes.
- Double buffer implementation for bulk and isochronous endpoints.

#### 7.6.3.2 USB host controller

The host controller enables data exchange with various USB devices attached to the bus. It consists of register interface, serial interface engine and DMA controller. The register interface complies to the *OHCI specification*.

### Features

- OHCI compliant.
- OHCI specifies the operation and interface of the USB host controller and software driver.
- The host controller has four USB states visible to the software driver:
  - USBOperational: Process lists and generate SOF tokens.
  - USBReset: Forces reset signaling on the bus, SOF disabled.
  - USBSuspend: Monitor USB for wake-up activity.
  - USBResume: Forces resume signaling on the bus.
- HCCA register points to interrupt and isochronous descriptors list.
- ControlHeadED and BulkHeadED registers point to control and bulk descriptors list.

#### 7.6.3.3 USB OTG controller

USB OTG (On-The-Go) is a supplement to the *USB 2.0 specification* that augments the capability of existing mobile devices and USB peripherals by adding host functionality for connection to USB peripherals.

### Features

- Fully compliant with *On-The-Go supplement to the USB Specification 2.0 Revision 1.0*.



- Supports Host Negotiation Protocol (HNP) and Session Request Protocol (SRP) for dual-role devices under software control. HNP is partially implemented in hardware.
- Provides programmable timers required for HNP and SRP.
- Supports slave mode operation through AHB slave interface.
- Supports the OTG ATX from NXP (ISP 1302) or any external CEA-2011OTG specification compliant ATX.

#### 7.6.4 LCD controller

The LCD controller provides all of the necessary control signals to interface directly to a variety of color and monochrome LCD panels. Both STN (single and dual panel) and TFT panels can be operated. The display resolution is selectable and can be up to 1024 × 768 pixels. Several color modes are provided, up to a 24-bit true-color non-palettized mode.

An on-chip 512-byte color palette allows reducing bus utilization (i.e. memory size of the displayed data) while still supporting a large number of colors.

The LCD interface includes its own DMA controller to allow it to operate independently of the CPU and other system functions. A built-in FIFO acts as a buffer for display data, providing flexibility for system timing. Hardware cursor support can further reduce the amount of CPU time needed to operate the display.

##### 7.6.4.1 Features

- AHB bus master interface to access frame buffer.
- Setup and control via a separate AHB slave interface.
- Dual 16-deep programmable 64-bit wide FIFOs for buffering incoming display data.
- Supports single and dual-panel monochrome Super Twisted Nematic (STN) displays with 4-bit or 8-bit interfaces.
- Supports single and dual-panel color STN displays.
- Supports Thin Film Transistor (TFT) color displays.
- Programmable display resolution including, but not limited to: 320 × 200, 320 × 240, 640 × 200, 640 × 240, 640 × 480, 800 × 600, and 1024 × 768.
- Hardware cursor support for single-panel displays.
- 15 gray-level monochrome, 3375 color STN, and 32 k color palettized TFT support.
- 1, 2, or 4 bits-per-pixel (bpp) palettized displays for monochrome STN.
- 1, 2, 4, or 8 bpp palettized color displays for color STN and TFT.
- 16 bpp true-color non-palettized, for color STN and TFT.
- 24 bpp true-color non-palettized, for color TFT.
- Programmable timing for different display panels.
- 256 entry, 16-bit palette RAM, arranged as a 128 × 32 bit RAM.
- Frame, line, and pixel clock signals.
- AC bias signal for STN, data enable signal for TFT panels.
- Supports little and big-endian, and Windows CE data formats.
- LCD panel clock may be generated from the peripheral clock or from a clock input pin.

## 7.7 System functions

To enhance the performance of the LPC3220/30/40/50 incorporates the following system functions, an Interrupt Controller (INTC), a watchdog timer, a millisecond timer, and several power control features. These functions are described in the following sections

### 7.7.1 Interrupt controller

The interrupt controller is comprised of three basic interrupt controller blocks, supporting a total of 73 interrupt sources. Each interrupt source can be individually enabled/disabled and configured for high or low level triggering, or rising or falling edge triggering. Each interrupt may also be steered to either the FIQ or IRQ input of the ARM9. Raw interrupt status and masked interrupt status registers allow versatile condition evaluation. In addition to peripheral functions, each of the six general purpose input/output pins and 12 of the 22 general purpose input pins are connected directly to the interrupt controller.

### 7.7.2 Watchdog timer

The watchdog timer block is clocked by the main peripheral clock, which clocks a 32-bit counter. A match register is compared to the Timer. When configured for watchdog functionality, a match drives the match output low. The match output is gated with an enable signal that gives the opportunity to generate two type of reset signal: one that only resets chip internally, and another that goes through a programmable pulse generator before it goes to the external pin  $\overline{\text{RESOUT}}$  and to the internal chip reset.

#### 7.7.2.1 Features

- Programmable 32-bit timer.
- Internally resets the device if not periodically reloaded.
- Flag to indicate that a watchdog reset has occurred.
- Programmable watchdog pulse output on  $\overline{\text{RESOUT}}$  pin.
- Can be used as a standard timer if watchdog is not used.
- Pause control to stop counting when core is in debug state.

### 7.7.3 Millisecond timer

The millisecond timer is clocked by 32 kHz RTC clock, so a prescaler is not needed to obtain a lower count rate.

The millisecond timer includes three match registers that are compared to the Timer/Counter value. A match can generate an interrupt and the cause the Timer/Counter either continue to run, stop, or be reset.

#### 7.7.3.1 Features

- 32-bit Timer/Counter, running from the 32 kHz RTC clock.
- Counter or Timer operation.
- Three 32-bit match registers that allow:
  - Continuous operation with optional interrupt generation on match.
  - Stop timer on match with optional interrupt generation.
  - Reset timer on match with optional interrupt generation.
- Pause control to stop counting when core is in debug state.

## 7.7.4 Clocking and power control features

### 7.7.4.1 Clocking

Clocking in the LPC3220/30/40/50 is designed to be versatile, so that system and peripheral requirements may be met, while allowing optimization of power consumption. Clocks to most functions may be turned off if not needed and some peripherals do this automatically.

The LPC3220/30/40/50 supports three operational modes, two of which are specifically designed to reduce power consumption. The modes are: Run mode, Direct run mode, and Stop mode. These three operational modes give control over processing speed and power consumption. In addition, clock rates to different functional blocks may be changed by switching clock sources, changing PLL values, or altering clock divider configurations. This allows a trade-off of power versus processing speed based on application requirements.

### 7.7.4.2 Crystal oscillator

The main oscillator is the basis for the clocks most chip functions use by default. Optionally, many functions can be clocked instead by the output of a PLL (with a fixed 397x rate multiplication) which runs from the RTC oscillator. In this mode, the main oscillator may be turned off unless the USB interface is enabled. If a SYSCLK frequency other than 13 MHz is required in the application, or if the USB block is not used, the main oscillator may be used with a frequency of between 1 MHz and 20 MHz.

### 7.7.4.3 PLLs

The LPC3220/30/40/50 includes three PLLs: The 397x PLL allows boosting the RTC frequency to 13.008896 MHz for use as the primary system clock. The USB PLL provides the 48 MHz clock required by the USB block, and the HCLK PLL provides the basis for the CPU clock, the AHB bus clock, and the main peripheral clock.

The 397x PLL multiplies the 32768 Hz RTC clock by 397 to obtain a 13.008896 MHz clock. The 397x PLL is designed for low power operation and low jitter. This PLL requires an external RC loop filter for proper operation.

The HCLK PLL accepts an input clock from either the main oscillator or the output of the 397x PLL. The USB PLL only accepts an input clock from the main oscillator. The USB input clock runs through a divide-by-N pre-divider before entering the USB PLL.

The input to the HCLK and USB PLLs may initially be divided down by a pre-divider value 'N', which may have the values 1, 2, 3, or 4. This pre-divider can allow a greater number of possibilities for the output frequency. Following the PLL input divider is the PLL multiplier. This can multiply the pre-divider output by a value 'M', in the range of 1 through 256. The resulting frequency must be in the range of 156 MHz to 320 MHz. The multiplier works by dividing the output of a Current Controlled Oscillator (CCO) by the value of M, then using a phase detector to compare the divided CCO output to the pre-divider output. The error value is used to adjust the CCO frequency.

At the PLL output, there is a post-divider that can be used to bring the CCO frequency down to the desired PLL output frequency. The post-divider value can divide the CCO output by 1, 2, 4, 8, or 16. The post-divider can also be bypassed, allowing the PLL CCO

output to be used directly. The maximum PLL output frequency supported by the CPU is 266 MHz. The only output frequency supported by the USB PLL is 48 MHz, and the clock has strict requirements for nominal frequency (500 ppm) and jitter (500 ps).

#### 7.7.4.4 Power control modes

The LPC3220/30/40/50 supports three operational modes, two of which are specifically designed to reduce power consumption. The modes are: Run mode, Direct Run mode, and Stop mode.

Run mode is the normal operating mode for applications that require the CPU, AHB bus, or any peripheral function other than the USB block to run faster than the main oscillator frequency. In Run mode, the CPU can run at up to 266 MHz and the AHB bus can run at up to 133 MHz.

Direct Run mode allows reducing the CPU and AHB bus rates in order to save power. Direct Run mode can also be the normal operating mode for applications that do not require the CPU, AHB bus, or any peripheral function other than the USB block to run faster than the main oscillator frequency. Direct Run mode is the default mode following chip reset.

Stop mode causes all CPU and AHB operation to cease, and stops clocks to peripherals other than the USB block.

#### 7.7.4.5 Reset

Reset is accomplished by an active LOW signal on the  $\overline{\text{RESET}}$  input pin. A reset pulse with a minimum width of 10 main oscillator clocks after the oscillator is stable is required to guarantee a valid chip reset. At power-up, 10 milliseconds should be allowed for the oscillator to start up and stabilize after  $V_{DD}$  reaches operational voltage. An internal reset with a minimum duration of 10 clock pulses will also be applied if the watchdog timer generates an internal device reset.

The  $\overline{\text{RESET}}$  pin is located in the RTC power domain. This means that the RTC power must be present for an external reset to have any effect. The RTC power domain nominally runs from 1.2 V, but the  $\overline{\text{RESET}}$  pin can be driven as high as 1.95 V.

## 7.8 Communication peripheral interfaces

In addition to the Ethernet MAC and USB interfaces there are many more serial communication peripheral interfaces available on the LPC3220/30/40/50. Here is a list of the serial communication interfaces:

- Seven UARTs; four standard UARTs and three high-speed UARTs
- Two SPI serial I/O controllers
- Two SSP serial I/O controllers
- Two I<sup>2</sup>C serial I/O controllers
- Two I<sup>2</sup>S audio controllers

A short functional description of each of these peripherals is provided in the following sections.

### 7.8.1 UARTs

The LPC3220/30/40/50 contains seven UARTs. Four are standard UARTs, and three are high-speed UARTs.

#### 7.8.1.1 Standard UARTs

The four standard UARTs are compatible with the INS16Cx50. These UARTs support rates up to 460800 bit/s from a 13 MHz peripheral clock.

##### Features

- Each standard UART has 64 byte Receive and Transmit FIFOs.
- Receiver FIFO trigger points at 16, 32, 48, and 60 Bytes.
- Transmitter FIFO trigger points at 0, 4, 8, and 16 Bytes.
- Register locations conform to the “550” industry standard.
- Each standard UART has a fractional rate pre-divider and an internal baud rate generator.
- The standard UARTs support three clocking modes: on, off, and auto-clock. The auto-clock mode shuts off the clock to the UART when it is idle.
- UART 6 includes an IrDA mode to support infrared communication.
- The standard UARTs are designed to support data rates of (2400, 4800, 9600, 19200, 38400, 57600, 115200, 230400, 460800) bit/s.
- Each UART includes an internal loopback mode.

#### 7.8.1.2 High-speed UARTs

The three high-speed UARTs are designed to support rates up to 921600 bit/s from a 13 MHz peripheral clock for on-board communication in low noise conditions. This is accomplished by changing the over sampling from 16× to 14× and altering the rate generation logic.

##### Features

- Each high-speed UART has 64-byte Receive and Transmit FIFOs.
- Receiver FIFO trigger points at 1, 4, 8, 16, 32, and 48 B.
- Transmitter FIFO trigger points at 0, 4, and 8 B.
- Each high-speed UART has an internal baud rate generator.
- The high-speed UARTs are designed to support data rates of (2400, 4800, 9600, 19200, 38400, 57600, 115200, 230400, 460800, 921600) bit/s.
- The three high speed UARTs only support (8N1) 8-bit data word length, 1-stop bit, no parity, and no flow control as a the communications protocol.
- Each UART includes an internal loopback mode.

### 7.8.2 SPI serial I/O controller

The LPC3220/30/40/50 has two Serial Peripheral Interfaces (SPI). The SPI is a 3-wire serial interface that is able to interface with a large range of serial peripheral or memory devices (SPI mode 0 to 3 compatible slave devices).

Only a single master and a single slave can communicate on the interface during a given data transfer. During a data transfer the master always sends a byte of data to the slave, and the slave always sends a byte of data to the master. The SPI implementation on the LPC3220/30/40/50 does not support operation as a slave.

### 7.8.2.1 Features

- Supports slaves compatible with SPI modes 0 to 3.
- Half duplex synchronous transfers.
- DMA support for data transmit and receive.
- 1-bit to 16-bit word length.
- Choice of LSB or MSB first data transmission.
- 64 × 16-bit input or output FIFO.
- Bit rates up to 52 Mbit/s.
- Busy input function.
- DMA time out interrupt to allow detection of end of reception when using DMA.
- Timed interrupt to facilitate emptying the FIFO at the end of a transmission.
- SPI clock and data pins may be used as general purpose pins if the SPI is not used.
- Slave selects can be supported using GPO or GPIO pins

### 7.8.3 SSP serial I/O controller

The LPC3220/30/40/50 contains two SSP controllers. The SSP controller is capable of operation on a SPI, 4-wire SSI, or Microwire bus. It can interact with multiple masters and slaves on the bus. Only a single master and a single slave can communicate on the bus during a given data transfer. The SSP supports full duplex transfers, with frames of 4 bits to 16 bits of data flowing from the master to the slave and from the slave to the master. In practice, often only one of these data flows carries meaningful data.

#### 7.8.3.1 Features

- Compatible with Motorola SPI, 4-wire TI SSI, and National Semiconductor Microwire buses
- Synchronous serial communication
- Master or slave operation
- 8-frame FIFOs for both transmit and receive
- 4-bit to 16-bit frame
- Maximum SPI bus data bit rate of  $\frac{1}{2}$  (Master mode) and  $\frac{1}{2}$  (Slave mode) of the input clock rate
- DMA transfers supported by GPDMA

### 7.8.4 I<sup>2</sup>C-bus serial I/O controller

There are two I<sup>2</sup>C-bus interfaces in the LPC32x0 family of controllers. These I<sup>2</sup>C blocks can be configured as a master, multi-master or slave supporting up to 400 kHz. The I<sup>2</sup>C blocks also support 7 or 10 bit addressing. Each has a four word FIFO for both transmit and receive. An interrupt signal is available from each block.

There is a separate slave transmit FIFO. The slave transmit FIFO (TXS) and its level are only available when the controller is configured as a Master/Slave device and is operating in a multi-master environment. Separate TX FIFOs are needed in a multi-master because a controller might have a message queued for transmission when an external master addresses it to become a slave-transmitter, a second source of data is needed.

Note that the I<sup>2</sup>C clock must be enabled in the I2CCLK\_CTRL register before using the I<sup>2</sup>C. The I<sup>2</sup>C clock can be disabled between communications, if used as a single master I<sup>2</sup>C-bus interface, software has full control of when I<sup>2</sup>C communication is taking place on the bus.

#### 7.8.4.1 Features

- The two I<sup>2</sup>C-bus blocks are standard I<sup>2</sup>C-bus compliant interfaces that may be used in Single-master, Multi-master or Slave modes.
- Programmable clock to allow adjustment of I<sup>2</sup>C-bus transfer rates.
- Bidirectional data transfer.
- Serial clock synchronization allows devices with different bit rates to communicate via one serial bus.
- Serial clock synchronization can be used as a handshake mechanism to suspend and resume serial transfer.

#### 7.8.5 I<sup>2</sup>S-bus audio controller

The I<sup>2</sup>S-bus provides a standard communication interface for digital audio applications. The I<sup>2</sup>S-bus specification defines a 3-wire serial bus using one data line, one clock line, and one word select signal. Each I<sup>2</sup>S connection can act as a master or a slave. The master connection determines the frequency of the clock line and all other slaves are driven by this clock source. The two I<sup>2</sup>S-bus interfaces on the LPC3220/30/40/50 provides a separate transmit and receive channel, providing a total of two transmit channels and two receive channels. Each I<sup>2</sup>S channel supports monaural or stereo formatted data.

#### 7.8.5.1 Features

- The interface has separate input/output channels each of which can operate in master or slave mode.
- Capable of handling 8-bit, 16-bit, and 32-bit word sizes.
- Mono and stereo audio data supported.
- Supports standard sampling frequencies (8 kHz, 11.025 kHz, 16 kHz, 22.05 kHz, 32 kHz, 44.1 kHz, 48 kHz, 96 kHz).
- Word select period can be configured in master mode (separately for I<sup>2</sup>S input and output).
- Two eight-word FIFO data buffers are provided, one for transmit and one for receive.
- Generates interrupt requests when buffer levels cross a programmable boundary.
- Two DMA requests, controlled by programmable buffer levels. These are connected to the GPDMA block.
- Controls include reset, stop, and mute options separately for I<sup>2</sup>S input and I<sup>2</sup>S output.



## 7.9 Other peripherals

In addition to the communication peripherals there are many general purpose peripherals available in the LPC3220/30/40/50. Here is a list of the general purpose peripherals.

- GPIO
- Keyboard scanner
- Touch screen controller and 10-bit Analog-to-Digital-Converter
- Real-time clock
- High-speed timer
- Four general purpose 32-bit timer/external event counters
- Two simple PWMs
- One motor control PWM

A short functional description of each of these peripherals is provided in the following sections.

### 7.9.1 General purpose parallel I/O

Some device pins that are not dedicated to a specific peripheral function have been designed to be general purpose inputs, outputs, or input/outputs. Also, some pins may be configured either as a specific peripheral function or a general purpose input, output, or input/output. A total of 51 pins can potentially be used as general purpose input/outputs, 24 as general purpose outputs, and 22 as general purpose inputs.

GPIO pins may be dynamically configured as inputs or outputs. Separate registers allow setting or clearing any number of GPIO and GPO outputs controlled by that register simultaneously. The value of the output register for standard GPIOs and GPO pins may be read back, as well as the current actual state of the port pins.

In addition to GPIO pins on port 0, port 1, and port 2, there are 22 GPI, 24 GPO, and six GPIO pins. When the SDRAM bus is configured for 16 data bits, 13 of the remaining SDRAM data pins may be used as GPIOs.

#### 7.9.1.1 Features

- Bit-level set and clear registers allow a single instruction set or clear of any number of bits in one port.
- A single register selects direction for pins that support both input and output modes.
- Direction control of individual bits.
- For input/output pins, both the programmed output state and the actual pin state can be read.
- There are a total of 12 general purpose inputs, 24 general purpose outputs, and six general purpose input/outputs.
- Additionally, 13 SDRAM data lines may be used as GPIOs if a 16-bit SDRAM interface is used (rather than a 32-bit interface).



## 7.9.2 Keyboard scanner

The keyboard scanner function can automatically scan a keyboard of up to 64 keys in an  $8 \times 8$  matrix. In operation, the keyboard scanner's internal state machine will normally be in an idle state, with all KEY\_ROWn pins set high, waiting for a change in the column inputs to indicate that one or more keys have been pressed.

When a keypress is detected, the matrix is scanned by setting one output pin high at a time and reading the column inputs. After de-bouncing, the keypad state is stored and an interrupt is generated. The keypad is then continuously scanned waiting for 'extra key pressed' or 'key released'. Any new keypad state is scanned and stored into the matrix registers followed by a new interrupt request to the interrupt controller. It is possible to detect and separate up to 64 multiple keys pressed.

### 7.9.2.1 Features

- Supports up to 64 keys in  $8 \times 8$  matrix.
- Programmable de-bounce period.
- A key press can wake up the CPU from Stop mode.

## 7.9.3 Touch screen controller and 10-bit ADC

The LPC3220/30/40/50 microcontrollers includes Touch Screen Controller (TSC) hardware, which automatically measures and determines the X and Y coordinates where a touch screen is pressed. In addition, the TSC can measure an analog input signal on the AUX\_IN pin.

Optionally, the TSC can operate as an Analog-to-Digital Converter (ADC). The ADC supports three channels and uses 10-bit successive approximation to produce results with a resolution of 10 bits in 11 clock cycles.

The analog portion of the ADC has its own power supply to enhance the low noise characteristics of the converter. This voltage is only supplied internally when the core has voltage. However, the ADC block is not affected by any difference in ramp-up time for VDD\_AD and VDD\_CORE voltage supplies.

### 7.9.3.1 Features

- Measurement range of 0 V to VDD\_AD (nominally 3.3 V).
- Low-noise ADC.
- 10-bit resolution.
- Three input channels.
- Uses 32 kHz RTC clock or peripheral clock.

## 7.9.4 Real-Time Clock (RTC) and battery RAM

The RTC runs at 32768 Hz using a very low power oscillator. The RTC counts seconds and can generate alarm interrupts that can wake up the device from Stop mode. The RTC clock can also clock the 397x PLL, the Millisecond Timer, the ADC, the Keyboard Scanner and the PWMs. The RTC up-counter value represents a number of seconds elapsed since second 0, which is an application determined time. The RTC counter will reach maximum value after about 136 years. The RTC down-counter is initiated with all ones.

Two 32-bit match registers are readable and writable by the processor. A match will result in an interrupt provided that the interrupt is enabled. The ONSW output pin can also be triggered by a match event and cause an external power supply to turn on all of the operating voltages, as a way to startup after power has been removed.

The RTC block is implemented in a separate voltage domain. The block is supplied via a separate supply pin from a battery or other power source.

The RTC block also contains 32 words (128 bytes) of very low voltage SRAM. This SRAM is able to hold its contents down to the minimum RTC operating voltage.

#### 7.9.4.1 Features

- Measures the passage of time in seconds.
- 32-bit up and down seconds counters.
- Ultra-low power design to support battery powered systems.
- Dedicated 32 kHz oscillator.
- An output pin is included to assist in waking up when the chip has had power removed to all functions except the RTC.
- Two 32-bit match registers with interrupt option.
- 32 words (128 bytes) of very low voltage SRAM.
- The RTC and battery RAM power have an independent power domain and dedicated supply pins, which can be powered from a battery or power supply.

**Remark:** The LPC3220/30/40/50 will run at voltages down to 0.9 V at frequencies below 14 MHz. However, the ARM core cannot access the RTC registers and battery RAM when the core supply voltage is at 0.9 V and the RTC supply is at 1.2 V.

#### 7.9.5 Enhanced 32-bit timers/external event counters

The LPC3220/30/40/50 includes six 32-bit Timer/Counters. The Timer/Counter is designed to count cycles of the system derived clock or an externally-supplied clock. It can optionally generate interrupts or perform other actions at specified timer values, based on four match registers. The Timer/Counter also includes four capture inputs to trap the timer value when an input signal transitions, optionally generating an interrupt.

##### 7.9.5.1 Features

- A 32-bit Timer/Counter with a programmable 32-bit pre-scaler.
- Counter or Timer operation.
- Up to four 32-bit capture channels per timer, that can take a snapshot of the timer value when an input signal transitions. A capture event may also optionally generate an interrupt.
- Four 32-bit match registers that allow:
  - continuous operation with optional interrupt generation on match
  - stop timer on match with optional interrupt generation
  - reset timer on match with optional interrupt generation
- Up to four external outputs corresponding to match registers, with the following capabilities:

- set LOW on match
- set HIGH on match
- toggle on match
- do nothing on match

### 7.9.6 High-speed timer

The high-speed timer block is clocked by the main peripheral clock. The clock is first divided down in a 16-bit programmable pre-scale counter which clocks a 32-bit timer/counter.

The high-speed timer includes three match registers that are compared to the timer/counter value. A match can generate an interrupt and cause the timer/counter to either continue to run, stop, or be reset. The high-speed timer also includes two capture registers that can take a snapshot of the timer/counter value when an input signal transitions. A capture event may also generate an interrupt.

#### 7.9.6.1 Features

- 32-bit timer/counter with programmable 16-bit pre-scaler.
- Counter or timer operation.
- Two 32-bit capture registers.
- Three 32-bit match registers that allow:
  - Continuous operation with optional interrupt generation on match.
  - Stop timer on match with optional interrupt generation.
  - Reset timer on match with optional interrupt generation.
- Pause control to stop counting when core is in debug state.

### 7.9.7 Pulse Width Modulators (PWMs)

The LPC3220/30/40/50 provides two simple PWMs. They are clocked separately by either the main peripheral clock or the 32 kHz RTC clock. Both PWMs have a duty cycle programmable in 255 steps.

#### 7.9.7.1 Features

- Clocked by the main peripheral clock or the 32 kHz RTC clock.
- Programmable 4-bit pre-scaler.
- Duty cycle programmable in 255 steps.
- Output frequency up to 50 kHz when using a 13 MHz peripheral clock.

### 7.9.8 Motor control pulse width modulator

The Motor Control PWM (MCPWM) provides a set of features for three-phase AC and DC motor control applications in a single peripheral. The MCPWM can also be configured for use in other generalized timing, counting, capture, and compare applications.

#### 7.9.8.1 Features

- 32-bit timer
- 32-bit period register

- 32-bit pulse-width (match) register
- 10-bit dead-time register and an associated 10-bit dead-time counter
- 32-bit capture register
- Two PWM (match) outputs (pins MCOA0/1/2 and MCOB0/1/2) with opposite polarities
- Period interrupt, pulse-width interrupt, and capture interrupt

## 8. Basic architecture

The LPC3220/30/40/50 is a general purpose ARM926EJ-S 32-bit microprocessor with a 32 kB instruction cache and a 32 kB data cache. The microcontroller offers high performance and very low power consumption. The ARM architecture is based on RISC principles, which results in the instruction set and related decode mechanism being much simpler than equivalent micro programmed CISCs. This simplicity results in a high instruction throughput and impressive real-time interrupt response from a small and cost-effective processor core.

The ARM926EJ-S core employs a 5-stage pipeline so processing and memory system accesses can occur continuously. At any one point in time, several operations are in progress: subsequent instruction fetch, next instruction decode, instruction execution, memory access, and write-back. The combination of architectural enhancements gives the ARM9 about 30 % better performance than an ARM7 running at the same clock rate:

- Approximately 1.3 clocks per instruction for the ARM926EJ-S compared to 1.9 clocks per instruction for ARM7TDMI.
- Approximately 1.1 Dhrystone MIPS/MHz for the ARM926EJ-S compared to 0.9 Dhrystone MIPS/MHz for ARM7TDMI.

The ARM926EJ-S processor also employs an operational state known as Thumb, which makes it ideally suited to high-volume applications with memory restrictions, or applications where code density is an issue.

The key idea behind Thumb state is the use of a super-reduced instruction set. Essentially, the ARM926EJ-S processor core has two instruction sets:

1. The standard 32-bit ARM set
2. The 16-bit Thumb set

The Thumb set's smaller 16-bit instruction length allows it to approach twice the density of standard ARM code while retaining many of ARM's 32-bit performance advantage over a traditional 16-bit processor using 16-bit registers. This is possible because Thumb code operates using the same 32-bit register set as ARM code. Thumb code size is up to 65 % smaller than ARM code size, and 160 % of the performance of an equivalent ARM processor connected to a 16-bit memory system. Additionally, the ARM926EJ-S core includes enhanced DSP instructions and multiplier, as well as an enhanced 32-bit MAC block.

## 9. Limiting values

**Table 7. Limiting values**

In accordance with the Absolute Maximum Rating System (IEC 60134).<sup>[1]</sup>

Symbol	Parameter	Conditions	Notes	Min	Max	Unit
V <sub>DD(1V2)</sub>	supply voltage (1.2 V)		[2]	-0.5	+1.4	V
V <sub>DD(EMC)</sub>	external memory controller supply voltage		[3]	-0.5	+4.6	V
V <sub>DDA(3V3)</sub>	analog supply voltage (3.3 V)		[4]	-0.5	+4.6	V
V <sub>DD(IO)</sub>	input/output supply voltage		[5]	-0.5	+4.6	V
V <sub>IA</sub>	analog input voltage			-0.5	+4.6	V
V <sub>I</sub>	input voltage	1.8 V pins	[6]	-0.5	+2.4	V
		3.3 V pins	[6]	-0.5	+4.6	V
I <sub>DD</sub>	supply current	per supply pin		-	100	mA
I <sub>SS</sub>	ground current	per ground pin		-	100	mA
T <sub>stg</sub>	storage temperature			-65	+150	°C
P <sub>tot(pack)</sub>	total power dissipation (per package)	max. junction temp 125 °C max. ambient temp 85 °C	[7]	-	1.12	W
V <sub>ESD</sub>	electrostatic discharge voltage	HBM	[8]	-	2500	V
		CDM	[9]	-	1000	V

[1] The following applies to [Table 7](#):

- a) This product includes circuitry specifically designed for the protection of its internal devices from the damaging effects of excessive static charge. Nonetheless, it is suggested that conventional precautions be taken to avoid applying greater than the rated maximum.
  - b) Parameters are valid over operating temperature range unless otherwise specified. All voltages are with respect to V<sub>SS</sub> unless otherwise noted.
- [2] Core, PLL, oscillator, and RTC supplies; applies to pins VDD\_CORE, VDD\_COREFXD, VDD\_OSC, VDD\_PLL397, VDD\_PLLHCLK, VDD\_PLLUSB, VDD\_RTC, VDD\_RTCCORE, and VDD\_RTCOSC.
- [3] I/O pad supply; applies to domains VDD\_EMC.
- [4] Applies to VDD\_AD pins.
- [5] Applies to pins in the following domains VDD\_IOA, VDD\_IOB, VDD\_IOC, and VDD\_IOD.
- [6] Including voltage on outputs in 3-state mode.
- [7] Based on package heat transfer, not device power consumption. Calculated package thermal resistance (Theta<sub>JA</sub>): 35.766 °C/W (with JEDEC Test Board and 0 m/s airflow, ±15 % accuracy).
- [8] Human body model: equivalent to discharging a 100 pF capacitor through a 1.5 kΩ series resistor.
- [9] Charge device model per AEC-Q100-011.

## 10. Static characteristics

**Table 8. Static characteristics**

$T_{amb} = -40\text{ }^{\circ}\text{C}$  to  $+85\text{ }^{\circ}\text{C}$ , unless otherwise specified.

Symbol	Parameter	Conditions		Min	Typ <sup>[1]</sup>	Max	Unit
V <sub>DD(1V2)</sub>	supply voltage (1.2 V)	core supply voltage for full performance; 266 MHz (see Figure 4); VDD_CORE supply domain	[2]	1.31	1.35	1.39	V
		core supply voltage for normal performance; 208 MHz (see Figure 4); VDD_CORE supply domain	[2]	1.1	1.2	1.39	V
		core supply voltage for reduced power; up to 14 MHz CPU; VDD_CORE supply domain	[2]	0.9	-	1.39	V
		RTC supply voltage; VDD_RTC supply domain	[3]	0.9	-	1.39	V
		PLL and oscillator supply voltage	[4]	1.1	1.2	1.39	V
V <sub>DD(EMC)</sub>	external memory controller supply voltage	in 1.8 V range	[5]	1.7	1.8	1.95	V
		in 2.5 V range	[6]	2.3	2.5	2.7	V
		in 3.3 V range	[7]	2.7	3.3	3.6	V
V <sub>DD(IO)</sub>	input/output supply voltage	VDD_IOA, VDD_IOB, and VDD_IOD supply domain in 1.8 V range		1.7	1.8	1.95	V
		in 3.3 V range		2.7	3.3	3.6	V
		VDD_IOC supply domain in 1.8 V range		1.7	1.8	1.95	V
		in 3.3 V range		2.3	3.3	3.6	V
V <sub>DDA(3V3)</sub>	analog supply voltage (3.3 V)	applies to pins in VDD_AD power domain		2.7	3.3	3.6	V

**Table 8. Static characteristics ...continued**  
*T<sub>amb</sub> = -40 °C to +85 °C, unless otherwise specified.*

Symbol	Parameter	Conditions	Min	Typ <sup>[1]</sup>	Max	Unit
<b>Power consumption in Run, direct Run, and Stop modes</b>						
I <sub>DD(run)</sub>	Run mode supply current	T <sub>amb</sub> = 25 °C; code <code>while(1){}</code> executed from IRAM; all peripherals enabled				
		I-cache/D-cache, MMU enabled; CPU clock = 208 MHz; VDD_CORE = 1.2 V	-	150	-	mA
		I-cache/D-cache, MMU enabled; CPU clock = 266 MHz; VDD_CORE = 1.35 V	-	218	-	mA
		I-cache/D-cache, MMU disabled; CPU clock = 208 MHz; VDD_CORE = 1.2 V	-	78	-	mA
		I-cache/D-cache, MMU disabled; CPU clock = 266 MHz; VDD_CORE = 1.35 V	-	111	-	mA
I <sub>DD(drun)</sub>	direct Run mode supply current	T <sub>amb</sub> = 25 °C; CPU clock = 13 MHz; code <code>while(1){}</code> executed from IRAM; all peripherals disabled				
		I-cache/D-cache, MMU enabled; VDD_CORE = 1.2 V	-	7.8	-	mA
		I-cache/D-cache, MMU enabled; VDD_CORE = 0.9 V	-	5.6	-	mA
		I-cache/D-cache, MMU disabled; VDD_CORE = 1.2 V	-	5	-	mA
		I-cache/D-cache, MMU disabled; VDD_CORE = 0.9 V	-	3.5	-	mA
I <sub>DD(stop)</sub>	Stop mode supply current	T <sub>amb</sub> = 25 °C; CPU clock stopped internally; all peripherals disabled				
		VDD_CORE = 1.2 V	-	400	-	μA
		VDD_CORE = 0.9 V	-	400	-	μA

**Table 8. Static characteristics ...continued**  
*T<sub>amb</sub> = -40 °C to +85 °C, unless otherwise specified.*

Symbol	Parameter	Conditions	Min	Typ <sup>[1]</sup>	Max	Unit	
I <sub>DD(RTC)</sub>	RTC supply current	normal operation; VDD_RTC = VDD_RTCCORE = VDD_RTCOSC = 1.2 V; T <sub>amb</sub> = 25 °C	[8]	-	13	-	μA
		RTC back up operation; Rev “-” silicon	[9]	-	30	-	μA
		Rev “A” silicon	[9]	-	4	-	
I <sub>DD</sub>	supply current	for HCLK; PLL output frequency = 266 MHz; VDD_PLLHCLK = 1.2 V		-	2	-	mA
		for USB; VDD_PLLUSB = 1.2 V		-	2	-	mA
		for ADC; interrupt driven loop converting ADIN[2:0]; VDD_AD = 3.3 V		-	< 1	-	mA
<b>Input pins and I/O pins configured as input</b>							
V <sub>I</sub>	input voltage		[10][12]	0	-	V <sub>DD(IO)</sub>	V
V <sub>IH</sub>	HIGH-level input voltage	1.8 V inputs		0.7 × V <sub>DD(IO)</sub>	-	-	V
		3.3 V inputs		0.7 × V <sub>DD(IO)</sub>	-	-	V
V <sub>IL</sub>	LOW-level input voltage	1.8 V inputs		-	-	0.3 × V <sub>DD(IO)</sub>	V
		3.3 V inputs		-	-	0.3 × V <sub>DD(IO)</sub>	V
V <sub>hys</sub>	hysteresis voltage	1.8 V inputs		0.1 × V <sub>DD(IO)</sub>	-	-	V
		3.3 V inputs		0.1 × V <sub>DD(IO)</sub>	-	-	V
I <sub>IL</sub>	LOW-level input current	V <sub>I</sub> = 0 V; no pull-up		-	-	1	μA
I <sub>IH</sub>	HIGH-level input current	V <sub>I</sub> = V <sub>DD(IO)</sub> ; no pull-down	[10]	-	-	1	μA
I <sub>latch</sub>	I/O latch-up current	-(1.5V <sub>DD(IO)</sub> ) < V <sub>I</sub> < (1.5V <sub>DD(IO)</sub> )	[10]	-	-	100	mA
I <sub>pu</sub>	pull-up current	1.8 V inputs with pull-up; V <sub>I</sub> = 0 V		6	12	22	μA
		3.3 V inputs with pull-up; V <sub>I</sub> = 0 V		25	50	80	μA
I <sub>pd</sub>	pull-down current	1.8 V inputs with pull-down; V <sub>I</sub> = V <sub>DD(IO)</sub>		5	12	22	μA
		3.3 V inputs with pull-down; V <sub>I</sub> = V <sub>DD(IO)</sub>		25	50	85	μA
I <sub>I</sub>	input current	bus keeper inputs; V <sub>I</sub> = V <sub>DD</sub>		-	-	1	μA
		V <sub>I</sub> = 0.67 × V <sub>DD</sub>		-	-	55	μA
		V <sub>I</sub> = 0.33 × V <sub>DD</sub>		-	-	60	μA
		V <sub>I</sub> = 0 V		-	-	1	μA
C <sub>i</sub>	input capacitance	Excluding bonding pad capacitance		-	-	3.3	pF



**Table 8. Static characteristics ...continued**  
*T<sub>amb</sub> = -40 °C to +85 °C, unless otherwise specified.*

Symbol	Parameter	Conditions	Min	Typ <sup>[1]</sup>	Max	Unit
<b>Output pins and I/O pins configured as output</b>						
V <sub>O</sub>	output voltage		[10][11] [12][13] 0	-	V <sub>DD(IO)</sub>	V
V <sub>OH</sub>	HIGH-level output voltage	1.8 V outputs; I <sub>OH</sub> = -1 mA	[14] V <sub>DD(IO)</sub> - 0.4	-	-	V
		3.3 V outputs; I <sub>OH</sub> = -4 mA	[14] V <sub>DD(IO)</sub> - 0.4	-	-	V
V <sub>OL</sub>	LOW-level output voltage	1.8 V outputs; I <sub>OL</sub> = 4 mA	[14] -	-	0.4	V
		3.3 V outputs; I <sub>OL</sub> = 4 mA	[14] -	-	0.4	V
I <sub>OH</sub>	HIGH-level output current	V <sub>DD(IO)</sub> = 1.8 V; V <sub>OH</sub> = V <sub>DD(IO)</sub> - 0.4 V	[10][14] -3.3	-	-	mA
		V <sub>DD(IO)</sub> = 3.3 V; V <sub>OH</sub> = V <sub>DD(IO)</sub> - 0.4 V	-6.5	-	-	mA
I <sub>OL</sub>	LOW-level output current	V <sub>DD(IO)</sub> = 1.8 V; V <sub>OL</sub> = 0.4 V	[10][14] 1.5	-	-	mA
		V <sub>DD(IO)</sub> = 3.3 V; V <sub>OL</sub> = 0.4 V	3	-	-	mA
I <sub>OZ</sub>	OFF-state output current	V <sub>O</sub> = 0 V; V <sub>O</sub> = V <sub>DD(IO)</sub> ; no pull-up/down	[10] -	-	1	μA
I <sub>OHS</sub>	HIGH-level short-circuit output current	V <sub>DD(IO)</sub> = 1.8 V; V <sub>OH</sub> = 0 V	[15] -	-	66	mA
		V <sub>DD(IO)</sub> = 3.3 V; V <sub>OH</sub> = 0 V	-	-	183	mA
I <sub>OLS</sub>	LOW-level short-circuit output current	V <sub>DD(IO)</sub> = 1.8 V; V <sub>OL</sub> = V <sub>DD(IO)</sub>	[10][15] -	-	34	mA
		V <sub>DD(IO)</sub> = 3.3 V; V <sub>OL</sub> = V <sub>DD(IO)</sub>	-	-	105	mA
Z <sub>O</sub>	output impedance	V <sub>DD(IO)</sub> = 1.8 V	40	-	60	Ω
		V <sub>DD(IO)</sub> = 3.3 V	40	-	60	Ω
<b>EMC pins</b>						
V <sub>I</sub>	input voltage		[12] 0	-	V <sub>DD(EMC)</sub>	V
V <sub>IH</sub>	HIGH-level input voltage	1.8 V inputs	0.7 × V <sub>DD(EMC)</sub>	-	-	V
		3.3 V inputs	0.7 × V <sub>DD(EMC)</sub>	-	-	V
V <sub>IL</sub>	LOW-level input voltage	1.8 V inputs	-	-	0.3 × V <sub>DD(EMC)</sub>	V
		3.3 V inputs	-	-	0.3 × V <sub>DD(EMC)</sub>	V
V <sub>hys</sub>	hysteresis voltage	1.8 V inputs	0.4	-	0.6	V
		3.3 V inputs	0.55	-	0.85	V
I <sub>IL</sub>	LOW-level input current	V <sub>I</sub> = 0 V; no pull-up	-	-	0.3	μA
I <sub>IH</sub>	HIGH-level input current	V <sub>I</sub> = V <sub>DD(EMC)</sub> ; no pull-down	-	-	0.3	μA
I <sub>latch</sub>	I/O latch-up current	-(1.5V <sub>DD(EMC)</sub> ) < V <sub>I</sub> < (1.5V <sub>DD(EMC)</sub> )	-	-	100	mA
I <sub>pu</sub>	pull-up current	1.8 V inputs with pull-up; V <sub>I</sub> = 0	34	62	107	μA
		3.3 V inputs with pull-up; V <sub>I</sub> = 0	97	169	271	μA

**Table 8. Static characteristics ...continued**  
*T<sub>amb</sub> = -40 °C to +85 °C, unless otherwise specified.*

Symbol	Parameter	Conditions		Min	Typ <sup>[1]</sup>	Max	Unit
I <sub>pd</sub>	pull-down current	1.8 V inputs with pull-down; V <sub>I</sub> = V <sub>DD(EMC)</sub>		23	51	93	μA
		3.3 V inputs with pull-down; V <sub>I</sub> = V <sub>DD(EMC)</sub>		73	155	266	μA
C <sub>i</sub>	input capacitance	Excluding bonding pad capacitance		-	-	2.1	pF
V <sub>O</sub>	output voltage		[11] [12][13]	0	-	V <sub>DD(EMC)</sub>	V
V <sub>OH</sub>	HIGH-level output voltage	1.8 V outputs; I <sub>OH</sub> = -1 mA	[14]	V <sub>DD(EMC)</sub> - 0.3	-	-	V
		3.3 V outputs; I <sub>OH</sub> = -4 mA	[14]	V <sub>DD(EMC)</sub> - 0.3	-	-	V
V <sub>OL</sub>	LOW-level output voltage	1.8 V outputs; I <sub>OL</sub> = 4 mA	[14]	-	-	0.3	V
		3.3 V outputs; I <sub>OL</sub> = 4 mA	[14]	-	-	0.3	V
I <sub>OH</sub>	HIGH-level output current	V <sub>DD(EMC)</sub> = 1.8 V; V <sub>OH</sub> = V <sub>DD(EMC)</sub> - 0.4 V	[14]	-6	-	-	mA
		V <sub>DD(EMC)</sub> = 3.3 V; V <sub>OH</sub> = V <sub>DD(EMC)</sub> - 0.4 V		-6	-	-	mA
I <sub>OL</sub>	LOW-level output current	V <sub>DD(EMC)</sub> = 1.8 V; V <sub>OL</sub> = 0.4 V	[14]	6	-	-	mA
		V <sub>DD(EMC)</sub> = 3.3 V; V <sub>OL</sub> = 0.4 V		6	-	-	mA
I <sub>OZ</sub>	OFF-state output current	V <sub>O</sub> = 0 V; V <sub>O</sub> = V <sub>DD(EMC)</sub> ; no pull-up/down		-	-	0.3	μA
I <sub>OHS</sub>	HIGH-level short-circuit output current	V <sub>DD(EMC)</sub> = 1.8 V; V <sub>OH</sub> = 0 V	[15]	-	-	-49	mA
		V <sub>DD(EMC)</sub> = 3.3 V; V <sub>OH</sub> = 0 V		-	-	-81	mA
I <sub>OLS</sub>	LOW-level short-circuit output current	V <sub>DD(EMC)</sub> = 1.8 V; V <sub>OL</sub> = V <sub>DD(EMC)</sub>	[14]	-	-	49	mA
		V <sub>DD(EMC)</sub> = 3.3 V; V <sub>OL</sub> = V <sub>DD(EMC)</sub>		-	-	86	mA
Z <sub>o</sub>	output impedance	V <sub>DD(EMC)</sub> = 1.8 V		35	40	58	Ω
		V <sub>DD(EMC)</sub> = 3.3 V		32	35	45	Ω
<b>I<sup>2</sup>C pins</b>							
V <sub>I</sub>	input voltage		[10] [12]	0	-	5.5	V
V <sub>IH</sub>	HIGH-level input voltage	1.8 V inputs		0.7 × V <sub>DD(IO)</sub>	-	-	V
		3.3 V inputs		0.7 × V <sub>DD(IO)</sub>	-	-	V
V <sub>IL</sub>	LOW-level input voltage	1.8 V inputs		-	-	0.3 × V <sub>DD(IO)</sub>	V
		3.3 V inputs		-	-	0.3 × V <sub>DD(IO)</sub>	V
I <sub>IL</sub>	LOW-level input current	V <sub>I</sub> = 0 V; no pull-up		-	-	10	μA
I <sub>IH</sub>	HIGH-level input current	V <sub>I</sub> = V <sub>DD(IO)</sub> ; no pull-down	[10]	-	-	10	μA
I <sub>latch</sub>	I/O latch-up current	-(1.5V <sub>DD(IO)</sub> ) < V <sub>I</sub> < (1.5V <sub>DD(IO)</sub> )	[10]	-	-	100	mA

**Table 8. Static characteristics ...continued**  
*T<sub>amb</sub> = -40 °C to +85 °C, unless otherwise specified.*

Symbol	Parameter	Conditions		Min	Typ <sup>[1]</sup>	Max	Unit
C <sub>i</sub>	input capacitance	Excluding bonding pad capacitance		-	-	1.6	pF
V <sub>OL</sub>	LOW-level output voltage	1.8 V outputs; I <sub>OL</sub> = 4 mA	[14]	-	-	0.4	V
		3.3 V outputs; I <sub>OL</sub> = 4 mA	[14]	-	-	0.4	V
I <sub>OL</sub>	LOW-level output current	V <sub>DD(I/O)</sub> = 1.8 V; V <sub>OL</sub> = 0.4 V	[10][14]	3	-	-	mA
		V <sub>DD(I/O)</sub> = 3.3 V; V <sub>OL</sub> = 0.4 V		3	-	-	mA
I <sub>OZ</sub>	OFF-state output current	V <sub>O</sub> = 0 V; V <sub>O</sub> = V <sub>DD(I/O)</sub> ; no pull-up/down	[10]	-	-	10	μA
I <sub>OLS</sub>	LOW-level short-circuit output current	V <sub>DD(I/O)</sub> = 1.8 V; V <sub>OL</sub> = V <sub>DD(I/O)</sub>	[10][15]	-	-	40	mA
		V <sub>DD(I/O)</sub> = 3.3 V; V <sub>OL</sub> = V <sub>DD(I/O)</sub>		-	-	40	mA
<b>ONSW pin</b>							
V <sub>O</sub>	output voltage		[10][11] [12][13]	0	-	V <sub>DD(1V2)</sub>	V
V <sub>OH</sub>	HIGH-level output voltage	1.2 V outputs; I <sub>OH</sub> = -1 mA	[14]	V <sub>DD(1V2)</sub> - 0.4	-	-	V
V <sub>OL</sub>	LOW-level output voltage	1.2 V outputs; I <sub>OL</sub> = 4 mA	[14]	-	-	0.4	V
I <sub>OH</sub>	HIGH-level output current	V <sub>OH</sub> = V <sub>DD(1V2)</sub> - 0.4 V	[10][14]	-4	-	-	mA
I <sub>OL</sub>	LOW-level output current	V <sub>OL</sub> = 0.4 V	[10][14]	3	-	-	mA
I <sub>OZ</sub>	OFF-state output current	V <sub>O</sub> = 0 V; V <sub>O</sub> = V <sub>DD(1V2)</sub> ; no pull-up/down	[10]	-	-	1.5	μA
I <sub>OHS</sub>	HIGH-level short-circuit output current	V <sub>DD(1V2)</sub> = 1.8 V; V <sub>OH</sub> = 0 V	[15]	-	-	-135	mA
I <sub>OLS</sub>	LOW-level short-circuit output current	V <sub>OL</sub> = V <sub>DD(1V2)</sub>	[10][15]	-	-	135	mA
Z <sub>O</sub>	output impedance	V <sub>DD(1V2)</sub> = 1.2 V		40	-	60	Ω
<b>Oscillator input/output pins</b>							
V <sub>i(xtal)</sub>	crystal input voltage	on pins RTCX_IN and SYSX_IN		-0.5	-	+1.3	V
V <sub>o(xtal)</sub>	crystal output voltage	on pins RTCX_OUT and SYSX_OUT		-0.5	-	+1.3	V
<b>RESET pin</b>							
V <sub>I</sub>	input voltage		[10] [12]	0	-	1.95	V
V <sub>IH</sub>	HIGH-level input voltage	1.2 V inputs		0.7 × V <sub>DD(1V2)</sub>	-	-	V
V <sub>IL</sub>	LOW-level input voltage	1.2 V inputs		-	-	0.3 × V <sub>DD(1V2)</sub>	V
I <sub>IL</sub>	LOW-level input current	V <sub>I</sub> = 0 V; no pull-up		-	-	1	μA

**Table 8. Static characteristics ...continued**  
*T<sub>amb</sub> = -40 °C to +85 °C, unless otherwise specified.*

Symbol	Parameter	Conditions	Min	Typ <sup>[1]</sup>	Max	Unit
I <sub>IH</sub>	HIGH-level input current	V <sub>I</sub> = V <sub>DD</sub> ; no pull-down	[10] -	-	1	μA
I <sub>OZ</sub>	OFF-state output current	V <sub>O</sub> = 0 V; V <sub>O</sub> = V <sub>DD</sub> ; no pull-up/down	[10] -	-	1	μA
I <sub>latch</sub>	I/O latch-up current	-(1.5V <sub>DD</sub> ) < V <sub>I</sub> < (1.5V <sub>DD</sub> )	[10] -	-	100	mA

- [1] Typical ratings are not guaranteed. The values listed are at room temperature (25 °C), nominal supply voltages.
- [2] Applies to VDD\_CORE pins.
- [3] Applies to pins VDD\_RTC, VDD\_RTCCORE, and VDD\_RTCOSC.
- [4] Applies to pins VDD\_COREFXD, VDD\_OSC, VDD\_PLL397, VDD\_PLLHCLK, and VDD\_PLLUSB.
- [5] Applies when using 1.8 V Mobile DDR or Mobile SDR SDRAM.
- [6] Applies when using 2.5 V DDR memory.
- [7] Applies when using 3.3 V SDR SDRAM and SRAM.
- [8] Specifies current on combined VDD\_RTCx during normal chip operation: VDD\_RTC, VDD\_CORE, VDD\_OSC = 1.2 V and VDD\_CORE, VDD\_IOx at typical voltage.
- [9] Specifies current on combined VDD\_RTCx during backup operation: VDD\_RTC, VDD\_CORE, VDD\_OSC = 1.2 V and all other VDD\_x at 0 V.
- [10] Referenced to the applicable V<sub>DD</sub> for the pin.
- [11] Including voltage on outputs in 3-state mode.
- [12] The applicable V<sub>DD</sub> voltage for the pin must be present.
- [13] 3-state outputs go into 3-state mode when the applicable V<sub>DD</sub> voltage for the pin is grounded.
- [14] Accounts for 100 mV voltage drop in all supply lines.
- [15] Allowed as long as the current limit does not exceed the maximum current allowed by the device.

### 10.1 Minimum core voltage requirements

Figure 4 shows the minimum core supply voltage that should be applied for a given core frequency on pin VDD\_CORE to ensure stable operation of the LPC3220/30/40/50.

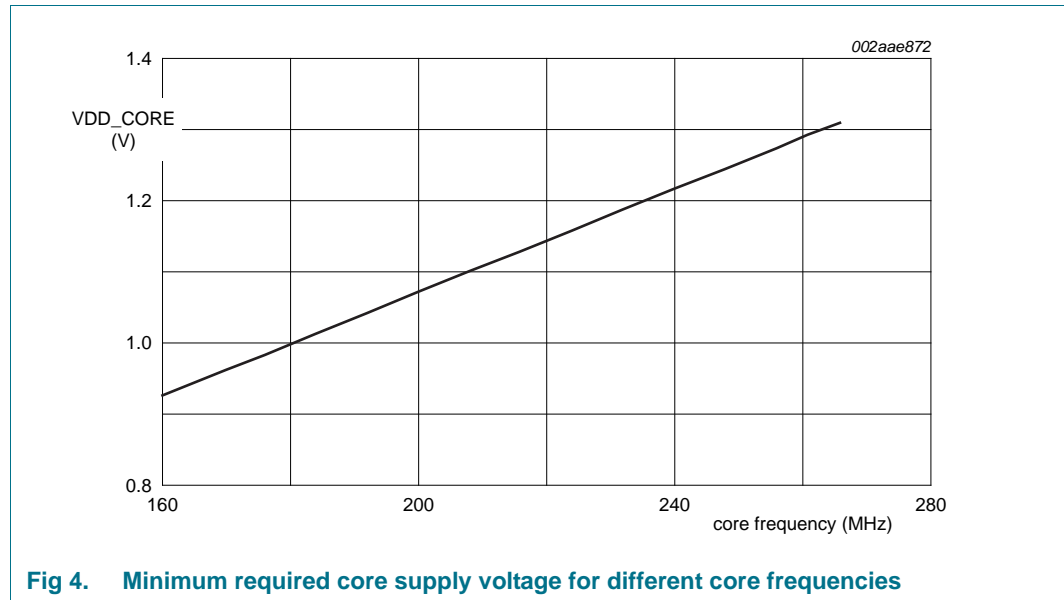

Fig 4. Minimum required core supply voltage for different core frequencies

### 10.2 Power supply sequencing

The LPC32x0 has no power sequencing requirements, that is, VDD(1V2), VDD(EMC), VDD(IO), and VDDA(3V3) can be switched on or off independent of each other. An internal circuit ensures that the system correctly powers up in the absence of core power. During IO power-up this circuit takes care that the system is powered in a defined mode. The same is valid for core power-down.

### 10.3 Power consumption per peripheral

Table 9. Power consumption per peripheral

T<sub>amb</sub> = 25 °C; CPU clock = 208 MHz; I-cache/D-cache, MMU disabled; VDD\_CORE = 1.2 V; VDD(IO) = 1.8 V; USB AHB, IRAM, and IROM clocks always on; all peripherals are at their default state at reset. Peripheral clocks are disabled except for peripheral measured.

Peripheral	I <sub>DD(run)</sub> / mA
High-speed UART (set to 115 200 Bd (8N1))	0.3
I <sup>2</sup> C-bus	0.3
SSP	0.6
I <sup>2</sup> S	0.5
DMA	6.3
EMC	7.3
Multi-level NAND controller	1.4
Single-level NAND controller	0.3
LCD	5.6
Ethernet MAC <sup>[1]</sup>	2.9

[1] All three Ethernet clocks are in enabled in the MAC\_CLK\_CTRL register (see LPC32x0 User manual).

### 10.4 Power consumption in Run mode

Power consumption is shown in [Figure 5](#) for WinCE applications running under typical conditions from SDRAM. MMU and I-cache/D-cache are enabled. The VFP is turned on but not used. I<sup>2</sup>S-interface (channel 1), LCD, SLC NAND controller, I<sup>2</sup>C1-bus, SD card, touchscreen ADC, and UART 3 are turned on. All other peripherals are turned off.

The AHB clock HCLK is identical to the core clock for frequencies up to 133 MHz, which is the maximum allowed HCLK frequency. For higher core frequencies, the HCLK PLL output must be divided by 2 to obtain an HCLK frequency lower than or equal to 133 MHz resulting in correspondingly lower power consumption by the AHB peripherals.

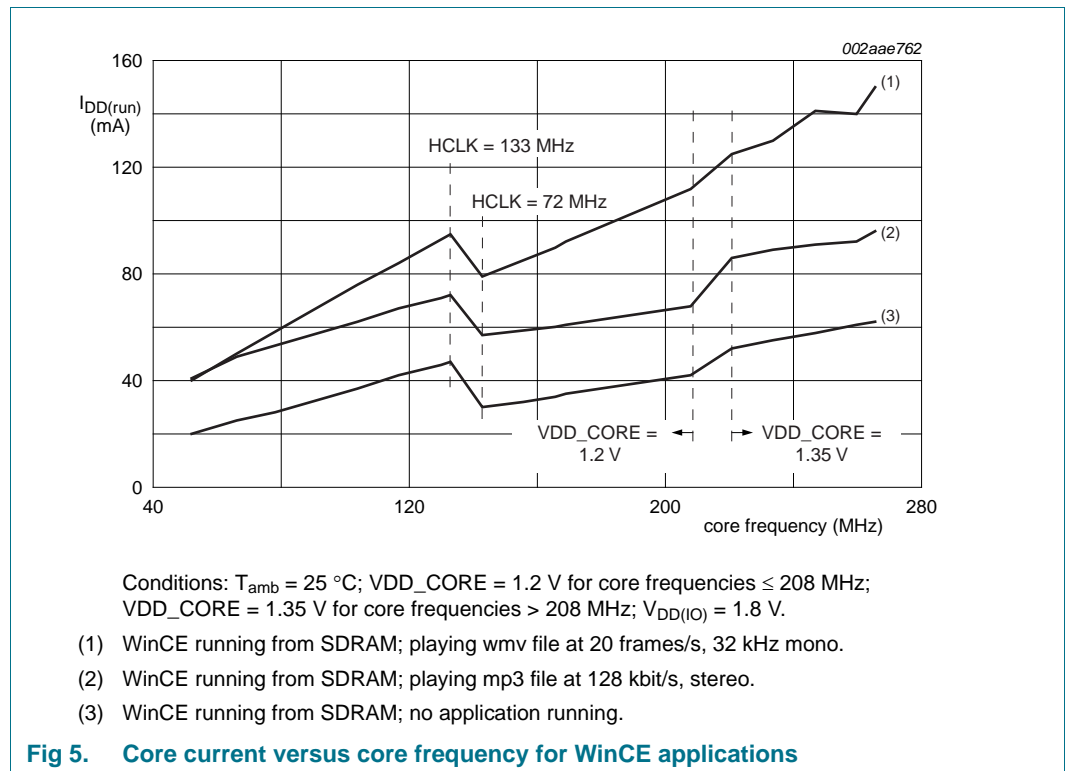

## 10.5 ADC static characteristics

**Table 10. ADC static characteristics**

$V_{DDA(3V3)} = 3.3\text{ V}$ ;  $T_{amb} = 25^\circ\text{C}$  unless otherwise specified; ADC clock frequency 4.5 MHz.

Symbol	Parameter	Conditions	Min	Typ	Max	Unit
$V_{IA}$	analog input voltage		0	-	$V_{DDA(3V3)}$	V
$C_{ia}$	analog input capacitance		-	-	1	pF
$E_D$	differential linearity error		[1][2][3]	$\pm 0.5$	$\pm 1$	LSB
$E_{L(adj)}$	integral non-linearity		[1][4]	$\pm 0.6$	$\pm 1$	LSB
$E_O$	offset error		[1][5]	$\pm 1$	$\pm 3$	LSB
$E_G$	gain error		[1][6]	$\pm 0.3$	$\pm 0.6$	%
$E_T$	absolute error		[1][7]	-	$\pm 4$	LSB
$R_{vsi}$	voltage source interface resistance		-	-	40	k $\Omega$

[1] Conditions:  $V_{SSA} = 0\text{ V}$  (on pin VSS\_AD);  $V_{DDA(3V3)} = 3.3\text{ V}$  (on pin VDD\_AD).

[2] The ADC is monotonic; there are no missing codes.

[3] The differential linearity error ( $E_D$ ) is the difference between the actual step width and the ideal step width. See [Figure 6](#).

[4] The integral non-linearity ( $E_{L(adj)}$ ) is the peak difference between the center of the steps of the actual and the ideal transfer curve after appropriate adjustment of gain and offset errors. See [Figure 6](#).

[5] The offset error ( $E_O$ ) is the absolute difference between the straight line which fits the actual curve and the straight line which fits the ideal curve. See [Figure 6](#).

[6] The gain error ( $E_G$ ) is the relative difference in percent between the straight line fitting the actual transfer curve after removing offset error, and the straight line which fits the ideal transfer curve. See [Figure 6](#).

[7] The absolute error ( $E_T$ ) is the maximum difference between the center of the steps of the actual transfer curve of the non-calibrated ADC and the ideal transfer curve. See [Figure 6](#).

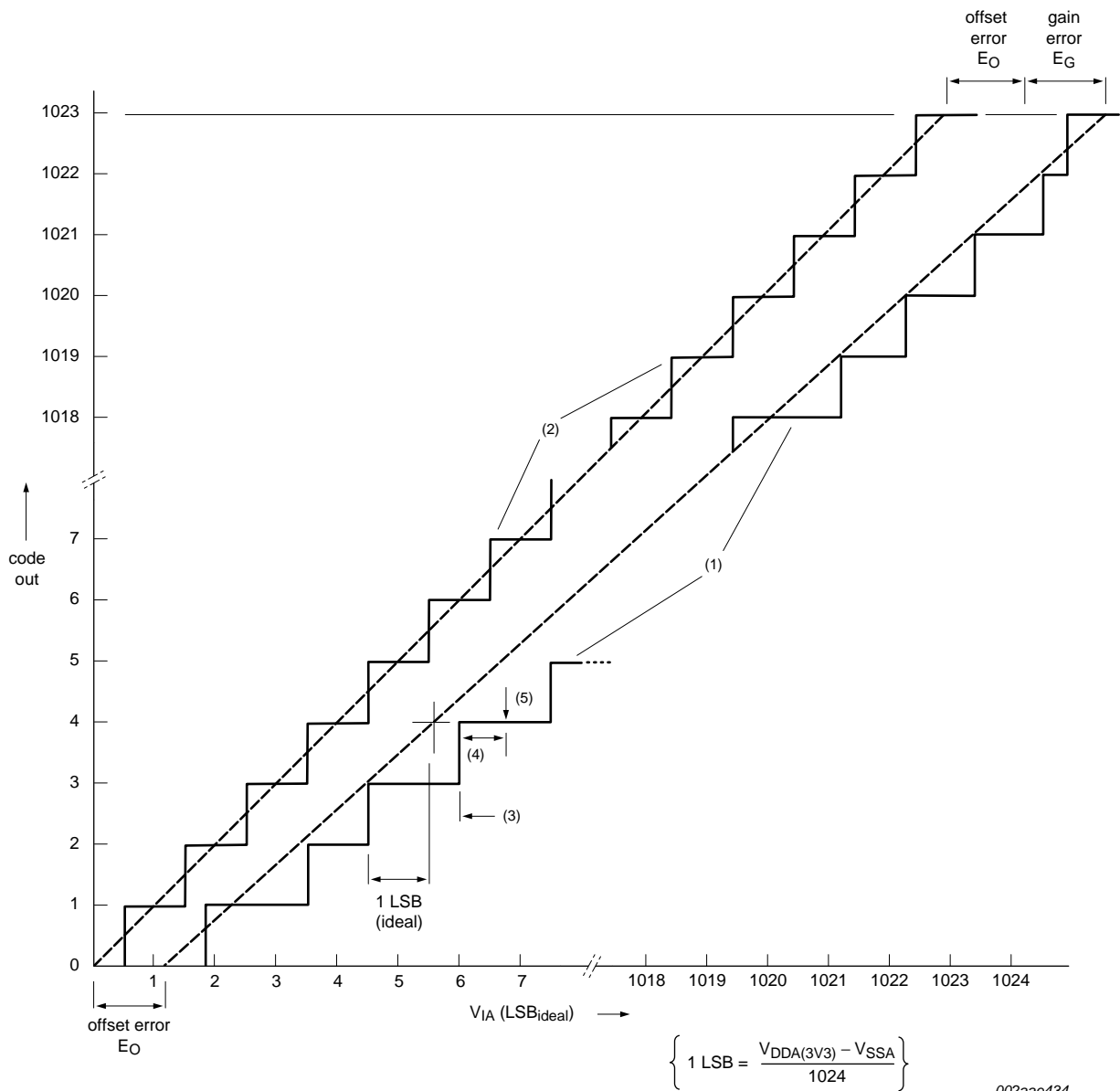

- (1) Example of an actual transfer curve.
- (2) The ideal transfer curve.
- (3) Differential linearity error ( $E_D$ ).
- (4) Integral non-linearity ( $E_{L(adj)}$ ).
- (5) Center of a step of the actual transfer curve.

**Fig 6. ADC characteristics**



## 11. Dynamic characteristics

### 11.1 Clocking and I/O port pins

**Table 11. Dynamic characteristics**

$T_{amb} = -40\text{ °C}$  to  $+85\text{ °C}$ , unless otherwise specified.<sup>[1]</sup>

Symbol	Parameter	Conditions	Min	Typ	Max	Unit
<b>Reset</b>						
$t_{w(\overline{\text{RESET}})_{\text{ext}}}$	external $\overline{\text{RESET}}$ pulse width		[2] 10	-	-	ms
<b>External clock</b>						
$f_{\text{ext}}$	external clock frequency		[3] 1	13	20	MHz
<b>Port pins</b>						
$t_r$	rise time		-	5	-	ns
$t_f$	fall time		-	5	-	ns

- [1] Parameters are valid over operating temperature range unless otherwise specified.  
 [2] After supply voltages are stable  
 [3] Supplied by an external crystal.

### 11.2 Static memory controller

**Table 12. Dynamic characteristics: static external memory interface**

$C_L = 25\text{ pF}$ ,  $T_{amb} = 20\text{ °C}$ ,  $V_{DD(EMC)} = 1.8\text{ V}$ ,  $2.5\text{ V}$ , or  $3.3\text{ V}$ .

Symbol	Parameter	Notes	Min	Typ	Max	Unit
<b>Common to read and write cycles</b>						
$T_{\text{CLCL}}$	clock cycle time	[1]	7.5	9.6	-	ns
$t_{\text{CSLAV}}$	$\overline{\text{CS}}$ LOW to address valid time		-	0	-	ns
<b>Read cycle parameters</b>						
$t_{\text{OELAV}}$	$\overline{\text{OE}}$ LOW to address valid time	[2]	-	$0 - \text{WAITOEN} \times T_{\text{CLCL}}$	-	ns
$t_{\text{BLSLAV}}$	$\overline{\text{BLS}}$ LOW to address valid time	[2]	-	$0 - \text{WAITOEN} \times T_{\text{CLCL}}$	-	ns
$t_{\text{CSLOEL}}$	$\overline{\text{CS}}$ LOW to $\overline{\text{OE}}$ LOW time		-	$0 + \text{WAITOEN} \times T_{\text{CLCL}}$	-	ns
$t_{\text{CSLBLSL}}$	$\overline{\text{CS}}$ LOW to $\overline{\text{BLS}}$ LOW time	[2]	-	$0 + \text{WAITOEN} \times T_{\text{CLCL}}$	-	ns
$t_{\text{OELOEH}}$	$\overline{\text{OE}}$ LOW to $\overline{\text{OE}}$ HIGH time	[2][3]	-	$(\text{WAITRD} - \text{WAITOEN} + 1) \times T_{\text{CLCL}}$	-	ns
$t_{\text{BLSLBLSH}}$	$\overline{\text{BLS}}$ LOW to $\overline{\text{BLS}}$ HIGH time	[2][3]	-	$(\text{WAITRD} - \text{WAITOEN} + 1) \times T_{\text{CLCL}}$	-	ns
$t_{\text{su(DQ)}}$	data input/output set-up time	[6]	-	8.4	-	ns
$t_{\text{h(DQ)}}$	data input/output hold time	[6]	-	0	-	ns
$t_{\text{CSHOEH}}$	$\overline{\text{CS}}$ HIGH to $\overline{\text{OE}}$ HIGH time		-	0	-	ns
$t_{\text{CSHBLSH}}$	$\overline{\text{CS}}$ HIGH to $\overline{\text{BLS}}$ HIGH time		-	0	-	ns
$t_{\text{OEHANV}}$	$\overline{\text{OE}}$ HIGH to address invalid time		-	$1 \times T_{\text{CLCL}}$	-	ns
$t_{\text{BLSHANV}}$	$\overline{\text{BLS}}$ HIGH to address invalid time		-	$1 \times T_{\text{CLCL}}$	-	ns
<b>Write cycle parameters</b>						
$t_{\text{CSLDV}}$	$\overline{\text{CS}}$ LOW to data valid time		-	0	-	ns
$t_{\text{CSLWEL}}$	$\overline{\text{CS}}$ LOW to $\overline{\text{WE}}$ LOW time	[4]	-	$(\text{WAITWEN} + 1) \times T_{\text{CLCL}}$	-	ns
$t_{\text{CSLBLSL}}$	$\overline{\text{CS}}$ LOW to $\overline{\text{BLS}}$ LOW time	[4]	-	$(\text{WAITWEN} + 1) \times T_{\text{CLCL}}$	-	ns
$t_{\text{WELDV}}$	$\overline{\text{WE}}$ LOW to data valid time	[4]	-	$0 - (\text{WAITWEN} + 1) \times T_{\text{CLCL}}$	-	ns

**Table 12. Dynamic characteristics: static external memory interface ...continued**

$C_L = 25\text{ pF}$ ,  $T_{amb} = 20\text{ }^\circ\text{C}$ ,  $V_{DD(EMC)} = 1.8\text{ V}, 2.5\text{ V}, \text{ or } 3.3\text{ V}$ .

Symbol	Parameter	Notes	Min	Typ	Max	Unit
$t_{WELWEH}$	$\overline{WE}$ LOW to $\overline{WE}$ HIGH time	[4][5]	-	$(WAITWR - WAITWEN + 1) \times T_{CLCL}$	-	ns
$t_{BLSLBSLH}$	$\overline{BLS}$ LOW to $\overline{BLS}$ HIGH time	[4][5]	-	$(WAITWR - WAITWEN + 1) \times T_{CLCL}$	-	ns
$t_{WEHANV}$	$\overline{WE}$ HIGH to address invalid time		-	$1 \times T_{CLCL}$	-	ns
$t_{WEHDNV}$	$\overline{WE}$ HIGH to data invalid time		-	$1 \times T_{CLCL}$	-	ns
$t_{BLSHANV}$	$\overline{BLS}$ HIGH to address invalid time		-	$1 \times T_{CLCL}$	-	ns
$t_{BLSHDNV}$	$\overline{BLS}$ HIGH to data invalid time		-	$1 \times T_{CLCL}$	-	ns

[1]  $T_{CLCL} = 1/HCLK$

[2] Refer to the *LPC32x0 User manual* EMCStaticWaitOen0-3 register for the programming of WAITOEN value.

[3] Refer to the *LPC32x0 User manual* EMCStaticWaitRd0-3 register for the programming of WAITRD value.

[4] Refer to the *LPC32x0 User manual* EMCStaticWaitWen0-3 register for the programming of WAITWEN value.

[5] Refer to the *LPC32x0 User manual* EMCStaticWaitWr0-3 register for the programming of WAITWR value.

[6] Earliest of  $\overline{CS}$  HIGH,  $\overline{OE}$  HIGH, address change to data invalid.

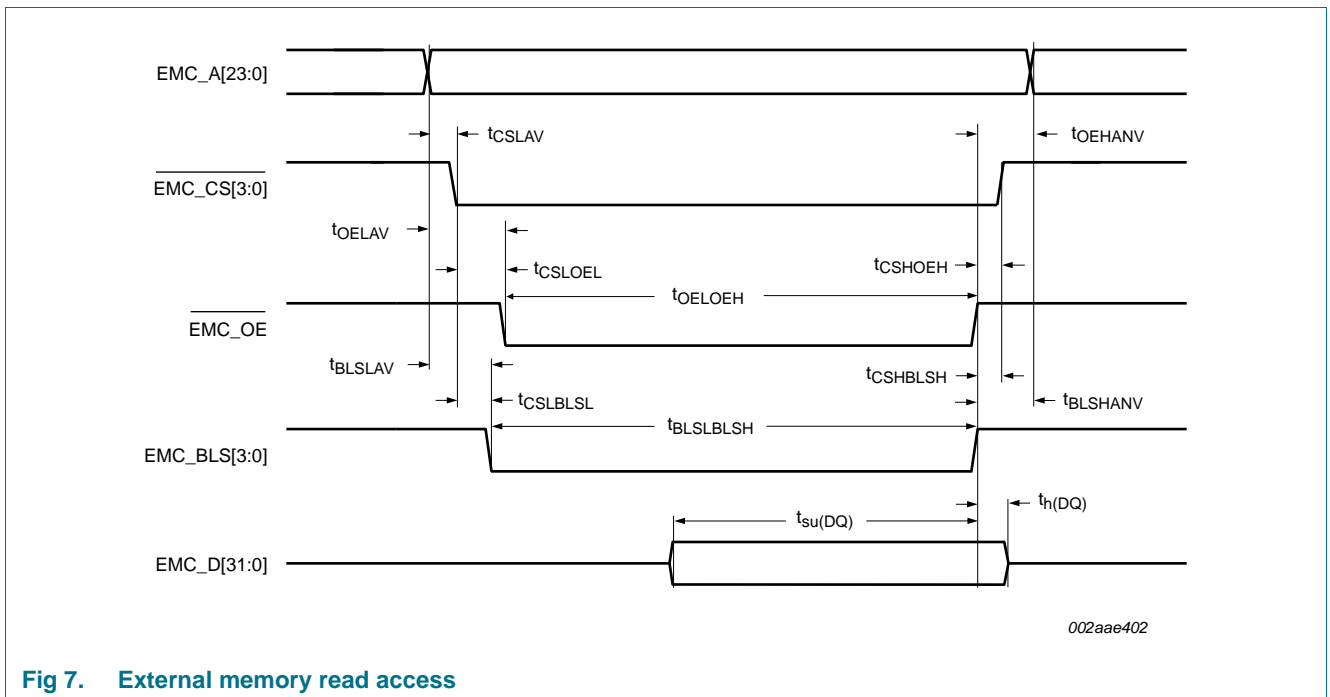

**Fig 7. External memory read access**

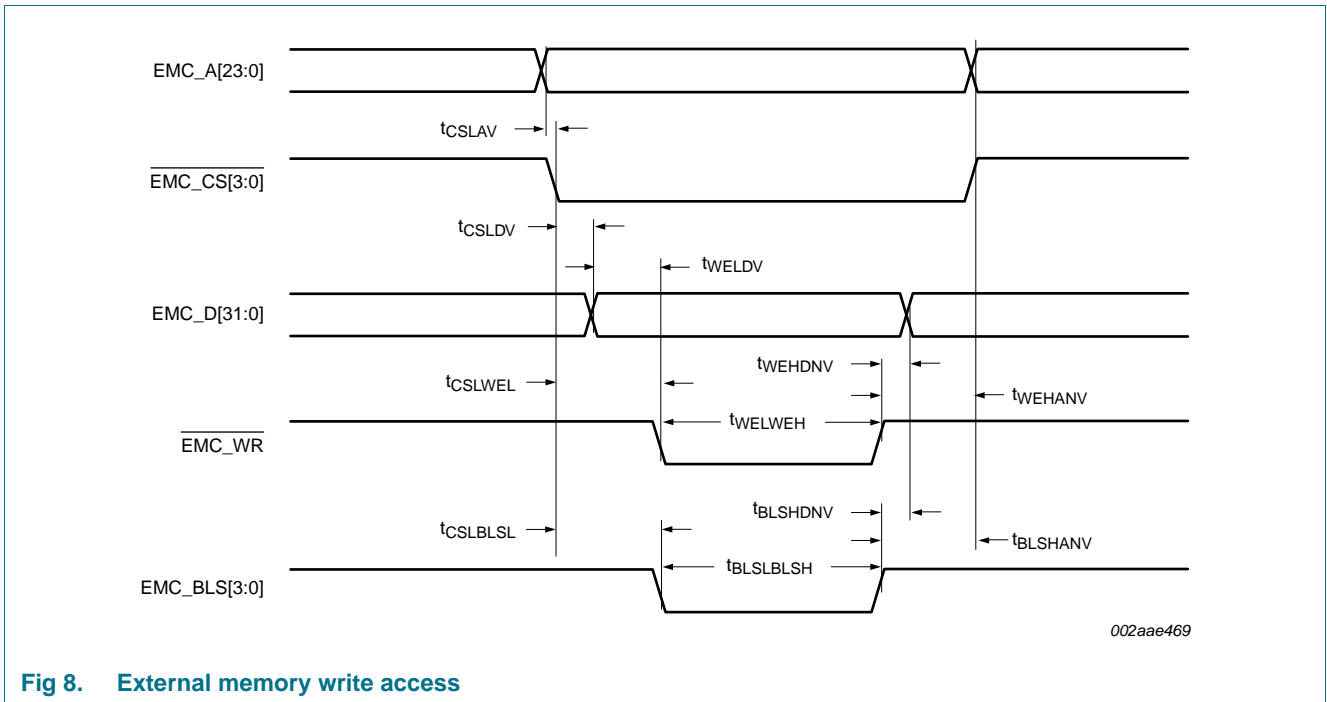

Fig 8. External memory write access

11.3 SDR SDRAM Controller

Table 13. EMC SDR SDRAM memory interface dynamic characteristics

$C_L = 25\text{ pF}$ ,  $T_{amb} = -40\text{ }^\circ\text{C}$  to  $+85\text{ }^\circ\text{C}$ , unless otherwise specified.<sup>[1][3]</sup>

Symbol	Parameter	Min	Typical <sup>[2]</sup>	Max	Unit
$f_{oper}$	operating frequency	[4]	104	133	MHz
$t_{CK}$	clock cycle time	7.5	9.6	-	ns
$t_{CL}$	CK LOW-level width	-	4.8	-	ns
$t_{CH}$	CK HIGH-level width	-	4.8	-	ns
$t_{d(V)ctrl}$	control valid delay time	[5][6]	$(CMD\_DLY \times 0.25) + 2.7$	-	ns
$t_{h(ctrl)}$	control hold time	[5][6]	$(CMD\_DLY \times 0.25) + 1.2$	-	ns
$t_{d(AV)}$	address valid delay time	[6]	$(CMD\_DLY \times 0.25) + 3.2$	-	ns
$t_{h(A)}$	address hold time	[6]	$(CMD\_DLY \times 0.25) + 1.2$	-	ns
$t_{d(QV)}$	data output valid delay time	[6]	$(CMD\_DLY \times 0.25) + 3.5$	-	ns
$t_{h(Q)}$	data output hold time	[6]	$(CMD\_DLY \times 0.25) + 1.2$	-	ns
$t_{su(D)}$	data input set-up time	-	0.6	-	ns
$t_{h(D)}$	data input hold time	-	0.9	-	ns
$t_{QZ}$	data output high-impedance time	-	-	$< t_{CK}$	ns

- [1] Parameters are valid over operating temperature range unless otherwise specified.
- [2] Typical values valid for EMC pads set to fast slew rate:  $VDD\_EMC = 1.8\text{ V}$ ,  $VDD\_CORE = 1.2\text{ V}$  or slower slew rate:  $VDD\_EMC = 3.3\text{ V}$ ,  $VDD\_CORE = 1.2\text{ V}$  (see SDRAMCLK\_CTRL register in the LPC32x0 User manual).
- [3] All min or max values valid for EMC pads set to fast slew rate:  $VDD\_EMC = 1.8\text{ V}$ ,  $VDD\_CORE = 1.2\text{ V}$  or slower slew rate:  $VDD\_EMC = 3.3\text{ V}$ ,  $VDD\_CORE = 1.2\text{ V}$ .
- [4]  $f_{oper} = 1/t_{CK}$ .
- [5] Applies to signals: EMC\_DQM[3:0], EMC\_DYCS[1:0], EMC\_RAS, EMC\_CAS, EMC\_WR, EMC\_CKE[1:0].
- [6]  $CMD\_DLY = COMMAND\_DELAY$  bit field in SDRAMCLK\_CTRL[18:14] register, see External Memory Controller (EMC) chapter in LPC32x0 User manual.

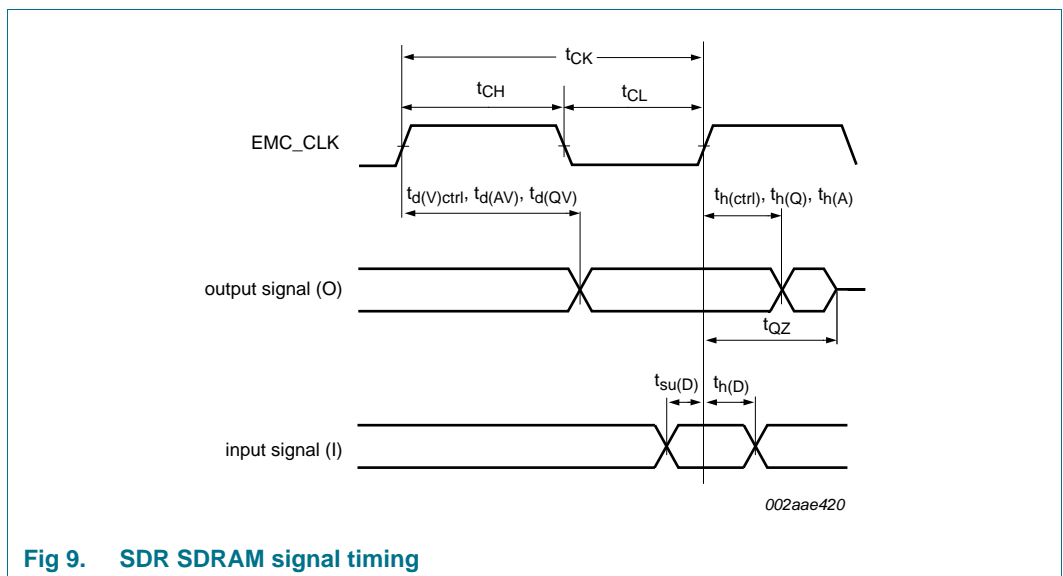

Fig 9. SDR SDRAM signal timing

### 11.4 DDR SDRAM controller

**Table 14. EMC DDR SDRAM memory interface dynamic characteristics<sup>[1]</sup>**

$C_L = 25\text{ pF}$ ,  $T_{amb} = 25\text{ °C}$ , unless otherwise specified.

Symbol	Parameter	Conditions	Min	Typical	Max	Unit
$f_{oper}$	operating frequency		-	104	133	MHz
$t_{CK}$	clock cycle time		7.5	9.6	-	ns
$t_{CL}$	CK LOW-level width		-	$0.5 \times t_{CK}$	-	ns
$t_{CH}$	CK HIGH-level width		-	$0.5 \times t_{CK}$	-	ns
$t_{d(V)ctrl}$	control valid delay time		[2][3]	$(CMD\_DLY \times 0.25) + 1.5$	-	ns
$t_{h(ctrl)}$	control hold time		[2][3]	$(CMD\_DLY \times 0.25) - 1.5$	-	ns
$t_{d(AV)}$	address valid delay time		[2]	$(CMD\_DLY \times 0.25) + 1.5$	-	ns
$t_{h(A)}$	address hold time		[2]	$(CMD\_DLY \times 0.25) - 1.5$	-	ns
$t_{su(Q)}$	data output set-up time	EMC_D[31:0] and EMC_DQM[3:0] to EMC_DQS[1:0] out	[5] 0.08 $\times t_{CK}$	$0.15 \times t_{CK}$	0.25 $\times t_{CK}$	ns
$t_{h(Q)}$	data output hold time	EMC_D[31:0] and EMC_DQM[3:0] to EMC_DQS[1:0] out	[5] 0.25 $\times t_{CK}$	$0.35 \times t_{CK}$	0.42 $\times t_{CK}$	ns
$t_{DQSH}$	DQS HIGH time	for WRITE command	-	$0.5 \times t_{CK}$	-	ns
$t_{DQSL}$	DQS LOW time	for WRITE command	-	$0.5 \times t_{CK}$	-	ns
$t_{DQSS}$	WRITE command to first DQS latching transition time	for DQS out	-	$t_{CK} + 0.7$	-	ns
$t_{DSS}$	DQS falling edge to CK set-up time	for DQS in	-	$0.5 \times t_{CK}$	-	ns
$t_{DSH}$	DQS falling edge hold time from CK	for DQS in	-	$0.5 \times t_{CK}$	-	ns
$t_{d(DQS)}$	DQS delay time	for DQS in	[4]	DQS_DELAY	-	ns
$t_{su(D)}$	data input set-up time		-	0.3	-	ns
$t_{h(D)}$	data input hold time		-	0.5	-	ns

- [1] All values valid for EMC pads set to fast slew rate at 1.8 V unless otherwise specified (see SDRAMCLK\_CTRL register in the *LPC32x0 User manual*).
- [2] CMD\_DLY = COMMAND\_DELAY bit field in SDRAMCLK\_CTRL[18:14] register, see *External Memory Controller (EMC) chapter in LPC32x0 User manual*.
- [3] Applies to signals EMC\_DQM[3:0], EMC\_DYCS[1:0], EMC\_RAS, EMC\_CAS, EMC\_WR, EMC\_CKE[1:0].
- [4] DQS\_DELAY, see *LPC32x0 User manual, External Memory Controller Chapter, Section 8 DDR DQS delay calibration* for details on configuring this value.
- [5] Test conditions for measurements:  $T_{amb} = -40\text{ °C}$  to  $+85\text{ °C}$ ; operating frequency range  $f_{oper} = 52\text{ MHz}$  to  $133\text{ MHz}$ ; EMC\_DQM[3:0] and EMC\_D[31:0] driving 2 inches of  $50\text{ }\Omega$  characteristic impedance trace with  $10\text{ pF}$  capacitive load; no external source series termination resistors used. EMC pads set to fast slew rate at 1.8 V or 2.5 V (see SDRAMCLK\_CTRL register in the *LPC32x0 User manual*).

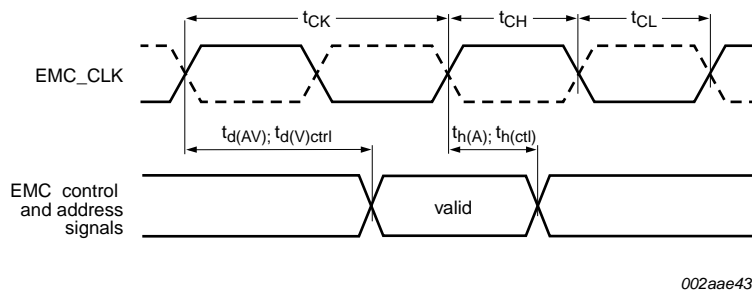

002aae436

Fig 10. DDR control timing parameters

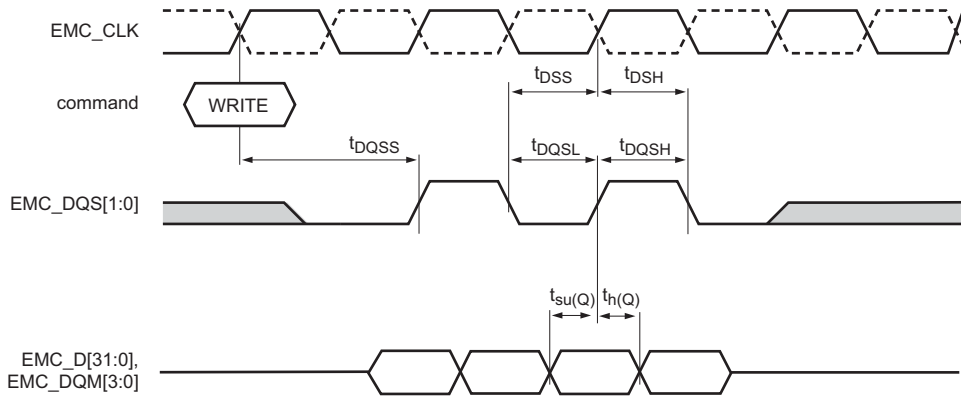

002aae437

Fig 11. DDR write timing parameters

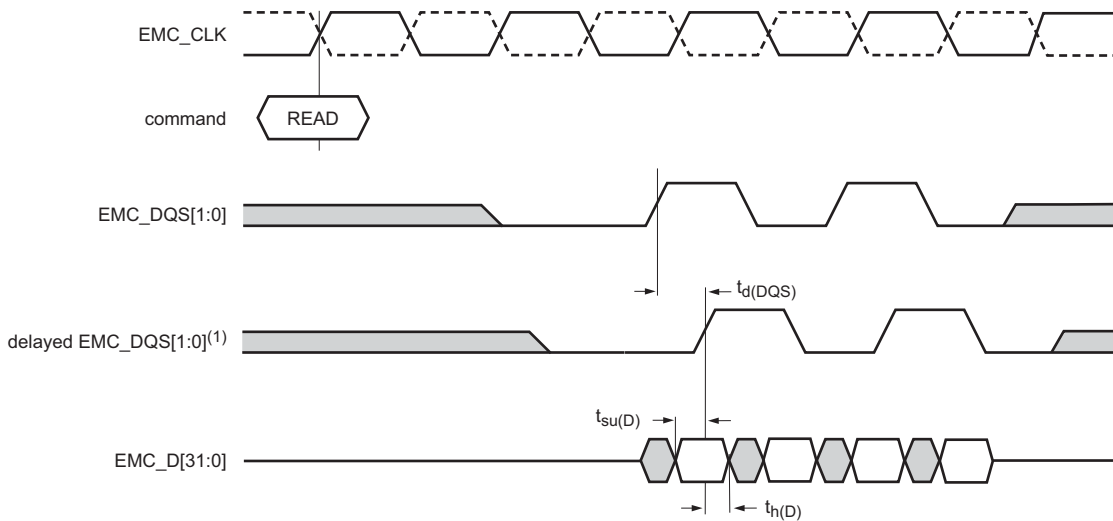

002aae438

(1) The delay of the EMC\_DQS[1:0] signal is determined by the DQS\_DELAY settings. See *LPC32x0 User manual, External Memory Controller Chapter, section DDR DQS delay calibration* for details on configuring this value.

Fig 12. DDR read timing parameters

### 11.5 USB controller

**Table 15. Dynamic characteristics USB digital I/O pins**

$V_{DD(I/O)} = 3.3\text{ V}$ ;  $T_{amb} = -40\text{ }^{\circ}\text{C}$  to  $+85\text{ }^{\circ}\text{C}$ , unless otherwise specified.<sup>[1]</sup>

Symbol	Parameter	Conditions	Min	Typ	Max	Unit
$t_{TIO}$	bus turnaround time (I/O)	OE_N/INT_N to DAT/VP and SE0/VM	-	7	-	ns
$t_{TOI}$	bus turnaround time (O/I)	OE_N/INT_N to DAT/VP and SE0/VM	-	0	-	ns

[1] Parameters are valid over operating temperature range unless otherwise specified.

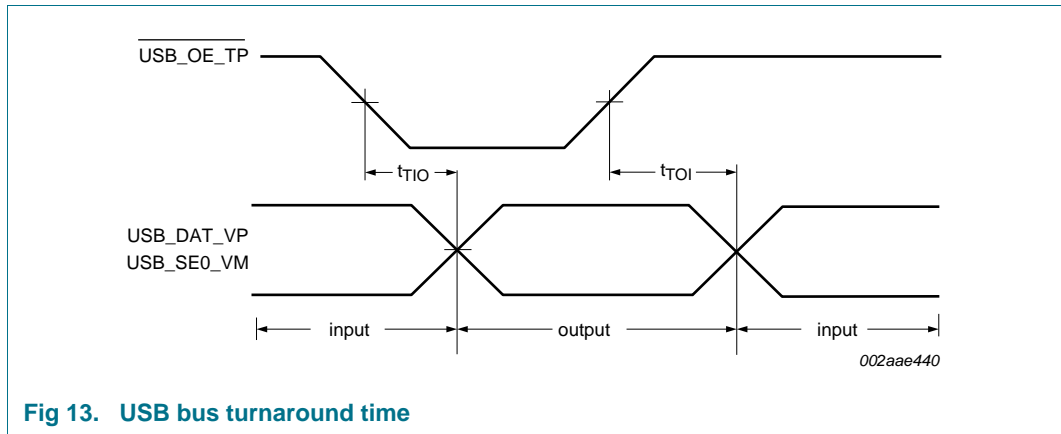

**Fig 13. USB bus turnaround time**

### 11.6 Secure Digital (SD) card interface

**Table 16. Dynamic characteristics: SD card pin interface**

$T_{amb} = -40\text{ }^{\circ}\text{C}$  to  $+85\text{ }^{\circ}\text{C}$  for industrial applications;  $V_{DD(I/O)}$  over specified ranges.<sup>[1]</sup>

Symbol	Parameter	Conditions	Min	Typ <sup>[2]</sup>	Max	Unit
$T_{cy(c\text{lk})}$	clock cycle time	on pin MS_SCLK; Data transfer mode	-	-	25	MHz
		on pin MS_SCLK; Identification mode	-	-	400	kHz
$t_{su(D)}$	data input set-up time	on pins MS_BS, MS_DIO[3:0] as inputs	-	2.7	-	ns
$t_{h(D)}$	data input hold time	on pins MS_BS, MS_DIO[3:0] as inputs	-	0	-	ns
$t_{d(QV)}$	data output valid delay time	on pins MS_BS, MS_DIO[3:0] as outputs	-	9.7	-	ns
$t_{h(Q)}$	data output hold time	on pins MS_BS, MS_DIO[3:0] as outputs	-	7.7	-	ns

[1] Parameters are valid over operating temperature range unless otherwise specified.

[2] Typical ratings are not guaranteed. The values listed are at room temperature (25 °C), nominal supply voltages.

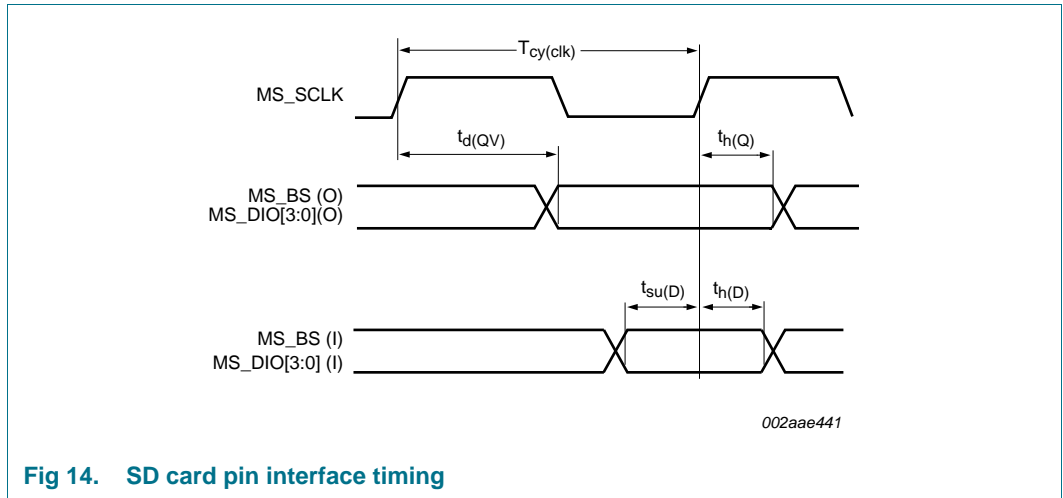

Fig 14. SD card pin interface timing

### 11.7 MLC NAND flash memory controller

Table 17. Dynamic characteristics of the MLC NAND flash memory controller

$T_{amb} = -40\text{ °C to }+85\text{ °C}$ .

Symbol	Parameter		Min	Typ	Max	Unit
$t_{CELREL}$	$\overline{CE}$ LOW to $\overline{RE}$ LOW time	[1][2]	-	$T_{HCLK} \times CEA_D$	-	ns
$t_{RC}$	$\overline{RE}$ cycle time	[1][5][6]	-	$T_{HCLK} \times (R_L + 1) + T_{HCLK} \times (R_H - R_L)$	-	ns
$t_{REH}$	$\overline{RE}$ HIGH hold time	[1][5][6]	-	$T_{HCLK} \times (R_H - R_L)$	-	ns
$t_{RHZ}$	$\overline{RE}$ HIGH to output high-impedance time	[1][5][7]	-	$T_{HCLK} \times (R_H - R_L) + T_{HCLK} \times R_{HZ}$	-	ns
$t_{RP}$	$\overline{RE}$ pulse width	[1][5]	-	$T_{HCLK} \times (R_L + 1)$	-	ns
$t_{REHRBL}$	$\overline{RE}$ HIGH to $R/\overline{B}$ LOW time	[1][8]	-	$T_{HCLK} \times B_D$	-	ns
$t_{WB}$	$\overline{WE}$ HIGH to $R/\overline{B}$ LOW time	[1][8]	-	$T_{HCLK} \times B_D$	-	ns
$t_{WC}$	$\overline{WE}$ cycle time	[1][3][4]	-	$T_{HCLK} \times (W_L + 1) + T_{HCLK} \times (W_H - W_L)$	-	ns
$t_{WH}$	$\overline{WE}$ HIGH hold time	[1][3][4]	-	$T_{HCLK} \times (W_H - W_L)$	-	ns
$t_{WP}$	$\overline{WE}$ pulse width	[1][3]	-	$T_{HCLK} \times (W_L + 1)$	-	ns

- [1]  $T_{HCLK} = 1/HCLK$
- [2]  $CEA_D$  = bit field TCEA\_DELAY[1:0] in register MLC\_TIME\_REG[25:24]
- [3]  $W_L$  = bit field WR\_LOW[3:0] in register MLC\_TIME\_REG[3:0]
- [4]  $W_H$  = bit field WR\_HIGH[3:0] in register MLC\_TIME\_REG[7:4]
- [5]  $R_L$  = bit field RD\_LOW[3:0] in register MLC\_TIME\_REG[11:8]
- [6]  $R_H$  = bit field RD\_HIGH [3:0] in register MLC\_TIME\_REG[15:12]
- [7]  $R_{HZ}$  = bit field NAND\_TA[2:0] in register MLC\_TIME\_REG[18:16]
- [8]  $B_D$  = bit field BUSY\_DELAY[4:0] in register MLC\_TIME\_REG[23:19]



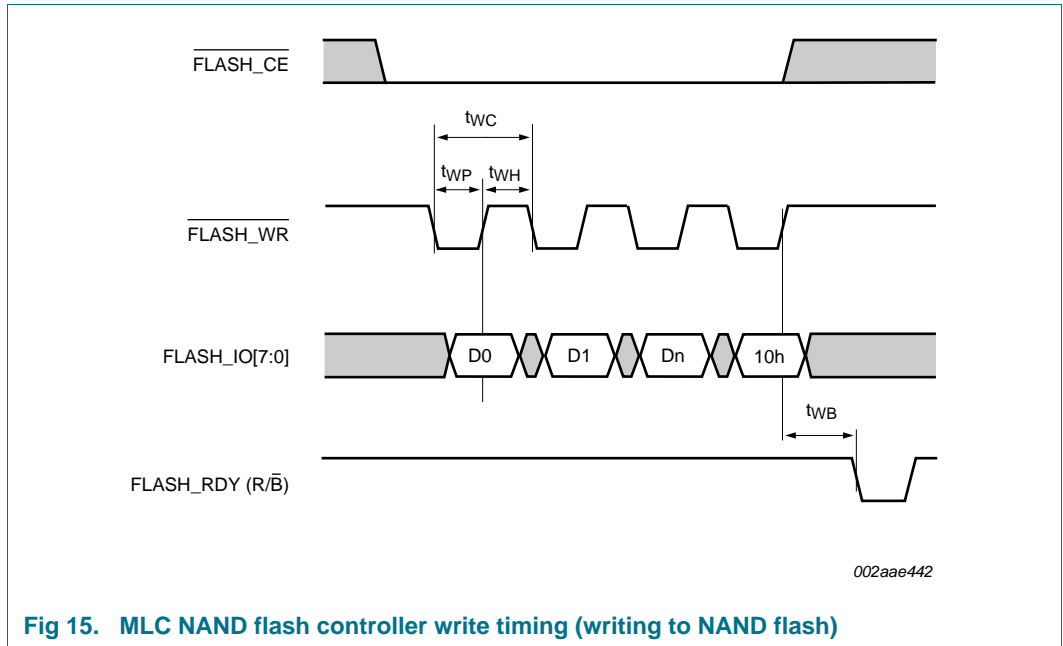

Fig 15. MLC NAND flash controller write timing (writing to NAND flash)

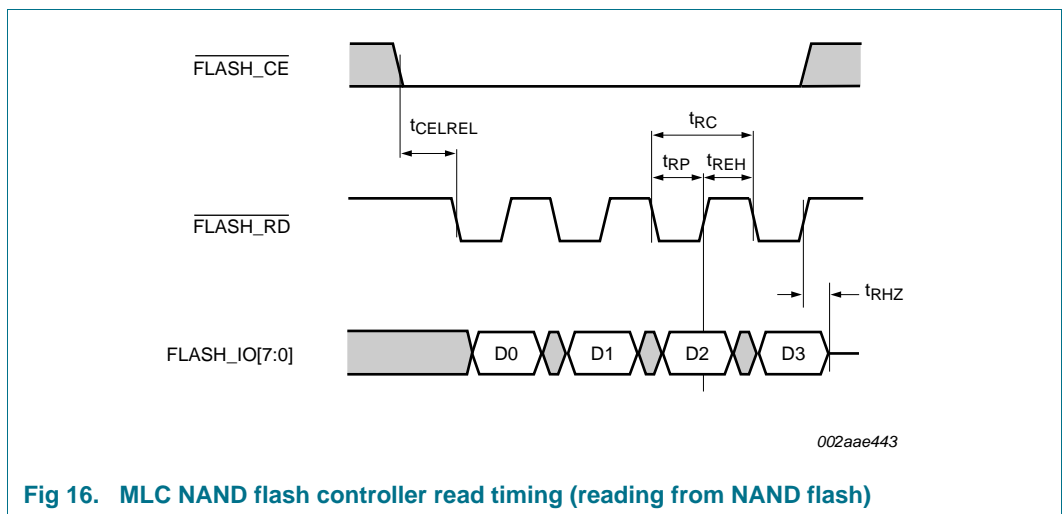

Fig 16. MLC NAND flash controller read timing (reading from NAND flash)

### 11.8 SLC NAND flash memory controller

Table 18. Dynamic characteristics of SLC NAND flash memory controller

$T_{amb} = -40\text{ }^{\circ}\text{C to }+85\text{ }^{\circ}\text{C}$ .

Symbol	Parameter	Conditions		Min	Typ	Max	Unit
$t_{ALS}$	ALE set-up time	read	[1][2][4][6]	-	$T_{HCLK} \times (R_{su} + R_w)$	-	ns
		write		-	$T_{HCLK} \times (W_{su} + W_w)$	-	ns
$t_{ALH}$	ALE hold time	read	[1][7]	-	$T_{HCLK} \times R_h$	-	ns
		write		-	$T_{HCLK} \times W_h$	-	ns
$t_{AR}$	ALE to RE delay time	read	[1][2][6]	-	$T_{HCLK} \times R_{su}$	-	ns
		write		-	$T_{HCLK} \times W_{su}$	-	ns

Table 18. Dynamic characteristics of SLC NAND flash memory controller ...continued

 $T_{amb} = -40\text{ }^{\circ}\text{C}$  to  $+85\text{ }^{\circ}\text{C}$ .

Symbol	Parameter	Conditions		Min	Typ	Max	Unit
t <sub>CEA</sub>	$\overline{\text{CE}}$ access time	read	[1][2][4][6][8]	-	$T_{\text{HCLK}} \times (\text{Rsu} + \text{Rw})$	-	ns
		write		-	$T_{\text{HCLK}} \times (\text{Wsu} + \text{Ww})$	-	ns
t <sub>CS</sub>	$\overline{\text{CE}}$ set-up time	read	[1][2][4][6][8]	-	$T_{\text{HCLK}} \times (\text{Rsu} + \text{Rw})$	-	ns
		write		-	$T_{\text{HCLK}} \times (\text{Wsu} + \text{Ww})$	-	ns
t <sub>CH</sub>	$\overline{\text{CE}}$ hold time	read	[1][3]	-	$T_{\text{HCLK}} \times \text{Rh}$	-	ns
		write		-	$T_{\text{HCLK}} \times \text{Wh}$	-	ns
t <sub>CLS</sub>	CLE set-up time	read	[1][2][4][6][8]	-	$T_{\text{HCLK}} \times (\text{Rsu} + \text{Rw})$	-	ns
		write		-	$T_{\text{HCLK}} \times (\text{Wsu} + \text{Ww})$	-	ns
t <sub>CLH</sub>	CLE hold time	read	[1][3]	-	$T_{\text{HCLK}} \times \text{Rh}$	-	ns
		write		-	$T_{\text{HCLK}} \times \text{Wh}$	-	ns
t <sub>CLR</sub>	CLE to $\overline{\text{RE}}$ delay time	read	[1][2][6]	-	$T_{\text{HCLK}} \times \text{Rsu}$	-	ns
		write		-	$T_{\text{HCLK}} \times \text{Wsu}$	-	ns
t <sub>DH</sub>	data hold time	output from NAND controller; read	[1][3][7]	-	$T_{\text{HCLK}} \times \text{Rh}$	-	ns
		output from NAND controller; write		-	$T_{\text{HCLK}} \times \text{Wh}$	-	ns
t <sub>DS</sub>	data set-up time	output from NAND controller; read	[1][2][4][6][8]	-	$T_{\text{HCLK}} \times (\text{Rsu} + \text{Rw})$	-	ns
		output from NAND controller; write		-	$T_{\text{HCLK}} \times (\text{Wsu} + \text{Ww})$	-	ns
t <sub>IR</sub>	output high-impedance to $\overline{\text{RE}}$ LOW time	read	[1][2][6]	-	$T_{\text{HCLK}} \times \text{Rsu}$	-	ns
		write		-	$T_{\text{HCLK}} \times \text{Wsu}$	-	ns
t <sub>RC</sub>	$\overline{\text{RE}}$ cycle time	read	[1][2]	-	$T_{\text{HCLK}} \times (\text{Rsu} + \text{Rw} + \text{Rh})$	-	ns
t <sub>REA</sub>	$\overline{\text{RE}}$ access time	read	[1][4]	-	$T_{\text{HCLK}} \times \text{Rw}$	-	ns
t <sub>REH</sub>	$\overline{\text{RE}}$ high hold time	read	[1][2][3]	-	$T_{\text{HCLK}} \times (\text{Rsu} + \text{Rh})$	-	ns
t <sub>RHOH</sub>	$\overline{\text{RE}}$ HIGH to output hold time	input hold for flash controller; read		-	0	-	-
		input hold for flash controller; write		-	0	-	-
t <sub>RHZ</sub>	$\overline{\text{RE}}$ HIGH to output high-impedance time	read	[1]	-	$T_{\text{HCLK}} \times \text{Rh}$	-	ns
t <sub>RP</sub>	$\overline{\text{RE}}$ pulse width	read	[1][4]	-	$T_{\text{HCLK}} \times \text{Rw}$	-	ns
t <sub>RR</sub>	ready to $\overline{\text{RE}}$ LOW time	read	[1][2][3]	-	$T_{\text{HCLK}} \times \text{Rsu}$	-	ns
t <sub>WB</sub>	$\overline{\text{WE}}$ HIGH to $\text{R}/\overline{\text{B}}$ LOW time	write	[1][7][9]	-	$(T_{\text{HCLK}} \times \text{Wh}) + (2 \times T_{\text{HCLK}} \times \text{Wb})$	-	ns
t <sub>WC</sub>	$\overline{\text{WE}}$ cycle time	write	[1][6][7][8]	-	$T_{\text{HCLK}} \times (\text{Wsu} + \text{Ww} + \text{Wh})$	-	ns

Table 18. Dynamic characteristics of SLC NAND flash memory controller ...continued

$T_{amb} = -40\text{ }^{\circ}\text{C}$  to  $+85\text{ }^{\circ}\text{C}$ .

Symbol	Parameter	Conditions	Min	Typ	Max	Unit
$t_{WH}$	$\overline{WE}$ HIGH hold time	write	[1][6][7]	$T_{HCLK} \times (Wsu + Wh)$	-	ns
$t_{WHR}$	$\overline{WE}$ HIGH to $\overline{RE}$ LOW time	write	[1][7][9]	$(T_{HCLK} \times Wh) + (2 \times T_{HCLK} \times Wb)$	-	ns
$t_{WP}$	$\overline{WE}$ pulse width	write	[1][8]	$T_{HCLK} \times Ww$	-	ns
$t_{REHRBL}$	$\overline{RE}$ HIGH to R/B LOW time	write	[1][3][5]	$(T_{HCLK} \times Rh) + (2 \times T_{HCLK} \times Rb)$	-	ns

- [1]  $T_{HCLK} = 1/HCLK$
- [2]  $Rsu$  = bit field R\_SETUP[3:0] in register SLC\_TAC[3:0] for reads
- [3]  $Rh$  = bit field R\_HOLD[3:0] in register SLC\_TAC[7:4] for reads
- [4]  $Rw$  = bit field R\_WIDTH[3:0] in register SLC\_TAC[11:8] for reads
- [5]  $Rb$  = bit field R\_RDY[3:0] in register SLC\_TAC[15:12] for reads
- [6]  $Wsu$  = bit field W\_SETUP[3:0] in register SLC\_TAC[19:16] for writes
- [7]  $Wh$  = bit field W\_HOLD[3:0] in register SLC\_TAC[23:20] for writes
- [8]  $Ww$  = bit field W\_WIDTH[3:0] in register SLC\_TAC[27:24] for writes
- [9]  $Wb$  = bit field W\_RDY[3:0] in register SLC\_TAC[31:28] for writes

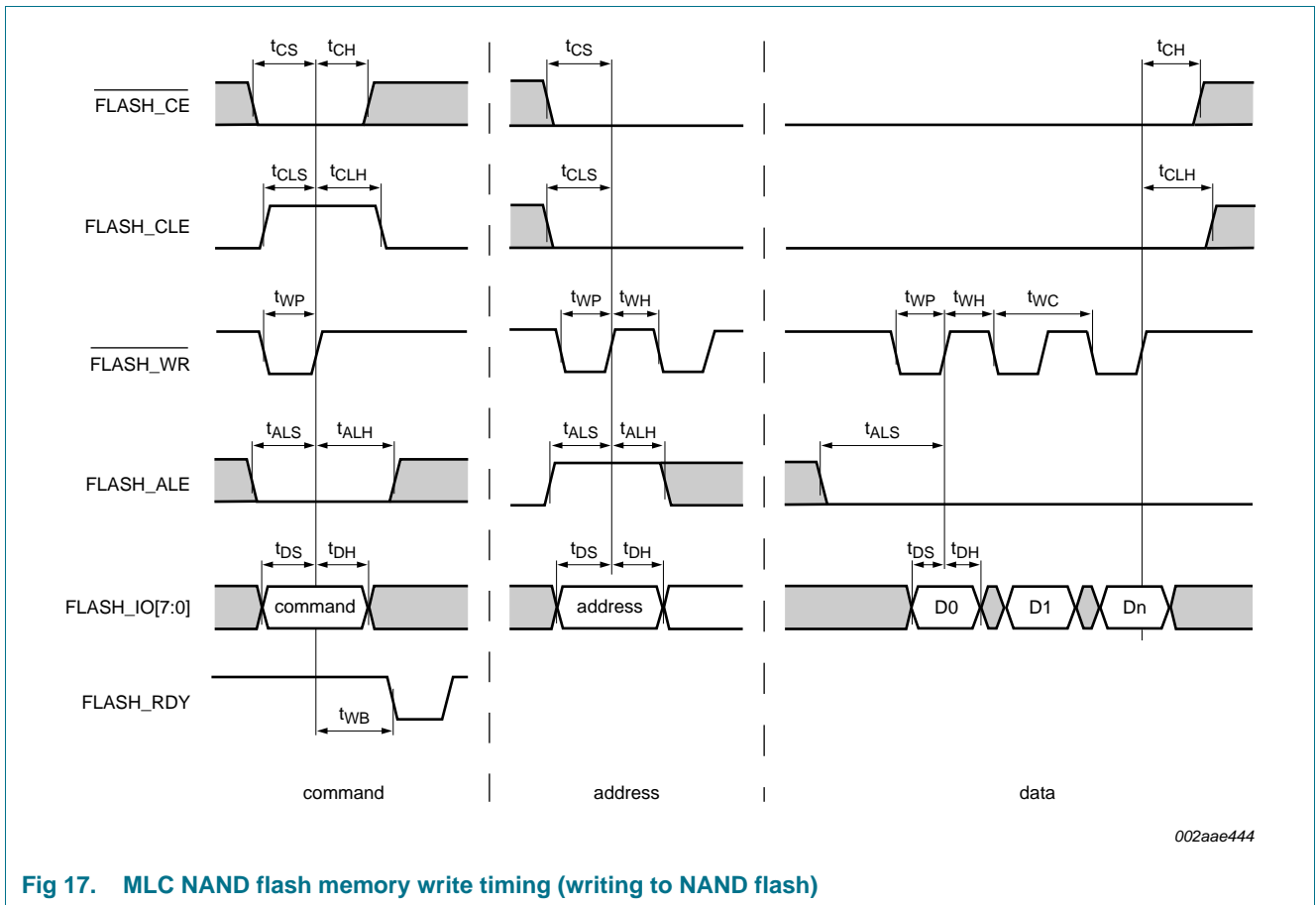

Fig 17. MLC NAND flash memory write timing (writing to NAND flash)

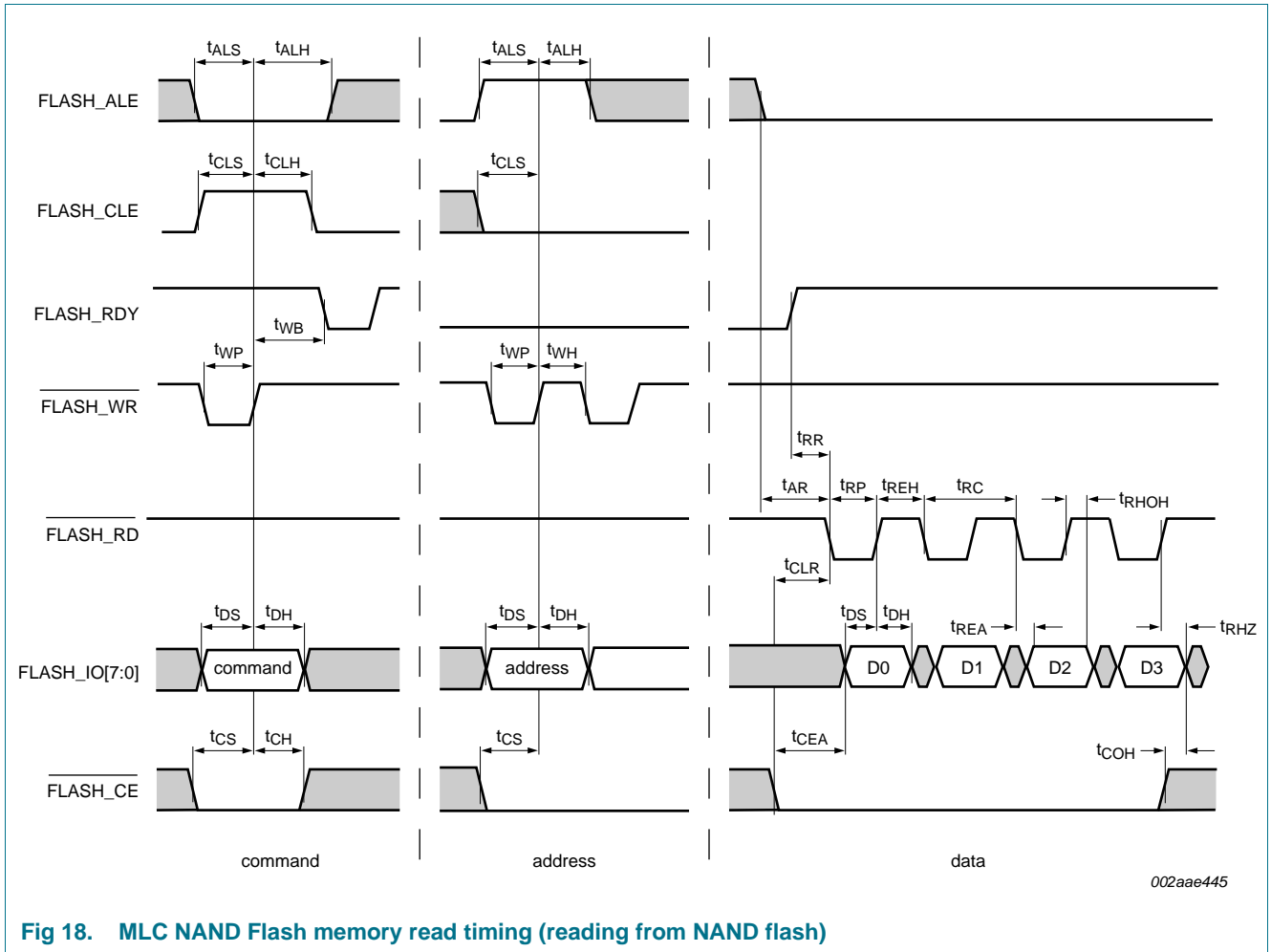

Fig 18. MLC NAND Flash memory read timing (reading from NAND flash)

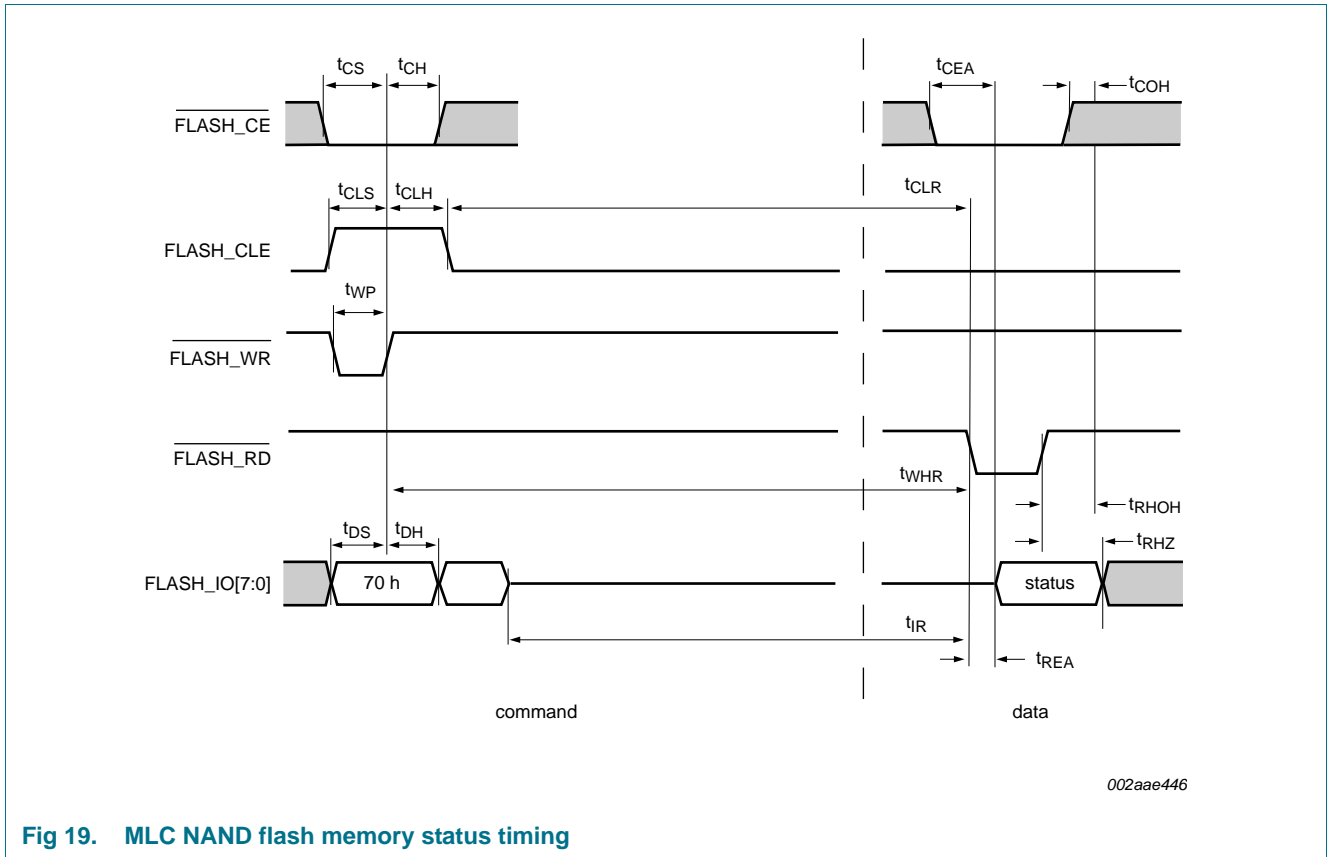

Fig 19. MLC NAND flash memory status timing

## 11.9 SPI and SSP Controller

### 11.9.1 SPI

Table 19. Dynamic characteristics of SPI pins on SPI master controller

$T_{amb} = -40\text{ }^{\circ}\text{C to }+85\text{ }^{\circ}\text{C}$ .

Symbol	Parameter	Min	Typ	Max	Unit
<b>Common to SPI1 and SPI2</b>					
$T_{SPICYC}$	SPI cycle time	[1]	$2 \times T_{HCLK}$	$256 \times T_{HCLK}$	ns
<b>SPI1</b>					
$t_{SPIDSU}$	SPI data set-up time	-	6	-	ns
$t_{SPIDH}$	SPI data hold time	-	0	-	ns
$t_{SPIDV}$	SPI enable to output data valid time	-	2	-	ns
$t_{SPIOH}$	SPI output data hold time	-	0	-	ns
<b>SPI2</b>					
$t_{SPIDSU}$	SPI data set-up time	-	10	-	ns
$t_{SPIDH}$	SPI data hold time	-	0	-	ns
$t_{SPIDV}$	SPI enable to output data valid time	-	2	-	ns
$t_{SPIOH}$	SPI output data hold time	-	0	-	ns

[1]  $T_{HCLK}$  = period time of SPI IP block input clock (HCLK)

11.9.2 Timing diagrams for SPI and SSP (in SPI mode)

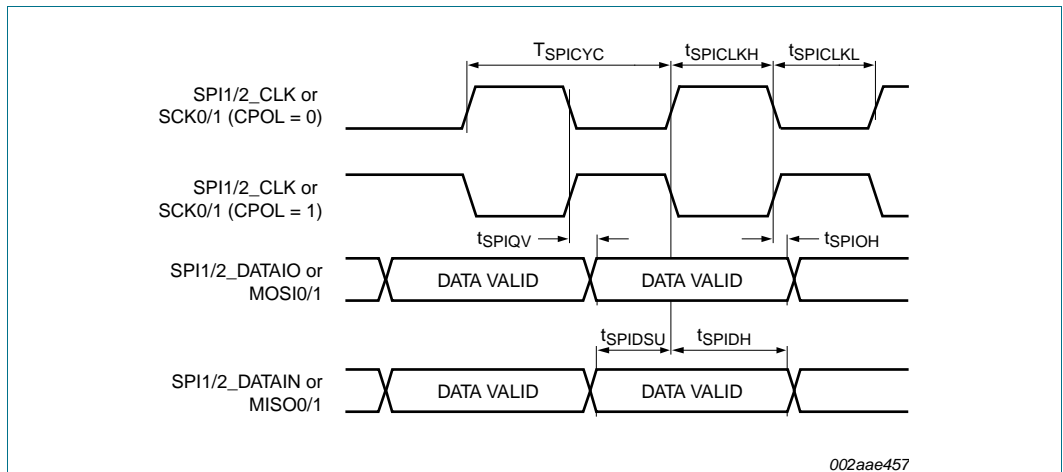

Fig 20. SPI master timing (CPHA = 0)

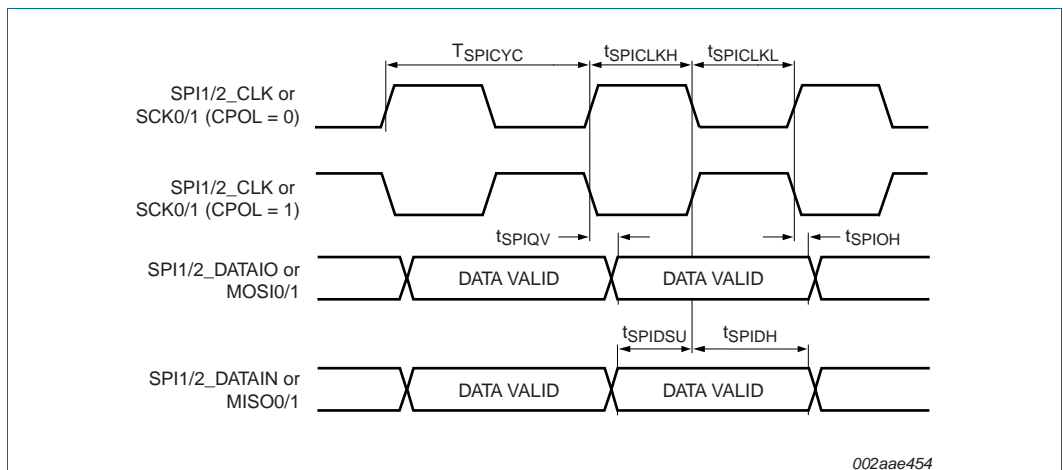

Fig 21. SPI master timing (CPHA = 1)

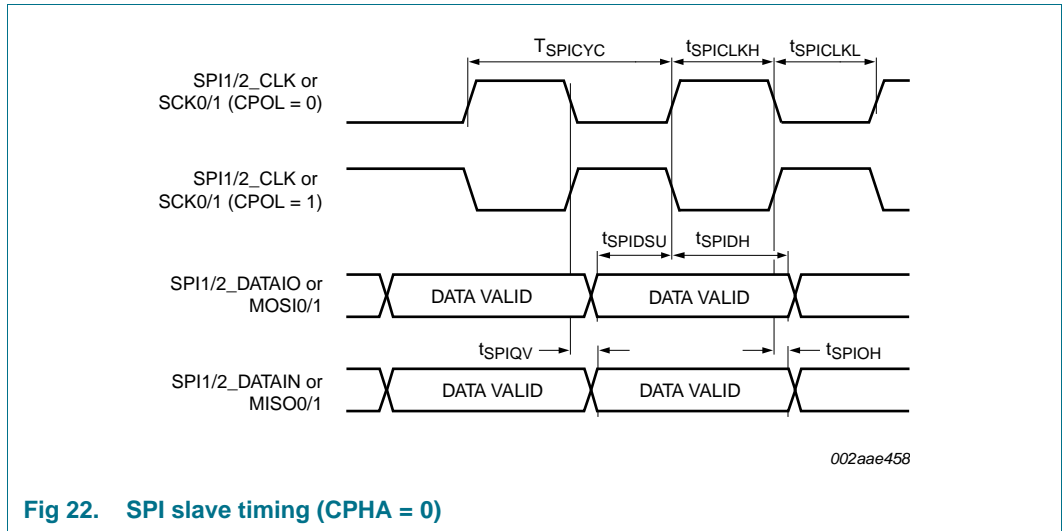

Fig 22. SPI slave timing (CPHA = 0)

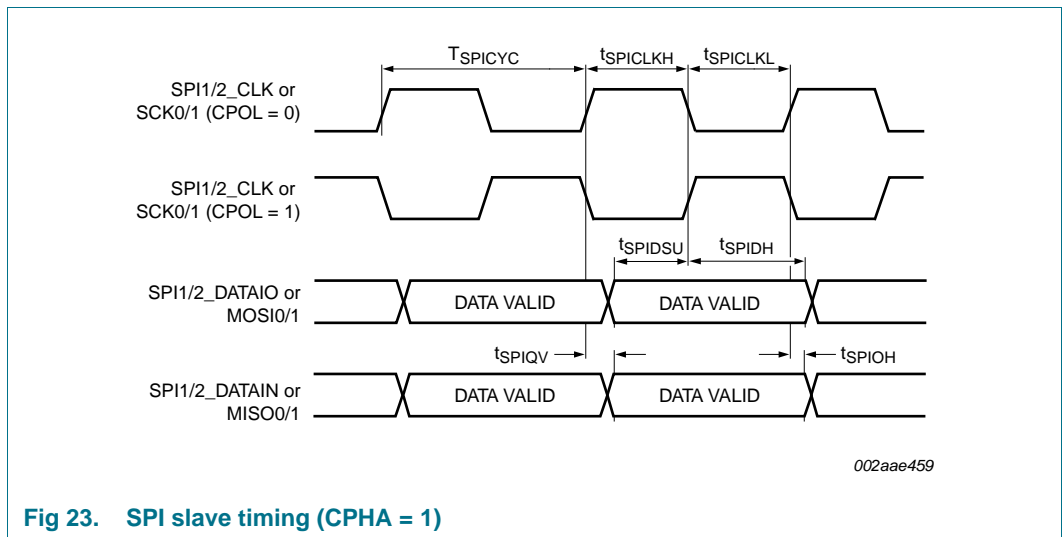

Fig 23. SPI slave timing (CPHA = 1)

## 12. Application information

### 12.1 Connecting the JTAG\_NTRST pin

To ensure that pin JTAG\_NTRST is LOW at POR, use one the following board design options:

- Tie JTAG\_NTRST LOW. In this case, you will not be able to use the JTAG port in a production design. Tying JTAG\_NTRST LOW does not affect normal operation (code execution) of the part but does prevent JTAG access.
- Implement recommended circuit shown in [Figure 24](#).

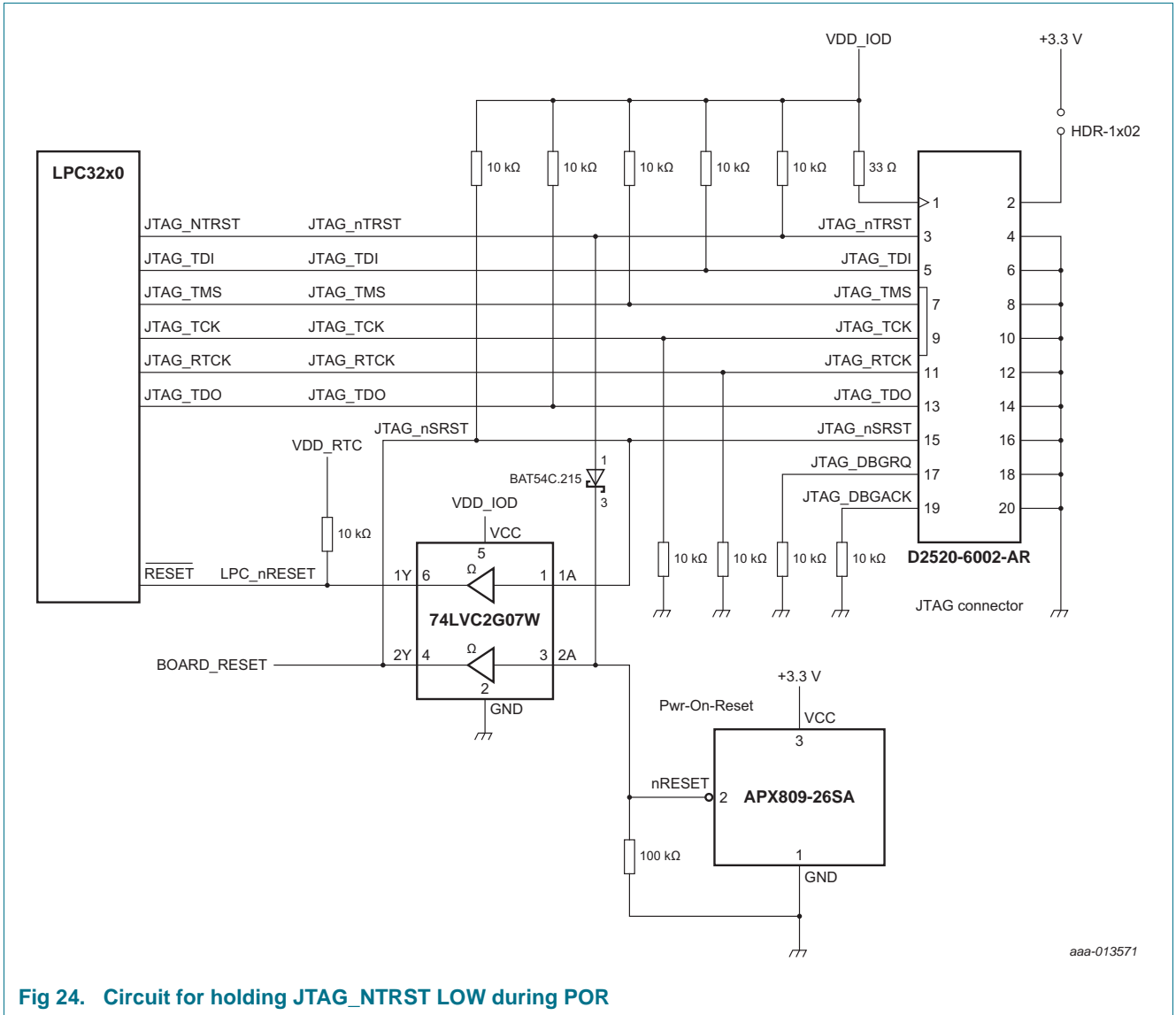



13. Package outline

TFBGA296: plastic thin fine-pitch ball grid array package; 296 balls

SOT1048-1

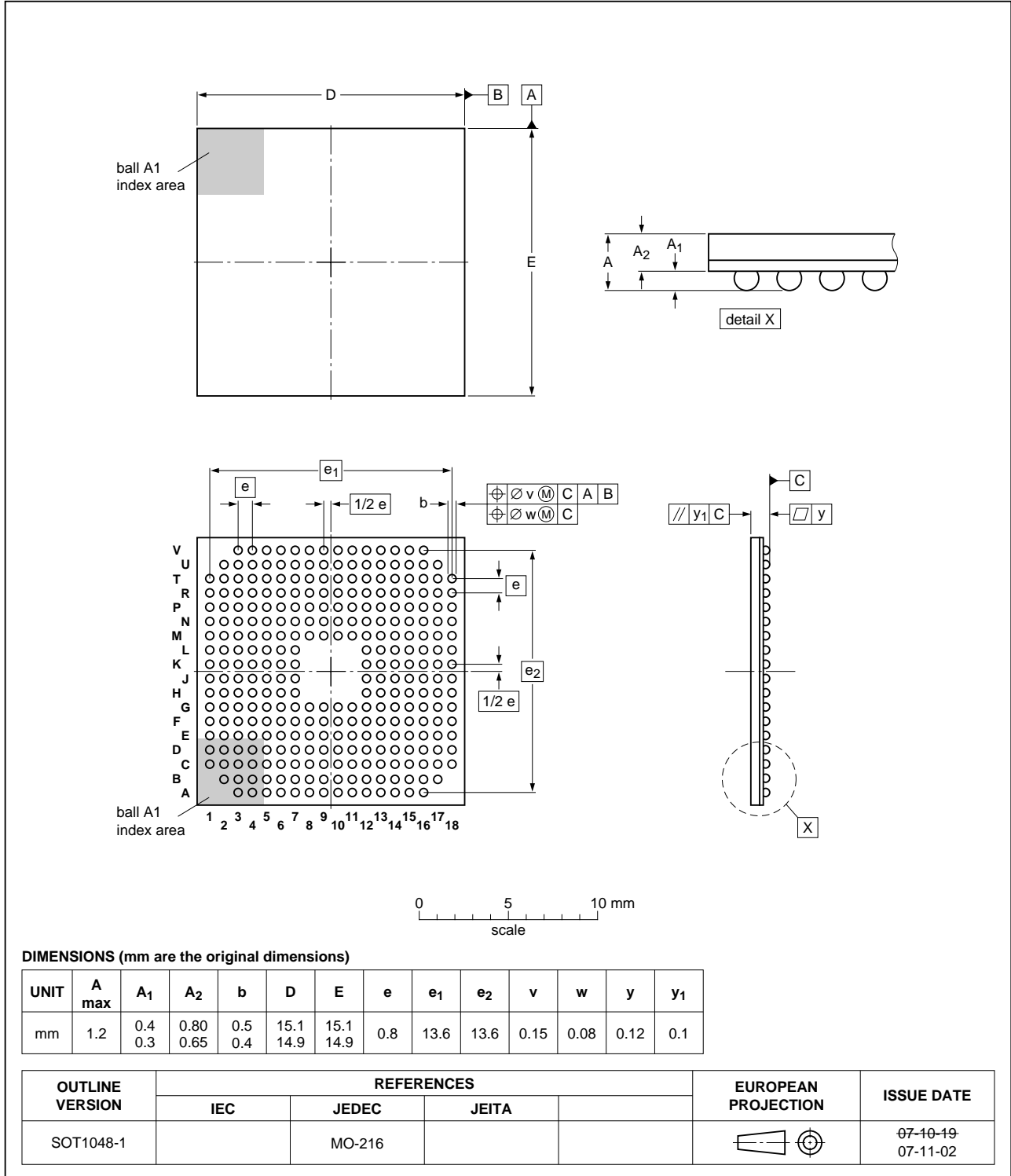

Fig 25. Package outline SOT1048-1 (TFBGA296)

## 14. Abbreviations

Table 20. Abbreviations

Acronym	Description
ADC	Analog-to-Digital Converter
AHB	Advanced High-performance Bus
AMBA	Advanced Microcontroller Bus Architecture
APB	Advanced Peripheral Bus
BSDL	Boundary Scan Description Language
CISC	Complex Instruction Set Computer
DDR SDRAM	Double Data Rate Synchronous Dynamic Random Access Memory
DMA	Direct Memory Access
DSP	Digital Signal Processing
ETM	Embedded Trace Macrocell
FAB	Fast Access Bus
FIFO	First In, First Out
FIQ	Fast Interrupt Request
GPIO	General Purpose Input/Output
I/O	Input/Output
IRQ	Interrupt Request
HS	High-Speed
IrDA	Infrared Data Association
JTAG	Joint Test Action Group
LCD	Liquid Crystal Display
MAC	Media Access Control
MIIM	Media Independent Interface Management
OHCI	Open Host Controller Interface
OTG	On-The-Go
PHY	Physical Layer
PLL	Phase-Locked Loop
PWM	Pulse Width Modulator
RAM	Random Access Memory
RMII	Reduced Media Independent Interface
SE0	Single Ended Zero
SDR SDRAM	Single Data Rate Synchronous Dynamic Random Access Memory
SPI	Serial Peripheral Interface
SSI	Serial Synchronous Interface
SSP	Synchronous Serial Port
TFT	Thin Film Transistor
TTL	Transistor-Transistor Logic
STN	Super Twisted Nematic

Table 20. Abbreviations ...continued

Acronym	Description
UART	Universal Asynchronous Receiver/Transmitter
USB	Universal Serial Bus
VFP	Vector Floating Point processor

## 15. References

---

- [1] LPC3220/30/40/50 User manual UM10326:  
[http://www.nxp.com/documents/user\\_manual/UM10326.pdf](http://www.nxp.com/documents/user_manual/UM10326.pdf)
- [2] LPC3220/30/40/50 Errata sheet:  
[http://www.nxp.com/documents/errata\\_sheet/ES\\_LPC3250.pdf](http://www.nxp.com/documents/errata_sheet/ES_LPC3250.pdf)

## 16. Revision history

Table 21. Revision history

Document ID	Release date	Data sheet status	Change notice	Supersedes
LPC3220_30_40_50 v.2.1	20140624	Product data sheet	CIN 201110012I	LPC3220_30_40_50 v.2
Modifications:	<a href="#">Section 12.1 "Connecting the JTAG_NTRST pin"</a> added.			
LPC3220_30_40_50 v.2	20111020	Product data sheet	-	LPC3220_30_40_50 v.1
Modifications:	<ul style="list-style-type: none"> <li>• Corrected pin functions for pin T14 (ADIN1/TS_XM) and pin U15 (ADIN0/TS_YM) in Table 3 and Table 4.</li> <li>• Power domain for pin PLL397_LOOP corrected in Table 4.</li> <li>• Power supply domain for pins SYSX_IN and SYSX_OUT pins corrected in Table 4.</li> <li>• Power supply domain for pin VDD_OSC corrected in Table 4.</li> <li>• Description of DEBUG pin updated in Table 4.</li> <li>• Added Table 6 "Supply domains".</li> <li>• Changed V<sub>ESD</sub> to 2500 V (HBM) and 1000 V (CDM) in Table 7.</li> <li>• Power consumption for HCLK, USB, and ADC added in Table 8.</li> <li>• Parameter I<sub>DD(RTC)</sub> updated in Table 8.</li> <li>• Parameter V<sub>DD(EMC)</sub> table notes updated in Table 8.</li> <li>• Input current for bus keeper inputs added in Table 8.</li> <li>• Added power consumption data (Table 8, Table 9, and Figure 5).</li> <li>• Static memory controller: added t<sub>su(DQ)</sub> value in Table 12.</li> <li>• DDR SDRAM controller: updated t<sub>DQSS</sub> value in Table 14.</li> <li>• Minimum and maximum characterization data added for parameters t<sub>su(Q)</sub> and t<sub>h(Q)</sub> over temperature range -40 °C to +85 °C (see Table 14).</li> <li>• DDR SDRAM characteristics extended to maximum operating frequency f<sub>oper</sub> = 133 MHz (see Table 14).</li> <li>• Parameters t<sub>WB</sub>, t<sub>WHR</sub>, and t<sub>REHRBL</sub> updated in Table 18.</li> <li>• Changed data sheet status to Product data sheet.</li> <li>• Parts LPC3220FET296/01, LPC3230FET296/01, LPC3240FET296/01, LPC3250FET296/01 added.</li> </ul>			
LPC3220_30_40_50 v.1	20090206	Preliminary data sheet	-	-

## 17. Legal information

### 17.1 Data sheet status

Document status <sup>[1][2]</sup>	Product status <sup>[3]</sup>	Definition
Objective [short] data sheet	Development	This document contains data from the objective specification for product development.
Preliminary [short] data sheet	Qualification	This document contains data from the preliminary specification.
Product [short] data sheet	Production	This document contains the product specification.

[1] Please consult the most recently issued document before initiating or completing a design.

[2] The term 'short data sheet' is explained in section "Definitions".

[3] The product status of device(s) described in this document may have changed since this document was published and may differ in case of multiple devices. The latest product status information is available on the Internet at URL <http://www.nxp.com>.

### 17.2 Definitions

**Draft** — The document is a draft version only. The content is still under internal review and subject to formal approval, which may result in modifications or additions. NXP Semiconductors does not give any representations or warranties as to the accuracy or completeness of information included herein and shall have no liability for the consequences of use of such information.

**Short data sheet** — A short data sheet is an extract from a full data sheet with the same product type number(s) and title. A short data sheet is intended for quick reference only and should not be relied upon to contain detailed and full information. For detailed and full information see the relevant full data sheet, which is available on request via the local NXP Semiconductors sales office. In case of any inconsistency or conflict with the short data sheet, the full data sheet shall prevail.

**Product specification** — The information and data provided in a Product data sheet shall define the specification of the product as agreed between NXP Semiconductors and its customer, unless NXP Semiconductors and customer have explicitly agreed otherwise in writing. In no event however, shall an agreement be valid in which the NXP Semiconductors product is deemed to offer functions and qualities beyond those described in the Product data sheet.

### 17.3 Disclaimers

**Limited warranty and liability** — Information in this document is believed to be accurate and reliable. However, NXP Semiconductors does not give any representations or warranties, expressed or implied, as to the accuracy or completeness of such information and shall have no liability for the consequences of use of such information. NXP Semiconductors takes no responsibility for the content in this document if provided by an information source outside of NXP Semiconductors.

In no event shall NXP Semiconductors be liable for any indirect, incidental, punitive, special or consequential damages (including - without limitation - lost profits, lost savings, business interruption, costs related to the removal or replacement of any products or rework charges) whether or not such damages are based on tort (including negligence), warranty, breach of contract or any other legal theory.

Notwithstanding any damages that customer might incur for any reason whatsoever, NXP Semiconductors' aggregate and cumulative liability towards customer for the products described herein shall be limited in accordance with the *Terms and conditions of commercial sale* of NXP Semiconductors.

**Right to make changes** — NXP Semiconductors reserves the right to make changes to information published in this document, including without limitation specifications and product descriptions, at any time and without notice. This document supersedes and replaces all information supplied prior to the publication hereof.

**Suitability for use** — NXP Semiconductors products are not designed, authorized or warranted to be suitable for use in life support, life-critical or safety-critical systems or equipment, nor in applications where failure or malfunction of an NXP Semiconductors product can reasonably be expected to result in personal injury, death or severe property or environmental damage. NXP Semiconductors and its suppliers accept no liability for inclusion and/or use of NXP Semiconductors products in such equipment or applications and therefore such inclusion and/or use is at the customer's own risk.

**Applications** — Applications that are described herein for any of these products are for illustrative purposes only. NXP Semiconductors makes no representation or warranty that such applications will be suitable for the specified use without further testing or modification.

Customers are responsible for the design and operation of their applications and products using NXP Semiconductors products, and NXP Semiconductors accepts no liability for any assistance with applications or customer product design. It is customer's sole responsibility to determine whether the NXP Semiconductors product is suitable and fit for the customer's applications and products planned, as well as for the planned application and use of customer's third party customer(s). Customers should provide appropriate design and operating safeguards to minimize the risks associated with their applications and products.

NXP Semiconductors does not accept any liability related to any default, damage, costs or problem which is based on any weakness or default in the customer's applications or products, or the application or use by customer's third party customer(s). Customer is responsible for doing all necessary testing for the customer's applications and products using NXP Semiconductors products in order to avoid a default of the applications and the products or of the application or use by customer's third party customer(s). NXP does not accept any liability in this respect.

**Limiting values** — Stress above one or more limiting values (as defined in the Absolute Maximum Ratings System of IEC 60134) will cause permanent damage to the device. Limiting values are stress ratings only and (proper) operation of the device at these or any other conditions above those given in the Recommended operating conditions section (if present) or the Characteristics sections of this document is not warranted. Constant or repeated exposure to limiting values will permanently and irreversibly affect the quality and reliability of the device.

**Terms and conditions of commercial sale** — NXP Semiconductors products are sold subject to the general terms and conditions of commercial sale, as published at <http://www.nxp.com/profile/terms>, unless otherwise agreed in a valid written individual agreement. In case an individual agreement is concluded only the terms and conditions of the respective agreement shall apply. NXP Semiconductors hereby expressly objects to applying the customer's general terms and conditions with regard to the purchase of NXP Semiconductors products by customer.

**No offer to sell or license** — Nothing in this document may be interpreted or construed as an offer to sell products that is open for acceptance or the grant, conveyance or implication of any license under any copyrights, patents or other industrial or intellectual property rights.

**Export control** — This document as well as the item(s) described herein may be subject to export control regulations. Export might require a prior authorization from competent authorities.

**Non-automotive qualified products** — Unless this data sheet expressly states that this specific NXP Semiconductors product is automotive qualified, the product is not suitable for automotive use. It is neither qualified nor tested in accordance with automotive testing or application requirements. NXP Semiconductors accepts no liability for inclusion and/or use of non-automotive qualified products in automotive equipment or applications.

In the event that customer uses the product for design-in and use in automotive applications to automotive specifications and standards, customer (a) shall use the product without NXP Semiconductors' warranty of the product for such automotive applications, use and specifications, and (b)

whenever customer uses the product for automotive applications beyond NXP Semiconductors' specifications such use shall be solely at customer's own risk, and (c) customer fully indemnifies NXP Semiconductors for any liability, damages or failed product claims resulting from customer design and use of the product for automotive applications beyond NXP Semiconductors' standard warranty and NXP Semiconductors' product specifications.

## 17.4 Trademarks

Notice: All referenced brands, product names, service names and trademarks are the property of their respective owners.

**I<sup>2</sup>C-bus** — logo is a trademark of NXP Semiconductors N.V.

## 18. Contact information

For more information, please visit: <http://www.nxp.com>

For sales office addresses, please send an email to: [salesaddresses@nxp.com](mailto:salesaddresses@nxp.com)

## 19. Contents

<b>1</b>	<b>General description</b> . . . . .	<b>1</b>	7.7.4.1	Clocking . . . . .	35
<b>2</b>	<b>Features and benefits</b> . . . . .	<b>1</b>	7.7.4.2	Crystal oscillator . . . . .	35
<b>3</b>	<b>Applications</b> . . . . .	<b>3</b>	7.7.4.3	PLLs . . . . .	35
<b>4</b>	<b>Ordering information</b> . . . . .	<b>4</b>	7.7.4.4	Power control modes . . . . .	36
4.1	Ordering options . . . . .	4	7.7.4.5	Reset . . . . .	36
<b>5</b>	<b>Block diagram</b> . . . . .	<b>5</b>	7.8	Communication peripheral interfaces . . . . .	36
<b>6</b>	<b>Pinning information</b> . . . . .	<b>6</b>	7.8.1	UARTs . . . . .	37
6.1	Pinning . . . . .	6	7.8.1.1	Standard UARTs . . . . .	37
6.2	Pin description . . . . .	10	7.8.1.2	High-speed UARTs . . . . .	37
<b>7</b>	<b>Functional description</b> . . . . .	<b>24</b>	7.8.2	SPI serial I/O controller . . . . .	37
7.1	CPU and subsystems . . . . .	24	7.8.2.1	Features . . . . .	38
7.1.1	CPU . . . . .	24	7.8.3	SSP serial I/O controller . . . . .	38
7.1.2	Vector Floating Point (VFP) coprocessor . . . . .	24	7.8.3.1	Features . . . . .	38
7.1.3	Emulation and debugging . . . . .	24	7.8.4	I <sup>2</sup> C-bus serial I/O controller . . . . .	38
7.1.3.1	Embedded ICE . . . . .	24	7.8.4.1	Features . . . . .	39
7.1.3.2	Embedded trace buffer . . . . .	25	7.8.5	I <sup>2</sup> S-bus audio controller . . . . .	39
7.2	AHB matrix . . . . .	25	7.8.5.1	Features . . . . .	39
7.2.1	APB . . . . .	26	7.9	Other peripherals . . . . .	40
7.2.2	FAB . . . . .	26	7.9.1	General purpose parallel I/O . . . . .	40
7.3	Physical memory map . . . . .	26	7.9.1.1	Features . . . . .	40
7.4	Internal memory . . . . .	28	7.9.2	Keyboard scanner . . . . .	41
7.4.1	On-chip ROM . . . . .	28	7.9.2.1	Features . . . . .	41
7.4.2	On-chip SRAM . . . . .	28	7.9.3	Touch screen controller and 10-bit ADC . . . . .	41
7.5	External memory interfaces . . . . .	28	7.9.3.1	Features . . . . .	41
7.5.1	NAND flash controllers . . . . .	28	7.9.4	Real-Time Clock (RTC) and battery RAM . . . . .	41
7.5.1.1	Multi-Level Cell (MLC) NAND flash controller . . . . .	28	7.9.4.1	Features . . . . .	42
7.5.1.2	Single-Level Cell (SLC) NAND flash controller . . . . .	29	7.9.5	Enhanced 32-bit timers/external event counters . . . . .	42
7.5.2	SD card controller . . . . .	29	7.9.5.1	Features . . . . .	42
7.5.2.1	Features . . . . .	29	7.9.6	High-speed timer . . . . .	43
7.5.3	External memory controller . . . . .	29	7.9.6.1	Features . . . . .	43
7.6	AHB master peripherals . . . . .	30	7.9.7	Pulse Width Modulators (PWMs) . . . . .	43
7.6.1	General Purpose DMA (GPDMA) controller . . . . .	30	7.9.7.1	Features . . . . .	43
7.6.2	Ethernet MAC . . . . .	30	7.9.8	Motor control pulse width modulator . . . . .	43
7.6.2.1	Features . . . . .	31	7.9.8.1	Features . . . . .	43
7.6.3	USB interface . . . . .	31	<b>8</b>	<b>Basic architecture</b> . . . . .	<b>44</b>
7.6.3.1	USB device controller . . . . .	31	<b>9</b>	<b>Limiting values</b> . . . . .	<b>45</b>
7.6.3.2	USB host controller . . . . .	32	<b>10</b>	<b>Static characteristics</b> . . . . .	<b>46</b>
7.6.3.3	USB OTG controller . . . . .	32	10.1	Minimum core voltage requirements . . . . .	53
7.6.4	LCD controller . . . . .	33	10.2	Power supply sequencing . . . . .	53
7.6.4.1	Features . . . . .	33	10.3	Power consumption per peripheral . . . . .	53
7.7	System functions . . . . .	34	10.4	Power consumption in Run mode . . . . .	54
7.7.1	Interrupt controller . . . . .	34	10.5	ADC static characteristics . . . . .	55
7.7.2	Watchdog timer . . . . .	34	<b>11</b>	<b>Dynamic characteristics</b> . . . . .	<b>57</b>
7.7.2.1	Features . . . . .	34	11.1	Clocking and I/O port pins . . . . .	57
7.7.3	Millisecond timer . . . . .	34	11.2	Static memory controller . . . . .	57
7.7.3.1	Features . . . . .	34	11.3	SDR SDRAM Controller . . . . .	60
7.7.4	Clocking and power control features . . . . .	35			

continued >>

11.4 DDR SDRAM controller . . . . . 61

11.5 USB controller . . . . . 63

11.6 Secure Digital (SD) card interface . . . . . 63

11.7 MLC NAND flash memory controller. . . . . 64

11.8 SLC NAND flash memory controller. . . . . 65

11.9 SPI and SSP Controller . . . . . 69

11.9.1 SPI . . . . . 69

11.9.2 Timing diagrams for SPI and SSP (in SPI mode) . . . . . 70

**12 Application information. . . . . 71**

12.1 Connecting the JTAG\_NTRST pin . . . . . 71

**13 Package outline . . . . . 73**

**14 Abbreviations. . . . . 74**

**15 References . . . . . 75**

**16 Revision history. . . . . 76**

**17 Legal information. . . . . 77**

17.1 Data sheet status . . . . . 77

17.2 Definitions . . . . . 77

17.3 Disclaimers . . . . . 77

17.4 Trademarks. . . . . 78

**18 Contact information. . . . . 78**

**19 Contents . . . . . 79**

---

Please be aware that important notices concerning this document and the product(s) described herein, have been included in section 'Legal information'.

---

© NXP Semiconductors N.V. 2014. **All rights reserved.**

For more information, please visit: <http://www.nxp.com>  
 For sales office addresses, please send an email to: [salesaddresses@nxp.com](mailto:salesaddresses@nxp.com)

Date of release: 24 June 2014  
 Document identifier: LPC3220\_30\_40\_50