

TWM/TWW Series



Ceramic Housed Radial Terminal Power

The TWM/TWW series radial terminal power resistors offer significant board space savings over axial terminal products. Generated heat is also kept away from the circuit board.

They are recommended for commercial applications requiring low cost.



FEATURES

- Economical Commercial Grade for general purpose use
- Wirewound and Metal Oxide construction
- Wide resistance range
- Flameproof inorganic construction

SERIES SPECIFICATIONS

Series	Wattage	Resistance	Voltage	Element
TWW3	3	0.01-39Ω	250	Wire
TWW5	5	0.01-47Ω	350	Wire
TWW10	10	0.04-990Ω	750	Wire
TWM3	3	43-50KΩ	250	Metal oxide
TWM5	5	51-50KΩ	350	Metal oxide
TWM10	10	1000-50KΩ	750	Metal oxide

CHARACTERISTICS

Housing	Ceramic
Core	Fiberglass
Filling	Cement based
Tolerance	5% standard
Temperature coefficient	0.01-20Ω ±400ppm/°C; >20-10Ω ±350ppm/°C
Dielectric withstanding voltage	1,000VAC
Short time overload	TWW: 10x rated power for 5 sec.; TWM: 5x rated power for 5 sec.
Operating Temperature	-55°C to 275°C
Storage Temperature	15°C-35°C, humidity: 25%-75%

Derating



(continued)

TWM/TWW Series

Ceramic Housed Radial Terminal Power

DIMENSIONS

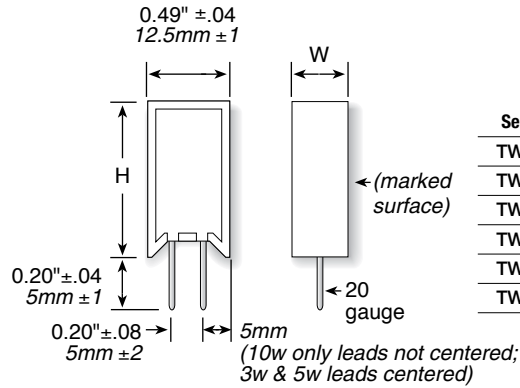

Series	Height (in./mm) ±1mm	Width
TWW3	0.98 / 25	0.33 / 8.5
TWW5	0.98 / 25	0.35 / 9
TWW10	1.97 / 50	0.35 / 9
TWM3	0.98 / 25	0.33 / 8.5
TWM5	0.98 / 25	0.35 / 9
TWM10	1.97 / 50	0.35 / 9

HOW TO ORDER

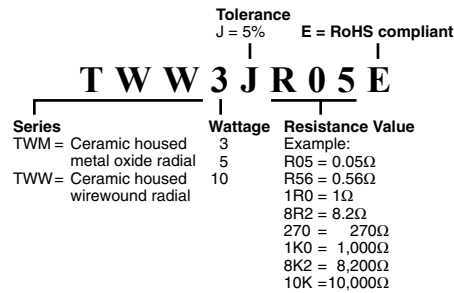

Standard part numbers for TWW series

Ohmic value	Wattage			Ohmic value	Wattage			Ohmic value	Wattage			
	Part No. Prefix Suffix	TWW3J	TWW5J		TWW10J	Part No. Prefix Suffix	TWW3J		TWW5J	TWW10J	Part No. Prefix Suffix	TWW3J
0.01	R01E	✓	✓	1.5	1R5E	✓	✓	39	39RE	✓	✓	✓
0.02	R02E	✓	✓	2.0	2R0E	✓	✓	43	43RE	✓	✓	✓
0.03	R03E	✓	✓	2.7	2R7E	✓	✓	47	47RE	✓	✓	✓
0.04	R04E	✓	✓	3.0	3R0E	✓	✓	56	56RE	✓	✓	✓
0.05	R05E	✓	✓	3.3	3R3E	✓	✓	68	68RE	✓	✓	✓
0.10	R10E	✓	✓	3.9	3R9E	✓	✓	75	75RE	✓	✓	✓
0.15	R15E	✓	✓	4.3	4R3E	✓	✓	82	82RE	✓	✓	✓
0.20	R20E	✓	✓	4.7	4R7E	✓	✓	100	100E	✓	✓	✓
0.27	R27E	✓	✓	5.6	5R6E	✓	✓	150	150E	✓	✓	✓
0.30	R30E	✓	✓	6.8	6R8E	✓	✓	200	200E	✓	✓	✓
0.33	R33E	✓	✓	7.5	7R5E	✓	✓	270	270E	✓	✓	✓
0.39	R39E	✓	✓	8.2	8R2E	✓	✓	300	300E	✓	✓	✓
0.43	R43E	✓	✓	10	10RE	✓	✓	330	330E	✓	✓	✓
0.47	R47E	✓	✓	15	15RE	✓	✓	390	390E	✓	✓	✓
0.56	R56E	✓	✓	20	20RE	✓	✓	430	430E	✓	✓	✓
0.68	R68E	✓	✓	22	22RE	✓	✓	470	470E	✓	✓	✓
0.75	R75E	✓	✓	27	27RE	✓	✓	560	560E	✓	✓	✓
0.82	R82E	✓	✓	30	30RE	✓	✓	680	680E	✓	✓	✓
1.0	1R0E	✓	✓	33	33RE	✓	✓	750	750E	✓	✓	✓
								820	820E	✓	✓	✓

Standard part numbers for TWM series

Ohmic value	Wattage			Ohmic value	Wattage		
	Part No. Prefix Suffix	TWM3J	TWM5J		TWM10J	Part No. Prefix Suffix	TWM3J
43	43RE	✓	✓	750	750E	✓	✓
47	47RE	✓	✓	820	820E	✓	✓
56	56RE	✓	✓	1000	1K0	✓	✓
68	68RE	✓	✓	1500	1K5	✓	✓
75	75RE	✓	✓	2000	2K0	✓	✓
82	82RE	✓	✓	2700	2K7	✓	✓
100	100E	✓	✓	3000	3K0	✓	✓
150	150E	✓	✓	3300	3K3	✓	✓
200	200E	✓	✓	3900	3K9	✓	✓
270	270E	✓	✓	4300	4K3	✓	✓
300	300E	✓	✓	4700	4K7	✓	✓
330	330E	✓	✓	5600	5K6	✓	✓
390	390E	✓	✓	6800	6K8	✓	✓
430	430E	✓	✓	7500	7K5	✓	✓
470	470E	✓	✓	8200	8K2	✓	✓
560	560E	✓	✓	10000	10K	✓	✓
680	680E	✓	✓				