

Potentiometers

Molded composition



Ohmite molded composition potentiometers are available in various models for applications in military devices, industrial equipment and in equipment requiring a convenient resistance control device.

FEATURES

- Low noise, smooth operation
- In accordance with “Mil” RV4N, RV4L, RV6L, RV6N, 2RV7N types
- RoHS compliant; non-RoHS version unavailable.



SERIES SPECIFICATIONS

Model	Watts	Ohmic range	Behind panel (in./mm)	Diameter (in./mm)	Rotation	Voltage (RMS)
AS	0.5	50-5M	0.703/17.9	0.50/12.7	295° ±5°	350
ASM	0.5	50-5M	0.703/17.9	0.50/12.7	295° ±5°	350
CA	2.0	50-5M	0.625/15.9	1.16/29.4	312° ±3°	500
CB	2.0	50-5M	0.625/15.9	1.16/29.4	312° ±3°	500
CU	2.0	50-5M	0.625/15.9	1.16/29.4	312° ±3°	500
CCU	2.0	50-5M	1.266/32.1	1.16/29.4	312° ±3°	500
CLU	2.0	50-5M	0.625/15.9	1.16/29.4	312° ±3°	500
CMU	2.0	50-5M	0.625/15.9	1.16/29.4	312° ±3°	500

CHARACTERISTICS

Derating linear from 100% at +70°C to 0% at +120°C

Operating temp. range -55°C to 120°C

Construction Elements molded into a single, integral structure. Metal cover protects and shields the internal parts.

Sealing synthetic resin containing non-mercurial fungicide

Product life Since all rheostats/potentiometers are electro-mechanical devices, they are subject to mechanical wear and, therefore, have a finite life.

(continued)

Potentiometers

Molded composition

DIMENSIONS

(iin./mm)

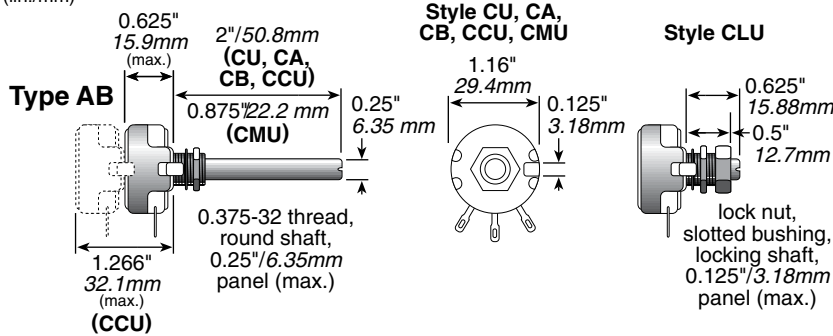

Model	Watts	Behind panel	Diameter	Rotation
AS	0.5	0.703/17.9	0.50/12.7	295° ±5°
ASM	0.5	0.703/17.9	0.50/12.7	295° ±5°
CA	2.0	0.625/15.9	1.16/29.4	312° ±3°
CB	2.0	0.625/15.9	1.16/29.4	312° ±3°
CU	2.0	0.625/15.9	1.16/29.4	312° ±3°
CCU	2.0	1.266/32.1	1.16/29.4	312° ±3°
CLU	2.0	0.625/15.9	1.16/29.4	312° ±3°
CMU	2.0	0.625/15.9	1.16/29.4	312° ±3°

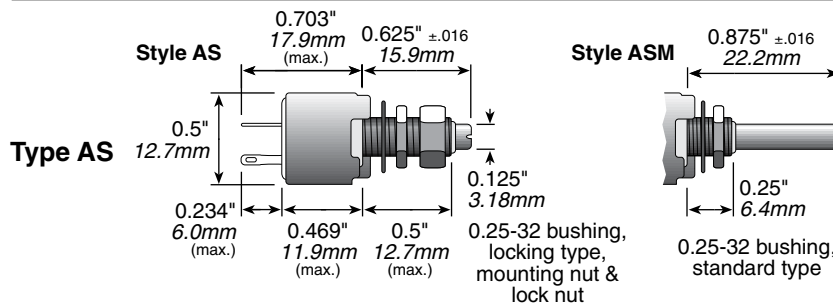

ORDERING INFORMATION

Ohmic value	MIL Designation			Part No.										
	Prefix	Suffix	Part No. Prefix Suffix	CMU	CU	CA	CB	CLU	CCU	RV6LAYSA	RV6NAVSD	RV6NAVSD	RV6NAVSD	RV6NAVSD
50	500A	5001		✓	✓			✓						
100	101A	1011		✓	✓			✓		AS3601E	ASM6661E			
150	151A	1511		✓	✓			✓						
250	251A	2511		✓	✓			✓		AS3602E	ASM6662E			
350	351A	3511		✓	✓			✓						
500	501A	5011		✓	✓			✓		AS3603E	ASM6663E			
750	751A	7511		✓	✓			✓						
1,000	102A	1021		✓	✓			✓		AS3604E	ASM6664E			
1,500	152A	1521		✓	✓			✓						
2,500	252A	2521		✓	✓			✓		AS3605E	ASM6665E			
3,500	352A	3521		✓	✓			✓						
5,000	502A	5021		✓	✓			✓		AS3606E	ASM6666E			
7,500	752A	7521		✓	✓			✓						
10,000	103A	1031		✓	✓		✓	✓		AS3607E	ASM6667E			
15,000	153A	1531		✓	✓		✓	✓						
25,000	253A	2531		✓	✓		✓	✓		AS3608E	ASM6668E			
35,000	353A	3531		✓	✓		✓	✓						

✓ = Standard values; check availability
 * add "-E" for RoHS-compliant lead-free zinc-nickel plated product