

Ultra Subminiature Basic Switch D2LS

Compact Surface-mounting Switches ideal for applications requiring long service life.

- High-operating force version with long service life is available. (OF: 1.2 N, Durability: 5,000,000 operations)
- Compact size: 8.6 x 4.8 x 3.0 mm. (W x D x H)
- Clear click feeling.
- Embossed tape packaging for automated mounting.
- RoHS Compliant.

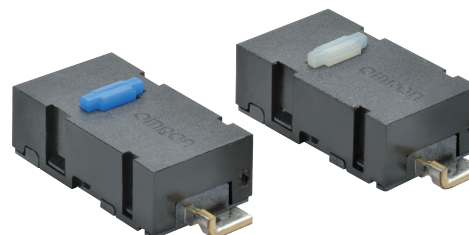

NEW

Ordering Information

Operating Force (OF)	Button Color	Model	Quantity per reel*
1.2 N (122 gf)	White	D2LS-11	2000 pcs
0.6 N (61 gf)	Blue	D2LS-21	

Model Number Legend

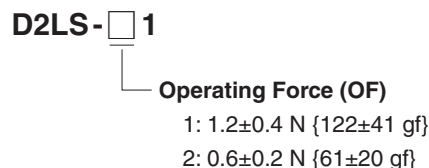

Contact Form (SPST-NO)

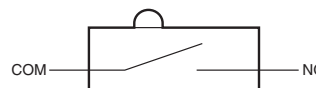

Specifications

■ Ratings

Rated Voltage	Resistive load
6 VDC	1 mA

Note: The ratings apply under the following test conditions:
 Ambient Temperature = 20±2°C
 Ambient Humidity = 65±5%
 Operating frequency = 30 operations/min.

■ Contact Specifications

Specification	Crossbar
Material	Silver
Gap (Standard value)	0.4 mm
Minimum Applicable Load (Reference Value - See note)	15 µA at 3 VDC

Note: Minimum applicable loads are indicated by N standard reference values. This value represents the failure rate at a 60% (λ_{60}) reliability level (JIS C5003).

The equation $\lambda_{60}=0.5 \times 10^{-6}/\text{operations}$ indicates that a failure rate of 1/2,000,000 operations can be expected at a reliability level of 60%.

■ Characteristics

Operating speed	1 to 500 mm/second
Operating frequency	Mechanical / Electrical: 300 operations per minute max.
Contact resistance	100 mΩ max.
Insulation resistance	100 MΩ min. at 500 VDC
Dielectric strength	600 VAC 50/60 Hz for 1 minute between terminals of the same polarity
Vibration resistance (See note 2)	Malfunction: 10 to 55 Hz, 1.5 mm double amplitude
Shock resistance (See note 2)	Destruction: 1,000 m/s ² (approx. 100G) max. Malfunction: 300 m/s ² (approx. 30 g min.) max.
Degree of protection	IP40
Ambient operating temperature	-25° to 85°C (at 60% RH max.) with no icing or condensation
Ambient operating Humidity	85% RH max. (for 5° to 35°C)
Service life (Consult Omron for test conditions)	Mechanical / Electrical: 5,000,000 operations min. at 300 operations/minute.
Weight	Approx. 0.16 g (pin plunger models)

Note: 1. Data shown are of initial value.

2. The values are measured at the free position and total travel position. Contact opening or closing time is within 1 ms max.

Dimensions

■ Dimensions and Operating Characteristics

Note: Unless otherwise specified, all units are in millimeters and a tolerance of ±0.4 mm applies to all dimensions

D2LS-11
D2LS-21

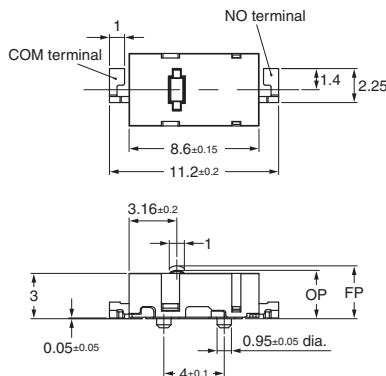
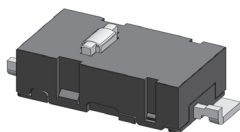

PCB land dimensions (reference)
(TOP VIEW)

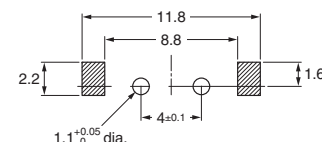

Characteristics	D2LS-11	D2LS-21
OF	1.2 ± 0.4 N (122 ± 41 gf)	0.6 ± 0.2 N (61 ± 20 gf)
RF min.		0.15 N (15 gf)
OT min.		0.1 mm
MD max.		0.12 mm
OP		3.2 ± 0.2 mm
FP max.		3.5 ± 0.2 mm

■ Packaging Specifications (Unit: mm)

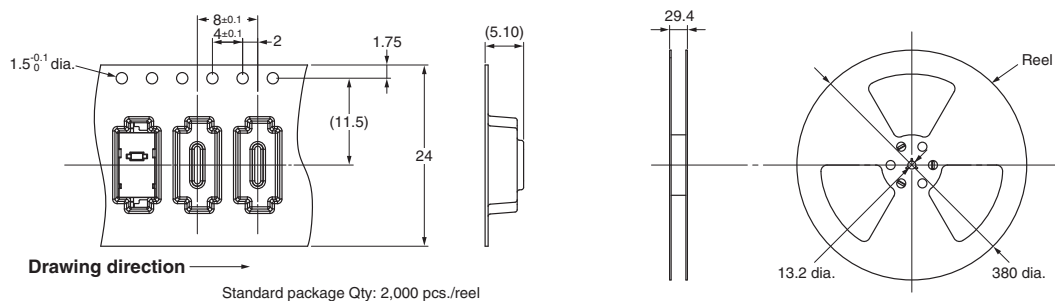

Precautions

Be sure to read the precautions and information common to all Snap Action and Detection Switches, contained in the Technical User's Guide, "Snap Action Switches, Technical Information" for correct use.

■ Cautions

Use the switch within the rated voltage and current ratings, otherwise the switch may have a shortened life expectancy, radiate heat or burn out. This particularly applies to the instantaneous voltages and currents when switching.

Application Environment

Do not use the switch in locations that are subject to toxic gas, silicon, excessive dust, excessive dirt, high temperatures, high humidity, sudden temperature changes, water splashes or oil splashes.

Otherwise, damage resulting by faulty contact of the switch contacts, corrosion or other causes, or other functional faults, may occur.

Soldering- General Precautions

Before soldering the switch on a multilayer PCB, test to confirm that soldering can be performed properly. Otherwise, the switch may be deformed by the soldering heat on the patterns or lands of the multilayer PCB.

Do not solder the switch more than twice, including rectification soldering. An interval of five minutes is required between the first and second soldering.

■ Correct Use

Reflow Soldering (Surface Mounting)

Solder the terminals within the heating curve shown in the following diagram.

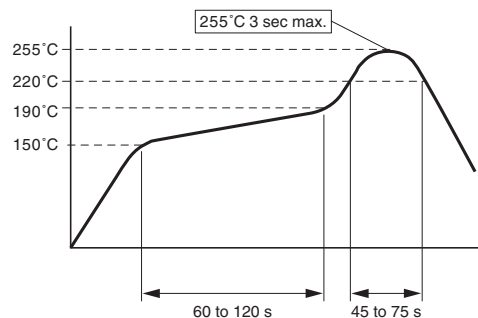

The peak temperature may vary depending on the reflow bath used. Confirm the conditions beforehand.

Manual Soldering

Soldering Temperature: 350 °C max. at the tip of the soldering iron.
Soldering Time: 3 seconds max.

Washing

The switch is not sealed and cannot be washed. Doing so will cause the washing agent, together with flux or dust particles on the PCB, to enter the switch, resulting in malfunction.

All sales are subject to Omron Electronic Components LLC standard terms and conditions of sale, which can be found at http://www.components.omron.com/components/web/webfiles.nsf/sales_terms.html

ALL DIMENSIONS SHOWN ARE IN MILLIMETERS.

To convert millimeters into inches, multiply by 0.03937. To convert grams into ounces, multiply by 0.03527.

OMRON[®]
OMRON ELECTRONIC
COMPONENTS LLC
847-882-2288

OMRON ON-LINE

Global - <http://www.omron.com>
USA - <http://www.components.omron.com>