

Miniature Battery Connectors XD2B

Miniature Battery Connectors with 13.2 mm Width and 2.6 mm Depth.

- Greatly reduced board footprint with a depth of 2.6 mm.
- Use for mid mount board, height on PCB 1.4 mm.
- Three models available for different battery connection applications

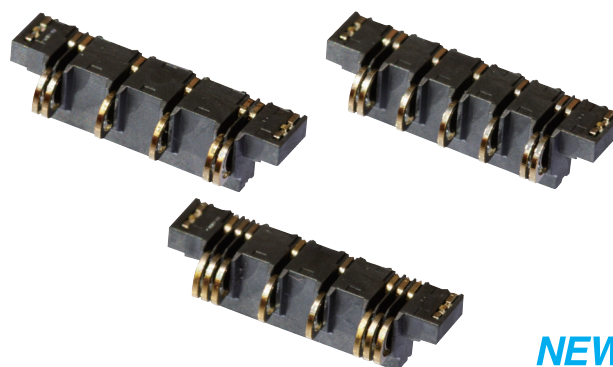

NEW

Ordering Information

Model	Appearance	Number of Pads	Number of contact pins	Battery PAD		Quantity per reel (unit)
XD2B-0406-26A		4	6	 4PAD Type		2,000
XD2B-0507-20A		5	7	 5PAD Type		
XD2B-0408-23A		4	8	 4PAD Type (High Current)		

Model Number Legend

XD2B- -

1 2 3 4

- | | | | |
|--|--|--|--------------------------------|
| <p>1. Number of Pads</p> <p>04: 4 pads</p> <p>05: 5 pads</p> | <p>2. Number of contact pins</p> <p>06: 6 pins</p> <p>07: 7 pins</p> <p>08: 8 pins</p> | <p>3. Pad pitch</p> <p>20: 2.0 mm</p> <p>23: 2.3 mm</p> <p>26: 2.65 mm</p> | <p>4. Plating</p> <p>A: Au</p> |
|--|--|--|--------------------------------|

■ Ratings and Characteristics

Rated current (See note 1)	XD2B-0406-26A	2 A
	XD2B-0507-20A	
	XD2B-0408-23A	3 A
Rated voltage	5 VDC	
Contact resistance (See note 2)	1Pin: 70 mΩ max.	
	2Pin: 35 mΩ max.	
	3Pin: 35 mΩ max.	
Operation durability	5,000 times	
Operating temperature	- 30 to 85°C (with no icing or condensation)	

- Note:**
1. The rated current assumes that the end pins (▲) are used as the power lines.
 2. The contact resistance of pins marked ▲ is 35 mΩ. The contact resistance of the other pins is 70 mΩ



■ Materials and Finish

Housing	LCP resin (UL94V-0) / black
Contacts	Nickel alloy / nickel base, gold plated
Hold-down	Brass / nickel base, gold plated.

Dimensions

XD2B-0406-26A

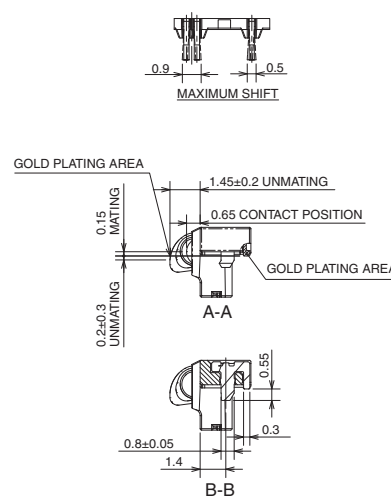
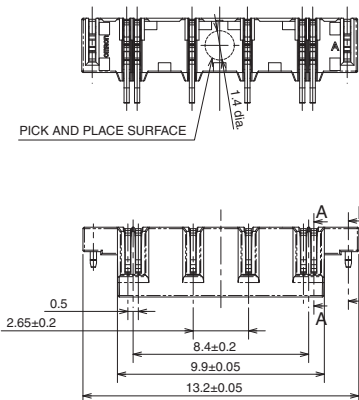
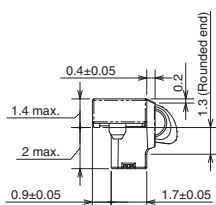
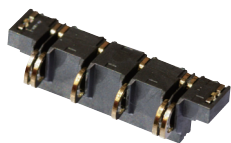

PCB Mating Dimensions (TOP VIEW)

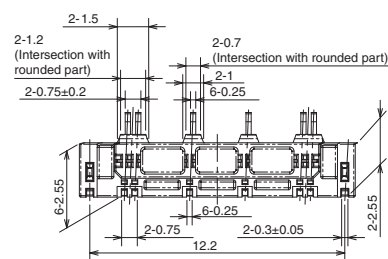
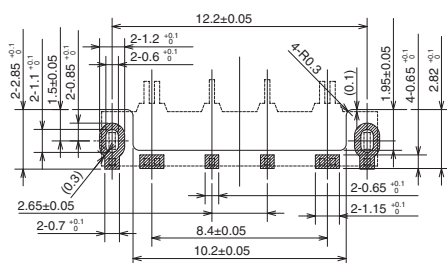

Reference Pad Dimensions

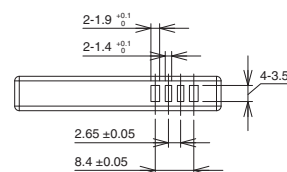

- Precautions
1. Coplanarity: 0.1 max.
 2. Tolerance: ±0.1 unless otherwise specified.

XD2B-0507-20A

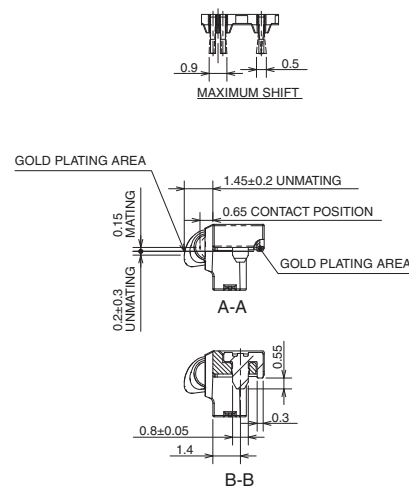
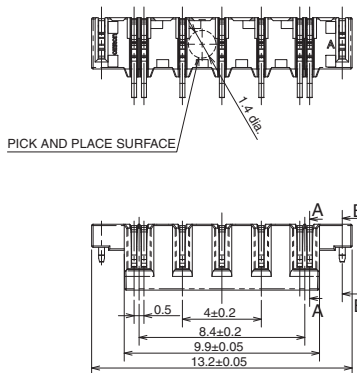
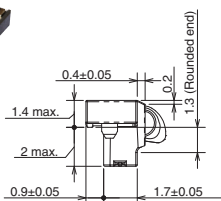
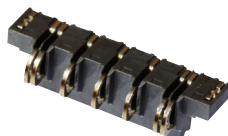

PCB Mating Dimensions (TOP VIEW)

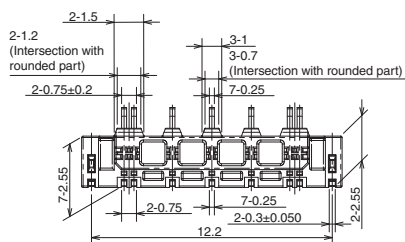
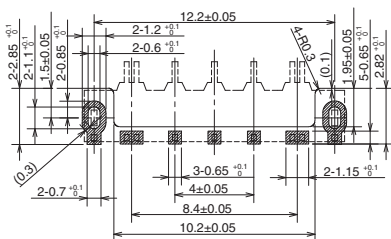

Reference Pad Dimensions

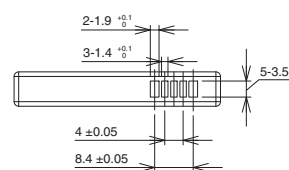

- Precautions
1. Coplanarity: 0.1 max.
 2. Tolerance: ±0.1 unless otherwise specified.

XD2B-0408-23A

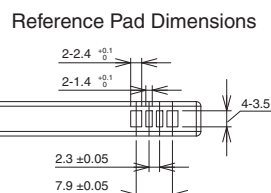
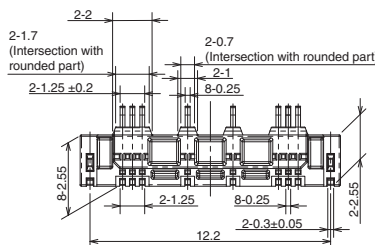
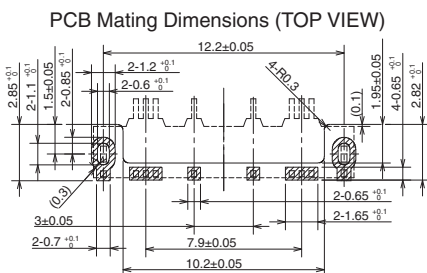
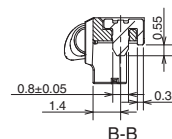
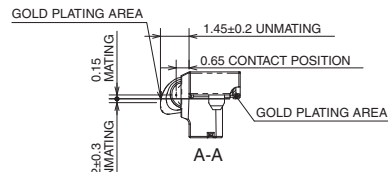
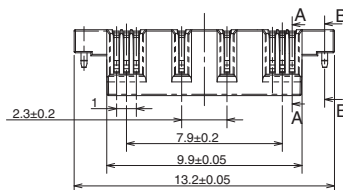
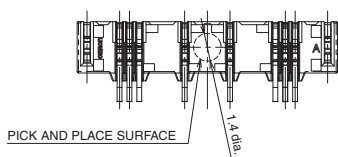
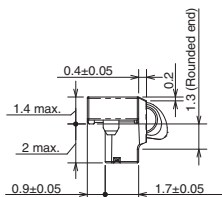

- Precautions
1. Coplanarity: 0.1 max.
 2. Tolerance: ±0.1 unless otherwise specified.

Precautions

Correct Use

Design Considerations

Design the case so that the contacts are not subject to a load from the top when the battery is inserted. Not doing so may cause the contacts to deform, resulting in contact failure.

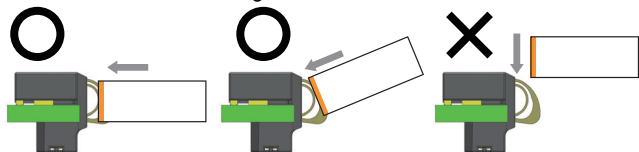

Use the following specifications for plating on the battery pad surface; nickel base with gold plating or a thickness of 1.5 μm or greater.

Use a metal mask thickness of between 0.12 to 0.15 mm. The recommended metal mask opening ratio is 90% of the processing dimensions on the PCB in the external dimensions diagram.

Design the case so that the contacts are located as shown in the outline drawing when the battery is mated.

Mounting

Use reflow conditions that are within the ranges specified by Omron. However, reflow conditions depend on the type of solder, manufacturer, quantity, board size and other mounting materials and conditions. Always confirm mounting conditions before actual application.

Do not mount the connectors with manual soldering. If the end of the soldering iron comes into contact with the connector, deformation may result.

Do not perform the following operations during mounting. Doing so may damage the connector, resulting in contact failure or mounting failure.

- Stack boards to which the connectors are mounted.
- Touch the contact section or hold-downs with tweezers or other objects.
- Apply outward force on the contact sections.

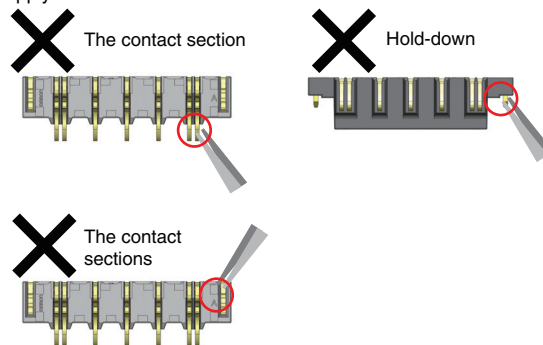

Operation

Do not apply excessive force to the contacts. Doing so may cause the contacts to deform or the contact plating to peel, resulting in contact failure.

Do not touch contacts directly with your fingers or other parts of your body. Doing so may cause the contacts to deform, resulting in contact failure.

All sales are subject to Omron Electronic Components LLC standard terms and conditions of sale, which can be found at http://www.components.omron.com/components/web/webfiles.nsf/sales_terms.html

ALL DIMENSIONS SHOWN ARE IN MILLIMETERS.
To convert millimeters into inches, multiply by 0.03937. To convert grams into ounces, multiply by 0.03527.

OMRON[®]

**OMRON ELECTRONIC
COMPONENTS LLC**

55 E. Commerce Drive, Suite B
Schaumburg, IL 60173

847-882-2288

OMRON ON-LINE

Global - <http://www.omron.com>

USA - <http://www.components.omron.com>