

MEMS Mass Flow Sensor D6F-P

A Compact, High-performance Flow Sensor with Dust Segregation Structure.

- Built in Dust Segregation System (DSS) with cyclone flow structure, diverts particulates from sensor element.
- High resolution and repeatability, even at low flow rates.
- Barbed ports with connector or PCB terminals, or manifold mount with connector versions.
- Built in voltage regulator, temperature compensation and amplified output. Measure up to 200 LPM with a bypass setup.
- High accuracy of $\pm 5\%$ FS.
- RoHS Compliant

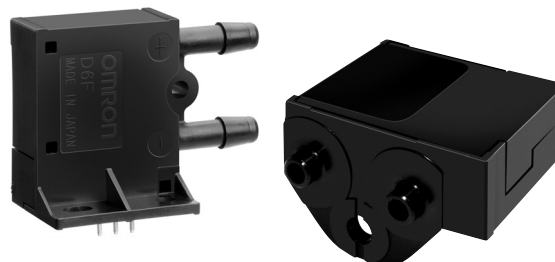

Ordering Information

Description	Case	Calibration Gas (See note 1.)	Flow Range	Mounting Method	Connection	Model
Flow Sensor	PBT	Air (See note 2.)	0-0.1 LPM	Flange mount	Lead terminals	D6F-P0001A1
			0-1 LPM		Connector	D6F-P0010A1
				Manifold mount	Connector	D6F-P0010AM2
Cable Connector Assembly	---	---	---	---	---	D6F-CABLE2

Note: 1. Can be calibrated for different gas types. Consult your Omron representative.

2. Dry gas must not contain large particles, eg dust, oil, mist.

3. Cable Assembly "D6F-CABLE2", used with D6F-P0010A2 and D6F-P0010AM2, is sold separately.

Specifications

Characteristics

Models	D6F-P0001A1	D6F-P0010A1	D6F-P0010A2	D6F-P0010AM2
Flow Range (See note 1.)	0 to 0.1 L/min.	0 to 1 L/min.		
Calibration Gas (See note 2.)	Air			
Flow Port Type	barbed fitting maximum outside dia. 4.9 mm			manifold mount
Electrical Connection	Lead terminal		Connector (3 wire)	
Power Supply	4.75 to 9.45 VDC			
Current Consumption	Max. 15 mA (no load, Vcc = 5 VDC)			
Operating Output Voltage	0.5 to 2.5 VDC			
Output Voltage Limits (Min and Max.)	0 VDC min. and 3.1 VDC max. (Lead resistance 10 k Ω)			
Accuracy and Temperature Characteristics	$\pm 5\%$ F.S. max. of detected characteristics at 25 °C, within -10 to +60 °C (typical test results within $\pm 2\%$ F.S.)			
Repeatability (Reference (typical))	$\pm 1.0\%$ F.S.	$\pm 0.4\%$ F.S.		
Case Material	PBT			
Degree of Protection	IP40			
Withstand Pressure	50 kPa (7 psi)			
Pressure Drop (Reference (typical))	0.19 kPa			0.48 kPa
Operating Temperature	-10 to +60°C (1 LPM versions) and -33 to +75°C (0.1 LPM version) with no icing or condensation (Storage: -40 to +80°C with no icing or condensation)			
Operating Humidity	35 to 85% RH with no icing or condensation (Storage: 35 to 85% RH with no icing or condensation)			
Insulation Resistance	20 M Ω (500 VDC between lead terminal and the case)			
Dielectric Strength	500 VAC, 50/60 Hz for 1 minute. (Leakage current typ. Max. 1mA) between lead terminals and case.			
Weight	8.5 g			8.0 g
Response Time (Reference (typical))	150 msec			

Note: 1. Volumetric flow rate at 0°C, 101.3 kPa.

2. Dry gas. (must not contain large particles, dust, oil, mist)

Absolute Maximum Rating

Item	Symbol	Rating	Unit
Power supply voltage	Vcc	10	VDC
Output voltage	Vout	4.0	VDC

Output Voltage Characteristics

D6F-P0001A

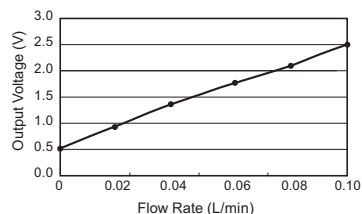

D6F-P0010A

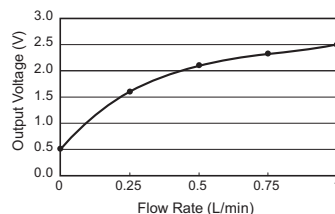

D6F-P0001A

Flow Rate (LPM)	0.00	0.02	0.04	0.06	0.08	0.10
Output Voltage (VDC)	0.50 ± 0.10	0.90 ± 0.10	1.30 ± 0.10	1.70 ± 0.10	2.10 ± 0.10	2.50 ± 0.10

D6F-P0010A

Flow Rate (LPM)	0.00	0.25	0.50	0.75	1.00
Output Voltage (VDC)	0.50 ± 0.10	1.60 ± 0.10	2.10 ± 0.10	2.31 ± 0.10	2.50 ± 0.10

- Note:**
1. Mass flow converted into volumetric flow rate, SLM (standard liters per minute) at 0°C, 1 atmosphere.
 2. 0 to 0.5 VDC output indicates a negative flow direction.
 3. Measurement condition: Power supply voltage of 5.0 ± 0.1VDC, ambient temperature of 25 ± 5 °C and ambient humidity of 35% to 75% RH.

Repeatability. (Typical test results)

(5 Samples, D6F-P0010A, repeated 10 times each)

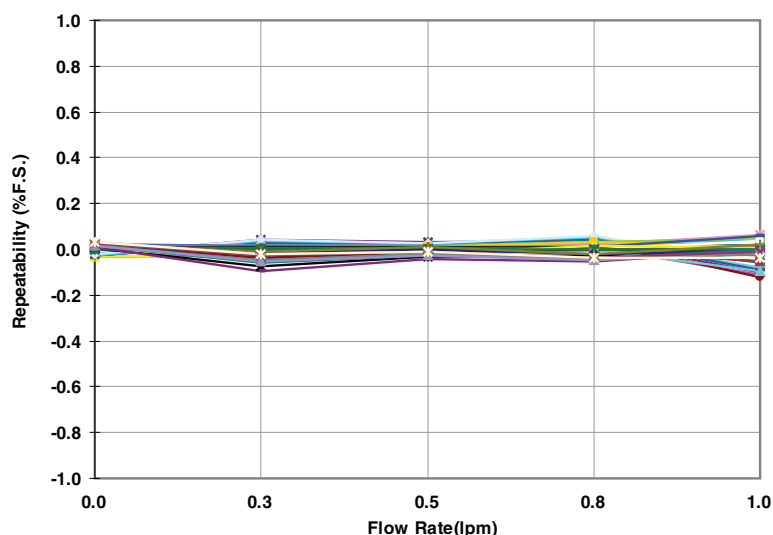

Dimensions

Note: All units are in millimeters unless otherwise indicated.

Lead terminals with Flange Mount D6F-P0001A1 / D6F-P0010A1

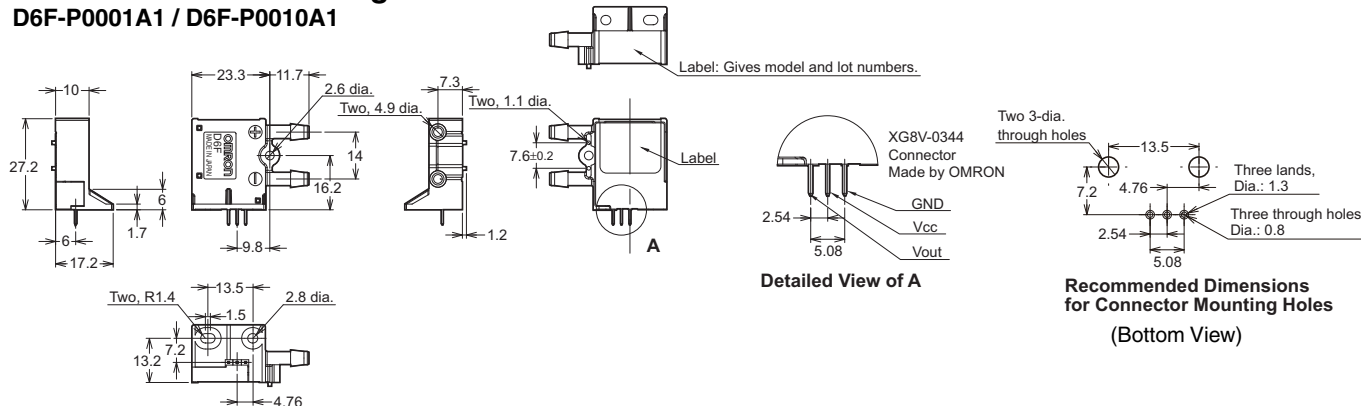

Connector with Flange Mount D6F-P0010A2

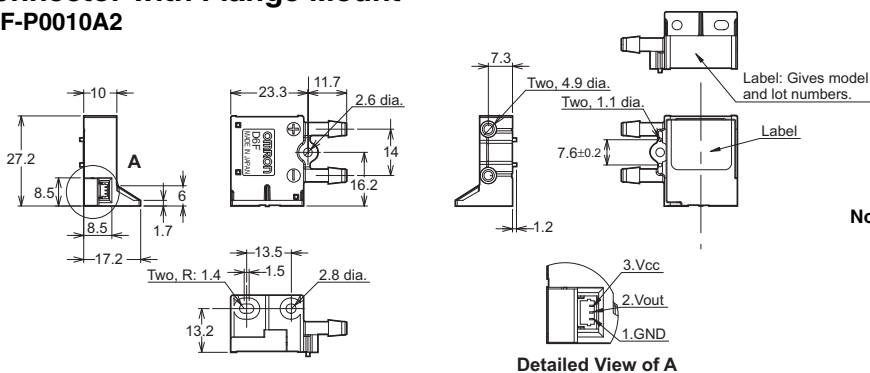

- Note:
- Use M3 or M2.6 pan screw or tapping screw with an equal diameter for installation. And bind tight with 0.59N-m or less torque.
 - Use an attached connector. Manufactured by JST Mfg Co., Ltd. (Japan) for A2 and AM2 types.
 - Pressure welding connector
 - Socket: 03SR-3S
 - Wire: AWG#30
 - OR
 - Crimp type connector
 - Contact: SSH-003T-P0.2]
 - Wire: AWG#32 to #28
 - Housing: SHR-03V-S
 - O-rings are not attached. 4mm ID tube recommended for D6F-P0010A1 and D6F-P0010A2 types.

Connector with Manifold Mount D6F-P0010AM2

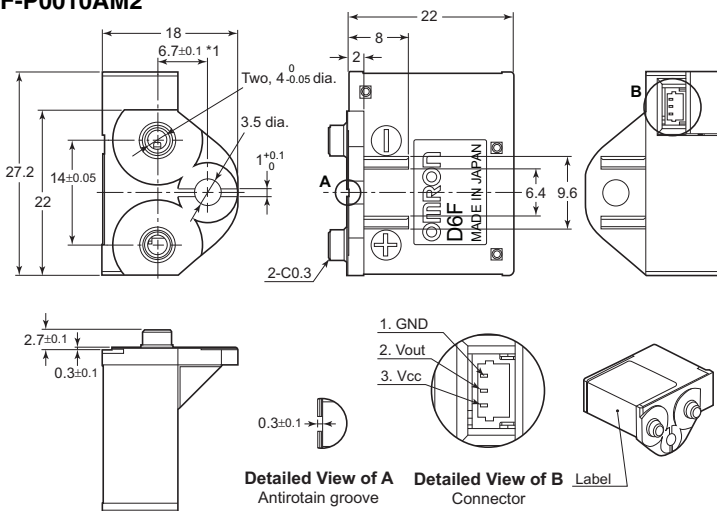

Applicable Cable for D6F-P0010A□2 (Optional - sold separately) part number: D6F-CABLE2

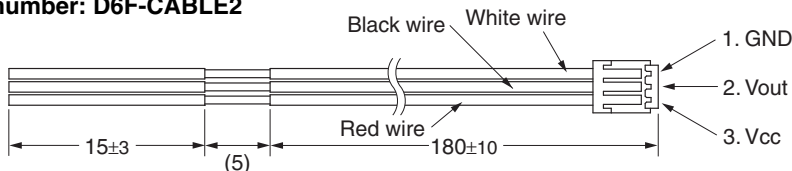

Packaging

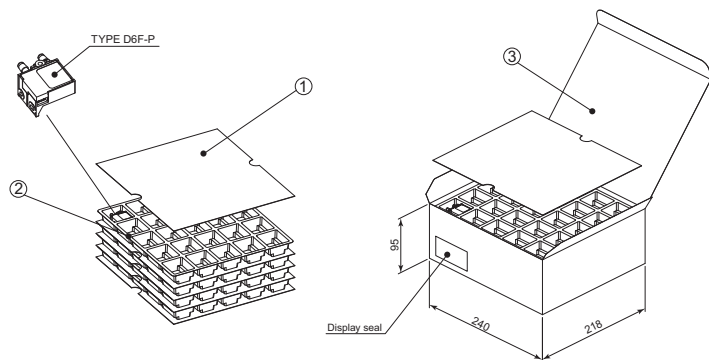

No.	Item	Material
1	Sock liner	CCNB
2	Tray (25pcs)	Polyethylene
3	Box (100 pcs)	CCNB

Application Information and Examples

■ Bidirectional Dust Segregation System

The D6F-P series has a patented dust segregation design. The flow path incorporates dual centrifugal chambers, in which particulate matter follows in the outer path, away from the MEMS sensor chip regardless of the flow direction. Note, standard products are calibrated for unidirectional flow, as indicated in note 3 of the “Output Characteristics” table, above. Contact Omron for bidirectional calibration options.

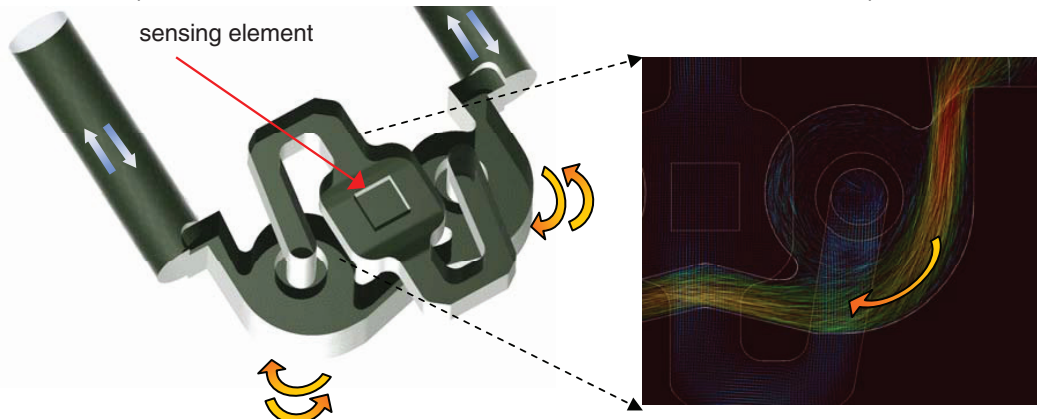

Bypass Setup

When used in a bypass set-up, as illustrated below, the D6F-P mass flow sensors can measure flow rates far beyond the 1 LPM in-line rating. The pressure differential required to pull airflow through the sensor can be accomplished by installing a flow restrictor between the two ports or through the use of a flow cross in large ducts, as shown in the HVAC application.

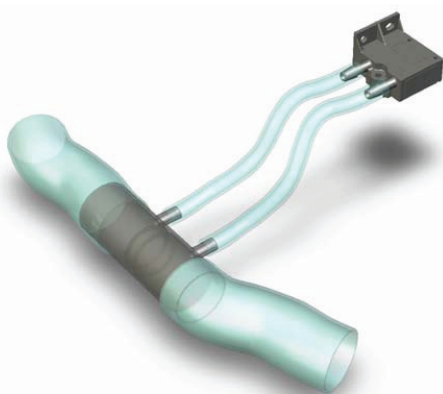

HVAC Application

The D6F-P mass flow sensor is ideal for damper control in variable air volume systems, where low flow rates are difficult to measure with differential pressure sensors.

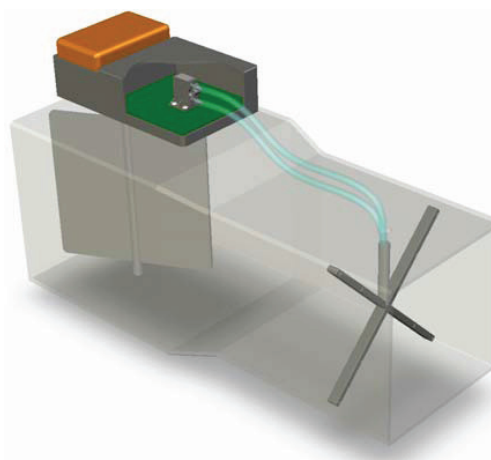

Note: Be sure to read the precautions and information common to all D6F sensors, contained in the Technical User's Guide, “D6F Technical Information” for correct use.



All sales are subject to Omron Electronic Components LLC standard terms and conditions of sale, which can be found at http://www.components.omron.com/components/web/webfiles.nsf/sales_terms.html

ALL DIMENSIONS SHOWN ARE IN MILLIMETERS.
To convert millimeters into inches, multiply by 0.03937. To convert grams into ounces, multiply by 0.03527.

OMRON[®]

**OMRON ELECTRONIC
COMPONENTS LLC**

55 E. Commerce Drive, Suite B
Schaumburg, IL 60173

847-882-2288

OMRON ON-LINE

Global - <http://www.omron.com>

USA - <http://www.components.omron.com>

Cat. No. X305-E-1a

09/13

Specifications subject to change without notice

Printed in USA