

60/90/120/180/240-W Models

Improved Versions of Standard-type Power Supplies without Indication Monitor.



- Safety standards:
 - UL508/60950-1,
 - CSA C22.2 No. 107.1/60950-1
 - EN 50178 (= VDE0160)
- Mount to DIN Rail.
- Complies with SEMI F47-0200 (200-VAC input).
- RoHS-compliant.

* Refer to *Safety Precautions* on page 12.

Model Number Structure

Model Number Legend

Note: Refer to *List of Models in Ordering Information*, below.

S8VE-

| | | | | |
|---|---|---|----|----|
| □ | □ | □ | 24 | -□ |
| 1 | 2 | 3 | | |

1. Power Ratings

060: 60 W
090: 90 W
120: 120 W
180: 180 W
240: 240 W

2. Output voltage

24: 24 V

3. Terminal Block Form

None: Screw terminal block
F: Screwless terminal block

Ordering Information

List of Models

Note: For details on normal stock models, contact your nearest OMRON representative.

| Power ratings | Input voltage | Output voltage | Output current | Model number (screw terminal block) | Model number (screwless terminal block) |
|---------------|----------------|----------------|----------------|--|--|
| 60 W | 100 to 240 VAC | 24 V | 2.5 A | S8VE-06024 | S8VE-06024-F |
| 90 W | | | 3.75 A | S8VE-09024 | S8VE-09024-F |
| 120 W | | | 5 A | S8VE-12024 | S8VE-12024-F |
| 180 W | | | 7.5 A | S8VE-18024 | S8VE-18024-F |
| 240 W | | | 10 A | S8VE-24024 | S8VE-24024-F |

Specifications

Ratings/Characteristics

| Item | Power ratings | 60 W | 90 W | |
|----------------------|--|---|--|------------|
| Efficiency (typical) | | 78% min. | 80% min. | |
| Input | Voltage *1 | 100 to 240 VAC (85 to 264 VAC) | | |
| | Frequency *1 | 50/60 Hz (47 to 450 Hz) | | |
| | Current | 100-V input | 1.7 A max. | 2.3 A max. |
| | | 200-V input | 1.0 A max. | 1.4 A max. |
| | Power factor | --- | | |
| | Harmonic current emissions | Conforms to EN61000-3-2 | | |
| | Leakage current | 100-V input | 0.5 mA max. | |
| 200-V input | | 1.0 mA max. | | |
| Inrush current *2 | 100-V input | 25 A max. (for a cold start at 25°C) | | |
| | 200-V input | 50 A max. (for a cold start at 25°C) | | |
| Output | Voltage adjustment range *3 | -10% to 15% (with V. ADJ) | | |
| | Ripple | 2.0% (p-p) max. (at rated input/output voltage) | | |
| | Input variation influence | 0.5% max. (at 85- to 264-VAC input, 100% load) | | |
| | Load variation influence (rated input voltage) | 1.5% max. (with rated input, 0 to 100% load) | | |
| | Temperature variation influence | 0.05%/°C max. | | |
| | Startup time *2 | 1,000 ms max. (at rated input/output voltage) | | |
| | Hold time *2 | 20 ms min. (at rated input/output voltage) | | |
| Additional functions | Overload protection *2 | 105% to 160% of rated load current, voltage drop, intermittent, automatic reset | | |
| | Overvoltage protection *2, *4 | Yes | | |
| | Parallel operation | No | | |
| | Series operation | Yes for up to 2 Power Supplies (with external diode) | | |
| Other | Operating ambient temperature | Refer to the derating curve in <i>Engineering Data (60-W, 90-W, 120-W, 180-W, and 240-W Models)</i> . (with no icing or condensation) | | |
| | Storage temperature | -25 to 65°C | | |
| | Operating ambient humidity | 25% to 85% (Storage humidity: 25% to 90%) | | |
| | Dielectric strength | 3.0 kVAC for 1 min. (between all inputs and outputs; detection current: 20 mA) | | |
| | | 2.0 kVAC for 1 min. (between all inputs and PE terminals; detection current: 20 mA) | | |
| | | 1.0 kVAC for 1 min. (between all outputs and PE terminals; detection current: 30 mA) | | |
| | Insulation resistance | 100 MΩ min. (between all outputs and all inputs/ PE terminals) at 500 VDC | | |
| | Vibration resistance | 10 to 55 Hz, 0.375-mm single amplitude for 2 h each in X, Y, and Z directions | | |
| | | 10 to 150 Hz, 0.35-mm single amplitude (5 G max.) for 80 min each in X, Y, and Z directions | | |
| | Shock resistance | 150 m/s ² , 3 times each in ±X, ±Y, and ±Z directions | | |
| | Output indicator | Yes (color: green) | | |
| | EMI | Conducted Emissions | Conforms to EN61204-3 EN55011 Class A and based on FCC Class A | |
| | | Radiated Emissions | Conforms to EN61204-3 EN55011 Class A | |
| | EMS | Conforms to EN61204-3 high severity levels | | |
| | Approved standards | UL: UL508 (Listing), UL60950-1 cUL: CSA C22.2 No.107.1 cUR: CSA No.60950-1 EN/VDE: EN50178 (= VDE0160) According to VDE 0106/P100, IP20 (except terminal block) | | |
| SEMI | F47-0200 (200-VAC input) | | | |
| Weight | 330 g max. | 490 g max. | | |

*1. Do not use an inverter output for the Power Supply. Inverters with an output frequency of 50/60 Hz are available, but the rise in the internal temperature of the Power Supply may result in ignition or burning.

*2. Refer to *Engineering Data (60-W, 90-W, 120-W, 180-W, and 240-W Models)* on page 7 for details.

*3. If the output voltage adjuster (V. ADJ) is turned, the voltage will increase by more than +15% of the voltage adjustment range. When adjusting the output voltage, confirm the actual output voltage from the Power Supply and be sure that the load is not damaged.

*4. To reset the protection, turn OFF the input power for three minutes or longer and then turn it back ON.

| Item | Power ratings | 120 W | 180 W | 240 W | |
|----------------------|--|---|--|------------|------------|
| Efficiency (typical) | | 80% min. | | | |
| Input | Voltage *1 | 100 to 240 VAC (85 to 264 VAC) | | | |
| | Frequency *1 | 50/60 Hz (47 to 63 Hz) | | | |
| | Current | 100-V input | 1.9 A max. | 2.9 A max. | 3.8 A max. |
| | | 200-V input | 1.1 A max. | 1.6 A max. | 2.0 A max. |
| | Power factor | 0.95 min. | | | |
| | Harmonic current emissions | Conforms to EN61000-3-2 | | | |
| | Leakage current | 100-V input | 0.5 mA max. | | |
| 200-V input | | 1.0 mA max. | | | |
| Inrush current *2 | 100-V input | 25 A max. (for a cold start at 25°C) | | | |
| | 200-V input | 50 A max. (for a cold start at 25°C) | | | |
| Output | Voltage adjustment range *3 | -10% to 15% (with V.ADJ) | | | |
| | Ripple | 2.0% (p-p) max. (at rated input/output voltage) | | | |
| | Input variation influence | 0.5% max. (at 85- to 264-VAC input, 100% load) | | | |
| | Load variation influence (rated input voltage) | 1.5% max. (with rated input, 0 to 100% load) | | | |
| | Temperature variation influence | 0.05%/°C max. | | | |
| | Startup time *2 | 1,000 ms max. (at rated input/output voltage) | | | |
| | Hold time *2 | 20 ms min. (at rated input/output voltage) | | | |
| Additional functions | Overload protection *2 | 105% to 160% of rated load current, voltage drop, automatic reset | | | |
| | Overvoltage protection *2, *4 | Yes | | | |
| | Parallel operation | No | | | |
| | Series operation | Yes for up to 2 Power Supplies (with external diode) | | | |
| Other | Operating ambient temperature | Refer to the derating curve in <i>Engineering Data (60-W, 90-W, 120-W, 180-W, and 240-W Models)</i> . (with no icing or condensation) | | | |
| | Storage temperature | -25 to 65°C | | | |
| | Operating ambient humidity | 25% to 85% (Storage humidity: 25% to 90%) | | | |
| | Dielectric strength | 3.0 kVAC for 1 min. (between all inputs and outputs; detection current: 20 mA) 2.0 kVAC for 1 min. (between all inputs and PE terminals; detection current: 20 mA) 1.0 kVAC for 1 min. (between all outputs and PE terminals; detection current: 30 mA) | | | |
| | Insulation resistance | 100 MΩ min. (between all outputs and all inputs/ PE terminals) at 500 VDC | | | |
| | Vibration resistance | 10 to 55 Hz, 0.375-mm single amplitude for 2 h each in X, Y, and Z directions 10 to 150 Hz, 0.35-mm single amplitude (5 G max.) for 80 min each in X, Y, and Z directions | | | |
| | Shock resistance | 150 m/s ² , 3 times each in ±X, ±Y, and ±Z directions | | | |
| | Output indicator | Yes (color: green) | | | |
| | EMI | Conducted Emissions | Conforms to EN61204-3 EN55011 Class A and based on FCC Class A | | |
| | | Radiated Emissions | Conforms to EN61204-3 EN55011 Class A | | |
| | EMS | Conforms to EN61204-3 high severity levels | | | |
| | Approved standards | UL: UL508 (Listing), UL60950-1 cUL: CSA C22.2 No. 107.1 cUR: CSA No. 60950-1 EN/VDE: EN50178 (= VDE0160) According to VDE0106/P100, IP20 (except terminal block) | | | |
| | SEMI | F47-0200 (200-VAC input) | | | |
| Weight | 550 g max. | 850 g max. | 1,150 g max. | | |

Note: Refer to page 2 for notes 1 to 4.

Connections

Block Diagrams

S8VE-06024-□ (60 W)

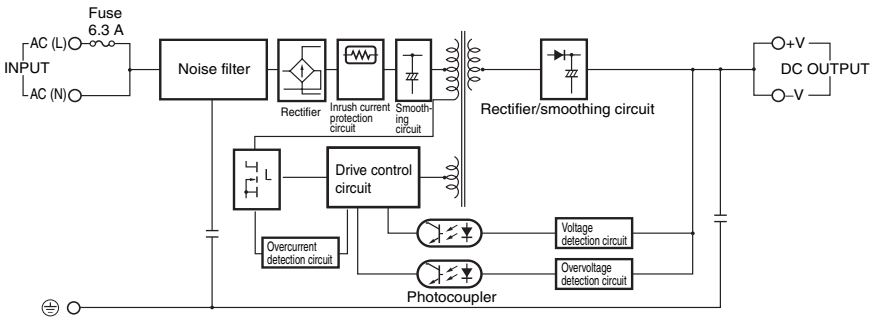

S8VE-09024-□ (90 W)

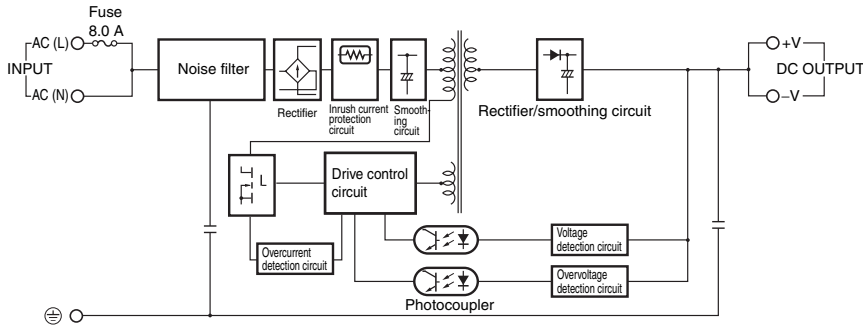

S8VE-12024-□ (120 W)

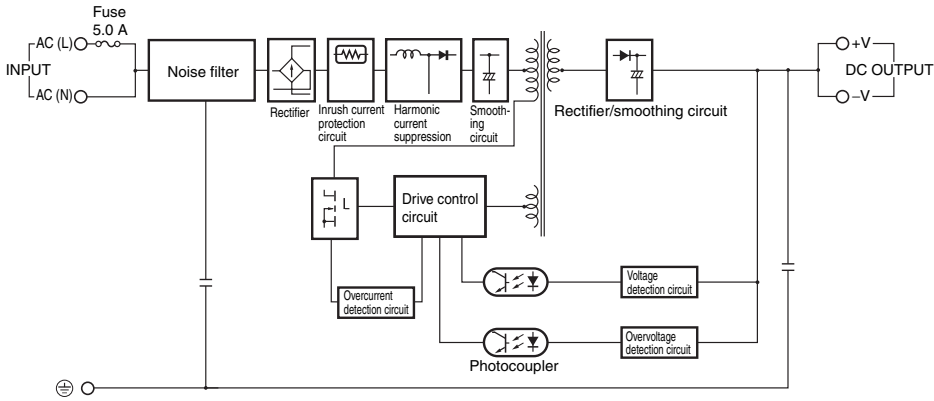

S8VE-18024-□ (180 W)

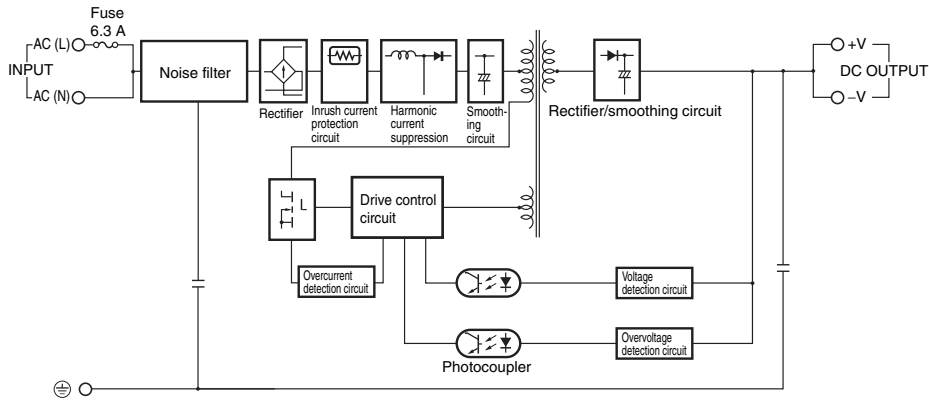

S8VE-24024-□ (240 W)

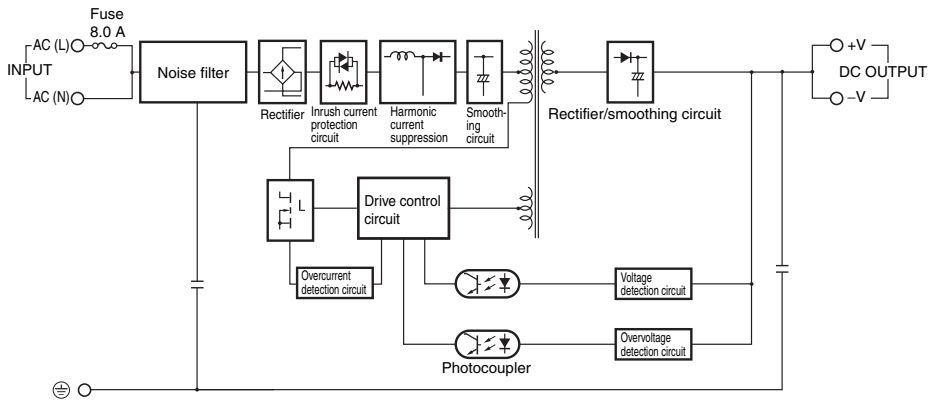

Construction and Nomenclature

Nomenclature

60-W Models

Standard Model
S8VE-06024

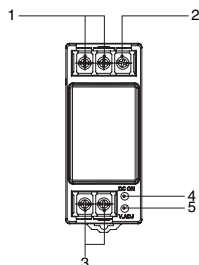

90-W/120-W Models

Standard Models
S8VE-09024/S8VE-12024

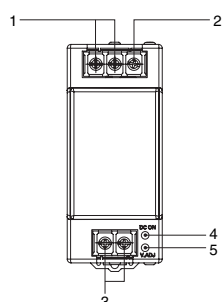

180-W Models

Standard Model
S8VE-18024

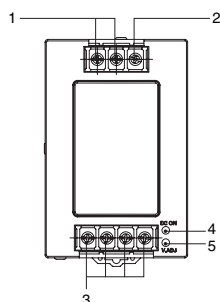

240-W Models

Standard Model
S8VE-24024

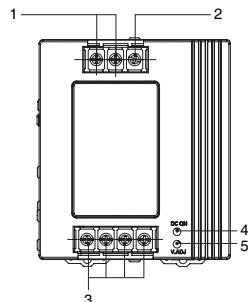

* The terminal arrangement is the same for models with screwless terminal blocks and standard models.

| No. | Name | Function |
|-----|---------------------------------|--|
| 1 | AC Input terminals (L), (N) | Connect the input lines to these terminals. *1 |
| 2 | Protective Earth terminal (PE) | Connect the ground line to this terminal. *2 |
| 3 | DC Output terminals (-V), (+V) | Connect the load lines to these terminals. |
| 4 | Output indicator (DC ON: Green) | Lights while a direct current (DC) output is ON. |
| 5 | Output voltage adjuster (V.ADJ) | Use to adjust the voltage. |

*1. The fuse is located on the (L) side. It is NOT user replaceable.

*2. This is the protective earth terminal specified in the safety standards. Always ground this terminal.

Reference Values (60-W to 240-W Models)

| Item | Value | Definition |
|--------------------|-----------------|---|
| Reliability (MTBF) | 135,000 hr min. | MTBF stands for Mean Time Between Failures, which is calculated according to the probability of accidental device failures, and indicates reliability of devices. Therefore, it does not necessarily represent the life of the Product. |
| Life expectancy | 10 yr min. | The life expectancy indicates average operating hours under the ambient temperature of 40°C and a load rate of 50%. Normally this is determined by the life expectancy of the built-in aluminum electrolytic capacitor. |

Engineering Data (60-W, 90-W, 120-W, 180-W, and 240-W Models)

Derating Curve

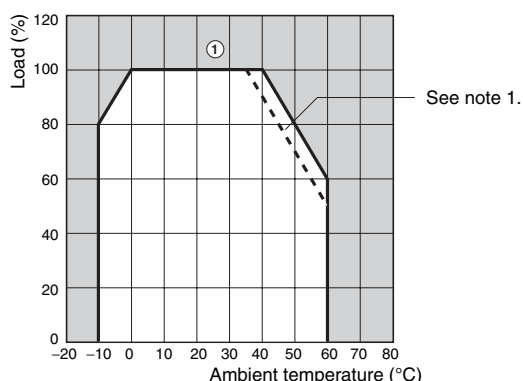

- Note: 1.** Using side mounting bracket for right-side mounting (excluding 240-W models).
- 2.** Internal parts may occasionally deteriorate or be damaged. Do not use the Power Supply in areas outside the derating curve (i.e., the area shown by shading ① in the above graph).
- 3.** If there is a derating problem, use forced air-cooling.

Mounting

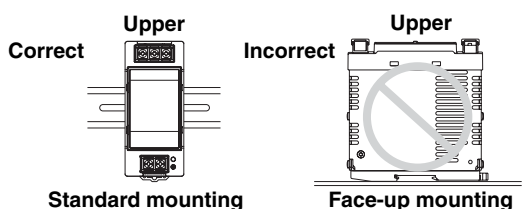

Note: Improper mounting will interfere with heat dissipation and may occasionally result in deterioration or damage of internal parts. Use the standard mounting method only.

Overload Protection

The Power Supply is provided with an overload protection function that protects the power supply from possible damage by overcurrent. When the output current rises above 105% min. of the rated current, the protection function is triggered, decreasing the output voltage. When the output current falls within the rated range, the overload protection function is automatically cleared.

60-W/90-W Models

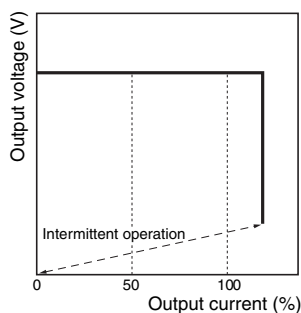

120-W/180-W/240-W Models

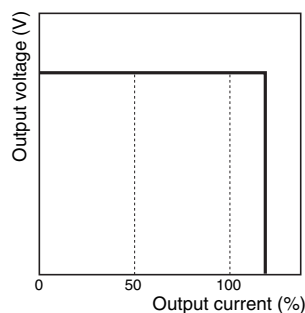

The values shown in the above diagrams are for reference only.

- Note: 1.** Internal parts may occasionally deteriorate or be damaged if a short-circuited or overcurrent state continues during operation.
- 2.** Internal parts may possibly deteriorate or be damaged if the Power Supply is used for applications with frequent inrush current or overloading at the load end. Do not use the Power Supply for such applications.

Overvoltage Protection

Consider the possibility of an overvoltage and design the system so that the load will not be subjected to an excessive voltage even if the feedback circuit in the Power Supply fails. If an excessive voltage that is approximately 130% of the rated voltage or more is output, the output voltage is shut OFF. Reset the input power by turning it OFF for at least three minutes and then turning it back ON again.

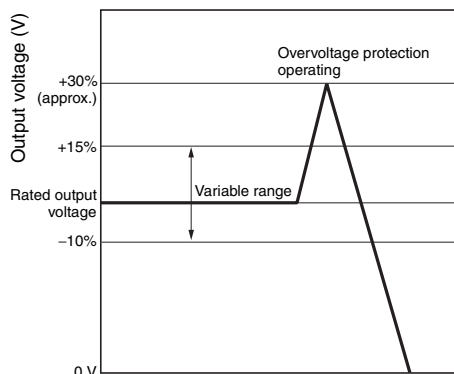

The values shown in the above diagram is for reference only.

Note: Do not turn ON the power again until the cause of the overvoltage has been removed.

Inrush Current, Startup Time, Output Hold Time

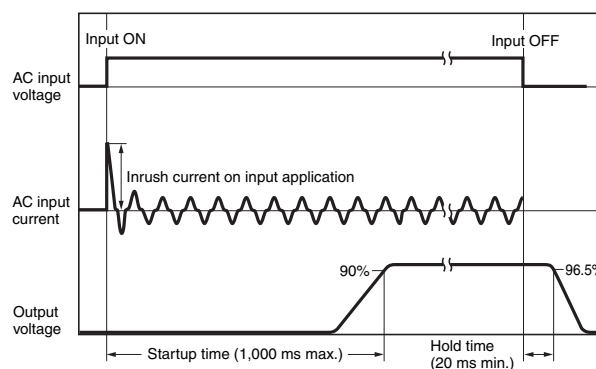

Dimensions

Power Supplies with Screw Terminal Blocks

Note: All units are in millimeters unless otherwise indicated.

S8VE-06024 (60 W)

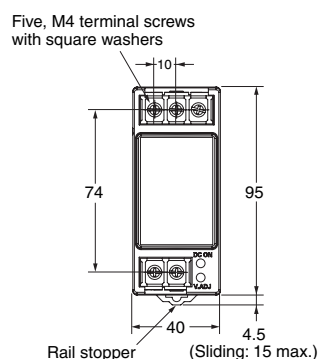
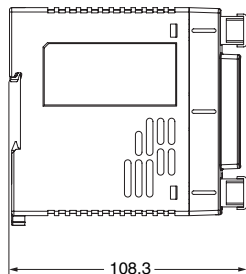

S8VE-09024 (90 W) S8VE-12024 (120 W)

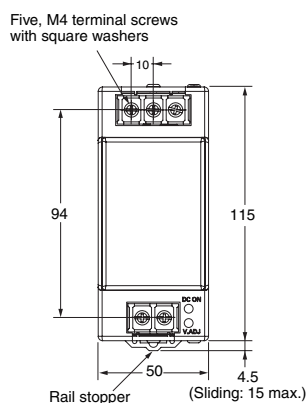
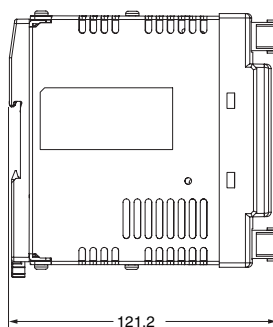

Note: The illustration shows the S8VE-12024 model.

S8VE-18024 (180 W)

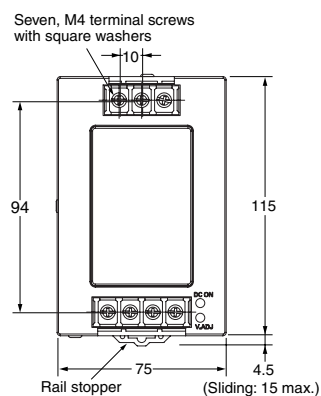
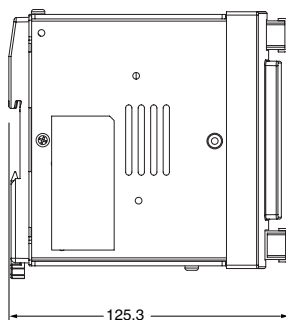

S8VE-24024 (240 W)

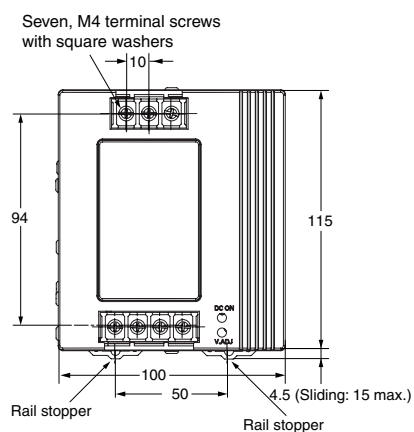
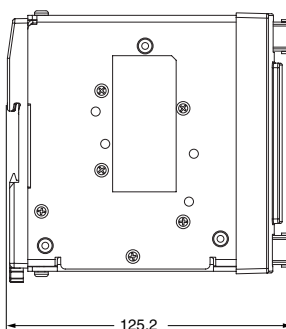

Power Supplies with Screwless Terminal Blocks

S8VE-06024-F (60 W)

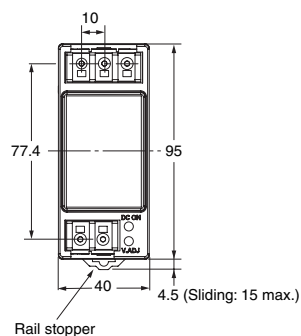
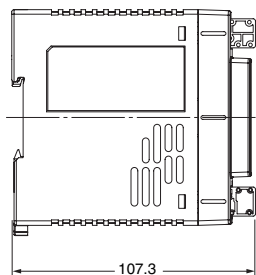

S8VE-09024-F (90 W) S8VE-12024-F (120 W)

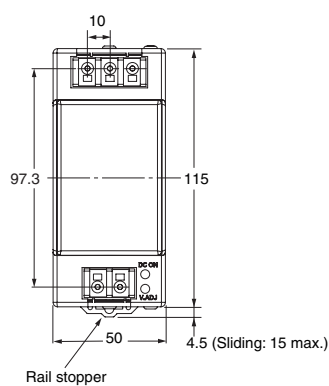
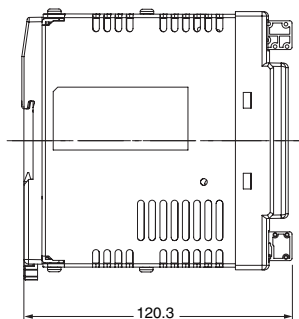

Note: The illustration shows the S8VE-12024-F model.

S8VE-18024-F (180 W)

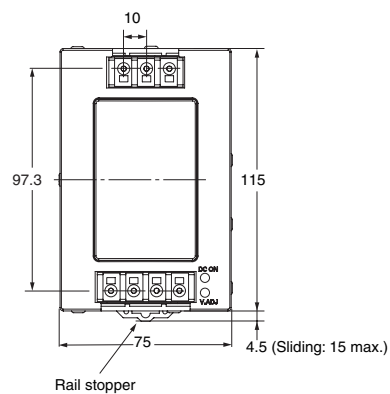
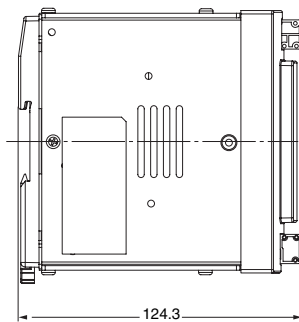

S8VE-24024-F (240 W)

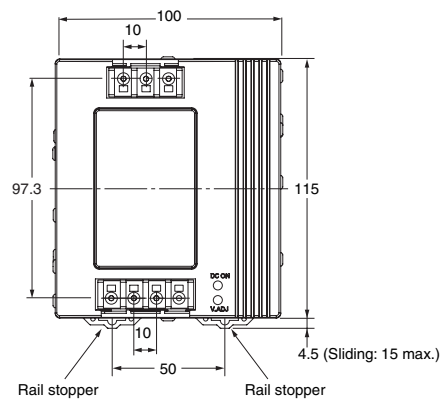
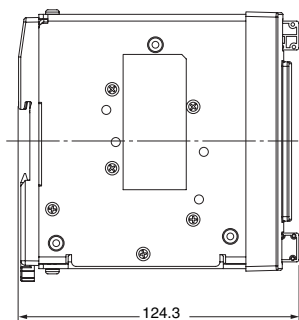

DIN Rail (Order Separately)

Note: All units are in millimeters unless otherwise indicated.

Mounting Rail (Material: Aluminum)

PFP-100N

PFP-50N

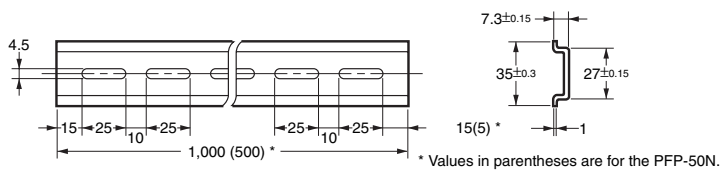
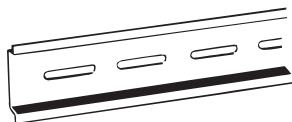

Mounting Rail (Material: Aluminum)

PFP-100N2

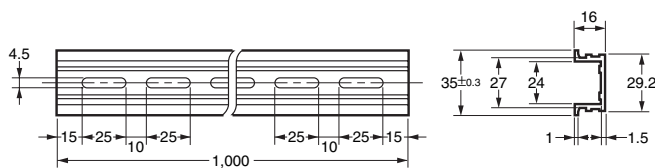
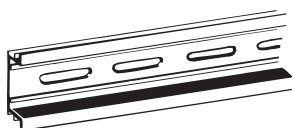

End Plate

PFP-M

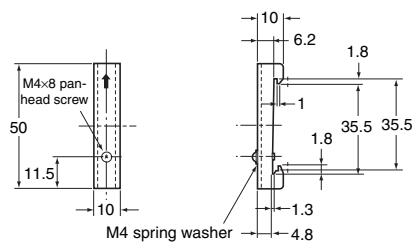
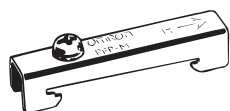

Note: If there is a possibility that the Unit will be subject to vibration or shock, use a steel DIN Rail. Otherwise, metallic filings may result from aluminum abrasion.

Mounting Brackets

| Name | Model |
|---|-------------------|
| Side-mounting Bracket (for 60-, 90-, and 120-W models) | S82Y-VS10S |
| Side-mounting Bracket (for 180-W models) | S82Y-VS15S |
| Side-mounting Bracket (for 240-W models) | S82Y-VS20S |
| Front-mounting Bracket (for 60-, 90-, 120-, 180-, and 240-W models) * | S82Y-VS10F |

Note: Two required to mount a 240-W model.

| Type | Model | Dimensions | Appearance |
|--|-------------------|------------|--|
| Side-mounting Bracket (For 60-, 90-, 120-W models) | S82Y-VS10S | | <p>Left-side mounting</p> <p>*Right-side mounting also possible.</p> |
| Side-mounting Bracket (For 180-W models) | S82Y-VS15S | | <p>Left-side mounting</p> <p>*Right-side mounting also possible.</p> |
| Side-mounting Bracket (For 240-W models) | S82Y-VS20S | | <p>Left-side mounting</p> <p>*Right-side mounting also possible.</p> |
| Front-mounting Bracket (For 60-, 90-, 120-, 180-, and 240-W models) | S82Y-VS10F | | <p>(For 60-, 90-, 120-, 180-W types) (For 240-W type)</p> <p>*Use two S82Y-VS10F brackets for the 240-W type.</p> |

Safety Precautions

Refer to Safety Precautions for All Power Supplies.

CAUTION

Minor electric shock, fire, or Product failure may occasionally occur. Do not disassemble, modify, or repair the Product or touch the interior of the Product.



Minor burns may occasionally occur. Do not touch the Product while power is being supplied or immediately after power is turned OFF.



Fire may occasionally occur. Tighten terminal screws to the specified torque (60-, 90-, 120-, 180-, and 240- models: 1.08 N·m).



Minor injury due to electric shock may occasionally occur. Do not touch the terminals while power is being supplied. Always close the terminal cover after wiring.



Minor electric shock, fire, or Product failure may occasionally occur. Do not allow any pieces of metal or conductors or any clippings or cuttings resulting from installation work to enter the Product.



Precautions for Safe Use

Mounting

- Take adequate measures to ensure proper heat dissipation to increase the long-term reliability of the Product. Be sure to allow convection in the atmosphere around devices when mounting. Do not use in locations where the ambient temperature exceeds the range of the derating curve.
- When cutting out holes for mounting, make sure that cuttings do not enter the interior of the Products.

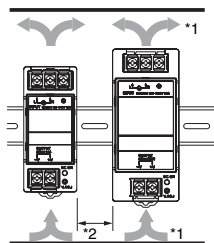

- *1. Convection of air
*2. 20 mm min.

60-W, 90-W, 120-W, 180-W, and 240-W Models

- Improper mounting will interfere with heat dissipation and may occasionally result in deterioration or damage of internal parts. Use the standard mounting method only.
- The internal parts may occasionally deteriorate and be broken due to adverse heat radiation. Do not loosen the screw on the side face of the main body.

Wiring

- Connect the ground completely. A protective earthing terminal stipulated in safety standards is used. Electric shock or malfunction may occur if the ground is not connected completely.
- Minor fire may possibly occur. Ensure that input and output terminals are wired correctly.
- Do not apply more than 100-N force to the terminal block when tightening it.
- Be sure to remove the sheet covering the Product for machining before power-ON so that it does not interfere with heat dissipation.
- When wiring a screwless terminal block, do not insert more than one wire into a single terminal.

- When using a screwless terminal block, connect or disconnect the I/O wire to each terminal while inserting an appropriate tool, such as a flat-blade screwdriver, into the tool insertion hole. Make sure that the wire is securely connected to the terminal after wiring. Do not insert wires into the tool insertion holes.

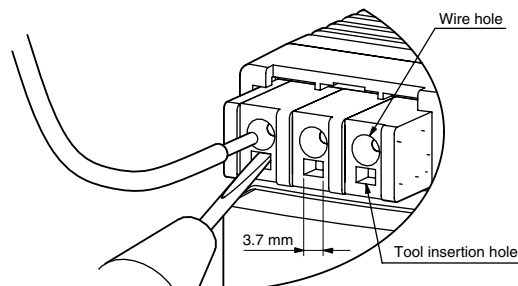

- Use the following material for the wires to be connected to the S8VE to prevent smoking or ignition caused by abnormal loads.

60-W, 90-W, 120-W, 180-W, and 240-W Models

| Model | Recommended wire size | |
|--------------|---|---|
| | Input terminals | Output terminals |
| S8VE-06024-□ | AWG14 to 20 (Cross section: 0.517 to 2.081 mm ²) | AWG14 to 20 (Cross section: 0.517 to 2.081 mm ²) |
| S8VE-09024-□ | | AWG14 to 18 (Cross section: 0.823 to 2.081 mm ²) |
| S8VE-12024-□ | | AWG14 to 16 (Cross section: 1.309 to 2.081 mm ²) |
| S8VE-18024-□ | | AWG14 (Cross section: 2.081 mm ²) |
| S8VE-24024-□ | | AWG14 (Cross section: 2.081 mm ²) |

- Strip I/O wires for 11 mm when using a screwless terminal block.

Installation Environment

- Do not use the Power Supply in locations subject to shocks or vibrations. In particular, install the Power Supply as far away as possible from contactors or other devices that are a vibration source.
- Install the Power Supply well away from any sources of strong, high-frequency noise and surge.

Operating Life

- The life of a Power Supply is determined by the life of the electrolytic capacitors used inside. Here, Arrhenius Law applies, i.e., the life will be cut in half for each rise of 10°C or the life will be doubled for each drop of 10°C. The life of the Power Supply can thus be increased by reducing its internal temperature.

Ambient Operating and Storage Environments

- Store the Power Supply at a temperature of -25 to 65°C and a humidity of 25% to 90%.
- Do not use the Power Supply in areas outside the derating curve otherwise, internal parts may occasionally deteriorate or be damaged.
- Use the Power Supply at a humidity of 25% to 85%.
- Do not use the Power Supply in locations subject to direct sunlight.
- Do not use locations where liquids, foreign matter, or corrosive gases may enter the interior of Products.

Output Voltage Adjuster (V.ADJ)

- The output voltage adjuster (V.ADJ) may possibly be damaged if it is turned with unnecessary force. Do not turn the adjuster with excessive force.
- After completing output voltage adjustment, be sure that the output capacity or output current does not exceed the rated output capacity or rated output current.

DIN Rail Mounting

To mount the Block on a DIN Rail, hook portion (A) of the Block onto the rail and press the Block in direction (B).

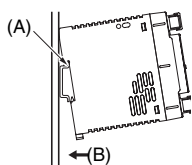

To dismount the Block, pull down portion (C) with a flat-blade screwdriver and pull out the Block.

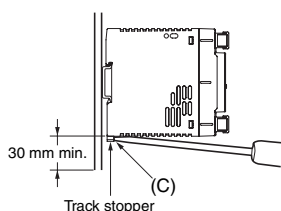

Series Operation

Two power supplies can be connected in series.

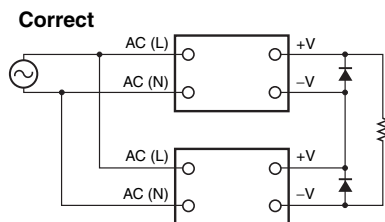

Note: 1. The diode is connected as shown in the figure. If the load is short-circuited, a reverse voltage will be generated inside the Power Supply. If this occurs the Power Supply may possibly deteriorate or be damaged. Always connect a diode as shown in the figure. Select a diode having the following ratings.

| Type | Schottky Barrier diode |
|----------------------------|---|
| Dielectric strength (VRRM) | Twice the rated output voltage or above |
| Forward current (IF) | Twice the rated output current or above |

2. Although Products having different specifications can be connected in series, the current flowing through the load must not exceed the smaller rated output current.

Parallel Operation

The Product is not designed for parallel operation.

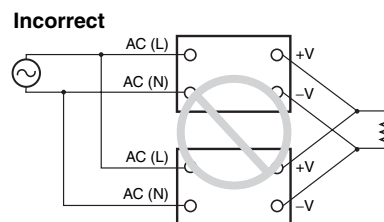

In Case There Is No Output Voltage

The possible cause for no output voltage may be that the overcurrent or overvoltage protection has operated. The internal protection may operate if a large amount of surge voltage such as a lightning surge occurs while turning ON the power supply.

In case there is no output voltage, please check the following points before contacting us:

- Checking overload protected status:
Check whether the load is in overload status or is short-circuited. Remove wires to load when checking.
- Checking overvoltage or internal protection:
Turn the power supply OFF once, and leave it OFF for at least 3 minutes. Then turn it ON again to see if this clears the condition.

Buzzing Noise When the Input Is Turned ON (120-W, 180-W, and 240-W Models)

A harmonic current suppression circuit is built into the Power Supply. This circuit can create noise when the input is turned ON, but it will last only until the internal circuits stabilize and does not indicate any problem in the Product.

ALL DIMENSIONS SHOWN ARE IN MILLIMETERS.

To convert millimeters into inches, multiply by 0.03937. To convert grams into ounces, multiply by 0.03527.

In the interest of product improvement, specifications are subject to change without notice.