

G5LA

PCB Power Relay

A Cubic, Single-pole 10A Power Relay

- Economical cube relay with universal terminal footprint
- Conforms to VDE0435
- UL recognized/CSA certified.
- High switching power: 10A @ 250VAC
- Withstands impulse of up to 4,500V
- Coil power consumption: 360mW
- UL Class F coil insulation type also available
- Tracking resistance: CTI>250

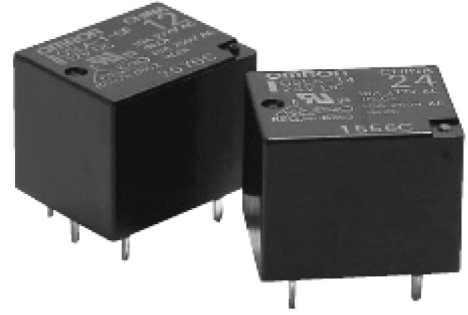

RoHS Compliant

Model Number Legend

G5LA-□□□-□-□
1 2 3 4 5

- | | |
|--|--|
| <p>1. Number of poles
1: 1-pole</p> <p>2. Contact Form
None: SPDT (1c)
A: SPST-NO (1a)</p> <p>3. Enclosure rating
None: Flux protection
4: Fully sealed</p> | <p>4. Classification
None: Standard
E: High capacity (NC side)</p> <p>5. UL Insulation System
None: Standard
CF: Class F</p> |
|--|--|

Application Examples

- Home appliance
- OA equipments
- Vending machines, etc.

G
5
L
A

Ordering Information

Classification	Terminal Shape	Contact form	Enclosure rating	Model	Rated coil voltage	Minimum packing unit
Standard	PCB terminals	SPST-NO (1a)	Flux protection	G5LA-1A(-CF)	5VDC 9VDC 12VDC 24VDC 48VDC	100 pcs/tray
			Fully-sealed	G5LA-1A4(-CF)		
		SPDT (1c)	Flux protection	G5LA-1(-CF)		
			Fully-sealed	G5LA-14(-CF)		
High-capacity		SPDT (1c)	Flux protection	G5LA-1-E(-CF)		
			Fully-sealed	G5LA-14-E(-CF)		

Note. When ordering, add the rated coil voltage to the model number.

Example: G5LA-1 DC 12 Rated coil voltage

Ratings

Coil

Rated voltage (VDC)	Rated current (mA)	Coil resistance (Ω)	Must operate voltage (V)	Must release voltage (V)	Max. voltage (V)	Power consumption (mW)
			% of rated voltage			
5	72	69.4	75% max.	10% min.	130% (at 85°C) 170% (at 23°C)	Approx. 360
9	40	225				
12	30	400				
24	15	1600				
48	10	4800				Approx. 480

Note 1. The rated current and coil resistance are measured at a coil temperature of 23°C with tolerances of ±10%.

2. Please avoid ultrasonic cleaning this relay.

●Contacts

Item		Standard model	High-capacity (-E) model
Contact material		Ag-alloy (Cd free)	
Load		Resistive load (cosφ=1)	
Rated load	NO	10A at 250VAC 10A at 24VDC	
	NO/NC	5A/5A at 125VAC 5A/5A at 24VDC	5A/5A at 250VAC 5A/5A at 24VDC
Rate carry current		10A (NO), 5A (NC)	10A
Max. switching voltage		250VAC, 24VDC	
Max. switching current		10A (NO), 5A (NC)	10A
Max. switching power	NO	AC2,500VA, DC240W	
	NO/NC	AC625VA, DC120W	AC1,250VAC, DC120W
Failure rate (reference value)		100mA at 5VDC	

Note. P level: $\lambda_{60} = 0.1 \times 10^{-5}/\text{operation}$

■Characteristics

Contact resistance	100 mΩ max.
Operate time	10 ms max.
Release time	5 ms max.
Max. switching frequency	Mechanical: 18,000 operations/hr Electrical: 1,800 operations/hr (under rated load)
Insulation resistance	1,000 mΩ min. (at 500 VDC)
Dielectric strength	2,000 VAC, 1mA 50/60Hz for 1 min between coil and contacts 750 VAC 1mA 50/60Hz for 1 min between contacts of same polarity
Vibration resistance	Destruction: 10 to 55Hz, 1.5mm double amplitude Malfunction: 10 to 55Hz, 1.5mm double amplitude
Shock resistance	Destruction: 1,000m/s ² (approx. 100G) Malfunction: 100 m/s ² (approx. 10G)
Endurance	Mechanical: 10,000,000 operations min. Electrical: Approx. 100,000 operations
Ambient operating temperature	-40° to 85° (with no icing or condensation)
Ambient operating humidity	5% to 85%
Weight	Approx. 7.5g

Note. Values in the above table are the initial values.

Engineering Data

Maximum switching capacity (NO)

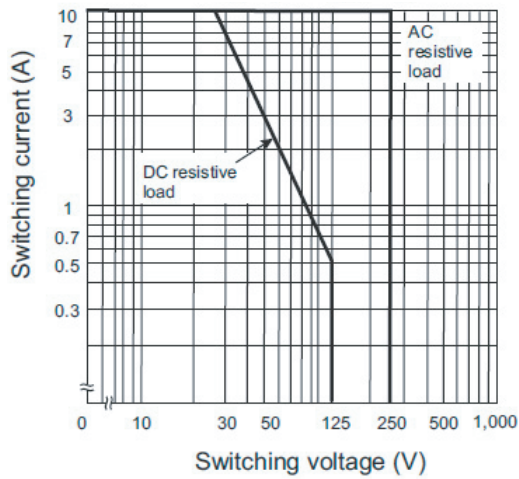

Durability (NO) (Average value)

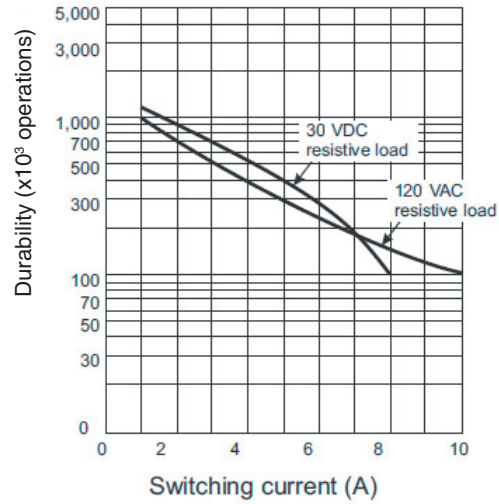

Ambient Temperature vs. Maximum Coil Voltage

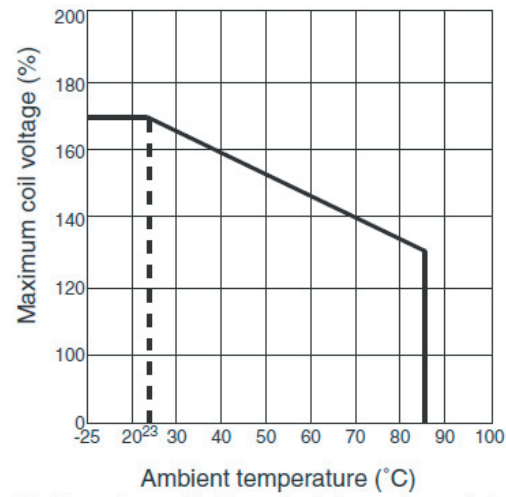

Note. The 120 VAC resistive load service life curve also applies for 250 VAC resistive load.

Note. The maximum coil voltage refers to the maximum value in a varying range of operating power voltage not a continuous voltage.

■Dimensions

Note. All units are in millimeters unless otherwise indicated.

G5LA-1(-CF)
 G5LA-14(-CF)
 G5LA-1-E(-CF)
 G5LA-14-E(-CF)

PCB Mounting Holes
 (Bottom View)
 Tolerance: ± 0.1 mm
 Unless specified

Terminal
 Arrangement/Internal
 Connections (Bottom View)

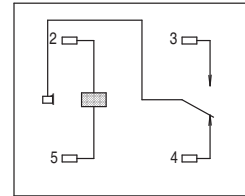
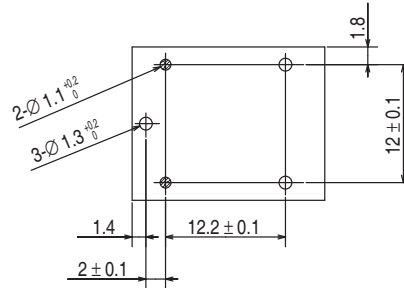
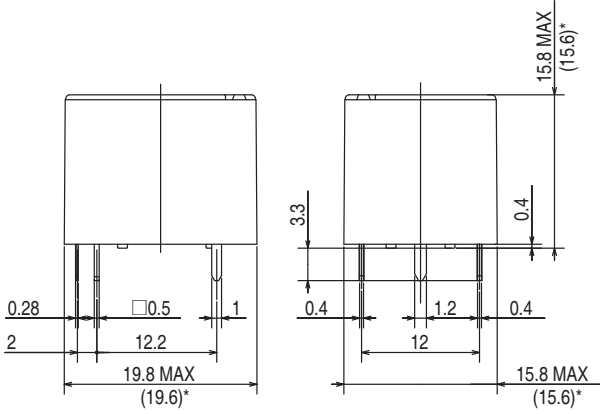

G
5
L
A

G5LA-1A(-CF)
 G5LA-1A4(-CF)

PCB Mounting Holes
 (Bottom View)
 Tolerance: ± 0.1 mm
 Unless specified

Terminal
 Arrangement/Internal
 Connections (Bottom View)

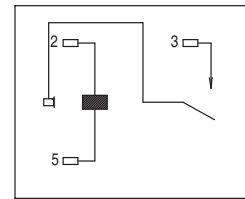
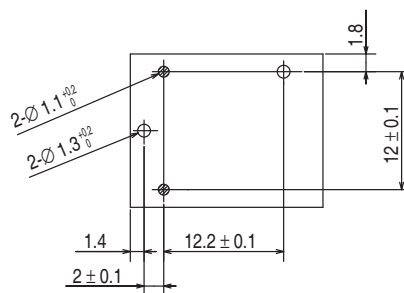
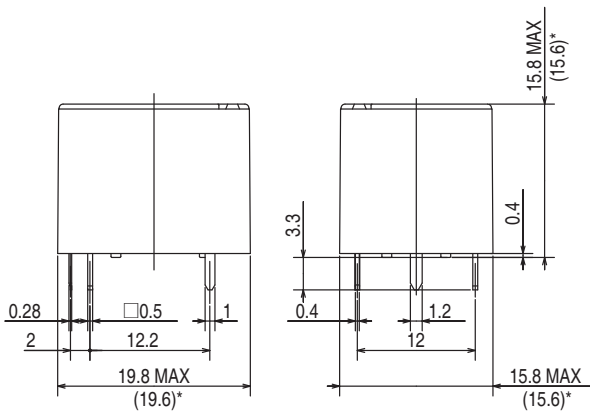

■Approved Standards

●UL Recognized (File No. E41643)

Model	Contact form	Coil ratings	Contact ratings	Number of test operations
G5LA	SPDT-NO (1a) SPST-NO (1a)	5 to 48 VDC	10 A, 277 VAC, general use, 40°C	100,000
			10 A, 30 VDC, resistive, 40°C	50,000
			1/2 HP, 125-250VAC, 40°C	1,000
			10 A, 277 VAC, general use, 85°C (-CF type only)	50,000
			200 W Tungsten, 125 VAC, 40°C	100,000
	SPDT-NC (1b)		10 A, 125 VAC, resistive, 40°C	6,000
			10 A, 277 VAC, general use, 40°C (-E type only)	100,000
			10A, 24 VDC, resistive, 40°C (-E type only)	

●CSA Certified (File No. LR31928)

Model	Contact form	Coil ratings	Contact ratings	Number of test operations
G5LA	SPDT-NO (1a) SPST-NO (1a)	5 to 48 VDC	10 A, 277 VAC, general use, 40°C	6,000
			10 A, 24 VDC, resistive, 40°C	
			1/2 HP, 125-250VAC, 40°C	1,000
			10 A, 277 VAC, general use, 85°C (-CF type only)	6,000
	SPDT-NC (1b)		10 A, 125 VAC, resistive, 40°C	

●VDE Certified (Approval No. 40017051)

Model	Contact form	Coil ratings	Contact ratings	Number of test operations
G5LA	SPDT-NO (1a) SPST-NO (1a)	5, 9, 12, 24, 48 VDC	10 A, 250 VAC, resistive, 85°C (flux protection)	50,000
			10 A, 250 VAC, resistive, 85°C (fully sealed)	10,000
			12 A, 250 VAC, resistive, 85°C	
	SPDT (1c)		5 A, 250 VAC, resistive, 85°C (flux protection)	50,000
			5 A, 250 VAC, resistive, 85°C (fully sealed)	10,000

• Application examples provided in this document are for reference only. In actual applications, confirm equipment functions and safety before using the product.
 • Consult your OMRON representative before using the product under conditions which are not described in the manual or applying the product to nuclear control systems, railroad systems, aviation systems, vehicles, combustion systems, medical equipment, amusement machines, safety equipment, and other systems or equipment that may have a serious influence on lives and property if used improperly. Make sure that the ratings and performance characteristics of the product provide a margin of safety for the system or equipment, and be sure to provide the system or equipment with double safety mechanisms.

Note: Do not use this document to operate the Unit.

OMRON Corporation

ELECTRONIC AND MECHANICAL COMPONENTS COMPANY

Contact: www.omron.com/ecb

Cat. No. J184-E1-02
0113(1012)(O)