

LED Displacement Sensor

Z4W-V

Low-cost Displacement Sensor with 10-micron Resolution with Red LED

- Measurement point: 25 mm;
measurement range: ± 4 mm.
- Easy adjustment, range/stable light indicators.
- Easy-to-use built-in Amp.
- High-speed response: 5 ms.
- Visible beam spot.
- Enclosure rating: IP66.



Ordering Information

Sensing distance	Resolution	Model
25 \pm 4 mm	10 μ m	Z4W-V25R 5M

Specifications

■ Ratings

Measurement range	±4 mm
Measurement point	25±1 mm
Light source	Red LED
Spot diameter	2-mm dia. (at measurement point)
Resolution	10 microns (see Note. 1)
Linearity	±3% FS (See Note. 2)
Response time	5 ms (In case of white alumina ceramic. Linearity change according to object.)
Temperature characteristics	±0.3% FS/°C
Warming up time	3 min (within 1% of stable value)
Indicators	Stability: Stable range: Lit green Operating range: Not lit Dark: Lit red Range: In range: Green Out of range: Red
Outputs	Analog output: 4 to 20 mA/±4 mm Load impedance: 300Ω max. DARK output: NPN open collector 50 mA max., 30 VDC Residual voltage: 1 V max.
External light	3,000 In (incandescent light)

■ Characteristics

Power supply voltage	12 to 24 VDC±10%: ripple (p-p) 10% max.
Current consumption	80 mA max.
Vibration resistance	Destruction: 10 to 55 Hz (1.5-mm double amplitude) for 2 sweeps of 15 min each in X, Y, and Z directions
Shock resistance	Destruction: 500 m/s ² for 3 times each in X, Y, and Z directions
Ambient temperature	Operating: -10° to 55°C (with no icing)
Ambient humidity	35% to 85% (with no icing)
Degree of protection	IP66
Weight	150 g (with 5-m cable); 50 g (without cable)
Attachments	Mounting bracket, mounting screws, resistor (250Ω, 0.5 W)

Note: 1. Resolution

The resolution is the peak-to-peak displacement conversion value of the analog output.
(Conditions: white alumina ceramic at the measurement point)



2. Response Time

The delays are the 10% to 90% rising and falling times of the analog output in response to a sudden change in the displacement.

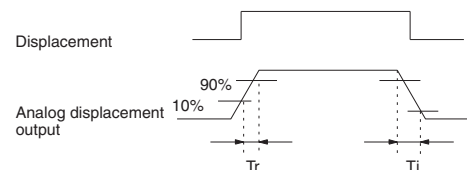

Engineering Data (Reference Value)

■ Linearity Characteristics vs. Objects

Linearity characteristic curves are obtained by detecting an object at different positions within the measurement range and plotting the analog output error resulting from each operation.

The LED Displacement Sensor cannot detect an object accurately if the reflection ratio of the object is extremely small (a black object) or extremely large (an object with a glossy surface).

Inclined Object (Typical Example)

Angle: 0°

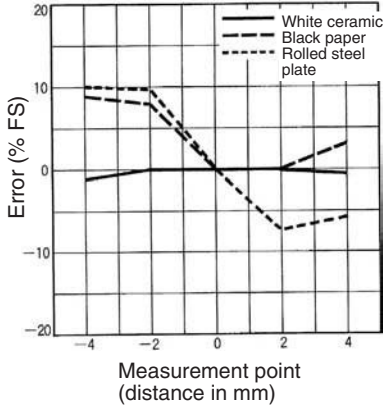

Angle: -15°

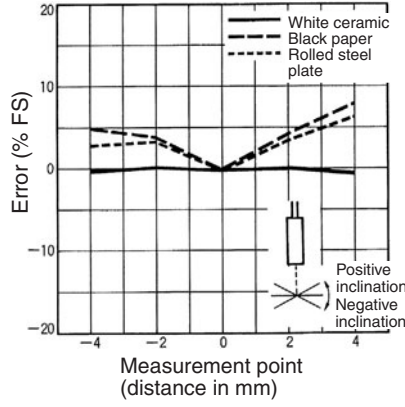

Angle: +15°

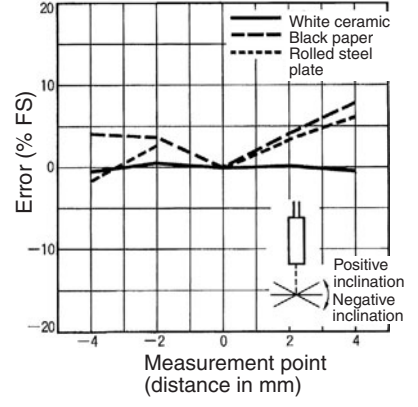

Angle: -30°

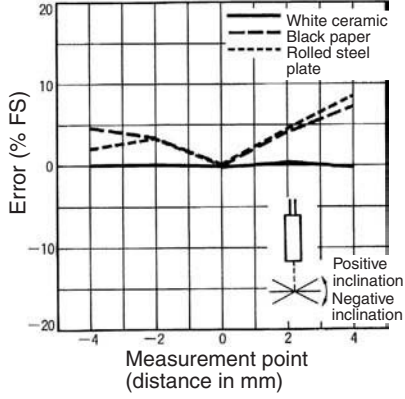

Angle: +30°

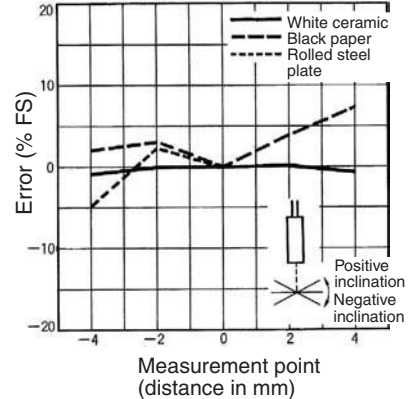

Obliquely Positioned Object (Typical Example)

Angle: -15°

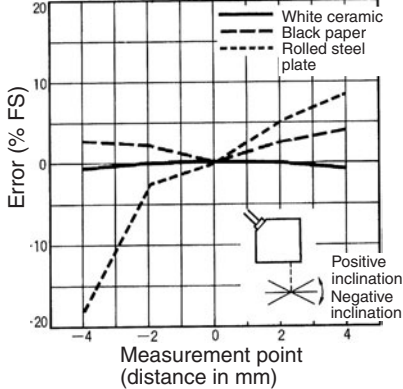

Angle: +15°

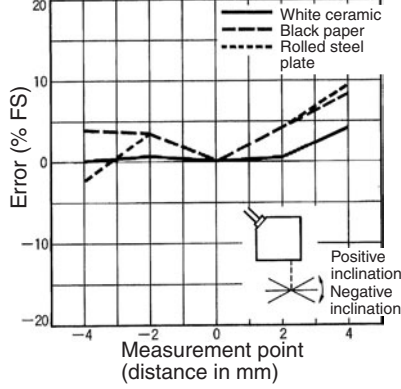

Angle: -30°

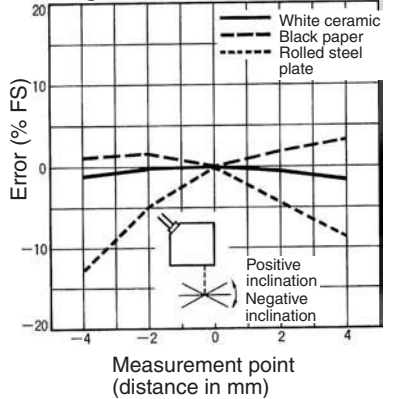

Angle: +30°

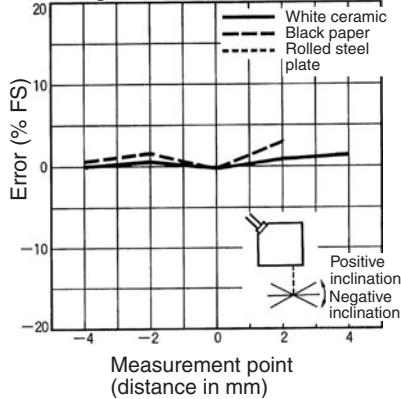

Note: The LED Displacement Sensor cannot detect an object accurately if the object is positioned at an angle oblique to the sensor position. If the oblique angle is large, detection is not possible because of insufficient reflection of light. This must be taken into consideration when installing the sensor.

■ Sensing Various Objects

Offset Error vs. Object Material

When detecting a variety of objects successively, refer to the offset error graph below. The graph illustrates the change in sensor output characteristics when black paper is compared to white paper. To reduce the offset error value, install the Sensor so that objects are detected at or as close as possible to the measurement point.

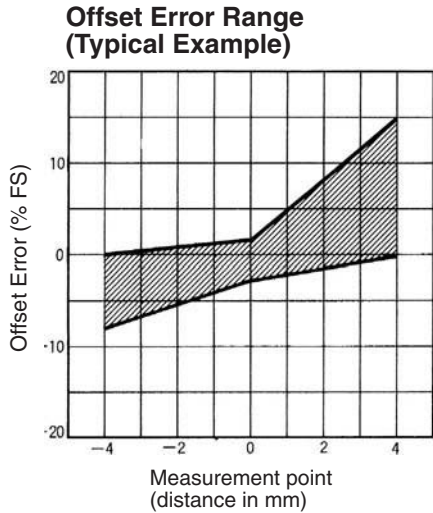

■ Angle Characteristics

The angle characteristics were obtained by detecting an object with different angles of inclination at the measurement point and plotting the analog output error resulting from each operation.

The LED Displacement Sensor is designed to detect the front of an object facing the sensor. Error occurs when the object is positioned at an oblique angle to the sensor.

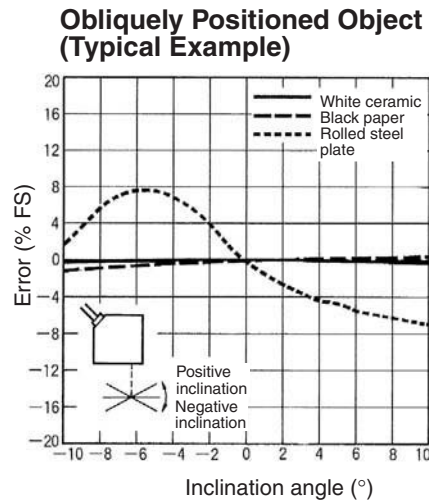
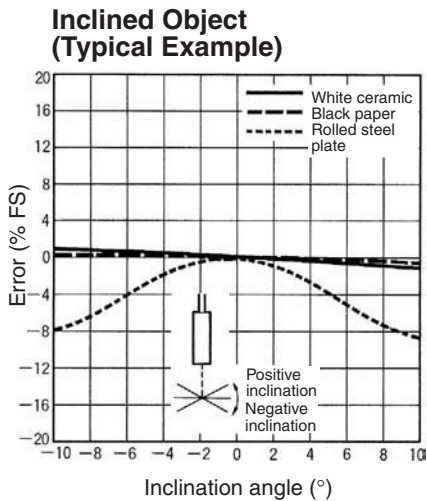

Nomenclature

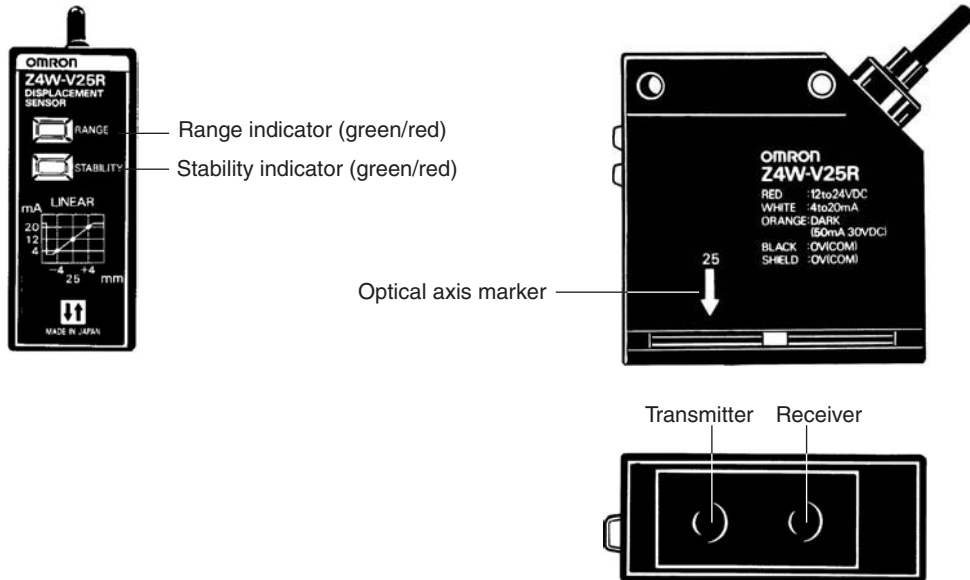

Operation

■ Connections/Output Circuits

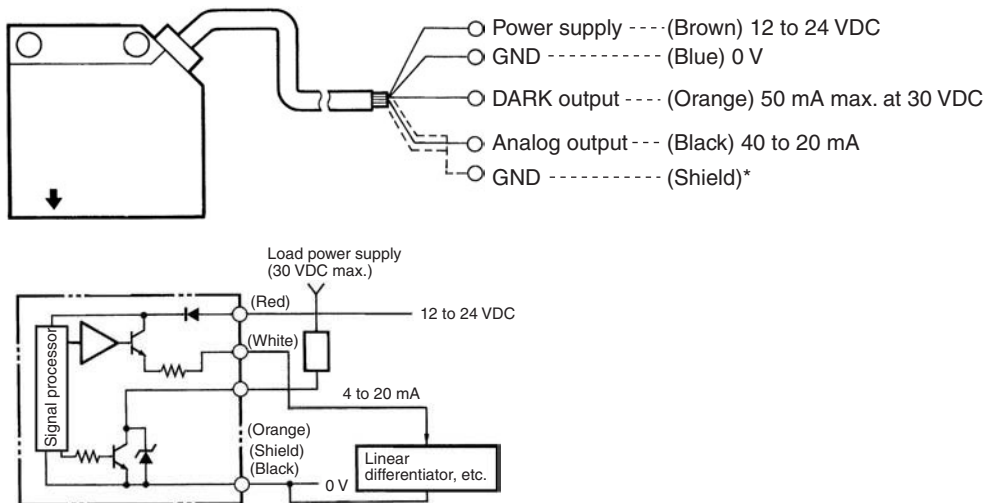

Note: *The two ground terminals (black and shield) are internally connected. However, the black ground must be used with the red terminal for the power supply and the shield ground must be used with the white terminal for the analog output.

■ Functions

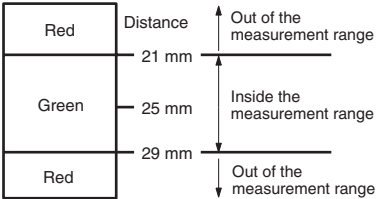
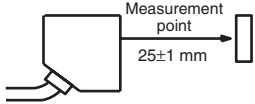
Classification	Functions	Remarks
Range indicator	<p>The green indicator is lit when the object is within the measurement range. The red indicator is lit when the object is not within the measurement range.</p> 	When the intensity of the light input is insufficient (DARK output is ON and the red stability indicator is lit), the range indicator all remain OFF even if the object is within the measurement range.
Stability indicator	<p>These indicators indicate the intensity of the light input. The object in the measurement range is detected when the green indicator is lit or OFF. The red indicator is lit when there is no object in the measurement range or the intensity of light input is insufficient.</p> <p>If this green indicator is lit when there is an object in the measurement range, the light source control circuit and light input sensitivity control circuit of the Sensor operate. Even if the green indicator is OFF, the Sensor works as long as the internal light source control circuit and the light input sensitivity circuit are within the operating range. In this case the red indicator is also OFF.</p> <p>When the Sensor is active for a long duration, the green indicator may turn OFF. This does not mean that the Sensor has malfunctioned.</p>	---
DARK output	<p>The orange indicator (DARK output) is ON when there is no object in the measurement range or when the input light intensity is insufficient. The red stability indicator is also lit when DARK output is ON.</p> <p>The Sensor has an open collector output of 50 mA at 30 VDC max.</p>	---
Analog output	<p>An analog signal is output from the output line (white) according to the sensing distance.</p> <p>Output: 4 to 20 mA/21 to 29 mm (± 4 mm) Load impedance: 300 Ω max. The output range lies between 20.5 and 26 mA when DARK output is ON.</p> 	---

■ Operations

Basic Operation of the Z4W-V25R

Mounting

Install the Sensor so that the optical axis of the Sensor and the surface of the object meet at right angles (i.e., the panel that incorporates the light source is parallel with the object). For accurate results, it is recommended that the sensing distance is set to the measurement point (25 mm).

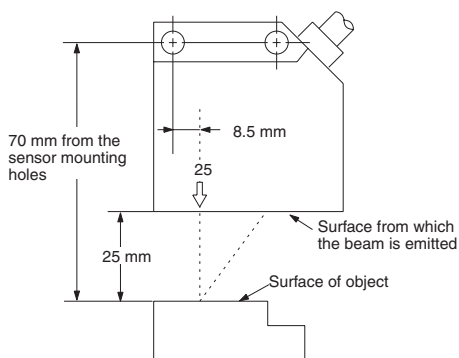

Note: Do not tighten the mounting screws for the moment as the optical axis must be adjusted.

Wiring

Connect the Sensor to the controlling device using a sensor cable. Do not switch power ON during wiring. Refer to the instructions on the Sensor and the connection diagram (page 5) before connecting the sensor to the controlling device.

Conversion to Voltage Output Model (1 to 5 V)

The Z4W-V25R has a current output of 4 to 20 mA. With the resistor provided (250 Ω), a voltage output of 1 to 5 V can be obtained. Refer to the figure below for connection.

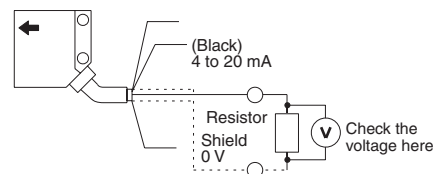

Although a resistor is included, any resistor may be used provided the resistance is 300 Ω or less.

Axis Adjustment

When the Sensor power is switched ON, the red transmitter indicator is lit. Move the Sensor so that the red beam (see the figure below) focuses on the object. The entire light beam should be focused on the object or an error will result.

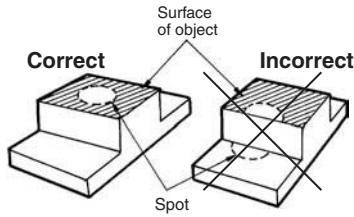

After the optical axis has been adjusted, tighten the mounting screws firmly.

Connecting a Z4W-DD1C Linear Sensor Controller

To discriminate among objects according to size, use the Z4W-V25R LED Displacement Sensor with a Z4W-DD1C Linear Sensor Controller.

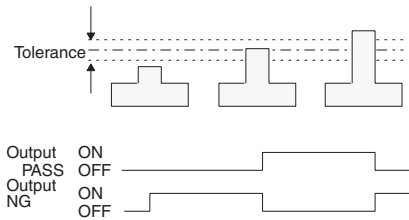

The following equipment is required:

- Z4W-V25R LED Displacement Sensor
- Z4W-DD1C Linear Sensor Controller
- Synchronization Sensor (E3X Fiber Photoelectric Sensor or E3C-VM Miniature Head Photoelectric Sensor is recommended)
- An object of standard dimensions
- An object of threshold dimensions
- Tools

Mounting

Mount as described on page 6.

When installing a Synchronization Sensor, refer to the instruction manual and read the precautions for the model. It is important to install the Synchronization Sensor so that the LED Displacement Sensor can detect the object at the measurement position. Do not tighten the mounting screws for the moment since the optical axis must be adjusted.

The Z4W-DD1C Linear Sensor Controller can be mounted on a wall and secured with screws, or mounted to DIN rail.

Wiring

Make sure that the Linear Sensor Controller, the LED Displacement Sensor, and the Synchronization Sensor are wired correctly before turning on the Linear Sensor Controller power (power is supplied to the LED Displacement Sensor and the Linear Sensor Controller by the Linear Sensor Controller). To avoid trouble, leave the output terminals (No. 4, 5, 6) of the Linear Sensor Controller open for the moment.

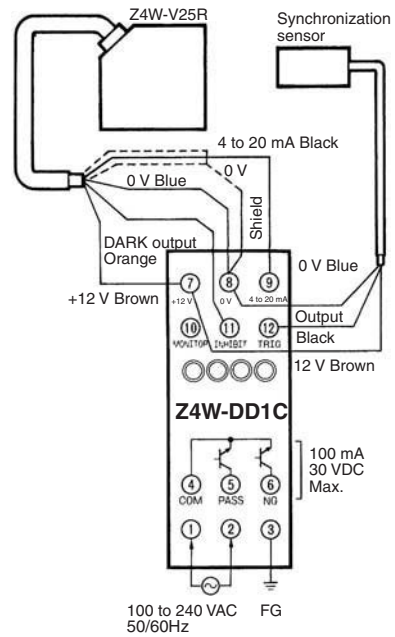

Axis Adjustment

After adjusting the optical axis of the LED Displacement Sensor, adjust the optical axis of the Synchronization Sensor so that the LED Displacement Sensor detects the object at the measurement position in synchronous operation. Since the Linear Sensor Controller operates synchronously on receiving each output signal of the Synchronization Sensor, set the position of the Synchronization Sensor so that the front edge of the object is detected by the Synchronization Sensor.

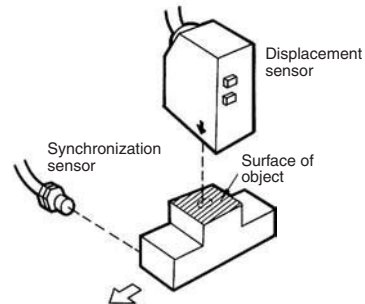

After the optical axis has been adjusted, tighten the mounting screws and secure the Synchronization Sensor firmly. Some Synchronization Sensor models incorporate a sensitivity controller. For the adjustment of such models, refer to the instruction manual for the Synchronization Sensor.

Adjustment and Operation of the Linear Sensor Controller

Control panel of the Linear Sensor Controller

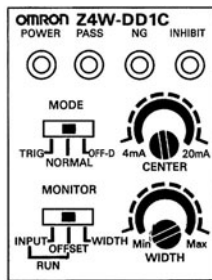

The control panel consists of two switches (MODE and MONITOR), two adjusters (CENTER and WIDTH) and four indicators (POWER, PASS, NG, INHIBIT) for monitoring.

By adjusting the settings of the Linear Sensor Controller and compensating for the position of the LED Displacement Sensor, the size of the object of standard dimensions is registered with the Linear Sensor Controller. With the object of standard dimensions, operate the LED Displacement Sensor as follows:

1. Set the MODE switch to NORMAL.
2. Turn the WIDTH adjuster counterclockwise to the MIN position.
3. Turn the CENTER adjuster clockwise or counterclockwise and set the adjuster to the position where the PASS indicator is lit. If the PASS indicator is lit for a wide range of positions, set the adjuster in the middle of the range. If the PASS indicator does not light with the CENTER adjuster in any position, turn the WIDTH adjuster clockwise slightly.

An object of threshold dimensions or a multimeter can be used to determine the tolerance (use the object where possible).

Determining Settings Using an Object

1. Prepare an object of threshold dimensions (an object with the allowable upper threshold dimensions or with the allowable lower threshold dimensions) to be detected by the LED Displacement Sensor.
2. Set the MODE switch to NORMAL.
3. Turn the WIDTH adjuster counterclockwise to the MIN position. The NG indicator will light.
4. Turn the WIDTH adjuster clockwise slowly to the position where the NG indicator turns OFF. The PASS indicator will light.

Determining Settings Using a Multimeter

Determine the absolute tolerance, A (in mm), and obtain the voltage V_x (V) as follows (example for tolerance of ± 0.5 mm):

1. Set the MONITOR switch to WIDTH.
2. Check the voltage of monitor terminals 10 (positive voltage output) and 8 (negative voltage output) of the Linear Sensor Controller with the multimeter in the 10-VDC or 5-VDC range.
3. Turn the WIDTH adjuster clockwise or counterclockwise to the position where the voltage reaches V_x (obtained from the above formula).

Set the MODE switch to TRIG as follows:

1. Set the MODE switch to TRIG.
2. Set the MONITOR switch to INPUT or OFFSET (RUN).
3. Turn off the power and wire the output terminals (No. 4, 5, and 6).

Dimensions

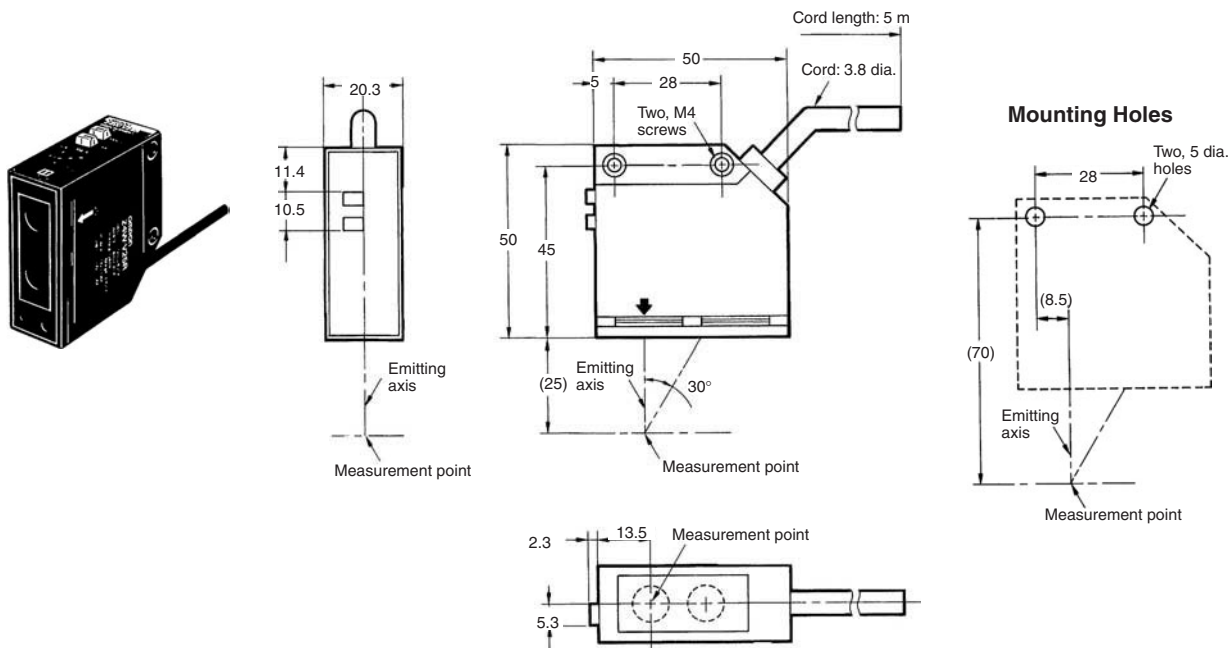

With Mounting Bracket 1

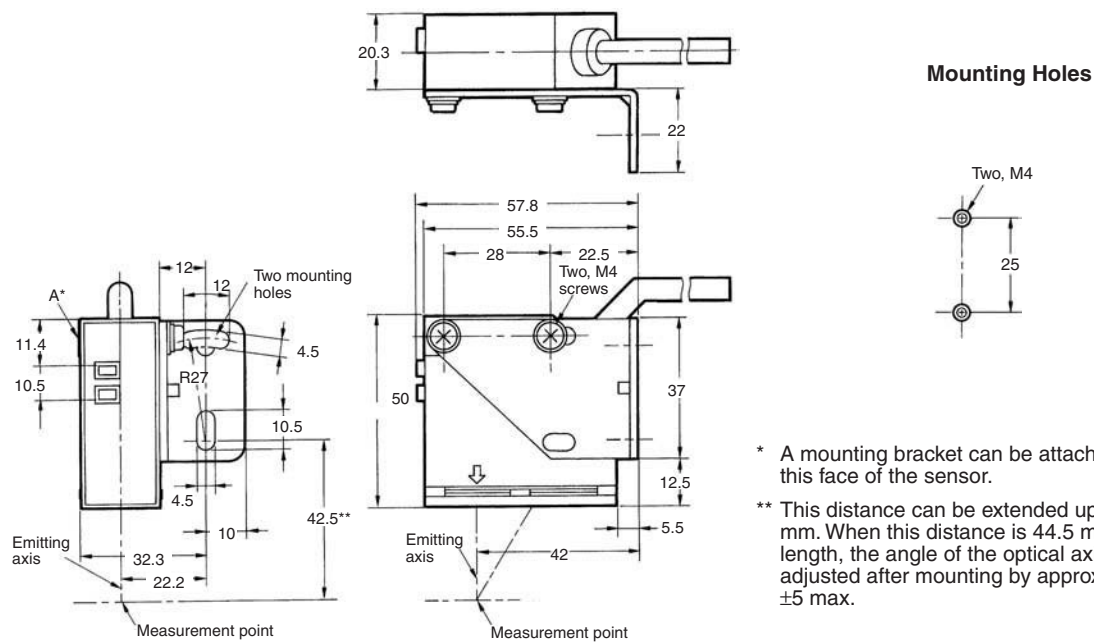

- * A mounting bracket can be attached to this face of the sensor.
- ** This distance can be extended up to 44.5 mm. When this distance is 44.5 mm in length, the angle of the optical axis can be adjusted after mounting by approximately ± 5 max.

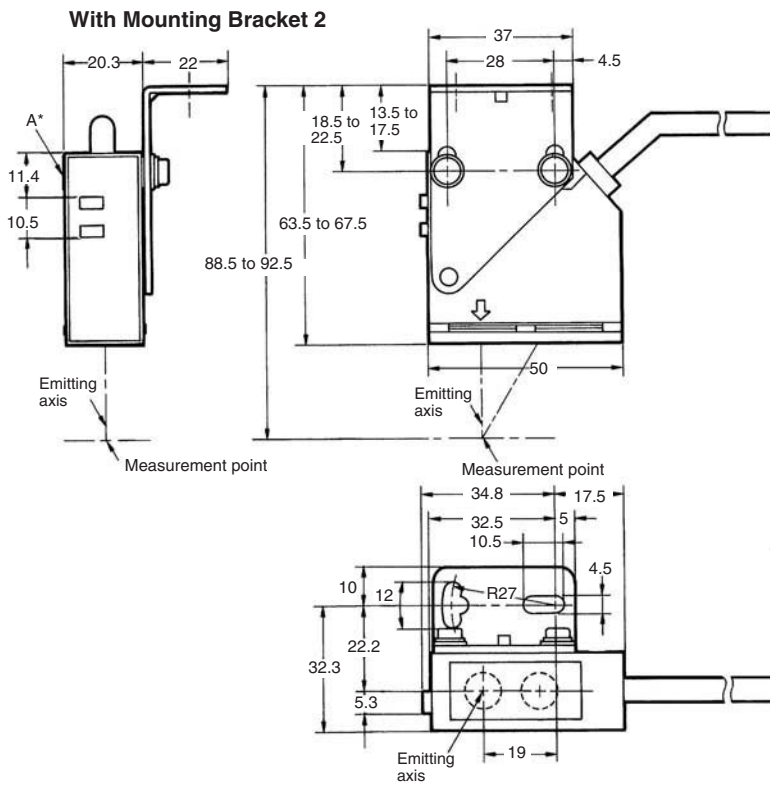

* A mounting bracket can be attached to this face of the sensor.

Installation

■ Controller Connections

Z4W-DD1C

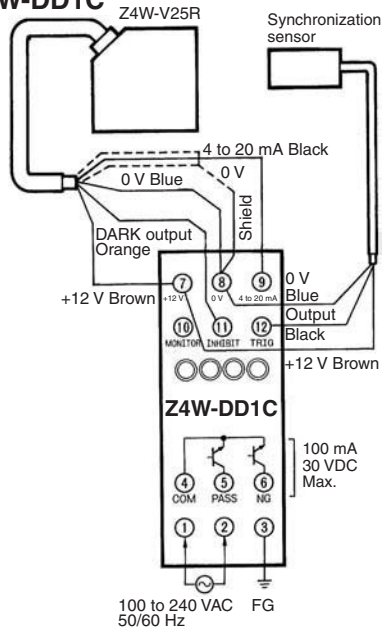

Connection with a S3A-DAK

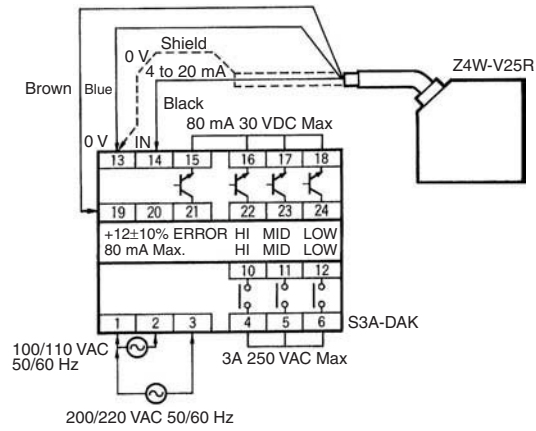

Connection with a K3TX

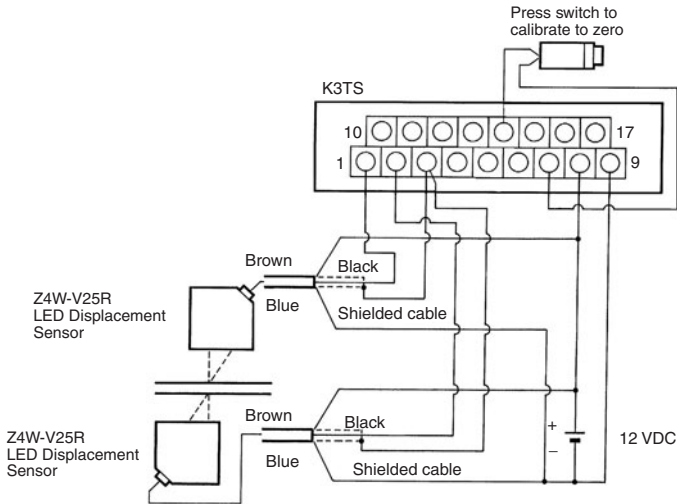

Precautions

Install the Sensor in a clean environment keep the filter (on the front of the Sensor) free from oil and dust. If affected by oil or dust, clean the Sensor as follows:

1. Use a blower brush (used to clean camera lenses) to blow large dust particles from the surface. Do not blow the dust away with your mouth.
2. Use a soft cloth (for lenses) with a little alcohol to remove the remaining dust.
Do not use a scrubbing action when cleaning as a scratch on the filter could result in the Sensor malfunctioning.

Interference

Z4W-V25R LED Displacement Sensors can be installed within close proximity to each other and operate independently without interference (refer to the figures below). However, if they are installed at an oblique angle to each other, interference may result.

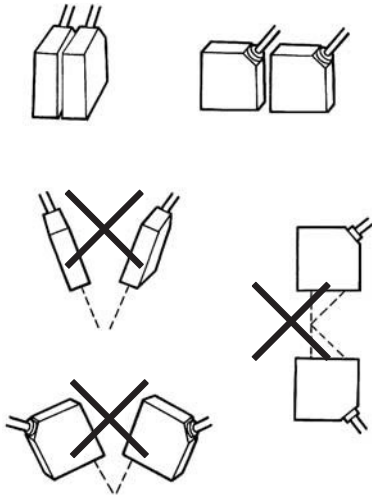

When using the LED Displacement Sensor in combination with another type of Sensor (such as a Photoelectric Sensor), the sensor beams should be as close to perpendicular as possible.

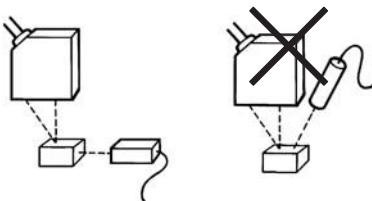

Environment

Refrain from using the LED Displacement Sensor in a strong electromagnetic field or in an environment where the operation of the Sensor is subject to the reflection of intensive light (such as a laser beam or an electric arc welding machine).

The LED Displacement Sensor cannot accurately detect a mirror-like object, a transparent object, one with an extremely small reflection ratio, an object smaller than the diameter of the Sensor's sensing spot, or an inclined object.

Wiring

The power supply cable for the Z4W-V25R should not be wired with high-voltage lines or power lines in order to avoid interference, damage, or malfunction.

Others

The Sensor cannot detect an object accurately if the surface of the object consists of different materials placed next to each other (refer to the figures below). In such case install the Sensor so that the boundaries of the materials and the Sensor are parallel.

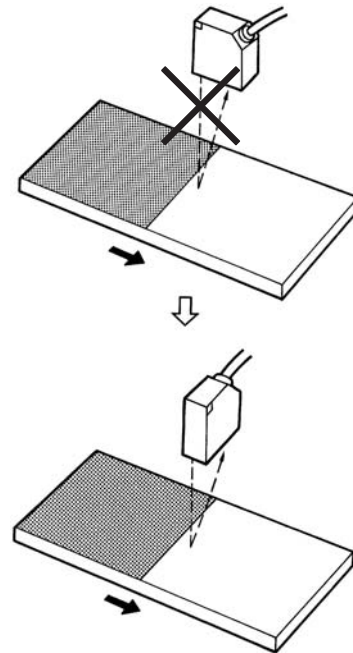

ALL DIMENSIONS SHOWN ARE IN MILLIMETERS.

To convert millimeters into inches, multiply by 0.03937. To convert grams into ounces, multiply by 0.03527.

CSM_3_1_0315
E217-E1-03

In the interest of product improvement, specifications are subject to change without notice.

OMRON Corporation

Industrial Automation Company

Sensing Devices Division H.Q.

Application Sensors Division

Shiokoji Horikawa, Shimogyo-ku,

Kyoto, 600-8530 Japan

Tel: (81)75-344-7068/Fax: (81)75-344-7107