

New!

OMRON

DeviceNet Smart Slaves

Remote I/O Terminals with Transistors

DRT2-ID08(-1)/OD08(-1)/MD16(-1)

MIL Connector Terminals with Transistors

DRT2-ID16ML(-1)/OD16ML(-1)/ID16MLX(-1)/OD16MLX(-1)

Environment-resistive Terminals with Transistors (without detection functions)

DRT2-ID04CL(-1)/OD04CL(-1)/ID08CL(-1)/OD08CL(-1)/

MD16CL(-1)/HD16CL(-1)



Remote Maintenance

The lineup now includes a wide variety of Smart Slaves with different numbers of control points that contribute to production site servicing and repair.



realizing



Use production site information in a variety of applications, such as maintenance and quality control.

OMRON's DRT2-series Smart Slaves do not just input and output ON/OFF signals. They collect a variety of value-added information to help increase the rate of operation without changing the wiring for existing DeviceNet networks. In particular, they allow the separation of control systems and maintenance systems so that maintenance systems can be created independently of control systems.

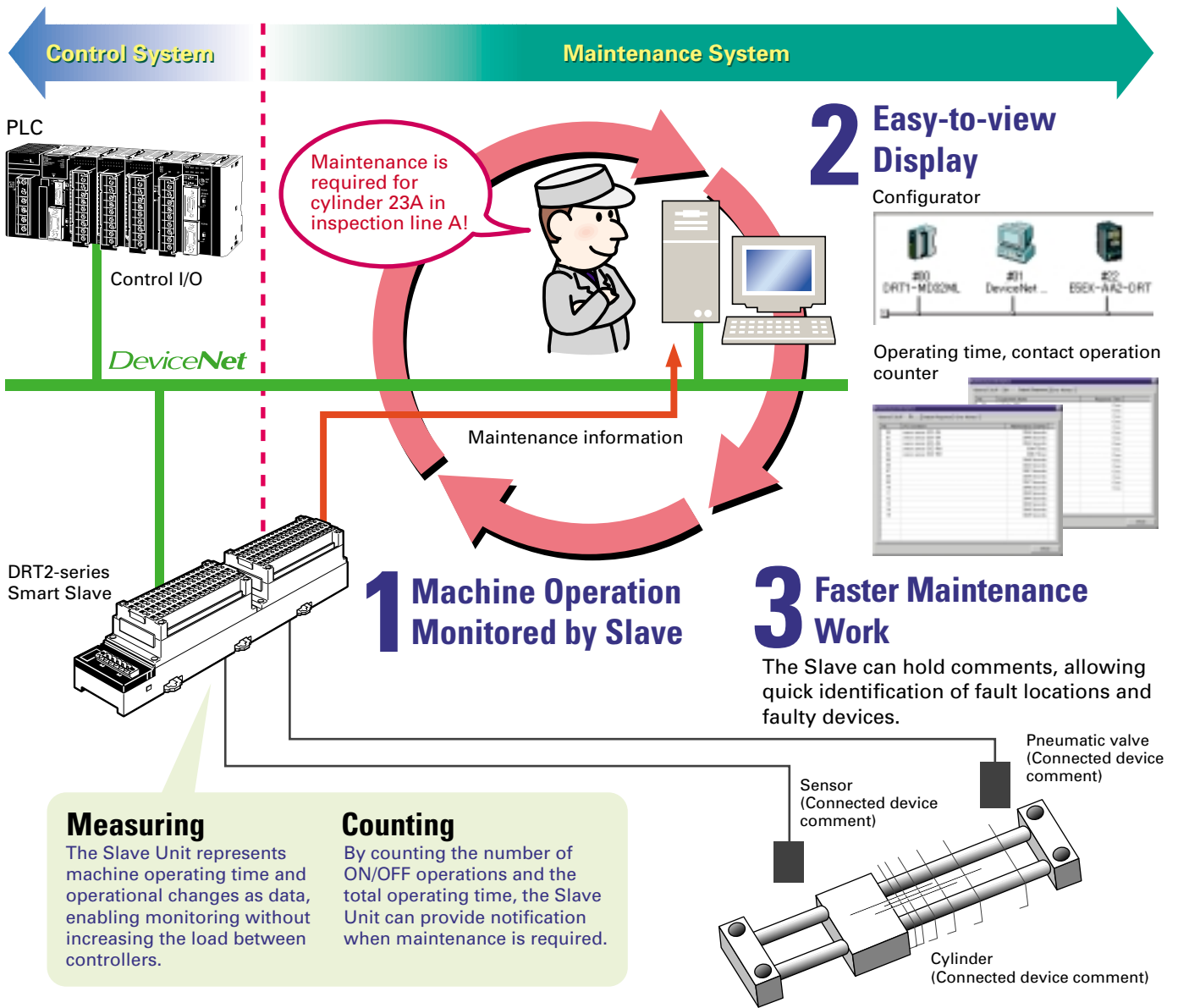

Collect a variety of data from maintenance systems without influencing control systems and productivity.

All data can be converted to electronic format and, by combining with an OMRON PLC (CS/CJ Series), checked directly from Ethernet or the Internet to allow remote maintenance.

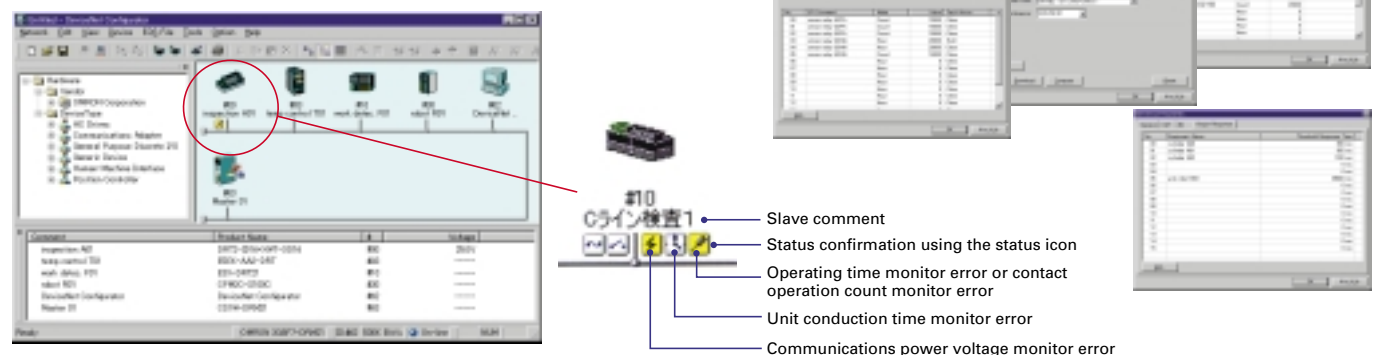

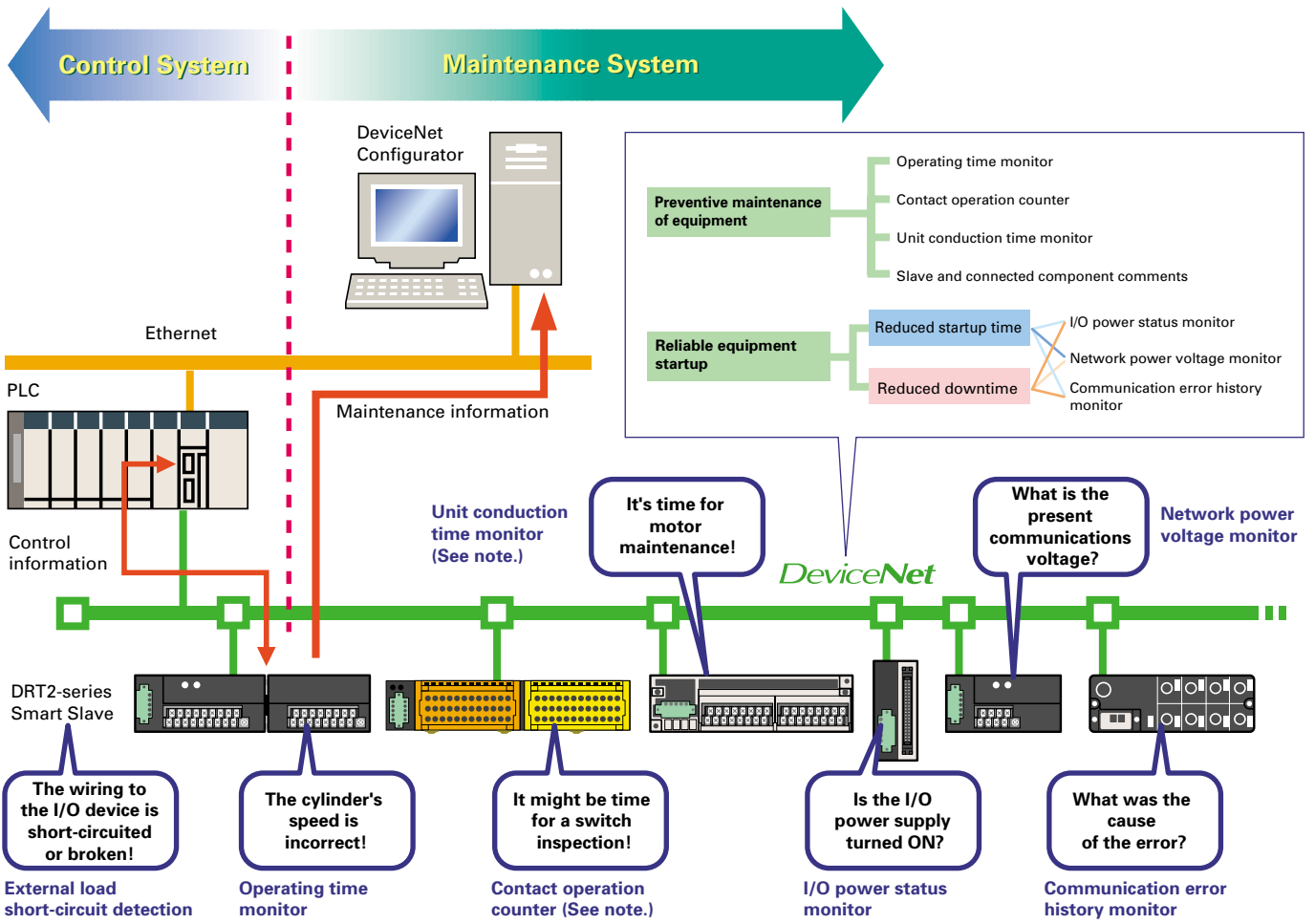

Note: The contact operation counter function and the unit conduction time monitor function cannot be used simultaneously.

Using OMRON Temperature Input Terminals for Maintenance

Failure Prediction and Maintenance

If prolonging the time it takes to reach a certain temperature may degrade equipment:

The operating time of a preset temperature range is counted in 1-s units.

Slaves can notify the Master when a setting is exceeded.

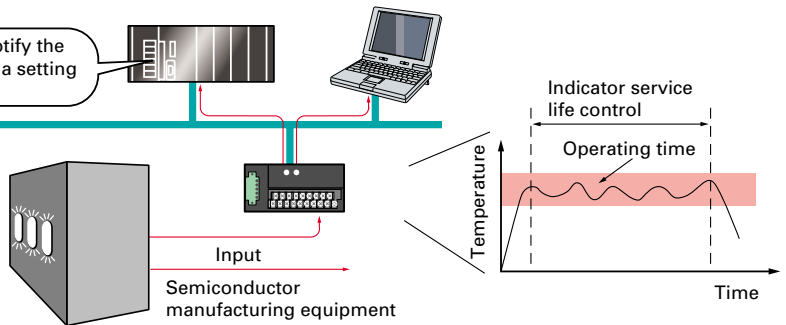

The peaks or valleys of temperature inputs that change in a regular pattern are counted to predict when devices operating with severe temperature swings are due for maintenance.

Short Startup

If it takes too long to modify the ladder program on the Master when a Temperature Sensor is replaced:

Slaves internally convert display values to temperature input values so the Controller program no longer has to be modified to perform this task.

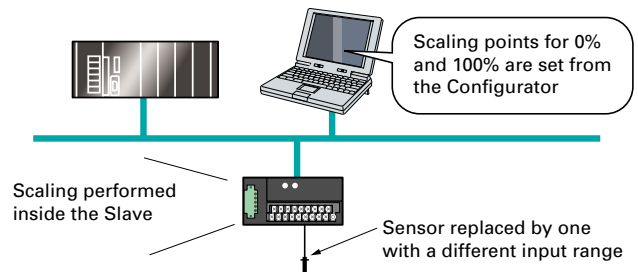

Wide variety of control and maintenance functions using DeviceNet.

Monitor network devices using a DeviceNet Configurator.

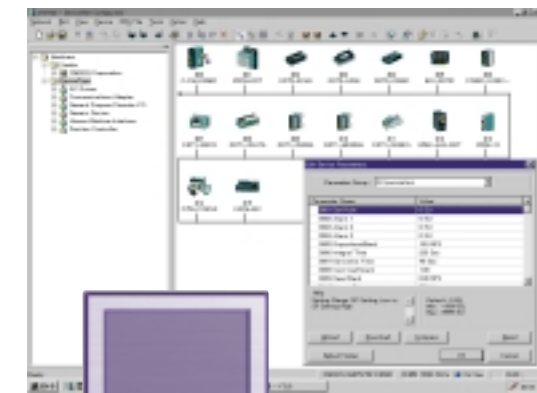

DeviceNet Configurator

- Settings and monitoring for startup
- Settings and monitoring for maintenance



CS/CJ-series DeviceNet Unit

PLC

New Lineup

Models with 8 Input, 8 Output, or 16 I/O Points Added to the Lineup

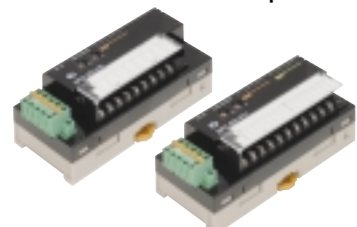

Remote I/O Terminals with Transistors
DRT2-ID08(-1)/OD08(-1)/MD16(-1)

- Collect a variety of data from maintenance systems without influencing control systems and productivity.
- Communications power supply voltage monitor, deterioration due to aging, operating time data, and other information can be easily collected and managed via the network.
- Locations of problems can be easily identified.

Remote I/O Terminals with IP67 High Environmental Resistance



Environment-resistive Terminals with Transistors
DRT2-ID04CL(-1)/OD04CL(-1)/ID08CL(-1)/OD08CL(-1)/MD16CL(-1)/HD16CL(-1)/WD16CL(-1)

- Smart Slave functions provide robust support for effective maintenance and monitoring device operation status.
- The terminals conform to IP67 and use materials selected for resistance to oil and spattering.
- Models with two-output connector are also available to improve ease of connection with hydraulic valve devices.

Terminals with 16 Inputs or Outputs



MIL Connector Terminals with Transistors
DRT2-ID16ML(-1)/OD16ML(-1)/ID16MLX(-1)/OD16MLX(-1)

- Connection with an array of I/O interfaces is achieved by combining adaptor boards for D-Sub or other interfaces.

I/O Control and Maintenance

Board Terminals with MIL Connectors

DRT2-ID32B(-1)
DRT2-OD32B(-1)
DRT2-MD32B(-1)
DRT2-ID32BV(-1)
DRT2-OD32BV(-1)
DRT2-MD32BV(-1)

- First Board-type Smart Slave Terminals
- User boards attach easily to the DRT2-□D32V(-1) using screws.

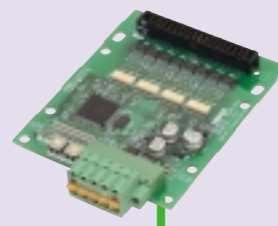

Remote I/O Terminals with Screw-less Clamps

DRT2-ID32SL(H)(-1)
DRT2-OD32SL(H)(-1)
DRT2-MD32SL(H)(-1)

- Wiring is completed in a single action.
- No screw tightening required. Removable terminal blocks.
- Advanced models detect ground faults and broken lines in I/O wiring.
- Applicable wire sizes range from AWG24 to AWG16 (0.2 to 1.25 mm² dia.)

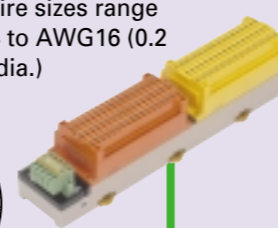
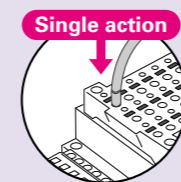

Remote I/O Terminals with Transistors

DRT2-ID16(-1)
DRT2-OD16(-1)
DRT2-ID08(-1) **NEW**
DRT2-OD08(-1) **NEW**
DRT2-MD16(-1) **NEW**

- I/O points can be extended by adding Expansion Units.

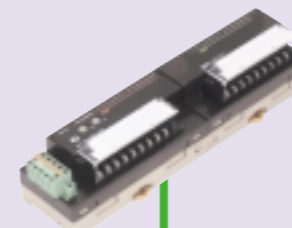

Remote I/O Terminal with Relay Outputs

DRT2-ROS16

- One-step relay exchange
- Operation time monitor function enabled by combining Remote I/O Terminals with Expansion I/O Units.

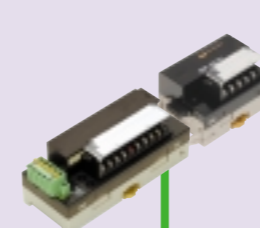

Environment-resistive Terminals with Transistors (with detection functions)

DRT2-ID08C(-1)
DRT2-OD08C(-1)
DRT2-HD16C(-1)

- High resistance to environments (IP67).
- Detecting shorts in the sensor power supply is also possible.



Environment-resistive Terminals with Transistors (without detection functions)

DRT2-ID04CL(-1) **NEW**
DRT2-OD04CL(-1) **NEW**
DRT2-ID08CL(-1) **NEW**
DRT2-OD08CL(-1) **NEW**
DRT2-MD16CL(-1) **NEW**
DRT2-HD16CL(-1) **NEW**
DRT2-WD16CL(-1) **NEW**



Remote I/O Terminals with 3-tier Terminal Blocks

DRT2-ID16TA(-1)
DRT2-OD16TA(-1)
DRT2-MD16TA(-1)

- The 3-tier Terminal Block means that wiring locations are easy to find with no wiring to intermediate terminals.



MIL Connector Terminals

DRT2-ID32ML(-1)
DRT2-OD32ML(-1)
DRT2-MD32ML(-1)
DRT2-ID16ML(-1) **NEW**
DRT2-OD16ML(-1) **NEW**
DRT2-ID16MLX(-1) **NEW**
DRT2-OD16MLX(-1) **NEW**

- Ultra-small 32-point remote terminals (35 x 60 x 80 mm (W x D x H)).



e-CON Connector Terminals

DRT2-ID16S(-1)
DRT2-MD16S(-1)

- Includes industry-standard e-CON connector that can be used to connect prewired sensors without using special tools. (The OMRON XN2 Connector can be used.)

Sensor Input and Maintenance

Analog I/O Terminals

DRT2-AD04/DRT2-AD04H
DRT2-DA02

- The DRT2-AD04H offers high resolution at 1/30,000 (full scale) and insulation between input channels.
- The DRT2-AD04 and DRT2-DA02 support a wide variety of data sampling function, including scaling, peak/bottom hold, top/valley hold, comparator, integral, and differential operation functions.

Analog Control and Maintenance

Temperature Input Terminals

DRT2-TS04T
DRT2-TS04P

- Offers basically the same functions as Analog Input Terminals, such as scaling and comparators. Also provides functions that are available only from Temperature Input Terminals, such as the time in a preset temperature range and temperature difference detection between input channels.

DeviceNet Communications Unit for E5ZN Digital Temperature Controllers

E5ZN-DRT

- Monitoring and setting of Temperature Controller from PLC.
- Batch download of all Temperature Controller parameters from Configurator.

DeviceNet Communications Units/Cards for Inverters

3G3MV-PDRT2 (for 3G3MV Series)
3G3RV-PDRT2 (for 3G3RV Series)

- Frequencies and other specifications can be designated from PLC.
- Monitor-related maintenance possible, including output current (torque) error detection/trace, operation monitor, and general-purpose I/O read.

Monitor Control and Maintenance

Functions Supported by Smart Slaves

Slave name	General-purpose Slaves															General-purpose Slaves						Environment-resistive Slaves						General-purpose Slaves		Analog Slaves			
	Remote I/O Terminals										MIL Connector Terminals			Board Terminals		Screw-less Clamp Terminals						Environment-resistive Terminals						e-con Connector Terminals		Analog I/O Terminals			Temperature Input Terminals
	Models with Transistors					Model with Relay Outputs	Models with 3-tier Terminal Blocks			Models with Transistors			Models with MIL Connectors		Models with Transistors With Detection Functions			Models with Transistors Without Detection Functions			Models with Transistors With Detection Functions			Models with Transistors Without Detection Functions			DRT2-□D16S(-1)		DRT2-AD04	DRT2-AD04H	DRT2-DA02	DRT2-TS04□	
	DRT2-□D16(-1)		DRT2-□D08(-1)		DRT2-MD16(-1)	DRT2-ROS16	DRT2-□D16TA(-1)			DRT2-□D32ML(-1) DRT2-□D16ML(-1) DRT2-□D16MLX(-1)			DRT2-□D32B(-1) DRT2-□D32BV(-1)		DRT2-□D32SLH(-1)			DRT2-□D32SL(-1)			DRT2-□D08C(-1) DRT2-□D16C(-1)			DRT2-□D04CL(-1) DRT2-□D08CL(-1) DRT2-□D16CL(-1)									
Input		Output		Input/output	Output	Input	Output	Input/output	Input	Output	Input/output	Input	Output	Input/output	Input	Output	Input/output	Input	Output	Input/output	Input	Output	Input/output	Input	Input/output	Input	Output	Input					
Operating time monitor	○ (Inputs and outputs only)		---		○	○	○	○	○	○	○	○	○	○	○	○	○	○	○	○	○	○	○	○	○	○	○	○	○				
Contact operation count monitor					○	○	○	○	○	○	○	○	○	○	○	○	○	○	○	○	○	○	○	○	○	○	○	○	○				
Unit conduction time monitor					○	○	○	○	○	○	○	○	○	○	○	○	○	○	○	○	○	○	○	○	○	○	○	○	○				
Total RUN (ON) time monitor					○	○	○	○	○	○	○	○	○	○	○	○	○	○	○	○	○	○	○	○	○	○	○	○	○				
Unit comment					○	○	○	○	○	○	○	○	○	○	○	○	○	○	○	○	○	○	○	○	○	○	○	○	○				
Connected device comment					○	○	○	○	○	○	○	○	○	○	○	○	○	○	○	○	○	○	○	○	○	○	○	○	○				
Network power voltage monitor					○	○	○	○	○	○	○	○	○	○	○	○	○	○	○	○	○	○	○	○	○	○	○	○	○				
I/O power status monitor			○		---	○	○	○	○	○	○	○	○	○	○	○	○	○	○	○	○	○	○	○	○	○	○	○	○				
Communications error history monitor					○	○	○	○	○	○	○	○	○	○	○	○	○	○	○	○	○	○	○	○	○	○	○	○	○				
Input filter	○	---	○	---	○	---	○	---	○	---	○	---	○	---	○	---	○	---	○	---	○	---	○	---	○	---	○	---	○				
Prevention of malfunctions due to sensor inrush current	○	---	○	---	○	---	○	---	○	---	○	---	○	---	○	---	○	---	○	---	○	---	○	---	○	---	○	---	○				
Sensor power short-circuit detection					---	---	---	---	---	---	---	---	---	---	○	---	○	---	---	---	---	---	---	---	---	---	---	---	---				
External load short-circuit detection					---	---	---	---	---	---	---	---	---	---	---	○ (See note.)	---	---	---	---	---	---	---	---	---	---	---	---	---				
Sensor disconnection detection					---	---	---	---	---	---	---	---	---	---	○	---	○	---	---	---	---	---	---	---	---	---	---	---	---				
External load disconnection detection					---	---	---	---	---	---	---	---	---	---	---	○	○	---	---	---	---	---	---	---	---	---	---	---	---				
Removable terminal blocks					○	---	---	---	---	---	---	---	---	---	---	---	○	---	---	---	---	---	---	---	---	○	---	---	○				
Automatic baud rate detection					○	---	---	---	---	---	---	---	---	---	---	---	---	---	---	---	---	---	---	---	---	---	---	---	---				
Unit power supply wiring not required					○	---	---	---	---	---	---	---	---	---	---	---	---	---	---	---	---	---	---	---	---	---	---	---	---				
Power supply wiring not required for input devices					---	---	---	---	---	---	---	---	---	---	---	---	---	---	---	---	---	---	---	---	---	---	---	---	---				
Expansion I/O Units mountable	○	---			○	---	---	---	---	---	---	---	---	---	---	---	---	---	---	---	---	---	---	---	---	---	---	---	---				
Scaling					---	---	---	---	---	---	---	---	---	---	---	---	---	---	---	---	---	---	---	---	---	---	---	---	---				
User calibration					---	---	---	---	---	---	---	---	---	---	---	---	---	---	---	---	---	---	---	---	---	---	---	---	---				
Last maintenance date					○	---	---	---	---	---	---	---	---	---	---	---	---	---	---	---	---	---	---	---	---	---	---	---	---				
Integral function					---	---	---	---	---	---	---	---	---	---	---	---	---	---	---	---	---	---	---	---	---	---	---	---	---				
Moving average processing					---	---	---	---	---	---	---	---	---	---	---	---	---	---	---	---	---	---	---	---	---	○	---	---	○				
Number of AD conversion points setting (conversion cycle)					---	---	---	---	---	---	---	---	---	---	---	---	---	---	---	---	---	---	---	---	---	---	---	---	---				
Peak/bottom hold					---	---	---	---	---	---	---	---	---	---	---	---	---	---	---	---	---	---	---	---	---	---	---	---	---				
Top/valley hold					---	---	---	---	---	---	---	---	---	---	---	---	---	---	---	---	---	---	---	---	---	---	---	---	---				
Change rate calculations					---	---	---	---	---	---	---	---	---	---	---	---	---	---	---	---	---	---	---	---	---	---	---	---	---				
Comparator function					---	---	---	---	---	---	---	---	---	---	---	---	---	---	---	---	---	---	---	---	---	---	---	---	---				
Setting output value for errors					---	---	---	---	---	---	---	---	---	---	---	---	---	---	---	---	---	---	---	---	---	---	---	---	---				
Top/valley count					---	---	---	---	---	---	---	---	---	---	---	---	---	---	---	---	---	---	---	---	---	---	---	---	---				
Operating time in a preset temperature range					---	---	---	---	---	---	---	---	---	---	---	---	---	---	---	---	---	---	---	---	---	---	---	---	---				
Temperature difference detection between input channels					---	---	---	---	---	---	---	---	---	---	---	---	---	---	---	---	---	---	---	---	---	---	---	---	---				

○: Yes, ---: No

Note: The contact operation count monitor and the total RUN (ON) time monitor cannot be used at the same time for one contact. External load detection is supported only by the DRT2-MD32SLH-1 and DRT2-OD32SLH-1.

Specifications

Communications power supply voltage	11 to 25 VDC (supplied from communications connector)	
I/O power supply voltage	20.4 to 26.4 VDC (24 VDC -15% to +10%)	
Noise immunity	Conforms to IEC61000-4-4, 2 kV (power lines)	
Vibration resistance	10 to 60 Hz, 0.7-mm double amplitude, 60 to 150 Hz, 50 ms ² for 80 min each in the X, Y, and Z directions	
Shock resistance	150m/s ² , 6 directions, 3 times each	
Dielectric strength	500 VAC (between isolated circuits)	
Insulation resistance	20 MΩ min. (between isolated circuits)	
Ambient operating temperature	-10 to 55°C	
Ambient operating humidity	25 to 85%	
Ambient operating atmosphere	No corrosive gases	
Ambient storage temperature	-20 to 65°C	
Degree of protection	IP67	
Mounting method	DRT2-□D08□-1/□D16(-1): DRT2-□D32ML(-1)/□D16ML(-1): DRT2-□D04CL(-1)/□D08CL(-1)/□D16CL(-1):	35-mm DIN Track 35-mm DIN Track M5 screws mounting (front or back)
Screw tightening torque	DRT2-□D08(-1)/□D16(-1): DRT2-□D32ML(-1)/□D16ML(-1): DRT2-□D04CL(-1)/□D08CL(-1)/□D16CL(-1):	M3 (power supply and I/O terminals): 0.3 to 0.5 N-m M2 (communications connector screws): 0.26 to 0.3 N-m, M3 (screw terminals): 0.3 to 0.5N-m Round connectors (communications connector, power supply, and I/O): 0.39 to 0.49 N-m M5 (Unit mounting from the front): 1.47 to 1.96 N-m

Input Specifications

Remote I/O Terminals with Transistors

Terminals with 8 Inputs

Item	Model	DRT2-ID08(-1)
Input current		6.0 mA max. per point at 24 VDC
ON delay time		1.5 ms max.
OFF delay time		1.5 ms max.
ON voltage	NPN	15 VDC min. (between each input terminal and V)
	PNP	15 VDC min. (between each input terminal and G)
OFF voltage	NPN	5 VDC max. (between each input terminal and V)
	PNP	5 VDC min. (between each input terminal and G)
OFF current		1.0 mA max.
Isolation method		Photocoupler isolation
Input indicator		Yellow LED indicator

Terminals with 8 Inputs/8 Outputs

Item	Model	DRT2-MD16	DRT2-MD16-1
Internal I/O common		NPN	PNP
Number of I/O points		8 inputs	
ON voltage		15 VDC min. (between each input terminal and V)	15 VDC min. (between each input terminal and G)
OFF voltage		5 VDC max. (between each input terminal and V)	5 VDC min. (between each input terminal and G)
OFF current		1 mA max.	
Input current		6.0 mA max. per point at 24 VDC 3.0 mA max. per point at 17 VDC	
ON delay time		1.5 ms max.	
OFF delay time		1.5 ms max.	
Number of points per common		8 points per common	

MIL Connector Terminals with Transistors

Terminals with 16 Inputs, with Connectors

Item	Model	DRT2-ID16ML DRT2-ID16MLX	DRT2-ID16ML-1 DRT2-ID16MLX-1
Internal I/O common		NPN	PNP
Number of I/O points		16 inputs	
ON voltage		17 VDC min. (between each input terminal and V)	17 VDC min. (between each input terminal and G)
OFF voltage		5 VDC max. (between each input terminal and V)	15 VDC min. (between each input terminal and G)
OFF current		1 mA max.	
Input current		6.0 mA max. per point at 24 VDC 3.0 mA max. per point at 17 VDC	
ON delay time		1.5 ms max.	
OFF delay time		1.5 ms max.	
Max. number of simultaneous ON input points		16	
Number of points per common		16 points per common	

Standard Environment-resistive Terminals and Environment-resistive Terminals with Transistors

Terminals with 4 Inputs

Item	Model	DRT2-ID04CL	DRT2-ID04CL-1
Internal I/O common		NPN	PNP
Number of I/O points		4 inputs	
ON voltage		15 VDC min. (between each input terminal and V)	15 VDC min. (between each input terminal and G)
OFF voltage		5 VDC max. (between each input terminal and V)	5 VDC min. (between each input terminal and G)
OFF current		1 mA max.	
Input current		6.0 mA max. per point at 24 VDC 3.0 mA max. per point at 17 VDC	
I/O power supply voltage		20.4 to 26.4 VDC (24 VDC, -15 to +10%)	
ON delay time		1.5 ms max.	
OFF delay time		1.5 ms max.	
Number of points per common		4 points per common	

Terminals with 8 Inputs

Item	Model	DRT2-ID08CL	DRT2-ID08CL-1
Internal I/O common		NPN	PNP
Number of I/O points		8 inputs	
ON voltage		15 VDC min. (between each input terminal and V)	15 VDC min. (between each input terminal and G)
OFF voltage		5 VDC max. (between each input terminal and V)	5 VDC min. (between each input terminal and G)
OFF current		1 mA max.	
Input current		6.0 mA/6.0 mA max. per point at 24 VDC 3.0 mA max. per point at 17 VDC	
I/O power supply voltage		20.4 to 26.4 VDC (24 VDC, -15 to +10%)	
ON delay time		1.5 ms max.	
OFF delay time		1.5 ms max.	
Number of points per common		8 points per common	

Terminals with 16 Inputs

Item	Model	DRT2-HD16CL	DRT2-HD16CL-1
Internal I/O common		NPN	PNP
Number of I/O points		16 inputs	
ON voltage		15 VDC min. (between each input terminal and V)	15 VDC min. (between each input terminal and G)
OFF voltage		5 VDC max. (between each input terminal and V)	15 VDC min. (between each input terminal and G)
OFF current		1 mA max.	
Input current		6.0 mA max. per point at 24 VDC 3.0 mA max. per point at 17 VDC	
I/O power supply voltage		20.4 to 26.4 VDC (24 VDC, -15 to +10%)	
ON delay time		1.5 ms max.	
OFF delay time		1.5 ms max.	
Number of points per common		16 points per common	

Terminals with 8 Inputs/8 Outputs

Item	Model	DRT2-MD16CL	DRT2-MD16CL-1
Internal I/O common		NPN	PNP
Number of I/O points		8 inputs	
ON voltage		15 VDC min. (between each input terminal and V)	15 VDC min. (between each input terminal and G)
OFF voltage		5 VDC max. (between each input terminal and V)	5 VDC min. (between each input terminal and G)
OFF current		1 mA max.	
Input current		6.0 mA max. per point at 24 VDC 3.0 mA max. per point at 17 VDC	
I/O power supply voltage		20.4 to 26.4 VDC (24 VDC, -15 to +10%)	
ON delay time		1.5 ms max.	
OFF delay time		1.5 ms max.	
Number of points per common		8 points per common	

Output Specifications

Remote I/O Terminals with Transistors

Terminals with 8 Outputs

Item	Model	DRT2-OD08(-1)	
Rated output current		0.5 A per point, 4.0 A per common	
ON delay time		0.5 ms max.	
OFF delay time		1.5 ms max.	
Residual voltage		1.2 V max.	
Leakage current		0.1 mA max.	
Isolation method		Photocoupler isolation	
Output indicator		Yellow LED indicator	

Terminals with 8 Inputs/8 Outputs

Item	Model	DRT2-MD16	DRT2-MD16-1
Internal I/O common		NPN	PNP
Number of I/O points		8 outputs	
Rated output current		0.5 A per point, 4 A per common	
Residual voltage		1.2 V max. (0.5 A DC between each output terminal and G)	1.2 V max. (0.5 A DC between each output terminal and V)
Leakage current		0.1 mA max.	
ON delay time		0.5 ms max.	
OFF delay time		1.5 ms max.	
Number of points per common		8 points per common	

MIL Connector Terminals with Transistors

Terminals with 16 Outputs, with Connectors

Item	Model	DRT2-OD16ML DRT2-OD16MLX	DRT2-OD16ML-1 DRT2-OD16MLX-1
Internal I/O common		NPN	PNP
Number of I/O points		16 outputs	
Rated output current		0.3 A per point, 2 A per common (See note.)	
Residual voltage		1.2 V max. (0.3 A DC between each output terminal and G)	1.2 V max. (0.3 A DC between each output terminal and V)
Leakage current		0.1 mA max.	
ON delay time		0.5 ms max.	
OFF delay time		1.5 ms max.	
Number of points per common		16 points per common	

Note: Make sure the total external load current does not exceed 2 A.
Make sure that the V and G terminals do not exceed 1 A per terminal.

Standard Environment-resistive Terminals and Environment-resistive Terminals with Transistors

Terminals with 4 Outputs

Item	Model	DRT2-OD04CL	DRT2-OD04CL-1
Internal I/O common		NPN	PNP
Number of I/O points		4 outputs	
Rated output current		0.5 A per point, 4 A per common	
Residual voltage		1.2 V max. (0.5 A DC between each output terminal and G)	1.2 V max. (0.5 A DC between each output terminal and V)
Leakage current		0.1 mA max.	
I/O power supply voltage		20.4 to 26.4 VDC (24 VDC, -15 to +10%)	
ON delay time		0.5 ms max.	
OFF delay time		1.5 ms max.	
Number of points per common		4 points per common	

Terminals with 8 Outputs

Item	Model	DRT2-OD08CL	DRT2-OD08CL-1
Internal I/O common		NPN	PNP
Number of I/O points		8 outputs	
Rated output current		0.5 A per point, 4 A per common	
Residual voltage		1.2 V max. (0.5 A DC between each output terminal and G)	1.2 V max. (0.5 A DC between each output terminal and V)
Leakage current		0.1 mA max.	
I/O power supply voltage		20.4 to 26.4 VDC (24 VDC, -15 to +10%)	
ON delay time		0.5 ms max.	
OFF delay time		1.5 ms max.	
Number of points per common		8 points per common	

Terminals with 16 Outputs

Item	Model	DRT2-WD16CL	DRT2-WD16CL-1
Internal I/O common		NPN	PNP
Number of I/O points		16 outputs	
Rated output current		0.5 A per point, 4 A per common	
Residual voltage		1.2 V max. (0.5 A DC between each output terminal and G)	1.2 V max. (0.5 A DC between each output terminal and V)
Leakage current		0.1 mA max.	
I/O power supply voltage		20.4 to 26.4 VDC (24 VDC, -15 to +10%)	
ON delay time		0.5 ms max.	
OFF delay time		1.5 ms max.	
Number of points per common		16 points per common	

Terminals with 8 Inputs/8 Outputs

Item	Model	DRT2-MD16CL	DRT2-MD16CL-1
Internal I/O common		NPN	PNP
Number of I/O points		8 outputs	
Rated output current		0.5 A per point, 4 A per common	
Residual voltage		1.2 V max. (0.5 A DC between each output terminal and G)	1.2 V max. (0.5 A DC between each output terminal and V)
Leakage current		0.1 mA max.	
I/O power supply voltage		20.4 to 26.4 VDC (24 VDC, -15 to +10%)	
ON delay time		0.5 ms max.	
OFF delay time		1.5 ms max.	
Number of points per common		8 points per common	

Internal Circuit Configuration

Remote I/O Terminals with Transistors

DRT2-ID08 (NPN)

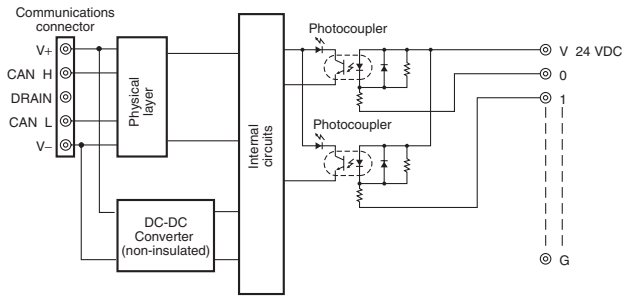

DRT2-ID08-1 (PNP)

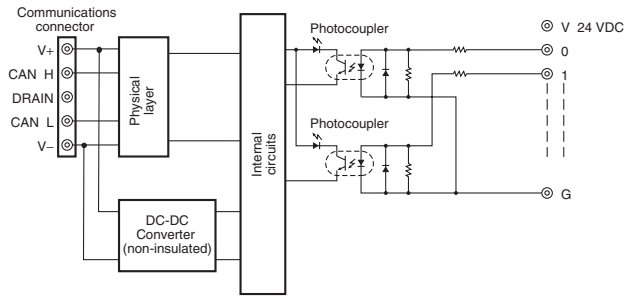

DRT2-OD08 (NPN)

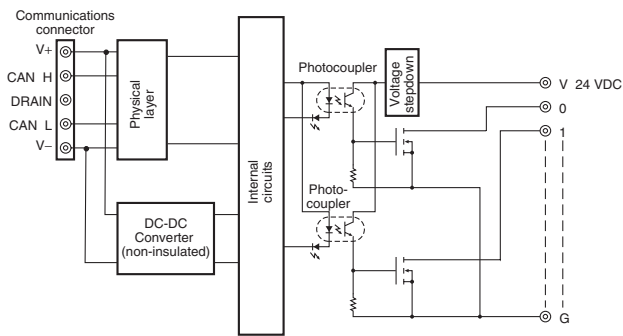

DRT2-OD08-1 (PNP)

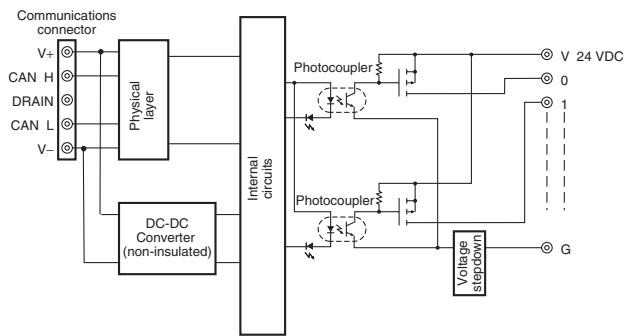

DRT2-MD16 (NPN)

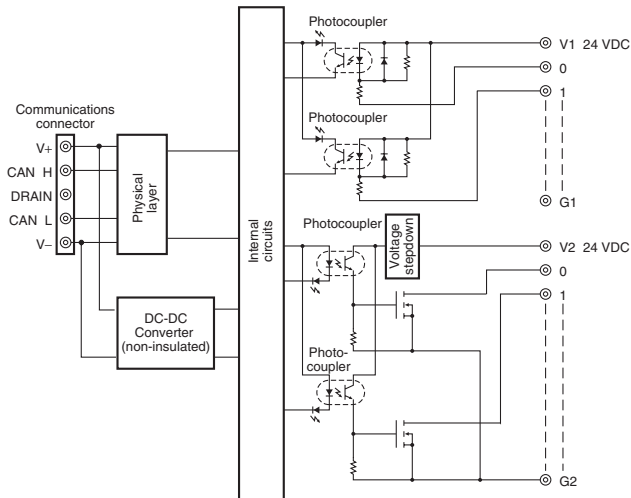

DRT2-MD16-1 (PNP)

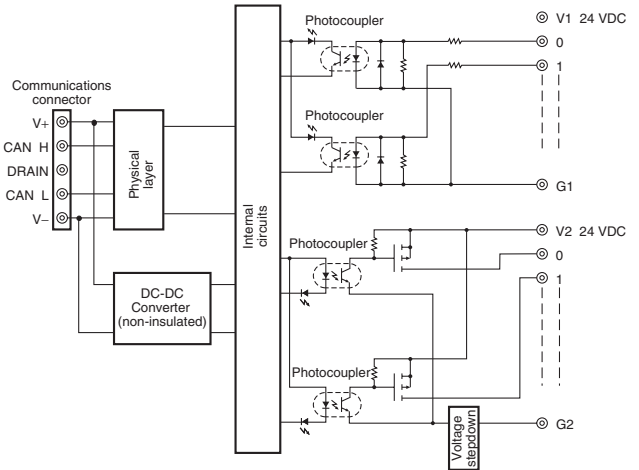

■ MIL Connector Terminals with Transistors

DRT2-ID16ML(X)

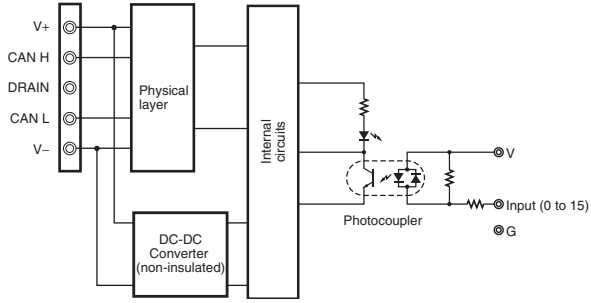

DRT2-ID16ML(X)-1

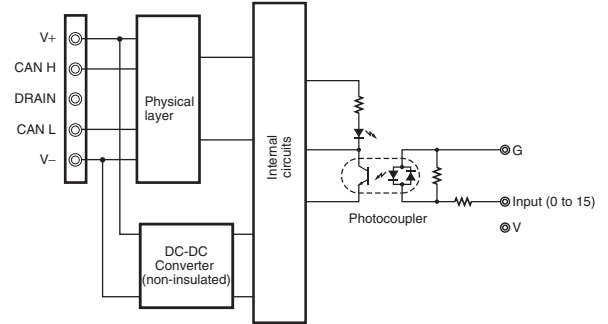

DRT2-OD16ML(X)

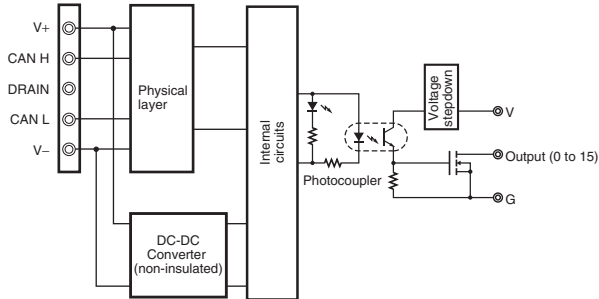

DRT2-OD16ML(X)-1

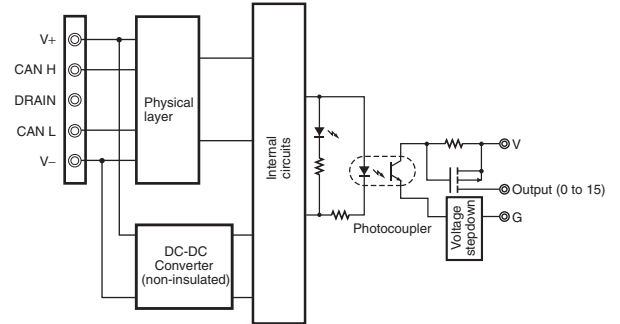

■ Standard Environment-resistive Terminals and Environment-resistive Terminals with Transistors

DRT2-ID04CL (NPN)

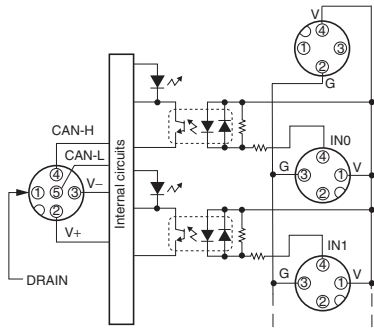

DRT2-ID04CL-1 (PNP)

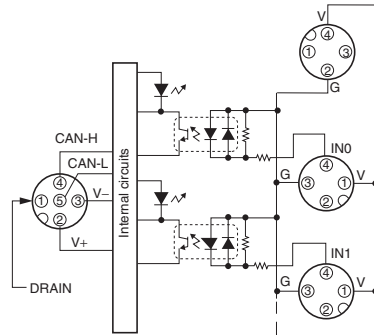

DRT2-OD04CL (NPN)

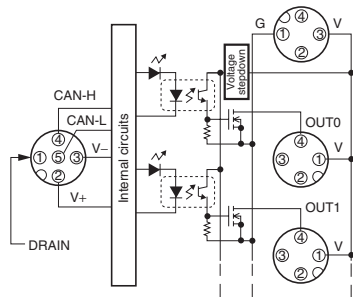

DRT2-OD04CL-1 (PNP)

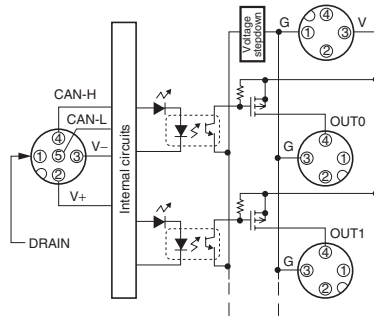

DRT2-ID08CL (NPN)

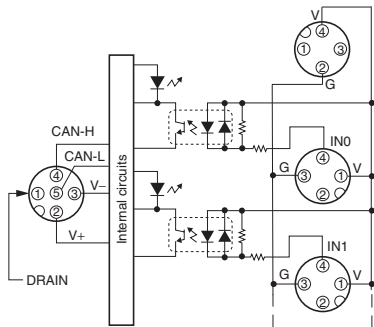

DRT2-ID08CL-1 (PNP)

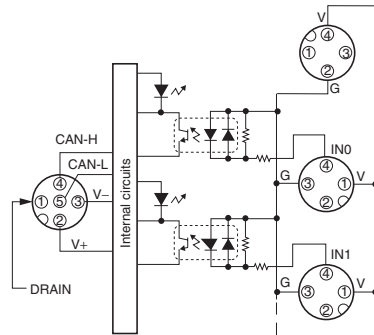

DRT2-OD08CL (NPN)

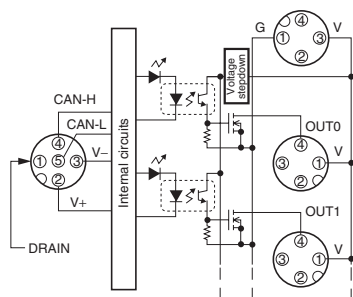

DRT2-OD08CL-1 (PNP)

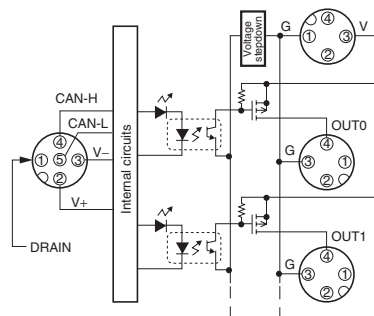

DRT2-HD16CL (NPN)

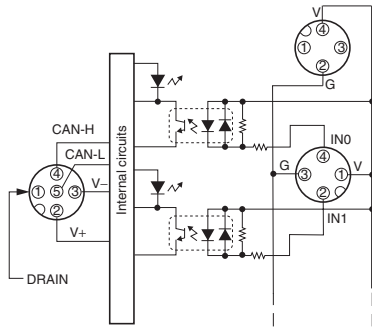

DRT2-HD16CL-1 (PNP)

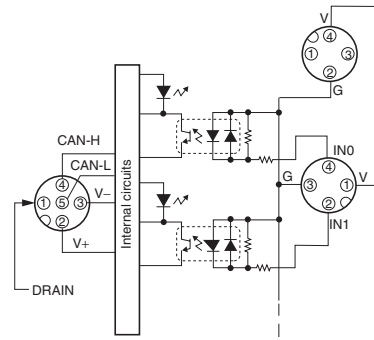

DRT2-WD16CL (NPN)

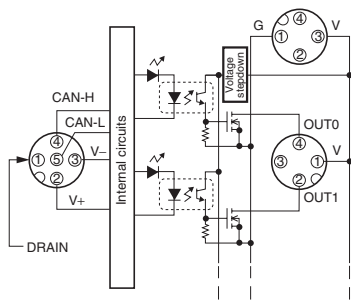

DRT2-WD16CL-1 (PNP)

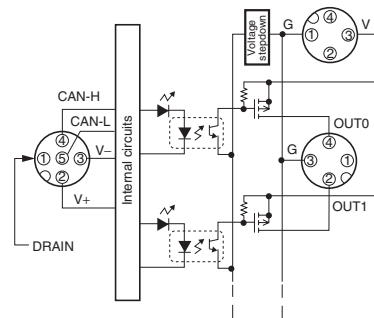

DRT2-MD16CL (NPN)

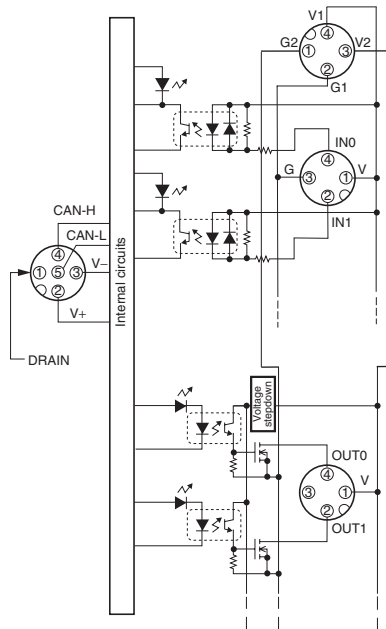

DRT2-MD16CL-1 (PNP)

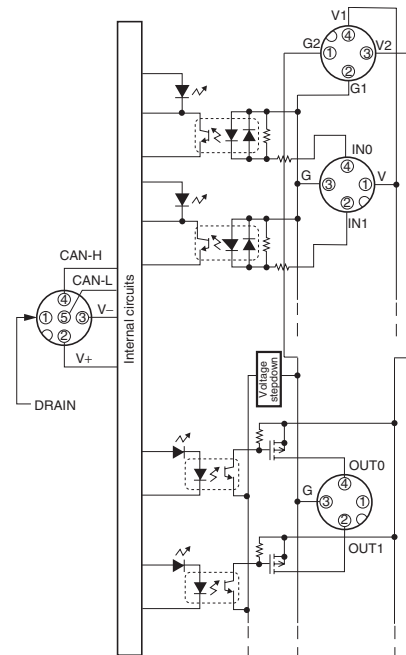

Dimensions

■ Remote I/O Terminals with Transistors

● Remote I/O Terminals

- DRT2-ID08(-1)
- DRT2-OD08(-1)
- DRT2-MD16(-1)

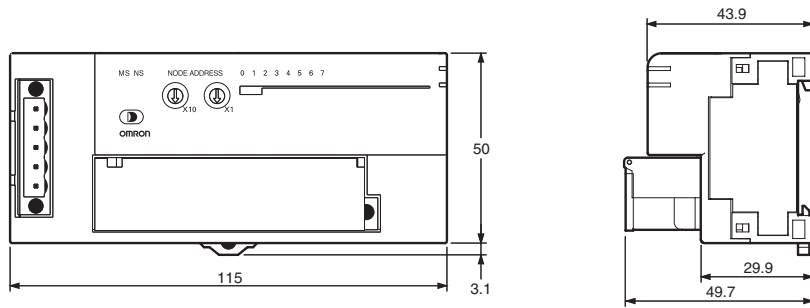

■ MIL Connector Terminals with Transistors

- DRT2-ID16ML(-1)
- DRT2-OD16ML(-1)
- DRT2-ID16MLX(-1)
- DRT2-OD16MLX(-1)

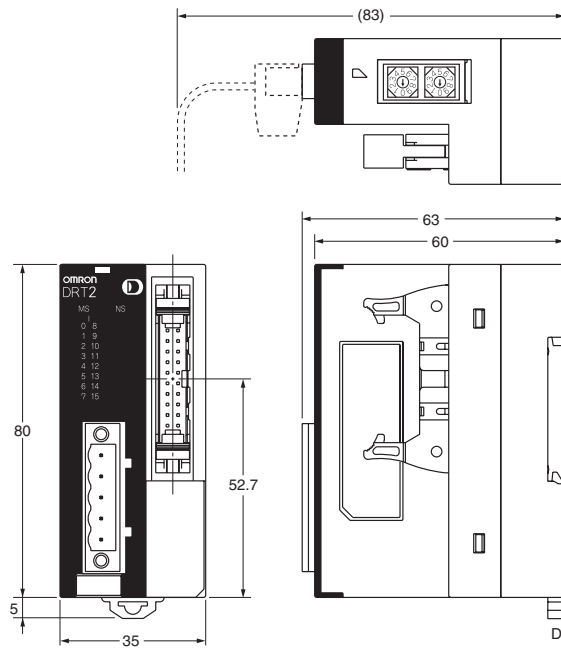

Dimensions inside parentheses are for reference only.

■ Standard Environment-resistive Terminals and Environment-resistive Terminals with Transistors

- DRT2-ID04CL(-1)
- DRT2-OD04CL(-1)

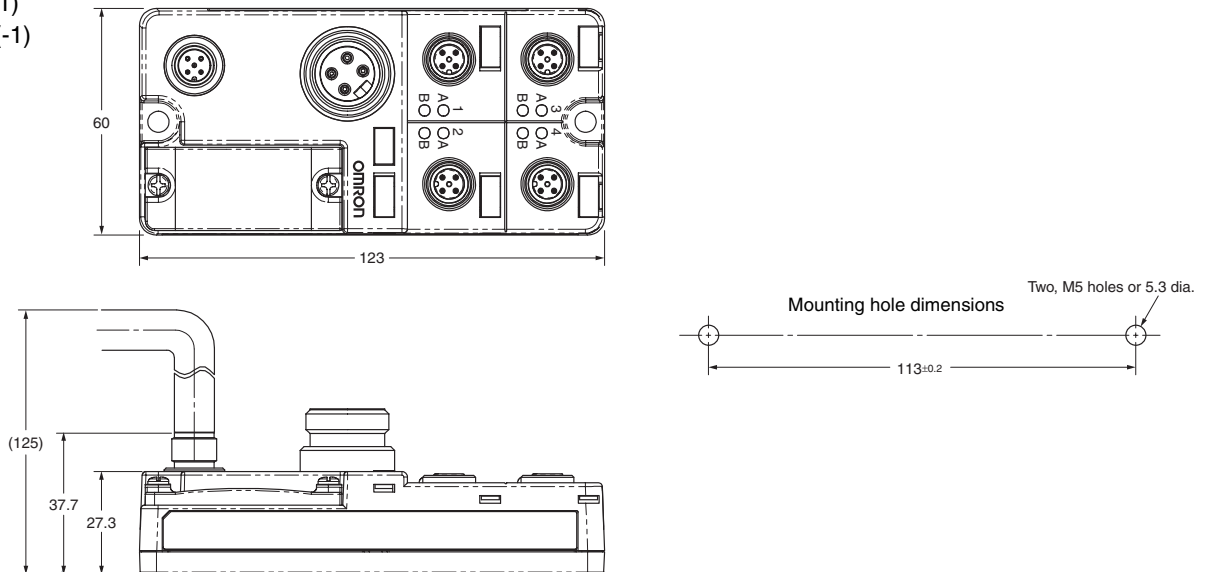

- DRT2-ID08CL(-1)
- DRT2-OD08CL(-1)
- DRT2-HD16CL(-1)
- DRT2-WD16CL(-1)
- DRT2-MD16CL(-1)

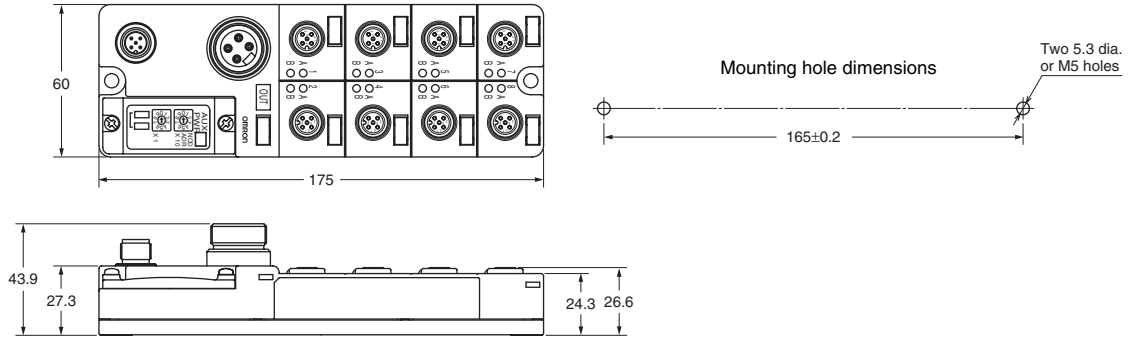

Wiring Diagrams

Remote I/O Terminals with Transistors

DRT2-MD16 (NPN)

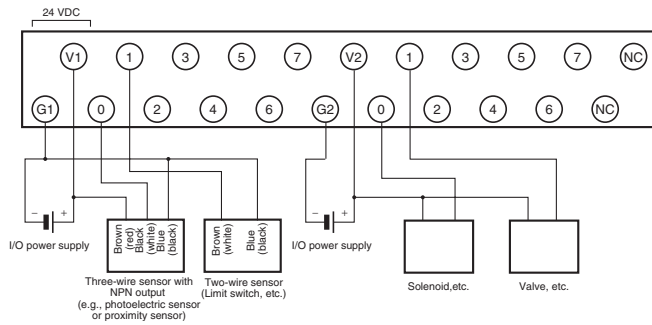

DRT2-MD16-1 (PNP)

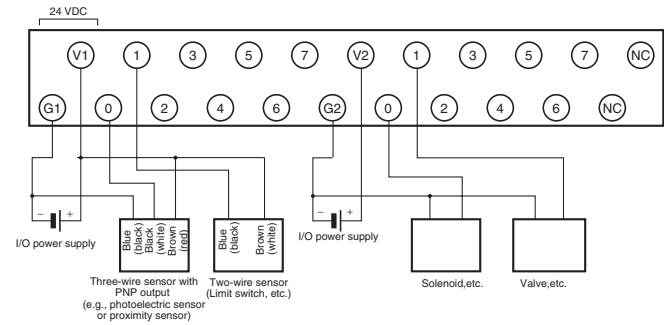

DRT2-ID08 (NPN)

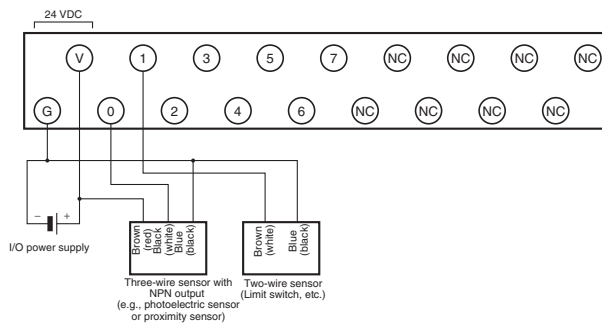

DRT2-ID08-1 (PNP)

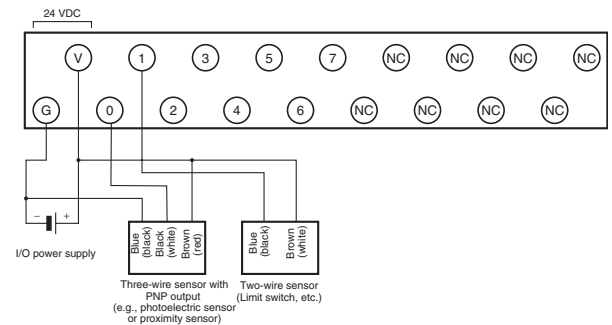

DRT2-OD08 (NPN)

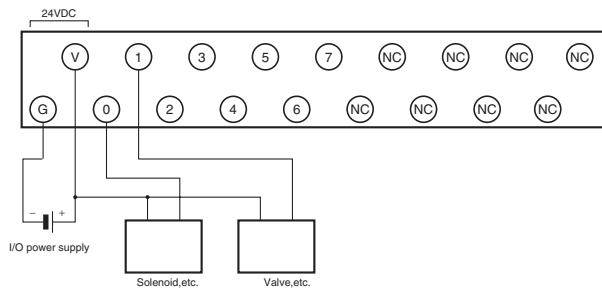

DRT2-OD08-1 (PNP)

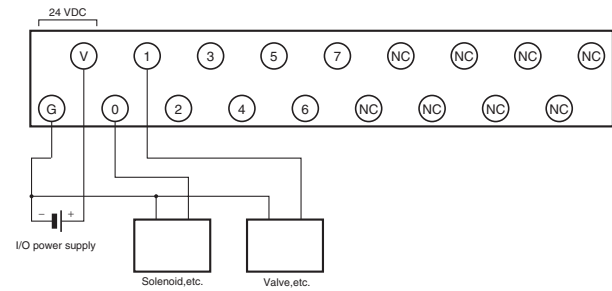

■ MIL Connector Terminals with Transistors

DRT2-ID16ML(X)

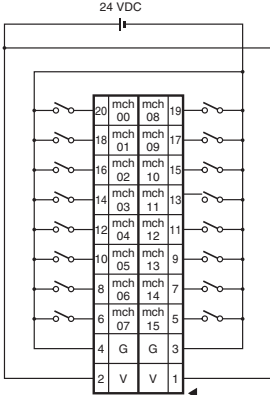

DRT2-ID16ML(X)-1

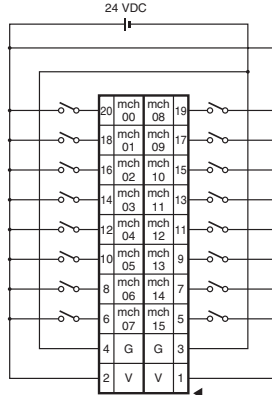

DRT2-OD16ML(X)

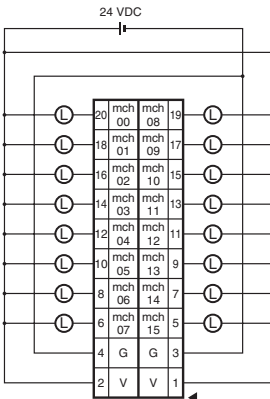

DRT2-OD16ML(X)-1

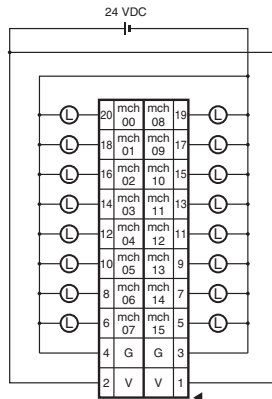

DRT2-ID16MLX(-1)/DRT2-OD16MLX(-1)
Wiring Diagram for Enclosed Cable (with Connectors)

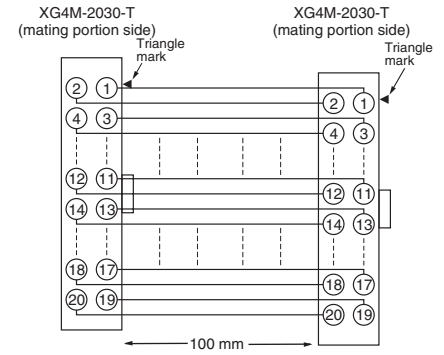

■ Standard Environment-resistive Terminals and Environment-resistive Terminals with Transistors
DRT2-ID04CL (NPN)

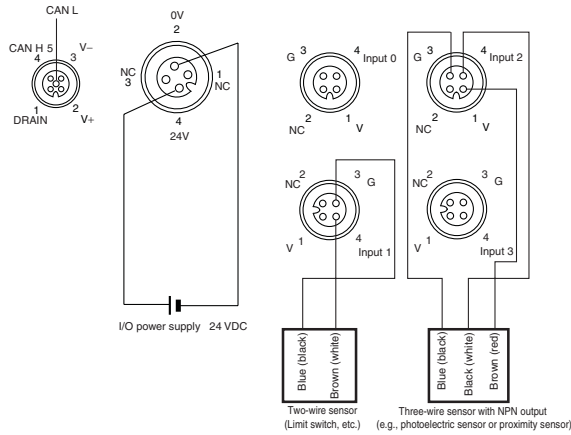

DRT2-ID04CL-1 (PNP)

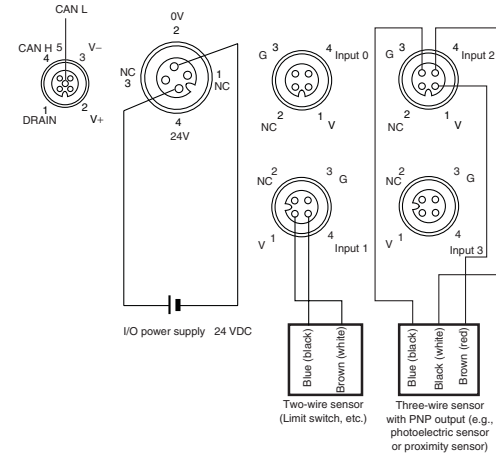

DRT2-OD04CL (NPN)

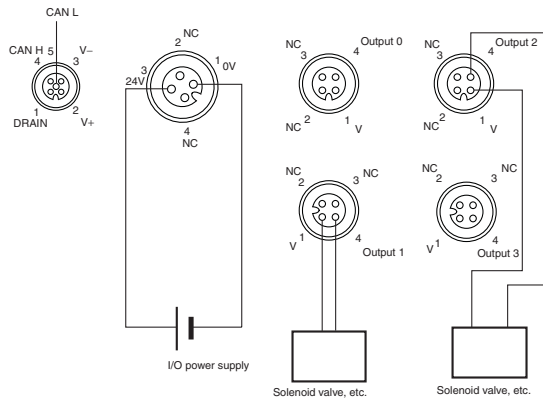

DRT2-OD04CL-1 (PNP)

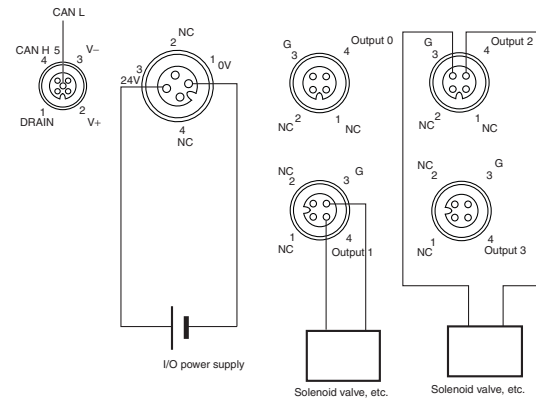

DRT2-ID08CL (NPN)

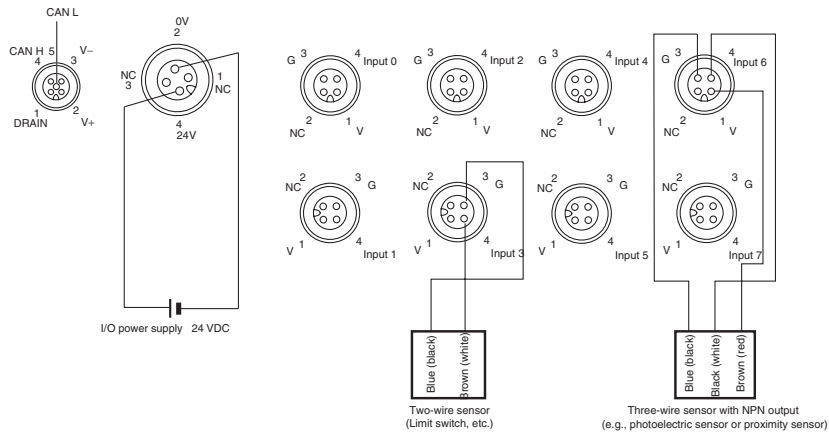

DRT2-ID08CL-1 (PNP)

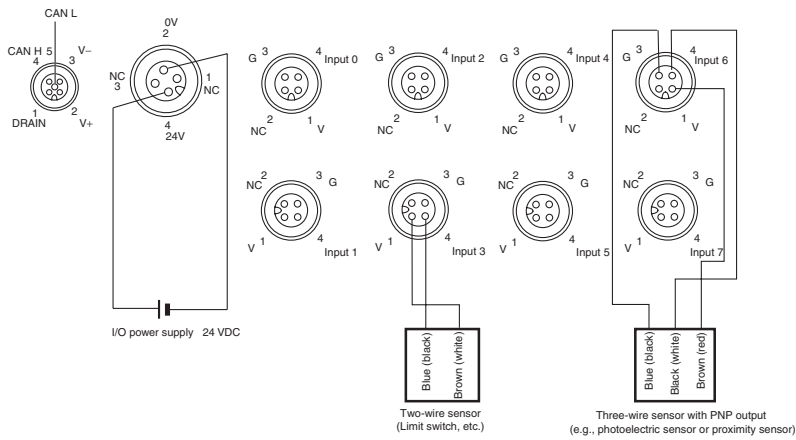

DRT2-OD08CL (NPN)

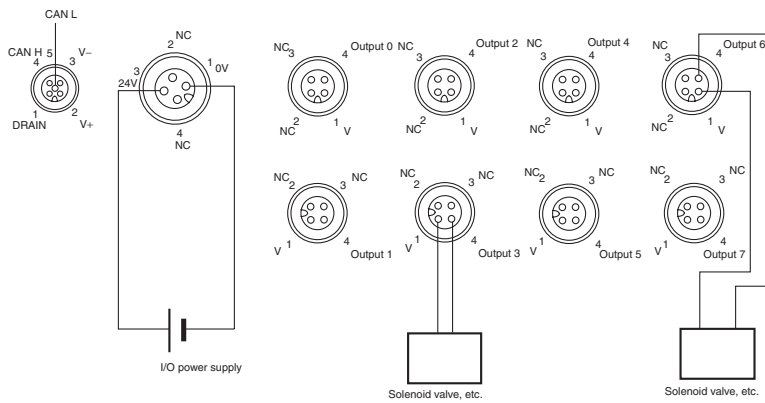

DRT2-OD08CL-1 (PNP)

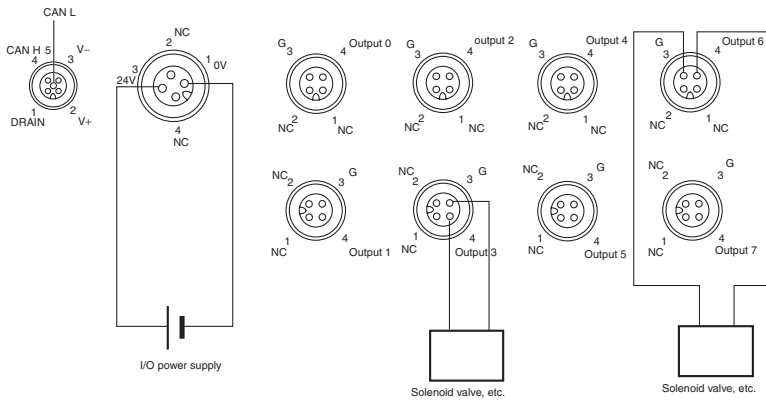

DRT2-HD16CL (NPN)

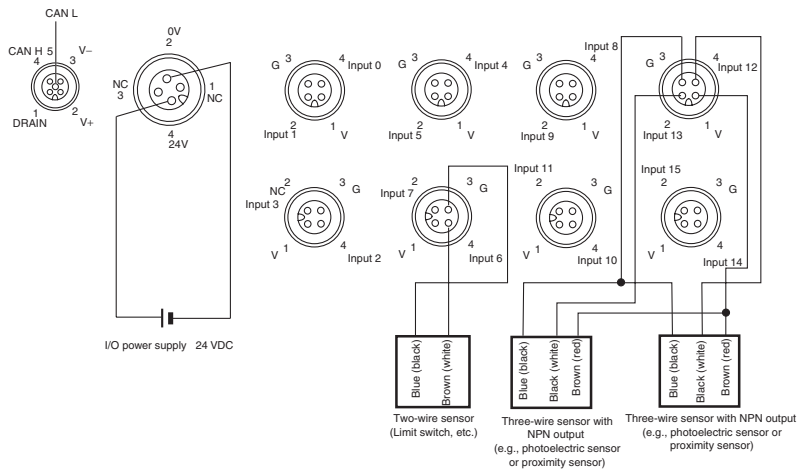

DRT2-HD16CL-1 (PNP)

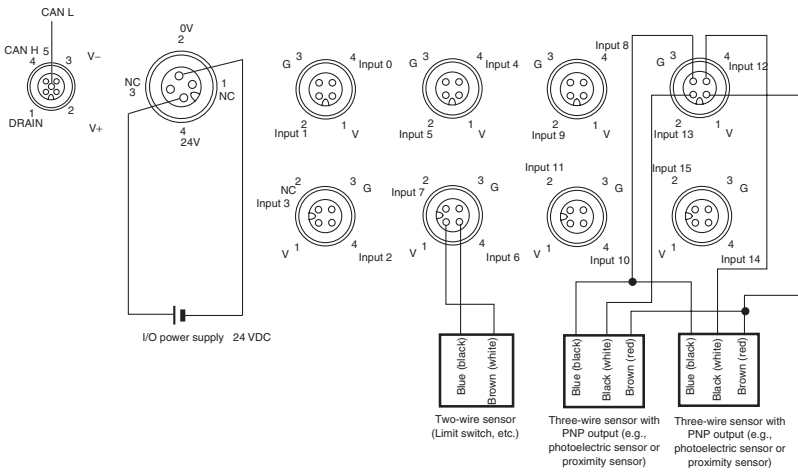

DRT2-WD16CL (NPN)

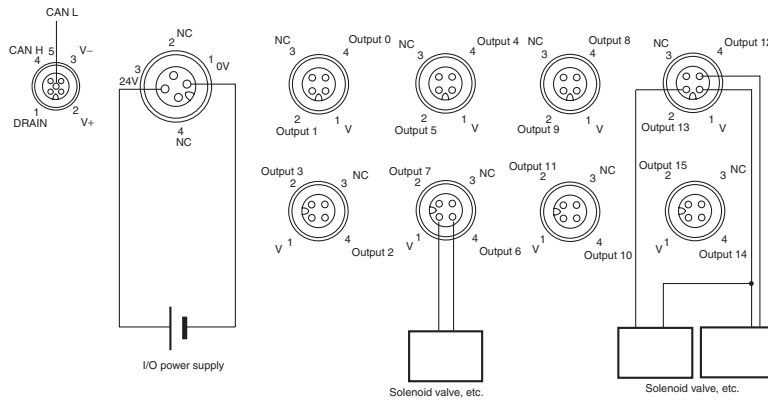

DRT2-WD16CL-1 (PNP)

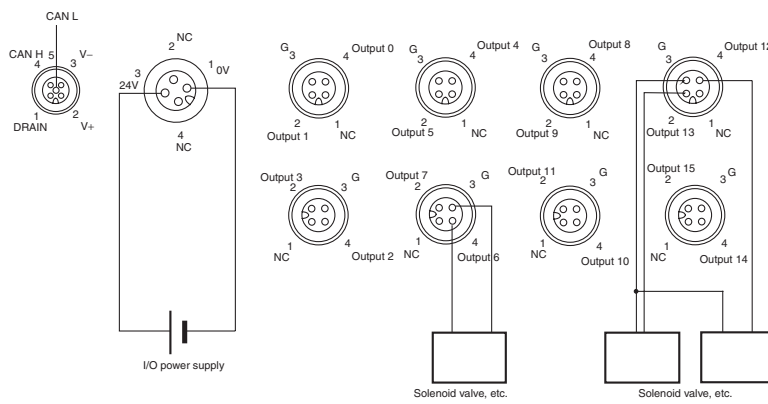

DRT2-MD16CL (NPN)

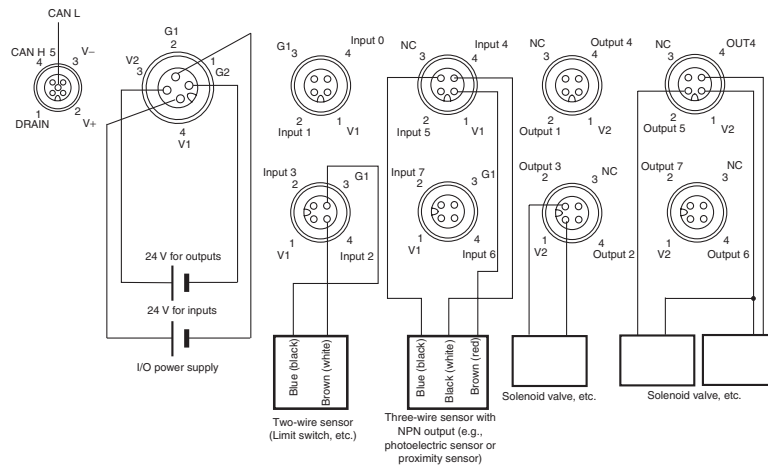

DRT2-MD16CL-1 (PNP)

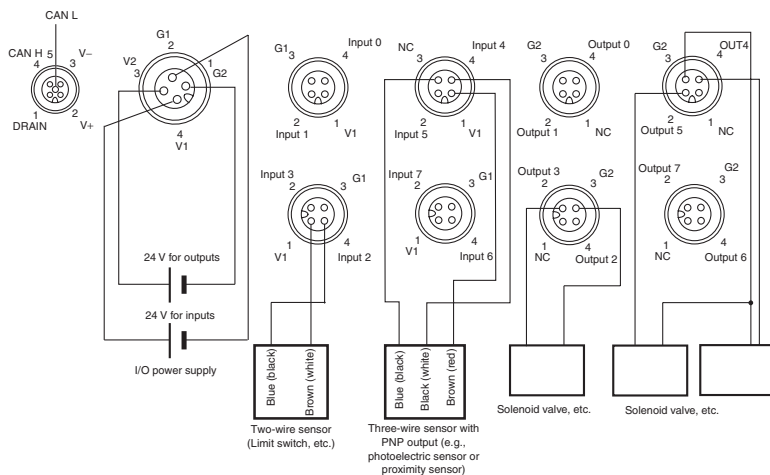

Applicable Cables

■ MIL Connectors with Transistors

● Connector-Terminal Block Conversion Unit and Connecting Cable (16 Points)

Cables with Connectors (1:1)

Model	Applicable cable	Connected Relay Terminal	Remarks
DRT2-ID16ML DRT2-ID16ML-1 DRT2-OD16ML DRT2-OD16ML-1	G79-O□C	XW2D-20G6 XW2B-20G5 XW2B-20G4 XW2C-20G6-IO16	Connector Terminal Block Conversion Unit

● I/O Relay Terminal Connector Cables (16 Points)

Cables with Connectors (1:1)

Model	Applicable cable	Connected Relay Terminal	Remarks
DRT2-ID16ML	G79-I□C	G7TC-ID16 G7TC-IA16	For I/O Relay Terminal inputs
DRT2-ID16ML-1	---	---	(No applicable models)
DRT2-OD16ML	G79-O□C	G7TC-OC16/OC08 G70D-SOC16/VSOC16 G70D-FOM16/VFOM16 G70A-ZOC16-3 G70D-SOC08 G70R-SOC08	For I/O Relay Terminal outputs
DRT2-OD16ML-1	G79-I□C	G7TC-OC16-1	For I/O Relay Terminal outputs
	G79-O□C	G70D-SOC16-1 G70D-FOM16-1 G70A-ZOC16-4	For I/O Relay Terminal outputs

● Cables with Loose Wires with Crimp Terminals





Model	Applicable cable	Remarks
DRT2-ID16ML DRT2-ID16ML-1 DRT2-OD16ML DRT2-OD16ML-1	G79A-Y□C-D1	20-pole connector/ bundled cable (with crimp-style terminals) conversion cable





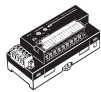
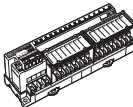

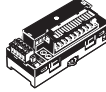
● Cables with Loose Wires

Model	Applicable cable	Remarks
DRT2-ID16ML DRT2-ID16ML-1 DRT2-OD16ML DRT2-OD16ML-1	G79A-A□C-D1	20-pole connector/ bundled cable conversion cable

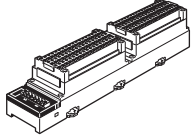
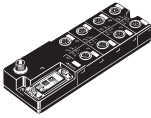

List of Models

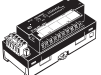
●DRT2-series Smart Slaves

Product name	Shape	Model	Specifications	Approved standards
Remote I/O Basic Terminals with Transistors		DRT2-ID16	16 inputs, NPN (+ common)	UC, CE
		DRT2-ID16-1	16 inputs, PNP (- common)	
		DRT2-OD16	16 outputs, NPN (- common)	
		DRT2-OD16-1	16 outputs, PNP (+ common)	
		DRT2-MD16	8 inputs/8 outputs with NPN, + common for inputs, - common for outputs	
		DRT2-MD16-1	8 inputs/8 outputs with PNP, - common for inputs, + common for outputs	
		DRT2-ID08	8 inputs, NPN (+ common)	
		DRT2-ID08-1	8 inputs, PNP (- common)	
		DRT2-OD08	8 outputs, NPN (- common)	
		DRT2-OD08-1	8 outputs, PNP (+ common)	
Remote I/O Terminal Expansion Units with Transistors		XWT-ID08	8 inputs for terminals with NPN, + common	UC, CE
		XWT-ID08-1	8 inputs for terminals with PNP, - common	
		XWT-OD08	8 outputs for terminals with NPN, - common	
		XWT-OD08-1	8 outputs for terminals with PNP, + common	
		XWT-ID16	16 inputs for terminals with NPN, + common	
		XWT-ID16-1	16 inputs for terminals with PNP, - common	
		XWT-OD16	16 outputs for terminals with NPN, - common	
		XWT-OD16-1	16 outputs for terminals with PNP, + common	
Remote I/O Terminals with 3-tier Terminal Blocks with Transistors		DRT2-ID16TA	16 inputs with NPN, + common	UC, CE
		DRT2-ID16TA-1	16 inputs with PNP, - common	
		DRT2-OD16TA	16 outputs with NPN, - common	
		DRT2-OD16TA-1	16 outputs with PNP, + common	
		DRT2-MD16TA	8 inputs/8 outputs with NPN, + common for inputs, - common for outputs	
DRT2-MD16TA-1	8 inputs/8 outputs with PNP, - common for inputs, + common for outputs			
MIL Connector Terminals with Transistors		DRT2-ID32ML	32 inputs with NPN, + common	UC, CE
		DRT2-ID32ML-1	32 inputs with PNP, - common	
		DRT2-OD32ML	32 outputs with NPN, - common	
		DRT2-OD32ML-1	32 outputs with PNP, + common	
		DRT2-MD32ML	16 inputs/16 outputs with NPN, + common for inputs, - common for outputs	
		DRT2-MD32ML-1	16 inputs/16 outputs with PNP, - common for inputs, + common for outputs	
		DRT2-ID16ML	16 inputs with NPN, + common	
		DRT2-ID16ML-1	16 inputs with PNP, - common	
		DRT2-OD16ML	16 outputs with NPN, - common	
		DRT2-OD16ML-1	16 outputs with PNP, + common	
		DRT2-ID16MLX	16 inputs with NPN, + common, cable with connectors: 10 cm	
		DRT2-ID16MLX-1	16 inputs with PNP, - common, cable with connectors: 10 cm	
		DRT2-OD16MLX	16 outputs with NPN, - common, cable with connectors: 10 cm	
		DRT2-OD16MLX-1	16 outputs with PNP, + common, cable with connectors: 10 cm	
Remote I/O Terminals with Relay Outputs		DRT2-ROS16	16 outputs	UR, CE
Board Terminals with MIL Connectors (horizontal mounting)		DRT2-ID32B	32 inputs, NPN (+ common)	U, CE
		DRT2-ID32B-1	32 inputs, PNP (- common)	
		DRT2-OD32B	32 outputs, NPN (- common)	
		DRT2-OD32B-1	32 outputs, PNP (+ common)	
		DRT2-MD32B	16 inputs/16 outputs, NPN (inputs: + common/outputs: - common)	
		DRT2-MD32B-1	16 inputs/16 outputs, PNP (inputs: - common/outputs: + common)	
Board Terminals with MIL Connectors (vertical mounting)		DRT2-ID32BV	32 inputs, NPN (+ common)	U, CE
		DRT2-ID32BV-1	32 inputs, PNP (- common)	
		DRT2-OD32BV	32 outputs, NPN (- common)	
		DRT2-OD32BV-1	32 outputs, PNP (+ common)	
		DRT2-MD32BV	16 inputs/16 outputs, NPN (inputs: + common/outputs: - common)	
		DRT2-MD32BV-1	16 inputs/16 outputs, PNP (inputs: - common/outputs: + common)	

Product name	Shape	Model	Specifications	Approved standards
Screw-less Clamp Terminals with Transistors		DRT2-ID32SLH	32 inputs, NPN (+ common) with detection functions	UC, CE
		DRT2-ID32SLH-1	32 inputs, PNP (- common) with detection functions	
		DRT2-OD32SLH	32 outputs, NPN (- common) with detection functions	
		DRT2-OD32SLH-1	32 outputs, PNP (+ common) with detection functions	
		DRT2-MD32SLH	16 inputs/16 outputs, NPN (inputs: + common/outputs: - common) with detection functions	
		DRT2-MD32SLH-1	16 inputs/16 outputs, PNP (inputs: - common/outputs: + common) with detection functions	
		DRT2-ID32SL	32 inputs, NPN (+ common) without detection functions	
		DRT2-ID32SL-1	32 inputs, PNP (- common) without detection functions	
		DRT2-OD32SL	32 outputs, NPN (- common) without detection function	
		DRT2-OD32SL-1	32 outputs, PNP (+ common) without detection function	
Environment-resistive Terminals with Transistors		DRT2-ID08C	8 inputs, NPN (+ common) with detection functions	UC, CE
		DRT2-ID08C-1	8 inputs, PNP (- common) with detection functions	
		DRT2-OD08C	8 outputs, NPN (- common) with detection functions	
		DRT2-OD08C-1	8 outputs, PNP (+ common) with detection functions	
		DRT2-HD16C	16 inputs, NPN (+ common) with detection functions	
		DRT2-HD16C-1	16 inputs, PNP (- common) with detection functions	
Environment-resistive Terminals with Transistors		DRT2-ID04CL	4 inputs, NPN (+ common) without detection functions	UC, CE
		DRT2-ID04CL-1	4 inputs, PNP (- common) without detection functions	
		DRT2-OD04CL	4 outputs, NPN (- common) without detection functions	
		DRT2-OD04CL-1	4 outputs, PNP (+ common) without detection functions	
		DRT2-ID08CL	8 inputs, NPN (+ common) without detection functions	UC, CE
		DRT2-ID08CL-1	8 inputs, PNP (- common) without detection functions	
		ADRT2-OD08CL	8 outputs, NPN (- common) without detection functions	
		DRT2-OD08CL-1	8 outputs, PNP (+ common) without detection functions	
		DRT2-HD16CL	16 inputs, NPN (+ common) without detection functions	
		DRT2-HD16CL-1	16 inputs, PNP (- common) without detection functions	
		DRT2-WD16CL	16 outputs, NPN (- common) without detection functions	
		DRT2-WD16CL-1	16 outputs, PNP (+ common) without detection functions	
		DRT2-MD16CL	8 inputs/8 outputs, NPN (inputs: + common/outputs: - common) without detection function	
		DRT2-MD16CL-1	8 inputs/8 outputs, PNP (inputs: - common/outputs: + common) without detection function	
e-con Connector Terminals		DRT2-ID16S	16 inputs, NPN (+ common)	UC, CE
		DRT2-ID16S-1	16 inputs, PNP (- common)	
		DRT2-MD16S	8 inputs/8 outputs, NPN (inputs: + common/outputs: - common)	
		DRT2-MD16S-1	8 inputs/8 outputs, PNP (inputs: - common/outputs: + common)	
Analog Input Terminals		DRT2-AD04	4 inputs (resolution: 6,000)	UC, CE
DRT2-AD04H		4 inputs (resolution: 30,000)		
Analog Output Terminals		DRT2-DA02	2 outputs	
Temperature Input Terminals with Thermocouple Inputs		DRT2-TS04T	4 inputs	U, CE
Temperature Input Terminals with Resistance-thermometer Inputs		DRT2-TS04P	4 inputs	

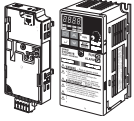
● Intelligent Slaves

Product name	Shape	Model	Specifications	Approved standards
Modular Temperature Controllers		E5ZN-DRT	DeviceNet Communications Unit for E5ZN	---
		E5ZN-SCT24S	Terminal Unit	
	---	E5ZN-SDL	Setting Display Unit	
Multi-function Compact Inverter		3G3MV-PDRT2	Communications Unit for 3G3MV Inverters	U, CE
High-function General-purpose Inverters		3G3RV-PDRT2	3G3RV/3G3FV DeviceNet Communications Card	U, CE

Terms and Conditions of Sale

- Offer; Acceptance.** These terms and conditions (these "Terms") are deemed part of all quotes, agreements, purchase orders, acknowledgments, price lists, catalogs, manuals, brochures and other documents, whether electronic or in writing, relating to the sale of products or services (collectively, the "Products") by Omron Electronics LLC and its subsidiary companies ("Omron"). Omron objects to any terms or conditions proposed in Buyer's purchase order or other documents which are inconsistent with, or in addition to, these Terms.
- Prices; Payment Terms.** All prices stated are current, subject to change without notice by Omron. Omron reserves the right to increase or decrease prices on any unshipped portions of outstanding orders. Payments for Products are due net 30 days unless otherwise stated in the invoice.
- Discounts.** Cash discounts, if any, will apply only on the net amount of invoices sent to Buyer after deducting transportation charges, taxes and duties, and will be allowed only if (i) the invoice is paid according to Omron's payment terms and (ii) Buyer has no past due amounts.
- Interest.** Omron, at its option, may charge Buyer 1-1/2% interest per month or the maximum legal rate, whichever is less, on any balance not paid within the stated terms.
- Orders.** Omron will accept no order less than \$200 net billing.
- Governmental Approvals.** Buyer shall be responsible for, and shall bear all costs involved in, obtaining any government approvals required for the importation or sale of the Products.
- Taxes.** All taxes, duties and other governmental charges (other than general real property and income taxes), including any interest or penalties thereon, imposed directly or indirectly on Omron or required to be collected directly or indirectly by Omron for the manufacture, production, sale, delivery, importation, consumption or use of the Products sold hereunder (including customs duties and sales, excise, use, turnover and license taxes) shall be charged to and remitted by Buyer to Omron.
- Financial.** If the financial position of Buyer at any time becomes unsatisfactory to Omron, Omron reserves the right to stop shipments or require satisfactory security or payment in advance. If Buyer fails to make payment or otherwise comply with these Terms or any related agreement, Omron may (without liability and in addition to other remedies) cancel any unshipped portion of Products sold hereunder and stop any Products in transit until Buyer pays all amounts, including amounts payable hereunder, whether or not then due, which are owing to it by Buyer. Buyer shall in any event remain liable for all unpaid accounts.
- Cancellation; Etc.** Orders are not subject to rescheduling or cancellation unless Buyer indemnifies Omron against all related costs or expenses.
- Force Majeure.** Omron shall not be liable for any delay or failure in delivery resulting from causes beyond its control, including earthquakes, fires, floods, strikes or other labor disputes, shortage of labor or materials, accidents to machinery, acts of sabotage, riots, delay in or lack of transportation or the requirements of any government authority.
- Shipping; Delivery.** Unless otherwise expressly agreed in writing by Omron:
 - Shipments shall be by a carrier selected by Omron; Omron will not drop ship except in "break down" situations.
 - Such carrier shall act as the agent of Buyer and delivery to such carrier shall constitute delivery to Buyer;
 - All sales and shipments of Products shall be FOB shipping point (unless otherwise stated in writing by Omron), at which point title and risk of loss shall pass from Omron to Buyer; provided that Omron shall retain a security interest in the Products until the full purchase price is paid;
 - Delivery and shipping dates are estimates only; and
 - Omron will package Products as it deems proper for protection against normal handling and extra charges apply to special conditions.
- Claims.** Any claim by Buyer against Omron for shortage or damage to the Products occurring before delivery to the carrier must be presented in writing to Omron within 30 days of receipt of shipment and include the original transportation bill signed by the carrier noting that the carrier received the Products from Omron in the condition claimed.
- Warranties.** (a) **Exclusive Warranty.** Omron's exclusive warranty is that the Products will be free from defects in materials and workmanship for a period of twelve months from the date of sale by Omron (or such other period expressed in writing by Omron). Omron disclaims all other warranties, express or implied. (b) **Limitations.** OMRON MAKES NO WARRANTY OR REPRESENTATION, EXPRESS OR IMPLIED, ABOUT NON-INFRINGEMENT, MERCHANTABILITY OR FITNESS FOR A PARTICULAR PURPOSE OF THE PRODUCTS. BUYER ACKNOWLEDGES THAT IT ALONE HAS DETERMINED THAT THE PRODUCTS WILL SUITABLY MEET THE REQUIREMENTS OF THEIR INTENDED USE. Omron further disclaims all warranties and responsibility of any type for claims or expenses based on infringement by the Products or otherwise of any intellectual property right. (c) **Buyer Remedy.** Omron's sole obligation hereunder shall be, at Omron's election, to (i) replace (in the form originally shipped with Buyer responsible for labor charges for removal or replacement thereof) the non-complying Product, (ii) repair the non-complying Product, or (iii) repay or credit Buyer an amount equal to the purchase price of the non-complying Product; provided that in no event shall Omron be responsible for warranty, repair, indemnity or any other claims or expenses regarding the Products unless Omron's analysis confirms that the Products were properly handled, stored, installed and maintained and not subject to contamination, abuse, misuse or inappropriate modification. Return of any Products by Buyer must be approved in writing by Omron before shipment. Omron Companies shall not be liable for the suitability or unsuitability or the results from the use of Products in combination with any electrical or electronic components, circuits, system assemblies or any other materials or substances or environments. Any advice, recommendations or information given orally or in writing, are not to be construed as an amendment or addition to the above warranty. See <http://oeweb.omron.com> or contact your Omron representative for published information.
- Limitation on Liability; Etc.** OMRON COMPANIES SHALL NOT BE LIABLE FOR SPECIAL, INDIRECT, INCIDENTAL, OR CONSEQUENTIAL DAMAGES, LOSS OF PROFITS OR PRODUCTION OR COMMERCIAL LOSS IN ANY WAY CONNECTED WITH THE PRODUCTS, WHETHER SUCH CLAIM IS BASED IN CONTRACT, WARRANTY, NEGLIGENCE OR STRICT LIABILITY. Further, in no event shall liability of Omron Companies exceed the individual price of the Product on which liability is asserted.
- Indemnities.** Buyer shall indemnify and hold harmless Omron Companies and their employees from and against all liabilities, losses, claims, costs and expenses (including attorney's fees and expenses) related to any claim, investigation, litigation or proceeding (whether or not Omron is a party) which arises or is alleged to arise from Buyer's acts or omissions under these Terms or in any way with respect to the Products. Without limiting the foregoing, Buyer (at its own expense) shall indemnify and hold harmless Omron and defend or settle any action brought against such Companies to the extent based on a claim that any Product made to Buyer specifications infringed intellectual property rights of another party.
- Property; Confidentiality.** Any intellectual property in the Products is the exclusive property of Omron Companies and Buyer shall not attempt to duplicate it in any way without the written permission of Omron. Notwithstanding any charges to Buyer for engineering or tooling, all engineering and tooling shall remain the exclusive property of Omron. All information and materials supplied by Omron to Buyer relating to the Products are confidential and proprietary, and Buyer shall limit distribution thereof to its trusted employees and strictly prevent disclosure to any third party.
- Export Controls.** Buyer shall comply with all applicable laws, regulations and licenses regarding (i) export of products or information; (ii) sale of products to "forbidden" or other proscribed persons; and (iii) disclosure to non-citizens of regulated technology or information.
- Miscellaneous.** (a) **Waiver.** No failure or delay by Omron in exercising any right and no course of dealing between Buyer and Omron shall operate as a waiver of rights by Omron. (b) **Assignment.** Buyer may not assign its rights hereunder without Omron's written consent. (c) **Law.** These Terms are governed by the law of the jurisdiction of the home office of the Omron company from which Buyer is purchasing the Products (without regard to conflict of law principles). (d) **Amendment.** These Terms constitute the entire agreement between Buyer and Omron relating to the Products, and no provision may be changed or waived unless in writing signed by the parties. (e) **Severability.** If any provision hereof is rendered ineffective or invalid, such provision shall not invalidate any other provision. (f) **Setoff.** Buyer shall have no right to set off any amounts against the amount owing in respect of this invoice. (g) **Definitions.** As used herein, "including" means "including without limitation"; and "Omron Companies" (or similar words) mean Omron Corporation and any direct or indirect subsidiary or affiliate thereof.

Certain Precautions on Specifications and Use

- Suitability of Use.** Omron Companies shall not be responsible for conformity with any standards, codes or regulations which apply to the combination of the Product in the Buyer's application or use of the Product. At Buyer's request, Omron will provide applicable third party certification documents identifying ratings and limitations of use which apply to the Product. This information by itself is not sufficient for a complete determination of the suitability of the Product in combination with the end product, machine, system, or other application or use. Buyer shall be solely responsible for determining appropriateness of the particular Product with respect to Buyer's application, product or system. Buyer shall take application responsibility in all cases but the following is a non-exhaustive list of applications for which particular attention must be given:
 - Outdoor use, uses involving potential chemical contamination or electrical interference, or conditions or uses not described in this document.
 - Use in consumer products or any use in significant quantities.
 - Energy control systems, combustion systems, railroad systems, aviation systems, medical equipment, amusement machines, vehicles, safety equipment, and installations subject to separate industry or government regulations.
 - Systems, machines and equipment that could present a risk to life or property. Please know and observe all prohibitions of use applicable to this Product.

NEVER USE THE PRODUCT FOR AN APPLICATION INVOLVING SERIOUS RISK TO LIFE OR PROPERTY OR IN LARGE QUANTITIES WITHOUT ENSURING THAT THE SYSTEM AS A WHOLE HAS BEEN DESIGNED TO ADDRESS THE RISKS, AND THAT THE OMRON'S PRODUCT IS PROPERLY RATED AND INSTALLED FOR THE INTENDED USE WITHIN THE OVERALL EQUIPMENT OR SYSTEM.
- Programmable Products.** Omron Companies shall not be responsible for the user's programming of a programmable Product, or any consequence thereof.
- Performance Data.** Data presented in Omron Company websites, catalogs and other materials is provided as a guide for the user in determining suitability and does not constitute a warranty. It may represent the result of Omron's test conditions, and the user must correlate it to actual application requirements. Actual performance is subject to the Omron's Warranty and Limitations of Liability.
- Change in Specifications.** Product specifications and accessories may be changed at any time based on improvements and other reasons. It is our practice to change part numbers when published ratings or features are changed, or when significant construction changes are made. However, some specifications of the Product may be changed without any notice. When in doubt, special part numbers may be assigned to fix or establish key specifications for your application. Please consult with your Omron's representative at any time to confirm actual specifications of purchased Product.
- Errors and Omissions.** Information presented by Omron Companies has been checked and is believed to be accurate; however, no responsibility is assumed for clerical, typographical or proofreading errors or omissions.

Terms and Conditions of Sale

- Offer; Acceptance.** These terms and conditions (these "Terms") are deemed part of all quotes, agreements, purchase orders, acknowledgments, price lists, catalogs, manuals, brochures and other documents, whether electronic or in writing, relating to the sale of products or services (collectively, the "Products") by Omron Electronics LLC and its subsidiary companies ("Omron"). Omron objects to any terms or conditions proposed in Buyer's purchase order or other documents which are inconsistent with, or in addition to, these Terms.
- Prices; Payment Terms.** All prices stated are current, subject to change without notice by Omron. Omron reserves the right to increase or decrease prices on any unshipped portions of outstanding orders. Payments for Products are due net 30 days unless otherwise stated in the invoice.
- Discounts.** Cash discounts, if any, will apply only on the net amount of invoices sent to Buyer after deducting transportation charges, taxes and duties, and will be allowed only if (i) the invoice is paid according to Omron's payment terms and (ii) Buyer has no past due amounts.
- Interest.** Omron, at its option, may charge Buyer 1-1/2% interest per month or the maximum legal rate, whichever is less, on any balance not paid within the stated terms.
- Orders.** Omron will accept no order less than \$200 net billing.
- Governmental Approvals.** Buyer shall be responsible for, and shall bear all costs involved in, obtaining any government approvals required for the importation or sale of the Products.
- Taxes.** All taxes, duties and other governmental charges (other than general real property and income taxes), including any interest or penalties thereon, imposed directly or indirectly on Omron or required to be collected directly or indirectly by Omron for the manufacture, production, sale, delivery, importation, consumption or use of the Products sold hereunder (including customs duties and sales, excise, use, turnover and license taxes) shall be charged to and remitted by Buyer to Omron.
- Financial.** If the financial position of Buyer at any time becomes unsatisfactory to Omron, Omron reserves the right to stop shipments or require satisfactory security or payment in advance. If Buyer fails to make payment or otherwise comply with these Terms or any related agreement, Omron may (without liability and in addition to other remedies) cancel any unshipped portion of Products sold hereunder and stop any Products in transit until Buyer pays all amounts, including amounts payable hereunder, whether or not then due, which are owing to it by Buyer. Buyer shall in any event remain liable for all unpaid accounts.
- Cancellation; Etc.** Orders are not subject to rescheduling or cancellation unless Buyer indemnifies Omron against all related costs or expenses.
- Force Majeure.** Omron shall not be liable for any delay or failure in delivery resulting from causes beyond its control, including earthquakes, fires, floods, strikes or other labor disputes, shortage of labor or materials, accidents to machinery, acts of sabotage, riots, delay in or lack of transportation or the requirements of any government authority.
- Shipping; Delivery.** Unless otherwise expressly agreed in writing by Omron:
 - Shipments shall be by a carrier selected by Omron; Omron will not drop ship except in "break down" situations.
 - Such carrier shall act as the agent of Buyer and delivery to such carrier shall constitute delivery to Buyer;
 - All sales and shipments of Products shall be FOB shipping point (unless otherwise stated in writing by Omron), at which point title and risk of loss shall pass from Omron to Buyer; provided that Omron shall retain a security interest in the Products until the full purchase price is paid;
 - Delivery and shipping dates are estimates only; and
 - Omron will package Products as it deems proper for protection against normal handling and extra charges apply to special conditions.
- Claims.** Any claim by Buyer against Omron for shortage or damage to the Products occurring before delivery to the carrier must be presented in writing to Omron within 30 days of receipt of shipment and include the original transportation bill signed by the carrier noting that the carrier received the Products from Omron in the condition claimed.
- Warranties.** (a) **Exclusive Warranty.** Omron's exclusive warranty is that the Products will be free from defects in materials and workmanship for a period of twelve months from the date of sale by Omron (or such other period expressed in writing by Omron). Omron disclaims all other warranties, express or implied. (b) **Limitations.** OMRON MAKES NO WARRANTY OR REPRESENTATION, EXPRESS OR IMPLIED, ABOUT NON-INFRINGEMENT, MERCHANTABILITY OR FITNESS FOR A PARTICULAR PURPOSE OF THE PRODUCTS. BUYER ACKNOWLEDGES THAT IT ALONE HAS DETERMINED THAT THE PRODUCTS WILL SUITABLY MEET THE REQUIREMENTS OF THEIR INTENDED USE. Omron further disclaims all warranties and responsibility of any type for claims or expenses based on infringement by the Products or otherwise of any intellectual property right. (c) **Buyer Remedy.** Omron's sole obligation hereunder shall be, at Omron's election, to (i) replace (in the form originally shipped with Buyer responsible for labor charges for removal or replacement thereof) the non-complying Product, (ii) repair the non-complying Product, or (iii) repay or credit Buyer an amount equal to the purchase price of the non-complying Product; provided that in no event shall Omron be responsible for warranty, repair, indemnity or any other claims or expenses regarding the Products unless Omron's analysis confirms that the Products were properly handled, stored, installed and maintained and not subject to contamination, abuse, misuse or inappropriate modification. Return of any Products by Buyer must be approved in writing by Omron before shipment. Omron Companies shall not be liable for the suitability or unsuitability or the results from the use of Products in combination with any electrical or electronic components, circuits, system assemblies or any other materials or substances or environments. Any advice, recommendations or information given orally or in writing, are not to be construed as an amendment or addition to the above warranty. See <http://www.omron247.com> or contact your Omron representative for published information.
- Limitation on Liability; Etc.** OMRON COMPANIES SHALL NOT BE LIABLE FOR SPECIAL, INDIRECT, INCIDENTAL, OR CONSEQUENTIAL DAMAGES, LOSS OF PROFITS OR PRODUCTION OR COMMERCIAL LOSS IN ANY WAY CONNECTED WITH THE PRODUCTS, WHETHER SUCH CLAIM IS BASED IN CONTRACT, WARRANTY, NEGLIGENCE OR STRICT LIABILITY. Further, in no event shall liability of Omron Companies exceed the individual price of the Product on which liability is asserted.
- Indemnities.** Buyer shall indemnify and hold harmless Omron Companies and their employees from and against all liabilities, losses, claims, costs and expenses (including attorney's fees and expenses) related to any claim, investigation, litigation or proceeding (whether or not Omron is a party) which arises or is alleged to arise from Buyer's acts or omissions under these Terms or in any way with respect to the Products. Without limiting the foregoing, Buyer (at its own expense) shall indemnify and hold harmless Omron and defend or settle any action brought against such Companies to the extent based on a claim that any Product made to Buyer specifications infringed intellectual property rights of another party.
- Property; Confidentiality.** Any intellectual property in the Products is the exclusive property of Omron Companies and Buyer shall not attempt to duplicate it in any way without the written permission of Omron. Notwithstanding any charges to Buyer for engineering or tooling, all engineering and tooling shall remain the exclusive property of Omron. All information and materials supplied by Omron to Buyer relating to the Products are confidential and proprietary, and Buyer shall limit distribution thereof to its trusted employees and strictly prevent disclosure to any third party.
- Export Controls.** Buyer shall comply with all applicable laws, regulations and licenses regarding (i) export of products or information; (ii) sale of products to "forbidden" or other proscribed persons; and (iii) disclosure to non-citizens of regulated technology or information.
- Miscellaneous.** (a) **Waiver.** No failure or delay by Omron in exercising any right and no course of dealing between Buyer and Omron shall operate as a waiver of rights by Omron. (b) **Assignment.** Buyer may not assign its rights hereunder without Omron's written consent. (c) **Law.** These Terms are governed by the law of the jurisdiction of the home office of the Omron company from which Buyer is purchasing the Products (without regard to conflict of law principles). (d) **Amendment.** These Terms constitute the entire agreement between Buyer and Omron relating to the Products, and no provision may be changed or waived unless in writing signed by the parties. (e) **Severability.** If any provision hereof is rendered ineffective or invalid, such provision shall not invalidate any other provision. (f) **Setoff.** Buyer shall have no right to set off any amounts against the amount owing in respect of this invoice. (g) **Definitions.** As used herein, "including" means "including without limitation"; and "Omron Companies" (or similar words) mean Omron Corporation and any direct or indirect subsidiary or affiliate thereof.

Certain Precautions on Specifications and Use

- Suitability of Use.** Omron Companies shall not be responsible for conformity with any standards, codes or regulations which apply to the combination of the Product in the Buyer's application or use of the Product. At Buyer's request, Omron will provide applicable third party certification documents identifying ratings and limitations of use which apply to the Product. This information by itself is not sufficient for a complete determination of the suitability of the Product in combination with the end product, machine, system, or other application or use. Buyer shall be solely responsible for determining appropriateness of the particular Product with respect to Buyer's application, product or system. Buyer shall take application responsibility in all cases but the following is a non-exhaustive list of applications for which particular attention must be given:
 - Outdoor use, uses involving potential chemical contamination or electrical interference, or conditions or uses not described in this document.
 - Use in consumer products or any use in significant quantities.
 - Energy control systems, combustion systems, railroad systems, aviation systems, medical equipment, amusement machines, vehicles, safety equipment, and installations subject to separate industry or government regulations.
 - Systems, machines and equipment that could present a risk to life or property. Please know and observe all prohibitions of use applicable to this Product.

NEVER USE THE PRODUCT FOR AN APPLICATION INVOLVING SERIOUS RISK TO LIFE OR PROPERTY OR IN LARGE QUANTITIES WITHOUT ENSURING THAT THE SYSTEM AS A WHOLE HAS BEEN DESIGNED TO ADDRESS THE RISKS, AND THAT THE OMRON'S PRODUCT IS PROPERLY RATED AND INSTALLED FOR THE INTENDED USE WITHIN THE OVERALL EQUIPMENT OR SYSTEM.
- Programmable Products.** Omron Companies shall not be responsible for the user's programming of a programmable Product, or any consequence thereof.
- Performance Data.** Data presented in Omron Company websites, catalogs and other materials is provided as a guide for the user in determining suitability and does not constitute a warranty. It may represent the result of Omron's test conditions, and the user must correlate it to actual application requirements. Actual performance is subject to the Omron's Warranty and Limitations of Liability.
- Change in Specifications.** Product specifications and accessories may be changed at any time based on improvements and other reasons. It is our practice to change part numbers when published ratings or features are changed, or when significant construction changes are made. However, some specifications of the Product may be changed without any notice. When in doubt, special part numbers may be assigned to fix or establish key specifications for your application. Please consult with your Omron's representative at any time to confirm actual specifications of purchased Product.
- Errors and Omissions.** Information presented by Omron Companies has been checked and is believed to be accurate; however, no responsibility is assumed for clerical, typographical or proofreading errors or omissions.

Note: This datasheet is provided as a guideline for selecting products. Do not use this document to operate the Unit.

ALL DIMENSIONS SHOWN ARE IN MILLIMETERS.

To convert millimeters into inches, multiply by 0.03937. To convert grams into ounces, multiply by 0.03527.

OMRON

OMRON ELECTRONICS LLC • THE AMERICAS HEADQUARTERS

Schaumburg, IL USA • 847.843.7900 • 800.556.6766 • www.omron247.com

OMRON CANADA, INC. • HEAD OFFICE

Toronto, ON, Canada • 416.286.6465 • 866.986.6766 • www.omron247.com

OMRON ELETRÔNICA DO BRASIL LTDA • HEAD OFFICE

São Paulo, SP, Brasil • 55.11.2101.6300 • www.omron.com.br

OMRON ELECTRONICS MEXICO SA DE CV • HEAD OFFICE

Apodaca, N.L. • 52.811.156.99.10 • 001.800.556.6766 • mela@omron.com

OMRON ARGENTINA • SALES OFFICE

Cono Sur • 54.11.4783.5300

OMRON CHILE • SALES OFFICE

Santiago • 56.9.9917.3920

OTHER OMRON LATIN AMERICA SALES

54.11.4783.5300

© 2009 Omron Electronics LLC