

NEW

Anti-Sulfurated Chip Resistor Array

Type: **EXBU2 : 0402 Array**
EXBU3 : 0603 Array



■ **Features**

- High resistance to sulfurization achieved by adopting an Ag-Pb-based inner electrode
- High density
 - 2 resistors in 1.0 mm × 1.0 mm size (EXBU24)
 - 4 resistors in 2.0 mm × 1.0 mm size (EXBU28)
 - 8 resistors in 3.8 mm × 1.6 mm size (EXBU2H)
 - 2 resistors in 1.6 mm × 1.6 mm size (EXBU34)
 - 4 resistors in 3.2 mm × 1.6 mm size (EXBU38)
- Improvement of placement efficiency
 Placement efficiency of Chip Resistor Array is two, four or eight times of the flat type chip resistor
- Reference Standard: IEC 60115-9, JIS C 5201-9, EIAJ RC-2129
- RoHS compliant

■ **Packaging Methods, Land Pattern, Soldering Conditions and Safety Precautions**

Please see Data Files

■ **Explanation of Part Numbers**

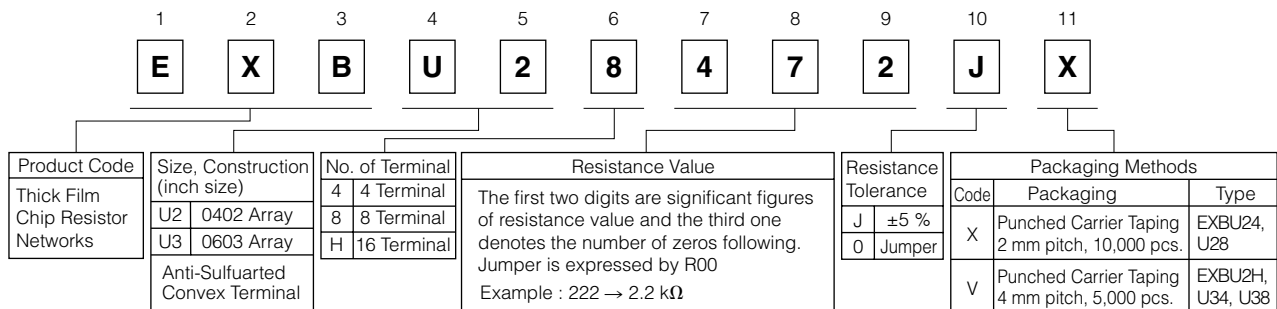

■ **Construction**

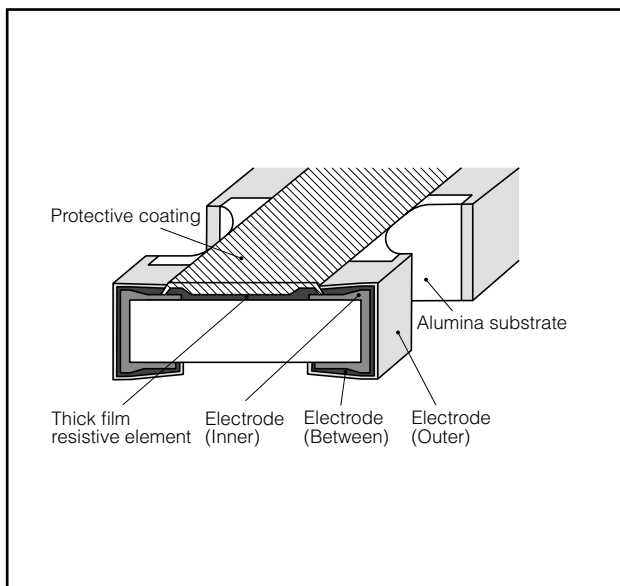

■ **Schematics**

- Isolated type

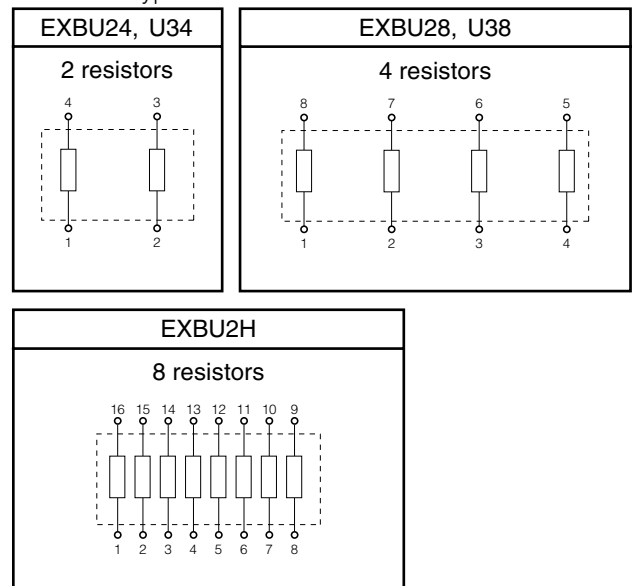

Design and specifications are each subject to change without notice. Ask factory for the current technical specifications before purchase and/or use. Should a safety concern arise regarding this product, please be sure to contact us immediately.

■ Dimensions in mm (not to scale)

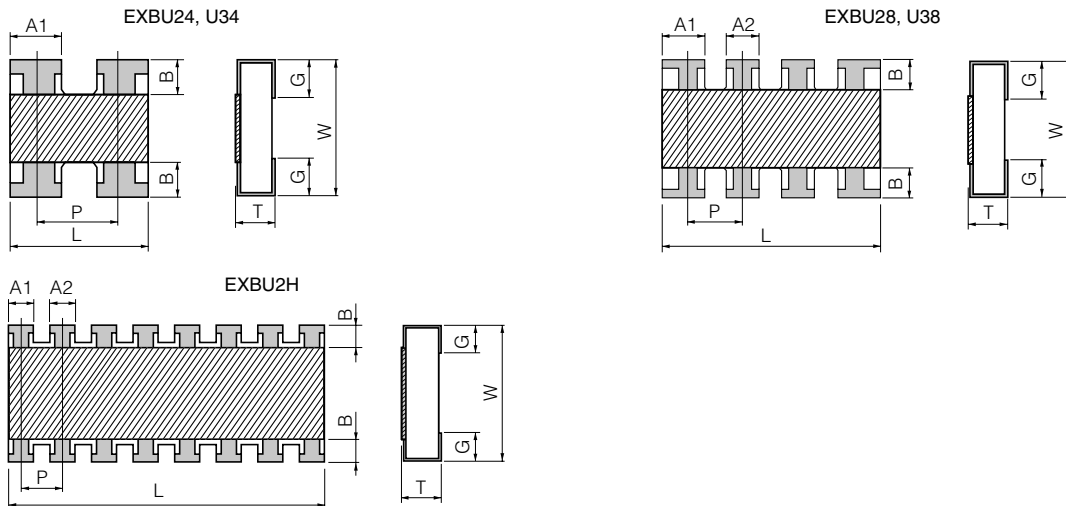

Type (inch size)	Dimensions (mm)								Mass (Weight) [g/1000 pcs.]
	L	W	T	A1	A2	B	P	G	
EXBU24 (0402×2)	1.00±0.10	1.00±0.10	0.35±0.10	0.40±0.10	—	0.18±0.10	(0.65)	0.25±0.10	1.2
EXBU28 (0402×4)	2.00±0.10	1.00±0.10	0.35±0.10	0.45±0.10	0.35±0.10	0.20±0.10	(0.50)	0.25±0.10	2.0
EXBU2H (0402×8)	3.80±0.10	1.60±0.10	0.45±0.10	0.35±0.10	0.35±0.10	0.30±0.10	(0.50)	0.30±0.10	9.0
EXBU34 (0603×2)	1.60±0.20	1.60±0.15	0.50±0.10	0.65±0.15	—	0.30±0.20	(0.80)	0.30±0.20	3.5
EXBU38 (0603×4)	3.20±0.20	1.60±0.15	0.50±0.10	0.65±0.15	0.45±0.15	0.30±0.20	(0.80)	0.35±0.20	7.0

() Reference

■ Ratings

Item		Specifications
Resistance Range		10 Ω to 1 MΩ E24 series
Resistance Tolerance		J: ±5 %
Number of Terminals	U24, U34	4 terminal
	U28, U38	8 terminal
	U2H	16 element
Number of Resistors	U24, U34	2 element
	U28, U38	4 element
	U2H	8 element
Power Rating at 70 °C	U24, U28, U34, U38	0.063 W/element
	U2H	0.063 W/element (0.25 W/package)

Item		Specifications
Limiting Element Voltage ⁽¹⁾	U2H	25 V
	U24, U28, U34, U38	50 V
Max. Overload Voltage ⁽²⁾	U2H	50 V
	U24, U28, U34, U38	100 V
T.C.R.		±200×10 ⁻⁶ /°C
Category Temperature Range		-55 °C to 125 °C
Jumper Array	Rated Current	U24, U28, U2H, U34, U38 1 A
	Max. Overload Current	U24, U28, U2H, U34, U38 2 A

(1) Rated Continuous Working Voltage (RCWV) shall be determined from $RCWV = \sqrt{\text{Power Rating} \times \text{Resistance Value}}$, or Limiting Element Voltage listed above, whichever less.

(2) Overload (Short-time Overload) Test Voltage (SOTV) shall be determined from $SOTV = 2.5 \times \text{Power Rating}$ or max. Overload Voltage listed above whichever less.

Power Derating Curve

For resistors operated in ambient temperature above 70 °C, power rating shall be derated in accordance with the figure on the right.

