

THIS COPY IS PROVIDED ON A RESTRICTED BASIS AND IS NOT TO BE USED IN ANY WAY DETRIMENTAL TO THE INTERESTS OF PANDUIT CORP.

PANDUIT P/N	WEIGHT
CHS2S	1.7 LB/100 PCS (750g/100 PCS)

LOCKING TABS FOR  
MINI-COM MODULES.

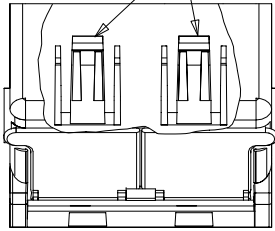

NOTES:

- SEE CURRENT CATALOG FOR ADDITIONAL PART NUMBER SUFFIXES TO INDICATE COLOR AND OR PACKAGE QUANTITY.
- THIS PART IS TO BE USED WITH THE MINI-COM BEZELS AND MINI-COM MODULES.
- DIMENSIONS IN PARENTHESES ARE IN METRIC.

SHUTTERS

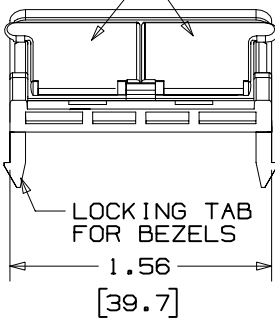

WALL THICKNESS .093  
(2.4)

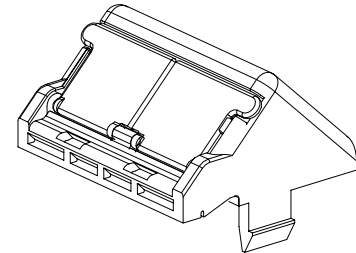
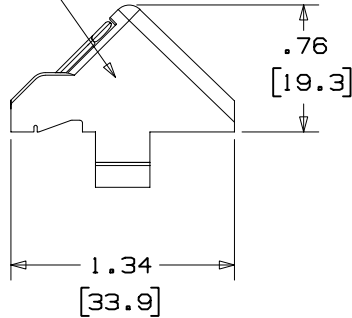

CAD FILENAME/LAYERS		D35544BD_CHS2S_02.PRT					
<h1>PANDUIT</h1> CORP. TINLEY PARK, ILLINOIS		1/2 SIZE SLOPED SHUTTERED MODULE INSERT (NON-SHUTTERED ALSO AVAILABLE (CHS2S))					
		CUSTOMER DRAWING					
UNLESS OTHERWISE SPECIFIED, DIMENSIONAL TOLERANCES ARE: (.X) ± (.XXX) ±.010(.3) (.XX) ±.03(.8) ANGLES ±		UNLESS OTHERWISE SPECIFIED, ALL DIMENSIONS ARE GIVEN IN INCHES, THIRD ANGLE PROJECTION.					
2	3-12-98	JBA	B. REV'D P/N IN TITLE: WAS CH2S2.				
1	9-12-97	RCA	CEF	A. REV'D TITLE WAS TWO MODULE MINI-COM SLOPED INSERT W/ PROTECTIVE SHUTTERS FOR EXEC. BEZELS.			
R	3-29-96	DW	CEF	RELEASED TO PRODUCTION.			
REV	DATE	BY	CHK	DESCRIPTION			
				ECN	CHK	CUST	SUP
DRAWN BY		DW		MAT'L:		SCALE	
DATE		3-29-96		ABS		NONE	
CHECKED BY		CEF		DRAWING NO.		35544-04	
				SIZE		A	