

THIS COPY IS PROVIDED ON A RESTRICTED BASIS AND IS NOT TO BE USED IN ANY WAY DETRIMENTAL TO THE INTERESTS OF PANDUIT CORP.

| PANDUIT PART NUMBER | "A" in/(mm) | "B" REF. in/(mm) | "C" in/(mm) | "D" in/(mm) | "E" in/(mm) | WEIGHT lbs (g)/ 100 pcs |
|---------------------|-------------|------------------|-------------|-------------|-------------|-------------------------|
| CCH12-S10           | 0.12 (3.1)  | 0.36 (9.1)       | 0.050 (1.3) | 0.50 (12.7) | 0.203 (5.1) | 0.12 (52.5)             |
| CCH19-S10           | 0.19 (4.8)  | 0.42 (10.7)      | 0.050 (1.3) | 0.50 (12.7) | 0.203 (5.1) | 0.15 (67.2)             |
| CCH25-S10           | 0.25 (6.3)  | 0.46 (11.7)      | 0.050 (1.3) | 0.50 (12.7) | 0.203 (5.1) | 0.16 (74.0)             |
| CCH31-S10           | 0.31 (7.9)  | 0.50 (12.7)      | 0.050 (1.3) | 0.50 (12.7) | 0.203 (5.1) | 0.18 (83.7)             |
| CCH38-S10           | 0.38 (9.5)  | 0.53 (13.5)      | 0.050 (1.3) | 0.50 (12.7) | 0.203 (5.1) | 0.23 (105.8)            |
| CCH44-S10           | 0.44 (11.1) | 0.56 (14.2)      | 0.050 (1.3) | 0.50 (12.7) | 0.203 (5.1) | 0.22 (99.4)             |
| CCH50-S10           | 0.50 (12.7) | 0.59 (15.0)      | 0.050 (1.3) | 0.50 (12.7) | 0.203 (5.1) | 0.24 (109.1)            |
| CCH56-S10           | 0.56 (14.2) | 0.61 (15.5)      | 0.050 (1.3) | 0.50 (12.7) | 0.203 (5.1) | 0.25 (114.8)            |
| CCH62-S10           | 0.62 (15.7) | 0.65 (16.5)      | 0.050 (1.3) | 0.50 (12.7) | 0.203 (5.1) | 0.29 (131.1)            |
| CCH69-S10           | 0.69 (17.5) | 0.75 (19.1)      | 0.050 (1.3) | 0.50 (12.7) | 0.203 (5.1) | 0.33 (150.3)            |
| CCH75-S10           | 0.75 (19.1) | 0.78 (19.8)      | 0.050 (1.3) | 0.50 (12.7) | 0.203 (5.1) | 0.33 (149.3)            |
| CCH81-S10           | 0.81 (20.6) | 0.81 (20.6)      | 0.050 (1.3) | 0.50 (12.7) | 0.203 (5.1) | 0.34 (156.4)            |
| CCH87-S10           | 0.87 (22.1) | 0.84 (21.3)      | 0.050 (1.3) | 0.50 (12.7) | 0.203 (5.1) | 0.35 (160.9)            |
| CCH100-S10          | 1.00 (25.4) | 0.91 (23.1)      | 0.050 (1.3) | 0.50 (12.7) | 0.203 (5.1) | 0.46 (209.7)            |
| CCH112-S10          | 1.12 (28.4) | 0.97 (24.6)      | 0.050 (1.3) | 0.50 (12.7) | 0.203 (5.1) | 0.53 (239.2)            |
| CCH119-S10          | 1.19 (30.2) | 1.00 (25.4)      | 0.050 (1.3) | 0.50 (12.7) | 0.203 (5.1) | 0.57 (259.3)            |
| CCH125-S10          | 1.25 (31.8) | 1.06 (26.9)      | 0.050 (1.3) | 0.50 (12.7) | 0.203 (5.1) | 0.58 (260.8)            |
| CCH138-S10          | 1.37 (34.8) | 1.12 (28.4)      | 0.050 (1.3) | 0.50 (12.7) | 0.203 (5.1) | 0.64 (288.9)            |
| CCH150-S10          | 1.50 (38.1) | 1.19 (30.2)      | 0.050 (1.3) | 0.50 (12.7) | 0.203 (5.1) | 0.69 (310.9)            |

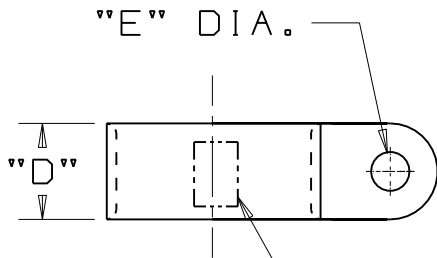

FRACTIONAL PART SIZE NOTED HERE.

"A" DIA WHEN CLOSED

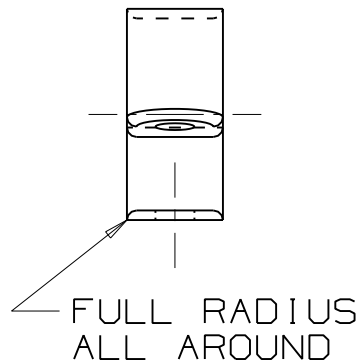
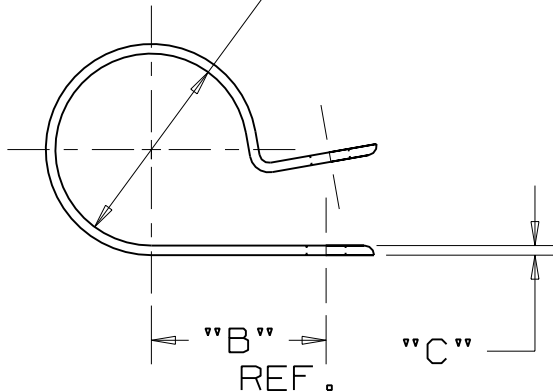

NOTES:

- SEE CURRENT PRICE SHEET FOR PART NUMBER SUFFIX DESIGNATION FOR PACKAGE SIZE AND PART COLOR.

(DIMENSIONS IN PARENTHESES ARE IN METRIC.)

CAD FILENAME/LAYERS

G00239DW\_P1\_CCH\_02

**PANDUIT**

CORP.

TINLEY PARK, ILLINOIS

CCH - CABLE CLAMP

UNLESS OTHERWISE SPECIFIED, DIMENSIONAL TOLERANCES ARE:  
 (.X) ±0.1(2.5) (.XXX) ±0.015(1.4)  
 (.XX) ±0.05(1.3) ANGLES ±5°

UNLESS OTHERWISE SPECIFIED, ALL DIMENSIONS ARE GIVEN IN INCHES, THIRD ANGLE PROJECTION.

DRAWN BY  
CJG

MAT'L:

SCALE

NONE

2 2/7/06 JAD UPDATE LOCATION OF FRACTIONAL PART SIZE INDICATOR

GBO239DW 2

DATE  
6/26/96

NYLON 6/6

DRAWING NO.

GBO239DW

DWG

A  
SIZE

REV DATE BY CHK DESCRIPTION

ECN - R CUST SUP

CHK'D