

3014 LED

PLW3014CA Series

Product Datasheet



Description

Plessey PLW3014CA SMT LEDs are designed for linear tubes, spot lights, indicator, bulb replacements and other general lighting applications. The light is emitted close to a Lambertian distribution and hence this SMT package is naturally suitable for backlighting panels and symbols. The LEDs are packed in reels containing 4000 pieces; each individual reel will be shipped in single intensity and colour bin, to provide close uniformity.

Features

- 3014 (3.05 x 1.40 x 0.70mm)
- Colour binning
- High reliability PLCC packaging
- Diffused pale yellow resin
- 120 degree wide viewing angle

Applications

- Decoration Lighting
- Instrument panel backlighting
- Illumination symbols
- General lighting
- Signage lighting

Variant	Colour	CCT	
		Min.	Max.
PLW3014CA-3000	Warm White 3000K	2700K	3225K
PLW3014CA-4000	Neutral White 4000K	3700K	4500K
PLW3014CA-5700	Cool White 5700K	5300K	6040K
PLW3014CA-6500	Cool White 6500K	6040K	7030K

Absolute Maximum Ratings

T_{amb} = +25°C unless otherwise stated

Parameter	Symbol	Minimum	Maximum	Unit
DC Forward Current	I _F	-	40	mA
Peak Pulse Forward Current ^[1]	I _{FP}	-	100	mA
Power Dissipation	P _d	-	130	mW
Storage Temperature	T _{stg}	-40	+100	°C
Junction Temperature	T _j		+115	°C

[1] Pulse width ≤10ms, duty cycle ≤10%

Electro-optical Characteristics

T_{amb} = +25°C unless otherwise stated

Parameter	Symbol	Condition	Min.	Typ.	Max.	Unit
Forward Voltage	V _F	I _F = 30mA	2.8	3.1	3.4	V
Reverse Current	I _R	V _R = 5V	-	-	10	µA
Colour Rendering Index	CRI	I _F = 30mA	80			%
Thermal Resistance	R _{thj-sp}		-	70	-	°C/W
Half-Intensity Angle	2Θ _{1/2}	I _F = 30mA	-	120	-	deg

Recommended Operating Conditions

In typical applications, for optimum LED performance

Parameter	Symbol	Minimum	Maximum	Unit
Operating Ambient Temperature	T _{opr}	-40	+85	°C

Ordering Information

Name	Order Code	Luminous Flux Range	Forward Voltage Range
PLW3014CA-3000	PLW3014CAW30000	1A, 2A, 3A, 4A, 5A	V1-V6
PLW3014CA-4000	PLW3014CAN40000	2A, 3A, 4A, 5A, 6A	
PLW3014CA-5700	PLW3014CAC57000		
PLW3014CA-6500	PLW3014CAC65000		

Intensity Bin Groups

$I_F = 30\text{mA}$, $T_{\text{amb}} = +25^\circ\text{C}$, unless otherwise stated

Group	Luminous flux ^[1] (lm)	
	Min.	Max.
1A	9	10
2A	10	11
3A	11	12
4A	12	13
5A	13	14
6A	14	15

^[1] Tolerance $\pm 7\%$

Forward Voltage Bin Groups

$I_F = 30\text{mA}$, $T_{\text{amb}} = +25^\circ\text{C}$, unless otherwise stated

Group	V_F ^[1] (V)	
	Min.	Max.
V1	2.8	2.9
V2	2.9	3.0
V3	3.0	3.1
V4	3.1	3.2
V5	3.2	3.3
V6	3.3	3.4

^[1] Tolerance $\pm 0.1\text{V}$

Chromaticity Binning

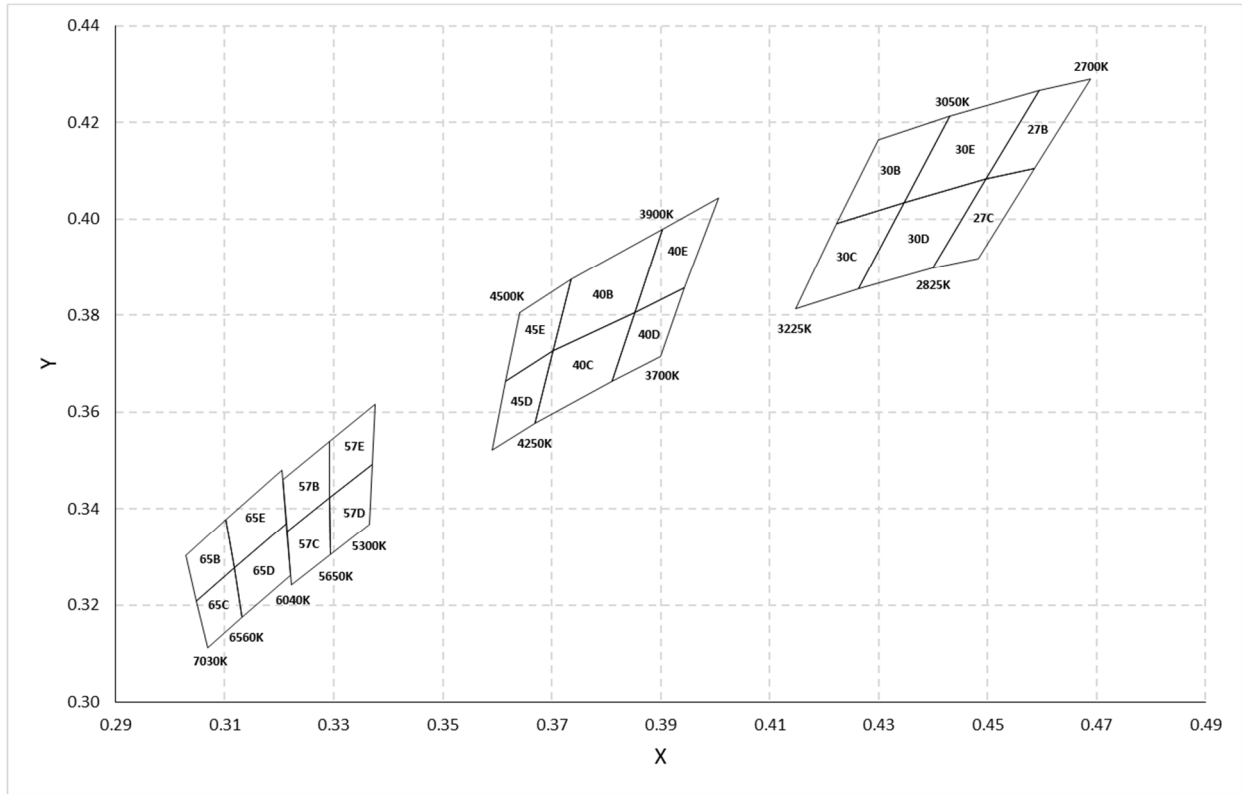

Figure 1. Colour Chromaticity Binning

	X1	Y1	X2	Y2	X3	Y3	X4	Y4
57B	0.3206	0.3461	0.3292	0.3539	0.3293	0.3423	0.3214	0.3352
57C	0.3214	0.3352	0.3293	0.3423	0.3294	0.3306	0.3222	0.3243
57D	0.3293	0.3423	0.3371	0.3493	0.3366	0.3369	0.3294	0.3306
57E	0.3292	0.3539	0.3376	0.3616	0.3371	0.3493	0.3293	0.3423
65B	0.3028	0.3304	0.3102	0.3378	0.3117	0.3277	0.3048	0.3209
65C	0.3048	0.3209	0.3117	0.3277	0.3132	0.3175	0.3068	0.3113
65D	0.3117	0.3277	0.3213	0.3371	0.3221	0.3261	0.3132	0.3175
65E	0.3102	0.3378	0.3205	0.3481	0.3213	0.3371	0.3117	0.3277
45D	0.3591	0.3521	0.3616	0.3663	0.3703	0.3726	0.3670	0.3578
45E	0.3616	0.3663	0.3642	0.3805	0.3736	0.3874	0.3703	0.3726
40B	0.3703	0.3726	0.3736	0.3874	0.3903	0.3979	0.3852	0.3806
40C	0.3670	0.3578	0.3703	0.3726	0.3852	0.3806	0.3810	0.3663
40D	0.3810	0.3663	0.3852	0.3806	0.3944	0.3856	0.3899	0.3716
40E	0.3852	0.3806	0.3903	0.3979	0.4006	0.4044	0.3944	0.3856
30B	0.4223	0.3990	0.4299	0.4165	0.4431	0.4213	0.4347	0.4034
30C	0.4147	0.3814	0.4223	0.3990	0.4347	0.4034	0.4262	0.3854
30D	0.4262	0.3854	0.4347	0.4034	0.4497	0.4084	0.4399	0.3899
30E	0.4347	0.4034	0.4431	0.4213	0.4594	0.4267	0.4497	0.4084
27B	0.4497	0.4084	0.4594	0.4267	0.4689	0.4290	0.4586	0.4105
27C	0.4399	0.3899	0.4497	0.4084	0.4586	0.4105	0.4483	0.3918

Relative Spectral Emission

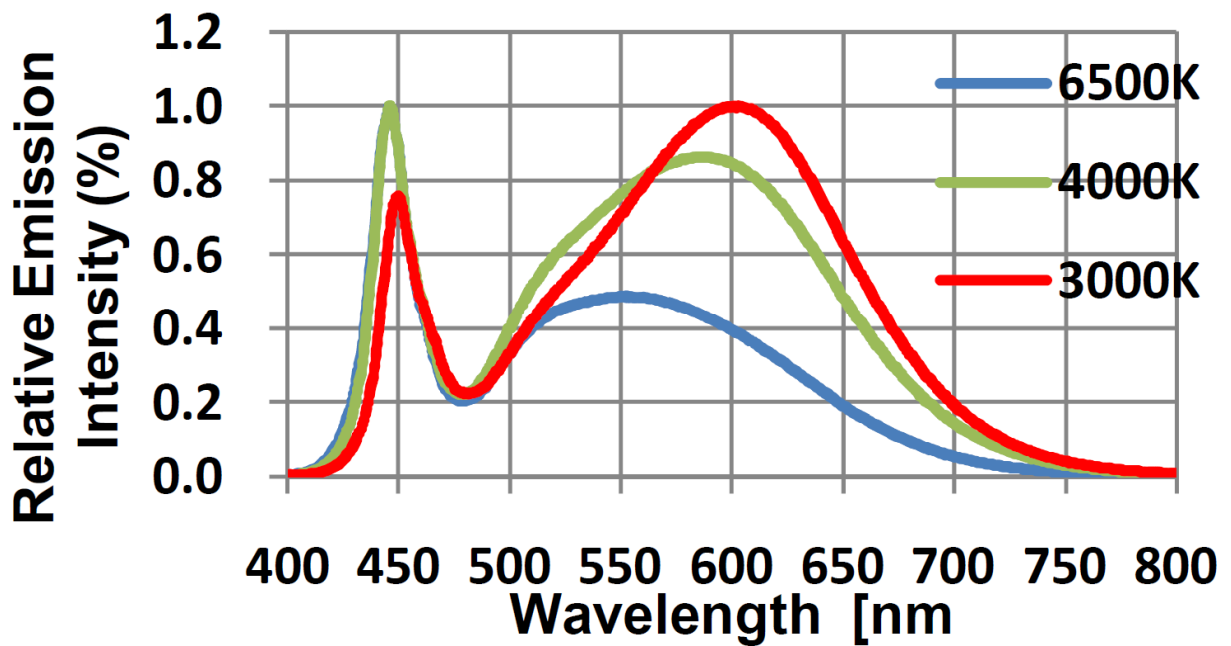

Figure 2. Normalised spectral power distribution (3000K, 4000K & 6500K)

Note: The relative spectral emission corresponds to a random LED sample

Angular Light Distribution

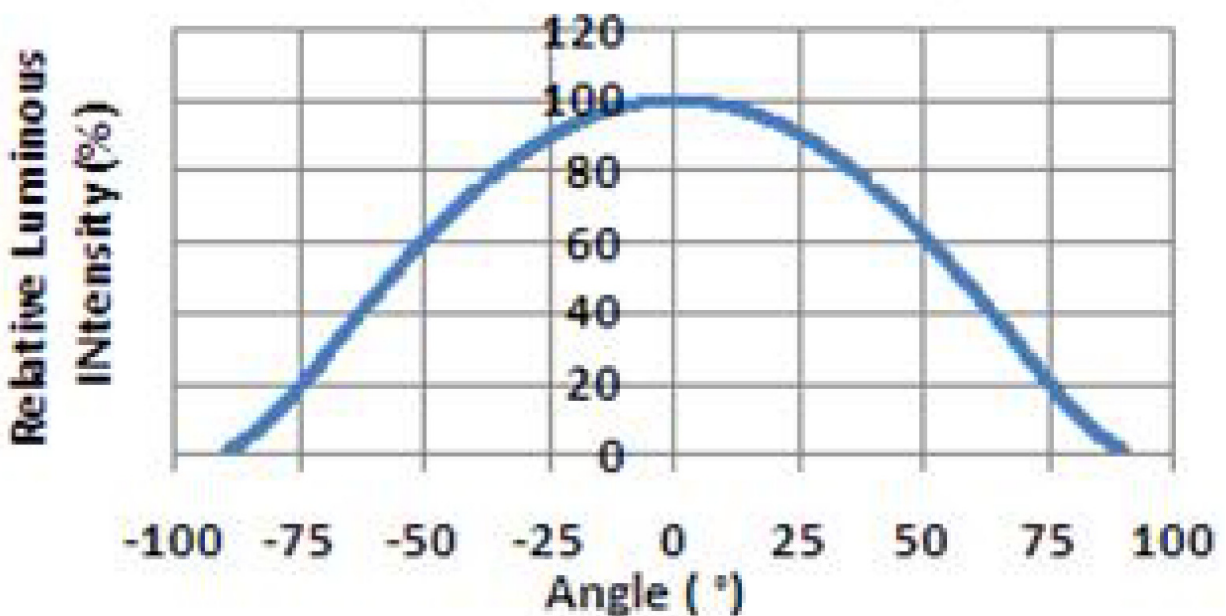

Figure 3. Angular distribution pattern of emitted light

Forward Current Characteristics

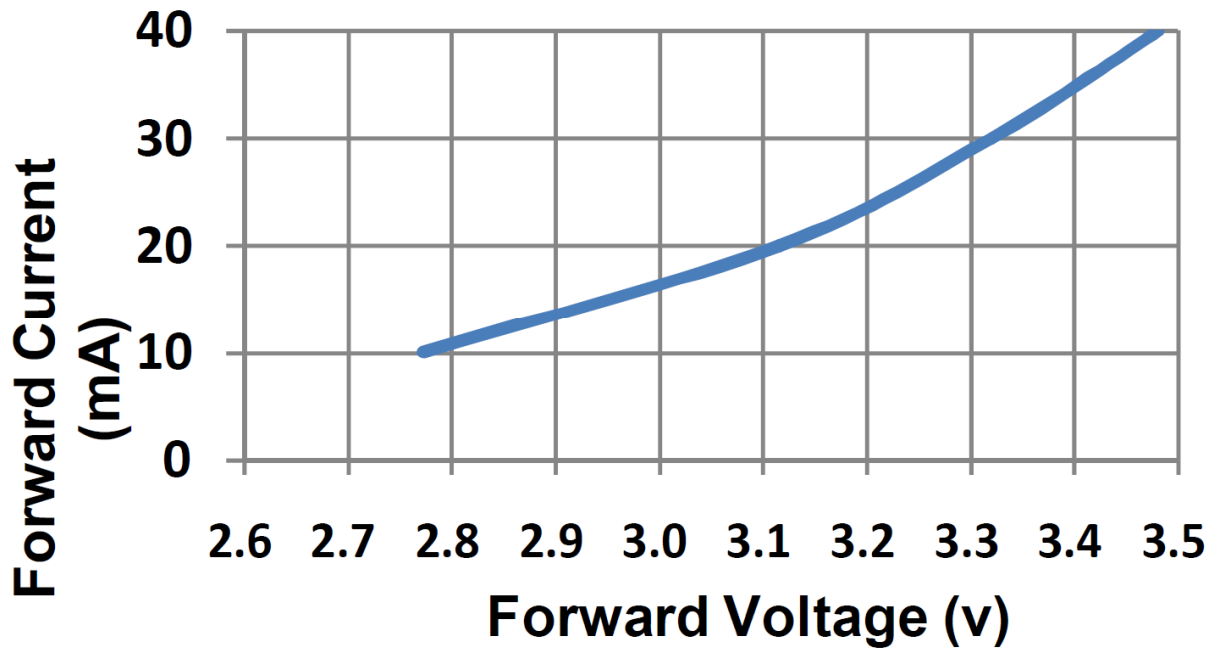

Figure 4. Typical forward current versus forward voltage ($T_a=+25C$)

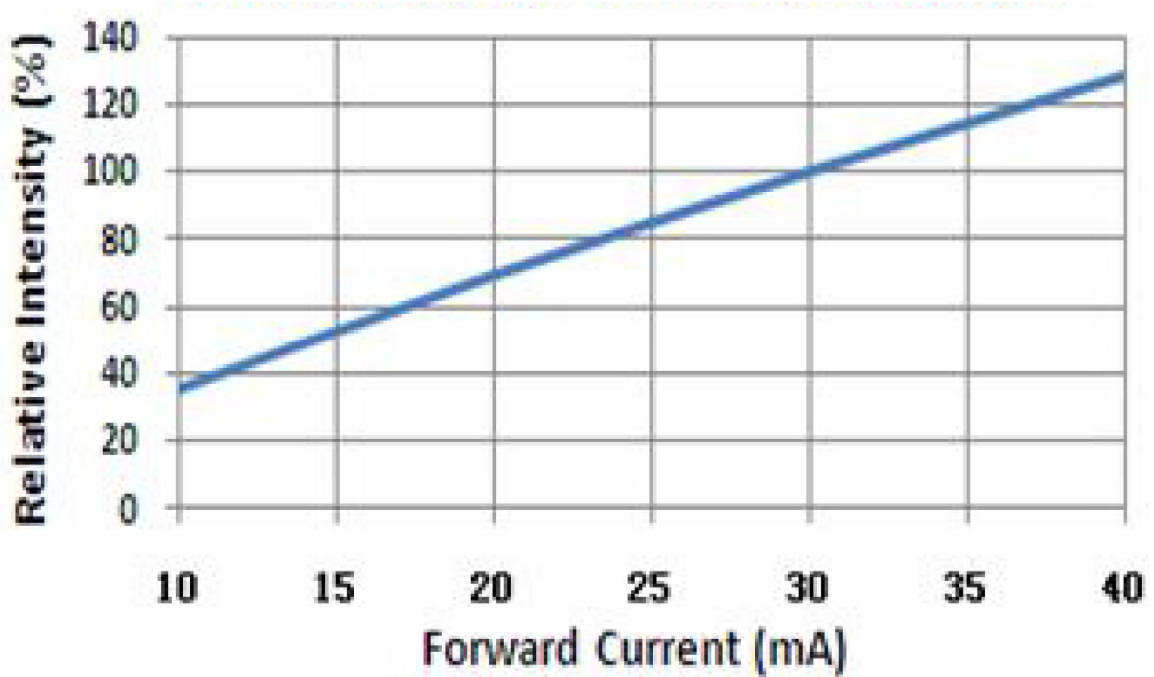

Figure 5. Relative luminous flux versus forward current ($T_a=+25C$)

Temperature Characteristics

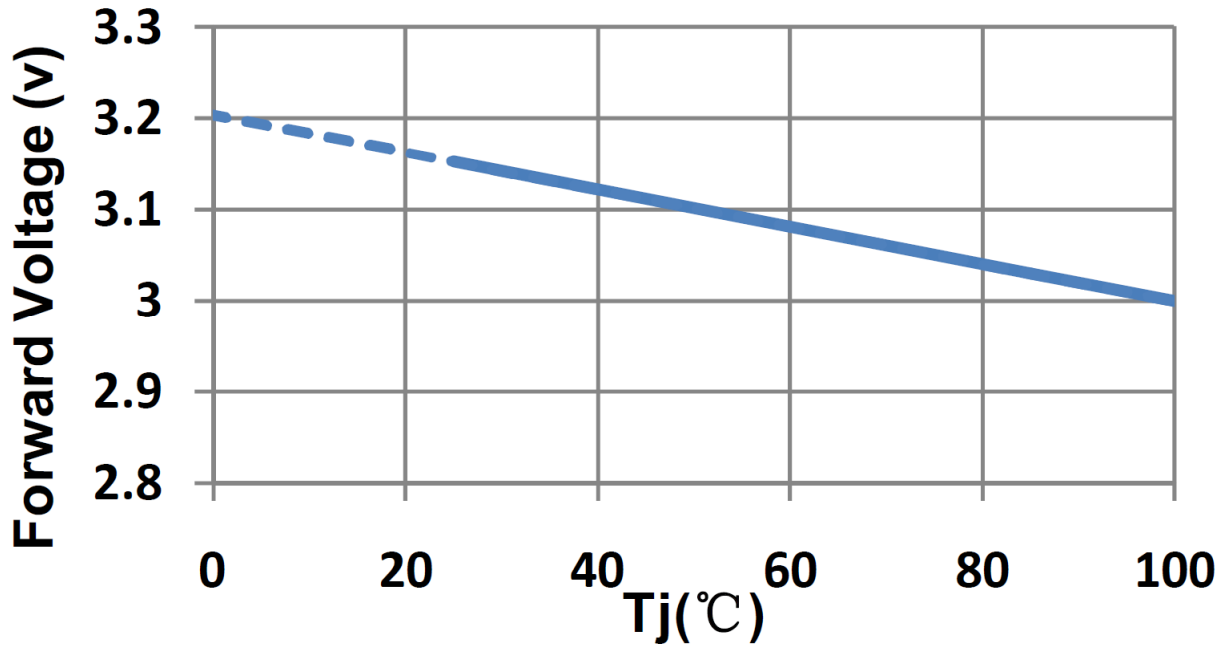

Figure 6. Typical forward voltage versus junction temperature ($I_F=30mA$)

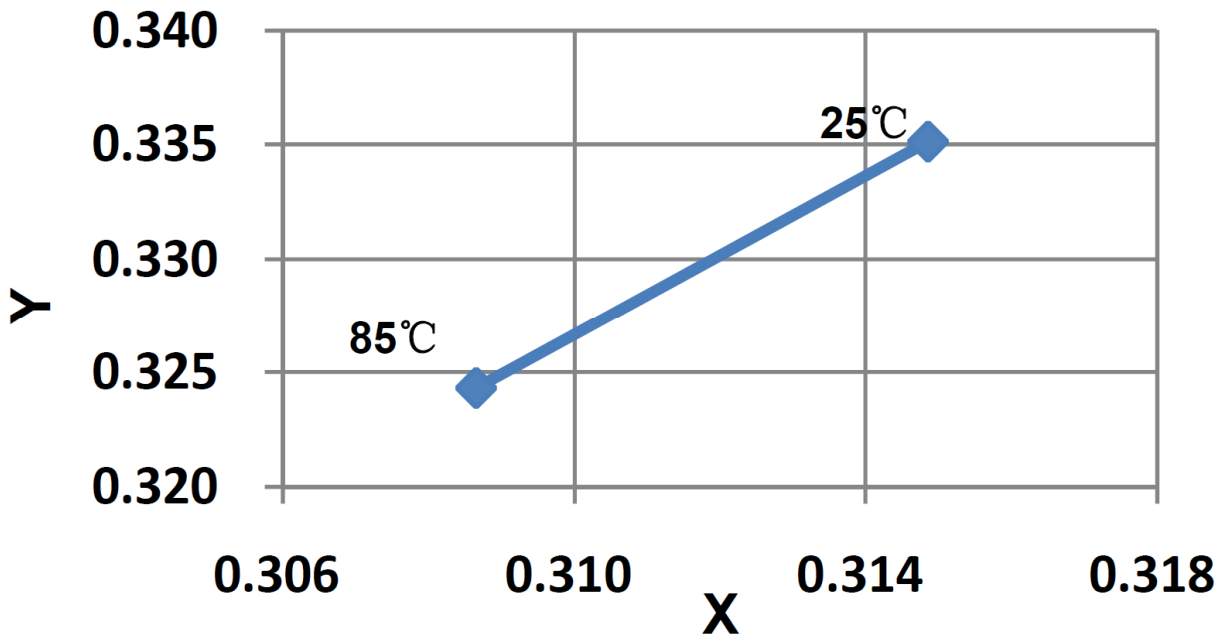

Figure 7. Chromaticity coordinates versus ambient temperature

Temperature Characteristics

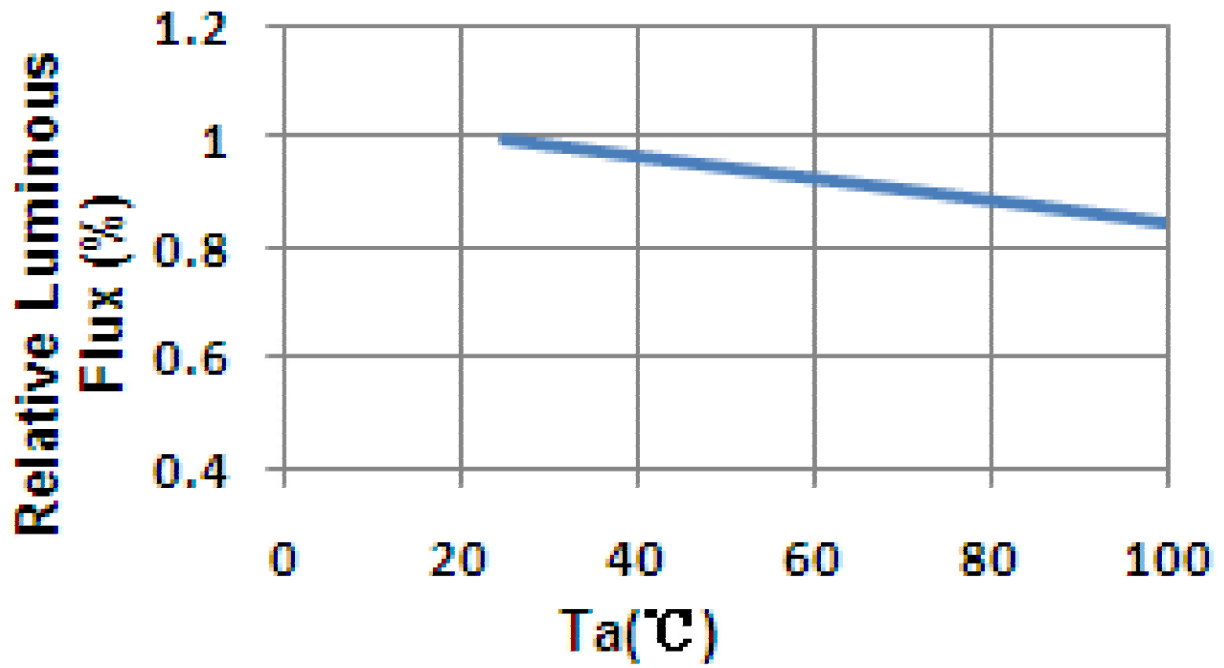

Figure 8. Ambient Temperature vs Relative Intensity

Package Outline Dimensions

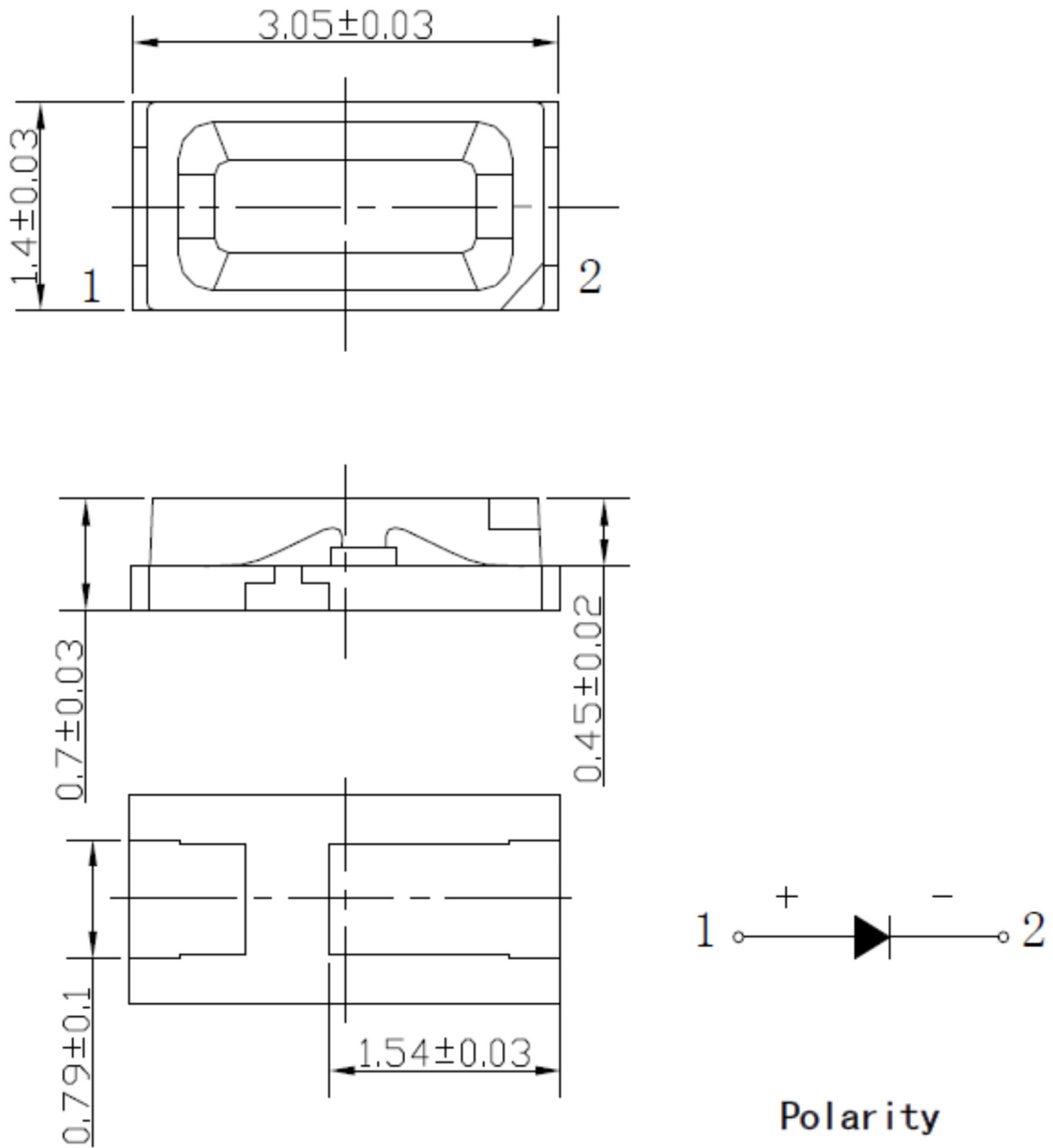

Figure 9. Mechanical drawings of the 3014 package (unit in mm)

Recommended Solder Pad

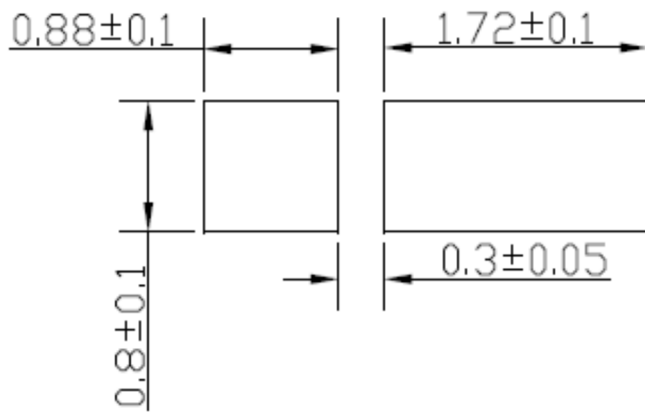

Figure 10. Diagram of soldering pad (unit in mm)

Note: Increased PCB Cu area will reduce the T_j and increase reliability

Reflow Soldering Profile

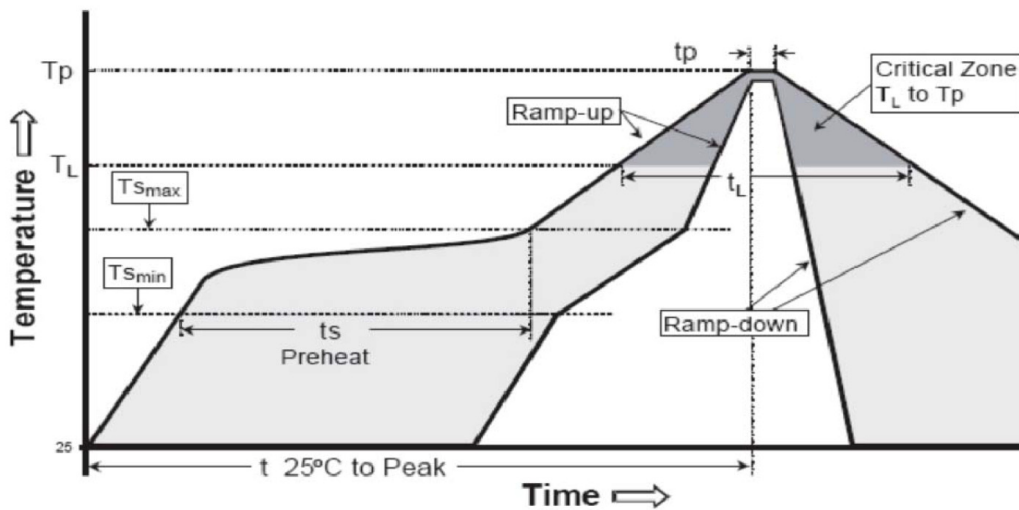

Figure 11. Reflow soldering profile

Reflow Soldering Characteristics

Profile Feature	Sn-Pb Eutectic Assembly	Pb-Free Assembly
Average ramp-up rate (T_s max to T_p)	Max 3°C/sec	Max 3°C/sec
Preheat: Min Temperature (T_{s_min})	100°C	150°C
Preheat: Max Temperature (T_{s_max})	150°C	200°C
Preheat: Time (T_{s_min} to T_{s_max})	60 – 120 sec	60 – 180 sec
Time maintained above: Temperature (T_L)	183°C	217°C
Time maintained above: Time (t_L)	60 – 150 sec	60 – 150 sec
Peak/Classification Temperature T_p	215°C	260°C
Storage time within 5°C of actual peak t_p	10 – 30 sec	20 – 40 sec
Ramp-down rate	Max 6°C/sec	Max 6°C/sec
Time required 25°C to peak temperature	Max 6 mins	Max 8 mins

1. Reflow soldering should not be done more than twice
2. When soldering, do not put stress on the LEDs during heating

Soldering iron

1. When hand soldering, the temperature of the iron must be $\leq +300^\circ\text{C}$ for 3 seconds
2. Hand soldering should be performed only once.

Moisture Sensitivity

JEDEC Level	Floor life		Bake	
	Time	Conditions	Time	Conditions
2a	4 weeks	≤+30°C / 60% RH	≥58 hours	+60°C ±5°C / 5% RH

Handling Instructions

Plessey LEDs are not designed to operate with reverse bias.

Precautions are required to prevent reverse bias in applications and during handling.



Packing Information

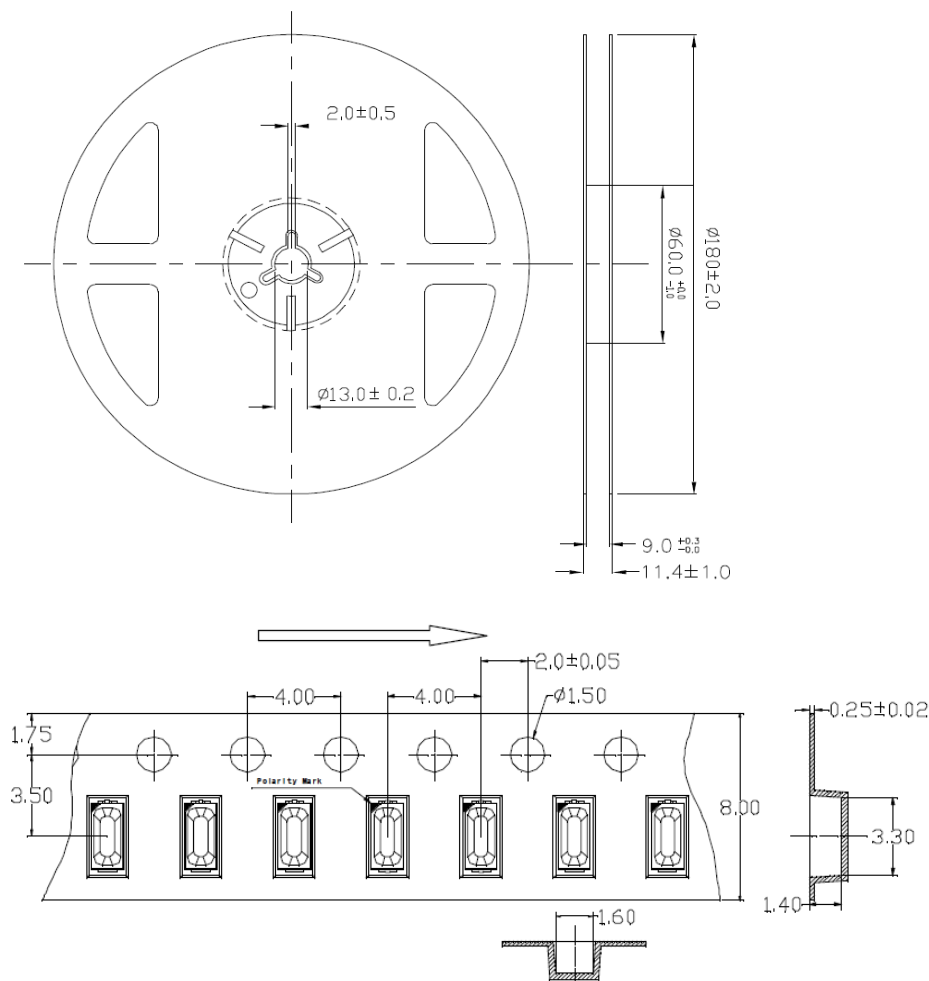

Figure 12. Reel specification (unit in mm)

Legal Notice

Product information provided by Plessey Semiconductors Limited (“Plessey”) in this document is believed to be correct and accurate. Plessey reserves the right to change/correct the specifications and other data or information relating to products without notice but Plessey accepts no liability for errors that may appear in this document, howsoever occurring, or liability arising from the use or application of any information or data provided herein. Neither the supply of such information, nor the purchase or use of products conveys any licence or permission under patent, copyright, trademark or other intellectual property right of Plessey or third parties.

Products sold by Plessey are subject to its standard Terms and Conditions of Sale that are available on request. No warranty is given that products do not infringe the intellectual property rights of third parties, and furthermore, the use of products in certain ways or in combination with Plessey, or non-Plessey furnished equipments/components may infringe intellectual property rights of Plessey.

The purpose of this document is to provide information only and it may not be used, applied or reproduced (in whole or in part) for any purpose nor be taken as a representation relating to the products in question. No warranty or guarantee express or implied is made concerning the capability, performance or suitability of any product, and information concerning possible applications or methods of use is provided for guidance only and not as a recommendation. The user is solely responsible for determining the performance and suitability of the product in any application and checking that any specification or data it seeks to rely on has not been superseded.

Products are intended for normal commercial applications. For applications requiring unusual environmental requirements, extended temperature range, or high reliability capability (e.g. military, or medical applications), special processing/testing/conditions of sale may be available on application to Plessey.

Contact

Customer Support

+44 1752 693000 | support@plesseysemi.com

www.plesseysemi.com

Plessey Semiconductors Ltd | Plymouth
Tamerton Road, Roborough
Plymouth, Devon
PL6 7BQ United Kingdom

P: +44 1752 693000

F: +44 1752 693700