

Pomona PLCC Test Adapters Model Numbers: 5279, 5280, 5733, 5281, 5312, 5401 & 5402 Chip Lead Spacing: 0.050"

These new test adapters are designed for testing surface mounted PLCC chips with "J" leads (JEDEC MO-047 and MO-052).

The patented lock-on design attaches directly to the surface mounted IC and provides hands-free access to all of the chip leads.

- Gold plated upper contacts assure noise free, low resistance connections. Standard .025 square pins accept wire-wrap, .025 sq. receptacle or soldered wires. Pins are staggered to use the least space
- Gold plated lower contacts assure the best connection the chip leads.
- Material: Gray, glass-filled nylon.

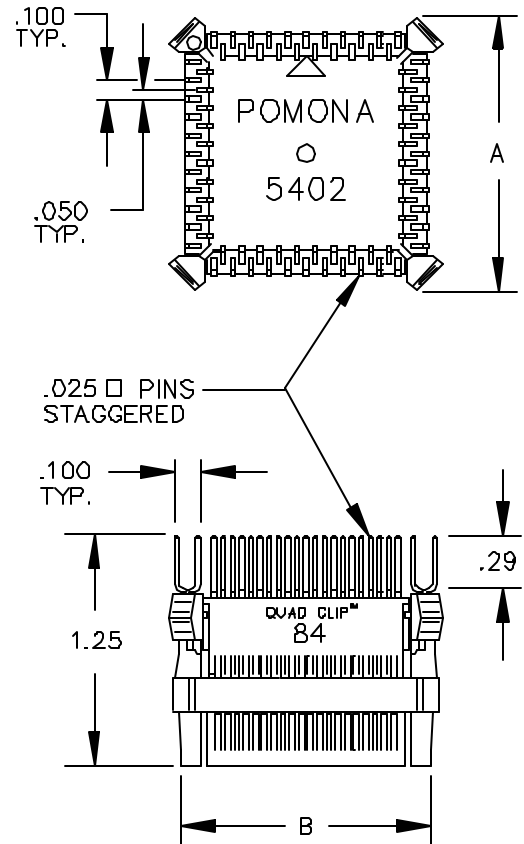

Model 5515A is a kit that contains all seven sizes of PLCC Test Clips.

Model Number	No. of Pins	Pins Per Side	Space Required "B"	Board Footprint "A"	Model Number	No. of Pins	Pins Per Side	Space Required "B"	Board Footprint "A"
5279	20	5x5	.675"	0.560"	5312	52	13x13	1.075"	0.965"
5280	28	7x7	.775"	0.665"	5401	68	17x17	1.275"	1.180"
5733	32	7x9	.775"x.875"	.665" x .765"	5402	84	21x21	1.520"	1.350"
5281	44	11x11	.975"	0.865"					

All dimensions are in inches. Tolerances (except noted): .xx = ±.02" (.51 mm), .xxx = ±.005" (.127 mm). All specifications are to the latest revisions. Specifications are subject to change without notice. Registered trademarks are the property of their respective companies. Made in USA