

### ●Features

- 1) Special construction prevents sulfur gas penetration, significantly increasing reliability.
- 2) ROHM resistors have obtained ISO9001 / ISO / TS16949 certification.

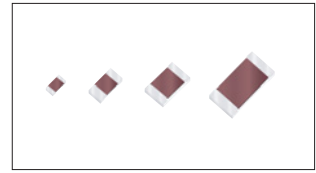

### ●Products List

Part No.	Size		Rated Power (70°C) (W)	Limiting Element Voltage (V)	Temperature Coefficient (ppm / °C)	Resistance Tolerance (%)	Resistance Range	Series	Operating Temperature Range (°C)
	(mm)	(inch)							
TRR01	1005	0402	0.063	50	+500 / -250	J(±5%)	1Ω to 9.1Ω	E24	-55 to +155
					±200		10Ω to 10MΩ		
					±100	10Ω to 2.2MΩ			
Jumper type : Rmax = 50mΩ / Imax. = 1A									
TRR03	1608	0603	0.1	50	±400	J(±5%)	1Ω to 9.1Ω	E24	-55 to +155
					±200		10Ω to 10MΩ		
					±100	10Ω to 10MΩ			
Jumper type : Rmax = 50mΩ / Imax. = 1A									
TRR10	2012	0805	0.125	150	±400	J(±5%)	1Ω to 9.1Ω	E24	-55 to +155
					±200		10Ω to 10MΩ		
					±100	10Ω to 2.2MΩ			
Jumper type : Rmax = 50mΩ / Imax. = 2A									
TRR18	3216	1206	0.25	200	±400	J(±5%)	1Ω to 9.1Ω	E24	-55 to +155
					±200		10Ω to 10MΩ		
					±100	10Ω to 2.2MΩ			
Jumper type : Rmax = 50mΩ / Imax. = 2A									

\*Design and specifications are subject to change without notice.  
Carefully check the specification sheet supplied with the product before using or ordering it.

### ●Part Number Description

<b>T</b> <b>R</b> <b>R</b>	<b>0</b> <b>1</b>	<b>M</b> <b>Z</b> <b>P</b>	<b>J</b>	<b>1</b> <b>0</b> <b>5</b>																										
<b>Part No.</b> <b>TRR</b> (Sulfur Tolerant Chip Resistors)	<b>Size (mm [inch])</b> 01 (1005 [0402]) 03 (1608 [0603]) 10 (2012 [0805]) 18 (3216 [1206])	<b>Packaging Specifications Code</b> <table border="1"> <thead> <tr> <th>Part No.</th> <th>Code</th> <th>Packaging specifications</th> <th>Quantity / Reel</th> </tr> </thead> <tbody> <tr> <td>TRR01</td> <td>MZP</td> <td>Paper tape (2mm Pitch)</td> <td>10,000</td> </tr> <tr> <td>TRR03</td> <td>EZP</td> <td>Paper tape (4mm Pitch)</td> <td>5,000</td> </tr> <tr> <td>TRR10</td> <td>EZP</td> <td>Paper tape (4mm Pitch)</td> <td>5,000</td> </tr> <tr> <td>TRR18</td> <td>EZP</td> <td>Paper tape (4mm Pitch)</td> <td>5,000</td> </tr> </tbody> </table>	Part No.	Code	Packaging specifications	Quantity / Reel	TRR01	MZP	Paper tape (2mm Pitch)	10,000	TRR03	EZP	Paper tape (4mm Pitch)	5,000	TRR10	EZP	Paper tape (4mm Pitch)	5,000	TRR18	EZP	Paper tape (4mm Pitch)	5,000	<b>Resistance Tolerance</b> F ( ±1% ) J ( ±5% )	<b>Nominal Resistance</b> Resistance code, 3 or 4 digits. 000 denotes jumper type. <table border="1"> <thead> <tr> <th>Resistance tolerance</th> <th>Resistance code</th> </tr> </thead> <tbody> <tr> <td>F</td> <td>: 4 digits</td> </tr> <tr> <td>J</td> <td>: 3 digits</td> </tr> </tbody> </table> <p>Ex.)</p> <p>1Ω = 1R0 ( ±5% )            9.1Ω = 9R1 ( ±5% )            10Ω = 10R0 ( ±1% )            100 ( ±5% )            1MΩ = 1004 ( ±1% )            105 ( ±5% )</p>	Resistance tolerance	Resistance code	F	: 4 digits	J	: 3 digits
Part No.	Code	Packaging specifications	Quantity / Reel																											
TRR01	MZP	Paper tape (2mm Pitch)	10,000																											
TRR03	EZP	Paper tape (4mm Pitch)	5,000																											
TRR10	EZP	Paper tape (4mm Pitch)	5,000																											
TRR18	EZP	Paper tape (4mm Pitch)	5,000																											
Resistance tolerance	Resistance code																													
F	: 4 digits																													
J	: 3 digits																													

●Chip Resistor Dimensions and Markings

■ TRR01 / 03

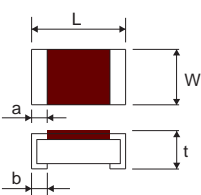

■ TRR10 / 18

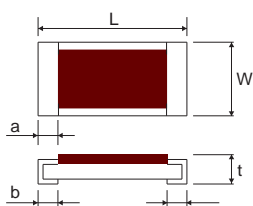

(Unit : mm)

Part No.	(mm)	(inch)	L	W	t	a	b	Marking existence *Including jumper type
TRR01	1005	0402	1.0±0.05	0.5±0.05	0.35±0.05	0.33±0.08	0.25 <sup>+0.05</sup> <sub>-0.1</sub>	No
TRR03	1608	0603	1.6±0.1	0.8±0.1	0.45±0.1	0.4±0.1	0.3±0.2	No
TRR10	2012	0805	2.0±0.1	1.25±0.1	0.55±0.1	0.43 <sup>+0.15</sup> <sub>-0.1</sub>	0.4±0.2	No
TRR18	3216	1206	3.2±0.15	1.6±0.15	0.55±0.1	0.69 <sup>+0.2</sup> <sub>-0.15</sub>	0.5±0.25	No

●Land pattern Example

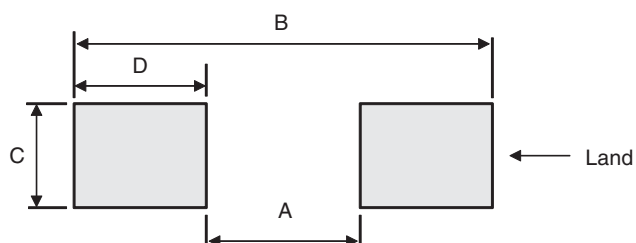

(Unit : mm)

Dimensions Part No.	A	B	C	D
TRR01	0.5	1.3	0.5	0.4
TRR03	1.0	2.0	0.8	0.5
TRR10	1.2	2.6	1.15	0.7
TRR18	2.2	4.0	1.5	0.9

### ●Derating Curve

When the ambient temperature exceeds 70°C, power dissipation must be adjusted according to the derating curves below.

■ TRR01 / 03 / 10 / 18

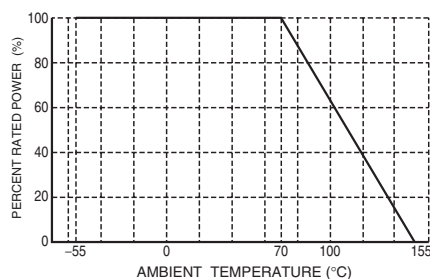

### ●Characteristics

Test Items	Guaranteed Value		Test Conditions
	Resistor Type	Jumper Type	
Resistance	See P.1		20°C
Variation of resistance with temperature	See P.1		Measurement : +20 / -55 / +20 / +125°C
Overload	± (2.0%+0.1Ω)	Max. 50mΩ	Rated voltage (current) ×2.5, 2s Maximum overload voltage
Solderability	A new uniform coating of minimum of 95% of the surface being immersed and no soldering damage.		Rosin-Ethanol : 25% (Weight) Soldering condition : 235±5°C Duration of immersion : 2.0±0.5s
Resistance to soldering heat	± (1.0%+0.05Ω) No remarkable abnormality on the appearance.	Max. 50mΩ	Soldering condition : 260±5°C Duration of immersion : 10±1s
Rapid change of temperature	± (1.0%+0.05Ω)	Max. 50mΩ	Test temp. : -55°C to +125°C 5cycle
Damp heat, steady state	± (3.0%+0.1Ω)	Max. 100mΩ	40°C, 93%RH (Relative Humidity) Test time : 1,000h to 1,048h
Endurance at 70°C	± (3.0%+0.1Ω)	Max. 100mΩ	70°C Rated voltage (current) 1.5h : ON – 0.5h : OFF Test time : 1,000h to 1,048h
Endurance	± (3.0%+0.1Ω)	Max. 100mΩ	155°C Test time : 1,000h to 1,048h
Resistance to solvent	± (1.0%+0.05Ω)	Max. 50mΩ	23±5°C, Immersion cleaning, 5±0.5min Solvent : 2-propanol
Bend strength of the end face plating	± (1.0%+0.05Ω) Without mechanical damage such as breaks.	Max. 50mΩ	-

Compliance Standard(s) : IEC60115-8  
JISC 5201-8

●Tape Dimensions

■ Paper Tape

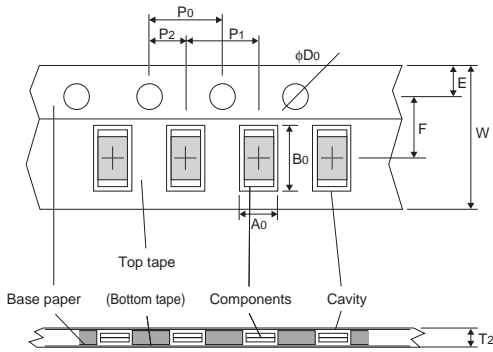

(Unit : mm)

Part No.	W	F	E	A0	B0
<b>TRR01</b>	8.0±0.3	3.5±0.05	1.75±0.1	0.7±0.1	1.2±0.1
<b>TRR03</b>	8.0±0.3	3.5±0.05	1.75±0.1	1.1±0.1	1.9±0.1
<b>TRR10</b>	8.0±0.3	3.5±0.05	1.75±0.1	1.65 <sup>+0.2</sup> <sub>-0.1</sub>	2.4 <sup>+0.2</sup> <sub>-0.1</sub>
<b>TRR18</b>	8.0±0.3	3.5±0.05	1.75±0.1	1.95 <sup>+0.1</sup> <sub>-0.05</sub>	3.5 <sup>+0.15</sup> <sub>-0.05</sub>

Part No.	D0	P0	P1	P2	T2
<b>TRR01</b>	φ1.5 <sup>+0.1</sup> <sub>0</sub>	4.0±0.1	2.0±0.05	2.0±0.05	Max 1.1
<b>TRR03</b>	φ1.5 <sup>+0.1</sup> <sub>0</sub>	4.0±0.1	4.0±0.1	2.0±0.05	Max 1.1
<b>TRR10</b>	φ1.5 <sup>+0.1</sup> <sub>0</sub>	4.0±0.1	4.0±0.1	2.0±0.05	Max 1.1
<b>TRR18</b>	φ1.5 <sup>+0.1</sup> <sub>0</sub>	4.0±0.1	4.0±0.1	2.0±0.05	Max 1.1

●Reel Dimensions

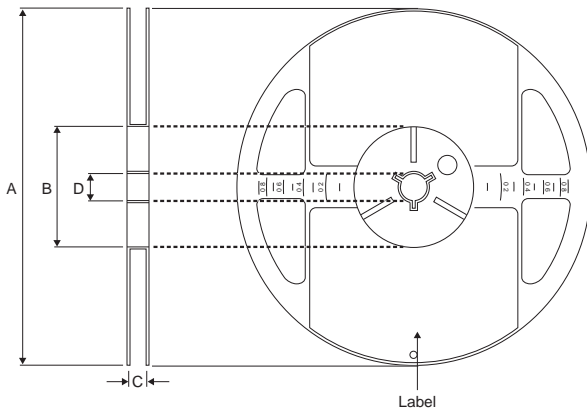

ACCORDING TO EIAJ ET-7200B

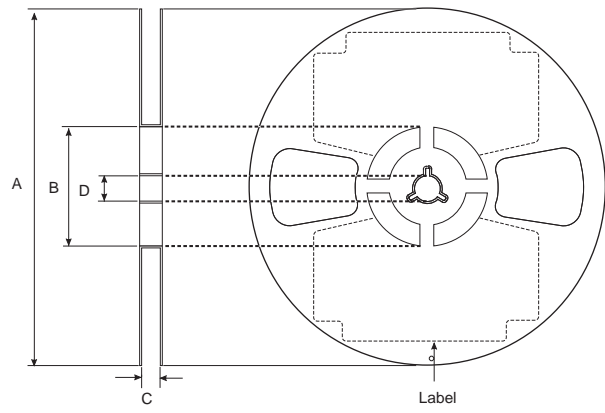

ACCORDING TO EIAJ ET-7200B (RRV)

(Unit : mm)

Part No.	A	B	C	D
<b>TRR01</b>	φ180 <sup>0</sup> <sub>-1.5</sub>	φ60 <sup>+1.0</sup> <sub>0</sub>	9 <sup>+1.0</sup> <sub>0</sub>	φ13±0.2
<b>TRR03</b>				
<b>TRR10</b>				
<b>TRR18</b>				