

REVISIONS			
REV.	DESCRIPTION	DATE	APPROVED
A	INITIAL RELEASE	07/15/09	A.D.M.

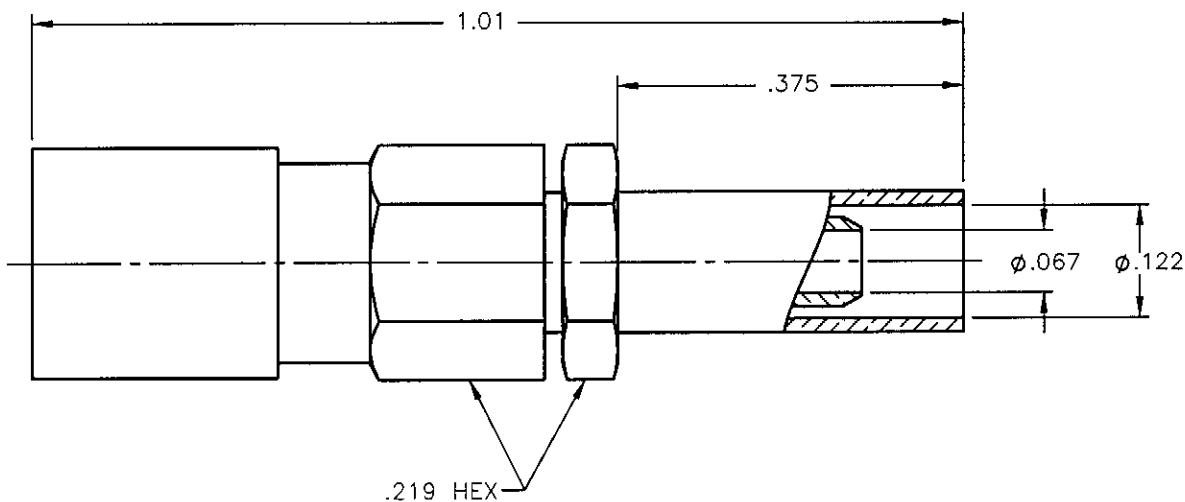

NOTES: CONFORMS TO MIL-C-39012/67B0009.



MATERIALS:

1. BODY & CRIMP NUT = BRASS PER ASTM B16, ALLOY C36000, TEMPER H02.
2. INSULATORS = VIRGIN WHITE TEFLON PER ASTM D1710, GRADE 1, TYPE I, CLASS "B".
3. CONTACT & SPRING = BERYLLIUM COPPER PER ASTM B196, ALLOY C17300, TEMPER TD04.
4. CRIMP SLEEVE = SEAMLESS LOWLEAD BRASS TUBE, ALLOY 330, SOFT ANNEAL TEMPER, .025/.060 GRAIN SIZE OR SEAMLESS COPPER TUBE PER ASTM B75, TYPE C12000, TEMPER: LIGHT ANNEAL 050 EXCEPT YIELD STRENGTH.
5. SLEEVE = BRASS PER ASTM B16, ALLOY C36000, TEMPER H02, BRASS SPEC'D @ 75-82 ROCKWELL "B" TENSILE STRENGTH 55-65 KPSI

FINISHES:

1. BODY = GOLD PLATE PER MIL-G-45204, TYPE II, CLASS 1, GRADE C, OVER .0001 TO .0002 COPPER STRIKE PER MIL-C-14550.
2. CONTACT = GOLD PLATE PER MIL-G-45204, TYPE II, CLASS 1, GRADE C, OVER .00010 TO .00020 STRESS FREE SULFAMATE NICKEL PER QQ-N-290.
3. SPRING = GOLD PLATE PER MIL-G-45204, TYPE II, CLASS 0, GRADE D, OVER .00010 TO .00020 COPPER STRIKE PER MIL-C-14550.
4. ALL OTHER METAL PARTS = GOLD PLATE PER MIL-G-45204, TYPE II, CLASS 0, GRADE C, OVER .00010 TO .00020 COPPER STRIKE PER MIL-C-14550.

Property of Radiall Incorporated
This document cannot be reproduced or
communicated to a third party without prior
written permission of RADIALL Incorporated.

UNLESS OTHERWISE SPECIFIED DIMENSIONS ARE IN INCHES TOLERANCES ON	DWN: A.D.M.	DATE 07/15/09	 APPLIED ENGINEERING PRODUCTS 104 John W. Murphy Dr. New Haven, CT 06513			
	CHKD:	DATE 07/15/09				
DECIMAL	ANGLE	D.N.	SMB STRAIGHT FEMALE PLUG CRIMP TYPE FOR RG-316 & SIMILAR CABLES			
		APVD: J.M.			DATE 07/15/09	
REFERENCE:	MATERIALS & FINISHES: SEE NOTES		SIZE A	FSCM NO. 19505	DWG NO. 2002-1571-903	REV A
ORIGINATED: A.D.M. DATE: 07/15/09			SCALE 5:1	THIRD ANGLE PROJECTION 		SHEET 1 OF 1

2002-1571-903