

REVISIONS			
REV.	DESCRIPTION	DATE	APPROVED
A	INITIAL RELEASE	08/09/12	D.N.

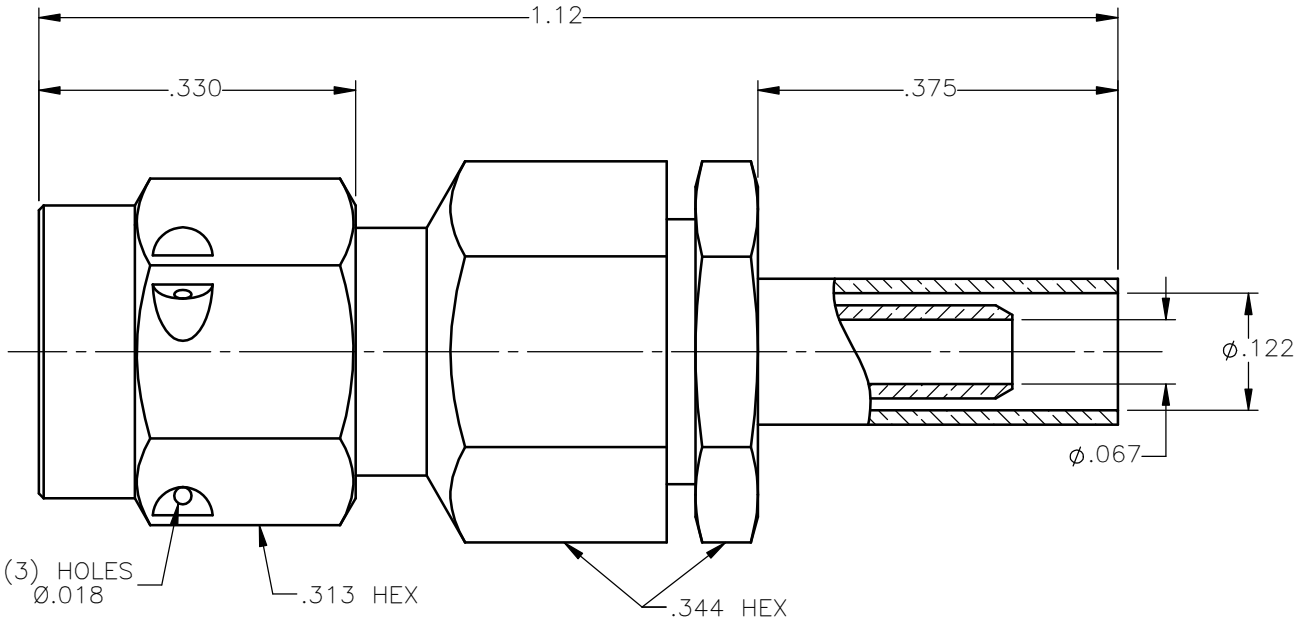

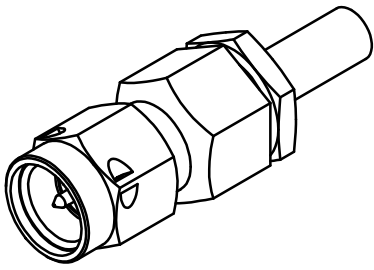

NOTES: CONFORMS TO MIL-PRF-39012/55-3026

MATERIALS:

1. BODY & COUPLING NUT = STAINLESS STEEL PER ASTM A582, ALLOY 303, CONDITION "A".
2. INSULATORS = VIRGIN WHITE TEFLON PER ASTM D1710, GRADE 1, TYPE I, CLASS "B".
3. CONTACT & RETAINING RING = BERYLLIUM COPPER PER ASTM B196, ALLOY C17300, TEMPER TD04.
4. CRIMP NUT & WASHER = BRASS PER ASTM B16, ALLOY C36000, TEMPER H02.
5. CRIMP SLEEVE = SEAMLESS LOWLEAD BRASS TUBE, ALLOY 330, SOFT ANNEAL TEMPER, .025/.060 GRAIN SIZE OR SEAMLESS COPPER TUBE PER ASTM B75, TYPE C12000, TEMPER: LIGHT ANNEAL O50 EXCEPT YIELD STRENGTH.
6. GASKET = SILICONE RUBBER PER ZZ-R-765, CLASS 2B, GRADE 65-75.
7. SHRINK SLEEVE = THERMOFIT SCL, BLACK (NOT SHOWN).

FINISHES:

1. BODY & COUPLING NUT = PASSIVATE PER QQ-P-35, TYPE VI.
2. CONTACT = GOLD PLATE PER MIL-G-45204, TYPE II, CLASS 1, GRADE C, OVER .00010 TO .00020 STRESS FREE SULFAMATE NICKEL PER QQ-N-290.
3. ALL OTHER METAL PARTS = NICKEL PLATE PER QQ-N-290, CLASS 1, GRADE G, EXCEPT .0001 TO .0002 THICK OVER .00005 TO .0001 THICK COPPER PER MIL-C-14550.

UNLESS OTHERWISE SPECIFIED DIMENSIONS ARE IN INCHES TOLERANCES ON	DWN:	DATE		Property of Radiall			
	D.N.	08/09/12		This document cannot be reproduced or communicated to a third party without prior written permission of RADIALL.			
DECIMAL	ANGLE	CHKD:	DATE	SMA STRAIGHT PLUG CRIMP TYPE RG-316 & SIMILAR CABLES			
		J.S.	08/09/12				
		APVD:	DATE	SIZE	FSCM NO.	DWG NO.	REV
		J.M.	08/09/12	A	19505	9101-9573-903	A
REFERENCE:		MATERIALS & FINISHES:		SCALE 5:1		THIRD ANGLE PROJECTION	SHEET 1 OF 1
ORIGINATED: D.N. DATE: 08/09/12		SEE NOTES					

9101-9573-903