

Features

- 3 V, 5 V, ± 5 V specifications
- 3 dB bandwidth: 90 MHz
- Gain bandwidth product: 70 MHz
- Slew rate: 100 V/ μ s (typical for 5 V)
- Output current: up to 55 mA
- Input single supply voltage
- Output rail-to-rail
- Specified for 150 Ω loads
- Low distortion, THD: 0.1 %
- SOT23-5, TSSOP, and SO packages

Applications

- Video buffers
- ADC driver
- Hi-fi applications

Description

The TSH7x series offers single, dual, triple, and quad operational amplifiers featuring high video performances with large bandwidth, low distortion, and excellent supply voltage rejection. Running with a single supply voltage from 3 V to 12 V, these amplifiers feature a large output voltage swing and high output current capable of driving standard 150 Ω loads. A low operating voltage makes TSH7x amplifiers ideal for use in portable equipment. The TSH71, TSH73, and TSH75 also feature standby inputs, each of which allows the op-amp to be put into a standby mode with low-power consumption and high-output impedance. This function allows power saving or signal switching/multiplexing for high-speed applications and video applications. To economize both board space and weight, the TSH7x series is proposed in SOT23-5, SO, and TSSOP packages.

Contents

| | | |
|----------|--|-----------|
| 1 | Typical application: video driver | 3 |
| 2 | Absolute maximum ratings and operating conditions | 4 |
| 3 | Electrical characteristics | 5 |
| 3.1 | Standby mode | 11 |
| 3.2 | Characteristic curves for $V_{CC} = 3\text{ V}$ | 12 |
| 3.3 | Characteristic curves for $V_{CC} = 5\text{ V}$ | 15 |
| 3.4 | Characteristic curves for $V_{CC} = 10\text{ V}$ | 18 |
| 4 | Testing conditions | 21 |
| 4.1 | Layout precautions | 21 |
| 4.2 | Maximum input level | 22 |
| 4.3 | Video capabilities | 22 |
| 4.4 | Precautions when operating on an asymmetrical supply | 24 |
| 5 | Package information | 26 |
| 5.1 | SOT23-5 package information | 27 |
| 5.2 | SO8 package information | 28 |
| 5.3 | TSSOP8 package information | 29 |
| 5.4 | SO14 package information | 30 |
| 5.5 | TSSOP14 package information | 31 |
| 5.6 | SO16 package information | 32 |
| 5.7 | TSSOP16 package information | 33 |
| 6 | Order information | 34 |
| 7 | Revision history | 35 |

1 Typical application: video driver

A typical application for the TSH7x family is that of a video driver for driving STi7xxx DAC outputs on 75-ohm lines.

Figure 1 show the benefits of the TSH7x family as single supply drivers.

Figure 1. Benefits of TSH7x family: +3 V or +5 V single supply solution

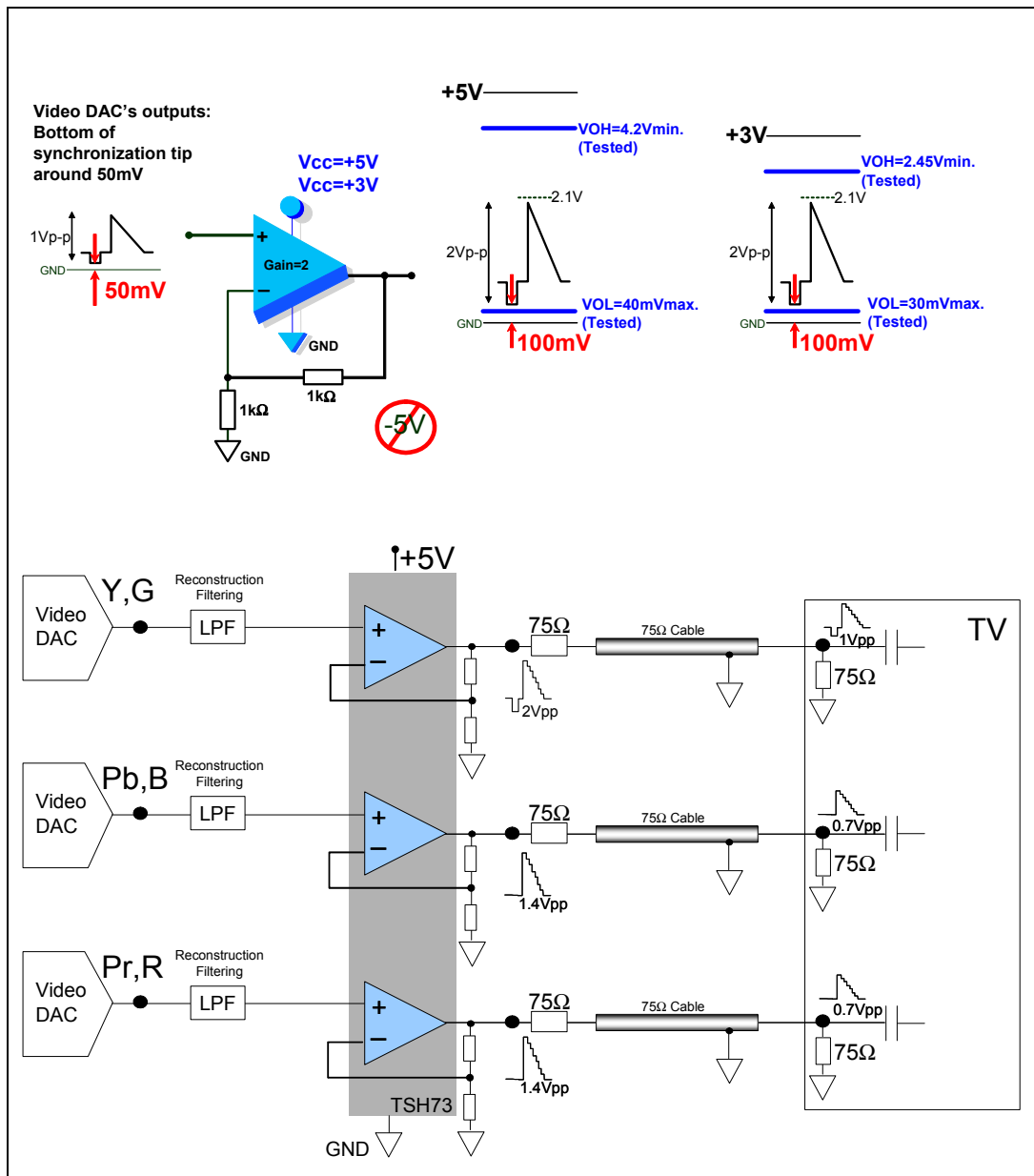

2 Absolute maximum ratings and operating conditions

Table 1. Absolute maximum ratings (AMR)

| Symbol | Parameter | Value | Unit |
|------------|--|-------------|------|
| V_{CC} | Supply Voltage ⁽¹⁾ | 14 | V |
| V_{id} | Differential Input Voltage ⁽²⁾ | ± 2 | |
| V_i | Input Voltage ⁽³⁾ | ± 6 | |
| T_{oper} | Operating Free Air Temperature Range | 0 to +70 | °C |
| T_{stg} | Storage Temperature | -65 to +150 | |
| T_j | Maximum Junction Temperature | 150 | |
| R_{thjc} | Thermal resistance junction to case ⁽⁴⁾ | | °C/W |
| | SOT23-5 | 80 | |
| | SO8 | 28 | |
| | TSSOP08 | 37 | |
| | SO14 | 22 | |
| | TSSOP14 | 32 | |
| | SO16 | 35 | |
| R_{thja} | Thermal resistance junction to ambient area | | °C/W |
| | SOT23-5 | 250 | |
| | SO8 | 157 | |
| | TSSOP08 | 130 | |
| | SO14 | 125 | |
| | TSSOP14 | 110 | |
| | SO16 | 110 | |
| ESD | Human body model | 2 | kV |

1. All voltages values, except differential voltage are with respect to the network ground terminal
2. Differential voltages are the non-inverting input terminal with respect to the inverting terminal
3. The magnitude of the input and output must never exceed $V_{CC} + 0.3V$
4. Short-circuits can cause excessive heating

Table 2. Operating conditions

| Symbol | Parameter | Value | Unit |
|----------|---------------------------------|----------------------------------|------|
| V_{CC} | Supply voltage | 3 to 12 | V |
| V_{IC} | Common mode input voltage range | V_{CC}^- to $(V_{CC}^+ - 1.1)$ | |
| Standby | | (V_{CC}^-) to (V_{CC}^+) | |

3 Electrical characteristics

Table 3. $V_{CC}^+ = 3\text{ V}$, $V_{CC}^- = \text{GND}$, $V_{IC} = 1.5\text{ V}$, $T_{\text{amb}} = 25\text{ }^\circ\text{C}$ (unless otherwise specified)

| Symbol | Parameter | Test conditions | Min. | Typ. | Max. | Unit |
|-----------------|---|--|--|--|-----------|------------------------------|
| $ V_{io} $ | Input offset voltage | $T_{\text{amb}} = 25\text{ }^\circ\text{C}$ $T_{\text{min.}} < T_{\text{amb}} < T_{\text{max.}}$ | | 1.2 | 10 12 | mV |
| ΔV_{io} | Input offset voltage drift vs. temp. | $T_{\text{min.}} < T_{\text{amb}} < T_{\text{max.}}$ | | 4 | | $\mu\text{V}/^\circ\text{C}$ |
| I_{io} | Input offset current | $T_{\text{amb}} = 25\text{ }^\circ\text{C}$ $T_{\text{min.}} < T_{\text{amb}} < T_{\text{max.}}$ | | 0.1 | 3.5 5 | μA |
| I_{ib} | Input bias current | $T_{\text{amb}} = 25\text{ }^\circ\text{C}$ $T_{\text{min.}} < T_{\text{amb}} < T_{\text{max.}}$ | | 6 | 15 20 | |
| C_{in} | Input capacitance | | | 0.2 | | pF |
| I_{CC} | Supply current per operator | $T_{\text{amb}} = 25\text{ }^\circ\text{C}$ $T_{\text{min.}} < T_{\text{amb}} < T_{\text{max.}}$ | | 7.2 | 9.8 11 | mA |
| CMRR | Common mode rejection ratio ($\delta V_{IC}/\delta V_{io}$) | $+0.1 < V_{IC} < +1.9\text{ V}$ and $V_{out} = 1.5\text{ V}$ $T_{\text{amb}} = 25\text{ }^\circ\text{C}$ $T_{\text{min.}} < T_{\text{amb}} < T_{\text{max.}}$ | 65 64 | 90 | | dB |
| SVRR | Supply voltage rejection ratio ($\delta V_{CC}/\delta V_{io}$) | $T_{\text{amb}} = 25\text{ }^\circ\text{C}$ $T_{\text{min.}} < T_{\text{amb}} < T_{\text{max.}}$ | 66 65 | 74 | | |
| PSRR | Power supply rejection ratio ($\delta V_{CC}/\delta V_{out}$) | Positive and negative rail | | 75 | | |
| A_{vd} | Large signal voltage gain | $R_L = 150\ \Omega$ to 1.5 V , $V_{out} = 1\text{ V}$ to 2 V $T_{\text{amb}} = 25\text{ }^\circ\text{C}$ $T_{\text{min.}} < T_{\text{amb}} < T_{\text{max.}}$ | 70 65 | 81 | | |
| I_o | Output short circuit current source | $T_{\text{amb}} = 25\text{ }^\circ\text{C}$, $V_{id} = +1$, V_{out} to 1.5 V , $V_{id} = -1$, V_{out} to 1.5 V I_{Source} I_{Sink} $T_{\text{min.}} < T_{\text{amb}} < T_{\text{max.}}$, $V_{id} = +1$, V_{out} to 1.5 V , $V_{id} = -1$, V_{out} to 1.5 V I_{Source} I_{Sink} | 30 20 22 19 | 43 33 | | mA |
| V_{OH} | High level output voltage | $T_{\text{amb}} = 25\text{ }^\circ\text{C}$ $R_L = 150\ \Omega$ to GND $R_L = 600\ \Omega$ to GND $R_L = 2\text{ k}\Omega$ to GND $R_L = 10\text{ k}\Omega$ to GND $R_L = 150\ \Omega$ to 1.5 V $R_L = 600\ \Omega$ to 1.5 V $R_L = 2\text{ k}\Omega$ to 1.5 V $R_L = 10\text{ k}\Omega$ to 1.5 V $T_{\text{min.}} < T_{\text{amb}} < T_{\text{max.}}$ $R_L = 150\ \Omega$ to GND $R_L = 150\ \Omega$ to 1.5 V | 2.45 2.65 2.4 2.6 | 2.60 2.87 2.91 2.93 2.77 2.90 2.92 2.93 | | V |

Table 3. $V_{CC}^+ = 3\text{ V}$, $V_{CC}^- = \text{GND}$, $V_{IC} = 1.5\text{ V}$, $T_{\text{amb}} = 25\text{ }^\circ\text{C}$ (unless otherwise specified) (continued)

| Symbol | Parameter | Test conditions | Min. | Typ. | Max. | Unit |
|------------|--------------------------------------|--|------|-----------------------|-----------|------------------------|
| V_{OL} | Low level output voltage | $T_{\text{amb}} = 25\text{ }^\circ\text{C}$ $R_L = 150\ \Omega$ to GND $R_L = 600\ \Omega$ to GND $R_L = 2\ \text{k}\Omega$ to GND $R_L = 10\ \text{k}\Omega$ to GND | | 10 11 11 11 | 30 | mV |
| | | $R_L = 150\ \Omega$ to 1.5 V $R_L = 600\ \Omega$ to 1.5 V $R_L = 2\ \text{k}\Omega$ to 1.5 V $R_L = 10\ \text{k}\Omega$ to 1.5 V | | 140 90 68 57 | 300 | |
| | | $T_{\text{min.}} < T_{\text{amb}} < T_{\text{max.}}$ $R_L = 150\ \Omega$ to GND $R_L = 150\ \Omega$ to 1.5 V | | | 40 350 | |
| GBP | Gain bandwidth product | $F = 10\ \text{MHz}$ $A_{VCL} = +11$ $A_{VCL} = -10$ | | 65 55 | | MHz |
| Bw | Bandwidth @-3dB | $A_{VCL}=+1$, $R_L=150\ \Omega$ to 1.5 V | | 87 | | |
| SR | Slew rate | $A_{VCL}=+2$, $R_L=150\ \Omega // C_L$ to 1.5 V $C_L = 5\ \text{pF}$ $C_L = 30\ \text{pF}$ | 45 | 80 85 | | V/ μs |
| ϕ_m | Phase margin | $R_L=150\ \Omega // 30\ \text{pF}$ to 1.5 V | | 40 | | $^\circ$ |
| en | Equivalent input noise voltage | $F=100\ \text{kHz}$ | | 11 | | nV/ $\sqrt{\text{Hz}}$ |
| THD | Total harmonic distortion | $A_{VCL} = +2$, $F = 4\ \text{MHz}$, $R_L=150\ \Omega // 30\text{pF}$ to 1.5 V $V_{\text{out}} = 1\ \text{V}_{\text{pp}}$ $V_{\text{out}} = 2\ \text{V}_{\text{pp}}$ | | -61 -54 | | dB |
| IM2 | Second order intermodulation product | $A_{VCL} = +2$, $V_{\text{out}} = 2\ \text{V}_{\text{pp}}$ $R_L = 150\ \Omega$ to 1.5 V $F_{\text{in}1} = 180\ \text{kHz}$, $F_{\text{in}2} = 280\ \text{kHz}$ spurious measurements @100 kHz | | -76 | | dBc |
| IM3 | Third order inter modulation product | $A_{VCL} = +2$, $V_{\text{out}} = 2\ \text{V}_{\text{pp}}$ $R_L = 150\ \Omega$ to 1.5 V $F_{\text{in}1} = 180\text{kHz}$, $F_{\text{in}2} = 280\ \text{kHz}$ spurious measurements @400 kHz | | -68 | | |
| ΔG | Differential gain | $A_{VCL}=+2$, $R_L = 150\ \Omega$ to 1.5 V $F = 4.5\ \text{MHz}$, $V_{\text{out}} = 2\ \text{V}_{\text{pp}}$ | | 0.5 | | % |
| Df | Differential phase | $A_{VCL} = +2$, $R_L = 150\ \Omega$ to 1.5 V $F = 4.5\ \text{MHz}$, $V_{\text{out}} = 2\ \text{V}_{\text{pp}}$ | | 0.5 | | $^\circ$ |
| Gf | Gain flatness | $F = \text{DC to } 6\ \text{MHz}$, $A_{VCL} = +2$ | | 0.2 | | dB |
| Vo1/Vo2 | Channel separation | $F = 1\ \text{MHz to } 10\ \text{MHz}$ | | 65 | | |

Table 4. $V_{CC}^+ = 5\text{ V}$, $V_{CC}^- = \text{GND}$, $V_{IC} = 2.5\text{ V}$, $T_{\text{amb}} = 25\text{ }^\circ\text{C}$ (unless otherwise specified)

| Symbol | Parameter | Test conditions | Min. | Typ. | Max. | Unit |
|-----------------|---|--|---|--|--------------|------------------------------|
| $ V_{io} $ | Input offset voltage | $T_{\text{amb}} = 25\text{ }^\circ\text{C}$ $T_{\text{min.}} < T_{\text{amb}} < T_{\text{max.}}$ | | 1.1 | 10 12 | mV |
| ΔV_{io} | Input offset voltage drift vs. temp. | $T_{\text{min.}} < T_{\text{amb}} < T_{\text{max.}}$ | | 3 | | $\mu\text{V}/^\circ\text{C}$ |
| I_{io} | Input offset current | $T_{\text{amb}} = 25\text{ }^\circ\text{C}$ $T_{\text{min.}} < T_{\text{amb}} < T_{\text{max.}}$ | | 0.1 | 3.5 5 | μA |
| I_{ib} | Input bias current | $T_{\text{amb}} = 25\text{ }^\circ\text{C}$ $T_{\text{min.}} < T_{\text{amb}} < T_{\text{max.}}$ | | 6 | 15 20 | |
| C_{in} | Input capacitance | | | 0.3 | | pF |
| I_{CC} | Supply current per operator | $T_{\text{amb}} = 25\text{ }^\circ\text{C}$ $T_{\text{min.}} < T_{\text{amb}} < T_{\text{max.}}$ | | 8.2 | 10.5 11.5 | mA |
| CMRR | Common mode rejection ratio ($\delta V_{IC}/\delta V_{io}$) | $+0.1 < V_{IC} < 3.9\text{ V}$ and $V_{out} = 2.5\text{ V}$ $T_{\text{amb}} = 25\text{ }^\circ\text{C}$ $T_{\text{min.}} < T_{\text{amb}} < T_{\text{max.}}$ | 72 71 | 97 | | dB |
| SVRR | Supply voltage rejection ratio ($\delta V_{CC}/\delta V_{io}$) | $T_{\text{amb}} = 25\text{ }^\circ\text{C}$ $T_{\text{min.}} < T_{\text{amb}} < T_{\text{max.}}$ | 68 67 | 75 | | |
| PSRR | Power supply rejection ratio ($\delta V_{CC}/\delta V_{out}$) | Positive and negative rail | | 75 | | |
| A_{vd} | Large signal voltage gain | $R_L = 150\ \Omega$ to 1.5 V , $V_{out} = 1\text{ V}$ to 4 V $T_{\text{amb}} = 25\text{ }^\circ\text{C}$ $T_{\text{min.}} < T_{\text{amb}} < T_{\text{max.}}$ | 75 70 | 84 | | |
| I_o | Output short circuit current source | $T_{\text{amb}} = 25\text{ }^\circ\text{C}$, $V_{id} = +1$, V_{out} to 1.5 V , $V_{id} = -1$, V_{out} to 1.5 V I_{Source} I_{Sink} $T_{\text{min.}} < T_{\text{amb}} < T_{\text{max.}}$ $V_{id} = +1$, V_{out} to 1.5 V $V_{id} = -1$, V_{out} to 1.5 V I_{Source} I_{Sink} | 35 33 34 32 | 55 55 | | mA |
| V_{OH} | High level output voltage | $T_{\text{amb}} = 25\text{ }^\circ\text{C}$ $R_L = 150\ \Omega$ to GND $R_L = 600\ \Omega$ to GND $R_L = 2\text{ k}\Omega$ to GND $R_L = 10\text{ k}\Omega$ to GND $R_L = 150\ \Omega$ to 2.5 V $R_L = 600\ \Omega$ to 2.5 V $R_L = 2\text{ k}\Omega$ to 2.5 V $R_L = 10\text{ k}\Omega$ to 2.5 V $T_{\text{min.}} < T_{\text{amb}} < T_{\text{max.}}$ $R_L = 150\ \Omega$ to GND $R_L = 150\ \Omega$ to 2.5 V | 4.2 4.1 4.4 | 4.36 4.85 4.90 4.93 4.66 4.90 4.92 4.93 | | V |

Table 4. $V_{CC}^+ = 5\text{ V}$, $V_{CC}^- = \text{GND}$, $V_{IC} = 2.5\text{ V}$, $T_{\text{amb}} = 25\text{ }^\circ\text{C}$ (unless otherwise specified) (continued)

| Symbol | Parameter | Test conditions | Min. | Typ. | Max. | Unit |
|------------|--------------------------------------|---|------|------------------------|-----------|------------------------|
| V_{OL} | Low level output voltage | $T_{\text{amb}} = 25\text{ }^\circ\text{C}$ $R_L = 150\ \Omega$ to GND $R_L = 600\ \Omega$ to GND $R_L = 2\text{ k}\Omega$ to GND $R_L = 10\text{ k}\Omega$ to GND | | 20 23 23 23 | 40 | mV |
| | | $R_L = 150\ \Omega$ to 2.5 V $R_L = 600\ \Omega$ to 2.5 V $R_L = 2\text{ k}\Omega$ to 2.5 V $R_L = 10\text{ k}\Omega$ to 2.5 V | | 220 105 76 61 | 400 | |
| | | $T_{\text{min.}} < T_{\text{amb}} < T_{\text{max.}}$ $R_L = 150\ \Omega$ to GND $R_L = 150\ \Omega$ to 2.5 V | | | 60 450 | |
| GBP | Gain bandwidth product | $F = 10\text{ MHz}$ $A_{VCL} = +11$ $A_{VCL} = -10$ | | 65 55 | | MHz |
| Bw | Bandwidth @-3 dB | $A_{VCL} = +1$, $R_L = 150\ \Omega$ to 2.5 V | | 87 | | |
| SR | Slew rate | $A_{VCL} = +2$, $R_L = 150\ \Omega // C_L$ to 2.5 V $C_L = 5\text{ pF}$ $C_L = 30\text{ pF}$ | 60 | 104 105 | | V/ μs |
| ϕ_m | Phase margin | $R_L = 150\ \Omega // 30\text{ pF}$ to 2.5 V | | 40 | | $^\circ$ |
| en | Equivalent input noise voltage | $F = 100\text{ kHz}$ | | 11 | | nV/ $\sqrt{\text{Hz}}$ |
| THD | Total harmonic distortion | $A_{VCL} = +2$, $F = 4\text{ MHz}$ $R_L = 150\ \Omega // 30\text{ pF}$ to 2.5 V $V_{\text{out}} = 1\text{ Vpp}$ $V_{\text{out}} = 2\text{ Vpp}$ | | -61 -54 | | dB |
| IM2 | Second order intermodulation product | $A_{VCL} = +2$, $V_{\text{out}} = 2\text{ Vpp}$ $R_L = 150\ \Omega$ to 2.5 V $F_{\text{in}1} = 180\text{ kHz}$, $F_{\text{in}2} = 280\text{ kHz}$ spurious measurements @100 kHz | | -76 | | dBc |
| IM3 | Third order inter modulation product | $A_{VCL} = +2$, $V_{\text{out}} = 2\text{ Vpp}$ $R_L = 150\ \Omega$ to 2.5 V $F_{\text{in}1} = 180\text{ kHz}$, $F_{\text{in}2} = 280\text{ kHz}$ spurious measurements @400 kHz | | -68 | | |
| ΔG | Differential gain | $A_{VCL} = +2$, $R_L = 150\ \Omega$ to 2.5 V $F = 4.5\text{ MHz}$, $V_{\text{out}} = 2\text{ Vpp}$ | | 0.5 | | % |
| Df | Differential phase | $A_{VCL} = +2$, $R_L = 150\ \Omega$ to 2.5 V $F = 4.5\text{ MHz}$, $V_{\text{out}} = 2\text{ Vpp}$ | | 0.5 | | $^\circ$ |
| Gf | Gain flatness | $F = \text{DC to } 6\text{ MHz}$, $A_{VCL} = +2$ | | 0.2 | | dB |
| Vo1/Vo2 | Channel separation | $F = 1\text{ MHz to } 10\text{ MHz}$ | | 65 | | |

Table 5. $V_{CC}^+ = 5\text{ V}$, $V_{CC}^- = -5\text{ V}$, $V_{IC} = \text{GND}$, $T_{\text{amb}} = 25\text{ }^\circ\text{C}$ (unless otherwise specified)

| Symbol | Parameter | Test conditions | Min. | Typ. | Max. | Unit |
|-----------------|---|---|--------------------------|---------------------------------|--------------|------------------------------|
| $ V_{io} $ | Input offset voltage | $T_{\text{amb}} = 25\text{ }^\circ\text{C}$ $T_{\text{min.}} < T_{\text{amb}} < T_{\text{max.}}$ | | 0.8 | 10 12 | mV |
| ΔV_{io} | Input offset voltage drift vs. temp. | $T_{\text{min.}} < T_{\text{amb}} < T_{\text{max.}}$ | | 2 | | $\mu\text{V}/^\circ\text{C}$ |
| I_{io} | Input offset current | $T_{\text{amb}} = 25\text{ }^\circ\text{C}$ $T_{\text{min.}} < T_{\text{amb}} < T_{\text{max.}}$ | | 0.1 | 3.5 5 | μA |
| I_{ib} | Input bias current | $T_{\text{amb}} = 25\text{ }^\circ\text{C}$ $T_{\text{min.}} < T_{\text{amb}} < T_{\text{max.}}$ | | 6 | 15 20 | |
| C_{in} | Input capacitance | | | 0.7 | | pF |
| I_{CC} | Supply current per operator | $T_{\text{amb}} = 25\text{ }^\circ\text{C}$ $T_{\text{min.}} < T_{\text{amb}} < T_{\text{max.}}$ | | 9.8 | 12.3 13.4 | mA |
| CMRR | Common mode rejection ratio ($\delta V_{IC}/\delta V_{io}$) | $-4.9 < V_{IC} < 3.9\text{ V}$ and $V_{out} = \text{GND}$ $T_{\text{amb}} = 25\text{ }^\circ\text{C}$ $T_{\text{min.}} < T_{\text{amb}} < T_{\text{max.}}$ | 81 80 | 106 | | dB |
| SVRR | Supply voltage rejection ratio ($\delta V_{CC}/\delta V_{io}$) | $T_{\text{amb}} = 25\text{ }^\circ\text{C}$ $T_{\text{min.}} < T_{\text{amb}} < T_{\text{max.}}$ | 71 70 | 77 | | |
| PSRR | Power supply rejection ratio ($\delta V_{CC}/\delta V_{out}$) | Positive and negative rail | | 75 | | |
| A_{vd} | Large signal voltage gain | $R_L = 150\ \Omega$ to GND $V_{out} = -4$ to $+4$ $T_{\text{amb}} = 25\text{ }^\circ\text{C}$ $T_{\text{min.}} < T_{\text{amb}} < T_{\text{max.}}$ | 75 70 | 86 | | |
| I_o | Output short circuit current source | $T_{\text{amb}} = 25\text{ }^\circ\text{C}$ $V_{id} = +1$, V_{out} to 1.5 V $V_{id} = -1$, V_{out} to 1.5 V I_{Source} I_{Sink} $T_{\text{min.}} < T_{\text{amb}} < T_{\text{max.}}$ $V_{id} = +1$, V_{out} to 1.5 V $V_{id} = -1$, V_{out} to 1.5 V I_{Source} I_{Sink} | 35 30 34 29 | 55 55 | | mA |
| V_{OH} | High level output voltage | $T_{\text{amb}} = 25\text{ }^\circ\text{C}$ $R_L = 150\ \Omega$ to GND $R_L = 600\ \Omega$ to GND $R_L = 2\text{ k}\Omega$ to GND $R_L = 10\text{ k}\Omega$ to GND $T_{\text{min.}} < T_{\text{amb}} < T_{\text{max.}}$ $R_L = 150\ \Omega$ to GND | 4.2 4.1 | 4.36 4.85 4.9 4.93 | | V |
| V_{OL} | Low level output voltage | $T_{\text{amb}} = 25\text{ }^\circ\text{C}$ $R_L = 150\ \Omega$ to GND $R_L = 600\ \Omega$ to GND $R_L = 2\text{ k}\Omega$ to GND $R_L = 10\text{ k}\Omega$ to GND $T_{\text{min.}} < T_{\text{amb}} < T_{\text{max.}}$ $R_L = 150\ \Omega$ to GND | | -4.63 -4.86 -4.9 -4.93 | -4.4 | V |
| | | | | | -4.3 | |

Table 5. $V_{CC}^+ = 5\text{ V}$, $V_{CC}^- = -5\text{ V}$, $V_{IC} = \text{GND}$, $T_{\text{amb}} = 25\text{ }^\circ\text{C}$ (unless otherwise specified) (continued)

| Symbol | Parameter | Test conditions | Min. | Typ. | Max. | Unit |
|------------|--------------------------------------|---|------|------------|------|------------------------|
| GBP | Gain bandwidth product | $F = 10\text{ MHz}$ $A_{VCL} = +11$ $A_{VCL} = -10$ | | 65 55 | | MHz |
| Bw | Bandwidth @-3dB | $A_{VCL} = +1$ $R_L = 150\ \Omega // 30\text{ pF to GND}$ | | 100 | | MHz |
| SR | Slew rate | $A_{VCL} = +2,$ $R_L = 150\ \Omega // C_L \text{ to GND}$ $C_L = 5\text{ pF}$ $C_L = 30\text{ pF}$ | 68 | 117 118 | | V/ μs |
| ϕ_m | Phase margin | $R_L = 150\ \Omega \text{ to GND}$ | | 40 | | $^\circ$ |
| en | Equivalent input noise voltage | $F = 100\text{ kHz}$ | | 11 | | nV/ $\sqrt{\text{Hz}}$ |
| THD | Total harmonic distortion | $A_{VCL} = +2, F = 4\text{ MHz}$ $R_L = 150\ \Omega // 30\text{ pF to GND}$ $V_{\text{out}} = 1\text{ Vpp}$ $V_{\text{out}} = 2\text{ Vpp}$ | | -61 -54 | | dB |
| IM2 | Second order intermodulation product | $A_{VCL} = +2, V_{\text{out}} = 2\text{ Vpp}$ $R_L = 150\ \Omega \text{ to GND}$ $\text{Fin1} = 180\text{ kHz}, \text{Fin2} = 280\text{ kHz}$ spurious measurements @100 kHz | | -76 | | dBc |
| IM3 | Third order intermodulation product | $A_{VCL} = +2, V_{\text{out}} = 2\text{ Vpp}$ $R_L = 150\ \Omega \text{ to GND}$ $\text{Fin1} = 180\text{ kHz}, \text{Fin2} = 280\text{ kHz}$ spurious measurements @400 kHz | | -68 | | |
| ΔG | Differential gain | $A_{VCL} = +2, R_L = 150\ \Omega \text{ to GND}$ $F = 4.5\text{ MHz}, V_{\text{out}} = 2\text{ Vpp}$ | | 0.5 | | % |
| Df | Differential phase | $A_{VCL} = +2, R_L = 150\ \Omega \text{ to GND}$ $F = 4.5\text{ MHz}, V_{\text{out}} = 2\text{ Vpp}$ | | 0.5 | | $^\circ$ |
| Gf | Gain flatness | $F = \text{DC to } 6\text{ MHz}, A_{VCL} = +2$ | | 0.2 | | dB |
| Vo1/Vo2 | Channel separation | $F = 1\text{ MHz to } 10\text{ MHz}$ | | 65 | | |

3.1 Standby mode

Table 6. V_{CC}^+ , V_{CC}^- , $T_{amb} = 25\text{ °C}$ (unless otherwise specified)

| Symbol | Parameter | Test conditions | Min. | Typ. | Max. | Unit |
|----------------|---|--|------------------|----------|--------------------|------------------|
| V_{low} | Standby low level | | V_{CC}^- | | $(V_{CC}^- + 0.8)$ | V |
| V_{high} | Standby high level | | $(V_{CC}^- + 2)$ | | (V_{CC}^+) | |
| $I_{CC\ STBY}$ | Current consumption per operator when STANDBY is active | Pin 8 (TSH71) to V_{CC}^- Pin 1, 2 or 3 (TSH73) to V_{CC}^- Pin 8 (TSH75) to V_{CC}^+ Pin 9 (TSH75) to V_{CC}^- | | 20 | 55 | μA |
| Z_{out} | Output impedance (R_{out}/C_{out}) | R_{out} C_{out} | | 10 17 | | M Ω pF |
| T_{on} | Time from standby mode to active mode | | | 2 | | μs |
| T_{off} | Time from active mode to standby mode | Down to $I_{CC\ STBY} = 10\ \mu\text{A}$ | | 10 | | |

Table 7. TSH71 standby function table

| TSH71 standby control pin 8 ($\overline{\text{STBY}}$) | Operator status |
|--|-----------------|
| V_{low} | Standby |
| V_{high} | Active |

Table 8. TSH73 standby function table

| TSH73 standby control | | | Operator status | | |
|---|---|---|-----------------|---------|---------|
| $\overline{\text{Pin 1}}$ (STBY OP1) | $\overline{\text{Pin 2}}$ (STBY OP2) | $\overline{\text{Pin 3}}$ (STBY OP3) | OP1 | OP1 | OP3 |
| V_{low} | x | x | Standby | x | x |
| V_{high} | x | x | Active | x | x |
| x | V_{low} | x | x | Standby | x |
| x | V_{high} | | x | Active | x |
| x | x | V_{low} | x | x | Standby |
| x | x | V_{high} | x | x | Active |

Table 9. TSH75 standby function table

| TSH75 standby control | | Operator status | | | |
|-----------------------|---------------------|-----------------|---------|---------|--------|
| Pin 8 (STBY OP2) | Pin 9 (STBY OP3) | OP1 | OP2 | OP3 | OP4 |
| V_{high} | V_{low} | Active | Standby | Standby | Active |
| V_{high} | V_{high} | | | Active | |
| V_{low} | V_{low} | | Active | Standby | |
| V_{low} | V_{high} | | | Active | |

3.2 Characteristic curves for $V_{CC} = 3\text{ V}$

Figure 2. Closed loop gain and phase vs. frequency (gain = +2, $V_{CC} = \pm 1.5\text{ V}$, $R_L = 150\ \Omega$, $T_{amb} = 25\ ^\circ\text{C}$)

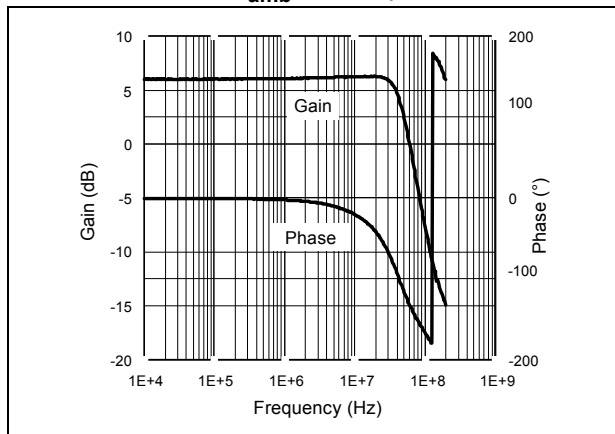

Figure 3. Overshoot function of output capacitance (gain = +2, $V_{CC} = \pm 1.5\text{ V}$, $T_{amb} = 25\ ^\circ\text{C}$)

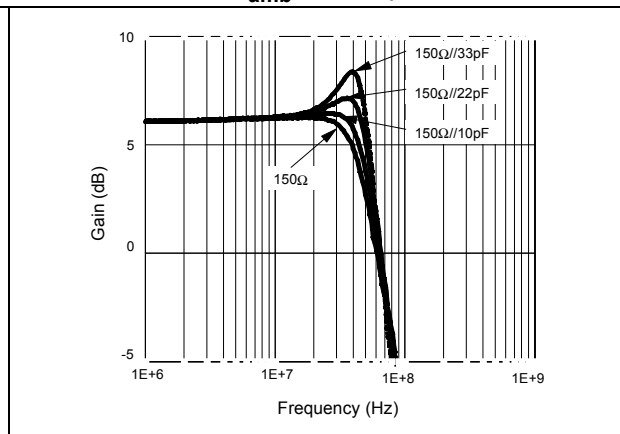

Figure 4. Closed loop gain and phase vs. frequency (gain = -10, $V_{CC} = \pm 1.5\text{ V}$, $R_L = 150\ \Omega$, $T_{amb} = 25\ ^\circ\text{C}$)

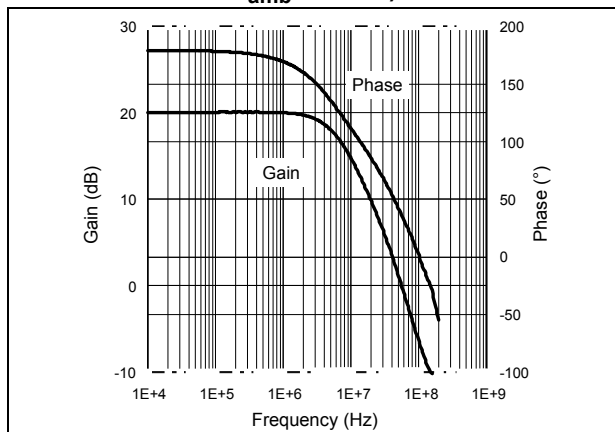

Figure 5. Closed loop gain and phase vs. frequency (gain = +11, $V_{CC} = \pm 1.5\text{ V}$, $R_L = 150\ \Omega$, $T_{amb} = 25\ ^\circ\text{C}$)

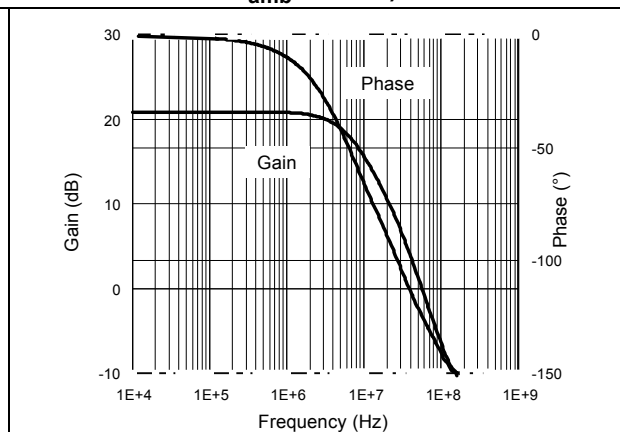

Figure 6. Large signal measurement - positive slew rate (gain = 2, $V_{CC} = \pm 1.5\text{ V}$, $Z_L = 150\ \Omega // 5.6\text{ pF}$)

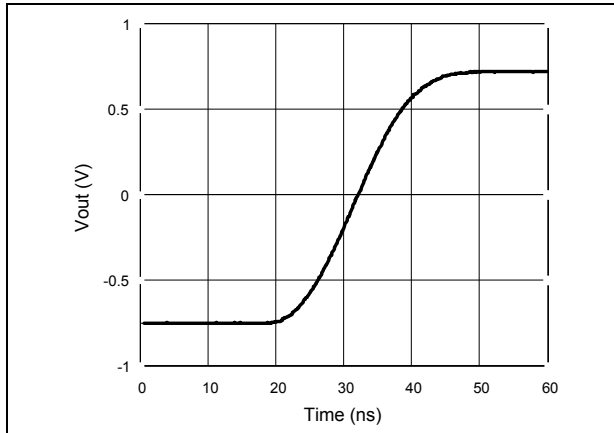

Figure 7. Large signal measurement - negative slew rate (gain = 2, $V_{CC} = \pm 1.5\text{ V}$, $Z_L = 150\ \Omega // 5.6\text{ pF}$)

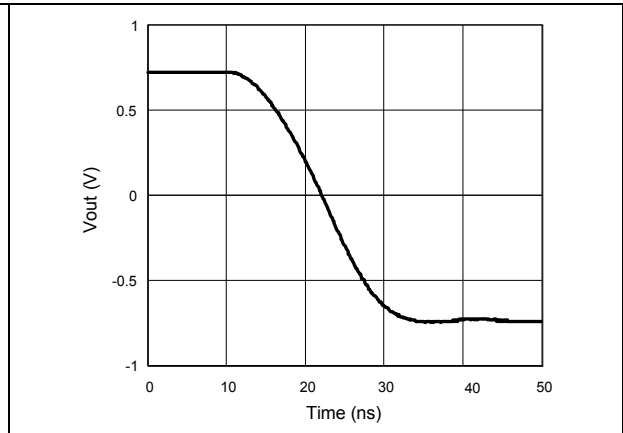

Figure 8. Small signal measurement - rise time (gain = 2, $V_{CC} = \pm 1.5\text{ V}$, $Z_L = 150\ \Omega$)

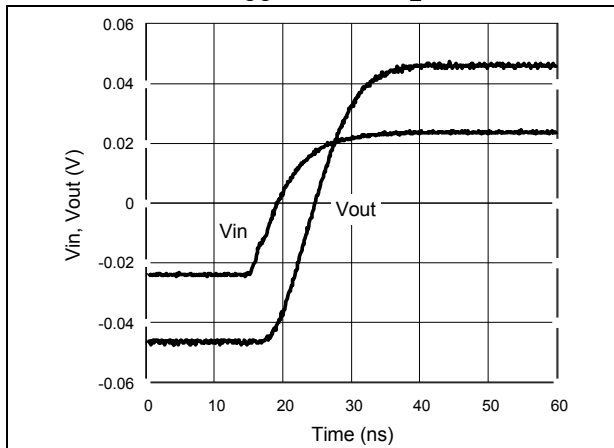

Figure 9. Small signal measurement - fall time (gain = 2, $V_{CC} = \pm 1.5\text{ V}$, $Z_L = 150\ \Omega$)

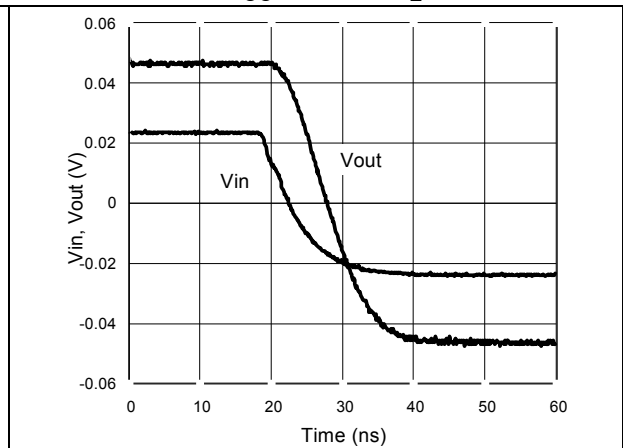

Figure 10. Channel separation (Xtalk) vs. frequency (measurement configuration: Xtalk = $20\ \log(V0/V1)$)

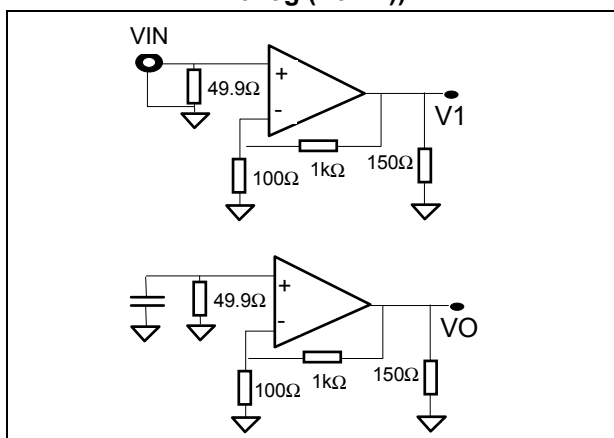

Figure 11. Channel separation (Xtalk) vs. frequency (gain = +11, $V_{CC} = 1.5\text{ V}$, $Z_L = 150\ \Omega // 27\text{ pF}$)

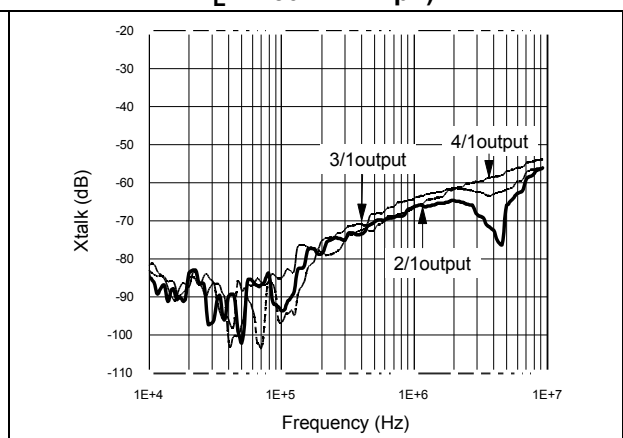

Figure 12. Equivalent noise voltage (gain = 100, $V_{CC} = \pm 1.5$ V, No load)

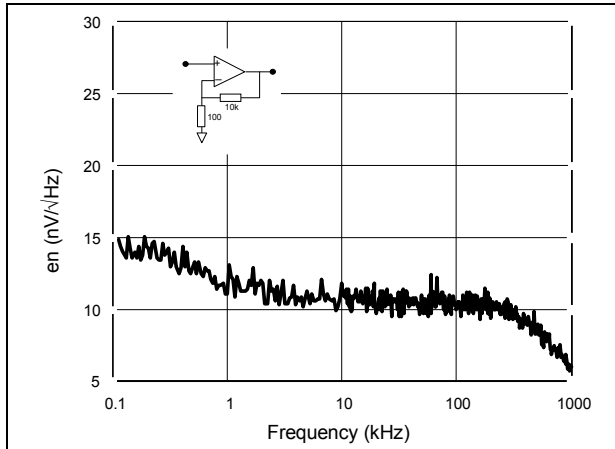

Figure 13. Maximum output swing (gain = 11, $V_{CC} = \pm 5$ V, $R_L = 150 \Omega$)

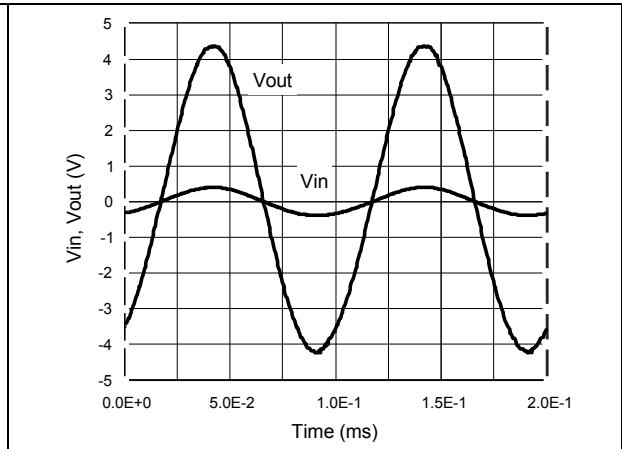

Figure 14. Standby mode - T_{on} , T_{off} ($V_{CC} = \pm 1.5$ V, open loop)

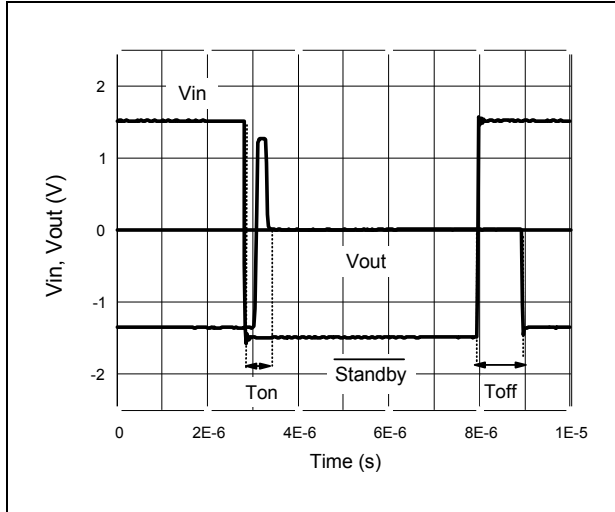

Figure 15. Group delay gain = 2 ($V_{CC} = \pm 1.5$ V, $Z_L = 150 \Omega // 27$ pF, $T_{amb} = 25^\circ C$)

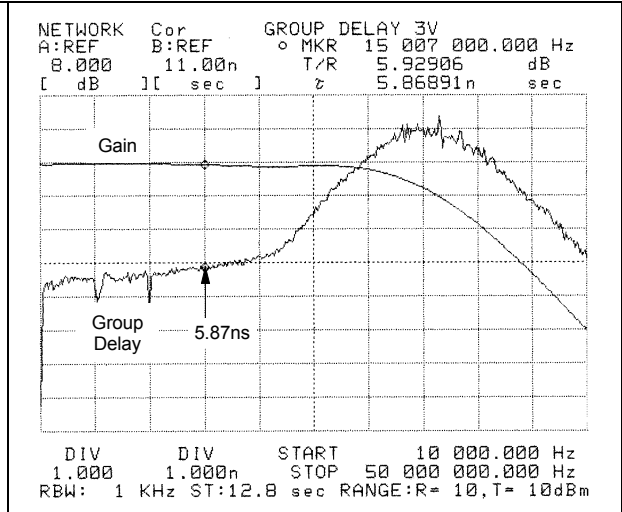
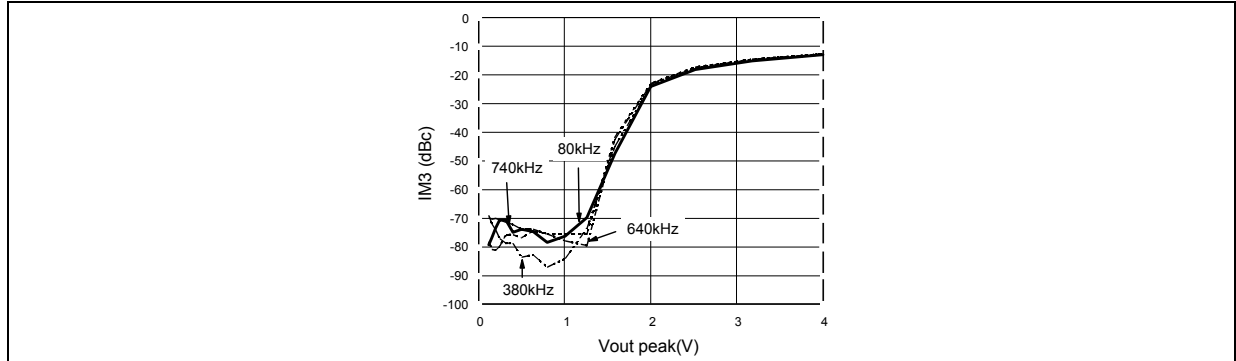

Figure 16. Third order intermodulation (gain = 2, $V_{CC} = \pm 1.5$ V, $Z_L = 150 \Omega // 27$ pF, $T_{amb} = 25^\circ C$)



- Note on intermodulation products:
The IFR2026 synthesizer generates a two tone signal ($F_1 = 180$ kHz, $F_2 = 280$ kHz); each tone has the same amplitude level.
The HP3585 spectrum analyzer measures the intermodulation products function of the output voltage. The generator and the spectrum analyzer are phase locked for precision considerations.

3.3 Characteristic curves for $V_{CC} = 5\text{ V}$

Figure 17. Closed loop gain and phase vs. frequency (gain = +2, $V_{CC} = \pm 2.5\text{ V}$, $R_L = 150\ \Omega$, $T_{amb} = 25\text{ }^\circ\text{C}$)

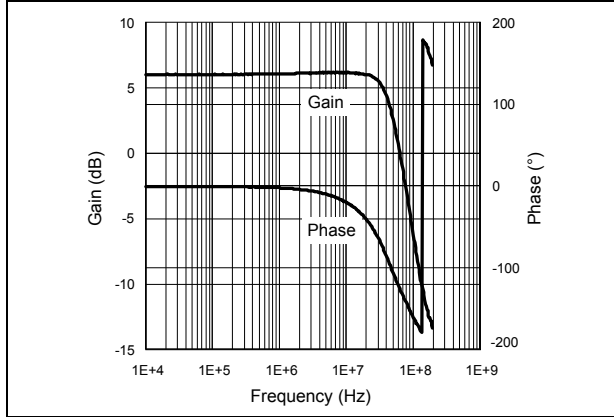

Figure 18. Overshoot function of output capacitance (gain = +2, $V_{CC} = \pm 2.5\text{ V}$, $T_{amb} = 25\text{ }^\circ\text{C}$)

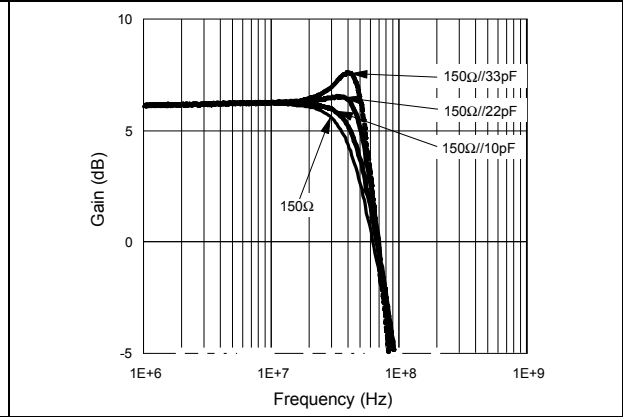

Figure 19. Closed loop gain and phase vs. frequency (gain = -10, $V_{CC} = \pm 2.5\text{ V}$, $R_L = 150\ \Omega$, $T_{amb} = 25\text{ }^\circ\text{C}$)

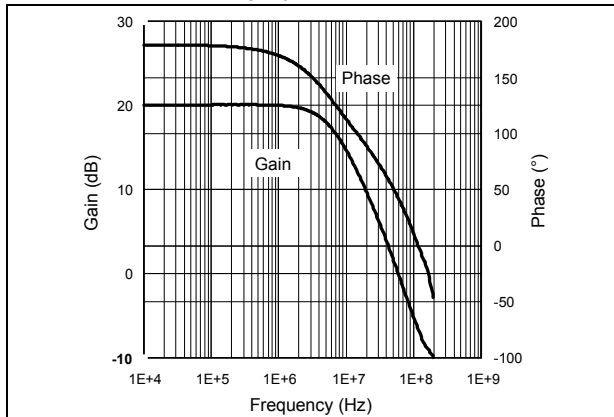

Figure 20. Closed loop gain and phase vs. frequency (gain = +11, $V_{CC} = \pm 2.5\text{ V}$, $R_L = 150\ \Omega$, $T_{amb} = 25\text{ }^\circ\text{C}$)

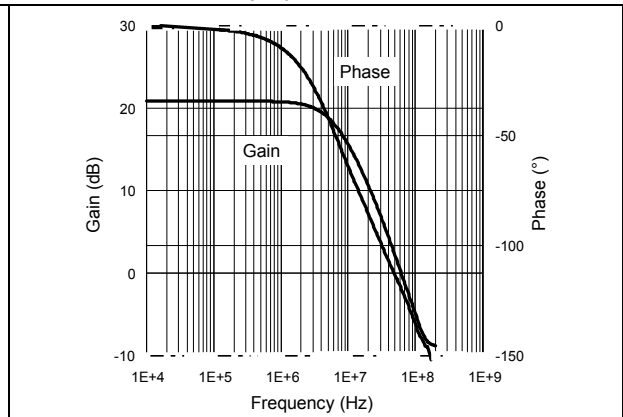

Figure 21. Large signal measurement - positive slew rate (gain = 2, $V_{CC} = \pm 2.5\text{ V}$, $Z_L = 150\ \Omega // 5.6\text{ pF}$)

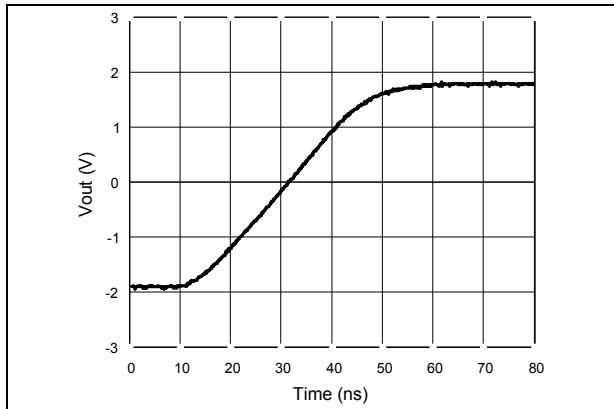

Figure 22. Large signal measurement - negative slew rate (gain = 2, $V_{CC} = \pm 2.5\text{ V}$, $Z_L = 150\ \Omega // 5.6\text{ pF}$)

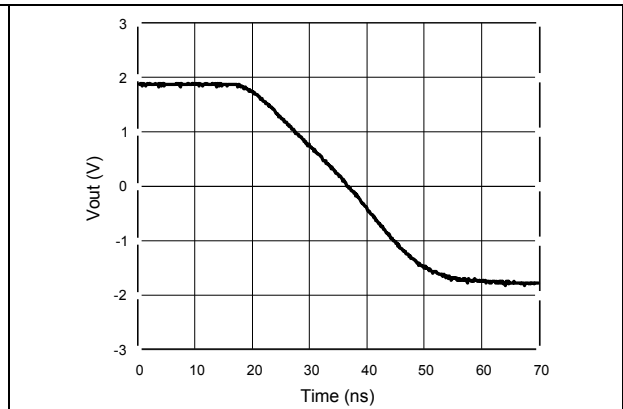

Figure 23. Small signal measurement - rise time (gain = 2, $V_{CC} = \pm 2.5\text{ V}$, $Z_L = 150\ \Omega$)

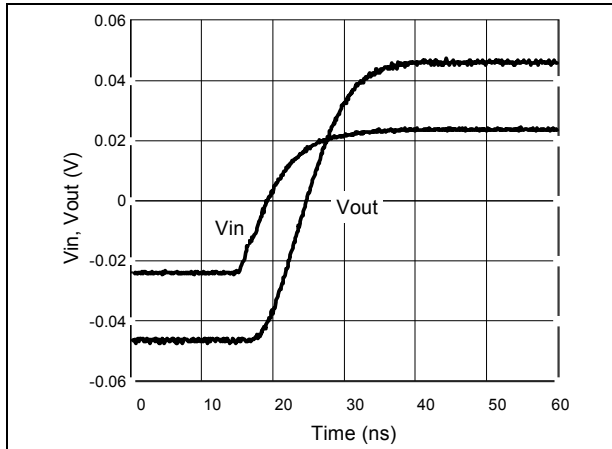

Figure 24. Small signal measurement - fall time (gain = 2, $V_{CC} = \pm 2.5\text{ V}$, $Z_L = 150\ \Omega$)

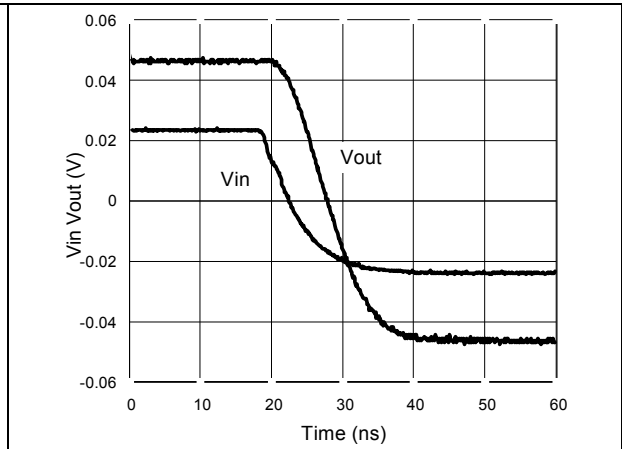

Figure 25. Channel separation (Xtalk) vs. frequency (measurement configuration: $X_{talk} = 20\ \log(V_0/V_1)$)

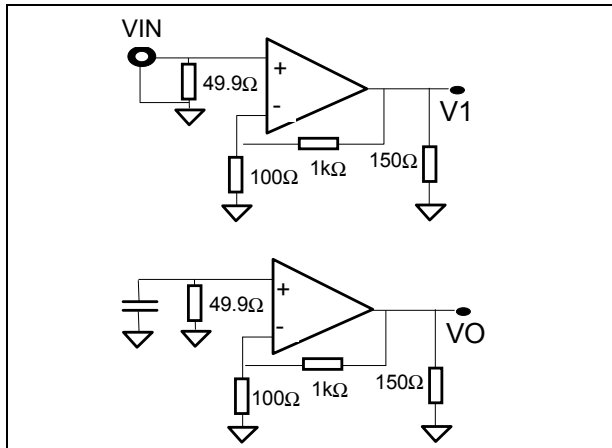

Figure 26. Channel separation (Xtalk) vs. frequency (gain = +11, $V_{CC} = \pm 2.5\text{ V}$, $Z_L = 150\ \Omega // 27\text{ pF}$)

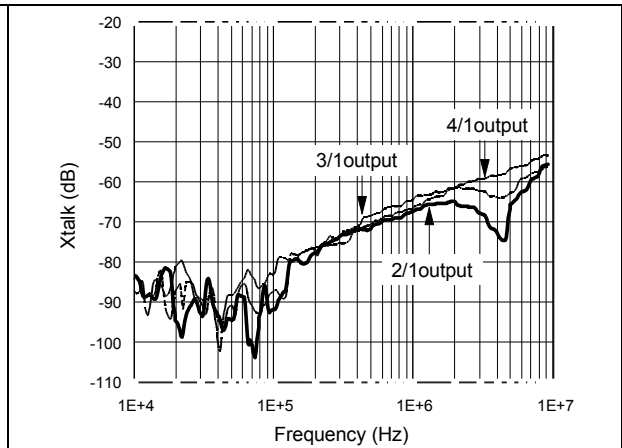

Figure 27. Equivalent noise voltage (gain = 100, $V_{CC} = \pm 2.5\text{ V}$, no load)

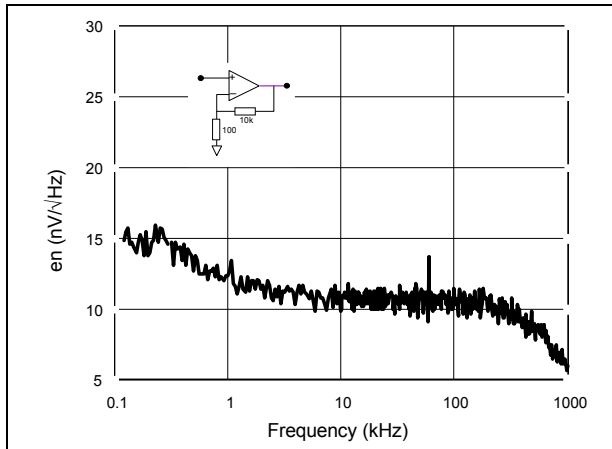

Figure 28. Maximum output swing (gain = 11, $V_{CC} = \pm 2.5\text{ V}$, $R_L = 150\ \Omega$)

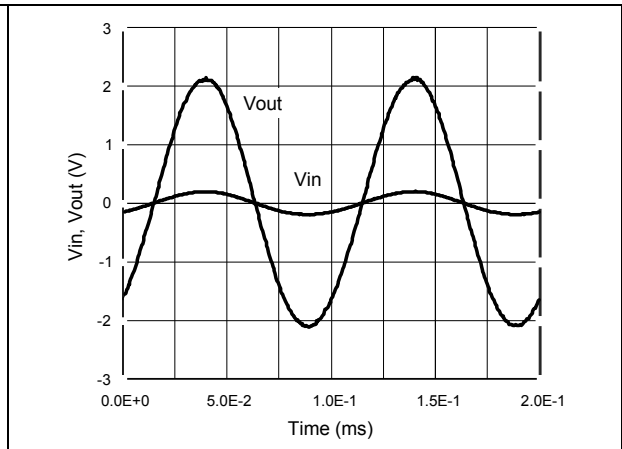

Figure 29. Standby mode - T_{on} , T_{off}
 ($V_{CC} = \pm 2.5\text{ V}$, open loop)

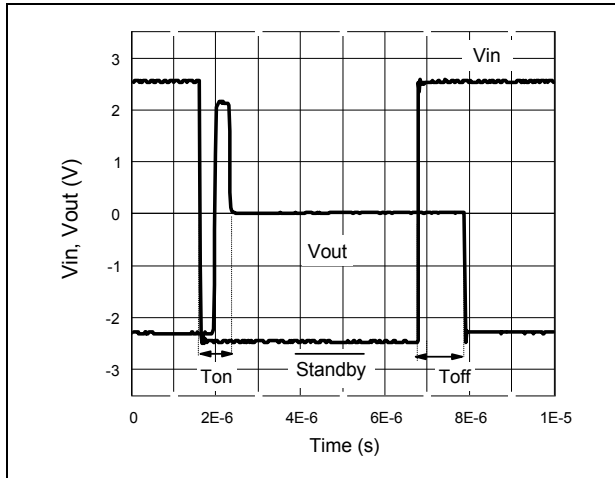

Figure 30. Group delay (gain = 2, $V_{CC} = \pm 2.5\text{ V}$, $Z_L = 150\ \Omega // 27\text{ pF}$, $T_{amb} = 25\text{ }^\circ\text{C}$)

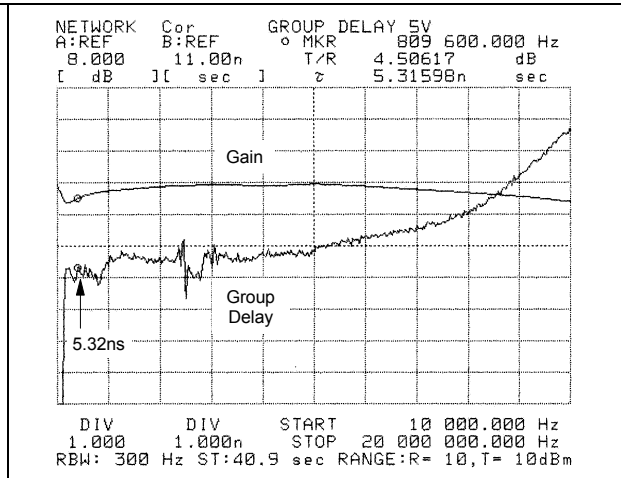
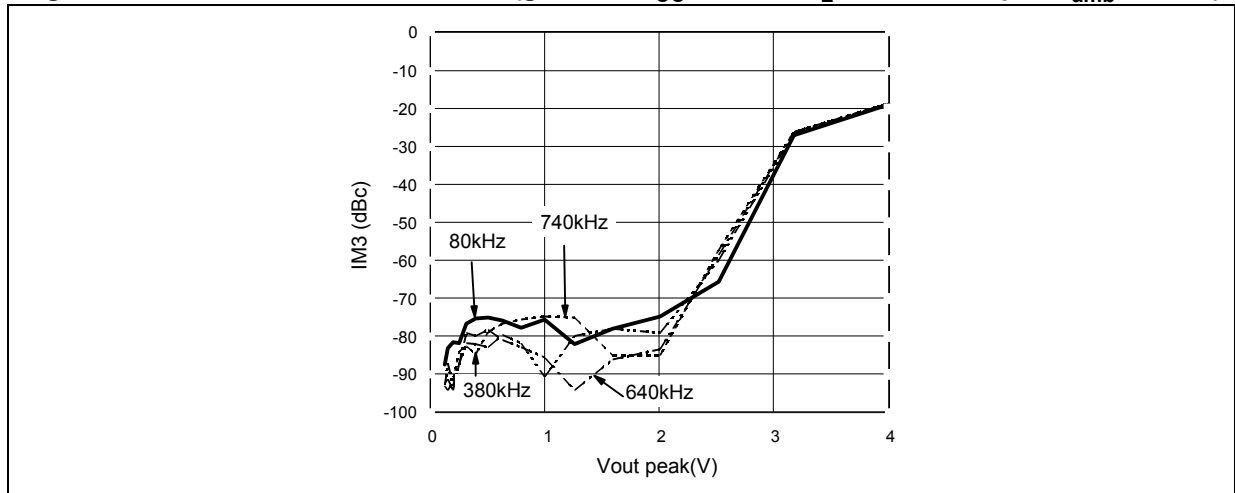

Figure 31. Third order intermodulation (gain = 2, $V_{CC} = \pm 2.5\text{ V}$, $Z_L = 150\ \Omega // 27\text{ pF}$, $T_{amb} = 25\text{ }^\circ\text{C}$)



- Note on intermodulation products:
 The IFR2026 synthesizer generates a two tone signal ($F_1 = 180\text{ kHz}$, $F_2 = 280\text{ kHz}$); each tone has the same amplitude level.
 The HP3585 spectrum analyzer measures the intermodulation products function of the output voltage. The generator and the spectrum analyzer are phase locked for precision considerations.

3.4 Characteristic curves for $V_{CC} = 10\text{ V}$

Figure 32. Closed loop gain and phase vs. frequency (gain = +2, $V_{CC} = \pm 5\text{ V}$, $R_L = 150\ \Omega$, $T_{amb} = 25\text{ }^\circ\text{C}$)

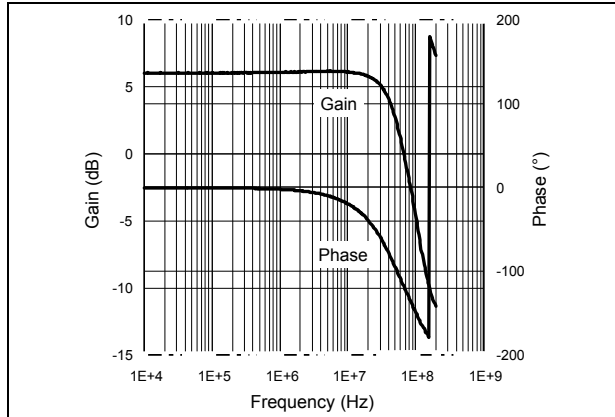

Figure 33. Overshoot function of output capacitance (gain = +2, $V_{CC} = \pm 5\text{ V}$, $T_{amb} = 25\text{ }^\circ\text{C}$)

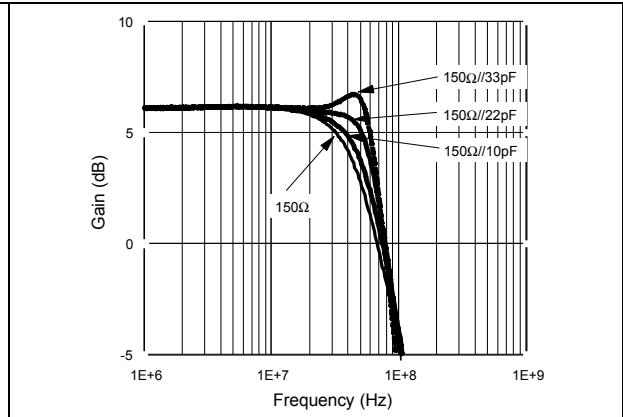

Figure 34. Closed loop gain and phase vs. frequency (gain = -10, $V_{CC} = \pm 5\text{ V}$, $R_L = 150\ \Omega$, $T_{amb} = 25\text{ }^\circ\text{C}$)

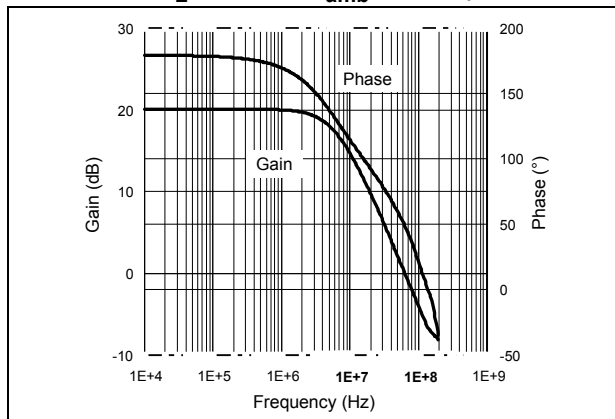

Figure 35. Closed loop gain and phase vs. frequency (gain = +11, $V_{CC} = \pm 5\text{ V}$, $R_L = 150\ \Omega$, $T_{amb} = 25\text{ }^\circ\text{C}$)

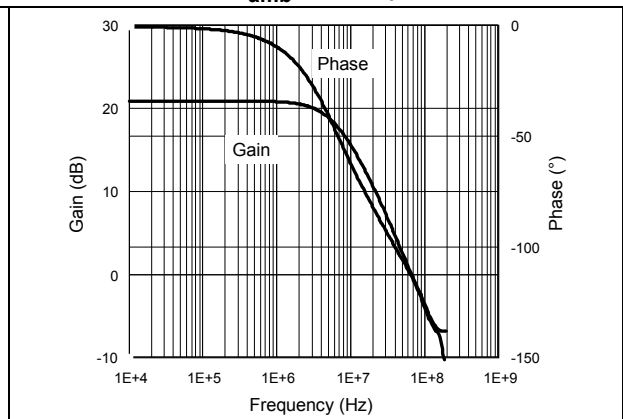

Figure 36. Large signal measurement - positive slew rate (gain = 2, $V_{CC} = \pm 5\text{ V}$, $Z_L = 150\ \Omega // 5.6\text{ pF}$)

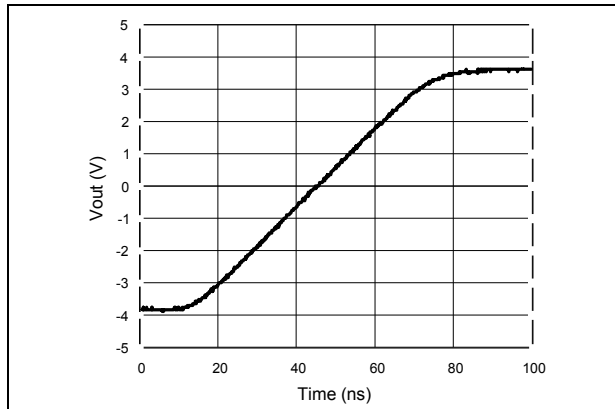

Figure 37. Large signal measurement - negative slew rate (gain = 2, $V_{CC} = \pm 5\text{ V}$, $Z_L = 150\ \Omega // 5.6\text{ pF}$)

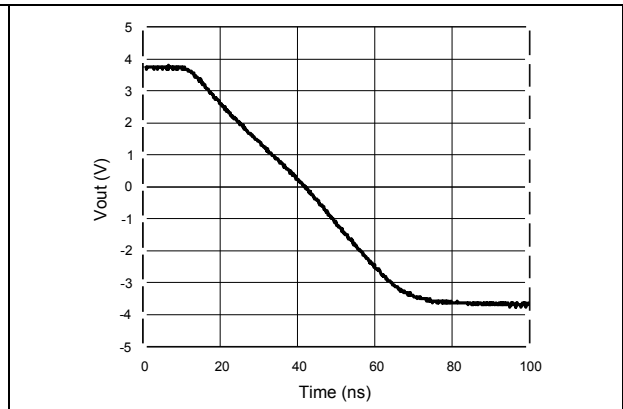

Figure 38. Small signal measurement - rise time
(gain = 2, $V_{CC} = \pm 5\text{ V}$, $Z_L = 150\ \Omega$)

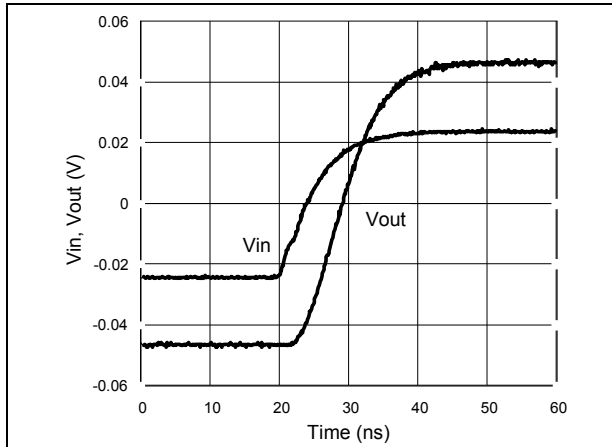

Figure 39. Small signal measurement - fall time
(gain = 2, $V_{CC} = \pm 5\text{ V}$, $Z_L = 150\ \Omega$)

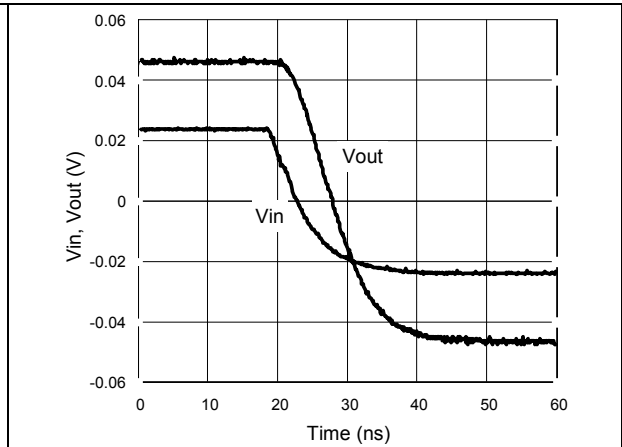

Figure 40. Channel separation (Xtalk) vs. frequency
(measurement configuration: $X_{talk} = 20 \log(V_0/V_1)$)

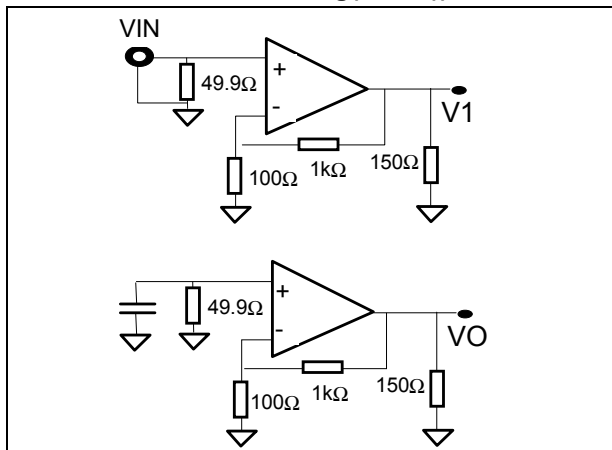

Figure 41. Channel separation (Xtalk) vs. frequency
(gain = +11, $V_{CC} = \pm 5\text{ V}$, $Z_L = 150\ \Omega // 27\text{ pF}$)

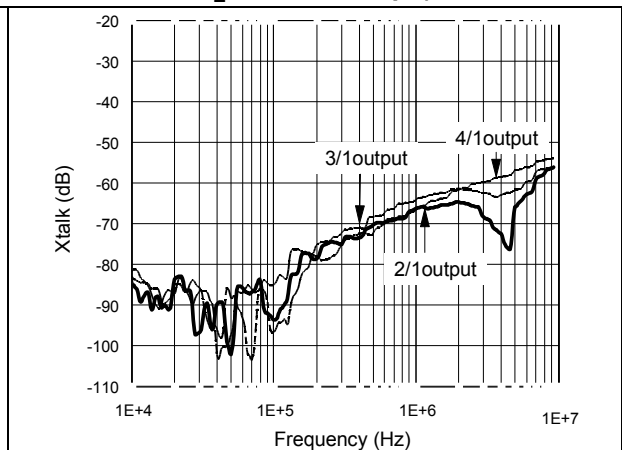

Figure 42. Equivalent noise voltage
(gain = 100, $V_{CC} = \pm 5\text{ V}$, no load)

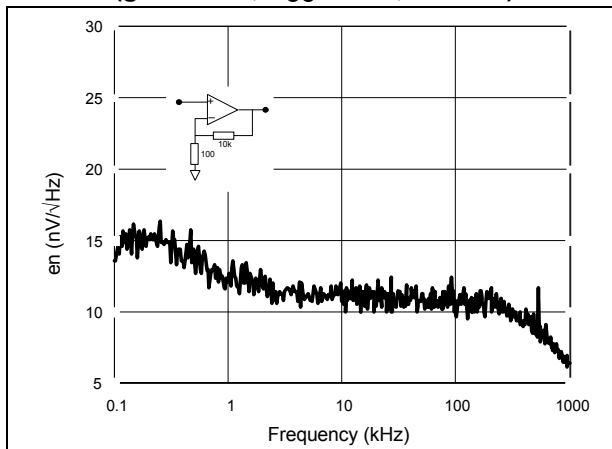

Figure 43. Maximum output swing
(gain = 11, $V_{CC} = \pm 5\text{ V}$, $R_L = 150\ \Omega$)

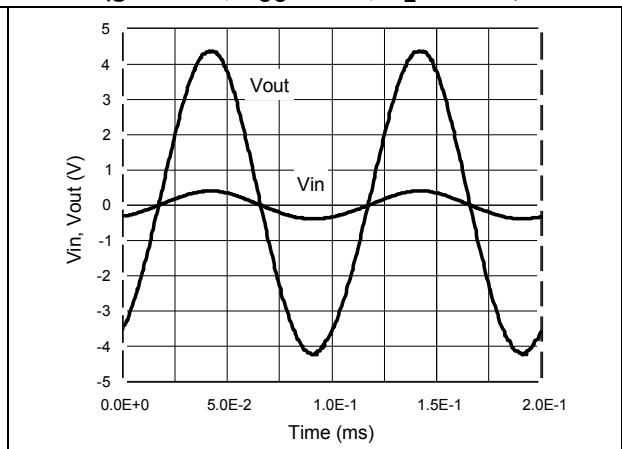

Figure 44. Standby mode - T_{on} , T_{off}
 ($V_{CC} = \pm 5\text{ V}$, open loop)

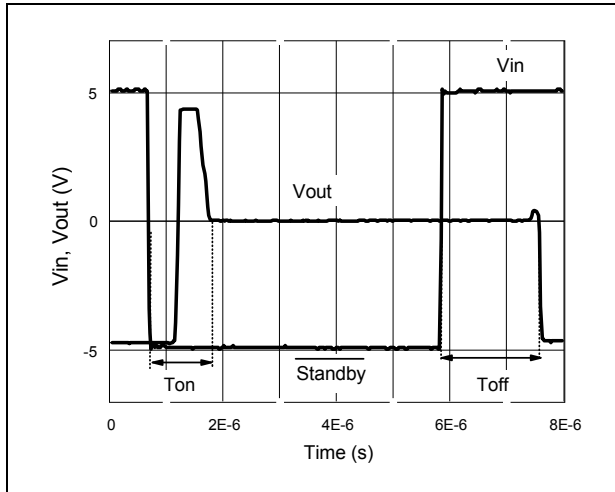

Figure 45. Group delay (gain = 2, $V_{CC} = \pm 5\text{ V}$
 $Z_L = 150\ \Omega // 27\text{ pF}$, $T_{amb} = 25\text{ }^\circ\text{C}$)

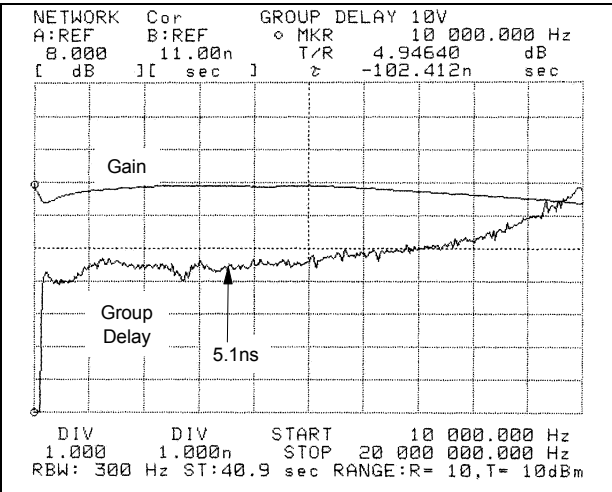
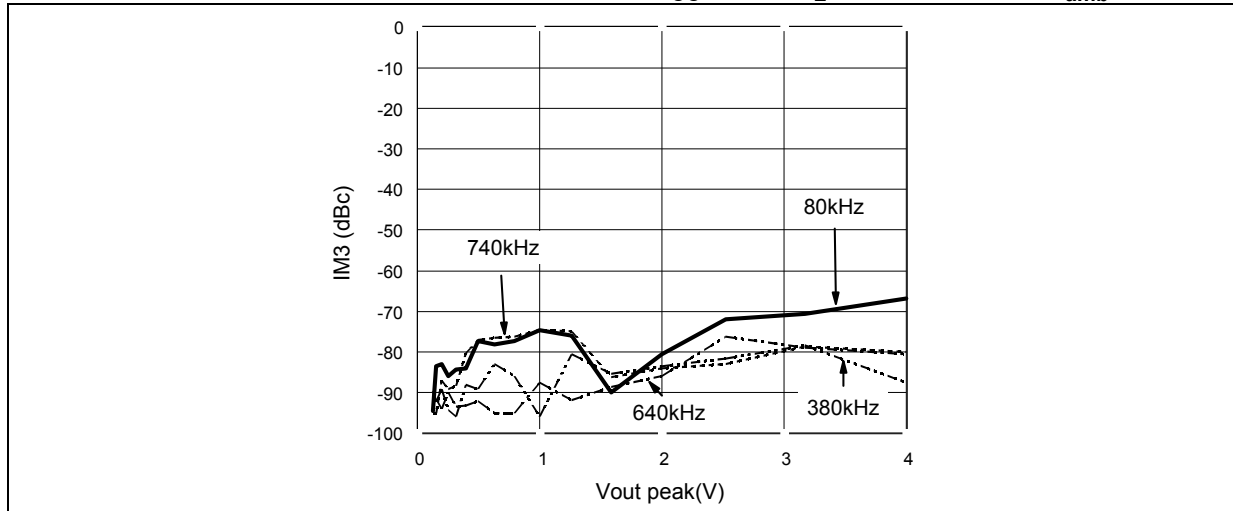

Figure 46. Third order intermodulation (gain = 2, $V_{CC} = \pm 5\text{ V}$, $Z_L = 150\ \Omega // 27\text{ pF}$, $T_{amb} = 25\text{ }^\circ\text{C}$)



- Note on intermodulation products:
 The IFR2026 synthesizer generates a two tone signal ($F_1 = 180\text{ kHz}$, $F_2 = 280\text{ kHz}$); each tone has the same amplitude level.
 The HP3585 spectrum analyzer measures the intermodulation products function of the output voltage. The generator and the spectrum analyzer are phase locked for precision considerations.

4 Testing conditions

4.1 Layout precautions

To use the TSH7X circuits in the best manner at high frequencies, some precautions have to be taken for power supplies:

- First of all, the implementation of a proper ground plane on both sides of the PCB is mandatory for high-speed circuit applications to provide low inductance and low resistance common return.
- Power supply bypass capacitors (4.7 μ F and ceramic 100 pF) should be placed as close as possible to the IC pins in order to improve high frequency bypassing and reduce harmonic distortion. The power supply capacitors must be incorporated for both the negative and the positive pins.
- Proper termination of all inputs and outputs must be in accordance with output termination resistors. In this way, the amplifier load is resistive only, and the stability of the amplifier is improved.
- All leads must be wide and as short as possible (especially for op-amp inputs and outputs) in order to decrease parasitic capacitance and inductance.
- For lower gain applications, care should be taken to avoid large feedback resistance (> 1 k Ω) in order to reduce the time constant of parasitic capacitances.
- Choose component sizes as small as possible (SMD)
- Finally, on output, the load capacitance must be negligible to maintain good stability. You can put a serial resistance as close as possible to the output pin to minimize capacitance.

4.2 Maximum input level

Figure 47. CCIR330 video line

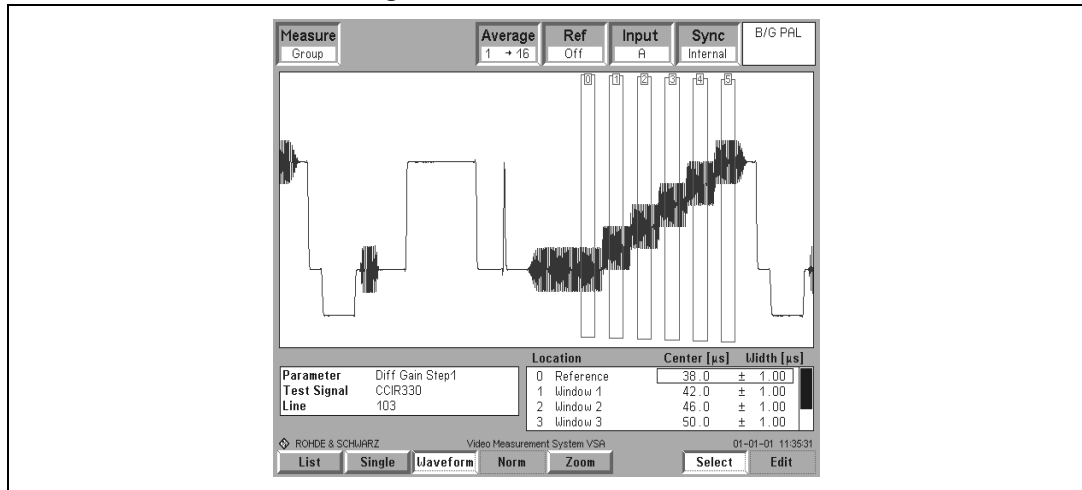

The input level must not exceed the following values:

- Negative peak: must be greater than $-V_{CC}+400$ mV
- Positive peak value: must be lower than $+V_{CC}-400$ mV

The electrical characteristics show the influence of the load on this parameter.

4.3 Video capabilities

To characterize the differential phase and differential gain, a CCIR330 video line is used.

The video line contains five (flat) levels of luma on which is superimposed a chroma signal. The first level contains no luma. The luma gives various amplitudes which define the saturation of the signal. The chrominance gives various phases which define the color of the signal.

Differential phase (respectively differential gain) distortion is present if a signal chrominance phase (gain) is affected by luminance level. They represent the ability to uniformly process the high frequency information at all luminance levels.

When differential gain is present, color saturation is not correctly reproduced.

The input generator is the Rohde and Schwarz CCVS. The output measurement was made by the Rohde and Schwarz VSA.

Figure 48. Measurement on Rohde and Schwarz VSA

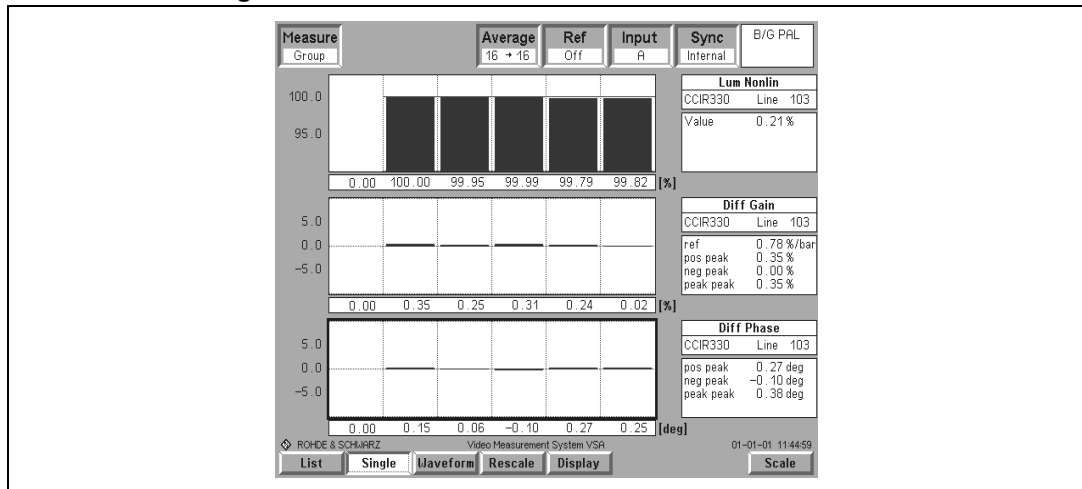

Table 10. Video results

| Parameter | Value $V_{CC} = \pm 2.5 V$ | Value $V_{CC} = \pm 5 V$ | Unit |
|------------------|-------------------------------|-----------------------------|------|
| Lum NL | 0.1 | 0.3 | % |
| Lum NL step 1 | 100 | 100 | |
| Lum NL step 2 | 100 | 99.9 | |
| Lum NL step 3 | 99.9 | 99.8 | |
| Lum NL step 4 | 99.9 | 99.9 | |
| Lum NL step 5 | 99.9 | 99.7 | |
| Diff gain pos | 0 | 0 | |
| Diff gain neg | -0.7 | -0.6 | |
| Diff gain pp | 0.7 | 0.6 | |
| Diff gain step1 | -0.5 | -0.3 | |
| Diff gain step2 | -0.7 | -0.6 | |
| Diff gain step3 | -0.3 | -0.5 | |
| Diff gain step4 | -0.1 | -0.3 | |
| Diff gain step5 | -0.4 | -0.5 | |
| Diff phase pos | 0 | 0.1 | |
| Diff phase neg | -0.2 | -0.4 | |
| Diff phase pp | 0.2 | 0.5 | |
| Diff phase step1 | -0.2 | -0.4 | |
| Diff phase step2 | -0.1 | -0.4 | |
| Diff phase step3 | -0.1 | -0.3 | |
| Diff phase step4 | 0 | 0.1 | |
| Diff phase step5 | -0.2 | -0.1 | |

4.4 Precautions when operating on an asymmetrical supply

The TSH7X can be used with either a dual or a single supply. If a single supply is used, the inputs are biased to the mid-supply voltage ($+V_{CC}/2$). This bias network must be carefully designed, in order to reject any noise present on the supply rail.

As the bias current is $15 \mu A$, you must carefully choose the resistance R1 so as not to introduce an offset mismatch at the amplifier inputs.

Figure 49. Schematic of asymmetrical (single) supply

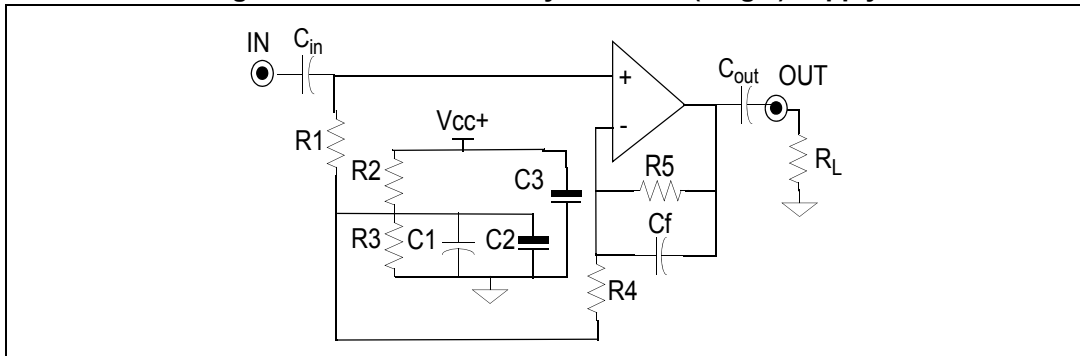

$R1 = 10 \text{ k}\Omega$ is a typical and convenient value. $C1, C2, C3$ are bypass capacitors that filter perturbations on V_{CC} , as well as for the input and output signals. We choose $C1 = 100 \text{ nF}$ and $C2 = C3 = 100 \mu F$.

$R2, R3$ are such that the current through them must be greater than 100 times the bias current. Therefore, we set $R2 = R3 = 4.7 \text{ k}\Omega$

C_{in} , as C_{out} , is chosen to filter the DC signal by the low-pass filters ($R1, C_{in}$ and R_{out}, C_{out}). By taking $R1 = 10 \text{ k}\Omega, R_L = 150 \Omega$ and $C_{in} = 2 \mu F, C_{out} = 220 \mu F$ we provide a cut-off frequency below 10 Hz.

Figure 50. Use of the TSH7x in gain = -1 configuration

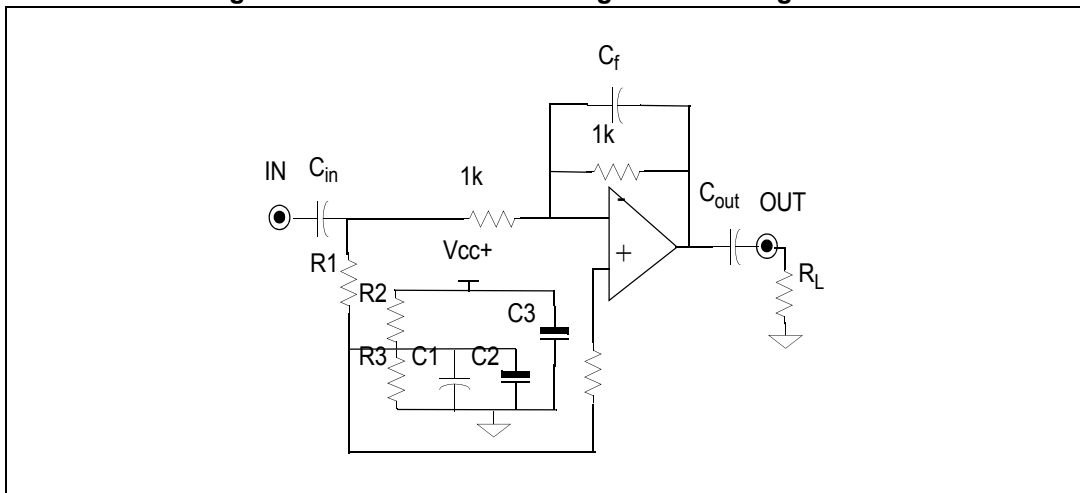

Some precautions must be taken, especially for low-power supply applications.

A feedback capacitance, C_f , should be added for better stability. [Table 11](#) summarizes the impact of the capacitance C_f on the phase margin of the circuit.

Table 11. Impact capacitance C_f

| Parameter | C_f (pF) | $V_{CC} = \pm 1.5\text{ V}$ | $V_{CC} = \pm 2.5\text{ V}$ | $V_{CC} = \pm 5\text{ V}$ | Unit |
|--------------|------------|-----------------------------|-----------------------------|---------------------------|------|
| Phase margin | 0 | 28 | 43 | 56 | deg |
| f-3 dB | | 40 | 39.3 | 38.3 | MHz |
| Phase margin | 5.6 | 30 | 43 | 56 | deg |
| f-3 dB | | 40 | 39.3 | 38.3 | MHz |
| Phase margin | 22 | 37 | 52 | 67 | deg |
| f-3 dB | | 37 | 34 | 32 | MHz |
| Phase margin | 33 | 48 | 65 | 78 | deg |
| f-3 dB | | 33.7 | 30.7 | 27.6 | MHz |

5 Package information

In order to meet environmental requirements, ST offers these devices in different grades of ECOPACK[®] packages, depending on their level of environmental compliance. ECOPACK[®] specifications, grade definitions and product status are available at: www.st.com. ECOPACK[®] is an ST trademark.

5.1 SOT23-5 package information

Figure 51. SOT23-5 package mechanical drawing

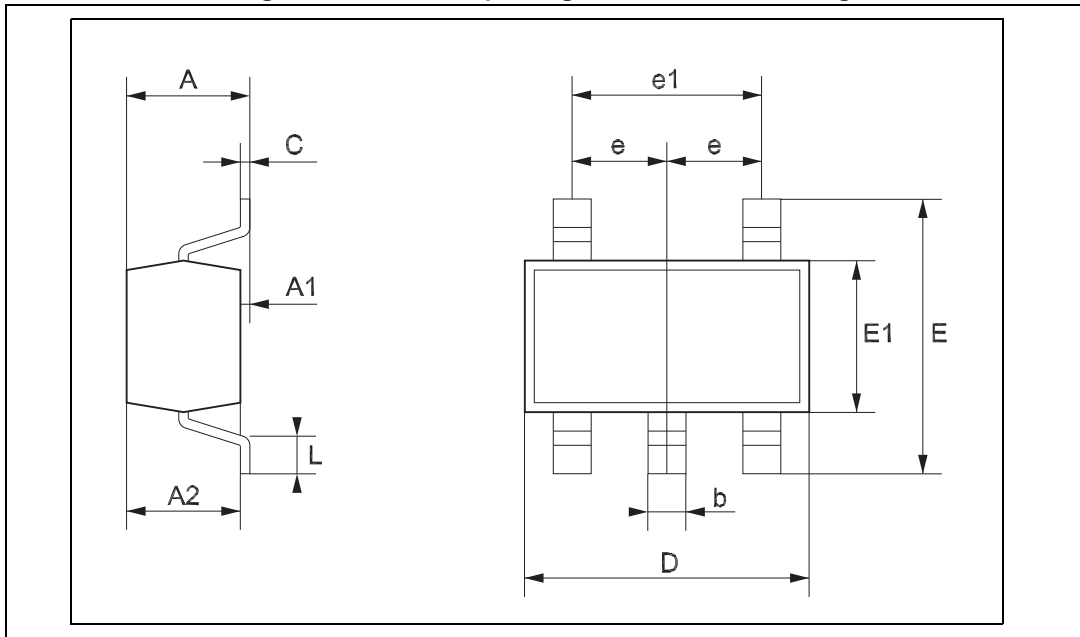

Table 12. SOT23-5 package mechanical data

| Symbol | Dimensions | | | | | |
|--------|-------------|------|------|--------|-------|-------|
| | Millimeters | | | Inches | | |
| | Min | Typ | Max | Min | Typ | Max |
| A | 0.90 | | 1.45 | 0.035 | | 0.057 |
| A1 | 0.00 | | 0.15 | 0.000 | | 0.006 |
| A2 | 0.90 | | 1.30 | 0.035 | | 0.051 |
| b | 0.35 | | 0.50 | 0.014 | | 0.020 |
| C | 0.09 | | 0.20 | 0.004 | | 0.008 |
| D | 2.80 | | 3.00 | 0.110 | | 0.118 |
| E | 2.60 | | 3.00 | 0.102 | | 0.118 |
| E1 | 1.50 | | 1.75 | 0.059 | | 0.069 |
| e | | 0.95 | | | 0.037 | |
| e1 | | 1.9 | | | 0.075 | |
| L | 0.35 | | 0.55 | 0.014 | | 0.022 |

5.2 SO8 package information

Figure 52. SO8 package mechanical drawing

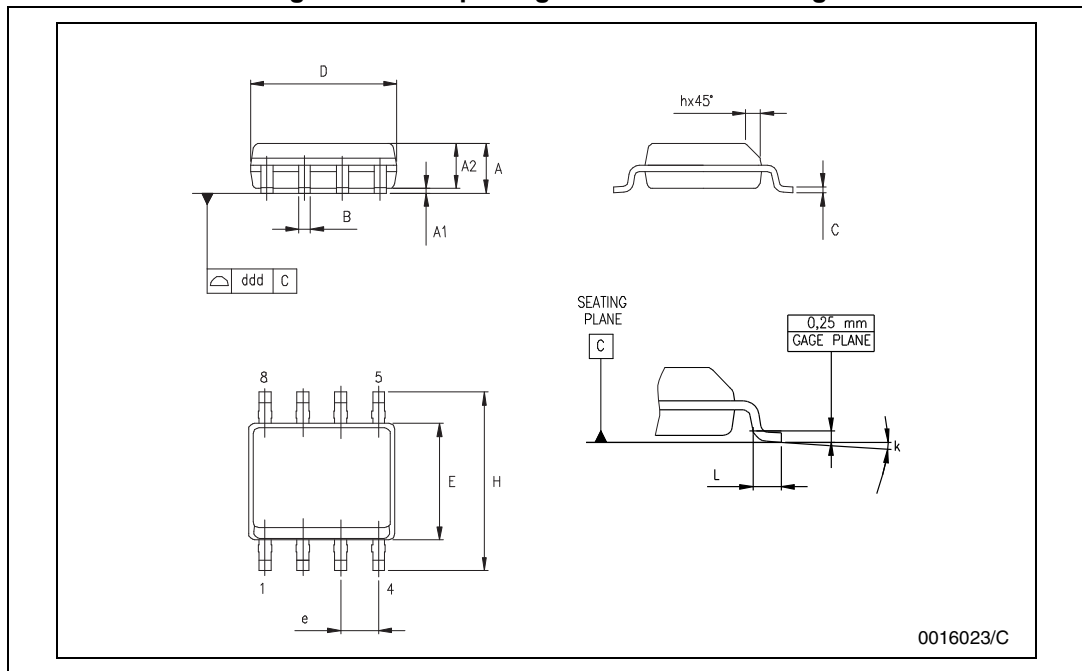

Table 13. SO8 package mechanical data

| Symbol | Dimensions | | | | | |
|--------|-------------|------|------|--------|-------|-------|
| | Millimeters | | | Inches | | |
| | Min | Typ | Max | Min | Typ | Max |
| A | 1.35 | | 1.75 | 0.053 | | 0.069 |
| A1 | 0.10 | | 0.25 | 0.004 | | 0.010 |
| A2 | 1.10 | | 1.65 | 0.043 | | 0.065 |
| B | 0.33 | | 0.51 | 0.013 | | 0.020 |
| C | 0.19 | | 0.25 | 0.007 | | 0.010 |
| D | 4.80 | | 5.00 | 0.189 | | 0.197 |
| E | 3.80 | | 4.00 | 0.150 | | 0.157 |
| e | | 1.27 | | | 0.050 | |
| H | 5.80 | | 6.20 | 0.228 | | 0.244 |
| h | 0.25 | | 0.50 | 0.010 | | 0.020 |
| L | 0.40 | | 1.27 | 0.016 | | 0.050 |
| k | | | 8 ° | | | 8 ° |
| ddd | | | 0.1 | | | 0.004 |

5.3 TSSOP8 package information

Figure 53. TSSOP8 package mechanical drawing

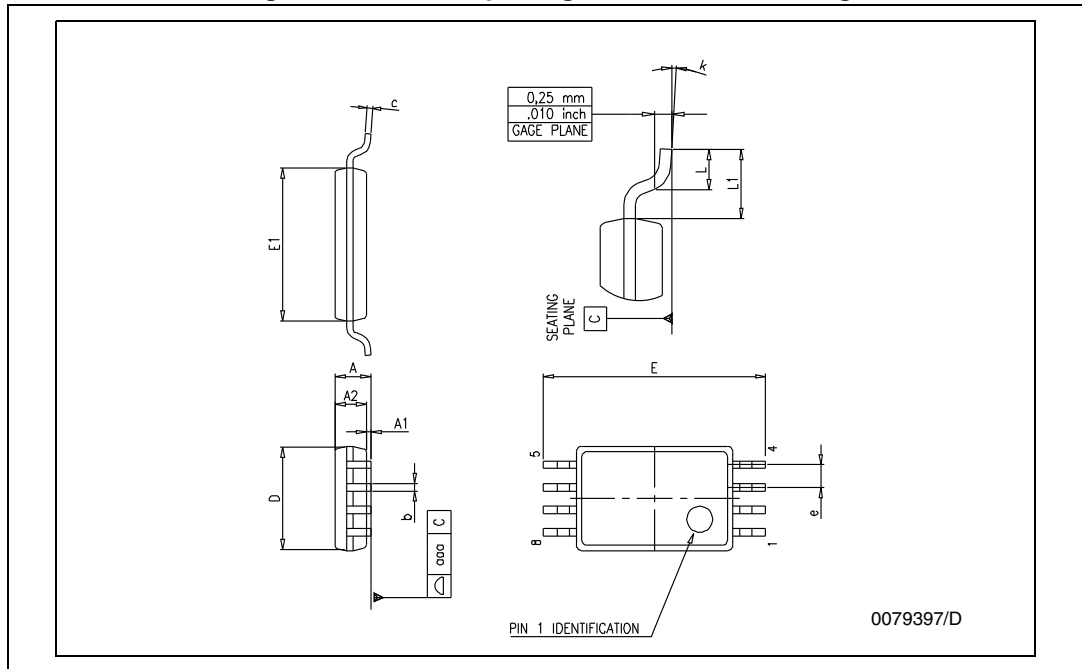

Table 14. TSSOP8 package mechanical data

| Symbol | Dimensions | | | | | |
|--------|-------------|------|------|--------|--------|-------|
| | Millimeters | | | Inches | | |
| | Min | Typ | Max | Min | Typ | Max |
| A | | | 1.2 | | | 0.047 |
| A1 | 0.05 | | 0.15 | 0.002 | | 0.006 |
| A2 | 0.80 | 1.00 | 1.05 | 0.031 | 0.039 | 0.041 |
| b | 0.19 | | 0.30 | 0.007 | | 0.012 |
| c | 0.09 | | 0.20 | 0.004 | | 0.008 |
| D | 2.90 | 3.00 | 3.10 | 0.114 | 0.118 | 0.122 |
| E | 6.20 | 6.40 | 6.60 | 0.244 | 0.252 | 0.260 |
| E1 | 4.30 | 4.40 | 4.50 | 0.169 | 0.173 | 0.177 |
| e | | 0.65 | | | 0.0256 | |
| K | 0° | | 8° | 0° | | 8° |
| L | 0.45 | 0.60 | 0.75 | 0.018 | 0.024 | 0.030 |
| L1 | | 1 | | | 0.039 | |

5.4 SO14 package information

Figure 54. SO14 package mechanical drawing

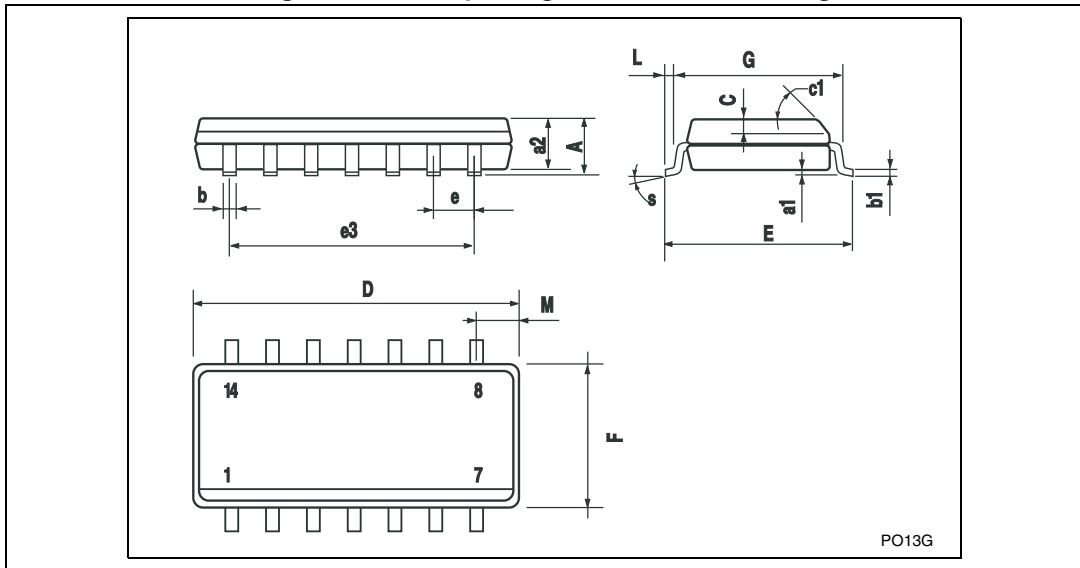

Table 15. SO14 package mechanical data

| Symbol | Dimensions | | | | | |
|--------|-------------|------|------|--------|-------|-------|
| | Millimeters | | | Inches | | |
| | Min | Typ | Max | Min | Typ | Max |
| A | | | 1.75 | | | 0.068 |
| a1 | 0.1 | | 0.2 | 0.003 | | 0.007 |
| a2 | | | 1.65 | | | 0.064 |
| b | 0.35 | | 0.46 | 0.013 | | 0.018 |
| b1 | 0.19 | | 0.25 | 0.007 | | 0.010 |
| C | | 0.5 | | | 0.019 | |
| c1 | | 45 ° | | | 45 ° | |
| D | 8.55 | | 8.75 | 0.336 | | 0.344 |
| E | 5.8 | | 6.2 | 0.228 | | 0.244 |
| e | | 1.27 | | | 0.050 | |
| e3 | | 7.62 | | | 0.300 | |
| F | 3.8 | | 4.0 | 0.149 | | 0.157 |
| G | 4.6 | | 5.3 | 0.181 | | 0.208 |
| L | 0.5 | | 1.27 | 0.019 | | 0.050 |
| M | | | 0.68 | | | 0.026 |
| S | | | 8 ° | | | 8 ° |

5.5 TSSOP14 package information

Figure 55. TSSOP14 package mechanical drawing

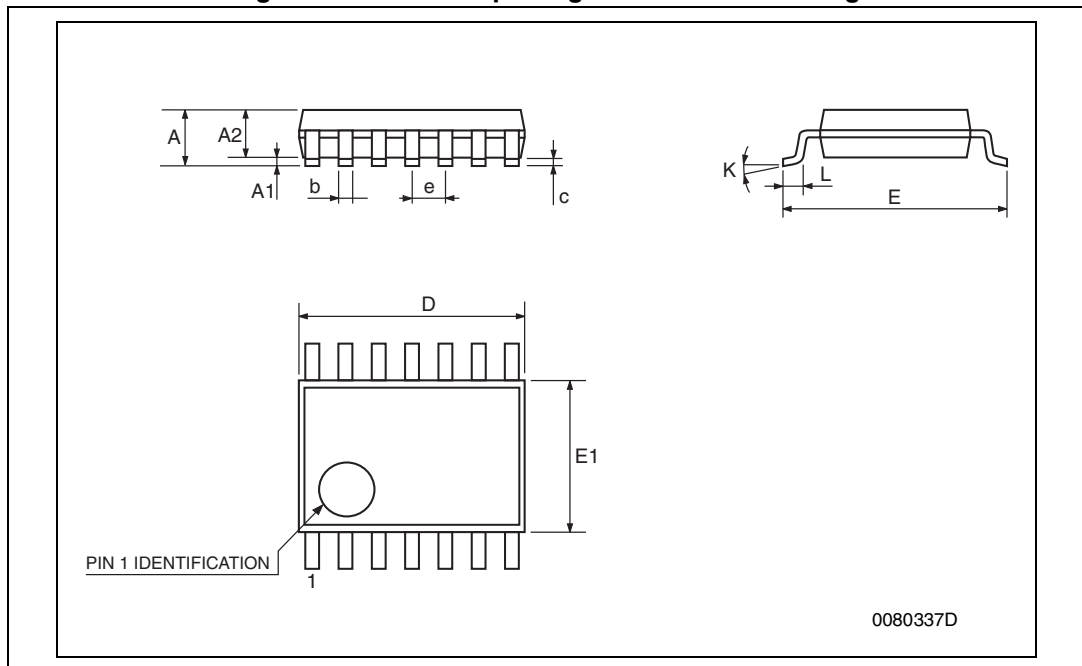

Table 16. TSSOP14 package mechanical data

| Symbol | Dimensions | | | | | |
|--------|-------------|------|------|--------|--------|--------|
| | Millimeters | | | Inches | | |
| | Min | Typ | Max | Min | Typ | Max |
| A | | | 1.2 | | | 0.047 |
| A1 | 0.05 | | 0.15 | 0.002 | 0.004 | 0.006 |
| A2 | 0.8 | 1 | 1.05 | 0.031 | 0.039 | 0.041 |
| b | 0.19 | | 0.30 | 0.007 | | 0.012 |
| c | 0.09 | | 0.20 | 0.004 | | 0.0089 |
| D | 4.9 | 5 | 5.1 | 0.193 | 0.197 | 0.201 |
| E | 6.2 | 6.4 | 6.6 | 0.244 | 0.252 | 0.260 |
| E1 | 4.3 | 4.4 | 4.48 | 0.169 | 0.173 | 0.176 |
| e | | 0.65 | | | 0.0256 | |
| K | 0 ° | | 8 ° | 0 ° | | 8 ° |
| L | 0.45 | 0.60 | 0.75 | 0.018 | 0.024 | 0.030 |

5.6 SO16 package information

Figure 56. SO16 package mechanical drawing

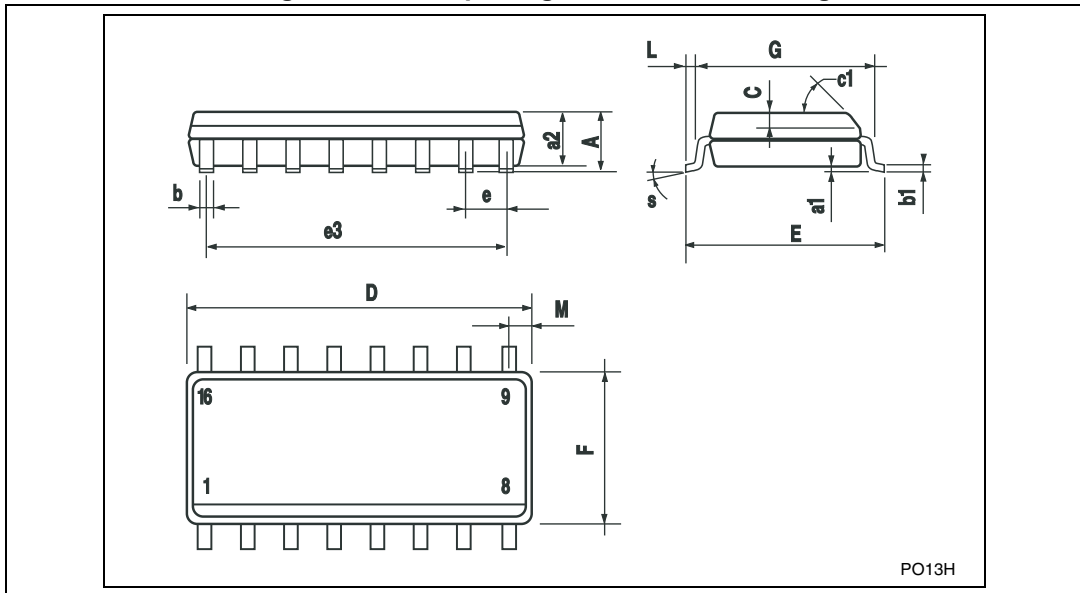

Table 17. SO16 package mechanical data

| Symbol | Dimensions | | | | | |
|--------|-------------|------|------|--------|-------|-------|
| | Millimeters | | | Inches | | |
| | Min | Typ | Max | Min | Typ | Max |
| A | | | 1.75 | | | 0.068 |
| a1 | 0.1 | | 0.2 | 0.004 | | 0.008 |
| a2 | | | 1.65 | | | 0.064 |
| b | 0.35 | | 0.46 | 0.013 | | 0.018 |
| b1 | 0.19 | | 0.25 | 0.007 | | 0.010 |
| C | | 0.5 | | | 0.019 | |
| c1 | | 45 ° | | | 45 ° | |
| D | 9.8 | | | 0.385 | | 0.393 |
| E | 5.8 | | 10 | 0.228 | | 0.244 |
| e | | 1.27 | 6.2 | | 0.050 | |
| e3 | | 8.89 | | | 0.350 | |
| F | 3.8 | | 4.0 | 0.149 | | 0.157 |
| G | 4.6 | | 5.3 | 0.181 | | 0.208 |
| L | 0.5 | | 1.27 | 0.019 | | 0.050 |
| M | | | 0.62 | | | 0.024 |
| S | | | 8 ° | | | 8 ° |

5.7 TSSOP16 package information

Figure 57. TSSOP16 package mechanical drawing

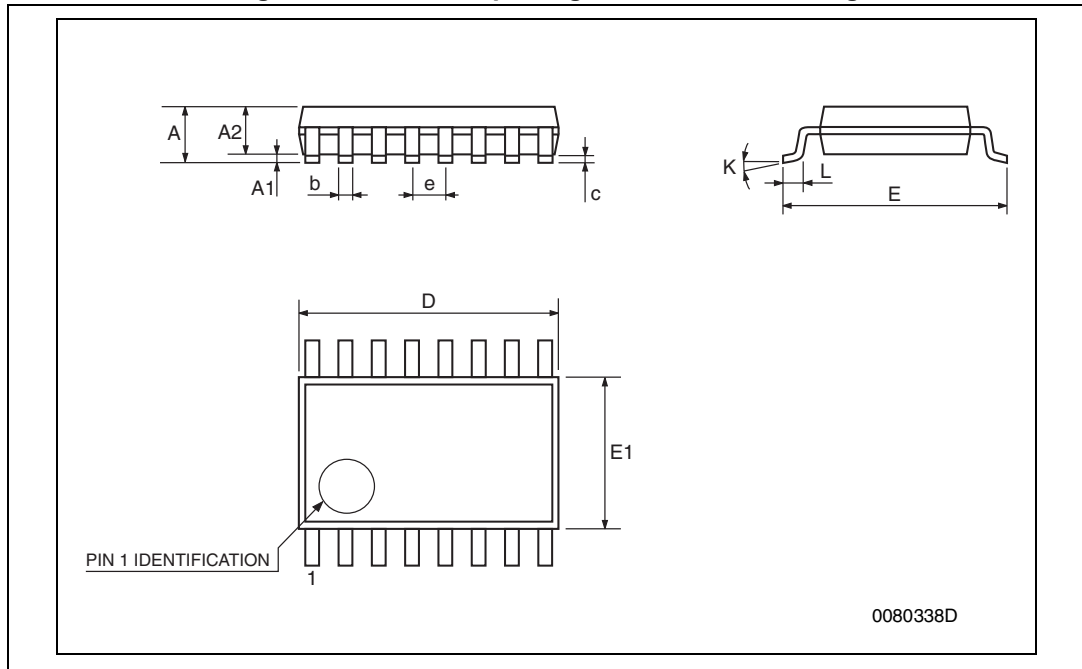

Table 18. TSSOP16 package mechanical data

| Symbol | Dimensions | | | | | |
|--------|-------------|------|------|--------|--------|--------|
| | Millimeters | | | Inches | | |
| | Min | Typ | Max | Min | Typ | Max |
| A | | | 1.2 | | | 0.047 |
| A1 | 0.05 | | 0.15 | 0.002 | | 0.006 |
| A2 | 0.8 | 1 | 1.05 | 0.031 | 0.039 | 0.041 |
| b | 0.19 | | 0.30 | 0.007 | | 0.012 |
| c | 0.09 | | 0.20 | 0.004 | | 0.0079 |
| D | 4.9 | 5 | 5.1 | 0.193 | 0.197 | 0.201 |
| E | 6.2 | 6.4 | 6.6 | 0.244 | 0.252 | 0.260 |
| E1 | 4.3 | 4.4 | 4.48 | 0.169 | 0.173 | 0.176 |
| e | | 0.65 | | | 0.0256 | |
| K | 0° | | 8° | 0° | | 8° |
| L | 0.45 | 0.60 | 0.75 | 0.018 | 0.024 | 0.030 |

6 Order information

Table 19. Order codes

| Part number | Temperature range | Package | Packing | Marking |
|-------------|-------------------|---------|-----------------------|---------|
| TSH70CLT | 0 °C to 70 °C | SOT23-5 | Tape and reel | K301 |
| TSH70CD/CDT | | SO8 | Tube or tape and reel | 70C |
| TSH71CD/CDT | | | | 71C |
| TSH71CPT | | TSSOP8 | Tape and reel | 72C |
| TSH72CD/CDT | | SO8 | Tube or tape and reel | |
| TSH72CPT | | TSSOP8 | Tape and reel | 73C |
| TSH73CD/CDT | | SO14 | Tube or tape and reel | |
| TSH73CPT | | TSSOP14 | Tape and reel | 74C |
| TSH74CD/CDT | | SO14 | Tube or tape and reel | |
| TSH74CPT | | TSSOP14 | Tape and reel | 75C |
| TSH75CD/CDT | | SO16 | Tube or tape and reel | |
| TSH75CPT | | TSSOP16 | Tape and reel | |

7 Revision history

Table 20. Document revision history

| Date | Revision | Changes |
|-------------|----------|--|
| Nov. 2000 | 1 | First Release. |
| Aug. 2002 | 2 | Limit min. of I_{sink} from 24mA to 20mA (only on 3V power supply). Reason: yield improvement. |
| May 2006 | 3 | Improvement of VOL max. at 3V and 5V power supply on 150-ohm load connected to GND (pages 6 and 8). Reason: TSH7x can drive video signals from DACs to lines in single supply (3V or 5V) without any DC level change of the video signals. Grammatical and typographical changes throughout. Package mechanical data updated. |
| 05-Dec-2013 | 4 | Updated slew rate in Features Table 12: SOT23-5 package mechanical data : added information for inches. |

Please Read Carefully:

Information in this document is provided solely in connection with ST products. STMicroelectronics NV and its subsidiaries ("ST") reserve the right to make changes, corrections, modifications or improvements, to this document, and the products and services described herein at any time, without notice.

All ST products are sold pursuant to ST's terms and conditions of sale.

Purchasers are solely responsible for the choice, selection and use of the ST products and services described herein, and ST assumes no liability whatsoever relating to the choice, selection or use of the ST products and services described herein.

No license, express or implied, by estoppel or otherwise, to any intellectual property rights is granted under this document. If any part of this document refers to any third party products or services it shall not be deemed a license grant by ST for the use of such third party products or services, or any intellectual property contained therein or considered as a warranty covering the use in any manner whatsoever of such third party products or services or any intellectual property contained therein.

UNLESS OTHERWISE SET FORTH IN ST'S TERMS AND CONDITIONS OF SALE ST DISCLAIMS ANY EXPRESS OR IMPLIED WARRANTY WITH RESPECT TO THE USE AND/OR SALE OF ST PRODUCTS INCLUDING WITHOUT LIMITATION IMPLIED WARRANTIES OF MERCHANTABILITY, FITNESS FOR A PARTICULAR PURPOSE (AND THEIR EQUIVALENTS UNDER THE LAWS OF ANY JURISDICTION), OR INFRINGEMENT OF ANY PATENT, COPYRIGHT OR OTHER INTELLECTUAL PROPERTY RIGHT.

ST PRODUCTS ARE NOT DESIGNED OR AUTHORIZED FOR USE IN: (A) SAFETY CRITICAL APPLICATIONS SUCH AS LIFE SUPPORTING, ACTIVE IMPLANTED DEVICES OR SYSTEMS WITH PRODUCT FUNCTIONAL SAFETY REQUIREMENTS; (B) AERONAUTIC APPLICATIONS; (C) AUTOMOTIVE APPLICATIONS OR ENVIRONMENTS, AND/OR (D) AEROSPACE APPLICATIONS OR ENVIRONMENTS. WHERE ST PRODUCTS ARE NOT DESIGNED FOR SUCH USE, THE PURCHASER SHALL USE PRODUCTS AT PURCHASER'S SOLE RISK, EVEN IF ST HAS BEEN INFORMED IN WRITING OF SUCH USAGE, UNLESS A PRODUCT IS EXPRESSLY DESIGNATED BY ST AS BEING INTENDED FOR "AUTOMOTIVE, AUTOMOTIVE SAFETY OR MEDICAL" INDUSTRY DOMAINS ACCORDING TO ST PRODUCT DESIGN SPECIFICATIONS. PRODUCTS FORMALLY ESCC, QML OR JAN QUALIFIED ARE DEEMED SUITABLE FOR USE IN AEROSPACE BY THE CORRESPONDING GOVERNMENTAL AGENCY.

Resale of ST products with provisions different from the statements and/or technical features set forth in this document shall immediately void any warranty granted by ST for the ST product or service described herein and shall not create or extend in any manner whatsoever, any liability of ST.

ST and the ST logo are trademarks or registered trademarks of ST in various countries.

Information in this document supersedes and replaces all information previously supplied.

The ST logo is a registered trademark of STMicroelectronics. All other names are the property of their respective owners.

© 2013 STMicroelectronics - All rights reserved

STMicroelectronics group of companies

Australia - Belgium - Brazil - Canada - China - Czech Republic - Finland - France - Germany - Hong Kong - India - Israel - Italy - Japan - Malaysia - Malta - Morocco - Philippines - Singapore - Spain - Sweden - Switzerland - United Kingdom - United States of America

www.st.com