

Ultra low drop BICMOS voltage regulator

Datasheet - production data

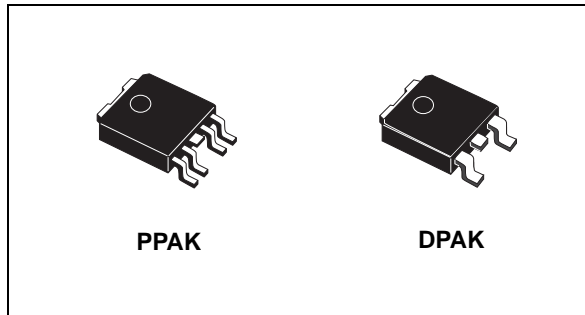

Features

- 3 A guaranteed output current
- Ultra low dropout voltage (200 mV typ. @ 3 A load, 40 mV typ. @ 600 mA load)
- Very low quiescent current (1.2 mA typ. @ 3 A load, 1 μ A max @ 25 °C in off mode)
- Logic-controlled electronic shutdown
- Current and thermal internal limit
- $\pm 1.5\%$ output voltage tolerance @ 25 °C
- Fixed and ADJ output voltages: 1.22 V, 1.8 V, 2.5 V, 3.3 V, ADJ
- Temperature range: -40 to 125 °C
- Fast dynamic response to line and load changes
- Stable with ceramic capacitor
- Available in PPAK and DPAK

Application

- Microprocessor power supply
- DSPs power supply
- Post regulators for switching power supplies
- High efficiency linear regulator

Description

The LD39300 is a fast ultra low drop linear regulator which operates from 2.5 V to 6 V input supply.

A wide range of output options are available. The low drop voltage, low noise, and ultra low quiescent current make it suitable for low voltage microprocessor and memory applications. The device is developed on a BiCMOS process which allows low quiescent current operation independently of output load current.

Table 1. Device summary

Part numbers		Output voltage
DPAK	PPAK	
LD39300DT12-R		1.22V
LD39300DT18-R	LD39300PT18-R ⁽¹⁾	1.8V
LD39300DT25-R	LD39300PT25-R ⁽¹⁾	2.5V
LD39300DT33-R	LD39300PT33-R ⁽¹⁾	3.3V
	LD39300PT-R	ADJ from 1.22 to 5.0V

1. Available on request

Contents

1	Diagram	3
2	Pin configuration	4
3	Typical application circuits	5
4	Maximum ratings	7
5	Electrical characteristics	8
6	Typical performance characteristics	10
7	Application notes	13
	7.1 External capacitors	13
	7.2 Input capacitor	13
	7.3 Output capacitor	13
	7.4 Thermal note	13
	7.5 Inhibit input operation	13
8	Package mechanical data	14
9	Packaging mechanical data	20
10	Revision history	22

1 Diagram

Figure 1. Block diagram

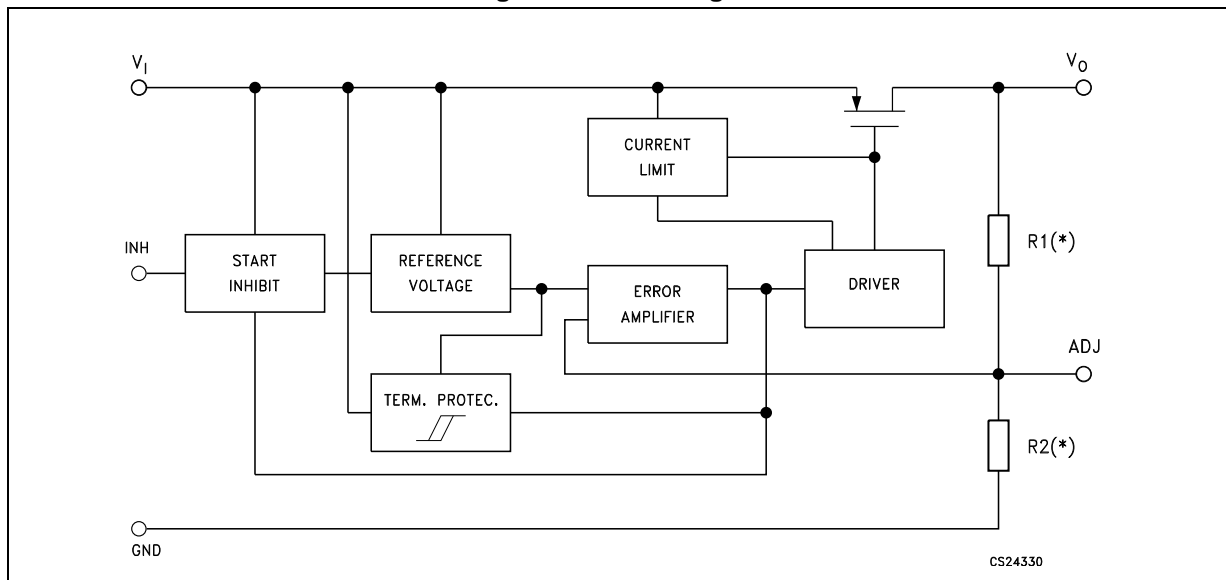

(*) Not present on ADJ versions

2 Pin configuration

Figure 2. Pin connections (top view for DPAK and PPAK)

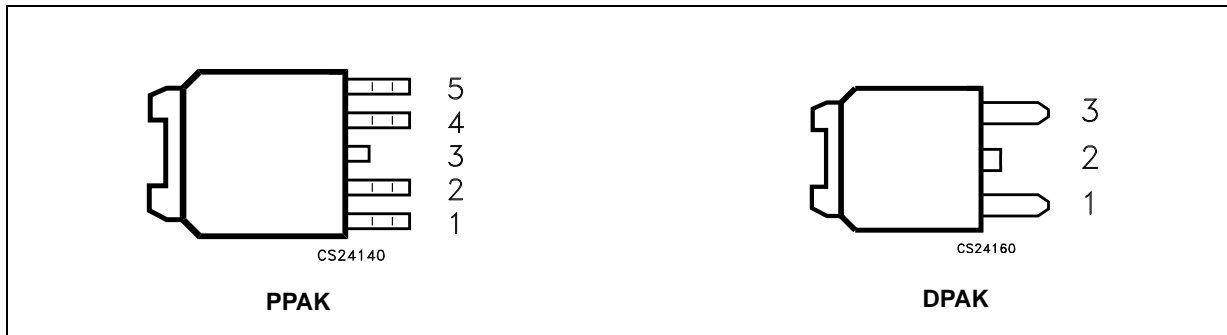

Table 2. Pin description

Pin N°		Symbol	Note
PPAK	DPAK		
5		V _{SENSE} /N.C.	For fixed versions: Not Connected on PPAK
		ADJ	For adjustable version: Error Amplifier Input pin for V _O from 1.22 to 5.0V
2	1	V _I	LDO Input Voltage; V _I from 2.5V to 6V, C _I =1μF must be located at a distance of not more than 0.5" from input pin.
4	3	V _O	LDO Output Voltage pins, with minimum C _O =4.7μF needed for stability (also refer to C _O vs. ESR stability chart)
1		V _{INH}	Inhibit Input Voltage: ON MODE when V _{INH} ≥ 2V, OFF MODE when V _{INH} ≤ 0.3V (Do not leave floating, not internally pulled down/up)
3	2	GND	Common ground
TAB		GND	Tab is connected to GND

3 Typical application circuits

C_1 and C_O Capacitors must be placed as close as possible to the IC pins.

Figure 3. LD39300 fixed version with inhibit

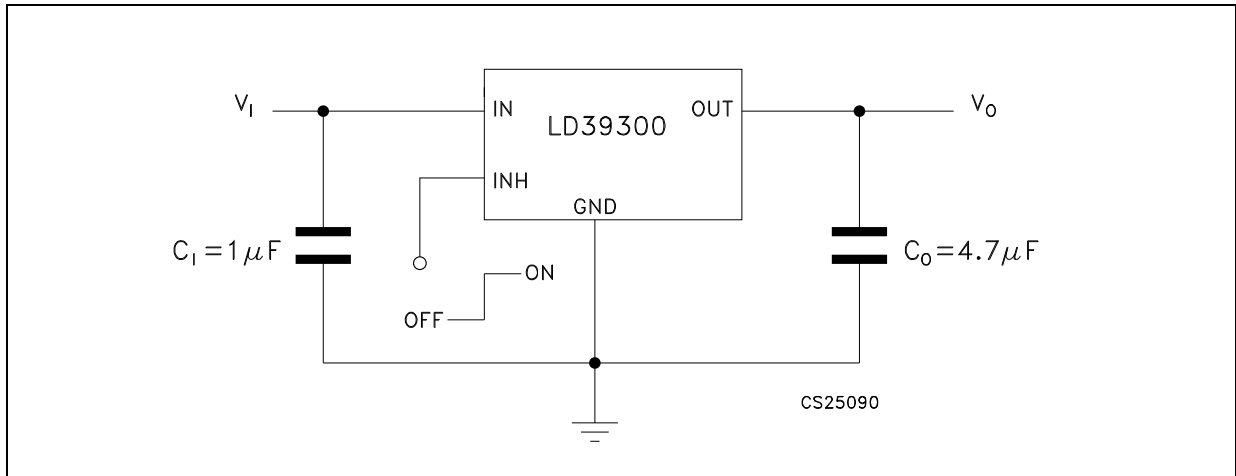

- 1 *Inhibit Pin is not internally pulled down/up then it must not be left floating. Disable the device when connected to GND or to a positive voltage less than 0.3 V*

Figure 4. LD39300 adjustable version

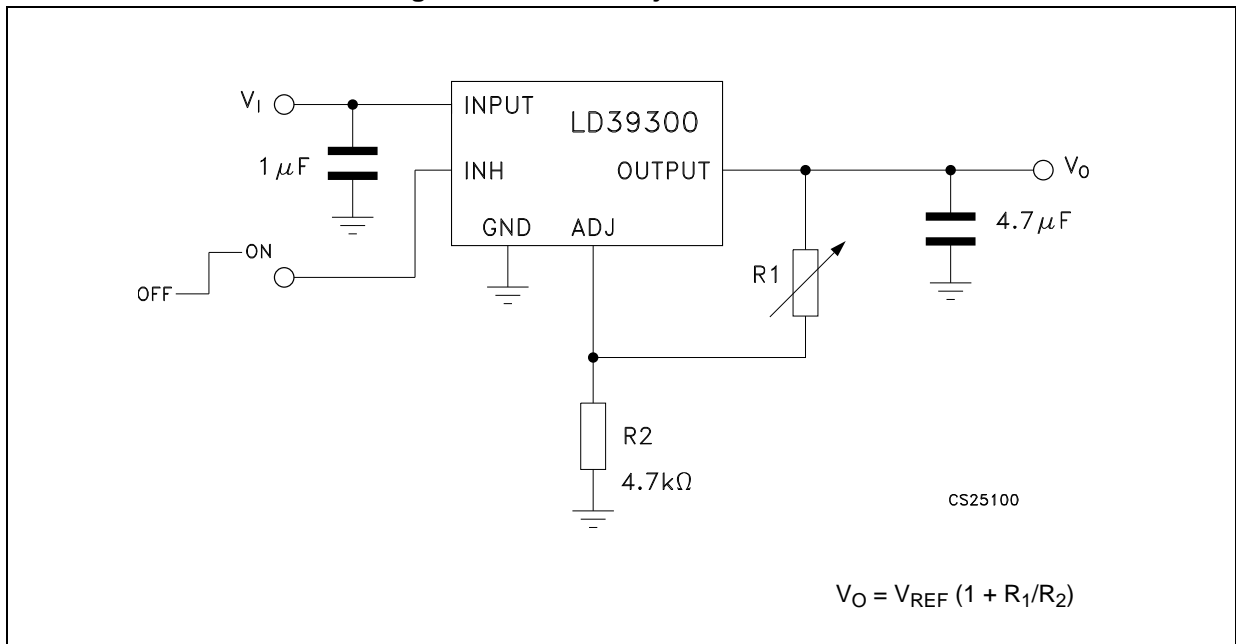

- 2 *Set R2 as close as possible to 4.7 KΩ*

Figure 5. LD39300 DPAK

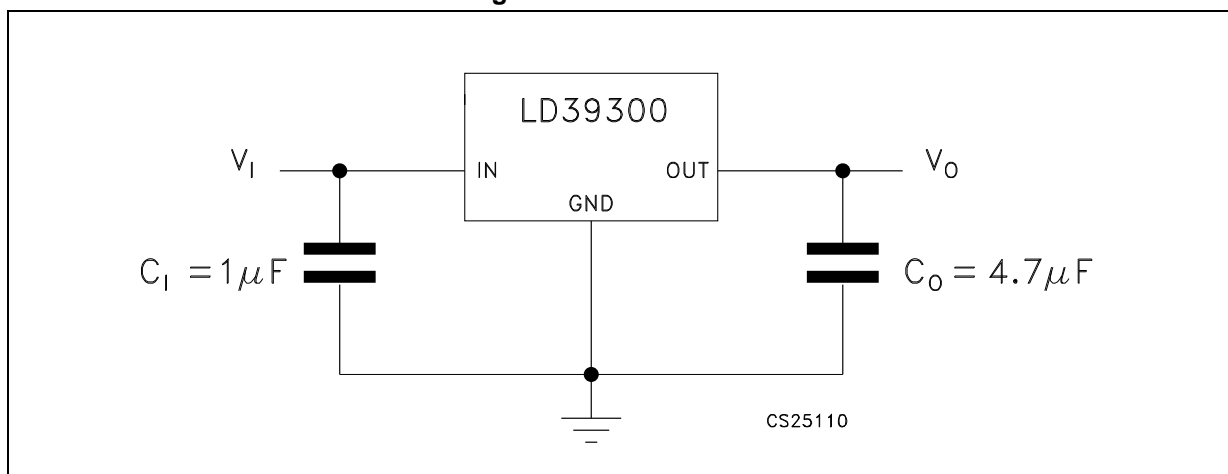
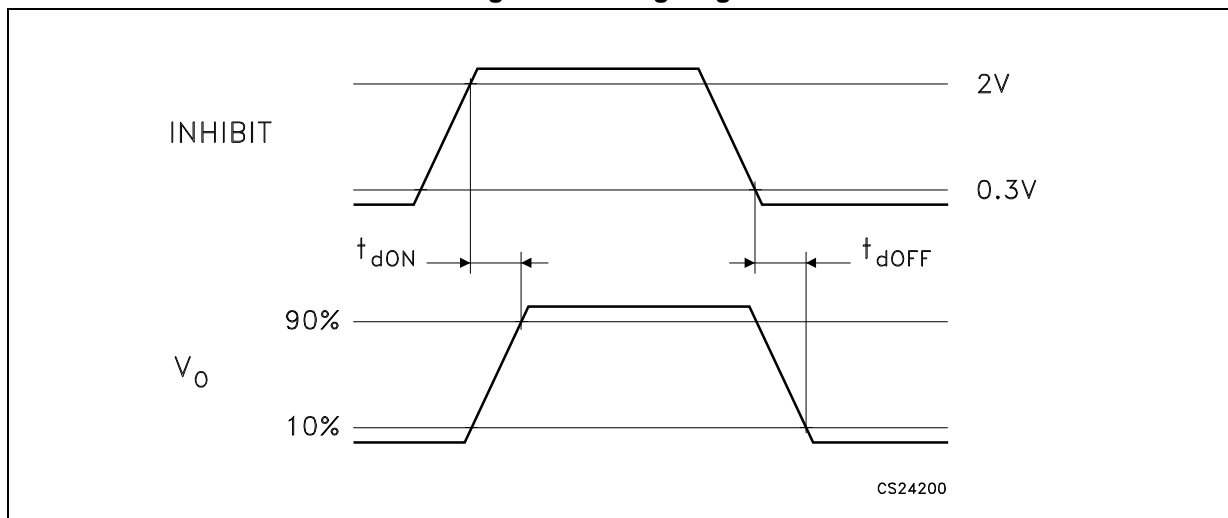

Figure 6. Timing diagram



4 Maximum ratings

Table 3. Absolute maximum ratings

Symbol	Parameter	Value	Unit
V_I	DC input voltage	-0.3 to 6.5	V
V_{INH}	INHIBIT input voltage	-0.3 to $V_I + 0.3$ (6.5V max)	V
V_O	DC output voltage	-0.3 to $V_I + 0.3$ (6.5V max)	V
V_{ADJ}	ADJ pin voltage	-0.3 to $V_I + 0.3$ (6.5V max)	V
I_O	Output current	Internally limited	mA
P_D	Power dissipation	Internally limited	mW
T_{STG}	Storage temperature range	-50 to 150	°C
T_{OP}	Operating junction temperature range	-40 to 125	°C

Note: Absolute Maximum Ratings are those values beyond which damage to the device may occur. Functional operation under these conditions is not implied. All values are referred to GND.

Table 4. Thermal data

Symbol	Parameter	PPAK	DPAK	Unit
R_{thJA}	Thermal resistance junction-ambient	100	100	°C/W
R_{thJC}	Thermal resistance junction-case	8	8	°C/W

5 Electrical characteristics

$T_J = 25^\circ\text{C}$, $V_I = V_O + 1\text{ V}$, $C_I = 1\ \mu\text{F}$, $C_O = 4.7\ \mu\text{F}$, $I_{\text{LOAD}} = 10\ \text{mA}$, $V_{\text{INH}} = 2\ \text{V}$, unless otherwise specified.

Table 5. Electrical characteristics

Symbol	Parameter	Parameter	Min.	Typ.	Max.	Unit
V_I	Operating input voltage		2.5		6	V
V_O	Output voltage tolerance	$V_I = V_O + 1\text{V}$, $I_{\text{LOAD}} = 10\text{mA to } 3\text{A}$	-1.5		1.5	% of $V_{O(\text{NOM})}$
		$V_I = V_O + 1\text{V to } 6\text{V}$, $I_{\text{LOAD}} = 10\text{mA to } 3\text{A}$ $T_J = -40\text{ to } 125^\circ\text{C}$	-3		3	
V_{REF}	Reference voltage			1.22		V
ΔV_O	Output voltage LINE regulation	$V_I = V_O + 1\text{V to } 6\text{V}$		0.04		%
		$V_I = V_O + 1\text{V to } 6\text{V}$, $T_J = -40\text{ to } 125^\circ\text{C}$		0.1	0.2	%
$\Delta V_O / \Delta I_{\text{LOAD}}$	Output voltage LOAD regulation	$I_{\text{LOAD}} = 10\text{mA to } 3\text{A}$		0.06		% / A
		$I_{\text{LOAD}} = 10\text{mA to } 3\text{A}$, $T_J = -40\text{ to } 125^\circ\text{C}$		0.2	0.4	
V_{DROP}	Dropout voltage ($V_I - V_O$)	$I_{\text{LOAD}} = 600\text{mA}$, $T_J = -40\text{ to } 125^\circ\text{C}$		40	80	mV
		$I_{\text{LOAD}} = 3\text{A}$, $T_J = -40\text{ to } 125^\circ\text{C}$		200	400	
I_Q	Quiescent current: ON MODE	$I_{\text{LOAD}} = 10\text{mA to } 3\text{A}$, $V_{\text{INH}} = 2\text{V}$ $T_J = -40\text{ to } 125^\circ\text{C}$		1.2	2.5	mA
	Quiescent current: OFF MODE	$V_{\text{INH}} = 0.3\text{V}$			1	μA
		$V_{\text{INH}} = 0.3\text{V}$, $T_J = -40\text{ to } 125^\circ\text{C}$			5	
Short Circuit Protection						
I_{SC}	Short circuit protection	$R_L = 0$		6		A
Inhibit Input						
V_{INH}	Inhibit threshold LOW	$V_I = 2.5\text{ to } 6\text{V OFF}$ $T_J = -40\text{ to } 125^\circ\text{C}$			0.3	V
	Inhibit threshold HIGH		2			
$T_{\text{D-OFF}}$	Current limit	$I_{\text{LOAD}} = 3\text{A}$, $V_O = 3.3\text{V}$		20		μs
$T_{\text{D-ON}}$	Current limit	$I_{\text{LOAD}} = 3\text{A}$, $V_O = 3.3\text{V}$		20		
I_{INH}	Inhibit input current ⁽¹⁾	$V_I = 6\text{V}$, $V_{\text{INH}} = 0\text{ to } 6\text{V}$		± 0.1	± 1	μA

Table 5. Electrical characteristics (continued)

Symbol	Parameter	Parameter	Min.	Typ.	Max.	Unit
AC Parameters						
SVR	Supply voltage rejection	$V_I = 4.5 \pm 1V$, $V_O = 3.3V$, $I_{LOAD} = 10mA$,	$f = 120Hz$		65	dB
			$f = 1kHz$		55	
e_N	Output noise voltage	$B_W = 10Hz$ to $100kHz$, $C_O = 4.7\mu F$, $V_O = 2.5V$		100		μV_{RMS}
T_{SHDN}	Thermal shutdown OFF			170		°C
	Hysteresis			10		

1. Guaranteed by design

6 Typical performance characteristics

($T_J = 25^\circ\text{C}$, $V_I = V_O + 1\text{V}$, $C_I = 1\mu\text{F}$, $C_O = 4.7\mu\text{F}$, $I_{\text{LOAD}} = 10\text{mA}$, $V_{\text{INH}} = V_I$, unless otherwise specified)

Figure 7. Output voltage vs temperature

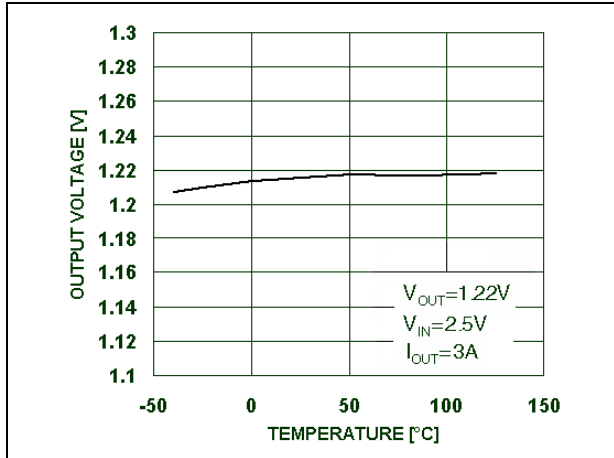

Figure 8. Dropout voltage vs temperature

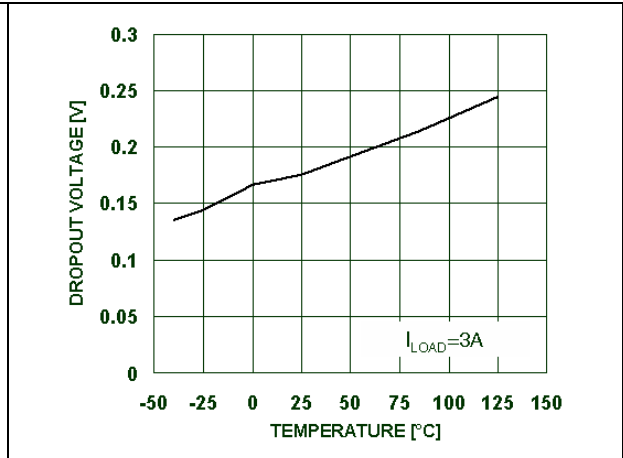

Figure 9. Dropout voltage vs output current

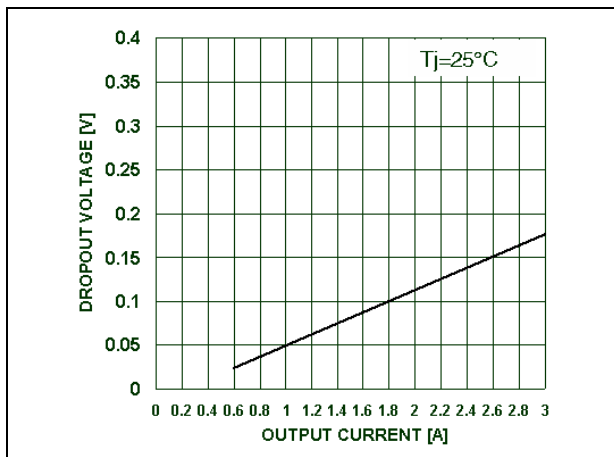

Figure 10. Quiescent current vs temperature ($I_{\text{out}} = 10\text{mA}$)

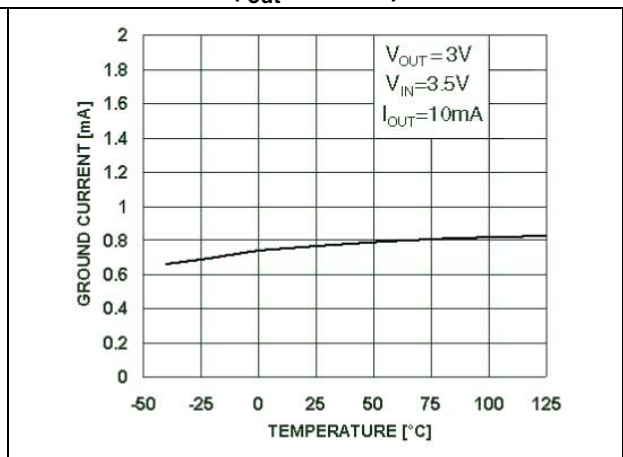

Figure 11. Quiescent current vs temperature
($I_{out} = 3\text{ A}$)

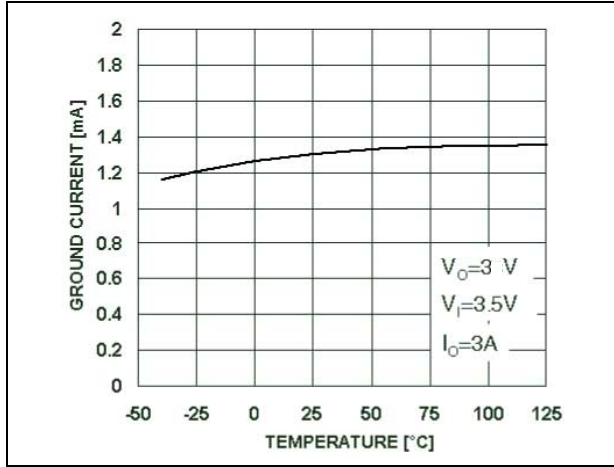

Figure 12. Short circuit current vs temperature

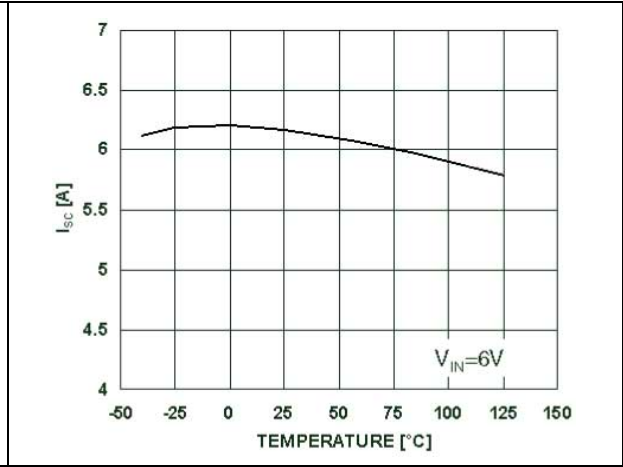

Figure 13. Output voltage vs input voltage

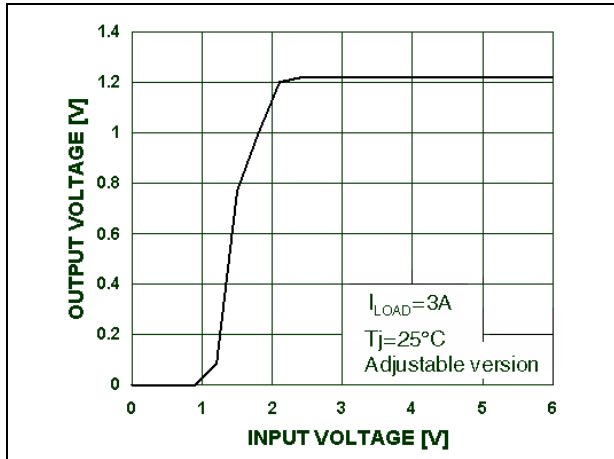

Figure 14. Stability region vs C_O & ESR

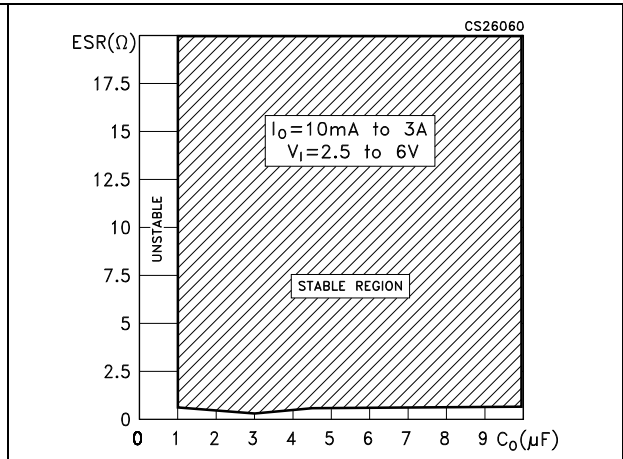

Figure 15. Stability region vs C_O & ESR (low ESR zoom area)

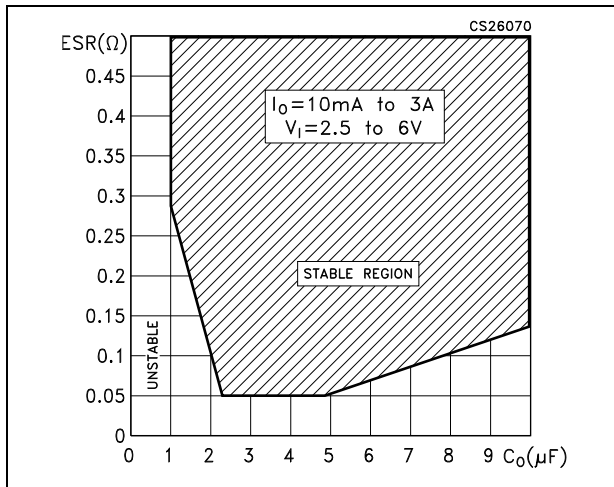

Figure 16. Load transient (fall time)

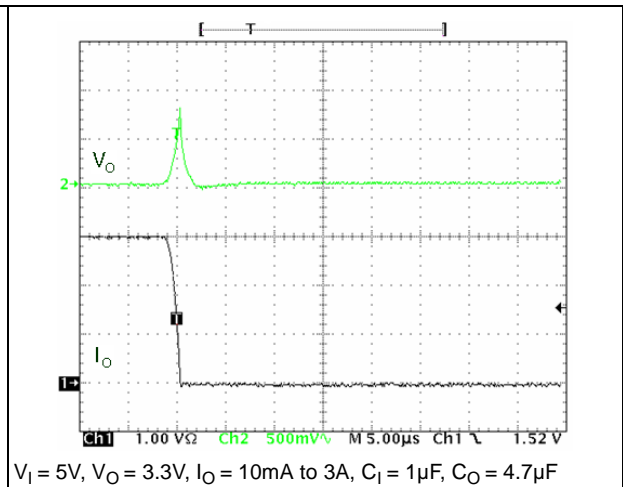

Figure 17. Load transient (rise time)

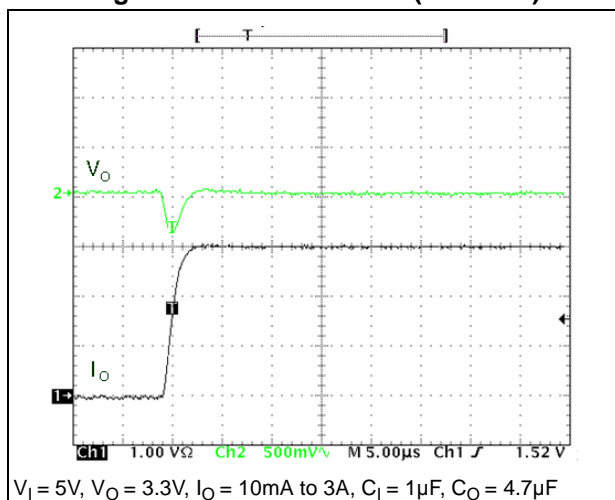
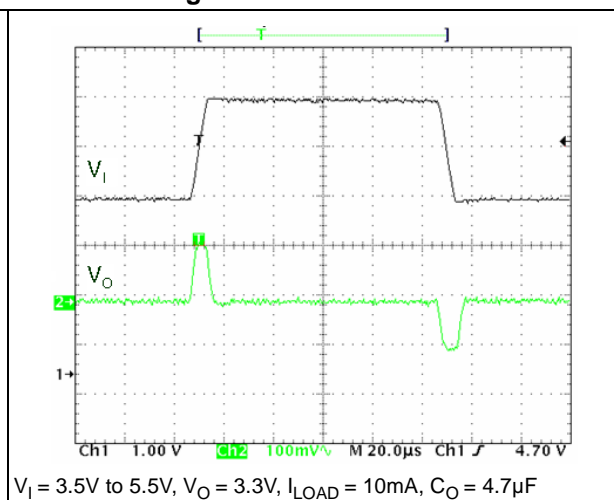

Figure 18. Line transient



7 Application notes

7.1 External capacitors

The LD39300 requires external capacitors for regulator stability. These capacitors must be selected to meet the requirements of minimum capacitance and equivalent series resistance (see [Figure 14](#) and [Figure 15](#)). The input/output capacitors must be located less than 1cm from the relative pins and connected directly to the input/output ground pins using traces which have no other currents flowing through them. Any good quality of Ceramic or Electrolytic capacitors can be used.

7.2 Input capacitor

An input capacitor whose minimum value is 1 μF is required with the LD39300 (amount of capacitance can be increased without limit). This capacitor must be located a distance of not more than 1 cm from the input pin of the device and returned to a clean analog ground. Any good quality ceramic, tantalum or film capacitors can be used for this capacitor.

7.3 Output capacitor

It is possible to use Ceramic or Tantalum capacitors but the output capacitor must meet the requirement for minimum amount of capacitance and E.S.R. (equivalent series resistance) value. A minimum capacitance of 4.7 μF is a good choice to guarantee the stability of the regulator. Anyway, other C_O values can be used according to the ([Figure 14](#) and [Figure 15](#)) showing the allowable ESR range as a function of the output capacitance. This curve represents the stability region over the full temperature and I_O range.

7.4 Thermal note

The output capacitor must maintain its ESR in the stable region over the full operating temperature range to assure stability. Also, capacitors tolerance and variation with temperature must be kept in consideration in order to assure the minimum amount of capacitance at all times.

7.5 Inhibit input operation

The inhibit pin can be used to turn OFF the regulator when pulled down, so drastically reducing the current consumption down to less than 1 μA . When the inhibit feature is not used, this pin must be tied to V_I to keep the regulator output ON at all times. To assure proper operation, the signal source used to drive the inhibit pin must be able to swing above and below the specified thresholds listed in the electrical characteristics section (V_{IH} V_{IL}). The inhibit pin must not be left floating because it is not internally pulled down/up.

8 Package mechanical data

In order to meet environmental requirements, ST offers these devices in different grades of ECOPACK® packages, depending on their level of environmental compliance. ECOPACK® specifications, grade definitions and product status are available at: www.st.com. ECOPACK® is an ST trademark.

Figure 19. DPAK drawing

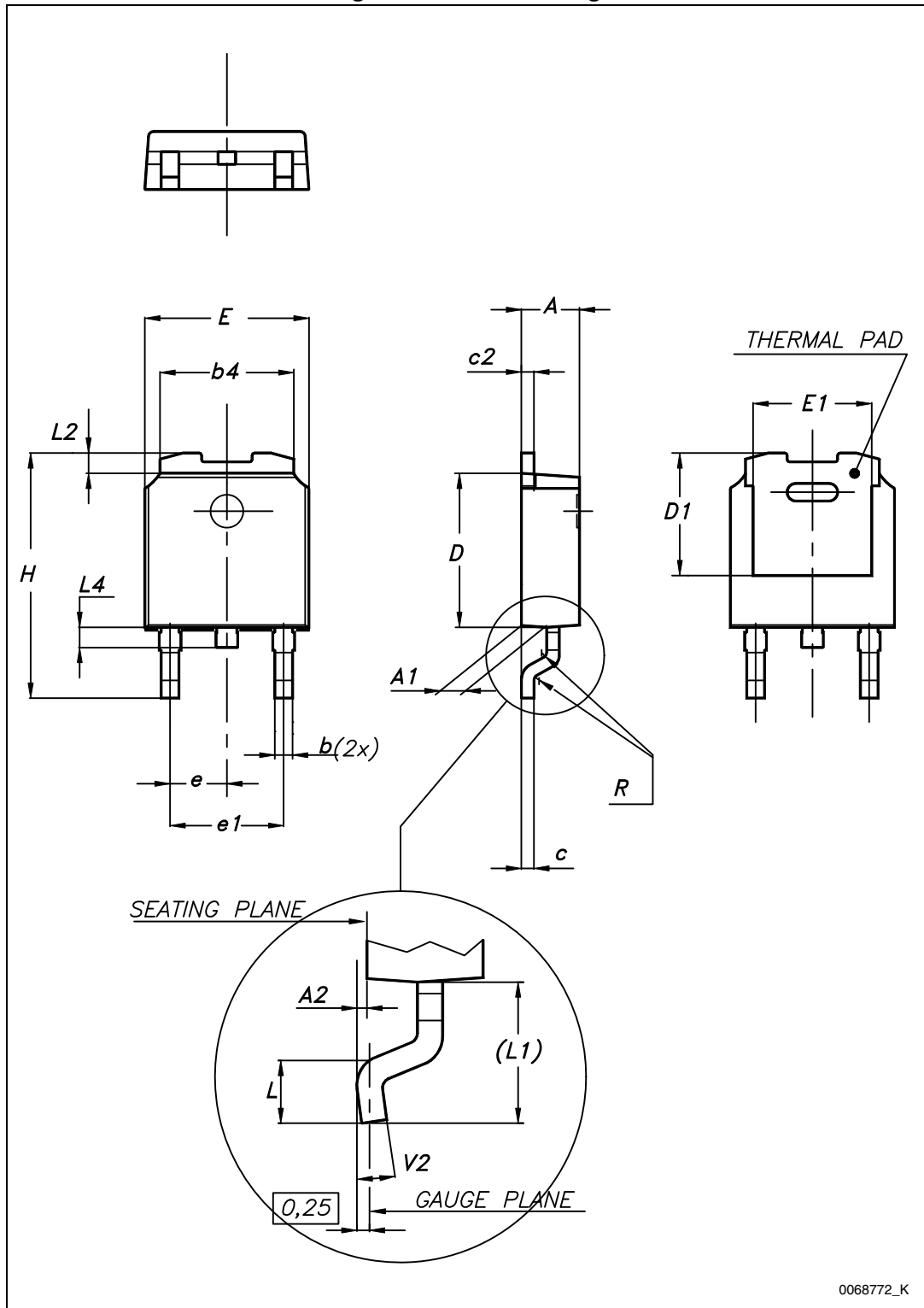
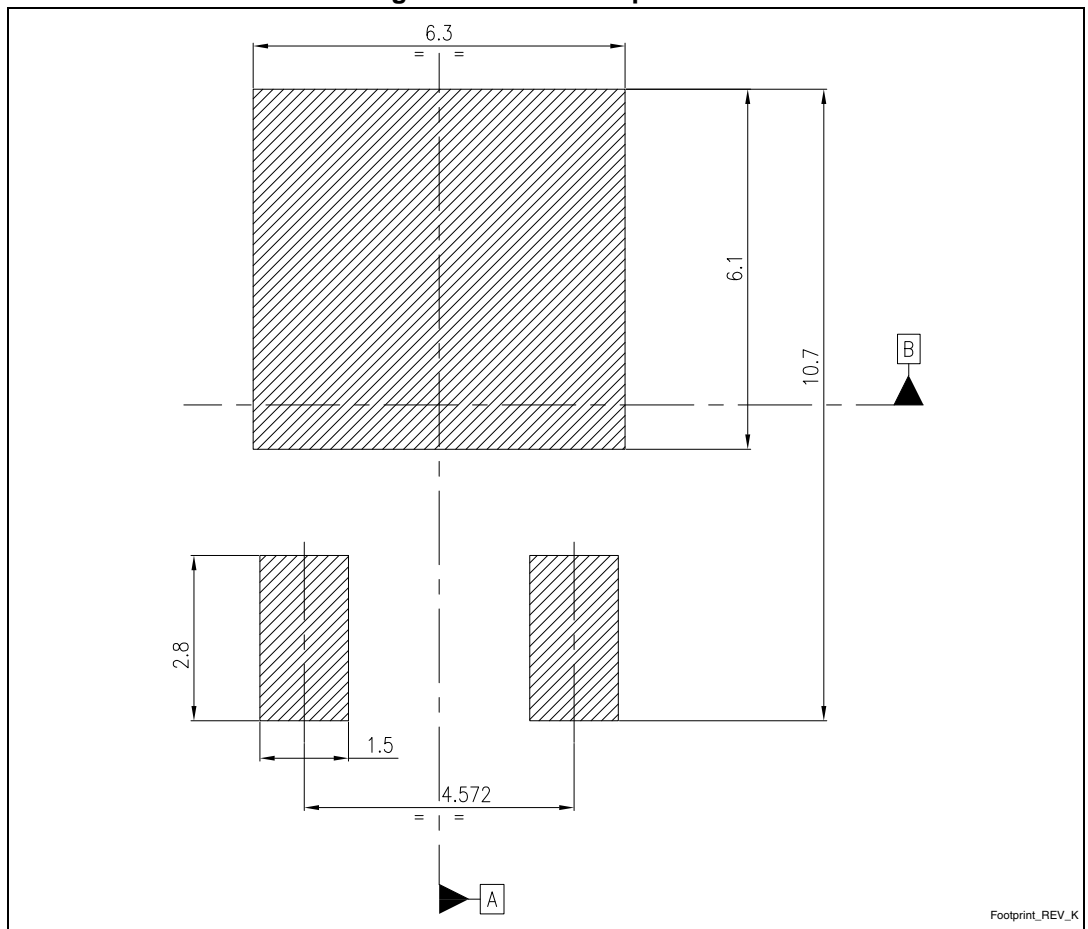

Table 6. DPAK mechanical data

Dim.	mm		
	Min.	Typ.	Max.
A	2.20		2.40
A1	0.90		1.10
A2	0.03		0.23
b	0.64		0.90
b4	5.20		5.40
c	0.45		0.60
c2	0.48		0.60
D	6.00		6.20
D1		5.10	
E	6.40		6.60
E1		4.70	
e		2.28	
e1	4.40		4.60
H	9.35		10.10
L	1.00		1.50
(L1)		2.80	
L2		0.80	
L4	0.60		1.00
R		0.20	
V2	0°		8°

Figure 20. DPAK footprint (a)



a. All dimensions are in millimeters.

Figure 21. PPAK drawing

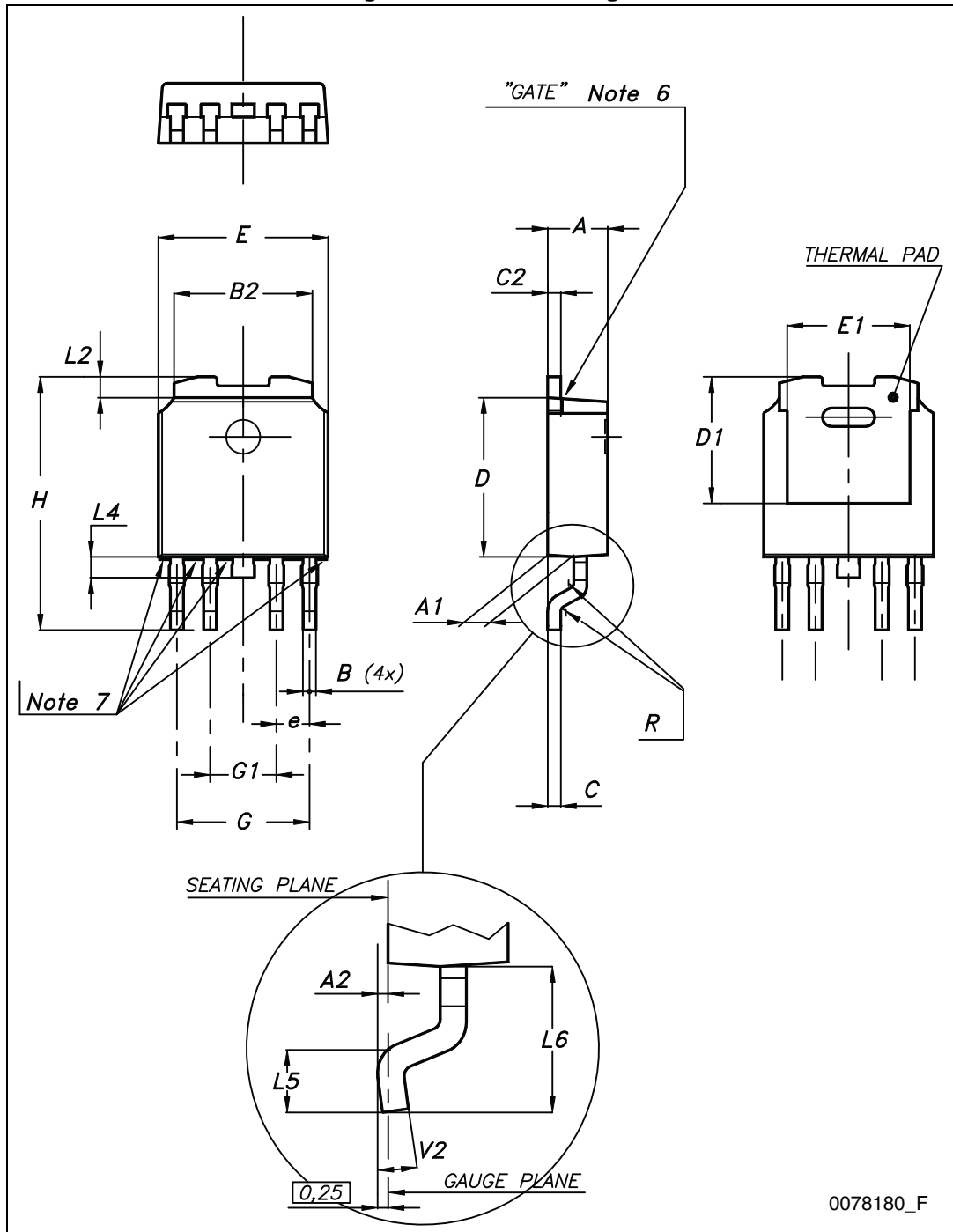

Table 7. PPAK mechanical data

Dim.	mm		
	Min.	Typ.	Max.
A	2.2		2.4
A1	0.9		1.1
A2	0.03		0.23
B	0.4		0.6
B2	5.2		5.4
C	0.45		0.6
C2	0.48		0.6
D	6		6.2
D1		5.1	
E	6.4		6.6
E1		4.7	
e		1.27	
G	4.9		5.25
G1	2.38		2.7
H	9.35		10.1
L2		0.8	1
L4	0.6		1
L5	1		
L6		2.8	
R		0.20	
V2	0°		8°

9 Packaging mechanical data

Figure 22. PPAK and DPAK tape

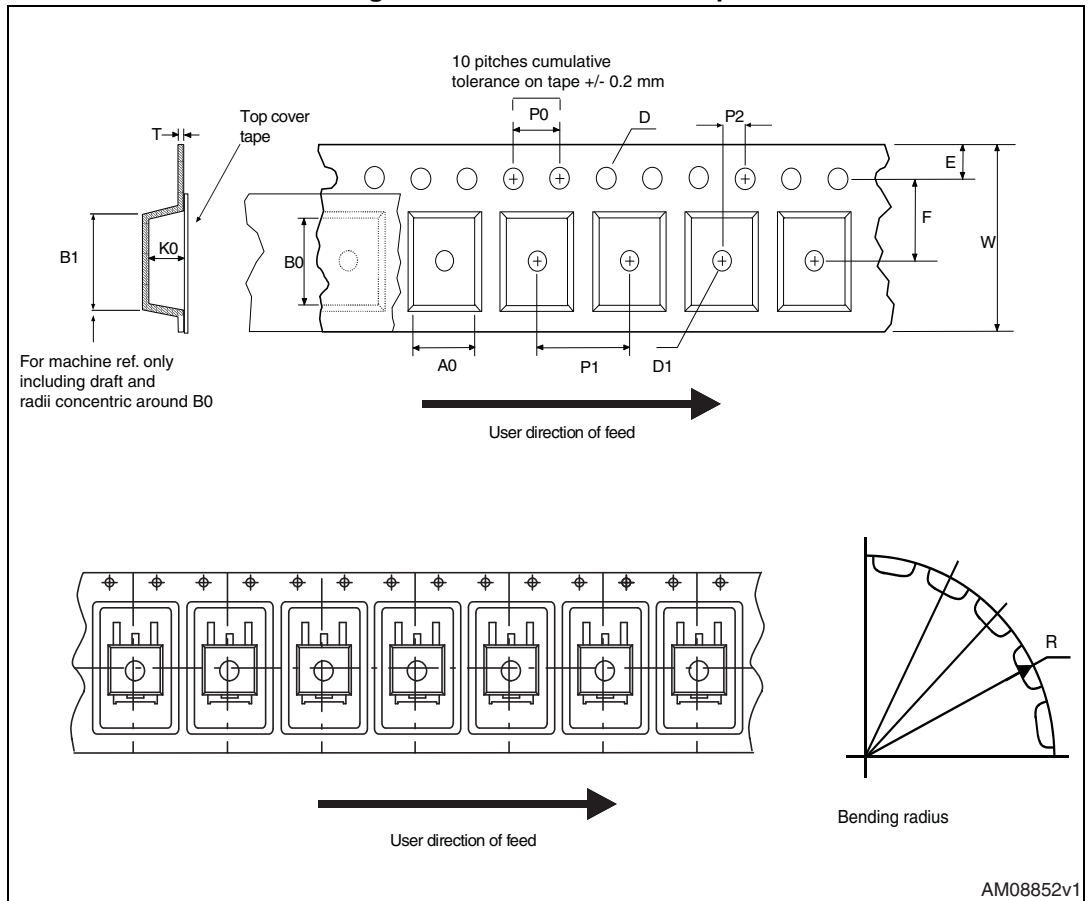

Figure 23. PPAK and DPAK reel

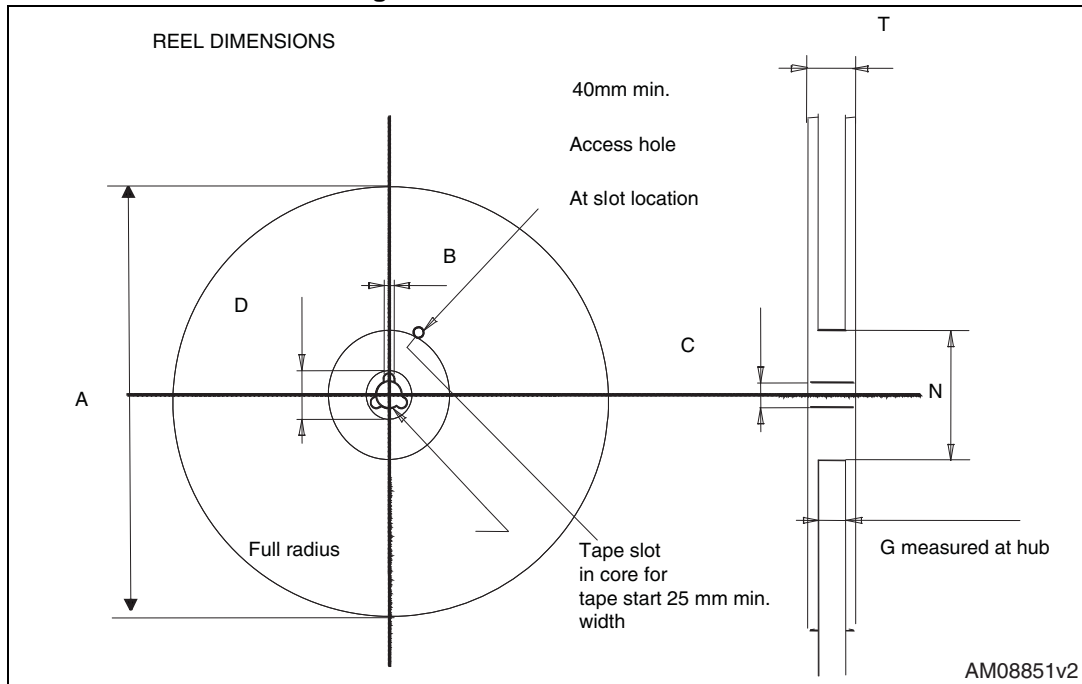

Table 8. PPAK and DPAK tape and reel mechanical data

Tape			Reel		
Dim.	mm		Dim.	mm	
	Min.	Max.		Min.	Max.
A0	6.8	7	A		330
B0	10.4	10.6	B	1.5	
B1		12.1	C	12.8	13.2
D	1.5	1.6	D	20.2	
D1	1.5		G	16.4	18.4
E	1.65	1.85	N	50	
F	7.4	7.6	T		22.4
K0	2.55	2.75			
P0	3.9	4.1		Base qty.	2500
P1	7.9	8.1		Bulk qty.	2500
P2	1.9	2.1			
R	40				
T	0.25	0.35			
W	15.7	16.3			

10 Revision history

Table 9. Document revision history

Date	Revision	Changes
26-Jan-2007	1	Initial release.
04-Jun-2014	2	Updated Table 1: Device summary , Table 2: Pin description and Section 8: Package mechanical data . Added Section 9: Packaging mechanical data . Minor text changes.

Please Read Carefully:

Information in this document is provided solely in connection with ST products. STMicroelectronics NV and its subsidiaries ("ST") reserve the right to make changes, corrections, modifications or improvements, to this document, and the products and services described herein at any time, without notice.

All ST products are sold pursuant to ST's terms and conditions of sale.

Purchasers are solely responsible for the choice, selection and use of the ST products and services described herein, and ST assumes no liability whatsoever relating to the choice, selection or use of the ST products and services described herein.

No license, express or implied, by estoppel or otherwise, to any intellectual property rights is granted under this document. If any part of this document refers to any third party products or services it shall not be deemed a license grant by ST for the use of such third party products or services, or any intellectual property contained therein or considered as a warranty covering the use in any manner whatsoever of such third party products or services or any intellectual property contained therein.

UNLESS OTHERWISE SET FORTH IN ST'S TERMS AND CONDITIONS OF SALE ST DISCLAIMS ANY EXPRESS OR IMPLIED WARRANTY WITH RESPECT TO THE USE AND/OR SALE OF ST PRODUCTS INCLUDING WITHOUT LIMITATION IMPLIED WARRANTIES OF MERCHANTABILITY, FITNESS FOR A PARTICULAR PURPOSE (AND THEIR EQUIVALENTS UNDER THE LAWS OF ANY JURISDICTION), OR INFRINGEMENT OF ANY PATENT, COPYRIGHT OR OTHER INTELLECTUAL PROPERTY RIGHT.

ST PRODUCTS ARE NOT DESIGNED OR AUTHORIZED FOR USE IN: (A) SAFETY CRITICAL APPLICATIONS SUCH AS LIFE SUPPORTING, ACTIVE IMPLANTED DEVICES OR SYSTEMS WITH PRODUCT FUNCTIONAL SAFETY REQUIREMENTS; (B) AERONAUTIC APPLICATIONS; (C) AUTOMOTIVE APPLICATIONS OR ENVIRONMENTS, AND/OR (D) AEROSPACE APPLICATIONS OR ENVIRONMENTS. WHERE ST PRODUCTS ARE NOT DESIGNED FOR SUCH USE, THE PURCHASER SHALL USE PRODUCTS AT PURCHASER'S SOLE RISK, EVEN IF ST HAS BEEN INFORMED IN WRITING OF SUCH USAGE, UNLESS A PRODUCT IS EXPRESSLY DESIGNATED BY ST AS BEING INTENDED FOR "AUTOMOTIVE, AUTOMOTIVE SAFETY OR MEDICAL" INDUSTRY DOMAINS ACCORDING TO ST PRODUCT DESIGN SPECIFICATIONS. PRODUCTS FORMALLY ESCC, QML OR JAN QUALIFIED ARE DEEMED SUITABLE FOR USE IN AEROSPACE BY THE CORRESPONDING GOVERNMENTAL AGENCY.

Resale of ST products with provisions different from the statements and/or technical features set forth in this document shall immediately void any warranty granted by ST for the ST product or service described herein and shall not create or extend in any manner whatsoever, any liability of ST.

ST and the ST logo are trademarks or registered trademarks of ST in various countries.

Information in this document supersedes and replaces all information previously supplied.

The ST logo is a registered trademark of STMicroelectronics. All other names are the property of their respective owners.

© 2014 STMicroelectronics - All rights reserved

STMicroelectronics group of companies

Australia - Belgium - Brazil - Canada - China - Czech Republic - Finland - France - Germany - Hong Kong - India - Israel - Italy - Japan - Malaysia - Malta - Morocco - Philippines - Singapore - Spain - Sweden - Switzerland - United Kingdom - United States of America

www.st.com

