

Demonstration board for L6235 DMOS driver for 3-phase brushless DC motor

Data brief

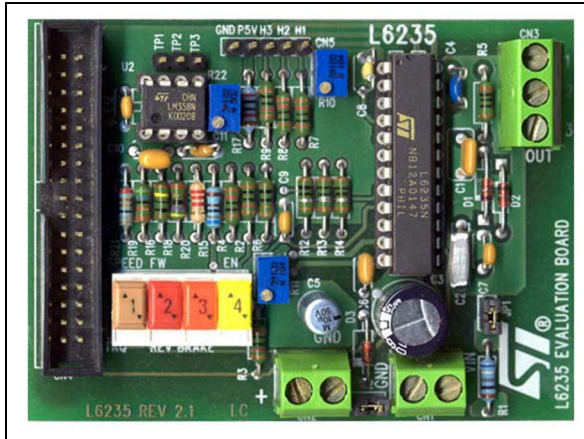

Description

The L6235 device is a DMOS fully integrated 3-phase motor driver with overcurrent protection.

Realized in BCD technology, the device combines isolated DMOS power transistors with CMOS and bipolar circuits on the same chip.

The device includes all the circuitry needed to drive a 3-phase BLDC motor including: a 3-phase DMOS bridge, a constant off-time PWM current controller and the decoding logic for single ended hall sensors that generates the required sequence for the power stage.

Available in a PowerDIP24 (20 + 2 + 2) package, the L6235 device features non-dissipative overcurrent protection on the high-side power MOSFETs and the thermal shutdown.

Features

- Operating supply voltage from 8 to 52 V
- 5.6 A output peak current (2.8 A DC)
- $R_{DS(ON)}$ 0.3 Ω typ. value at $T_j = 25^\circ\text{C}$
- Operating frequency up to 100 KHz
- Non-dissipative overcurrent detection and protection
- Diagnostic output
- Constant t_{OFF} PWM current controller
- Slow decay synchronous rectification
- 60° and 120° hall effect decoding logic
- Brake function
- Tachometer output for speed loop
- Cross-conduction protection
- Thermal shutdown
- Undervoltage lockout
- Integrated fast freewheeling diodes

1 Schematic diagram

Figure 1. EVAl6235N circuit schematic

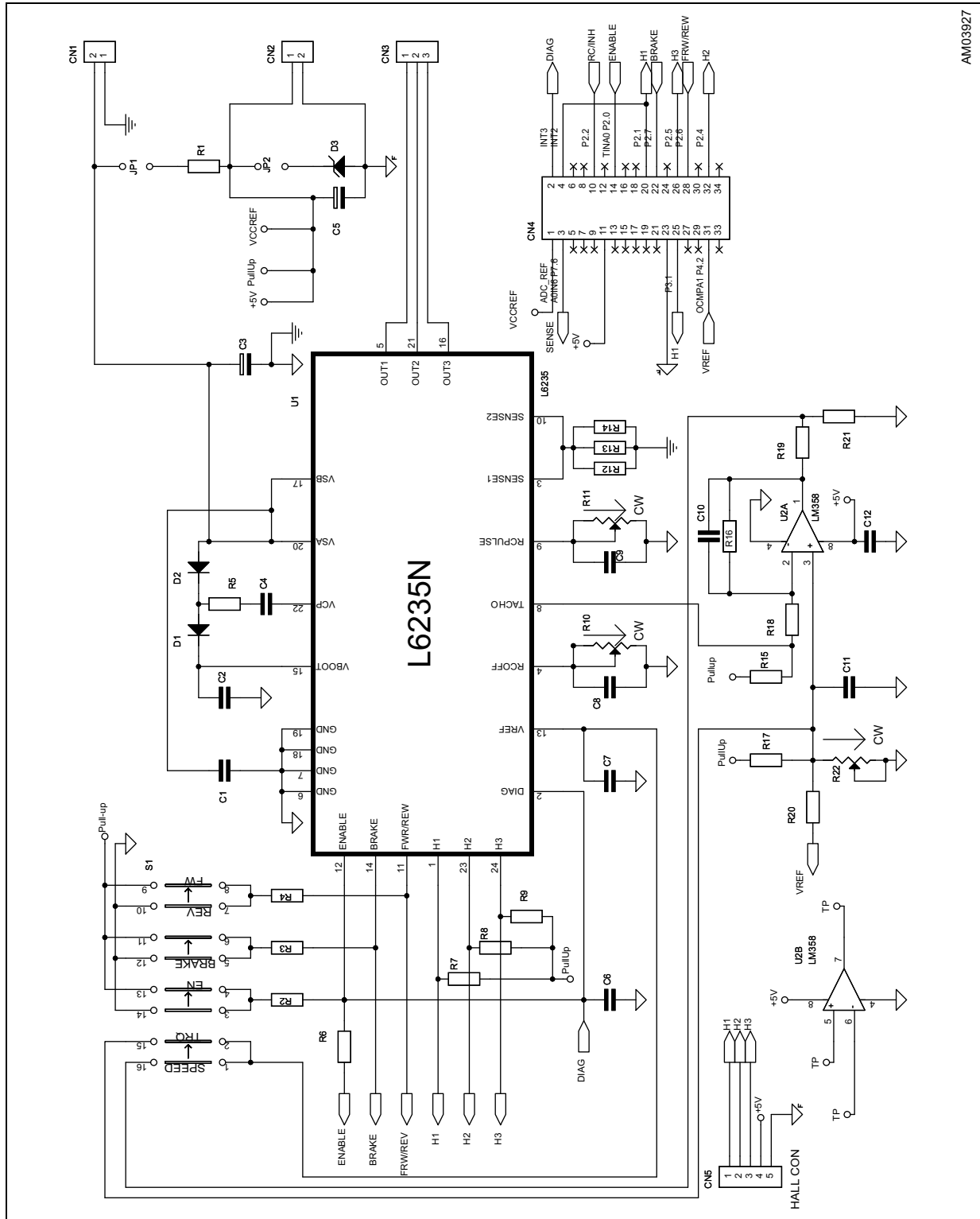

AM03927



2 Bill of material

Table 1. EVAL6235N - bill of material

Part reference	Part value	Part description
CN1, CN2	2P screw connector	2-pole screw connector
CN3	3P screw connector	3-pole screw connector
CN4	CON34A FLAT 17 x 2	34-pin flat cable
CN5	5 x 1 strip connector	5-pin strip connector P2.54
C1	220 nF / 100 V	Ceramic capacitor
C2	220 nF / 100 V	Polyester capacitor
C3	100 μ F / 63 V	Electrolytic capacitor P5
C4	10 nF / 100 V	Ceramic capacitor
C5	10 μ F / 16 V	Electrolytic capacitor P1.5
C6	5.6 nF	Ceramic capacitor
C7	1 nF	Ceramic capacitor
C8	820 pF	Ceramic capacitor
C9	10 nF	Ceramic capacitor
C10	220 nF	Ceramic capacitor
C11	68 nF	Ceramic capacitor
C12	100 nF	Ceramic capacitor
D1, D2	1N4448	High speed switching diodes
D3	BZX79C5V1	5.1 V Zener diode
JP1, JP2	CLOSE	Jumper
R1	700 Ω / 0.6 W	Resistor
R2	330 k Ω / 0.25 W	Resistor
R3, R4, R7, R8, R9	10 k Ω / 0.25 W / 5%	Resistor
R5	100 Ω / 0.25 W / 5%	Resistor
R6	56 k Ω / 0.25 W	Resistor
R10, R11	Spectrol 74 W - 104	Trimmer 100 k Ω
R12, R13, R14	1 Ω / 0.4 W	Resistor
R15	1 k Ω / 0.25 W	Resistor
R16	1 M Ω	Resistor
R17	20 k Ω / 0.25 W / 1%	Resistor
R18	4.7 k Ω / 0.25 W	Resistor
R19	5.6 k Ω / 0.25 W / 1%	Resistor
R20	2.2 k Ω	Resistor

Table 1. EVAL6235N - bill of material (continued)

Part reference	Part value	Part description
R21	1.8 k Ω / 0.25 W / 1%	Resistor
R22	Spectrol 74W-502	Trimmer 5 k Ω
S1	Quad switch	Quadruple switch 2 position
U1	L6235	3-phase BLDC DMOS motor driver
U2	LM358	Dual operational amplifier

3 PCB layout

Figure 2. EVAL6235N - layout (component placement view)

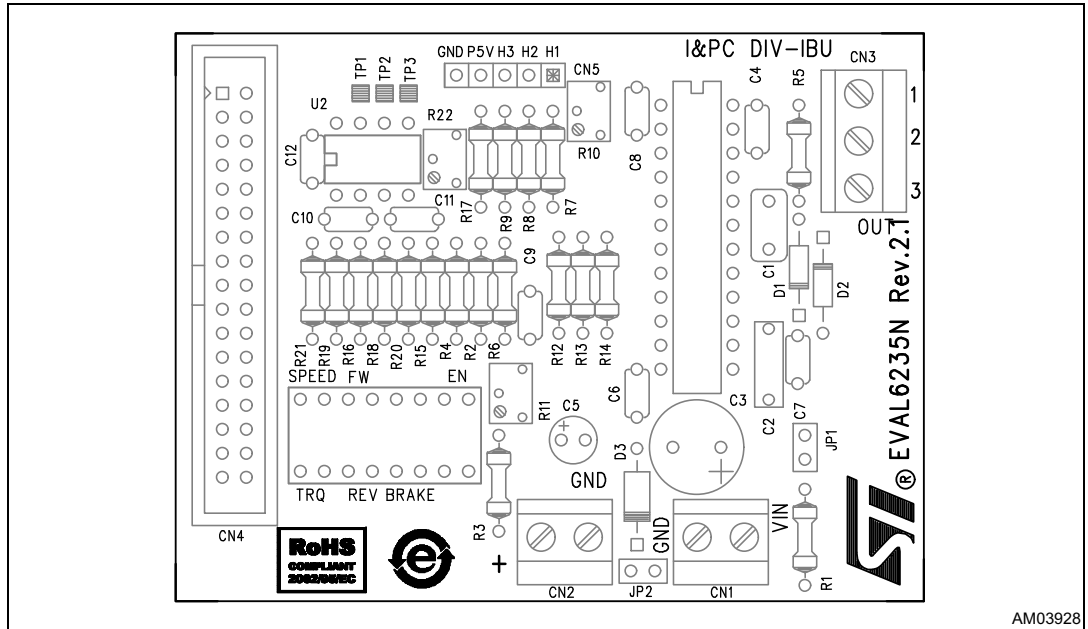

Figure 3. EVAL6235N - layout (top layer)

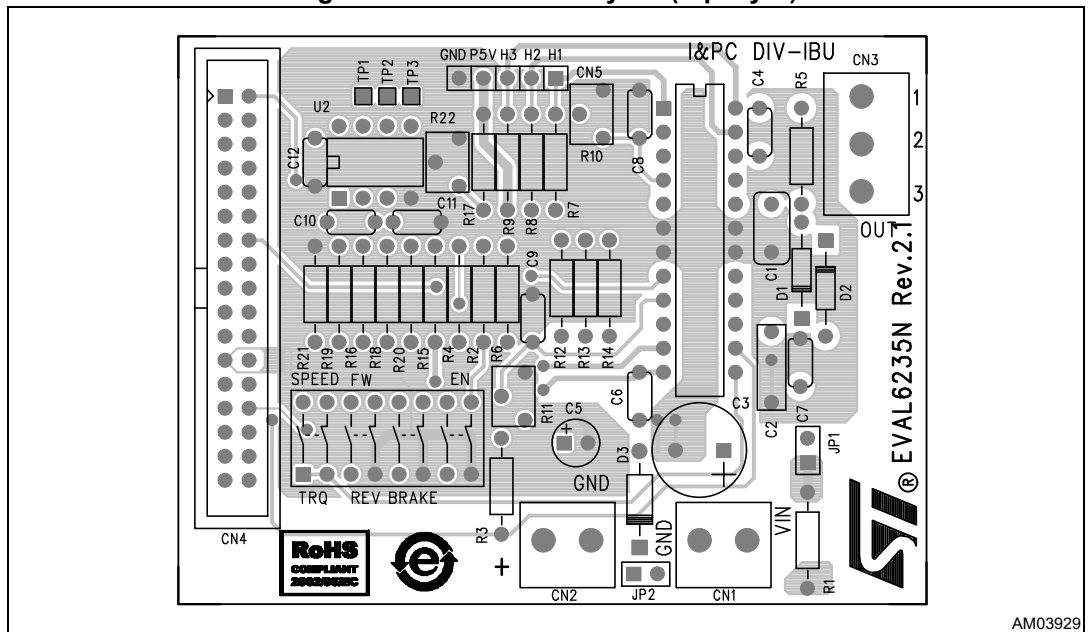
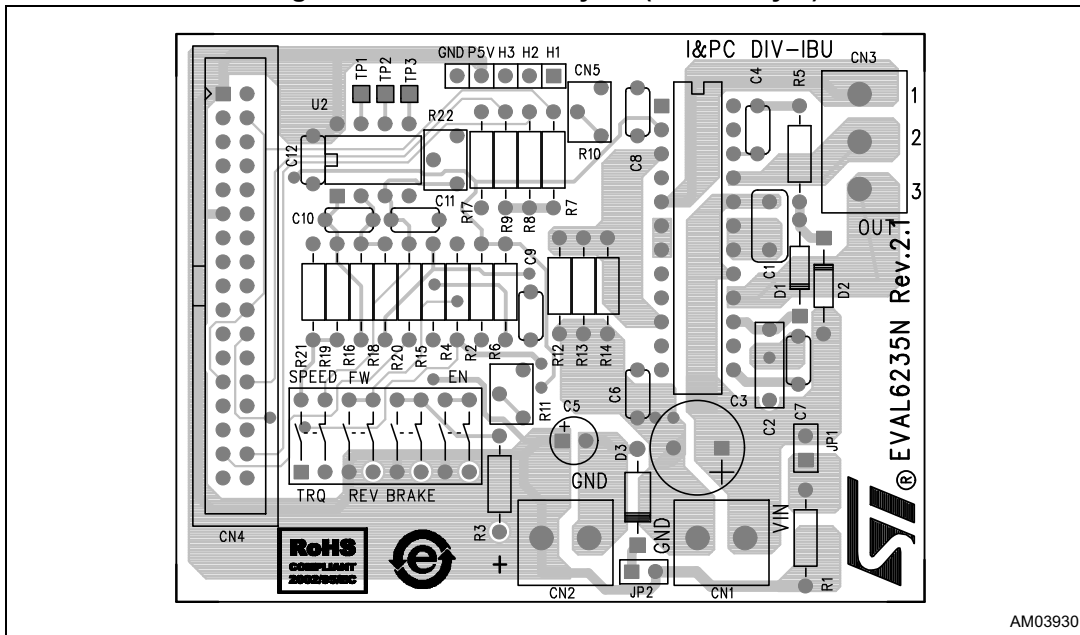

Figure 4. EVAL6235N - layout (bottom layer)



4 Revision history

Table 2. Document revision history

Date	Revision	Changes
09-Apr-2015	1	Initial release.

IMPORTANT NOTICE – PLEASE READ CAREFULLY

STMicroelectronics NV and its subsidiaries ("ST") reserve the right to make changes, corrections, enhancements, modifications, and improvements to ST products and/or to this document at any time without notice. Purchasers should obtain the latest relevant information on ST products before placing orders. ST products are sold pursuant to ST's terms and conditions of sale in place at the time of order acknowledgement.

Purchasers are solely responsible for the choice, selection, and use of ST products and ST assumes no liability for application assistance or the design of Purchasers' products.

No license, express or implied, to any intellectual property right is granted by ST herein.

Resale of ST products with provisions different from the information set forth herein shall void any warranty granted by ST for such product.

ST and the ST logo are trademarks of ST. All other product or service names are the property of their respective owners.

Information in this document supersedes and replaces information previously supplied in any prior versions of this document.

© 2015 STMicroelectronics – All rights reserved