

High-voltage, high-side current sense amplifier

Datasheet - production data

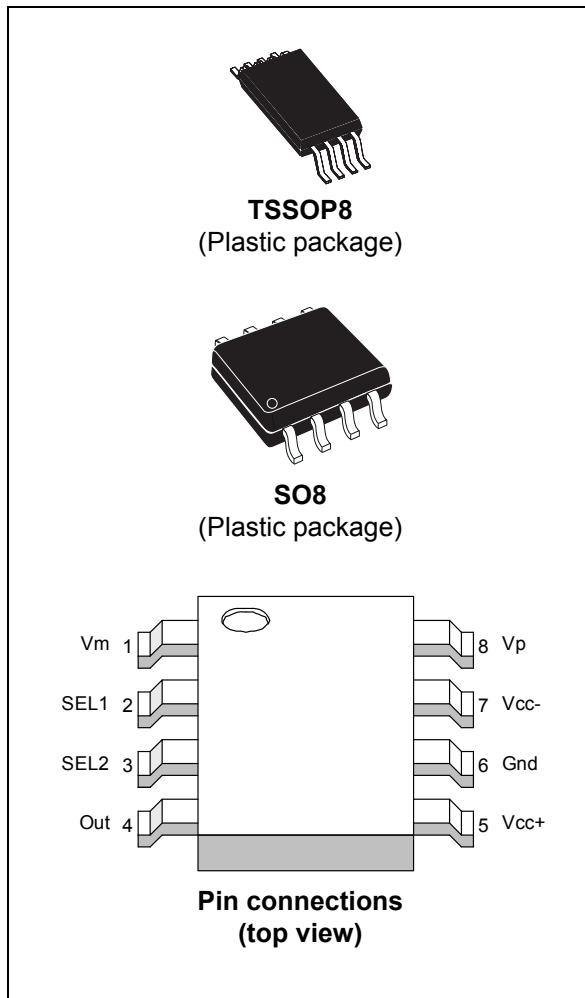

- Supply voltage range: 2.7 to 5.5 V in single-supply configuration
- Low current consumption: I_{CC} max = 360 μ A
- Pin selectable gain: 20 V/V, 25 V/V, 50 V/V or 100 V/V
- Buffered output

Applications

- Automotive current monitoring
- DC motor control
- Photo-voltaic systems
- Battery chargers
- Precision current sources
- Current monitoring of notebook computers
- Uninterruptible power supplies
- High-end power supplies

Description

The TSC103 measures a small differential voltage on a high-side shunt resistor and translates it into a ground-referenced output voltage. The gain is adjustable to four different values from 20 V/V up to 100 V/V by two selection pins.

Wide input common-mode voltage range, low quiescent current, and tiny TSSOP8 packaging enable use in a wide variety of applications.

The input common-mode and power-supply voltages are independent. The common-mode voltage can range from 2.9 V to 70 V in the single-supply configuration or be offset by an adjustable voltage supplied on the Vcc- pin in the dual-supply configuration.

With a current consumption lower than 360 μ A and a virtually null input leakage current in standby mode, the power consumption in the applications is minimized.

Features

- Independent supply and input common-mode voltages
- Wide common-mode operating range: 2.9 V to 70 V in single-supply configuration, -2.1 V to 65 V in dual-supply configuration
- Wide common-mode surviving range: -16 V to 75 V (reversed battery and load-dump conditions)

Contents

1	Application schematic and pin description	3
2	Absolute maximum ratings and operating conditions	6
3	Electrical characteristics	7
4	Electrical characteristics curves: current sense amplifier	10
5	Parameter definitions	13
5.1	Common-mode rejection ratio (CMR)	13
5.2	Supply voltage rejection ratio (SVR)	13
5.3	Gain (A_v) and input offset voltage (V_{OS})	13
5.4	Output voltage drift versus temperature	15
5.5	Input offset drift versus temperature	16
5.6	Output voltage accuracy	16
6	Maximum permissible voltages on pins	18
7	Application information	19
8	Package information	21
8.1	TSSOP8 package information	22
8.2	SO8 package information	23
9	Ordering information	24
10	Revision history	24

1 Application schematic and pin description

The TSC103 high-side current sense amplifier can be used in either single- or dual-supply mode. In the single-supply configuration, the TSC103 features a wide 2.9 V to 70 V input common-mode range totally independent of the supply voltage. In the dual-supply range, the common-mode range is shifted by the value of the negative voltage applied on the Vcc- pin. For instance, with Vcc+ = 5 V and Vcc- = -5 V, then the input common-mode range is -2.1 V to 65 V.

Figure 1. Single-supply configuration schematic

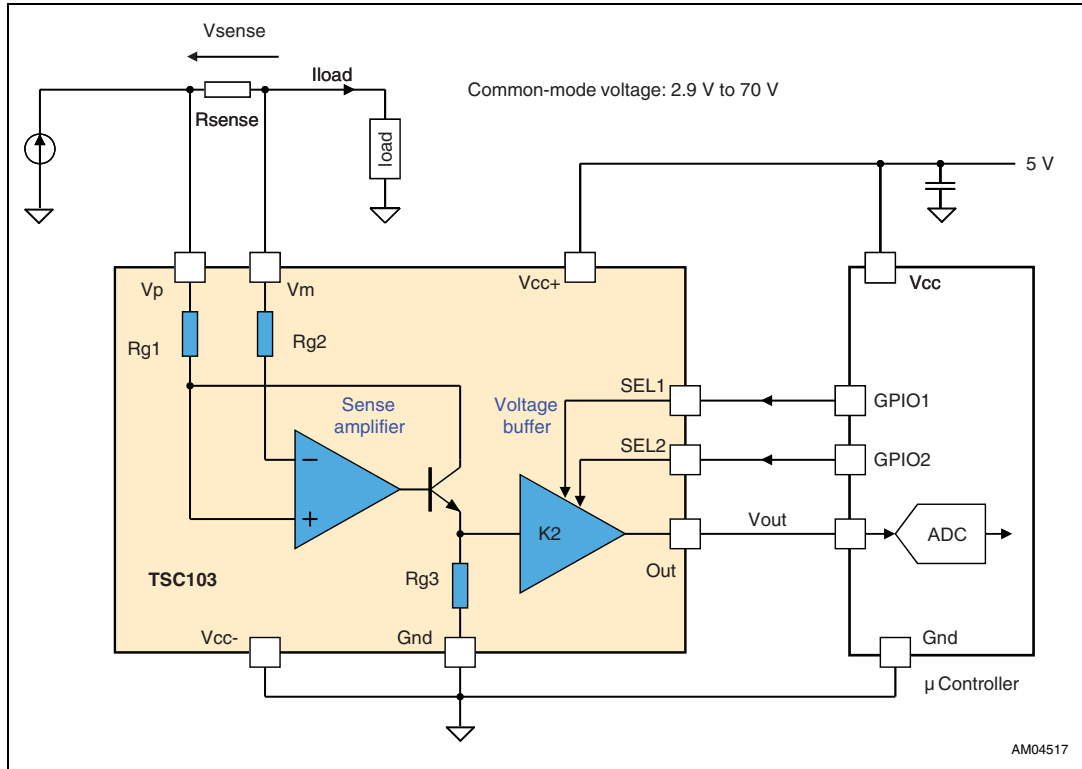

AM04517

Figure 2. Dual-supply configuration schematic

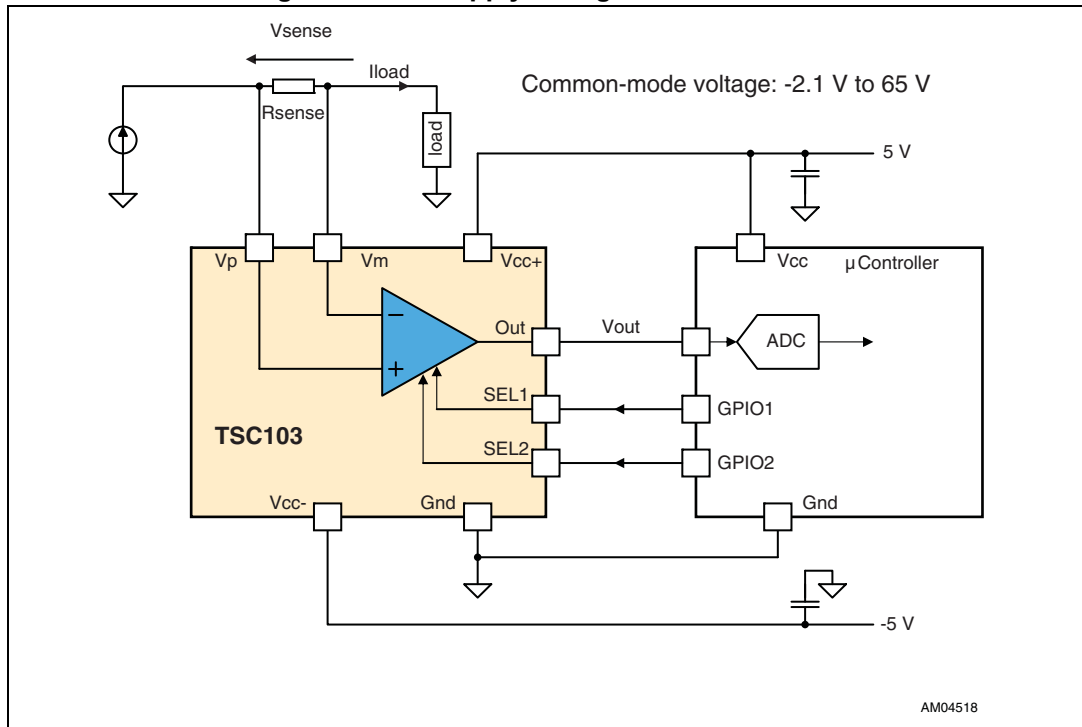
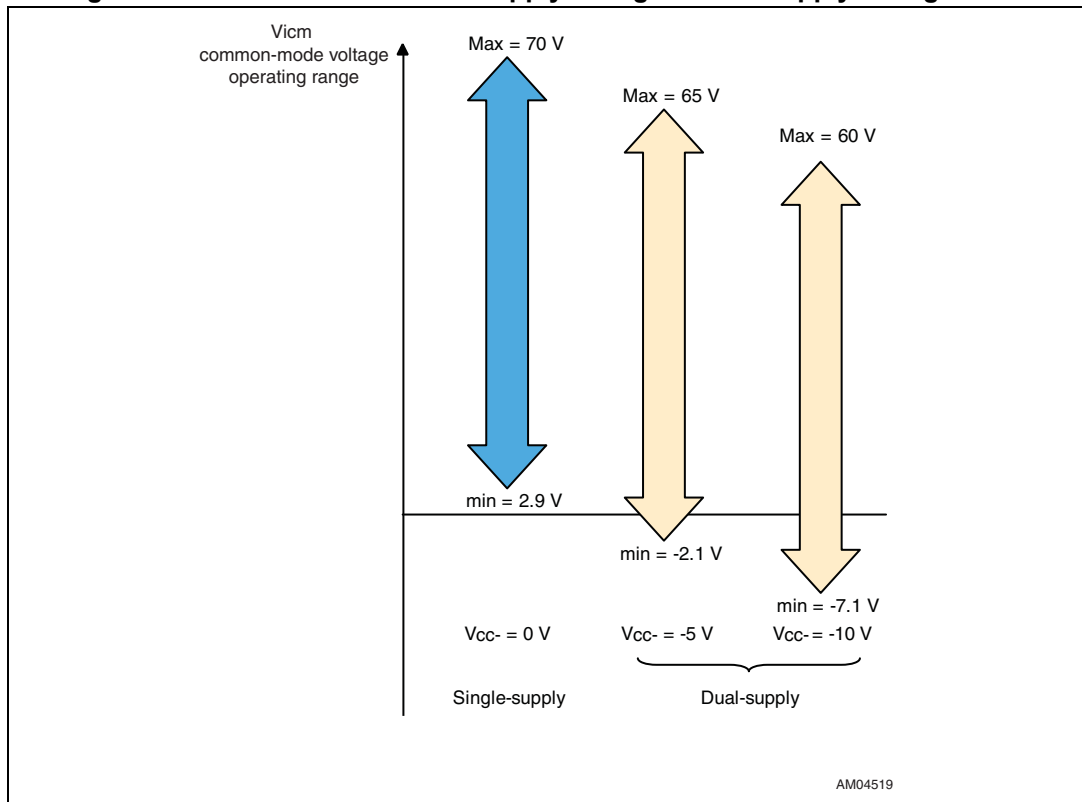

Figure 3. Common-mode versus supply voltage in dual-supply configuration



[Table 1](#) describes the function of each pin. Their position is shown in the illustration on the cover page and in [Figure 1 on page 3](#).

Table 1. Pin description

Symbol	Type	Function
Out	Analog output	The Out voltage is proportional to the magnitude of the sense voltage V_p - V_m .
Gnd	Power supply	Ground line
Vcc+		Positive power supply line.
Vcc-		Negative power supply line.
Vp	Analog input	Connection for the external sense resistor. The measured current enters the shunt on the V_p side.
Vm		Connection for the external sense resistor. The measured current exits the shunt on the V_m side.
SEL1	Digital input	Gain-select pin
SEL2		

2 Absolute maximum ratings and operating conditions

Table 2. Absolute maximum ratings

Symbol	Parameter	Value	Unit
V_{id}	Input pins differential voltage ($V_p - V_m$)	± 20	V
V_{in_sense}	Sensing pins input voltages (V_p, V_m) ⁽¹⁾	-16 to 75	
V_{in_sel}	Gain selection pins input voltages (SEL1, SEL2) ⁽²⁾	-0.3 to $V_{CC+} + 0.3$	
V_{CC+}	Positive supply voltage ⁽²⁾	-0.3 to 7	
$V_{CC+} - V_{CC-}$	DC supply voltage	0 to 15	
V_{out}	DC output pin voltage ⁽²⁾	-0.3 to $V_{CC+} + 0.3$	
T_{stg}	Storage temperature	-55 to 150	°C
T_j	Maximum junction temperature	150	
R_{thja}	TSSOP8 thermal resistance junction to ambient	120	°C/W
	SO8 thermal resistance junction to ambient	125	
ESD	HBM: human body model ⁽³⁾	2.5	kV
	MM: machine model ⁽⁴⁾	150	V
	CDM: charged device model ⁽⁵⁾	1.5	kV

1. These voltage values are measured with respect to the V_{CC-} pin.
2. These voltage values are measured with respect to the Gnd pin.
3. Human body model: a 100 pF capacitor is charged to the specified voltage, then discharged through a 1.5 kΩ resistor between two pins of the device. This is done for all couples of connected pin combinations while the other pins are floating.
4. Machine model: a 200 pF capacitor is charged to the specified voltage, then discharged directly between two pins of the device with no external series resistor (internal resistor < 5 Ω). This is done for all couples of connected pin combinations while the other pins are floating.
5. Charged device model: all pins plus package are charged together to the specified voltage and then discharged directly to ground.

Table 3. Operating conditions

Symbol	Parameter	Value	Unit
V_{CC+}	Supply voltage in single-supply configuration from T_{min} to T_{max} (V_{CC-} connected to Gnd = 0 V)	2.7 to 5.5	V
V_{CC-}	Negative supply voltage in dual-supply configuration from T_{min} to T_{max}	-	V
	$V_{CC+} = 5.5$ V max	-8 to 0	
	$V_{CC+} = 3$ V max	-11 to 0	
V_{icm}	Common-mode voltage range referred to pin V_{CC-} (T_{min} to T_{max})	2.9 to 70	V
T_{oper}	Operational temperature range (T_{min} to T_{max})	-40 to 125	°C

3 Electrical characteristics

The electrical characteristics given in the following tables are measured under the following test conditions unless otherwise specified.

- $T_{amb} = 25\text{ }^{\circ}\text{C}$, $V_{CC+} = 5\text{ V}$, V_{CC-} connected to Gnd (single-supply configuration).
- $V_{sense} = V_p - V_m = 50\text{ mV}$, $V_m = 12\text{ V}$, no load on Out, all gain configurations.

Table 4. Supply

Symbol	Parameter	Test conditions	Min.	Typ.	Max.	Unit
I_{CC}	Total supply current	$V_{sense} = 0\text{ V}$, $T_{min} < T_{amb} < T_{max}$		200	360	μA
I_{CC1}	Total supply current	$V_{sense} = 50\text{ mV}$ $A_v = 50\text{ V/V}$ $T_{min} < T_{amb} < T_{max}$	-	300	480	

Table 5. Input

Symbol	Parameter	Test conditions	Min.	Typ.	Max.	Unit
DC CMR	DC common-mode rejection Variation of V_{out} versus V_{icm} referred to input ⁽¹⁾	$2.9\text{ V} < V_m < 70\text{ V}$ $T_{min} < T_{amb} < T_{max}$	90	105		dB
AC CMR	AC common-mode rejection Variation of V_{out} versus V_{icm} referred to input (peak-to-peak voltage variation)	$A_v = 50\text{ V/V}$ or 100 V/V $2.9\text{ V} < V_m < 30\text{ V}$ 1 kHz sine wave		95		
SVR	Supply voltage rejection Variation of V_{out} versus V_{CC} ⁽²⁾ SEL1 = Gnd, SEL2 = Gnd	$2.7\text{ V} < V_{CC} < 5.5\text{ V}$ $V_{sense} = 30\text{ mV}$ $T_{min} < T_{amb} < T_{max}$	85	95		
V_{os}	Input offset voltage ⁽³⁾	$T_{amb} = 25\text{ }^{\circ}\text{C}$ $T_{min} < T_{amb} < T_{max}$			± 500 ± 1100	μV
dV_{os}/dT	Input offset drift vs. T	$A_v = 50\text{ V/V}$ $T_{min} < T_{amb} < T_{max}$	-20		+5	$\mu\text{V}/^{\circ}\text{C}$
I_{lk}	Input leakage current	$V_{CC} = 0\text{ V}$ $T_{min} < T_{amb} < T_{max}$			1	μA
I_{ib}	Input bias current	$V_{sense} = 0\text{ V}$ $T_{min} < T_{amb} < T_{max}$		10	15	
V_{IL}	Logic low voltage threshold (SEL1 and SEL2)	$V_{CCmin} < V_{CC} < V_{CCmax}$ $T_{min} < T_{amb} < T_{max}$	-0.3		0.5	V
V_{IH}	Logic high voltage threshold (SEL1 and SEL2)	$V_{CCmin} < V_{CC} < V_{CCmax}$ $T_{min} < T_{amb} < T_{max}$	1.2		V_{CC}	
I_{sel}	Gain-select pins (SEL1 and SEL2) input bias current	SEL pin connected to GND or V_{CC} $T_{min} < T_{amb} < T_{max}$		400		nA

1. See [Section 5: Parameter definitions](#) for the definition of CMR.
2. See [Section 5](#) for the definition of SVR.
3. See [Section 5](#) for the definition of V_{os} .

Table 6. Output

Symbol	Parameter	Test conditions	Min.	Typ.	Max.	Unit
A_v	Gain	SEL1 = Gnd, SEL2 = Gnd SEL1 = Gnd, SEL2 = Vcc+ SEL1 = Vcc+, SEL2 = Gnd SEL1 = Vcc+, SEL2 = Vcc+		20 25 50 100		V/V
$\Delta V_{out}/\Delta T$	Output voltage drift vs. T ⁽¹⁾	$A_v = 50 \text{ V/V}$ $T_{min} < T_{amb} < T_{max}$			±240	ppm/°C
$\Delta V_{out}/\Delta I_{out}$	Output stage load regulation	-10 mA < I_{out} < 10 mA I_{out} sink or source current $A_v = 50 \text{ V/V}$		0.3	±1.5	mV/mA
ΔV_{out}	Total output voltage accuracy ⁽²⁾	$V_{sense} = 50 \text{ mV}^{(3)}$ $T_{amb} = 25 \text{ °C}$ $T_{min} < T_{amb} < T_{max}$			±2.5 ±4	%
ΔV_{out}	Total output voltage accuracy	$V_{sense} = 90 \text{ mV}^{(3)}$ $T_{amb} = 25 \text{ °C}$ $T_{min} < T_{amb} < T_{max}$			±3.5 ±5	
ΔV_{out}	Total output voltage accuracy	$V_{sense} = 20 \text{ mV}$ $T_{amb} = 25 \text{ °C}$ $T_{min} < T_{amb} < T_{max}$			±3.5 ±5	
ΔV_{out}	Total output voltage accuracy	$V_{sense} = 10 \text{ mV}$ $T_{amb} = 25 \text{ °C}$ $T_{min} < T_{amb} < T_{max}$			±5.5 ±8	
ΔV_{out}	Total output voltage accuracy	$V_{sense} = 5 \text{ mV}$ $T_{amb} = 25 \text{ °C}$ $T_{min} < T_{amb} < T_{max}$			±10 ±22	
I_{sc}	Short-circuit current	OUT connected to V _{CC} or GND	15	26		mA
V_{OH}	Output stage high-state saturation voltage $V_{OH} = V_{CC} - V_{out}$	$V_{sense} = 1 \text{ V}$ $I_{out} = 1 \text{ mA}$		85	135	mV
V_{OL}	Output stage low-state saturation voltage	$V_{sense} = -1 \text{ V}$ $I_{out} = 1 \text{ mA}$		80	125	

1. See [Section 5: Parameter definitions](#) for the definition of output voltage drift versus temperature.
2. Output voltage accuracy is the difference with the expected theoretical output voltage $V_{out-th} = A_v \cdot V_{sense}$. See [Section 5](#) for a more detailed definition.
3. Except for $A_v = 100 \text{ V/V}$.

Table 7. Frequency response

Symbol	Parameter	Test conditions	Min.	Typ.	Max.	Unit
t _s	Response to input differential voltage change. Output settling to 1% of final value	V _{sense} square pulse applied to generate a variation of V _{out} from 500 mV to 3 V C _{load} = 47 pF	-	-	-	μs
		Av = 20 V/V,	-	3	-	
		Av = 25 V/V	-	4	-	
		Av = 50 V/V	-	6	-	
		Av = 100 V/V	-	10	-	
t _{SEL}	Response to a gain change. Output settling to 1% of final value	Any change of state of SEL1 or SEL2 pin	-	1	-	μs
t _{rec}	Response to common-mode voltage change. Output settling to 1% of final value	V _{CC+} = 5 V, V _{CC-} = -5 V V _m step change from -2 V to 30 V or 30 V to -2 V	-	20	-	
SR	Slew rate	V _{sense} = 10 mV to 100 mV	0.4	0.6	-	V/μs
BW	3 dB bandwidth	C _{load} = 47 pF V _m = 12 V V _{sense} = 50 mV Av = 50 V/V	-	700	-	kHz

Table 8. Noise

Symbol	Parameter	Test conditions	Min.	Typ.	Max.	Unit
e _N	Equivalent input noise voltage	f = 1 kHz	-	40	-	nV/√Hz

4 Electrical characteristics curves: current sense amplifier

Unless otherwise specified, the test conditions for the following curves are:

- $T_{amb} = 25\text{ }^{\circ}\text{C}$, $V_{CC} = 5\text{ V}$, $V_{sense} = V_p - V_m = 50\text{ mV}$, $V_m = 12\text{ V}$
- No load on Out pin

Figure 4. Output voltage vs. V_{sense}

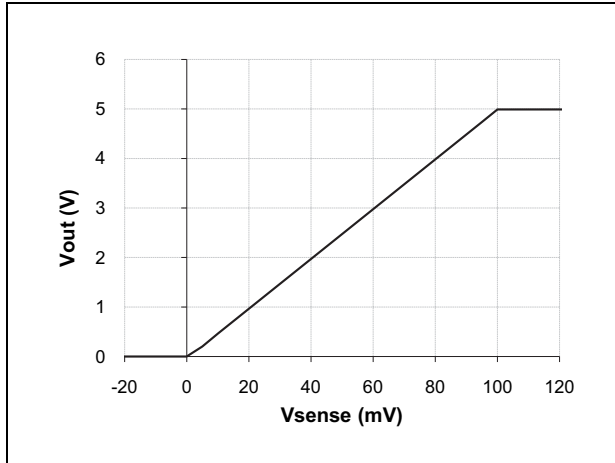

Figure 5. Output voltage accuracy vs. V_{sense}

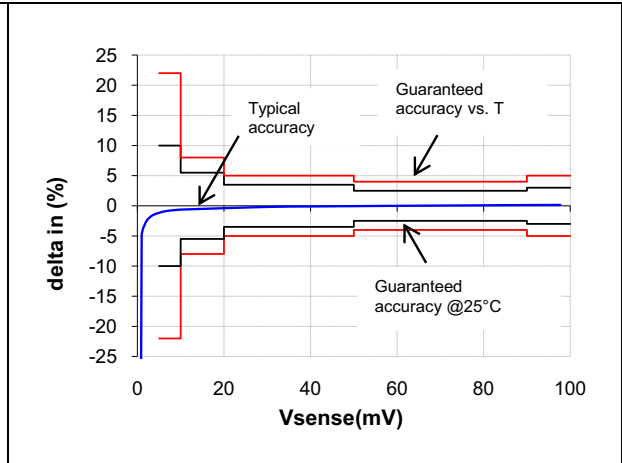

Figure 6. Supply current vs. supply voltage

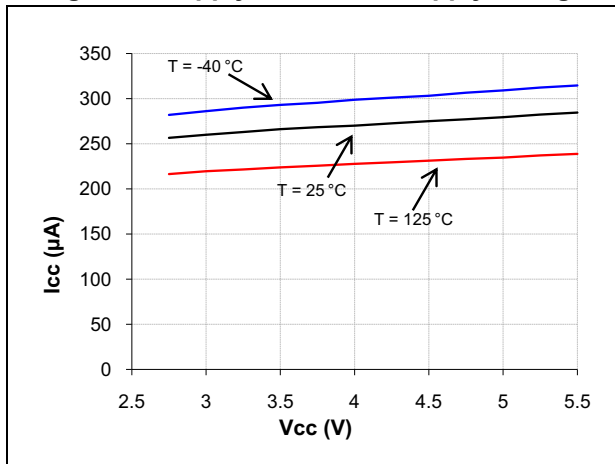

Figure 7. Supply current vs. V_{sense}

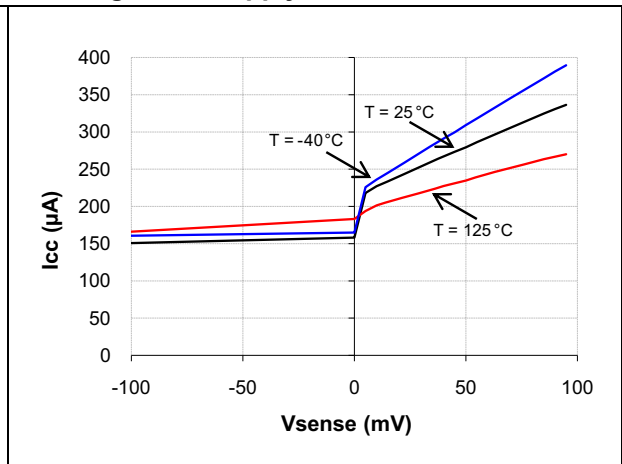

Figure 8. Vp pin input current vs. Vsense

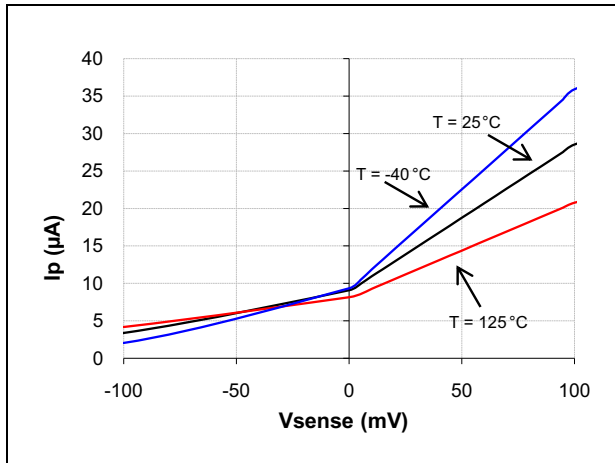

Figure 9. Vn pin input current vs. Vsense

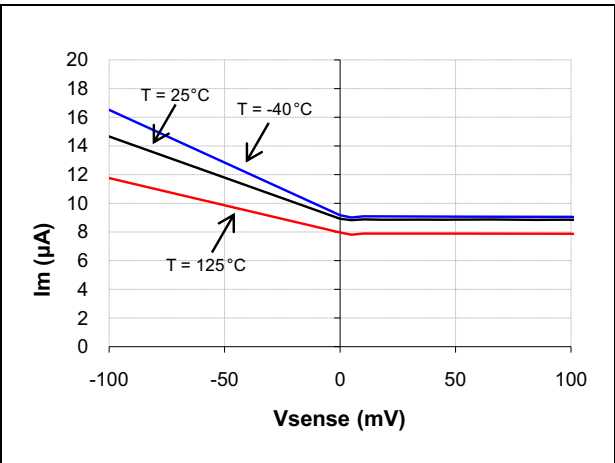

Figure 10. Output stage low-state saturation voltage vs. output current (Vsense = -1 V)

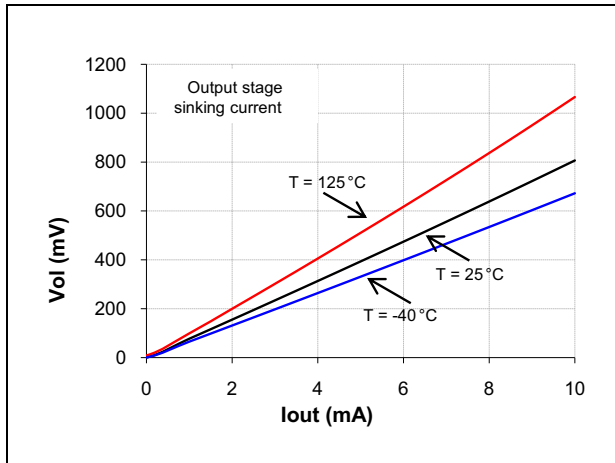

Figure 11. Output stage high-state saturation voltage vs. output current (Vsense = +1 V)

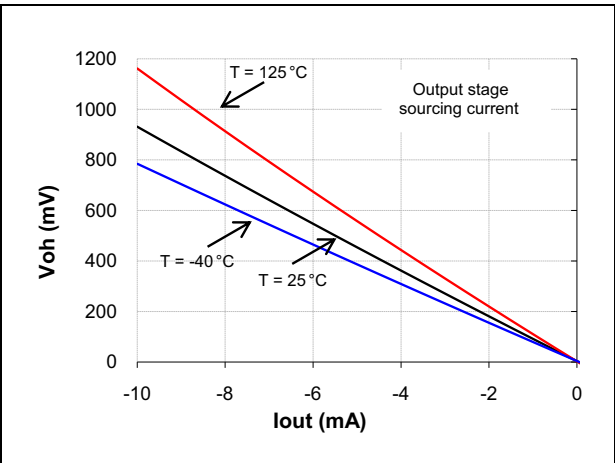

Figure 12. Output stage load regulation

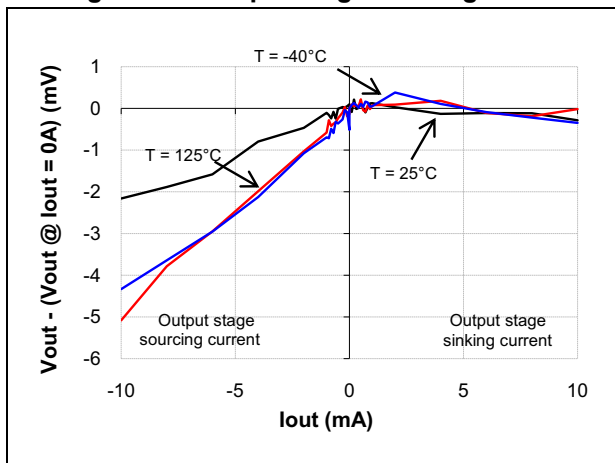

Figure 13. Step response

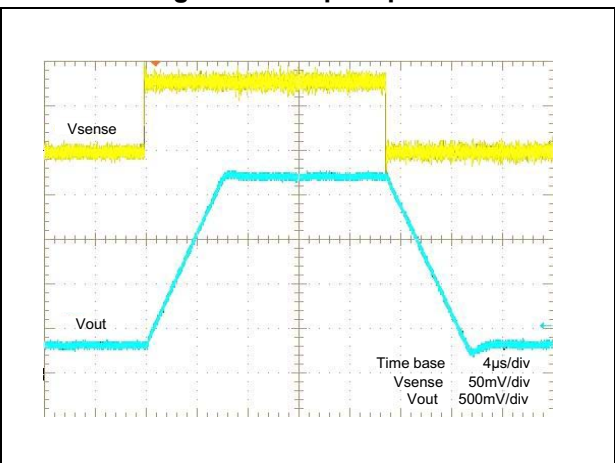

Figure 14. Bode diagram

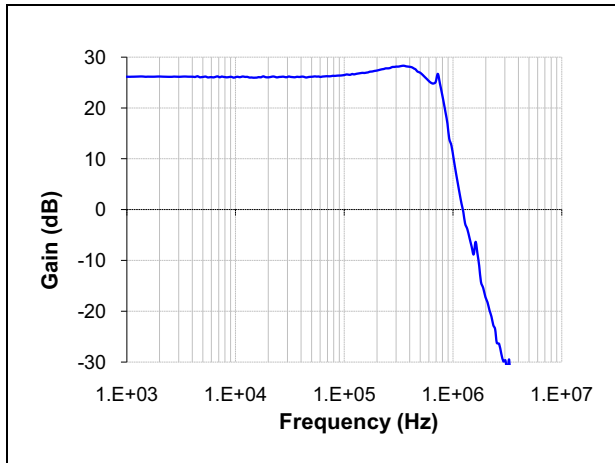

Figure 15. Power supply rejection ratio

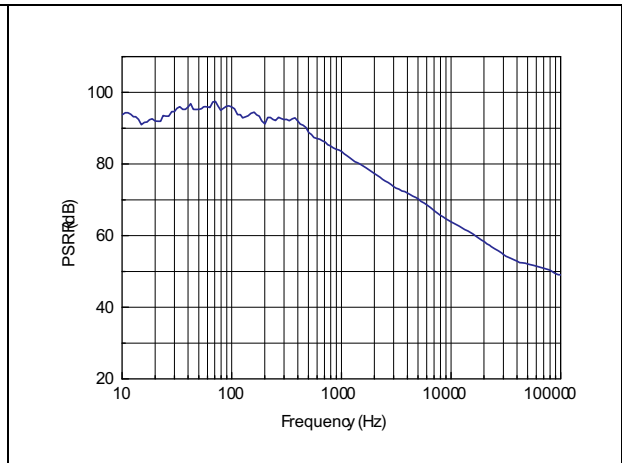
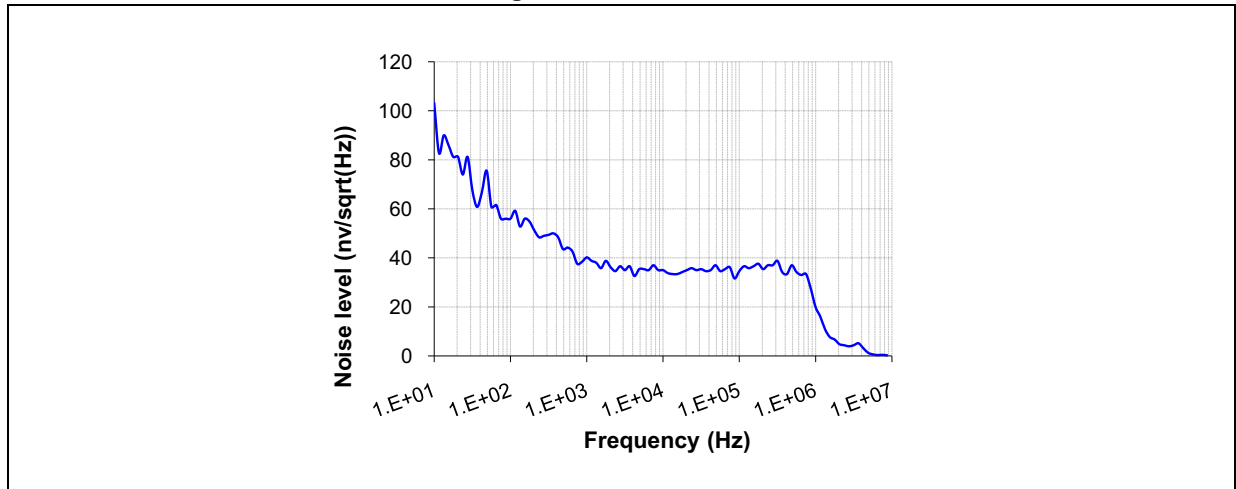

Figure 16. Noise level



5 Parameter definitions

5.1 Common-mode rejection ratio (CMR)

The common-mode rejection ratio (CMR) measures the ability of the current-sensing amplifier to reject any DC voltage applied on both inputs V_p and V_m . The CMR is referred back to the input so that its effect can be compared with the applied differential signal. The CMR is defined by the formula:

$$\text{CMR} = -20 \cdot \log \frac{\Delta V_{\text{out}}}{\Delta V_{\text{icm}} \cdot A_v}$$

5.2 Supply voltage rejection ratio (SVR)

The supply-voltage rejection ratio (SVR) measures the ability of the current-sensing amplifier to reject any variation of the supply voltage V_{CC} . The SVR is referred back to the input so that its effect can be compared with the applied differential signal. The SVR is defined by the formula:

$$\text{SVR} = -20 \cdot \log \frac{\Delta V_{\text{out}}}{\Delta V_{CC} \cdot A_v}$$

5.3 Gain (A_v) and input offset voltage (V_{os})

The input offset voltage is defined as the intersection between the linear regression of the V_{out} vs. V_{sense} curve with the X-axis (see [Figure 17](#)). If V_{out1} is the output voltage with $V_{\text{sense}} = V_{\text{sense1}}$ and V_{out2} is the output voltage with $V_{\text{sense}} = V_{\text{sense2}}$, then V_{os} can be calculated with the following formula.

$$V_{os} = V_{\text{sense1}} - \left(\frac{V_{\text{sense1}} - V_{\text{sense2}}}{V_{\text{out1}} - V_{\text{out2}}} \cdot V_{\text{out1}} \right)$$

Figure 17. V_{out} versus V_{sense} characteristics: detail for low V_{sense} values

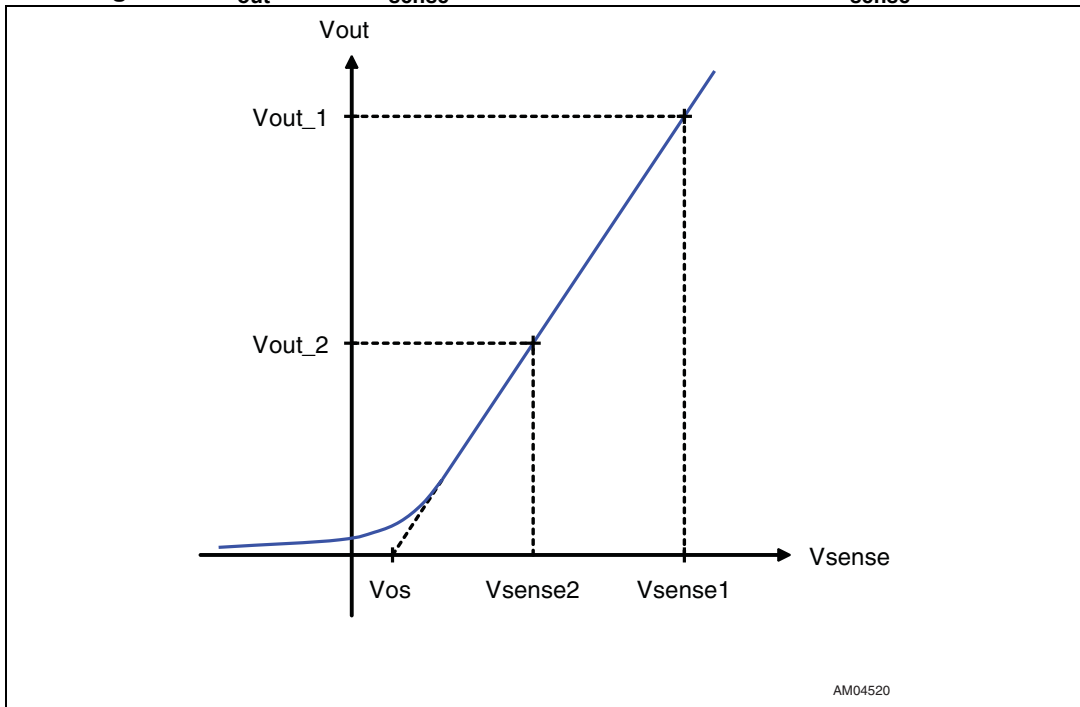

The values of V_{sense1} and V_{sense2} used for the input offset calculations are detailed in [Table 9](#).

Table 9. Test conditions for V_{os} voltage calculation

A_v (V/V)	V_{sense1} (mV)	V_{sense2} (mV)
20	50	5
25	50	5
50	50	5
100	40	5

5.4 Output voltage drift versus temperature

The output voltage drift versus temperature is defined as the maximum variation of V_{out} with respect to its value at 25 °C over the temperature range. It is calculated as follows:

$$\frac{\Delta V_{out}}{\Delta T} = \max \frac{V_{out}(T_{amb}) - V_{out}(25^{\circ}C)}{T_{amb} - 25^{\circ}C}$$

with $T_{min} < T_{amb} < T_{max}$.

Figure 18 provides a graphical definition of the output voltage drift versus temperature. On this chart, V_{out} is always within the area defined by the maximum and minimum variation of V_{out} versus T , and $T = 25^{\circ}C$ is considered to be the reference.

Figure 18. Output voltage drift versus temperature ($A_v = 50$ V/V $V_{sense} = 50$ mV)

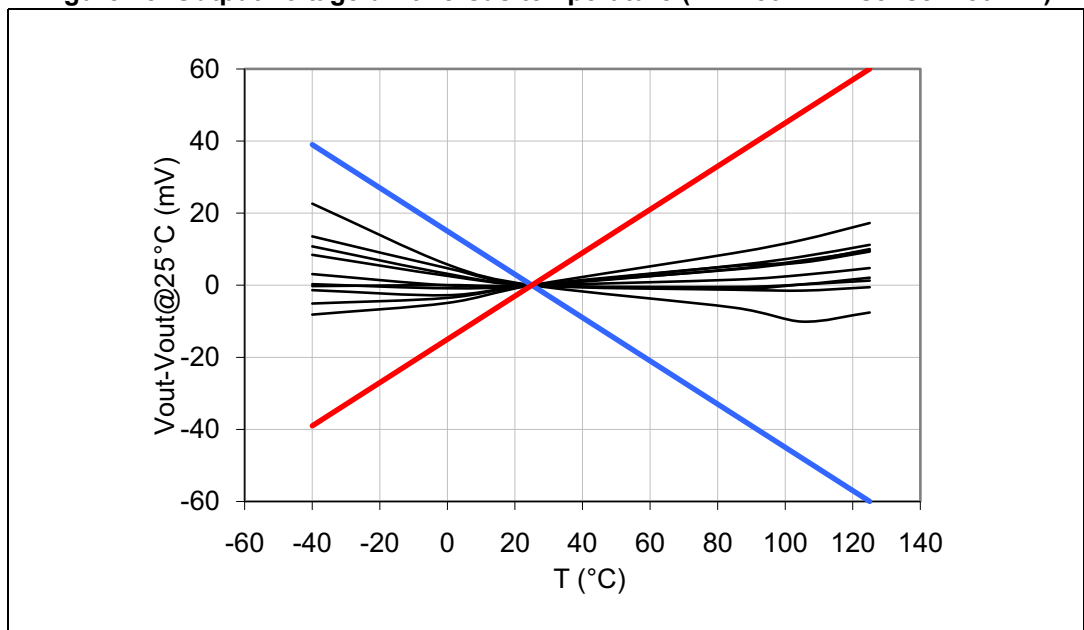

5.5 Input offset drift versus temperature

The input voltage drift versus temperature is defined as the maximum variation of V_{OS} with respect to its value at 25 °C over the temperature range. It is calculated as follows:

$$\frac{\Delta V_{OS}}{\Delta T} = \max \frac{V_{OS}(T_{amb}) - V_{OS}(25^\circ C)}{T_{amb} - 25^\circ C}$$

with $T_{min} < T_{amb} < T_{max}$.

Figure 19 provides a graphical definition of the input offset drift versus temperature. On this chart, V_{OS} is always within the area defined by the maximum and minimum variation of V_{OS} versus T , and $T = 25^\circ C$ is considered to be the reference.

Figure 19. Input offset drift versus temperature ($A_v = 50 V/V$)

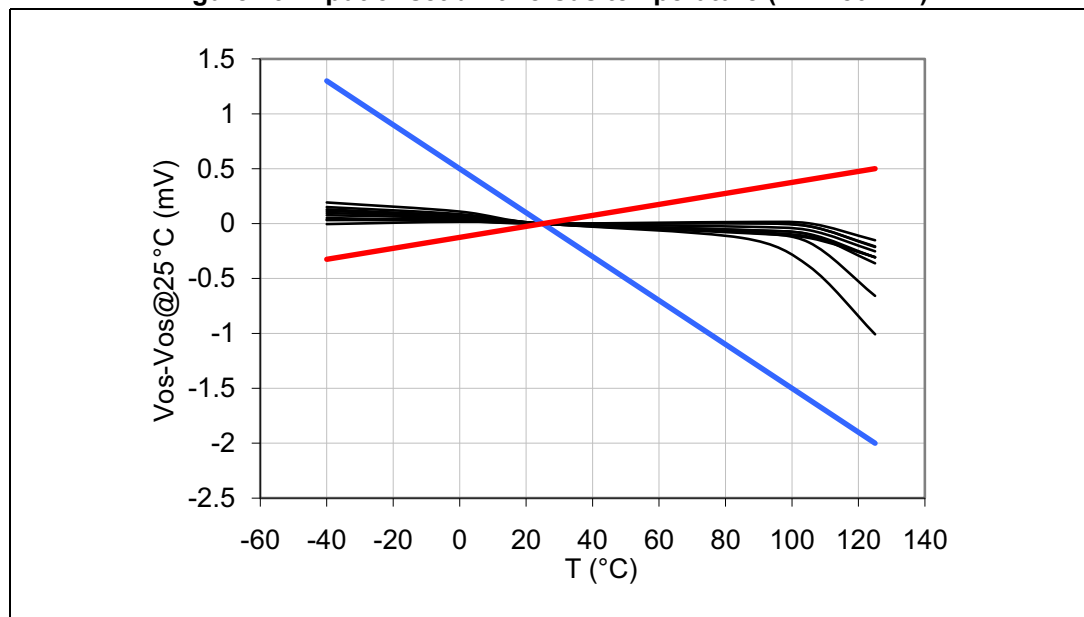

5.6 Output voltage accuracy

The output voltage accuracy is the difference between the actual output voltage and the theoretical output voltage. Ideally, the current sensing output voltage should be equal to the input differential voltage multiplied by the theoretical gain, as in the following formula.

$$V_{out-th} = A_v \cdot V_{sense}$$

The actual value is very slightly different, mainly due to the effects of:

- the input offset voltage V_{OS}
- the non-linearity

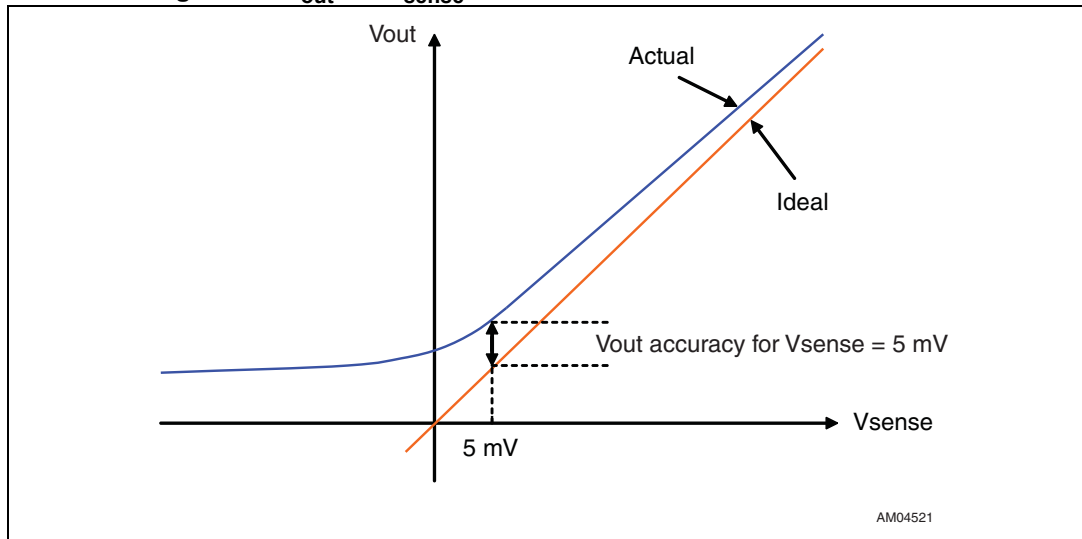
Figure 20. V_{out} vs. V_{sense} theoretical and actual characteristics

The output voltage accuracy, expressed as a percentage, can be calculated with the following formula,

$$\Delta V_{out} = \frac{\text{abs}(V_{out} - (A_v \cdot V_{sense}))}{A_v \cdot V_{sense}}$$

with 20 V/V, 25 V/V, 50 V/V or 100 V/V depending on the configuration of the SEL1 and SEL2 pins.

6 Maximum permissible voltages on pins

The TSC103 can be used in either a single or dual supply configuration. The dual-supply configuration is achieved by disconnecting Vcc- and Gnd, and connecting Vcc- to a negative supply. *Figure 21* illustrates how the absolute maximum voltages on input pins Vp and Vm are referred to the Vcc- potential, while the maximum voltages on the positive supply pin, gain selection pins, and output pins are referred to the Gnd pin. It should also be noted that the maximum voltage between Vcc- and Vcc+ is limited to 15 V.

Figure 21. Maximum voltages on pins

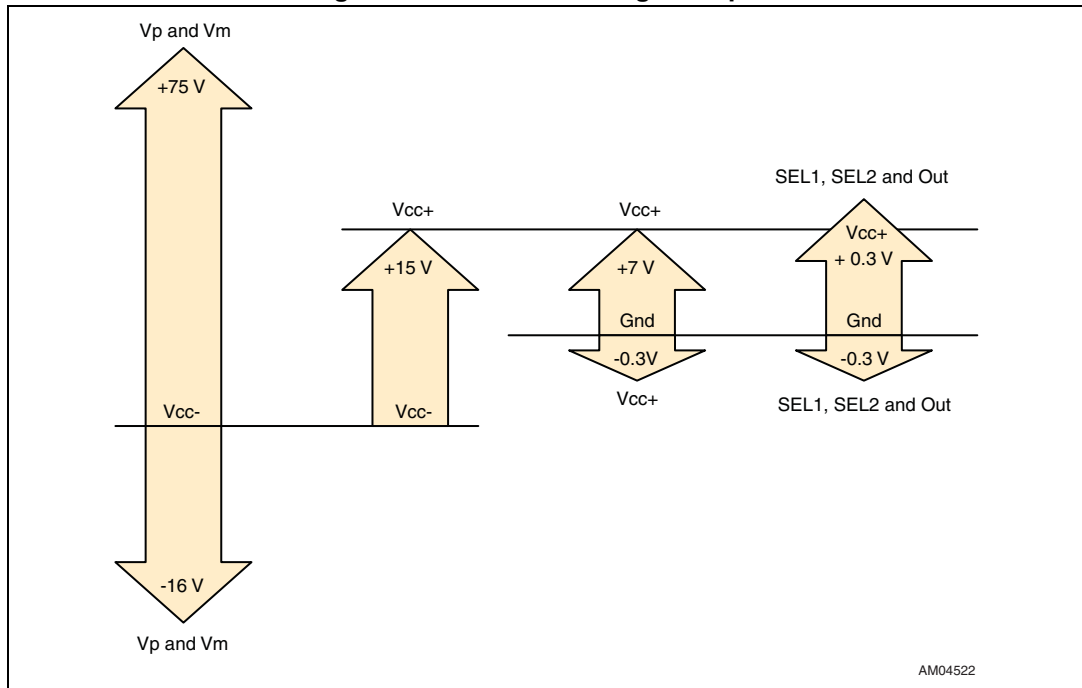

7 Application information

The TSC103 can be used to measure current and to feed back the information to a microcontroller.

Figure 22. Single-supply configuration schematic

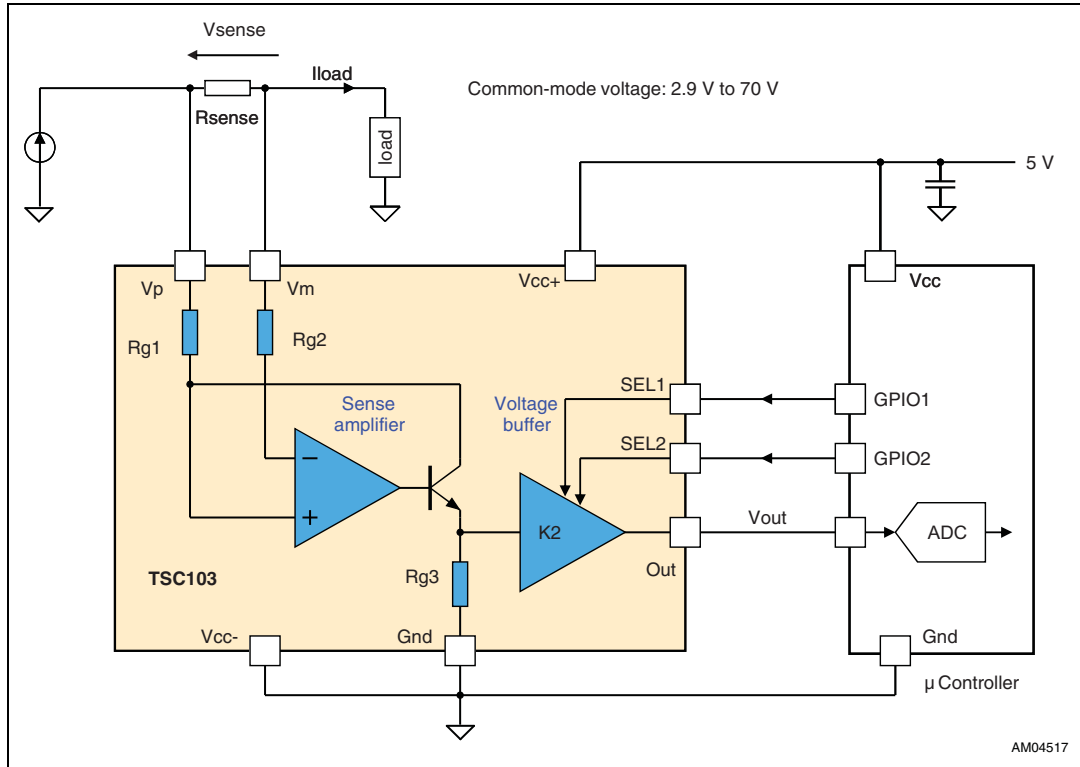

The current from the supply flows to the load through the R_{sense} resistor, causing a voltage drop equal to V_{sense} across R_{sense} . The amplifier's input currents are negligible, therefore its inverting input voltage is equal to V_m . The amplifier's open-loop gain forces its non-inverting input to the same voltage as the inverting input. Consequently, the amplifier adjusts the current flowing through R_{g1} so that the voltage drop across R_{g1} matches V_{sense} exactly.

Therefore, the drop across R_{g1} is:

$$V_{R_{g1}} = V_{sense} = R_{sense} \cdot I_{load}$$

If $I_{R_{g1}}$ is the current flowing through R_{g1} , then $I_{R_{g1}}$ is given by the formula:

$$I_{R_{g1}} = V_{sense} / R_{g1}$$

The $I_{R_{g1}}$ current flows entirely into resistor R_{g3} (the input bias current of the buffer is negligible). Therefore, the voltage drop on the R_{g3} resistor can be calculated as follows.

$$V_{R_{g3}} = R_{g3} \cdot I_{R_{g1}} = (R_{g3} / R_{g1}) \cdot V_{sense} = K1 \cdot V_{sense} \text{ with } K1 = R_{g3} / R_{g1}.$$

The voltage across the R_{g3} resistor is buffered to the Out pin by the voltage buffer, featuring a gain equal to $K2$. Therefore V_{out} can be expressed as:

$$V_{out} = K1 \cdot K2 \cdot V_{sense} = A_v \cdot V_{sense} \text{ with } A_v = K1 \cdot K2$$

or: $V_{out} = A_v \cdot R_{sense} \cdot I_{load}$

The resistor ratio, $K1 = R_{g3}/R_{g1}$, is internally set to 20 V/V, and the voltage buffer gain, K2, can be set to 1, 1.25, 2.5, or 5 depending on the voltage applied on the SEL1 and SEL2 pins. Since they define the full-scale output range of the application, the R_{sense} resistor and the amplification gain A_v are important parameters and must therefore be selected carefully.

8 Package information

In order to meet environmental requirements, ST offers these devices in different grades of ECOPACK[®] packages, depending on their level of environmental compliance. ECOPACK[®] specifications, grade definitions and product status are available at: www.st.com. ECOPACK[®] is an ST trademark.

8.1 TSSOP8 package information

Figure 23. TSSOP8 package mechanical drawing

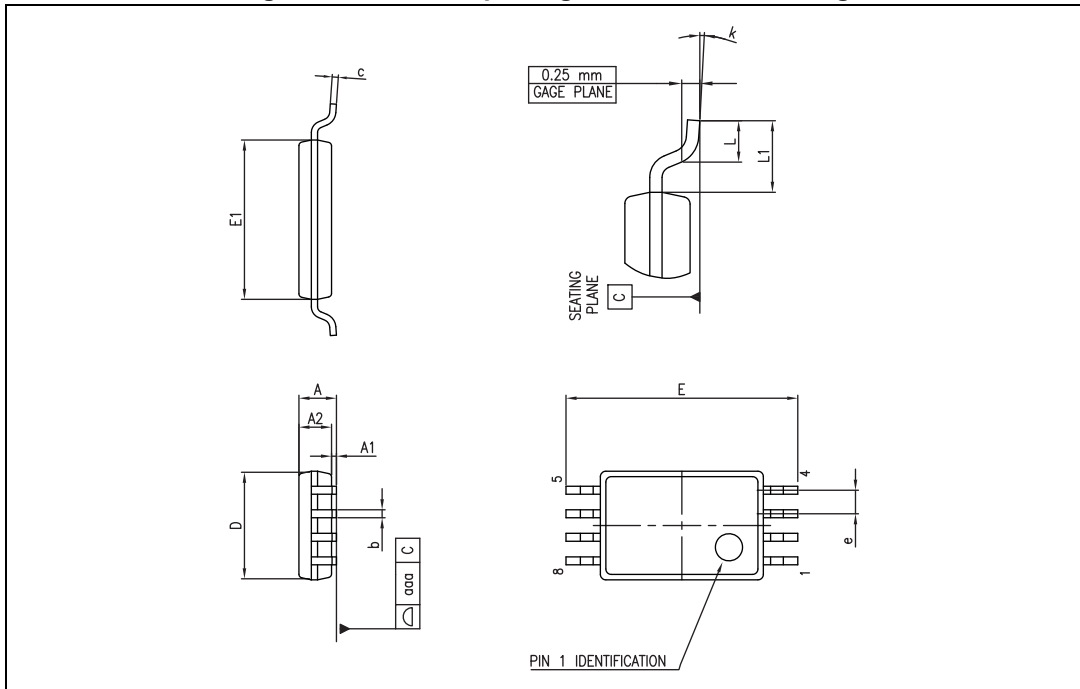

Table 10. TSSOP8 package mechanical data

Ref.	Dimensions					
	Millimeters			Inches		
	Min.	Typ.	Max.	Min.	Typ.	Max.
A			1.20			0.047
A1	0.05		0.15	0.002		0.006
A2	0.80	1.00	1.05	0.031	0.039	0.041
b	0.19		0.30	0.007		0.012
c	0.09		0.20	0.004		0.008
D	2.90	3.00	3.10	0.114	0.118	0.122
E	6.20	6.40	6.60	0.244	0.252	0.260
E1	4.30	4.40	4.50	0.169	0.173	0.177
e		0.65			0.0256	
k	0°		8°	0°		8°
L	0.45	0.60	0.75	0.018	0.024	0.030
L1		1			0.039	
aaa			0.10			0.004

8.2 SO8 package information

Figure 24. SO8 package mechanical drawing

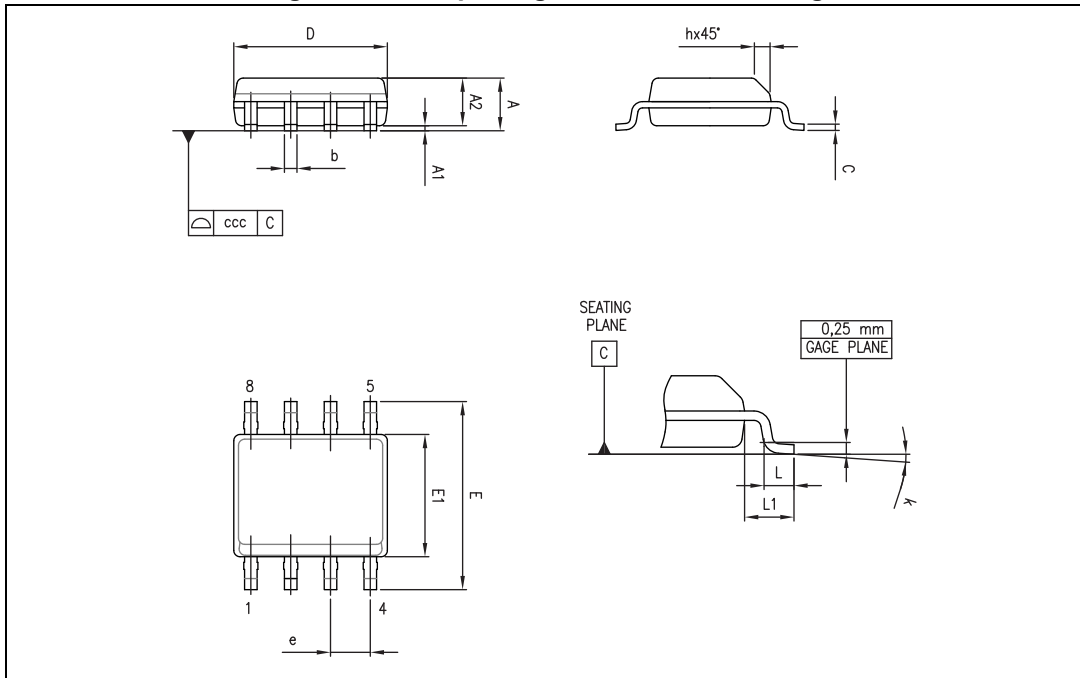

Table 11. SO8 package mechanical data

Ref.	Dimensions					
	Millimeters			Inches		
	Min.	Typ.	Max.	Min.	Typ.	Max.
A			1.75			0.069
A1	0.10		0.25	0.004		0.010
A2	1.25			0.049		
b	0.28		0.48	0.011		0.019
c	0.17		0.23	0.007		0.010
D	4.80	4.90	5.00	0.189	0.193	0.197
E	5.80	6.00	6.20	0.228	0.236	0.244
E1	3.80	3.90	4.00	0.150	0.154	0.157
e		1.27			0.050	
h	0.25		0.50	0.010		0.020
L	0.40		1.27	0.016		0.050
L1		1.04			0.040	
k	0		8°	1°		8°
ccc			0.10			0.004

9 Ordering information

Table 12. Order codes

Part number	Temperature range	Package	Packaging	Marking
TSC103IPT	-40° C, +125 °C	TSSOP8	Tape and reel	103I
TSC103IDT		SO8		TSC103I
TSC103IYPT ⁽¹⁾	-40° C, +125 °C automotive grade	TSSOP8		103Y
TSC103IYDT ⁽¹⁾		SO8		TSC103Y

1. Qualification and characterization according to AEC Q100 and Q003 or equivalent, advanced screening according to AEC Q001 & Q002 or equivalent.

10 Revision history

Table 13. Document revision history

Date	Revision	Changes
04-Jan-2010	1	Initial release.
18-Nov-2011	2	Added Chapter 4: Electrical characteristics curves: current sense amplifier . Changed Figure 4 to Figure 16 . Added automotive grade qualification for SO8 package in Table 12: Order codes .
31-Jan-2014	3	Table 12 : Updated automotive-grade footnotes

Please Read Carefully:

Information in this document is provided solely in connection with ST products. STMicroelectronics NV and its subsidiaries ("ST") reserve the right to make changes, corrections, modifications or improvements, to this document, and the products and services described herein at any time, without notice.

All ST products are sold pursuant to ST's terms and conditions of sale.

Purchasers are solely responsible for the choice, selection and use of the ST products and services described herein, and ST assumes no liability whatsoever relating to the choice, selection or use of the ST products and services described herein.

No license, express or implied, by estoppel or otherwise, to any intellectual property rights is granted under this document. If any part of this document refers to any third party products or services it shall not be deemed a license grant by ST for the use of such third party products or services, or any intellectual property contained therein or considered as a warranty covering the use in any manner whatsoever of such third party products or services or any intellectual property contained therein.

UNLESS OTHERWISE SET FORTH IN ST'S TERMS AND CONDITIONS OF SALE ST DISCLAIMS ANY EXPRESS OR IMPLIED WARRANTY WITH RESPECT TO THE USE AND/OR SALE OF ST PRODUCTS INCLUDING WITHOUT LIMITATION IMPLIED WARRANTIES OF MERCHANTABILITY, FITNESS FOR A PARTICULAR PURPOSE (AND THEIR EQUIVALENTS UNDER THE LAWS OF ANY JURISDICTION), OR INFRINGEMENT OF ANY PATENT, COPYRIGHT OR OTHER INTELLECTUAL PROPERTY RIGHT.

ST PRODUCTS ARE NOT DESIGNED OR AUTHORIZED FOR USE IN: (A) SAFETY CRITICAL APPLICATIONS SUCH AS LIFE SUPPORTING, ACTIVE IMPLANTED DEVICES OR SYSTEMS WITH PRODUCT FUNCTIONAL SAFETY REQUIREMENTS; (B) AERONAUTIC APPLICATIONS; (C) AUTOMOTIVE APPLICATIONS OR ENVIRONMENTS, AND/OR (D) AEROSPACE APPLICATIONS OR ENVIRONMENTS. WHERE ST PRODUCTS ARE NOT DESIGNED FOR SUCH USE, THE PURCHASER SHALL USE PRODUCTS AT PURCHASER'S SOLE RISK, EVEN IF ST HAS BEEN INFORMED IN WRITING OF SUCH USAGE, UNLESS A PRODUCT IS EXPRESSLY DESIGNATED BY ST AS BEING INTENDED FOR "AUTOMOTIVE, AUTOMOTIVE SAFETY OR MEDICAL" INDUSTRY DOMAINS ACCORDING TO ST PRODUCT DESIGN SPECIFICATIONS. PRODUCTS FORMALLY ESCC, QML OR JAN QUALIFIED ARE DEEMED SUITABLE FOR USE IN AEROSPACE BY THE CORRESPONDING GOVERNMENTAL AGENCY.

Resale of ST products with provisions different from the statements and/or technical features set forth in this document shall immediately void any warranty granted by ST for the ST product or service described herein and shall not create or extend in any manner whatsoever, any liability of ST.

ST and the ST logo are trademarks or registered trademarks of ST in various countries.

Information in this document supersedes and replaces all information previously supplied.

The ST logo is a registered trademark of STMicroelectronics. All other names are the property of their respective owners.

© 2014 STMicroelectronics - All rights reserved

STMicroelectronics group of companies

Australia - Belgium - Brazil - Canada - China - Czech Republic - Finland - France - Germany - Hong Kong - India - Israel - Italy - Japan - Malaysia - Malta - Morocco - Philippines - Singapore - Spain - Sweden - Switzerland - United Kingdom - United States of America

www.st.com

