

## Digitally controlled dual PWM with embedded drivers for VR12 processors

Datasheet - production data

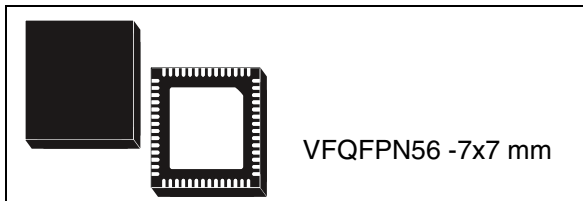

### Features

- VR12 compliant with 25 MHz SVID bus rev. 1.5
- Second generation LTB Technology™
- Very compact dual controller:
  - Up to 4 phases for core section with 2 internal drivers
  - 1 phase for GFX section with internal driver
- Input voltage up to 12 V
- SMBus interface for power management
- SWAP, Jmode, multi-rail only support
- Programmable offset voltage
- Single NTC design for TM, LL and IMON thermal compensation (for each section)
- VFDE for efficiency optimization
- DPM - dynamic phase management
- Dual differential remote sense
- 0.5% output voltage accuracy
- Full-differential current sense across DCR
- AVP - adaptive voltage positioning
- Programmable switching frequency
- Dual current monitor
- Pre-biased output management
- High-current embedded drivers optimized for 7 V operation
- OC, OV, UV and FB disconnection protection
- Dual VR\_READY
- VFQFPN56 7x7 mm package with exposed pad

### Applications

- High-current VRM / VRD for desktop / server / new generation workstation CPUs
- DDR3 DDR4 memory supply for VR12

### Description

The L6718 is a very compact, digitally controlled and cost effective dual controller designed to power Intel® VR12 processors. Dedicated pinstrapping is used to program the main parameters.

The device features from 2 to 4-phase programmable operation for the core section providing 2 embedded drivers. A single-phase with embedded driver and with independent control loop is used for GFX.

The L6718 supports power state transitions featuring VFDE and a programmable DPM, maintaining the best efficiency over all loading conditions without compromising transient response.

Second generation LTB Technology™ allows a minimal cost output filter providing fast load transient response. The controller assures fast and independent protection against load overcurrent, under/overvoltage and feedback disconnections.

The device is available in VFQFPN56, 7x7 mm compact package with exposed pad.

**Table 1. Device summary**

Order code	Package	Packaging
L6718	VFQFPN56 7x7 mm	Tray
L6718TR	VFQFPN56 7x7 mm	Tape and reel

# Contents

<b>1</b>	<b>Typical application circuit and block diagram</b> .....	<b>7</b>
1.1	Application circuit .....	7
1.2	Block diagram .....	10
<b>2</b>	<b>Pin description and connection diagrams</b> .....	<b>11</b>
2.1	Pin description .....	12
2.2	Thermal data .....	19
<b>3</b>	<b>Electrical specifications</b> .....	<b>20</b>
3.1	Absolute maximum ratings .....	20
3.2	Electrical characteristics .....	20
<b>4</b>	<b>VID tables</b> .....	<b>24</b>
<b>5</b>	<b>Device description and operation</b> .....	<b>26</b>
<b>6</b>	<b>Device configuration</b> .....	<b>28</b>
6.1	CPU mode .....	28
6.2	DDR mode .....	28
6.3	SWAP mode .....	29
6.3.1	MRO - multi-phase rail only .....	29
6.4	Jmode .....	30
6.5	Phase number configuration .....	30
6.6	Pinstrapping configuration .....	31
6.6.1	CONFIG0 in CPU mode .....	32
6.6.2	CONFIG0 in DDR mode (STCOMP=GND) .....	34
6.6.3	CONFIG1 in CPU mode .....	36
6.6.4	CONFIG1 in DDR mode (STCOMP=GND) .....	37
6.6.5	CONFIG2 .....	38
6.6.6	CONFIG3 .....	40
<b>7</b>	<b>L6718 power manager</b> .....	<b>42</b>
7.1	SMBus power manager .....	42

7.1.1	SMBus sequence	43
7.2	SMBus tables	43
7.3	DPM	47
7.4	VFDE	48
7.5	Power state indicator (PSI)	49
<b>8</b>	<b>Output voltage positioning</b>	<b>50</b>
8.1	Multi-phase section - current reading and current sharing loop	50
8.2	Multi-phase section - defining load-line	51
8.3	Single-phase section - current reading	52
8.4	Single-phase section - defining load-line	52
8.5	Dynamic VID transition support	53
8.6	DVID optimization: REF/SREF	53
<b>9</b>	<b>Output voltage monitoring and protection</b>	<b>55</b>
9.1	Overvoltage	55
9.2	Overcurrent	56
9.2.1	Multi-phase section	56
9.2.2	Overcurrent and power states	57
9.2.3	Single-phase section	58
<b>10</b>	<b>Single NTC thermal monitor and compensation</b>	<b>59</b>
10.1	Thermal monitor and VR_HOT	59
10.2	Thermal compensation	60
10.3	TM and TCOMP design	60
<b>11</b>	<b>Main oscillator</b>	<b>61</b>
<b>12</b>	<b>System control loop compensation</b>	<b>62</b>
12.1	Compensation network guidelines	63
12.2	LTB technology	64
<b>13</b>	<b>Power dissipation and application details</b>	<b>65</b>
13.1	High-current embedded drivers	65
13.2	Boot diode and capacitor design	65

---

13.3	Device power dissipation .....	65
<b>14</b>	<b>Layout guidelines .....</b>	<b>67</b>
14.1	Power components and connections .....	67
14.2	Small signal components and connections .....	67
<b>15</b>	<b>Package mechanical data .....</b>	<b>68</b>
<b>16</b>	<b>Revision history .....</b>	<b>70</b>

## List of tables

Table 1.	Device summary . . . . .	1
Table 2.	Pin description . . . . .	12
Table 3.	Thermal data . . . . .	19
Table 4.	Absolute maximum ratings . . . . .	20
Table 5.	Electrical characteristics . . . . .	20
Table 6.	VID table, both sections, commanded through serial bus . . . . .	24
Table 7.	Phase number programming . . . . .	31
Table 8.	CONFIG0/PSI0 pinstrapping in CPU MODE . . . . .	33
Table 9.	CONFIG0/PSI0 pinstrapping in DDR MODE . . . . .	35
Table 10.	CONFIG1/PSI1 pinstrapping in CPU MODE . . . . .	36
Table 11.	CONFIG1/PSI1 pinstrapping in DDR MODE . . . . .	37
Table 12.	CONFIG2/SDA pinstrapping . . . . .	39
Table 13.	CONFIG3/SCL pinstrapping . . . . .	40
Table 14.	SMBus addressing . . . . .	43
Table 15.	SMBus interface commands . . . . .	44
Table 16.	SMBus VID . . . . .	45
Table 17.	Power status . . . . .	49
Table 18.	L6718 protection at a glance . . . . .	55
Table 19.	Multi-phase section OC scaling and power states . . . . .	58
Table 20.	VFQFPN56 7x7 mm mechanical data . . . . .	68
Table 21.	Document revision history . . . . .	70

## List of figures

Figure 1.	Typical 4-phase application circuit . . . . .	7
Figure 2.	Typical 3-phase application circuit . . . . .	8
Figure 3.	Typical 2-phase application circuit . . . . .	9
Figure 4.	Block diagram . . . . .	10
Figure 5.	Pin connection (top view) . . . . .	11
Figure 6.	Device initialization . . . . .	27
Figure 7.	SWAP mode . . . . .	29
Figure 8.	SMBus communication format . . . . .	43
Figure 9.	Output current vs. switching frequency in PSK mode. . . . .	48
Figure 10.	Voltage positioning . . . . .	50
Figure 11.	Current reading . . . . .	51
Figure 12.	DVID optimization circuit. . . . .	54
Figure 13.	Thermal monitor connections . . . . .	59
Figure 14.	ROSC [KOhm] vs. switching frequency [kHz] per phase . . . . .	61
Figure 15.	Equivalent control loop . . . . .	62
Figure 16.	Control loop Bode diagram and fine tuning. . . . .	63
Figure 17.	VFQFPN56 7x7 mm package dimensions . . . . .	69

# 1 Typical application circuit and block diagram

## 1.1 Application circuit

Figure 1. Typical 4-phase application circuit

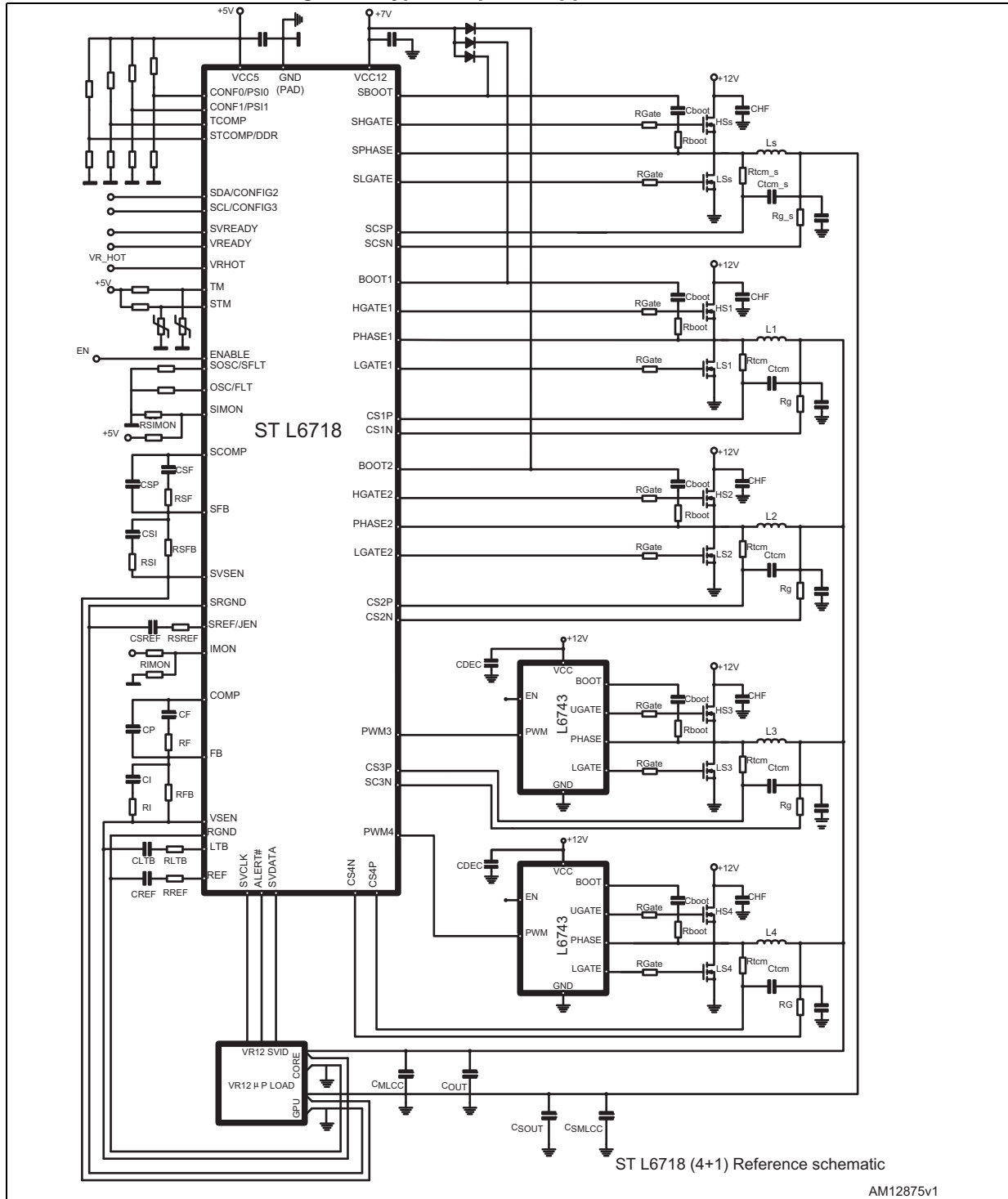

Figure 2. Typical 3-phase application circuit

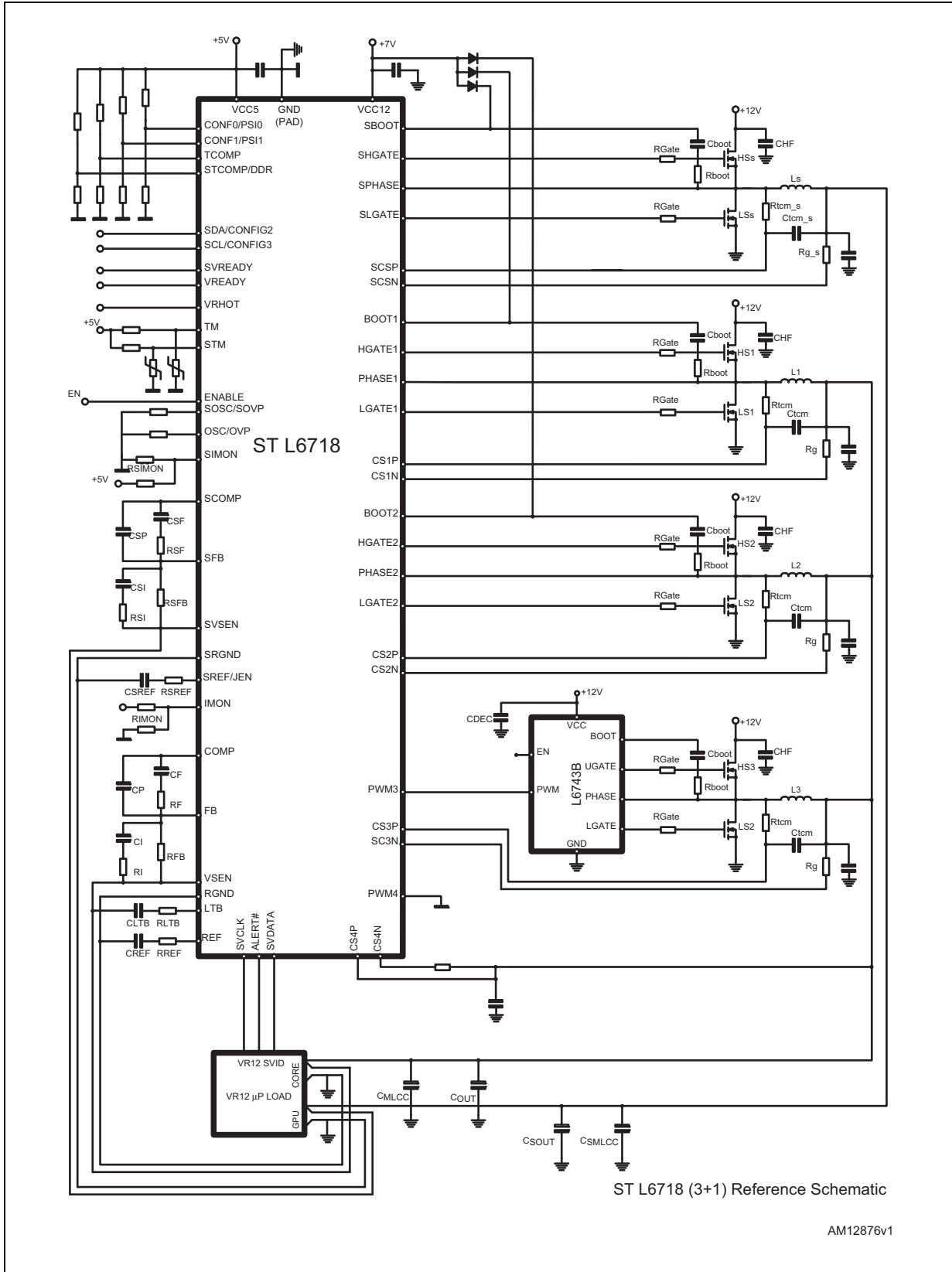
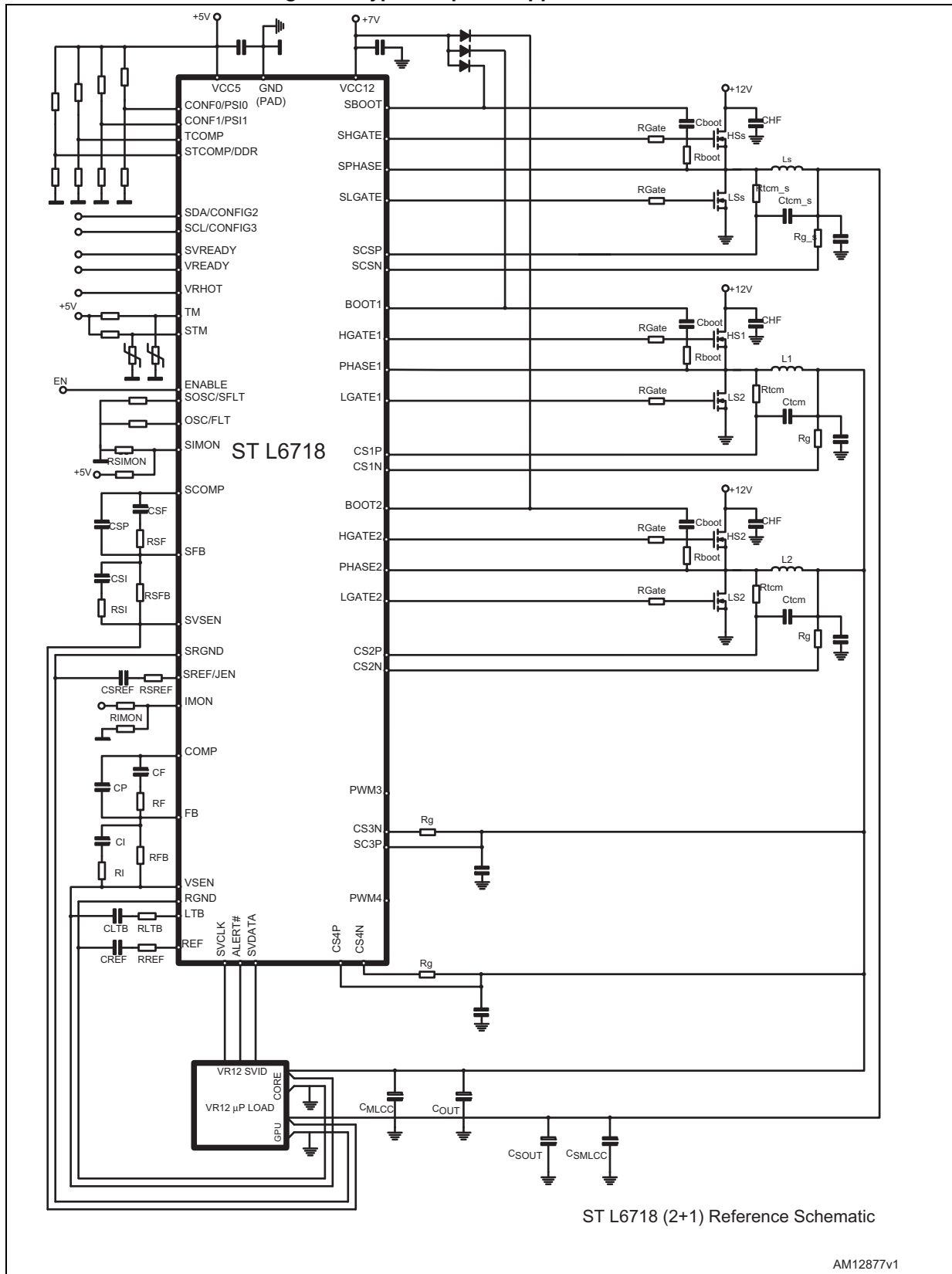

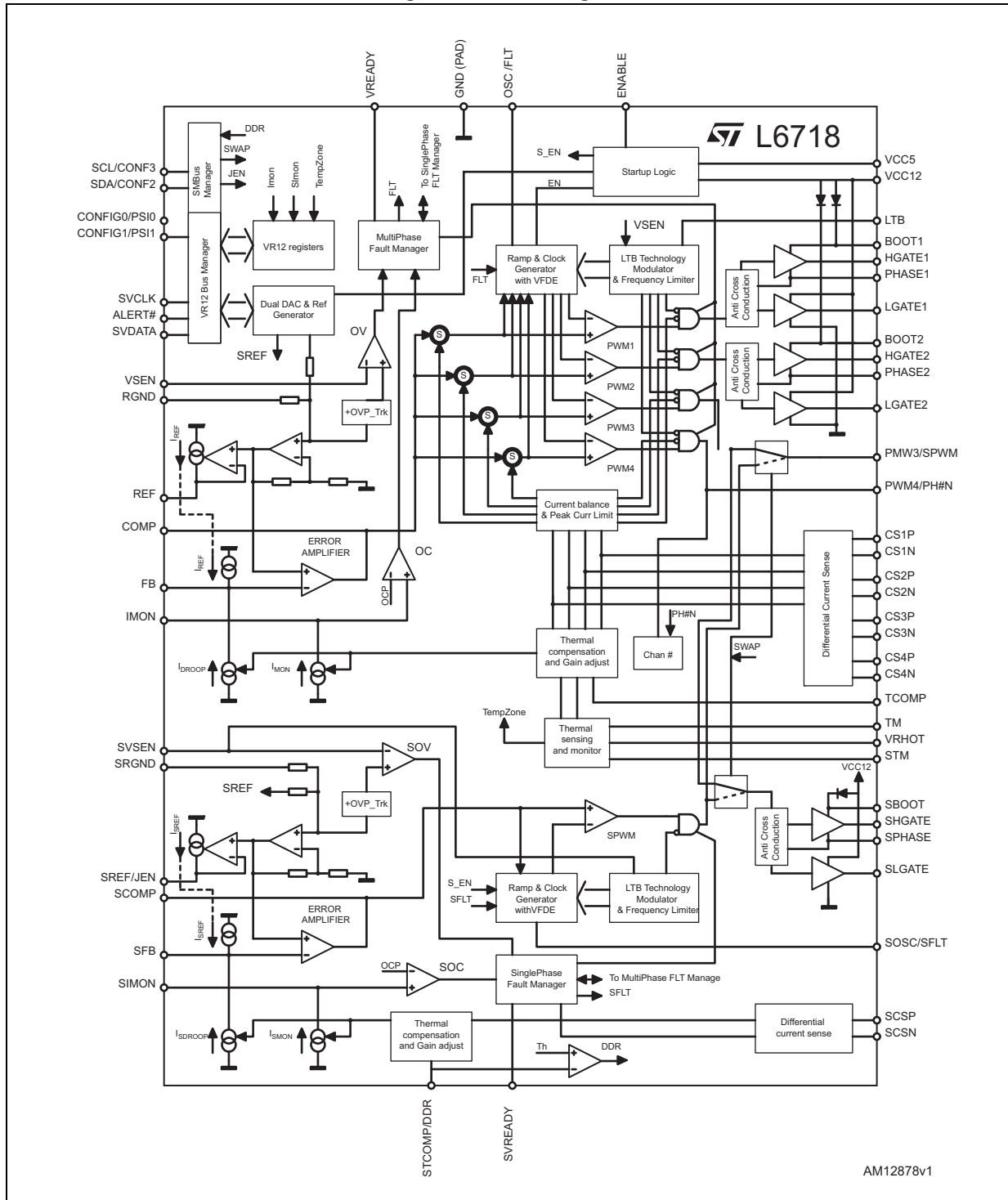

Figure 3. Typical 2-phase application circuit



## 1.2 Block diagram

Figure 4. Block diagram



## 2 Pin description and connection diagrams

Figure 5. Pin connection (top view)

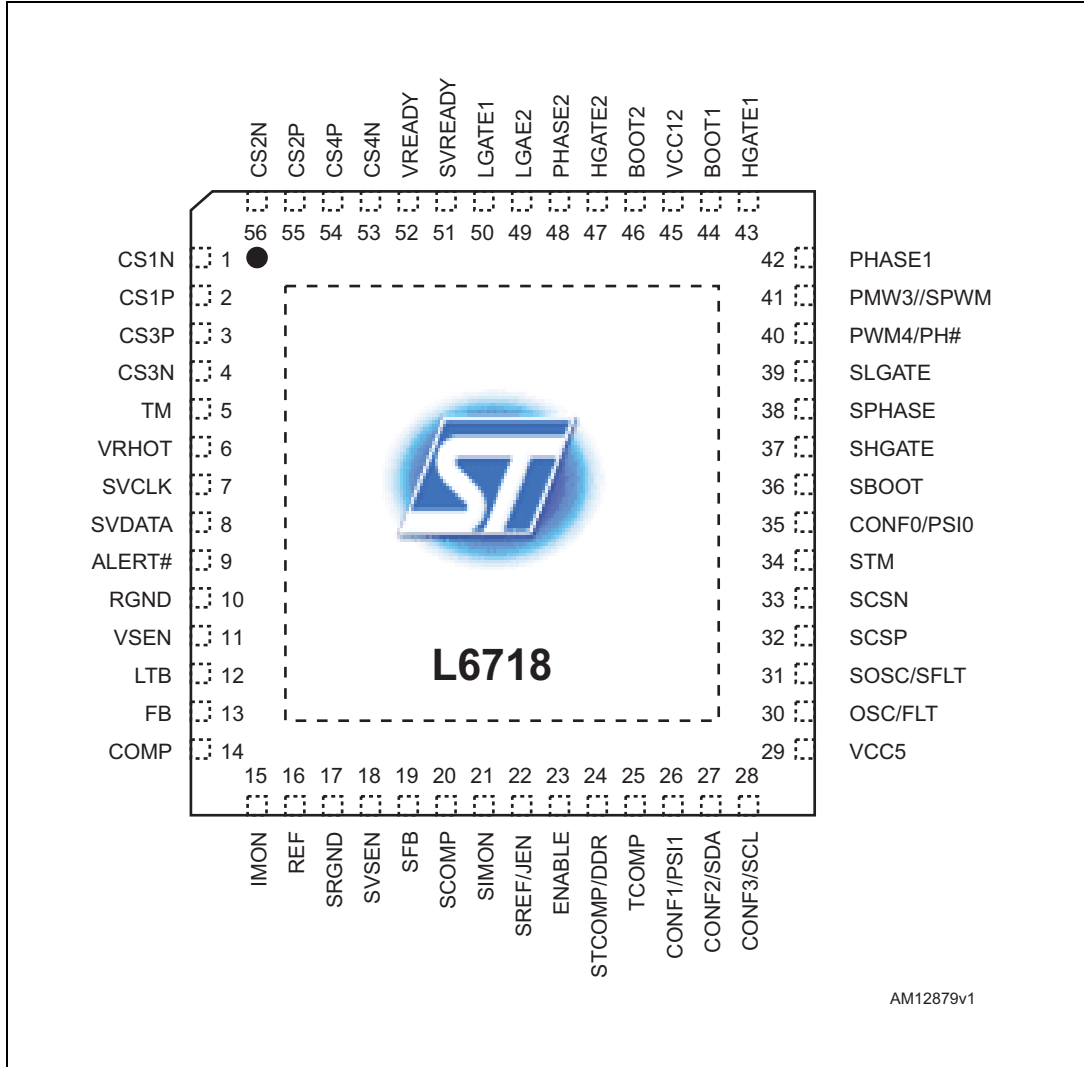

## 2.1 Pin description

**Table 2. Pin description**

Pin#	Name	Function	
1	CS1N	MULTI-RAIL SECTION	Channel 1 current sense negative input. Connect through an $R_G$ resistor to the output-side of channel 1 inductor. Filter the output-side of $R_G$ with 100 nF (typ.) to GND. This pin is compared with VSEN for the feedback disconnection. See <a href="#">Section 14</a> for proper layout of this connection.
2	CS1P		Channel 1 current sense positive input. Connect through an R-C filter to the phase-side of channel 1 inductor. See <a href="#">Section 14</a> for proper layout of this connection.
3	CS3P		Channel 3 current sense positive input. Connect through an R-C filter to the phase-side of channel 3 inductor. Short to $V_{OUT}$ when not using channel 3. See <a href="#">Section 14</a> for proper layout of this connection.
4	CS3N		Channel 3 current sense negative input. Connect through an $R_G$ resistor to the output-side of channel 3 inductor. Filter the output-side of $R_G$ with 100 nF (typ.) to GND. Connect to $V_{OUT}$ through an $R_G$ resistor when not using channel 3. See <a href="#">Section 14</a> for proper layout of this connection.
5	TM		Thermal monitor sensor. Connect with proper network embedding NTC to the multi-phase rail power section. The IC senses the power section temperature and uses the information to define the VRHOT signal and temperature zone register. By programming proper TCOMP gain, the IC also implements load-line thermal compensation for the multi-phase rail section. See <a href="#">Section 10</a> for details.
6	VRHOT		Voltage regulator HOT. Open drain output, set free by controller when the temperature sensed through the TM pin exceeds TMAX (active low). See <a href="#">Section 10.1</a> for details.
7	SVCLK	SVID BUS	Serial clock
8	SVDATA		Serial data
9	ALERT#		Alert

Table 2. Pin description (continued)

Pin#	Name	Function	
10	RGND	MULTI-RAIL SECTION	Remote ground sense pin. Connect to the negative side of the load to perform remote sense. See <a href="#">Section 14</a> for proper layout of this connection.
11	VSEN		Output voltage monitor pin. Manages OVP/UVLP protection and feedback disconnection. Connect to the positive side of the load to perform remote sense. A fixed 50 uA current is sourced from this pin. See <a href="#">Section 14</a> for proper layout of this connection.
12	LTB		Load transient boost technology input pin. Internally fixed at 1.67 V, connecting $R_{LTB} - C_{LTB}$ vs. $V_{OUT}$ allows the load transient boost technology to be enabled, as soon as the device detects a transient load it turns on all the phases at the same time. Short to SGND to disable the function. See <a href="#">Section 12.2</a> for details.
13	FB		Error amplifier inverting input. Connect with an $R_{FB}$ to VSEN and $(R_F - C_F) // C_P$ to COMP. A current proportional to the load current is sourced from this pin in order to implement the droop effect. See <a href="#">Section 8.2</a> for details.
14	COMP		Error amplifier output. Connect with $(R_F - C_F) // C_P$ to FB. The device cannot be disabled by pulling down this pin.
15	IMON		Current monitor output. A current proportional to the multi-phase rail output current is sourced from this pin. Connect through a resistor $R_{IMON}$ to GND to show a voltage proportional to the current load. Based on pin voltage level, DPM and overcurrent protection can be triggered. Filtering through $C_{IMON}$ to GND allows control of the delay. See <a href="#">Section 9.2</a> for $R_{IMON}$ definition.
16	REF		The reference used for the regulation of the multi-phase rail section is available on this pin with -100 mV + offset. Connect through an $R_{REF} - C_{REF}$ to RGND to optimize DVID transitions. See <a href="#">Section 8.6</a> for details.

**Table 2. Pin description (continued)**

Pin#	Name	Function	
17	SRGND	SINGLE-RAIL SECTION	<p>Single-phase rail remote ground sense. Connect to the negative side of the single-phase rail load to perform remote sense. See <a href="#">Section 14</a> for proper layout of this connection.</p>
18	SVSEN		<p>Single-rail output voltage monitor. Manages OVP/UVP protection and feedback disconnection. Connect to the positive side of the load to perform remote sense. It is also the sense for the single-phase rail LTB. Connect to the positive side of the single-phase rail load to perform remote sense. See <a href="#">Section 14</a> for proper layout of this connection.</p>
19	SFB		<p>Error amplifier inverting input. Connect with a resistor <math>R_{SFB}</math> to SVSEN and with <math>(R_{SF} - C_{SF}) // C_{SP}</math> to SCOMP. A current proportional to the load current is supplied from this pin in order to implement the droop effect. See <a href="#">Section 8.4</a> for details.</p>
20	SCOMP		<p>Error amplifier output. Connect with an <math>(R_{SF} - C_{SF}) // C_{SP}</math> to SFB. The device cannot be disabled by pulling this pin low.</p>
21	SIMON		<p>Current monitor output. A current proportional to the output current is sourced from this pin. Connect through a resistor <math>R_{SIMON}</math> to local GND. Based on pin voltage, overcurrent protection can be triggered. Filtering through <math>C_{SIMON}</math> to GND allows control of the delay for OC intervention. See <a href="#">Section 9.2</a> for <math>R_{SIMON}</math> definition.</p>
22	SREF/JEN		<p>The reference used for the regulation of the single-rail section is available on this pin with -100 mV + offset. Connect through an <math>R_{SREF} - C_{SREF}</math> to SRGND to optimize DVID transitions. See <a href="#">Section 8.6</a> for details. If Jmode is selected by Config1 pinstrapping, this pin is used as a logic input for the single-phase rail enable. Pulling this pin up above 0.8 V, the single-phase rail turns on.</p>
23	ENABLE		<p>Enable pin. External pull-up is needed on this pin. Forced low to disable the device with all MOSFETs OFF: all protection is disabled except for preliminary overvoltage. Over 0.65 V the device turns up. Cycle this pin to recover latch from protection, filter with 1 nF (typ.) to GND.</p>
24	STCOMP/ DDR	SINGLE-RAIL SECTION	<p>Thermal monitor sensor gain and DDR selected. Connect proper resistor divider between VCC5 and GND to define the gain to apply to the signal sensed by ST to implement thermal compensation for the single-phase rail. See <a href="#">Section 10</a> for details. Short to GND to disable thermal compensation and set the device to DDR mode.</p>

Table 2. Pin description (continued)

Pin#	Name	Function	
25	TCOMP	MULTI-RAIL SECTION	<p>Thermal monitor sensor gain.</p> <p>Connect proper resistor divider between VCC5 and GND to define the gain to apply to the signal sensed by TM to implement thermal compensation for the multi-phase rail.</p> <p>Short to GND to disable the single NTC thermal compensation for multi-phase section. See <a href="#">Section 10</a> for details.</p>
26	CONFIG1/ PSI1	PINSTRAPPING	<p>Connect a resistor divider to GND and VCC5 to define power management configuration. See <a href="#">Section 6.6</a> for details.</p> <p>At the end of the soft-start, this pin is internally pulled up or pulled down to indicate the power status. See <a href="#">Table 17</a> for details.</p>
27	SDA / CONFIG2	SMBus / PINSTRAPPING	<p>If SMBus power management is enabled through Config0 pinstrapping, connect to data signal of SMBus communicator.</p> <p>If SMBus power management is disabled through Config0 pinstrapping, connect a resistor divider to GND and VCC5 to define power management characteristics. See <a href="#">Section 6.6.5</a> for details.</p>
28	SCL / CONFIG3		<p>If SMBus power management is enabled through Config0 pinstrapping, connect to clock signal of SMBus communicator.</p> <p>If SMBus power management is disabled through Config0 pinstrapping, connect a resistor divider to GND and VCC5 to define power management characteristics. See <a href="#">Section 6.6.5</a> for details.</p>
29	VCC5		<p>Main IC power supply.</p> <p>Operative voltage is connected to 5 V filtered with 1 <math>\mu</math>F MLCC to GND.</p>
30	OSC/FLT	MULTI-RAIL SECTION	<p>Oscillator pin for multi-phase rail.</p> <p>Allows the programming of the switching frequency <math>F_{SW}</math> for multi-phase section. The equivalent switching frequency at the load side results in being multiplied by the number of phases active.</p> <p>The pin is internally set to 1.8 V, frequency is programmed according to a resistor connected to GND or VCC with a gain of 10 kHz/<math>\mu</math>A. Free running is set to 200 kHz.</p> <p>The pin is forced high (3.3 V) if a fault is detected on a multi-rail section. To recover from this condition, it is necessary to cycle VCC or enable. See <a href="#">Section 11</a> for details.</p>
31	SOSC / SFLT	SINGLE-RAIL SECTION	<p>Oscillator pin for single-phase.</p> <p>Allows the programming of the switching frequency <math>F_{SW}</math> for the single-phase section.</p> <p>The pin is internally set to 1.8 V, frequency is programmed according to the resistor connected to GND or VCC with a gain of 10 kHz/<math>\mu</math>A. Free running is set to 200 kHz.</p> <p>The pin is forced high (3.3 V) if a fault is detected on a single-phase rail section. To recover from this condition, it is necessary to cycle VCC or enable. See <a href="#">Section 11</a> for details.</p>

Table 2. Pin description (continued)

Pin#	Name	Function	
32	SCSP	SINGLE-RAIL SECTION	Single-phase rail current sense positive input. Connect through an R-C filter to the phase-side of single-phase rail inductor. See <a href="#">Section 14</a> for proper layout of this connection.
33	SCSN		Single-phase rail current sense negative input. Connect through an $R_G$ resistor to the output-side of single-phase rail inductor. Filter the output-side of $R_G$ with 100 nF (typ.) to GND. See <a href="#">Section 14</a> for proper layout of this connection.
34	STM		Thermal monitor sensor. Connect with proper network embedding NTC to the single-phase power section. The IC senses the hot spot temperature and uses the information to define the VRHOT signal and temperature zone register. By programming proper STCOMP gain, the IC also implements load-line thermal compensation for the single-phase section. Short to GND if not used. See <a href="#">Section 10</a> for details.
35	CONFIG0 /PSI0	PINSTRAPPING	Connect a resistor divider to GND and VCC5 to define power management characteristics. See <a href="#">Section 6.6</a> for details. At the end of the soft-start, this pin is internally pulled up or pulled down to indicate the power status. See <a href="#">Table 17</a> for details.
36	SBOOT	SINGLE-RAIL SECTION	Single-phase rail high-side driver supply. Connect through a capacitor (220 nF typ.) and a resistor (2.2 Ohm) to SPHASE and provide a Schottky bootstrap diode. A small resistor in series to the boot diode helps to reduce boot capacitor overcharge.
37	SHGATE		Single-phase rail high-side driver output. It must be connected to the HS MOSFET gate. A small series resistor helps to reduce the device-dissipated power and the negative phase spike.
38	SPHASE		Single-phase rail high-side driver return path. It must be connected to the HS MOSFET source and provides return path for the HS driver.
39	SLGATE		Single-phase rail low-side driver output. It must be connected to the low-side MOSFET gate. A small series resistor helps to reduce device-dissipated power.
40	PWM4 / PH#		Fourth phase PWM output of the multi-phase rail and phase number selection pin. Internally pulled up to 3.3 V, connect to external driver PWM4 when channel 4 is used. The device is able to manage the HiZ by setting the pin floating. Short to GND or leave floating to 3/2 phase operation, see <a href="#">Table 7</a> for details.



Table 2. Pin description (continued)

Pin#	Name	Function	
41	PWM3 / SPWM		<p>Third phase PWM output of multi-phase rail or PWM output for single-phase rail.</p> <p>Connect to external driver PWM input if this channel is used.</p> <p>Internally pull up to 3.3 V, connect to external driver PWM3 when channel 3 is used (see <a href="#">Table 7</a> for details). The device is able to manage HiZ status by setting the pin floating.</p> <p>If SWAP mode is selected by pinstrapping Config0, it must be connected to single-phase external driver SPWM, see <a href="#">Section 6.3</a> for details.</p>
42	PHASE1	MULTI-RAIL SECTION	<p>Channel 1 HS driver return path.</p> <p>It must be connected to the HS1 MOSFET source and provides return path for the HS driver of channel 1.</p>
43	HGATE1		<p>Channel 1 HS driver output.</p> <p>It must be connected to the HS1 MOSFET gate. A small series resistor helps to reduce the device-dissipated power and the negative phase spike.</p>
44	BOOT1		<p>Channel 1 HS driver supply.</p> <p>Connect through a capacitor (220 nF typ.) and a resistor (2.2 Ohm typ.) to PHASE1 and provide a Schottky bootstrap diode. A small resistor in series to the boot diode helps to reduce boot capacitor overcharge.</p>
45	VCC12		<p>7 V supply.</p> <p>It is the low-side driver supply. It must be connected to the 7 V bus and filtered with 2 x 1 µf MLCC caps vs. GND.</p>
46	BOOT2	MULTI-RAIL SECTION	<p>Channel 2 high-side driver supply.</p> <p>Connect through a capacitor (220 nF typ.) and a resistor (2.2 Ohm typ.) to PHASE2 and provide a Schottky bootstrap diode. A small resistor in series to the boot diode helps to reduce boot capacitor overcharge.</p>
47	HGATE2		<p>Channel 2 high-side driver output.</p> <p>It must be connected to the HS2 MOSFET gate. A small series resistor helps to reduce the device-dissipated power and the negative phase spike</p>
48	PHASE2		<p>Channel 2 HS driver return path.</p> <p>It must be connected to the HS2 MOSFET source and provides a return path for the HS driver of channel 2.</p>
49	LGATE2		<p>Channel 2 low-side driver output.</p> <p>It must be connected to the LS2 MOSFET gate. A small series resistor helps to reduce device-dissipated power.</p>
50	LGATE1		<p>Channel 1 low-side driver output.</p> <p>It must be connected to the LS1 MOSFET gate. A small series resistor helps to reduce device-dissipated power.</p>
51	SVREADY		<p>Single-phase rail VREADY</p> <p>Open drain output set free after SS has finished and pulled low when triggering any protection on the single-phase rail. Pull up to a voltage lower than 3.3 V (typ.), if not used it can be left floating.</p>

**Table 2. Pin description (continued)**

Pin#	Name	Function	
52	VREADY		Multi-phase rail VREADY Open drain output set free after SS has finished and pulled low when triggering any protection on multi-phase rail. Pull up to a voltage lower than 3.3 V (typ.), if not used it can be left floating
53	CS4N	MULTI-RAIL SECTION	Channel 4 current sense negative input. Connect through an R <sub>G</sub> resistor to the output-side of channel 4 inductor. Filter the output-side of R <sub>G</sub> with 100 nF (typ.) to GND. Connect to V <sub>OUT</sub> through an R <sub>G</sub> resistor when not using channel 4. See <a href="#">Section 14</a> for proper layout of this connection.
54	CS4P		Channel 4 current sense positive input. Connect through an R-C filter to the phase-side of channel 3 inductor. Short to V <sub>OUT</sub> when not using channel 4. See <a href="#">Section 14</a> for proper layout of this connection.
55	CS2P		Channel 2 current sense positive input. Connect through an R-C filter to the phase-side of channel 2 inductor. See <a href="#">Section 14</a> for proper layout of this connection.
56	CS2N		Channel 2 current sense negative input. Connect through an R <sub>G</sub> resistor to the output-side of channel 2 inductor. Filter the output-side of R <sub>G</sub> with 100 nF (typ.) to GND. See <a href="#">Section 14</a> for proper layout of this connection.
PAD	GND		GND connection. Exposed pad connects also the silicon substrate. It makes a good thermal contact with the PCB to dissipate the internal power. All internal references and logic are referenced to this pin. Connect to power GND plane using 5.3 x 5.3 mm square area on the PCB and with 9 vias (uniformly distributed) to improve electrical and thermal conductivity.

## 2.2 Thermal data

**Table 3. Thermal data**

Symbol	Parameter	Value	Unit
$R_{th(JA)}$	Thermal resistance junction-to-ambient (device soldered on 2s2p PC board)	27	°C/W
$T_{MAX}$	Maximum junction temperature	150	°C
$T_{STG}$	Storage temperature range	-40 to 150	°C
$T_J$	Junction temperature range	-25 to 125	°C
$P_{tot}$	Maximum power dissipation at $T_{amb} = 25\text{ °C}$	2.5	W

### 3 Electrical specifications

#### 3.1 Absolute maximum ratings

Table 4. Absolute maximum ratings

Symbol	Parameter	Value	Unit
VCC12	To GND	-0.3 to 7.5	V
V <sub>BOOTX</sub> -V <sub>PHASEx</sub>		-0.3 to VCC12 + 0.3	V
	Positive peak voltage t<400 ns	15	V
V <sub>UGATEx</sub> -V <sub>PHASEx</sub>		-0.3 to VCC12 + 0.3	V
LGATEx to GND		-0.3 to VCC12 + 0.3	V
V <sub>PHASEx</sub>	Negative peak voltage to GND t< 400 ns. BOOT>3.5 V	-8	V
	Positive peak voltage to GND t< 200 ns	35	V
VCC5, STM, TM, PWM3, PWM4, SIMAX,IMAX, CONFIGX,	To GND	-0.3 to 7	V
All other pins	To GND	-0.3 to 3.6	V
Maximum withstanding voltage range test condition: JEDEC/JS001- "human body model" acceptance criteria: "normal performance"	BOOTx	± 500	V
	Other pins	± 1000	V

#### 3.2 Electrical characteristics

(V<sub>CC</sub> = 5 V ± 5%, T<sub>J</sub> = 0 °C to 70 °C unless otherwise specified).

Table 5. Electrical characteristics

Symbol	Parameter	Test conditions	Min.	Typ.	Max.	Unit
<b>Supply current</b>						
I <sub>CC5</sub>	VCC5 supply current	ENABLE = High		20		mA
		ENABLE = Low		15		mA
I <sub>CC12</sub>	VCC12 supply current	ENABLE = High; Lgate open Phase to GND; BOOT=7 V		12		mA
		ENABLE = Low		1		mA
I <sub>BOOTX</sub>	BOOTX supply current	ENABLE = High; Ugate open Phase to GND; BOOT=7 V		0.9		mA
Power-on						

Table 5. Electrical characteristics (continued)

Symbol	Parameter	Test conditions	Min.	Typ.	Max.	Unit
UVLO <sub>VCC5</sub>	VCC5 turn-on	VCC5 rising			4.1	V
	VCC5 turn-off	VCC5 falling	3			V
UVLO <sub>VCC12</sub>	VCC12 turn-on	VCC12 rising			4.75	V
	VCC12 turn-off	VCC12 falling	4			V
<b>Oscillator, soft-start and enable</b>						
MP F <sub>SW</sub>	Initial oscillator accuracy	OSC = open	180	200	220	kHz
MP F <sub>SW</sub>	Initial oscillator accuracy	OSC = 62 K	429	475	521	kHz
SP F <sub>SW</sub>	Initial oscillator accuracy	OSC = open	180	200	220	kHz
SP F <sub>SW</sub>	Initial oscillator accuracy	OSC = 62 K	450	500	550	kHz
V <sub>OSC</sub>	PWM ramp amplitude			1.5		V
FAULT	Voltage at pin SOSC	After latch	3			V
	Voltage at pin OSC	After latch	3			V
SOFT START	SS time	Vboot > 0, from pinstrapping; multi-phase section	2.5	2.8	3.1	mV/μs
		Vboot > 0, from pinstrapping; single-phase section	2.5	2.8	3.1	mV/μs
ENABLE	Turn-on	V <sub>ENABLE</sub> rising			0.65	V
	Turn-off	V <sub>ENABLE</sub> falling	0.4			V
<b>SVI Serial Bus</b>						
SVCLCK, SVDATA	Input high		0.6			V
	Input low				0.4	V
SVDATA, ALERT#	Voltage low (ACK)	I <sub>SINK</sub> = -5 mA			50	mV
<b>Reference and current reading</b>						
K <sub>VID</sub>	V <sub>OUT</sub> accuracy (MPhase)	I <sub>OUT</sub> =0 A; N=4; R <sub>G</sub> = 810 Ω; R <sub>FB</sub> =2.125 kΩ	-0.5		0.5	%
K <sub>SVID</sub>	V <sub>OUT</sub> accuracy (SPhase)	I <sub>OUT</sub> =0 A R <sub>G</sub> =1.1 kΩ; R <sub>FB</sub> = 6.662 kΩ	-0.5		0.5	%
DROOP	LL accuracy (MPhase) 0 to full load	I <sub>INFOx</sub> =0; N=4; VID>1 V R <sub>G</sub> =810 Ω; R <sub>FB</sub> =2.125 kΩ	-2.5		2	μA
DROOP	LL accuracy (MPhase) 0 to full load	I <sub>INFOx</sub> =20 μA; N=4; VID>1 V R <sub>G</sub> =810 Ω; R <sub>FB</sub> =2.125 kΩ	-3.5		4	μA
SDROOP	LL accuracy (SPhase) 0 to full load	I <sub>SCSN</sub> =0; VID>1 V R <sub>G</sub> =1.1 kΩ; R <sub>FB</sub> =6.662 kΩ	-0.75		0.75	μA
SDROOP	LL accuracy (SPhase) 0 to full load	I <sub>SCSN</sub> =20 μA; VID>1 V R <sub>G</sub> =1.1 kΩ; R <sub>FB</sub> =6.662 kΩ	-1.5		1.5	μA

Table 5. Electrical characteristics (continued)

Symbol	Parameter	Test conditions	Min.	Typ.	Max.	Unit
k <sub>IMON</sub>	IMON accuracy (MPhase)	I <sub>INFOx</sub> =0 μA; N=4; R <sub>G</sub> =810 Ω; R <sub>FB</sub> =2.125 kΩ	-1.5		1.5	μA
		I <sub>INFOx</sub> =20 μA; N=4; R <sub>G</sub> =810 Ω; R <sub>FB</sub> =2.125 kΩ	-2		2	μA
k <sub>SIMON</sub>	SIMON accuracy (SPhase)	I <sub>SCSN</sub> =0 μA; R <sub>G</sub> =1.1 kΩ; R <sub>FB</sub> =6.662 kΩ	-0.75		0.75	μA
		I <sub>SCSN</sub> =20 μA; R <sub>G</sub> =1.1 kΩ; R <sub>FB</sub> =6.662	-1		1	μA
A <sub>0</sub>	EA DC gain			100		dB
SR	Slew rate	COMP, SCOMP to GND = 10 pF		20		V/μs
DVID	Slew rate fast	Multi-phase section	10			mV/μs
	Slew rate slow		2.5			mV/μs
DVID	Slew rate fast	Single-phase section	10			mV/μs
	Slew rate slow		2.5			mV/μs
IMON ADC	GetReg(15h)	V <sub>IMON</sub> = 0.992 V		CC		Hex
	Accuracy		C0		CF	Hex
<b>PWM OUTPUTS</b>						
PWM3 / SPWM	Output high	I = 1 mA		5		V
	Output low	I = -1 mA			0.2	V
I <sub>PWM3</sub> , I <sub>PWM4</sub>	Pull-up current			10		μA
<b>Protection (both sections)</b>						
OVP	Overvoltage protection	VSEN rising; wrt Ref.		+175		mV
		VSEN rising; wrt Ref.		+500		mV
UVP	Undervoltage protection	VSEN falling; wrt Ref; Ref > 500 mV		-500		mV
FBR DISC	FB disconnection	Vcs - rising above VSEN/SVSEN		+700		
FBG DISC	FBG disconnection	EA NI input wrt VID		+500		
VREADY, SVREADY, VRHOT	Voltage low	I = -4 mA			0.4	V
V <sub>OC_TOT</sub>	Overcurrent threshold	V <sub>IMON</sub> , V <sub>SIMON</sub> rising		1.70		V
				1.55		V
I <sub>OC_TH</sub>	Constant current			35		μA
VRHOT	Voltage low	I <sub>SINK</sub> = -5 mA			13	mΩ
<b>Gate drives control</b>						
t <sub>RISE_UGATE</sub>	High-side rise time	BOOTx - PHASEx = 7 V C <sub>UGATE</sub> to GND=3.3 nF		20		ns

Table 5. Electrical characteristics (continued)

Symbol	Parameter	Test conditions	Min.	Typ.	Max.	Unit
$I_{UGATEx}$	High-side source current	BOOTx - PHASEx =7 V		TBD		A
$R_{UGATEx}$	High-side sink resistance	BOOTx - PHASEx =7 V; 100 mA		2.1		$\Omega$
$t_{RISE\_LGATE}$	Low-side rise time	VCC12 =7 V C <sub>LGATE</sub> to GND=5.6 nF		20		ns
$I_{LGATEx}$	Low-side source current	VCC12 = 7 V		TBD		A
$R_{LGATEx}$	Low-side sink resistance	VCC12 = 7 V; 100 mA		2		$\Omega$

## 4 VID tables

Table 6. VID table, both sections, commanded through serial bus

HEX code		VOUT [V]	HEX code		VOUT [V]	HEX code		VOUT [V]	HEX code		VOUT [V]
0	0	0.000	4	0	0.565	8	0	0.885	C	0	1.205
0	1	0.250	4	1	0.570	8	1	0.890	C	1	1.210
0	2	0.255	4	2	0.575	8	2	0.895	C	2	1.215
0	3	0.260	4	3	0.580	8	3	0.900	C	3	1.220
0	4	0.265	4	4	0.585	8	4	0.905	C	4	1.225
0	5	0.270	4	5	0.590	8	5	0.910	C	5	1.230
0	6	0.275	4	6	0.595	8	6	0.915	C	6	1.235
0	7	0.280	4	7	0.600	8	7	0.920	C	7	1.240
0	8	0.285	4	8	0.605	8	8	0.925	C	8	1.245
0	9	0.290	4	9	0.610	8	9	0.930	C	9	1.250
0	A	0.295	4	A	0.615	8	A	0.935	C	A	1.255
0	B	0.300	4	B	0.620	8	B	0.940	C	B	1.260
0	C	0.305	4	C	0.625	8	C	0.945	C	C	1.265
0	D	0.310	4	D	0.630	8	D	0.950	C	D	1.270
0	E	0.315	4	E	0.635	8	E	0.955	C	E	1.275
0	F	0.320	4	F	0.640	8	F	0.960	C	F	1.280
1	0	0.325	5	0	0.645	9	0	0.965	D	0	1.285
1	1	0.330	5	1	0.650	9	1	0.970	D	1	1.290
1	2	0.335	5	2	0.655	9	2	0.975	D	2	1.295
1	3	0.340	5	3	0.660	9	3	0.980	D	3	1.300
1	4	0.345	5	4	0.665	9	4	0.985	D	4	1.305
1	5	0.350	5	5	0.670	9	5	0.990	D	5	1.310
1	6	0.355	5	6	0.675	9	6	0.995	D	6	1.315
1	7	0.360	5	7	0.680	9	7	1.000	D	7	1.320
1	8	0.365	5	8	0.685	9	8	1.005	D	8	1.325
1	9	0.370	5	9	0.700	9	9	1.010	D	9	1.330
1	A	0.375	5	A	0.705	9	A	1.015	D	A	1.335
1	B	0.380	5	B	0.710	9	B	1.020	D	B	1.340
1	C	0.385	5	C	0.715	9	C	1.025	D	C	1.345
1	D	0.390	5	D	0.720	9	D	1.030	D	D	1.350
1	E	0.395	5	E	0.725	9	E	1.035	D	E	1.355



Table 6. VID table, both sections, commanded through serial bus (continued)

HEX code		VOUT [V]	HEX code		VOUT [V]	HEX code		VOUT [V]	HEX code		VOUT [V]
1	F	0.400	5	F	0.730	9	F	1.040	D	F	1.360
2	0	0.405	6	0	0.735	A	0	1.045	E	0	1.365
2	1	0.410	6	1	0.740	A	1	1.050	E	1	1.370
2	2	0.415	6	2	0.745	A	2	1.055	E	2	1.375
2	3	0.420	6	3	0.750	A	3	1.060	E	3	1.380
2	4	0.425	6	4	0.755	A	4	1.065	E	4	1.385
2	5	0.430	6	5	0.760	A	5	1.070	E	5	1.390
2	6	0.435	6	6	0.765	A	6	1.075	E	6	1.395
2	7	0.440	6	7	0.770	A	7	1.080	E	7	1.400
2	8	0.445	6	8	0.775	A	8	1.085	E	8	1.405
2	9	0.450	6	9	0.780	A	9	1.090	E	9	1.410
2	A	0.455	6	A	0.785	A	A	1.095	E	A	1.415
2	B	0.460	6	B	0.790	A	B	1.100	E	B	1.420
2	C	0.465	6	C	0.795	A	C	1.105	E	C	1.425
2	D	0.470	6	D	0.800	A	D	1.110	E	D	1.430
2	E	0.475	6	E	0.805	A	E	1.115	E	E	1.435
2	F	0.480	6	F	0.810	A	F	1.120	E	F	1.440
3	0	0.485	7	0	0.815	B	0	1.125	F	0	1.445
3	1	0.490	7	1	0.820	B	1	1.130	F	1	1.450
3	2	0.495	7	2	0.825	B	2	1.135	F	2	1.455
3	3	0.500	7	3	0.830	B	3	1.140	F	3	1.460
3	4	0.505	7	4	0.835	B	4	1.145	F	4	1.465
3	5	0.510	7	5	0.840	B	5	1.150	F	5	1.470
3	6	0.515	7	6	0.845	B	6	1.155	F	6	1.475
3	7	0.520	7	7	0.850	B	7	1.160	F	7	1.480
3	8	0.525	7	8	0.855	B	8	1.165	F	8	1.485
3	9	0.530	7	9	0.860	B	9	1.170	F	9	1.490
3	A	0.535	7	A	0.865	B	A	1.175	F	A	1.495
3	B	0.540	7	B	0.870	B	B	1.180	F	B	1.500
3	C	0.545	7	C	0.875	B	C	1.185	F	C	1.505
3	D	0.550	7	D	0.880	B	D	1.190	F	D	1.510
3	E	0.555	7	E	0.905	B	E	1.195	F	E	1.515
3	F	0.560	7	F	0.880	B	F	1.200	F	F	1.520

## 5 Device description and operation

The L6718 dual output PWM controller provides an optimized solution for Intel VR12 CPUs and DDR memory. The three embedded high-current drivers guarantee high performance in a very compact motherboard design. Both sections feature a differential voltage sensing and provide complete control logic and protection for high performance stepdown DC-DC voltage regulators. The multi-phase rail is designed for Intel VR12 CORE or DDR section and features from 2 to 4 phases. The single-phase rail is designed for the GPU section or VTT, or as independent DC-DC voltage regulator.

The multi-phase buck converter is the simplest and most cost-effective topology employable in order to satisfy the high-current requirements of the new microprocessors and modern high-current VRMs. It allows distribution of equal load and power between the phases using smaller and cheaper, and more common, external Power MOSFETs and inductors.

The device features 2<sup>nd</sup> generation LTB Technology™: through a load transient detector, it is able to turn on simultaneously all the phases. This allows the minimization of the output voltage deviation and the system cost by providing the fastest response to a load transient.

The device features an additional power management interface compliant with SMBus 2.0 specifications. This feature increases the system application flexibility; the main voltage regulation parameter (such as overclocking) can be modified while the application is running, assuring fast and reliable transition.

The device can be run also as a DDR supply which uses the single-phase for the termination voltage.

The L6718 is designed to run with 2 embedded drivers for the multi-phase rail and one for the single-phase rail. By using the SWAP mode, it is possible to move all 3 embedded drivers for the multi-phase rail while the single-phase rail is controlled by an external PWM. Single-phase rail can also be turned off.

The device supports Jmode; with this feature the single-phase rail becomes an independent rail with an external enable and VREADY.

The L6718 implements current reading across the inductor in fully differential mode. A sense resistor in series to the inductor can also be considered to improve reading precision. The current information read corrects the PWM output in order to equalize the average current carried by each phase of the multi-phase rail section.

The controller supports VR12 specifications featuring a 25-MHz SVI bus and all the required registers. The platform can program the default registers through dedicated pinstrapping.

A complete set of protections is available: overvoltage, undervoltage, overcurrent (per-phase and total) and feedback disconnection guarantees the load to be safe for both rails under all circumstances.

Special power management features like DPM and VFDE modify the phase number, and switching frequency to optimize the efficiency over the load range.

The L6718 is available in VFQFPN56 with 7x7 mm body package.

Figure 6. Device initialization

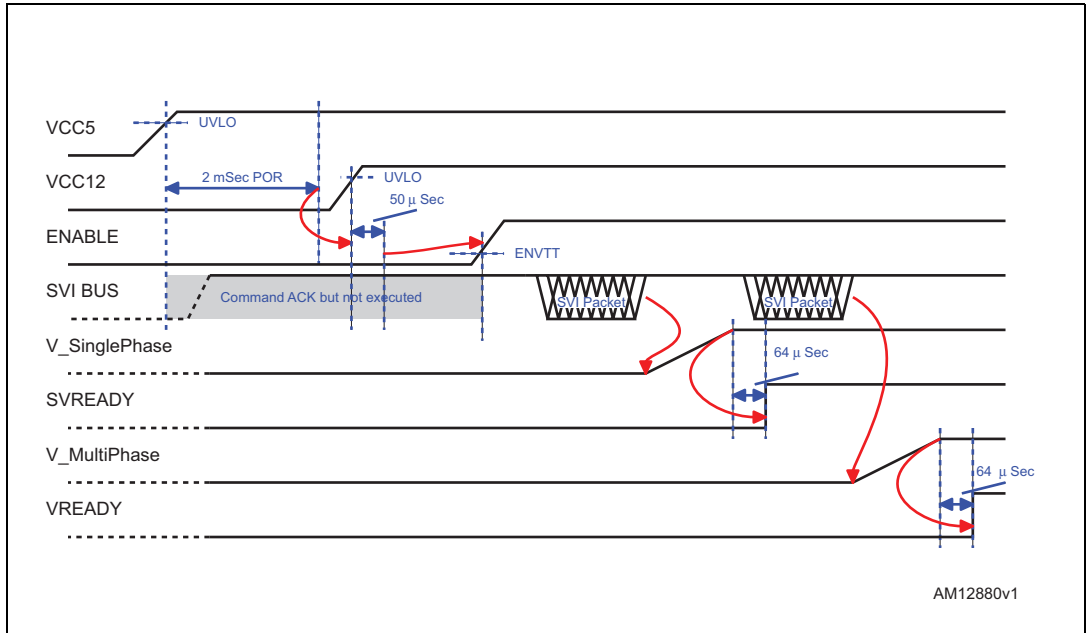

## 6 Device configuration

The device is designed to provide power supply to the Intel VR12 CPUs, DDR memory and also for DC-DC power supply general purposes. It features a universal serial data bus fully compliant with Intel VR12/IMVP7 protocol rev. 1.5. document #456098. The controller can be set to work in 2 main configurations: CPU mode and DDR mode which include also the settings for DC-DC general purposes.

In CPU mode the device is able to manage the multi-phase rail to supply the Intel CPU CORE section while single-phase rail can be used for the graphics section embedded on the VR12 CPUs.

Setting the DDR mode, the device uses the multi-phase rail to provide the DDR memory power supply (or DC-DC for general purposes) and it is possible to select the single-phase rail to supply the VTT termination voltage.

Setting SWAP mode moves all three embedded drivers to run for the multi-phase rail section while an external PWM provides the regulation for the single-phase. In this configuration the single-phase rail can also be disabled, therefore moving the device to run with the multi-phase rail only (MRO mode).

Setting Jmode, the single-phase rail becomes an independent DC-DC converter with enable and Power Good (SVREADY).

The 2 main configurations (CPU mode and DDR mode) can be combined with SWAP mode, MRO mode and Jmode in order to maximize the number of device configurations to fit any motherboard.

### 6.1 CPU mode

The device enters CPU mode by connecting the STCOMP/DDR pin to an external divider. After the soft-start the controller uses the STCOMP pin for thermal monitoring (see [Section 10.3](#)).

In this configuration the device provides the power supply for the VR12 CPU CORE section by using the multi-phase rail while, if Jmode and MRO are disabled, the single-phase rail is used to supply the VR12 CPU GPU section.

The controller use 00h as SVID bus address for the multi-phase rail while the single-phase rail, if used for the GPU section, is addressed by 01h, following the SVID Intel specifications for VR12 CPUs. In MRO mode it is possible to address the CPU with 00h or 01h.

In CPU mode it is possible to set up the Jmode, Swap mode and MRO mode in order to have maximum flexibility for the power supply solution.

### 6.2 DDR mode

DDR mode can be enabled by shorting the STCOMP/DDR pin to GND.

During the startup, the device reads the voltage on the STCOMP/DDR pin and, if it is under 0.3 V, the DDR mode is set up and the device is able to supply DDR memory or the DC-DC converter for general purposes.

The multi-phase rail can be configured to supply DDR2, DDR3 and DDR4 while, if Jmode and MRO mode are disabled, the single-phase rail is set automatically to supply the DDR voltage termination VDDQ/2 (reference is to VSEN/2) and the SIMAX embedded register is fixed at 30 A.

The main characteristics are fixed by pinstrapping (see [Section 6.6](#)) and the single NTC thermal compensation is disabled on the single-phase rail.

In DDR mode it is possible to set up the Jmode, Swap mode and MRO mode in order to have maximum flexibility for the power supply solution.

## 6.3 SWAP mode

SWAP mode can be configured by the CONFIG0 pinstrapping pin (see [Section 6.6.1](#) and [Section 6.6.2](#)).

If SWAP mode is selected, the device swaps the embedded driver of the single-phase rail PWM with the third phase PWM3.

This means that the single-rail becomes the third phase driver for the multi-phase rail section. As a consequence, the single-rail PWM signal is provided on the PWM3/SPWM pin and the single-phase rail runs with an external driver.

Using all three embedded drivers for the multi-phase rail section guarantees a very compact solution for high integrated VRM design while the external driver single-rail section can be the optimal solution VRM single-phase designed far from the controller.

Once SWAP mode is enabled the VFDE on the single-phase rail is disabled and it can not be turned on by the SMBus or pinstrapping.

Figure 7. SWAP mode

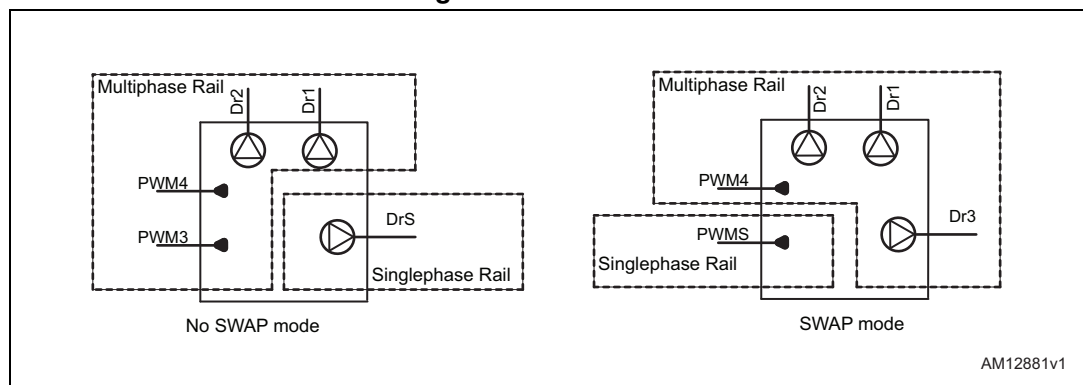

### 6.3.1 MRO - multi-phase rail only

If SWAP mode is set and the PWM3/SPWM pin is left floating, the system is configured with the single-phase rail disabled. This configuration sets the controller to switch with only the multi-phase rail (MRO - multi-phase rail only) ignoring any event on the single-phase rail. The number of switching phase can be enabled by using PWM4 (see [Table 7](#)).

If the device is configured in MRO mode and in CPU mode, it is possible to select the SVID bus addressing between 00h and 01h by the CONFIG0 pin (see [Section 6.6.1](#) and

[Section 6.6.2](#)). This function can be useful in applications where the graphics section needs to be designed with a multi-phase rail.

When setting MRO mode, the single-phase rail is off and Jmode can not be enabled. Jmode bitstrapping is still used to select the multi-phase number (see [Table 7](#)).

## 6.4 Jmode

Jmode is selectable during startup through the CONFIG1 pinstrapping pin (see [Section 6.6.3](#) and [Section 6.6.4](#)).

If Jmode is configured, the controller sets the single-phase rail to switch as a completely independent single-phase rail. As a consequence:

1. Single-phase rail is not addressed by the SVID bus. The device replies with a NACK to any request by the CPU to communicate with the single-phase rail.
2. Single-phase rail becomes the DC-DC controller with an internal reference fixed at 0.75 V, so it is possible to select the output voltage by using a divider.
3. Droop is disabled on the single-phase rail.
4. The SREF/JEN pin is configured as single-phase rail enable. As a consequence, this pin becomes a digital logic input. If it is set HIGH, the device turns on the single-phase rail, otherwise the single rail remains off. An embedded pull-up sets the pin floating to high.
5. The SVREADY is still used as single-phase Power Good.
6. Single-phase rail maximum current embedded register is fixed at 30 A.
7. In CPU mode, using the CONFIG0 pinstrapping, it is possible to set the used multi-phase rail address to 01h (to supply the graphics section).
8. If a fault occurs on the multi-phase rail, the single-phase rail still runs.
9. If the device is set in a debug configuration (see [Section 6.6](#)), the multi-phase can turn on only if Jmode is on, while in operating configuration the multi-phase rail and single-phase rail can be turned on independently.

Jmode is an option for motherboard designs which need the multi-phase rail section to supply the CPU CORE or DDR sections but they also need a single-phase high performance DC-DC converter to supply other rails on the motherboard (such as VCCIO).

Jmode offers an advantage by having a free high performance single-phase buck controller with voltage and current remote differential sensing, LTB, and voltage and current protection. Output voltage can be increased with the use of an external divider or by adding offset with SMBus or pinstrapping.

## 6.5 Phase number configuration

The multi-phase rail can be configured from 2 to 4-phase switching while the single-phase rail can be also set off in MRO only. By using pinstrapping it is also possible to select the number of embedded drivers used for the multi-phase rail (see [Table 7](#)).

During soft-start the device is able to check the status of the PWMx pins and set the multi-phase rail total phase number. Setting SWAP mode the device uses all the embedded drivers for the multi-phase rail section while external PWM is used for the single-phase rail (see [Section 6.3](#) for details). Jmode can change the status of the total phase number only in MRO (see [Section 6.3.1](#) for details).

**Caution:** For the disabled phase(s), the current reading pins need to be properly connected to avoid errors in current-sharing and voltage-positioning: CSxP must be connected to the regulated output voltage while CSxN must be connected to CSxP through the same  $R_G$  resistor used for the active phases.

**Table 7. Phase number programming**

Total solution (multi+single)	Embedded driver assignment (multi+single)	PWM4 / PHSEL	PWM3 / SPWM	SWAP <sup>(1)</sup>	Jmode <sup>(2)</sup>
4 + 1	2 + 1	Driver	Driver	OFF	X <sup>(3)</sup>
4 + 1	3 + 0			ON	
3 + 1	2 + 1	OFF			
3 + 1	3 + 0	ON			
2 + 1	2 + 1	Floating	Floating	OFF	
MRO <sup>(4)</sup> (multi-phase rail only)					
4 + 0	3 + 0	Driver	Floating	ON	X
3 + 0	3 + 0	Floating/GND			ON
2 + 0	2 + 0				OFF

1. SWAP mode can be enabled/disabled through Config0 pinstrapping (see [Section 6.6.1](#) and [Section 6.6.2](#)).
2. Jmode can be enabled/disabled through Config1 pinstrapping (see [Section 6.6.3](#) and [Section 6.6.4](#)).
3. Jmode can be enabled/disabled.
4. In MRO the single-phase is disabled.

## 6.6 Pinstrapping configuration

Pinstrapping is used to select different configuration settings.

The pinstrapping must be connected through a divider to the VCC5 pin and to GND.

During startup, the device reads the voltage level on the pinstrapping pins and selects the right configuration from 32 configurations (5 bitstrappings) for each pinstrapping.

Pinstrapping configuration depends also on:

- Device status (CPU or DDR mode)
- Number of phases configured
- Status of other pinstrappings

### 6.6.1 CONFIG0 in CPU mode

Config0/PSI0 is a multi-functional pin, during startup, it is used as CONFIG0 pinstrapping to select the device configuration.

CONFIG0 select (see [Table 8](#)):

- a) SWAP mode: Set SWAP ON to enter SWAP mode. As a consequence, all 3 embedded drivers run for the multi-phase rail (see [Section 6.3](#)).
- b) SMBus: Set SMBus OFF to disable SMBus function. As a consequence, pins CONFIG2/SDA and CONFIG3/SCL are used as pinstrapping CONFIG2 and CONFIG3 (see [Section 6.6.5](#) and [Section 6.6.6](#)). If SMBus is set ON, pins CONFIG2/SDA and CONFIG3/SCL are set as serial data (SDA) and serial clock (SCL) used for the SMBus communication (see [Section 7.1](#)).
- c) If Jmode is set ON by CONFIG1 pinstrapping (see [Section 6.6.3](#)), it is possible to select the serial VID address of the rail between 00h and 01h. This option can be useful in designs where multi-phase rail is necessary for the graphics section. The boot voltage for the multi-phase rail can be selected from 0.9 V, 1 V and 1,1 V, which are for debug mode, while operating mode is set to 0 V.
- d) If Jmode is set OFF and the single-phase rail is used to supply the graphics (no MRO mode condition), it is possible to set the single-phase rail between 30 A and 35 A while the voltage boot can change between 0 V and 1 V for the multi-phase rail and 0 V, 0,9 V, 1 V and 1,1 V for the single-phase rail. The only operating mode configuration is 0 V for both rails.
- e) If the PMW3/SPMW pin is floating and CONFIG0 is set with SWAP to ON, the device is configured in multi-phase rail only (MRO). In MRO the single-phase rail is OFF so CONFIG0 is set as in point c.



Table 8. CONFIG0/PSI0 pinstrapping in CPU MODE

Pinstrapping <sup>(1)</sup> divider (KOhm)		SWAP mode	SMBus	SVID <sup>(2)</sup> status	Jmode ON <sup>(3)</sup>		Jmode OFF & MRO disable <sup>(4)</sup>			MRO enable <sup>(5)</sup>	
R up	R down				SVID ADD	Multi Vboot	SIMA X	Multi Vboot	Single Vboot	SIMAX / ADD	Multi Vboot
13	36	OFF	OFF	Debug	00h	1 V	30 A	1 V	1 V	Not applicable	
24	27	OFF	OFF	Debug	00h	0.9 V	30 A	0 V	0.9 V		
24	30	OFF	OFF	Debug	00h	1.1 V	30 A	0 V	1.1 V		
27	100	OFF	OFF	Operating	00h	0 V	30 A	0 V	0 V		
16	51	OFF	OFF	Debug	01h	1 V	35 A	1 V	1 V		
16	39	OFF	OFF	Debug	01h	0.9 V	35 A	0 V	0.9 V		
13	18	OFF	OFF	Debug	01h	1.1 V	35 A	0 V	1.1 V		
18	110	OFF	OFF	Operating	01h	0 V	35 A	0 V	0 V		
91	12	OFF	ON	Debug	00h	1 V	30 A	1 V	1 V		
120	51	OFF	ON	Debug	00h	0.9 V	30 A	0 V	0.9 V		
91	15	OFF	ON	Debug	00h	1.1V	30 A	0 V	1.1 V		
120	39	OFF	ON	Operating	00h	0 V	30 A	0 V	0 V		
100	20	OFF	ON	Debug	01h	1 V	35 A	1 V	1 V		
14,7	15	OFF	ON	Debug	01h	0.9 V	35 A	0 V	0.9 V		
39	11	OFF	ON	Debug	01h	1.1 V	35 A	0 V	1.1 V		
43	16	OFF	ON	Operating	01h	0 V	35 A	0 V	0 V		
75	18	ON	OFF	Debug	00h	1 V	30A	1 V	1 V	00h	1 V
68	56	ON	OFF	Debug	00h	0.9 V	30A	0 V	0.9 V	00h	0.9 V
47	43	ON	OFF	Debug	00h	1.1 V	30A	0 V	1.1 V	00h	1.1 V
82	39	ON	OFF	Operating	00h	0 V	30A	0 V	0 V	00h	0 V
36	62	ON	OFF	Debug	01h	1 V	35A	1 V	1 V	01h	1 V
39	75	ON	OFF	Debug	01h	0.9 V	35A	0 V	0.9 V	01h	0.9 V
33	51	ON	OFF	Debug	01h	1.1 V	35A	0 V	1.1 V	01h	1.1 V
18	39	ON	OFF	Operating	01h	0 V	35A	0 V	0 V	01h	0 V
750	10	ON	ON	Debug	00h	1 V	30A	1 V	1 V	00h	1 V
56	30	ON	ON	Debug	00h	0.9 V	30A	0 V	0.9 V	00h	0.9 V
20	12	ON	ON	Debug	00h	1.1 V	30A	0 V	1.1 V	00h	1.1 V
390	16	ON	ON	Operating	00h	0 V	30A	0 V	0 V	00h	0 V
390	27	ON	ON	Debug	01h	1 V	35A	1 V	1 V	01h	1 V
36	24	ON	ON	Debug	01h	0.9 V	35A	0 V	0.9 V	01h	0.9 V

**Table 8. CONFIG0/PSI0 pinstrapping in CPU MODE (continued)**

Pinstrapping <sup>(1)</sup> divider (KOhm)		SWAP mode	SMBus	SVID <sup>(2)</sup> status	Jmode ON <sup>(3)</sup>		Jmode OFF & MRO disable <sup>(4)</sup>			MRO enable <sup>(5)</sup>	
R up	R down				SVID ADD	Multi Vboot	SIMA X	Multi Vboot	Single Vboot	SIMAX / ADD	Multi Vboot
27	20	ON	ON	Debug	01h	1.1 V	35 A	0 V	1.1 V	01h	1.1 V
150	15	ON	ON	Operating	01h	0 V	35 A	0 V	0 V	01h	0 V

1. Suggested values, divider need to be connected between VCC5 pin and GND.
2. The operating mode (SVID bus 25 MHz) is only with Vboot =0 V.
3. The 0 V multi-phase rail Vboot is the only operating mode.
4. If Jmode is OFF and MRO disabled, it is possible to select the single-phase rail maximum current and boot voltage.
5. To select MRO see [Section 6.3.1](#).

### 6.6.2 CONFIG0 in DDR mode (STCOMP=GND)

If the STCOM/DDR pin is short to GND, the device is set in DDR mode.

During startup, the CONFIG0/PSI0 pin works as CONFIG0 pinstrapping, and it is possible to select the following (see [Table 9](#)):

- a) Output voltage: V<sub>OUT</sub> can be selected to support DDR3 (1.5 V/1.35 V) and DDR4 (1.2 V). The only debug mode is for DDR3.
- b) SVID address: the serial VID address can be selected between 02h and 04h for DDR3, while in DDR4 also the SVID address 06h or 08h can be selected. The status of the SVID address can be used with the Address\_Domain (settable by CONFIG1 pinstrapping) to select also the SMBus address for the multi-phase rail and the single-phase rail. See [Table 14](#) for details.
- c) In DDR mode the debug configuration is not settable and SVID is set only in operating mode (CLK to 25 MHz).
- d) SMBus: set SMBus OFF to disable SMBus function. As a consequence pins CONFIG2/SDA and CONFIG3/SCL are used as pinstrapping CONFIG2 and CONFIG3 (see [Section 6.6.5](#) and [Section 6.6.6](#)). If SMBus is set ON, pins CONFIG2/SDA and CONFIG3/SCL are set as serial data (SDA) and serial clock (SCL) used for the SMBus communication (See [Section 7.1](#)).
- e) SWAP mode: set SWAP ON to enter SWAP mode. As a consequence all 3 embedded drivers run for the multi-phase rail (see [Section 6.3](#)).

Table 9. CONFIG0/PSI0 pinstrapping in DDR MODE

Pinstrapping <sup>(1)</sup> divider (KOhm)		Vboot	SVID ADD	SWAP mode	SMBus
R up	R down				
750	10	1.5 V	02h	OFF	OFF
390	16	1.5 V	02h	OFF	ON
390	27	1.5 V	02h	ON	OFF
150	15	1.5 V	02h	ON	ON
91	12	1.5 V	04h	OFF	OFF
91	15	1.5 V	04h	OFF	ON
100	20	1.5 V	04h	ON	OFF
75	18	1.5 V	04h	ON	ON
39	11	1.35 V	02h	OFF	OFF
120	39	1.35 V	02h	OFF	ON
43	16	1.35 V	02h	ON	OFF
120	51	1.35 V	02h	ON	ON
82	39	1.35 V	04h	OFF	OFF
56	30	1.35 V	04h	OFF	ON
20	12	1.35 V	04h	ON	OFF
36	24	1.35 V	04h	ON	ON
27	20	1.2 V	06h	OFF	OFF
68	56	1.2 V	06h	OFF	ON
47	43	1.2 V	06h	ON	OFF
14,7	15	1.2 V	06h	ON	ON
24	27	1.2 V	08h	OFF	OFF
24	30	1.2 V	08h	OFF	ON
13	18	1.2 V	08h	ON	OFF
33	51	1.2 V	08h	ON	ON
36	62	1.2 V	02h	OFF	OFF
39	75	1.2 V	02h	OFF	ON
18	39	1.2 V	02h	ON	OFF
16	39	1.2 V	02h	ON	ON
13	36	1.2 V	04h	OFF	OFF
16	51	1.2 V	04h	OFF	ON
27	100	1.2 V	04h	ON	OFF
18	110	1.2 V	04h	ON	ON

1. Suggested values, divider must be connected between VCC5 pin and GND.

### 6.6.3 CONFIG1 in CPU mode

Config1/PSI1 is a multi-functional pin, during startup it is used as pinstrapping.

Setting the device in CPU mode it is possible to select:

- a) TMAX. Maximum temperature can be set from 90 °C, 100 °C, 110 °C and 120 °C.
- b) IMAX. Maximum current for the multi-phase rail can be selected by pinstrapping as required by Intel specifications. The maximum current can be selected by 4 values which can change depending on the number of the phases selected (see [Section 6.5](#)).
- c) Jmode. It is possible to set Jmode (see [Section 6.4](#)). In MRO mode the single-phase rail remains off and Jmode bitstrapping is used to change the number of switching phases (see [Table 7](#)).

**Table 10. CONFIG1/PSI1 pinstrapping in CPU MODE**

Pinstrapping <sup>(1)</sup> divider (KOhm)		TMAX	IMAX			Jmode
R up	R down		2-phase	3-phase	4-phase	
750	10	90 °C	55 A	65 A	100 A	OFF
390	16	90 °C	55 A	65 A	100 A	ON
390	27	90 °C	60 A	75 A	112 A	OFF
150	15	90 °C	60 A	75 A	112 A	ON
91	12	90 °C	65 A	95 A	120 A	OFF
91	15	90 °C	65 A	95 A	120 A	ON
100	20	90 °C	75 A	112 A	130 A	OFF
75	18	90 °C	75 A	112 A	130 A	ON
39	11	100 °C	55 A	65 A	100 A	OFF
120	39	100 °C	55 A	65 A	100 A	ON
43	16	100 °C	60 A	75 A	112 A	OFF
120	51	100 °C	60 A	75 A	112 A	ON
82	39	100 °C	65 A	95 A	120 A	OFF
56	30	100 °C	65 A	95 A	120 A	ON
20	12	100 °C	75 A	112 A	130 A	OFF
36	24	100 °C	75 A	112 A	130 A	ON
27	20	110 °C	55 A	65 A	100 A	OFF
68	56	110 °C	55 A	65 A	100 A	ON
47	43	110 °C	60 A	75 A	112 A	OFF
14,7	15	110 °C	60 A	75 A	112 A	ON
24	27	110 °C	65 A	95 A	120 A	OFF
24	30	110 °C	65 A	95 A	120 A	ON
13	18	110 °C	75 A	112 A	130 A	OFF

Table 10. CONFIG1/PSI1 pinstrapping in CPU MODE (continued)

Pinstrapping <sup>(1)</sup> divider (KOhm)		TMAX	IMAX			Jmode
R up	R down		2-phase	3-phase	4-phase	
33	51	110 °C	75 A	112 A	130 A	ON
36	62	120 °C	55 A	65 A	100 A	OFF
39	75	120 °C	55 A	65 A	100 A	ON
18	39	120 °C	60 A	75 A	112 A	OFF
16	39	120 °C	60 A	75 A	112 A	ON
13	36	120 °C	65 A	95 A	120 A	OFF
16	51	120 °C	65 A	95 A	120 A	ON
27	100	120 °C	75 A	112 A	130 A	OFF
18	110	120 °C	75 A	112 A	130 A	ON

1. Suggested values, divider must be connected between VCC5 pin and GND.

#### 6.6.4 CONFIG1 in DDR mode (STCOMP=GND)

If the STCOM/DDR pin is short to GND, the device is set in DDR mode.

Using the CONFIG1 pin it is possible to select (see [Table 14](#)):

- TMAX. Maximum temperature can be set between 90 °C and 120 °C.
- Address\_Domain. It is possible to select the SMBus address (see [Table 14](#)).
- IMAX. The multi-phase maximum current can be selected between 2 values according to the number of switching phases of the multi-phase rail.
- Droop. If the droop function is enabled, the current on the FB pin is 50% of the total current read ([Section 8.2](#)).
- Jmode. Jmode configuration can be set (see [Section 6.4](#)). In MRO mode single-phase rail remains off and by setting Jmode it is possible to change the multi-phase rail switching phase number (see [Table 7](#)).

Table 11. CONFIG1/PSI1 pinstrapping in DDR MODE

Pinstrapping <sup>(1)</sup> divider (KOhm)		TMAX	Add/ DOM	IMAX			Droop	Jmode
R up	R down			2-phase	3-phase	4-phase		
750	10	90 °C	0	54 A	66 A	76 A	OFF	OFF
390	16	90 °C	0	54 A	66 A	76 A	OFF	ON
390	27	90 °C	0	54 A	66 A	76 A	ON	OFF
150	15	90 °C	0	54 A	66 A	76 A	ON	ON
91	12	90 °C	0	66 A	76 A	88 A	OFF	OFF
91	15	90 °C	0	66 A	76 A	88 A	OFF	ON
100	20	90 °C	0	66 A	76 A	88 A	ON	OFF

Table 11. CONFIG1/PSI1 pinstrapping in DDR MODE (continued)

Pinstrapping <sup>(1)</sup> divider (KOhm)		TMAX	Add/ DOM	IMAX			Droop	Jmode
R up	R down			2-phase	3-phase	4-phase		
75	18	90 °C	0	66 A	76 A	88 A	ON	ON
39	11	90 °C	1	54 A	66 A	76 A	OFF	OFF
120	39	90 °C	1	54 A	66 A	76 A	OFF	ON
43	16	90 °C	1	54 A	66 A	76 A	ON	OFF
120	51	90 °C	1	54 A	66 A	76 A	ON	ON
82	39	90 °C	1	66 A	76 A	88 A	OFF	OFF
56	30	90 °C	1	66 A	76 A	88 A	OFF	ON
20	12	90 °C	1	66 A	76 A	88 A	ON	OFF
36	24	90 °C	1	66 A	76 A	88 A	ON	ON
27	20	120 °C	0	54 A	66 A	76 A	OFF	OFF
68	56	120 °C	0	54A	66A	76A	OFF	ON
47	43	120 °C	0	54 A	66 A	76 A	ON	OFF
14,7	15	120 °C	0	54 A	66 A	76 A	ON	ON
24	27	120 °C	0	66 A	76 A	88 A	OFF	OFF
24	30	120 °C	0	66 A	76 A	88 A	OFF	ON
13	18	120 °C	0	66 A	76 A	88 A	ON	OFF
33	51	120 °C	0	66 A	76 A	88 A	ON	ON
36	62	120 °C	1	54 A	66A	76 A	OFF	OFF
39	75	120 °C	1	54 A	66 A	76 A	OFF	ON
18	39	120 °C	1	54 A	66 A	76 A	ON	OFF
16	39	120 °C	1	54 A	66 A	76 A	ON	ON
13	36	120 °C	1	66 A	76 A	88 A	OFF	OFF
16	51	120 °C	1	66 A	76 A	88 A	OFF	ON
27	100	120 °C	1	66 A	76 A	88 A	ON	OFF
18	110	120 °C	1	66 A	76 A	88 A	ON	ON

1. Suggested values, divider must be connected between VCC5 pin and GND.

### 6.6.5 CONFIG2

If the SMBus is disabled by CONFIG0, the CONFIG2/SDA pin is set as pinstrapping CONFIG2. In this condition it is possible to select the OVP and OFFSET of the multi-phase and single rail (see [Table 12](#)).

The overvoltage protection can be set in tracking mode.  $OVP = VID + OFFSET + Threshold$ . Threshold can be selected between +175 mV and +500 mV.

External offset can be added to the internal voltage reference VID on both sections (no offset, 100 mV, 200 mV, 300 mV).

**Table 12. CONFIG2/SDA pinstrapping**

Pinstrapping <sup>(1)</sup> divider (KOhm)		OVP (above VID+OFFSET)	Offset multi-rail	Offset single-rail
R up	R down			
750	10	+500 mV	No offset	No offset
390	16	+500 mV	No offset	+100 mV
390	27	+500 mV	No offset	+200 mV
150	15	+500 mV	No offset	+300 mV
91	12	+500 mV	+100 mV	No offset
91	15	+500 mV	+100 mV	+100 mV
100	20	+500 mV	+100 mV	+200 mV
75	18	+500 mV	+100 mV	+300 mV
39	11	+500 mV	+200 mV	No offset
120	39	+500 mV	+200 mV	+100 mV
43	16	+500 mV	+200 mV	+200 mV
120	51	+500 mV	+200 mV	+300 mV
82	39	+500 mV	+300 mV	No offset
56	30	+500 mV	+300 mV	+100 mV
20	12	+500 mV	+300 mV	+200 mV
36	24	+500 mV	+300 mV	+300 mV
27	20	+175 mV	No offset	No offset
68	56	+175 mV	No offset	+100 mV
47	43	+175 mV	No offset	+200 mV
14,7	15	+175 mV	No offset	+300 mV
24	27	+175 mV	+100 mV	No offset
24	30	+175 mV	+100 mV	+100 mV
13	18	+175 mV	+100 mV	+200 mV
33	51	+175 mV	+100 mV	+300 mV
36	62	+175 mV	+200 mV	No offset
39	75	+175 mV	+200 mV	+100 mV
18	39	+175 mV	+200 mV	+200 mV
16	39	+175 mV	+200 mV	+300 mV
13	36	+175 mV	+300 mV	No offset
16	51	+175 mV	+300 mV	+100 mV

**Table 12. CONFIG2/SDA pinstrapping (continued)**

Pinstrapping (1) divider (KOhm)		OVP (above VID+OFFSET)	Offset multi-rail	Offset single-rail
R up	R down			
27	100	+175 mV	+300 mV	+200 mV
18	110	+175 mV	+300 mV	+300 mV

1. Suggested values, divider must be connected between VCC5 pin and GND.

### 6.6.6 CONFIG3

If the SMBus is disabled by CONFIG0, it is possible to use the CONFIG3/SCL pin as pinstrapping CONFIG3. In this condition it is possible to select the OCP, VFDE, DPM strategy and enable.

Using CONFIG3 pinstrapping it is possible to set:

- a) OCP - The average overcurrent can be selected between 125% and 137% of IMAX in both sections (see [Section 9.2](#)).
- b) DPM strategy - If DPM is enabled, the device performs the automatic phase shading on the multi-phase rail (see [Section 7.3](#)). The phase cutting follows the strategy selected in percentage of IMAX based on voltage sensed on the IMON pin.
- c) VFDE - Variable frequency diode emulation can be enabled/disabled. ULTRASONIC limits the switching frequency to 30 KH (see [Section 7.4](#)).
- d) DPMEN - Automatic dynamic phase management (see [Section 7.3](#)) of the multi-phase rail can be enabled or disabled when the system runs in PS0. In PS1 the L6718 switches, from 2-phase to 1-phase, a threshold of 15% of IMAX even if DPMEN is disabled.

With DPM off it is possible to disable the droop function.

**Table 13. CONFIG3/SCL pinstrapping**

Pinstrapping (1) divider (KOhm)		OCP(2)	DPM strategy (2)			VFDE enable	DPM enable	DROOP
R up	R down		1ph- >2ph	2ph- >3ph	3ph- >4ph			
750	10	125%	15%			OFF	OFF	ON
390	16	125%	15%	25%	40%	OFF	ON	ON
390	27	125%	15%			ON	OFF	OFF
150	15	125%	15%	25%	40%	ON	ON	ON
91	12	125%	15%			OFF	OFF	ON
91	15	125%	20%	30%	45%	OFF	ON	ON
100	20	125%	20%			ON	OFF	OFF
75	18	125%	20%	30%	45%	ON	ON	ON



Table 13. CONFIG3/SCL pinstrapping (continued)

Pinstrapping <sup>(1)</sup> divider (KOhm)		OCP <sup>(2)</sup>	DPM strategy <sup>(2)</sup>			VFDE enable	DPM enable	DROOP
R up	R down		1ph- >2ph	2ph- >3ph	3ph- >4ph			
39	11	125%	25%			OFF	OFF	ON
120	39	125%	25%	35%	50%	OFF	ON	ON
43	16	125%	25%			ON	OFF	OFF
120	51	125%	25%	35%	50%	ON	ON	ON
82	39	125%	30%			OFF	OFF	ON
56	30	125%	30%	40%	55%	OFF	ON	ON
20	12	125%	30%			ON	OFF	OFF
36	24	125%	30%	40%	55%	ON	ON	ON
27	20	137%	15%			OFF	OFF	ON
68	56	137%	15%	25%	40%	OFF	ON	ON
47	43	137%	15%			ON	OFF	OFF
14,7	15	137%	15%	25%	40%	ON	ON	ON
24	27	137%	20%			OFF	OFF	ON
24	30	137%	20%	30%	45%	OFF	ON	ON
13	18	137%	20%			ON	OFF	OFF
33	51	137%	20%	30%	45%	ON	ON	ON
36	62	137%	25%			OFF	OFF	ON
39	75	137%	25%	35%	50%	OFF	ON	ON
18	39	137%	25%			ON	OFF	OFF
16	39	137%	25%	35%	50%	ON	ON	ON
13	36	137%	30%			OFF	OFF	ON
16	51	137%	30%	40%	55%	OFF	ON	ON
27	100	137%	30%			ON	OFF	OFF
18	110	137%	30%	40%	55%	ON	ON	ON

1. Suggested values, divider must be connected between VCC5 pin and GND.

2. In percentage of IMAX.

## 7 L6718 power manager

The L6718 power manager, configured by pins CONFIG2/SCL and CONFIG3/SDA, provides a large number of configuration settings and monitoring to increase the performance of both rails of the step-down DC-DC voltage regulator.

These pins can be configured in 2 different modes by setting ON/OFF the SMBus by CONFIG0 pinstrapping (see [Section 6.6.1](#) and [Section 6.6.2](#) for details).

- SCL and SDA (if SMBus is set ON): power management is provided from a master with SMBus communication interface through two-wire clock (SCL) and data (SDA) which guarantee a high level programmability (setting and monitoring) while the system is running.
- CONFIG2 and CONFIG 3 (if SMBus is set OFF): power management is provided with 2 pinstrappings set during the startup (see [Section 6.6.5](#) and [Section 6.6.6](#) for details).

### 7.1 SMBus power manager

The SMBus interface is set by CONFIG0 pinstrapping. The L6718 features a second power manager bus to easily implement power management features as well as overspeeding while the application is running. The power manager SMBus is operative after VREADY is driven high at the end of the soft-start.

Once the controller is predisposed to use the SMBus interface, CONFIG2/SCL and CONFIG3/SDA pins are set as digital input clock (SCL) and data (SDA).

SMBus interface communication is based on a two-wire clock and data which connect a master to one or more slaves addressed separately. The master starts the SMBus transaction and drives the clock and the data signals. The slave (L6718) receives the transaction and acts accordingly. In the case of a reading command, the slave drives the data signal to reply to the bus with a byte or a word.

The L6718 SMBus address for multi-phase and single-phase rails can be selected at startup by the choice of the configuration mode and pinstrapping (see [Table 14](#)).

In CPU mode the SMBus address depends on the choice of SVID address which is 00h typically but can be selected to 01h only in MRO (see [Section 6.3.1](#)).

In DDR mode the SMBus address depends on the status of Add\_Dom selectable from CONFIG1 pinstrapping (see [Section 6.6.4](#)).

The single-phase rail in DDR mode can be addressed only in Jmode.

The L6718 SMBus commands are able to change dynamically the status of the voltage regulator, the DPM strategy, the VFDE, and some protection thresholds, as shown in [Table 15](#).

Power SMBus protocol is based on the system management bus (SMBus) specification ver. 2.0 which can run up to 400 kHz.

Cycling VCC resets the register to the default configuration.

### 7.1.1 SMBus sequence

The bus master sends the start (START) sequence followed by 7 bits which identify the controller address. The bus master then sends READ/WRITE and the controller then sends the acknowledge (ACK) bit.

The bus master sends the command code during the command phase. The controller sends the acknowledge bit after the command phase.

If a READ command is sent by the master, the device drives the SDA wire in order to reply to the master request with DATA BYTE or DATA WORD (2 bytes) depending on the command. The controller sends the acknowledge (ACK) bit after the data stream. Finally, the bus master sends the stop (STOP) sequence.

WRITE command: The master sends the data stream related to the command phase previously issued (if applicable). The controller achieves the data stream by the masters and sends the acknowledge (ACK). Finally the bus master sends the stop (STOP) sequence.

After the controller has detected the STOP sequence, it performs operations according to the command issued by the master.

Figure 8. SMBus communication format

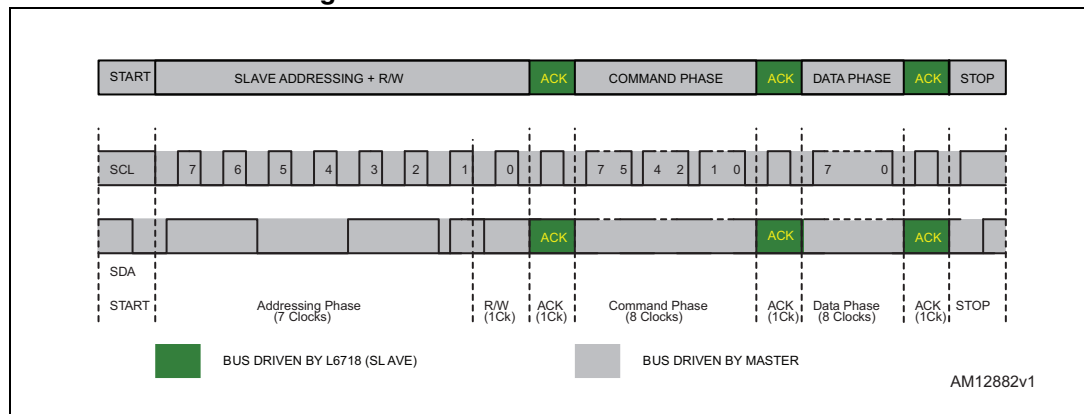

## 7.2 SMBus tables

Table 14. SMBus addressing

Mode	VRM address	Address domain	SMBus multi-phase	SMBus single-phase
CPU mode	00h	-	CCh	8Ch
CPU mode	01h	-	CEh	8Eh
DDR mode	02h (06h in DDR4)	0	E0h	E2h (Jmode only)
DDR mode	02h (06h in DDR4)	1	E8h	EAh (Jmode only)
DDR mode	04h (08h in DDR4)	0	E4h	E6h (Jmode only)
DDR mode	04h (08h in DDR4)	1	ECh	EEh (Jmode only)

Table 15. SMBus interface commands

Command code	Command name and type	Body type	Description
D0h	SetVID Read/Write	8b byte	Sets $V_{OUT}$ , refer to <a href="#">Table 16: SMBus VID</a> Default 00h
D1h	VOUTMAX Read/Write	8b byte	Sets maximum limit for $V_{OUT} = VID + OFFSET$ . It is not related to VR12 register. Default BFh (2.145 V)
D2h	DOMAIN Read/Write	1b byte	If bit0="0", VR12 SVID sets $V_{OUT}$ . If bit0="1", SMBus interface is able to set $V_{OUT}$ through SetVID command and bypass the SVID bus indication. Default 00h
D3h	DPMTH1 Read/Write	8b byte	Sets the DPM threshold from 1-phase switching to 2-phase switching in percentage of I <sub>MAX</sub> . Default 26h (15% I <sub>MAX</sub> )
D4h	DPMTH2 Read/Write	8b byte	Sets the DPM threshold from 2-phase switching to 3-phase switching in percentage of I <sub>MAX</sub> . Default 40h (25% I <sub>MAX</sub> )
D5h	DPMTH3 Read/Write	8b byte	Sets the DPM threshold from 3-phase switching to 4-phase switching in percentage of I <sub>MAX</sub> . Default 66h (40% I <sub>MAX</sub> )
D6h	OVP Read/Write	1b byte	If bit0="0" : OVP is set to VID+OFFSET+500 mV If bit0="1" : OVP is set to VID+OFFSET+175 mV Default 00h (+500 mV)
D7h	OCP Read/Write	1b byte	If bit0="0" : OCP is set to 125% of I <sub>MAX</sub> If bit0="1" : OCP is set to 137% of I <sub>MAX</sub> Default 00h (125%)
D8h	DROOP Read/Write	2b byte	If bit1 and bit0="00" : DROOP is set ON to 100% If bit1 and bit0="01" : DROOP is set ON to 50% If bit1 and bit0="11" : DROOP is set OFF Default 00h (100%DROOP)
D9h	CONFIG Read/Write	5b byte	If bit0="1", a minimal switching frequency in VFDE is enabled, otherwise VFDE has no down limitation. If bit1="1", VFDE is enabled, otherwise VFDE is disabled. If bit2="1", DPM is enabled in PS0 with the default threshold, otherwise it is disabled (only core feature). If bit3="1", DPM is enabled in PS1 and the device can change from 2 to 1-phase switching with the default threshold (DPMTH1), otherwise it is disabled (only core feature). If bit4="1", the device uses 2-phase switching in PS1, otherwise the device uses 1-phase (only core feature). Default multi-phase rail 1Bh Default single-phase rail 0Bh

Table 15. SMBus interface commands (continued)

Command code	Command name and type	Body type	Description
DAh	OFFSET Read/Write	8b byte	Bit 0-6 adds an offset to VID with steps of 5 mV. If bit7="1", the offset is positive, otherwise the offset is negative. Default 80h (no offset)
DBh	VOUT Read	8b byte	L6718 replies with the value of the VID setting following the VR12 tab.
DCh	IOUT Read	8b byte	L6718 replies with the value I <sub>OUT</sub> as percentage of IMAX. FFh is 100%.
DEh	VR12_PS Read	2b byte	Reports the actual power state configuration.
80h	STATUS Read	1b byte	If bit0="1", VREADY is set. If bit1="1", Feedback disconnection latched. If bit2="1", OVP protection latched. If bit3="1", UVP protection latched. If bit4="1", VRHOT protection latched. If bit5="1", OCP protection latched. If bit6 and bit7 show the phase number (4ph=11). Default multi-phase rail running 41h(2ph); 81h(3ph); C1h(4ph) Default single-phase rail running 41h.
E9h	MODEL_ID Read	16b word	Reports the internal model ID for GUI = C05Ah.

Table 16. SMBus VID

HEX Code	VOUT [V]	HEX Code	VOUT [V]	HEX Code	VOUT [V]	HEX Code	VOUT [V]			
0	0	0.00	4	0	0.885	8	0	1.525	C	0
0	1	0.255	4	1	0.895	8	1	1.535	C	1
0	2	0.265	4	2	0.905	8	2	1.545	C	2
0	3	0.275	4	3	0.915	8	3	1.555	C	3
0	4	0.285	4	4	0.925	8	4	1.565	C	4
0	5	0.295	4	5	0.935	8	5	1.575	C	5
0	6	0.305	4	6	0.945	8	6	1.585	C	6
0	7	0.315	4	7	0.955	8	7	1.595	C	7
0	8	0.325	4	8	0.965	8	8	1.605	C	8
0	9	0.335	4	9	0.975	8	9	1.615	C	9
0	A	0.345	4	A	0.985	8	A	1.625	C	A
0	B	0.355	4	B	0.995	8	B	1.635	C	B

Table 16. SMBus VID (continued)

HEX Code		VOUT [V]	HEX Code		VOUT [V]	HEX Code		VOUT [V]	HEX Code	
0	C	0.365	4	C	1.005	8	C	1.645	C	C
0	D	0.375	4	D	1.015	8	D	1.655	C	D
0	E	0.385	4	E	1.025	8	E	1.665	C	E
0	F	0.395	4	F	1.035	8	F	1.675	C	F
1	0	0.405	5	0	1.045	9	0	1.685	D	0
1	1	0.415	5	1	1.055	9	1	1.695	D	1
1	2	0.425	5	2	1.065	9	2	1.705	D	2
1	3	0.435	5	3	1.075	9	3	1.715	D	3
1	4	0.445	5	4	1.085	9	4	1.725	D	4
1	5	0.455	5	5	1.095	9	5	1.735	D	5
1	6	0.465	5	6	1.105	9	6	1.745	D	6
1	7	0.475	5	7	1.115	9	7	1.755	D	7
1	8	0.485	5	8	1.125	9	8	1.765	D	8
1	9	0.495	5	9	1.135	9	9	1.775	D	9
1	A	0.505	5	A	1.145	9	A	1.785	D	A
1	B	0.515	5	B	1.155	9	B	1.795	D	B
1	C	0.525	5	C	1.165	9	C	1.805	D	C
1	D	0.535	5	D	1.175	9	D	1.815	D	D
1	E	0.545	5	E	1.185	9	E	1.825	D	E
1	F	0.555	5	F	1.195	9	F	1.835	D	F
2	0	0.565	6	0	1.205	A	0	1.845	E	0
2	1	0.575	6	1	1.215	A	1	1.855	E	1
2	2	0.585	6	2	1.225	A	2	1.865	E	2
2	3	0.595	6	3	1.235	A	3	1.875	E	3
2	4	0.605	6	4	1.245	A	4	1.885	E	4
2	5	0.615	6	5	1.255	A	5	1.895	E	5
2	6	0.625	6	6	1.265	A	6	1.905	E	6
2	7	0.635	6	7	1.275	A	7	1.915	E	7
2	8	0.645	6	8	1.285	A	8	1.925	E	8
2	9	0.655	6	9	1.295	A	9	1.935	E	9
2	A	0.665	6	A	1.305	A	A	1.945	E	A
2	B	0.675	6	B	1.315	A	B	1.955	E	B
2	C	0.685	6	C	1.325	A	C	1.965	E	C
2	D	0.695	6	D	1.335	A	D	1.975	E	D
2	E	0.705	6	E	1.345	A	E	1.985	E	E

Table 16. SMBus VID (continued)

HEX Code		VOUT [V]	HEX Code		VOUT [V]	HEX Code		VOUT [V]	HEX Code	
2	F	0.715	6	F	1.355	A	F	1.995	E	F
3	0	0.725	7	0	1.365	B	0	2.005	F	0
3	1	0.735	7	1	1.375	B	1	2.015	F	1
3	2	0.745	7	2	1.385	B	2	2.025	F	2
3	3	0.755	7	3	1.395	B	3	2.035	F	3
3	4	0.765	7	4	1.405	B	4	2.045	F	4
3	5	0.775	7	5	1.415	B	5	2.055	F	5
3	6	0.785	7	6	1.425	B	6	2.065	F	6
3	7	0.795	7	7	1.435	B	7	2.075	F	7
3	8	0.805	7	8	1.445	B	8	2.085	F	8
3	9	0.815	7	9	1.455	B	9	2.095	F	9
3	A	0.825	7	A	1.465	B	A	2.105	F	A
3	B	0.835	7	B	1.475	B	B	2.115	F	B
3	C	0.845	7	C	1.485	B	C	2.125	F	C
3	D	0.855	7	D	1.495	B	D	2.135	F	D
3	E	0.865	7	E	1.505	B	E	2.145	F	E
3	F	0.875	7	F	1.515	B	F	2.155	F	F

## 7.3 DPM

Dynamic phase management allows the number of working phases to be adjusted according to the delivered current while still maintaining the benefits of the multi-phase regulation in order to achieve high efficiency performance.

Phase number is reduced by monitoring the voltage level across the IMON pin: the L6718 reduces the number of working phases according to the DPM strategy.

In order to reach the right DPM threshold, the IMON resistor (between IMON pin and GND) must be designed to reach 1.24 V when I<sub>MAX</sub> is applied by the load. A hysteresis (50 mV typ.) is provided for each threshold in order to avoid multiple DPM actions triggering in steady load conditions.

Different DPM thresholds can be selected by SMBus or CONFIG3 pinstrapping to match the application with the best efficiency performance.

When DPM is enabled, the L6718 starts monitoring the IMON voltage for phase number modifications after VR\_RDY has transition high: the soft-start is then implemented in interleaving mode with all the available phases enabled.

DPM is reset in the case of a SetVID command that affects the CORE section and when LTB Technology detects a load transient. After being reset, if the voltage across IMON is compatible, DPM is re-enabled after a proper delay.

Delay in the intervention of DPM can be set using a filter capacitor on the IMON pin. Higher capacitance can be used to increase the DPM intervention delay.

### 7.4 VFDE

In both rails, if the delivered current is low that the CCM/DCM boundary is reached, the controller is able to enter variable frequency diode emulation. As a consequence, the switching frequency decreases in order to reach high efficiency performance.

In a common single-phase DC-DC converter, the boundary between CCM and DCM is when the delivered current is perfectly equal to 1/2 of the peak-to-peak ripple in the inductor ( $I_{OUT} = I_{pp}/2$ ). A further decrease of the load in this condition, maintaining CCM operation, would cause the current in the inductor to reverse, therefore sinking the current from the output for a part of the off-time. This results in a poor efficiency system.

The L6718 is able (via CSPx/CSNx pins) to detect the sign of the current across the inductor (zero cross detection, ZCD) so it is able to recognize when the delivered current approaches the CCM/DCM boundary. In VFDE operation, the controller fires the high-side MOSFET for a TON and the low-side MOSFET for a TOFF (the same as when the controller works in CCM mode) and waits the necessary time until next firing in high-impedance (HiZ). The consequence of this behavior is a linear reduction of the “apparent” switching frequency that, in turn, results in an improvement of the efficiency of the converter when in very light load conditions.

To prevent entering into the audible range, the “apparent” switching frequency is reduced to around 30 kHz by default, but this function can be disabled using the SMBus interface in order to reach an even lower switching frequency.

Using the SMBus interface, VFDE (enable by default) can easily turn on/off on each rail while, with SMBus OFF, it is possible to enable/disable VFDE by CONFIG3 for both rails.

When SWAP mode is enabled, the VFDE is disabled in the single-rail section and any configuration command for this rail (by SMBus or pinstrapping) is ignored.

Figure 9. Output current vs. switching frequency in PSK mode

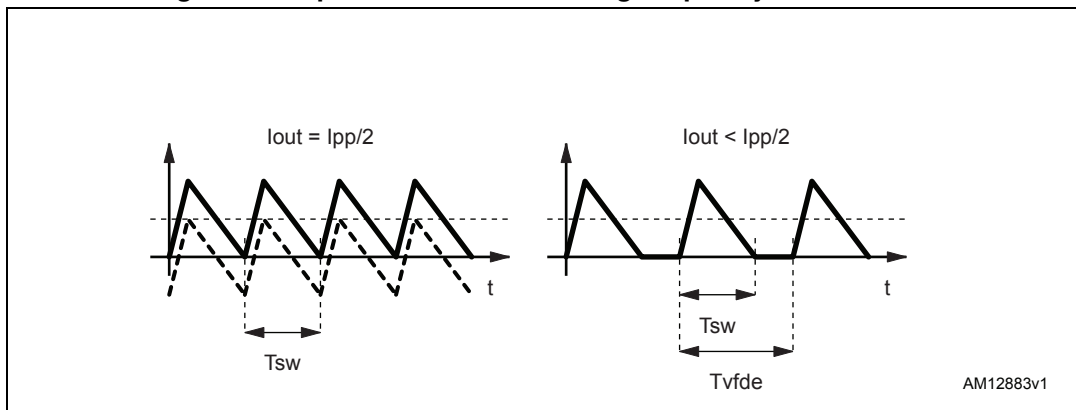



## 7.5 Power state indicator (PSI)

The L6718 offers the possibility to monitor the power state status of the multi-phase rail pins CONFIG0/PSI0 and CONFIG1/PSI1.

Since the pinstrapping configuration is set during the startup, once VREADY is pulled high the L6718 uses an internal push/pull on these pins to monitor the device power status.

From these pins, power state (PS0, PS1, PS2, PS3) is provided as digital output (see [Table 17](#)).

**Table 17. Power status**

PSI1	PSI0	PS
1	1	PS0
1	0	PS1
0	1	PS2
0	0	PS3

## 8 Output voltage positioning

Output voltage positioning is performed by selecting the controller operative-mode (*CPU*, *DDR*, *GPU*, *Jmode*, see [Section 7](#) for details) for the two sections and by programming the droop function effect (see [Figure 10](#)). The controller reads the current delivered by each section by monitoring the voltage drop across the DCR inductors. The current ( $I_{DROOP}$  /  $I_{SDROOP}$ ) sourced from the FB/SFB pins, directly proportional to the read current, causes the related section output voltage to vary according to the external  $R_{FB}$  /  $R_{SFB}$  resistor, therefore implementing the desired load-line effect.

In DDR mode it is possible to disable or to decrease the droop effect by using CONFIG1 pinstrapping (see [Section 6.6.4](#) for details).

The L6718 embeds a dual remote-sense buffer to sense remotely the regulated voltage of each section without any additional external components. In this way, the output voltage programmed is regulated compensating for board and socket losses. Keeping the sense traces parallel and guarded by a power plane results in common mode coupling for any picked-up noise.

Figure 10. Voltage positioning

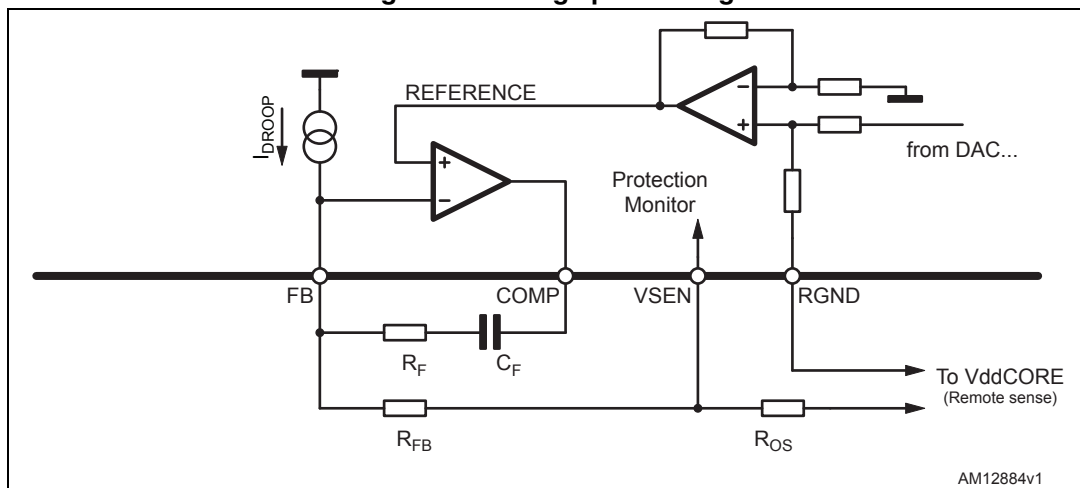

### 8.1 Multi-phase section - current reading and current sharing loop

The L6718 embeds a flexible, fully-differential current sense circuitry that is able to read across the inductor parasitic resistance or across a sense resistor placed in series to the inductor element. The fully-differential current reading rejects noise and allows the placing of sensing elements in different locations without affecting the measurement accuracy. The trans-conductance ratio is issued by the external resistor  $R_G$  placed outside the chip between the CSxN pin toward the reading points. The current sense circuit always tracks the current information, the pin CSxP is used as a reference keeping the CSxN pin to this voltage. To correctly reproduce the inductor current, an R-C filtering network must be introduced in parallel to the sensing element. The current that flows from the CSxN pin is then given by the following equation (see [Figure 11](#)):

**Equation 1**

$$I_{CSxN} = \frac{DCR}{R_G} \cdot \frac{1 + s \cdot L / DCR}{1 + s \cdot R \cdot C} \cdot I_{PHASEx}$$

Considering now the matching of the time constant between the inductor and the R-C filter applied (time constant mismatches cause the introduction of poles into the current reading network causing instability. In addition, it is also important for the load transient response and to let the system show resistive equivalent output impedance) it results:

**Equation 2**

$$\frac{L}{DCR} = R \cdot C \Rightarrow I_{CSxN} = \frac{R_L}{R_G} \cdot I_{PHASEx} = I_{INFOx}$$

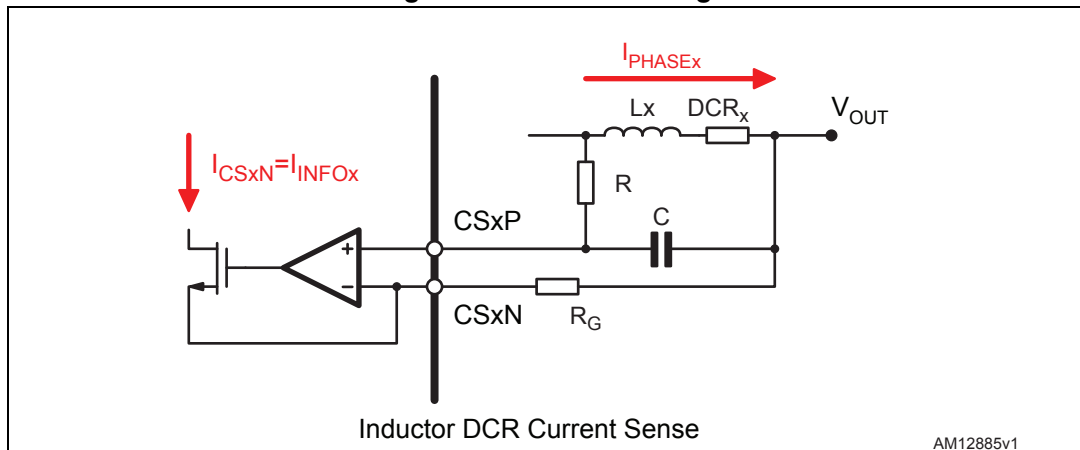
**Figure 11. Current reading**

The current read through the CSxP / CSxN pairs is converted into a current  $I_{INFOx}$  proportional to the current delivered by each phase and the information regarding the average current  $I_{AVG} = \Sigma I_{INFOx} / N$  is internally built into the device (N is the number of working phases). The error between the read current  $I_{INFOx}$  and the reference  $I_{AVG}$  is then converted into a voltage that, with a proper gain, is used to adjust the duty cycle whose dominant value is set by the voltage error amplifier in order to equalize the current carried by each phase.

**8.2 Multi-phase section - defining load-line**

The L6718 introduces a dependence of the output voltage on the load current recovering part of the drop due to the output capacitor ESR in the load transient. Introducing a dependence of the output voltage on the load current, a static error, proportional to the output current, causes the output voltage to vary according to the sensed current.

*Figure 11* shows the current sense circuit used to implement the load-line. The current flowing across the inductor(s) is read through the R-C filter across the CSxP and CSxN pins.  $R_G$  programs a trans-conductance gain and generates a current  $I_{CSx}$  proportional to the current of the phase. The sum of the  $I_{CSx}$  current is then sourced by the FB pin ( $I_{DROOP}$ ).  $R_{FB}$  gives the final gain to program the desired load-line slope (*Figure 10*).

Time constant matching between the inductor (L/DCR) and the current reading filter (RC) is required to implement a real equivalent output impedance of the system, therefore avoiding over and/or undershoot of the output voltage as a consequence of a load transient. The output voltage characteristic vs. load current is then given by:

#### Equation 3

$$V_{OUT} = VID - R_{FB} \cdot I_{DROOP} = VID - R_{FB} \cdot \frac{DCR}{R_G} \cdot I_{OUT} = VID - R_{LL} \cdot I_{OUT}$$

where  $R_{LL}$  is the resulting load-line resistance implemented by the multi-phase section. The  $R_{FB}$  resistor can then be designed according to the  $R_{LL}$  specifications, as follows:

#### Equation 4

$$R_{FB} = R_{LL} \cdot \frac{R_G}{DCR}$$

### 8.3 Single-phase section - current reading

The single-phase section performs the same differential current reading across DCR as the multi-phase section. According to [Section 8.1](#), the current that flows from the SCSN pin is then given by the following equation (see [Figure 11](#)):

#### Equation 5

$$I_{SCSN} = \frac{DCR}{R_{SG}} \cdot I_{SOUT} = I_{SDROOP}$$

### 8.4 Single-phase section - defining load-line

This method introduces a dependence of the output voltage on the load current recovering part of the drop due to the output capacitor ESR in the load transient. Introducing a dependence of the output voltage on the load current, a static error, proportional to the output current, causes the output voltage to vary according to the sensed current.

[Figure 11](#) shows the current sense circuit used to implement the load-line. The current flowing across the inductor DCR is read through  $R_{SG}$ . This resistor programs a trans-conductance gain and generates a current  $I_{SDROOP}$  proportional to the current delivered by the single-phase section that is then sourced from the SFB pin.  $R_{SFB}$  gives the final gain to program the desired load-line slope ([Figure 10](#)).

The output characteristic vs. load current is then given by:

#### Equation 6

$$V_{SOUT} = VID - R_{SFB} \cdot I_{SDROOP}$$

where  $R_{SLL}$  is the resulting load-line resistance implemented by the single-phase section.

The  $R_{SFB}$  resistor can then be designed according to the  $R_{SLL}$ , as follows:

**Equation 7**

$$R_{SFB} = R_{SLL} \cdot \frac{R_{SG}}{DCR}$$

## 8.5 Dynamic VID transition support

The L6718 manages dynamic VID transitions that allow the output voltage of both sections to be modified during normal device operation for power management purposes.

When changing dynamically the regulated voltage (DVID), the system must charge or discharge the output capacitor accordingly. This means that an extra-current  $I_{DVID}$  needs to be delivered (especially when increasing the output regulated voltage) and it must be considered when setting the overcurrent threshold of both the sections. This current results:

**Equation 8**

$$I_{DVID} = C_{OUT} \cdot \frac{dV_{OUT}}{dT_{VID}}$$

where  $dV_{OUT} / dT_{VID}$  depends on the specific command issued (10 mV/ $\mu$ sec. for SetVID\_Fast and 2.5 mV/ $\mu$ sec. for SetVID\_Slow).

Overcoming the OC threshold during the dynamic VID causes the device to latch and disable.

As soon as the controller receives a new valid command to set the VID level for one (or both) of the two sections, the reference of the involved section steps up or down according to the target-VID with the programmed slope until the new code is reached. If a new valid command is issued during the transition, the device updates the target-VID level and performs the dynamic transition up to the new code. Protection is increased during the transition and re-activated with proper delay after the end of the transition to prevent false triggering.

## 8.6 DVID optimization: REF/SREF

High slew rate for dynamic VID transitions cause overshoot and undershoot on the regulated voltage, causing a violation of the microprocessor requirement. To compensate this behavior and to remove any over/undershoot in the transition, each section features a DVID optimization circuit.

The reference used for the regulation is available on the REF/SREF pins (see [Figure 12](#)). Connect an  $R_{REF}/C_{REF}$  to GND ( $R_{SREF} / C_{SREF}$  for the single-phase) to optimize the DVID behavior. Components may be designed as follows (multi-phase, same equations apply to single-phase):

**Equation 9**

$$C_{REF} = C_F \cdot \left( 1 - \frac{\Delta V_{OSC}}{k_V \cdot V_{IN}} \right)$$

$$R_{REF} = \frac{R_F \cdot C_F}{C_{REF}}$$

where  $\Delta V_{osc}$  is the PWM ramp and  $k_V$  the gain for the voltage loop (see [Figure 12](#)).

During a DVID transition, the REF pin moves according to the command issued (SetVIDFast, SetVIDSlow); the current requested to charge/discharge the  $R_{REF}/C_{REF}$  network is mirrored and added to the droop current compensating for over/undershoot on the regulated voltage.

If Jmode is enabled by CONFIG1 pinstrapping the SREF/JEN is set as the single-phase rail enable.

**Figure 12. DVID optimization circuit**

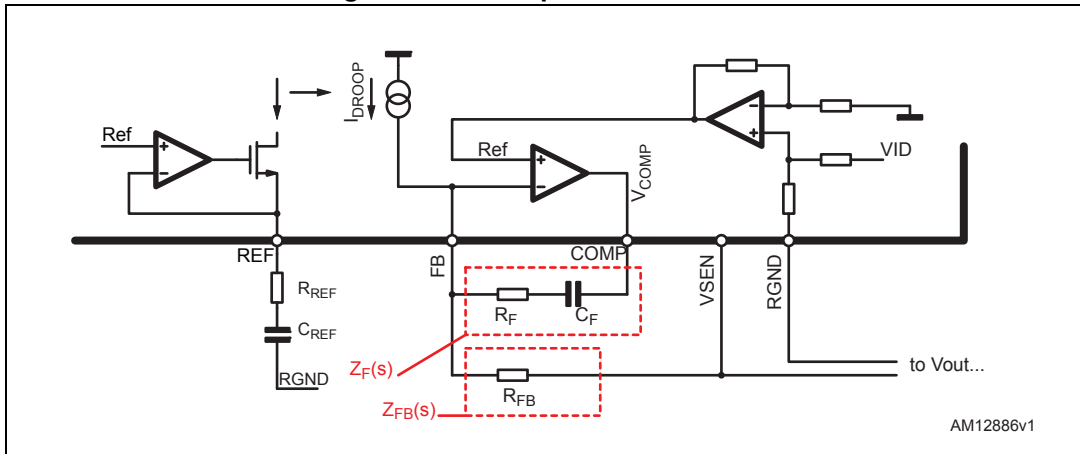

## 9 Output voltage monitoring and protection

The L6718 includes a complete set of protections: overvoltage, undervoltage, feedback disconnection, overcurrent total and overcurrent per-phase.

The device monitors the voltage on the VSEN pin in order to manage OV, UV and feedback disconnection while CS1- reads the voltage in order to detect VSEN disconnection. The IMON pin is used to monitor total overcurrent and it shows different thresholds for different operative conditions.

The device shows different thresholds when in different operative conditions but the behavior in response to a protection event is still the same as described below.

Protection is active also during soft-start while it is properly increased during DVID transitions with an additional delay to avoid false triggering.

Once the protection latches the device, a VCC cycle or enable cycle is needed to restart the system. If protection occurs while the SMBus interface is used, a VCC cycle is necessary to discharge the embedded register and reboot the system.

**Table 18. L6718 protection at a glance**

	Section	
	Multi-phase	Single-phase
<i>Overvoltage (OV)</i>	VSEN, SVSEN = +175/500 mV above Vref + Offset <b>Action:</b> IC Latch; LS=ON & PWMx = 0 if required to keep the regulation to 250 mV; Other section: HiZ.	
<i>Undervoltage (UV)</i>	VSEN, SVSEN = 500 mV below reference. Active after Ref > 500 mV <b>Action:</b> IC Latch; both sections HiZ.	
<i>Overcurrent (OC)</i>	Current monitor across inductor DCR. Dual protection, per-phase and average. <b>Action:</b> UV-Like.	
Feedback disconnection VSEN & FBG	VSEN or FBG not connected. <b>Action:</b> IC Latch HiZ.	

### 9.1 Overvoltage

During the soft-start or DVID, OVP threshold is fixed to 1.8 V, or 2.4 V if any offset is present, until the VREADY is set, OVP then moves in tracking mode.

The OVP threshold is in tracking mode for both sections and it considers also an offset set by SMBus or pinstrapping.

OVP is fixed if V<sub>OUT</sub> is set lower than 0.5 V. In this case, the OVP is set to 1.8 V with no offset added or 2.4 V if offset is used.

When the voltage sensed by VSEN and/or SVSEN overcomes the OV threshold, the controller acts in order to protect the load from excessive voltage levels, avoiding any

possible undershoot. To reach this target, a special sequence is performed, as per the following:

- The device turns on all low-side MOSFETs (and keeps to GND the PWMx) of the section where OV protection is triggered. At the same time the device performs a fast DVID moving the internal reference to 250 mV.
- The section which triggered the protection switches between all MOSFETs OFF and all low-sides ON in order to follow the voltage imposed by the DVID\_Fast on-going. This limits the output voltage excursion, protects the load and assures no undershoot is generated (if  $V_{OUT} < 250$  mV, the section is HiZ).
- The non-involved section turns off all the MOSFETs in order to realize a HiZ condition. Only if the non-involved section runs in Jmode does the rail keep switching.
- xOSC/ FLT pin of the OVP involved section is driven high.

If the cause of the failure is removed, the converter ends the transition with all PWMs in HiZ state and the output voltage of the section which triggered the protection lower than 250 mV.

The enable or VCC cycle (VCC5 or VCC12) can restart the system but the enable cycle does not discharge the SMBus embedded register, in this case, a VCC cycle is necessary to restart the system with default value.

## 9.2 Overcurrent

The overcurrent threshold can be programmed to a safe value to avoid the system not entering OC during normal operation of the device. This value must take into consideration also the extra current needed during the DVID transition ( $I_{DVID}$ ) and the process spread and temperature variations of the sensing elements (inductor DCR). Two OCP types (for average and for phase) can be detected on each rail.

### 9.2.1 Multi-phase section

The L6718 performs two different OC protections for the multi-phase section: it monitors both the total current and the per-phase current and allows the setting of an OC threshold for both.

- Phase OC. Maximum information current phase ( $I_{INFOx}$ ) is internally limited to 35  $\mu$ A. This end-of-scale current ( $I_{OC\_TH}$ ) is compared with the information current generated for each phase ( $I_{INFOx}$ ). If the current information for the single-phase exceeds the end-of-scale current (i.e. if  $I_{INFOx} > I_{OC\_TH}$ ), the device turns on the LS MOSFET until the threshold is re-crossed (i.e. until  $I_{INFOx} < I_{OC\_TH}$ ). Skipping cycle, latch condition occurs when UVP is reached.
- Total current OC. The IMON pin allows a maximum total output current for the system ( $I_{OC\_TOT}$ ) to be defined. The total sum  $I_{MON}$  of the current read on each phase ( $I_{INFOx}$ ) is sourced from the IMON pin. By connecting a resistor  $R_{IMON}$  to SGND, a load indicator with  $V_{OC\_TOT}$  end-of-scale can be implemented. When the voltage present at the IMON pin crosses  $V_{OC\_TOT}$ , the device detects an OC and immediately latches with all the MOSFETs of all the sections OFF (HiZ).  $V_{OC\_TOT}$  can be selected through SMBus dynamically or using CONFIG2 as pinstrapping. It is possible to choose:
  - a) OCP=125% of IMAX, so  $V_{OC\_TOT} = 1.55$  V
  - b) OCP=137% of IMAX, so  $V_{OC\_TOT} = 1.7$  V (default)



A typical design considers the intervention of the total current OC before the per-phase OC, leaving the latter as an extreme-protection in case of hardware failure in the external components. Total current OC depends on the  $I_{MON}$  design and on the application TDC and max. current supported. A typical design flow is the following:

- Define the maximum total output current ( $I_{OC\_TOT}$ ) according to system requirements ( $I_{MAX}$ ,  $I_{TDC}$ ). Considering  $I_{MON}$  design,  $I_{MAX}$  must correspond to 1.24 V (for correct  $I_{MAX}$  detection) so  $I_{OC\_TOT}$  results defined, as a consequence:

#### Equation 10

$$I_{OC\_TOT} = I_{MAX} \cdot V_{OC\_TOT} / 1.24$$

- Design per-phase OC and  $R_G$  resistor in order to have  $I_{INFOX} = I_{OC\_TH}$  (35  $\mu$ A) when  $I_{OUT}$  is over the OCP in a worst-case condition considering the ripple current and the extra current related to the DVID transient  $I_{DVID}$ . Usually it is 10% higher than the  $I_{OC\_TOT}$  current:

#### Equation 11

$$R_G = \frac{(1.1 \cdot I_{OC\_TOT}) \cdot DCR}{N \cdot I_{OCTH}}$$

where N is the number of phases and DCR the DC resistance of the inductors.  $R_G$  should be designed in worst-case conditions.

- Design the total current OC and  $R_{IMON}$  in order to have the IMON pin voltage at 1.24 V at the  $I_{MAX}$  current specified by the design. It results:

#### Equation 12

$$R_{IMON} = \frac{1.24V \cdot R_G}{I_{MAX} \cdot DCR} \left( I_{MON} = \frac{DCR}{R_G} \cdot I_{OUT} \right)$$

where  $I_{MAX}$  is max. current requested by the processor.

- Adjust the defined values according to the bench-test of the application.
- $C_{IMON}$  in parallel to  $R_{IMON}$  can be added with proper time constant to prevent false OC tripping.

*Note:* This is a typical design flow. Custom design and specifications may require different settings and ratios between the per-phase OC threshold and the total OC threshold. Applications with big ripple across inductors may be required to set per-phase OC to values different than 110%: design flow should be modified accordingly.

### 9.2.2 Overcurrent and power states

When the controller receives a set PS command through the SVI interface or automatic DPM is set, the L6718 changes the number of working phases. In particular, the maximum number of phases which the L6718 may work in >PS1 is limited to 2 phases regardless of the number N configured in PS0. The OC level is then scaled as the controller enters >PS0, as per [Table 19](#).

Table 19. Multi-phase section OC scaling and power states

N (active phases in PS0)	OC level in PS0	OC level in PS1, PS2
4	1.550 V / 1.700 V	0.800 V / 0.900 V
3		1.050 V / 1.150 V
2		1.550 V / 1.700 V

### 9.2.3 Single-phase section

The single-phase section features the same protection for phase and for average, as per multi-phase section. All the previous relationships remain applicable upon updating variables, referencing them to the single-phase section and considering this is working in single-phase.

## 10 Single NTC thermal monitor and compensation

The L6718 features single NTC for thermal sensing for both thermal monitoring and compensation. The thermal monitor consists in monitoring the converter temperature, eventually reporting an alarm by asserting the VR\_HOT signal. This is the base for the temperature zone register fill. Thermal compensation consists of compensating the inductor DCR derating with temperature and so preventing drifts in any variable correlated to the DCR: voltage positioning, overcurrent, IMON, current reporting. Both functions share the same thermal sensor (NTC) to optimize the overall application cost without compromising performance.

TM and TCOMP are pins used for the multi-rail thermal compensation and monitoring while STM and STCOMP are used for single-rail, as a consequence every consideration for TM and TCOMP in [Section 10.2](#) and [Section 10.3](#) can be used for STM and STCOMP for the single-rail.

### 10.1 Thermal monitor and VR\_HOT

The diagram for the thermal monitor is shown in [Figure 13](#). NTC should be placed close to the power stage hot-spot in order to sense the regulator temperature. As the temperature of the power stage increases, the NTC resistive value decreases, therefore reducing the voltage observable at the TM pin.

Recommended NTC is NTHS0805N02N6801 (or equivalent with  $\beta_{25/75} = 3500 \pm 10\%$ ) for accurate temperature sensing and thermal compensation. Different NTC may be used: to reach the required accuracy in temperature reporting, a proper resistive network must be used in order to match the resulting characteristics with those coming from the recommended NTC.

The voltage observed at the TM pin is internally converted and then used to fill in the temperature zone register. When the temperature observed exceeds TMAX (programmed via pinstrapping), the L6718 asserts VR\_HOT (active low - as long as the overtemperature event lasts) and the ALERT# line (until reset by the GetReg command on the status register).

**Figure 13. Thermal monitor connections**

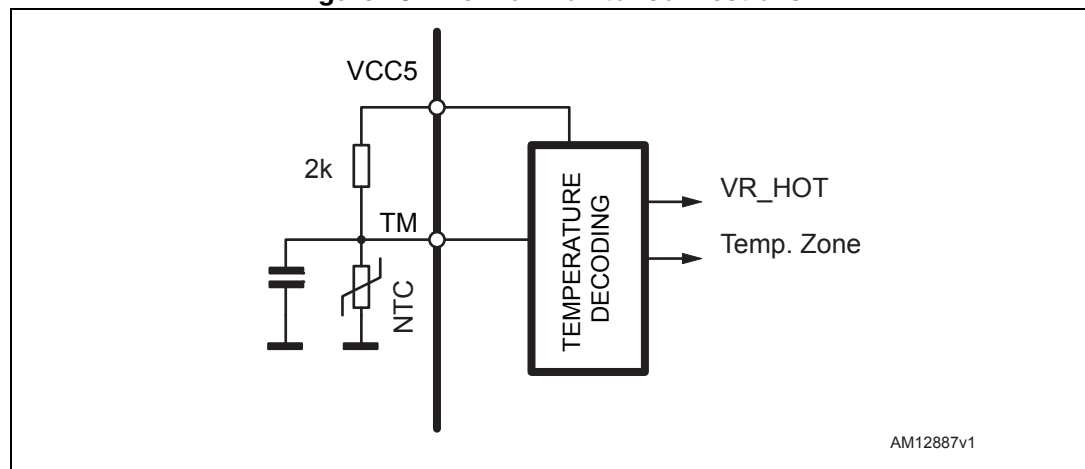

## 10.2 Thermal compensation

The L6718 supports DCR sensing for output voltage positioning: the same current information used for voltage positioning is used to define the overcurrent protection and the current reporting (register 15h in SVI). Having imprecise and temperature-dependant information leads to a violation of the specifications and misleading information returned to the SVI master: positive thermal coefficient specific from DCR must be compensated to get stable behavior of the converter as the temperature increases. Un-compensated systems show temperature dependencies on the regulated voltage, overcurrent protection and current reporting (Reg 15h).

The temperature information available on the TM pin and used for the thermal monitor may also be used for this purpose. In single NTC thermal compensation, the L6718 corrects the  $I_{\text{DROOP}}$  and  $I_{\text{MON}}$  current by comparing the voltage on the TM pin with the voltage present on the TCOMP pin and recovering the DCR temperature deviation. Depending on the NTC location and distance from the inductors and the available airflow, the correlation between NTC temperature and DCR temperature may be different: TCOMP adjustments allow the gain between the sensed temperature and the correction made on the  $I_{\text{DROOP}}$  and  $I_{\text{MON}}$  currents to be modified.

Shorting TCOMP to GND disables single NTC thermal compensation on the multi-phase rail. In this case  $I_{\text{DROOP}}$  and  $I_{\text{MON}}$  can be still adjusted by adding one NTC on the compensation network for  $I_{\text{DROOP}}$  and another NTC for the current monitoring network for  $I_{\text{MON}}$ . Both NTCs must be positioned close to the inductor related to Phase1 as it is the only phase working in all PS status.

If STCOMP/DDR is short to GND, the DDR mode is selected and the single NTC thermal compensation is disabled on the single-phase rail. In this case the two currents can be adjusted by adding an NTC close to the inductor on the compensation network for  $I_{\text{DROOP}}$  and the current monitoring network for  $I_{\text{MON}}$ .

## 10.3 TM and TCOMP design

This procedure applies to both the single-phase and multi-phase section when using single NTC thermal compensation:

1. Properly choose the resistive network to be connected to the TM pin. The recommended values/network is given in [Figure 13](#).
2. Connect the voltage generator to the TCOMP pin (default value 3.3 V).
3. Power on the converter and load the thermal design current (TDC) with the desired cooling conditions. Record the output voltage regulated as soon as the load is applied.
4. Wait for thermal steady-state. Adjust down the voltage generator on the TCOMP pin in order to get the same output voltage recorded at point #3.
5. Design the voltage divider connected to TCOMP (between VCC5 and GND) in order to get the same voltage set to TCOMP at point #4.
6. Repeat the test with the TCOMP divider designed at point #5 and verify the thermal drift is acceptable. In the case of positive drift (i.e. output voltage at thermal steady-state is bigger than the output voltage immediately after loading TDC current), change the divider at the TCOMP pin in order to reduce the TCOMP voltage. In the case of negative drift (i.e. output voltage at thermal steady-state is smaller than the output

voltage immediately after loading TDC current), change the divider at the TCOMP pin in order to increase the TCOMP voltage.

7. The same procedure can be implemented with a variable resistor in place of one of the resistors of the divider. In this case, once the compensated configuration is found, simply replace the variable resistor with a resistor of the same value.

## 11 Main oscillator

The internal oscillator generates the triangular waveform for the PWM charging and discharging with a constant current internal capacitor. The switching frequency for each channel,  $F_{SW}$ ,  $F_{SSW}$ , is internally fixed at 200 kHz: the resulting switching frequency at the load side for the multi-phase section results in being multiplied by N (number of configured phases).

The current delivered to the oscillator is typically 20  $\mu\text{A}$  (corresponding to the free-running frequency  $F_{SW} = 200 \text{ kHz}$ ) and it may be varied using an external resistor ( $R_{OSC}$ ,  $R_{SOSC}$ ) typically connected between the OSC, SOSC pins and GND. Since the OSC/SOSC pins are fixed at 1.8 V, the frequency is varied proportionally to the current sunk from the pin considering the internal gain of 10 kHz/ $\mu\text{A}$  (see [Figure 14](#)).

Connecting  $R_{OSC}$  to SGND, the frequency is increased (current is sunk from the pin), according to the following relationships:

### Equation 13

$$F_{SW} = 200\text{kHz} + \frac{1.800\text{V}}{R_{OSC}(\text{k}\Omega)} \cdot 10 \frac{\text{kHz}}{\mu\text{A}}$$

**Figure 14.  $R_{OSC}$  [KOhm] vs. switching frequency [kHz] per phase**

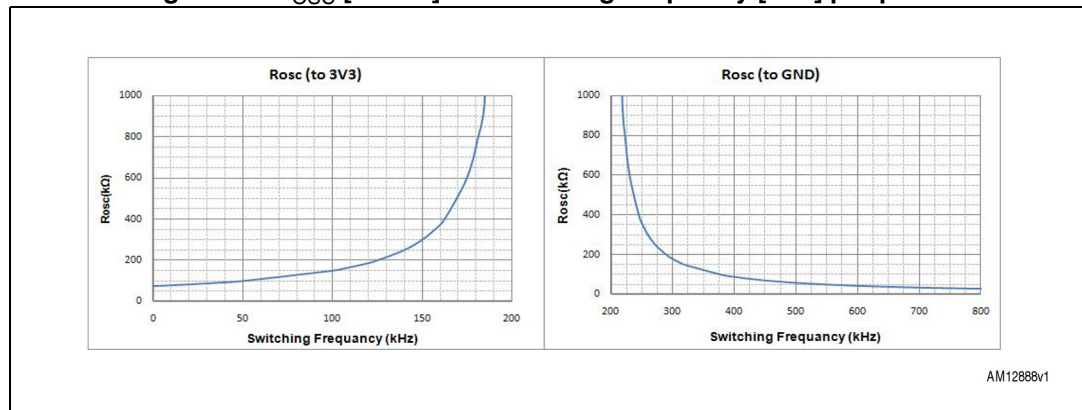

## 12 System control loop compensation

The multi-phase rail control system can be modeled with an equivalent single-phase rail converter with the only difference being the equivalent inductor  $L/N$  (where each phase has an  $L$  inductor and  $N$  is the number of the configured phases), see [Figure 15](#).

Figure 15. Equivalent control loop

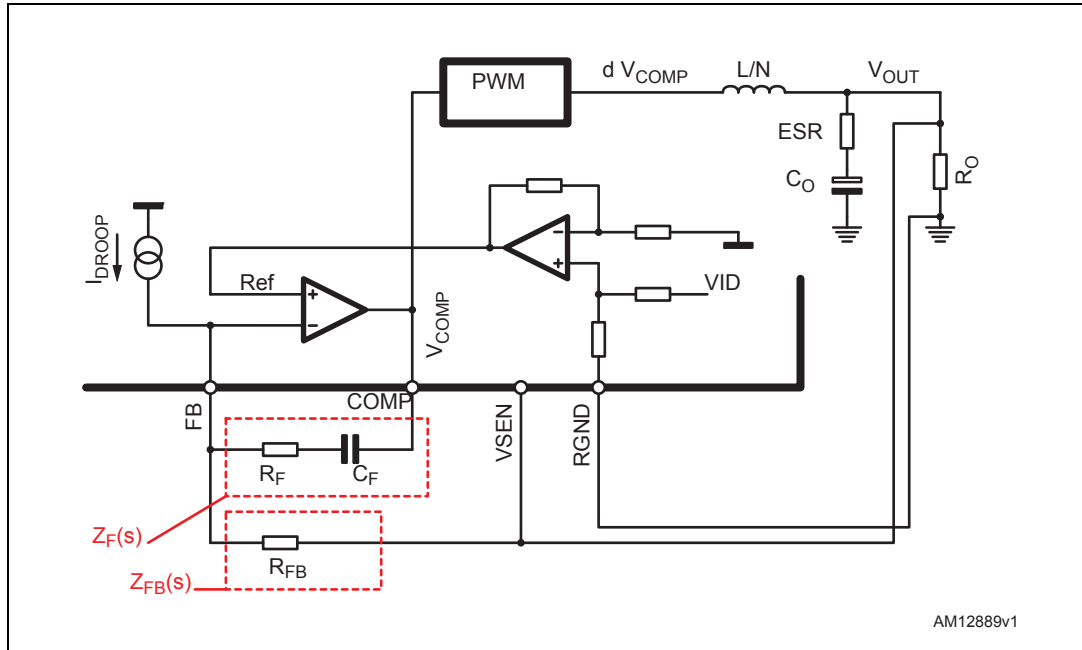

The control loop gain results (obtained opening the loop after the COMP pin):

### Equation 14

$$G_{LOOP}(s) = \frac{PWM \cdot Z_F(s) \cdot (R_{LL} + Z_P(s))}{[Z_P(s) + Z_L(s)] \cdot \left[ \frac{Z_F(s)}{A(s)} + \left(1 + \frac{1}{A(s)}\right) \cdot R_{FB} \right]}$$

where:

- $R_{LL}$  is the equivalent output resistance determined by the droop function (voltage positioning)
- $Z_P(s)$  is the impedance resulting from the parallel of the output capacitor (and its ESR) and the applied load  $R_O$
- $Z_F(s)$  is the compensation network impedance
- $Z_L(s)$  is the equivalent inductor impedance
- $A(s)$  is the error amplifier gain
- $PWM = \frac{9}{10} \cdot \frac{V_{IN}}{\Delta V_{OSC}}$  is the PWM transfer function.

The control loop gain is designed in order to obtain a high DC gain to minimize static error and to cross the 0dB axes with a constant -20 dB/dec slope with the desired crossover frequency  $\omega_T$ . Neglecting the effect of  $Z_F(s)$ , the transfer function has one zero and two

poles; both poles are fixed once the output filter is designed (LC filter resonance  $\omega_{LC}$ ) and the zero ( $\omega_{ESR}$ ) is fixed by ESR and the droop resistance.

**Figure 16. Control loop Bode diagram and fine tuning**

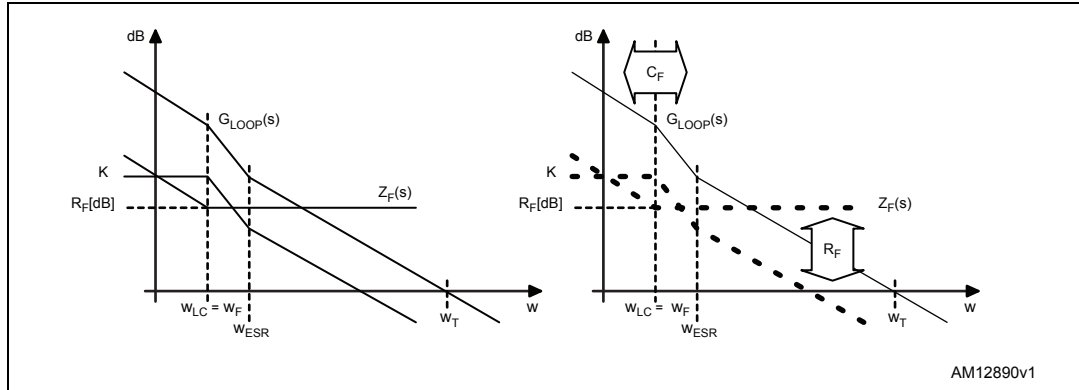

To obtain the desired shape, an  $R_F - C_F$  series network is considered for the  $Z_F(s)$  implementation. A zero at  $\omega_F = 1/R_F C_F$  is then introduced together with an integrator. This integrator minimizes the static error while placing the zero  $\omega_F$  in correspondence with the L-C resonance assures a simple -20 dB/dec shape of the gain.

In fact, considering the usual value for the output filter, the LC resonance results as a frequency lower than the above reported zero.

The compensation network can be designed as follows:

**Equation 15**

$$R_F = \frac{R_{FB} \cdot \Delta V_{OSC}}{V_{IN}} \cdot \frac{10}{9} \cdot \frac{F_{SW} \cdot L}{(R_{LL} + ESR)}$$

**Equation 16**

$$C_F = \frac{\sqrt{C_O \cdot L}}{R_F}$$

## 12.1 Compensation network guidelines

The compensation network design assures a system that responds according to the cross-over frequency selected and to the output filter considered: it is anyway possible to further fine-tune the compensation network modifying the bandwidth in order to get the best response of the system as follows (see [Figure 15](#)):

- Increase  $R_F$  to increase the system bandwidth accordingly.
- Decrease  $R_F$  to decrease the system bandwidth accordingly.
- Increase  $C_F$  to move  $\omega_F$  to low frequencies increasing as a consequence the system phase margin.

Even with fast compensation network design the load requirement can be limited by the inductor value because it limits the maximum  $dI/dt$  that the system can afford. In fact, when a load transient is applied, the best that the controller can do is to “saturate” the duty cycle to its maximum ( $d_{MAX}$ ) or minimum (0) value. The output voltage  $dV/dt$  is then limited by the inductor charge/discharge time and by the output capacitance. In particular, the most

limiting transition corresponds to the load-removal since the inductor results as being discharged only by  $V_{OUT}$  (while it is charged by  $V_{IN}-V_{OUT}$  during a load appliance).

*Note: The introduction of a capacitor ( $C_i$ ) in parallel to  $R_{FB}$  significantly speeds up the transient response by coupling the output voltage  $dV/dt$  on the FB pin, therefore using the error amplifier as a comparator. The COMP pin suddenly reacts and, also thanks to the LTB Technology control scheme, all the phases can be turned on together to immediately give the output the required energy. A typical design considers starting from values in the range of 100 pF, validating the effect through bench testing. An additional series resistor ( $R_i$ ) can also be used.*

## 12.2 LTB technology

LTB Technology further enhances the performances of the controller by reducing the system latencies and immediately turning ON all the phases to provide the correct amount of energy to the load optimizing the output capacitor count.

LTB Technology monitors the output voltage through a dedicated pin detecting load-transients with selected  $dV/dt$ , it cancels the interleaved phase-shift, turning on simultaneously all phases.

The LTB detector is able to detect output load transients by coupling the output voltage through an  $R_{LTB} - C_{LTB}$  network. After detecting a load transient, all the phases are turned on together and the EA latencies result as bypassed as well.

Sensitivity of the load transient detector can be programmed in order to control precisely both the undershoot and the ring-back.

*LTB Technology design tips.*

- Decrease  $R_{LTB}$  to increase the system sensitivity, making the system sensitive to smaller  $dV_{OUT}$ .
- Increase  $C_{LTB}$  to increase the system sensitivity, making the system sensitive to higher  $dV/dt$ .
- Increase  $R_i$  to increase the width of the LTB pulse.

Increase  $C_i$  to increase the LTB sensitivity over frequency.

Short LTB pin to GND to disable the function on multi-phase rail. Since LTB technology is embedded on single-phase rail, SVSEN pin needs to be filtered to disable this feature.



## 13 Power dissipation and application details

### 13.1 High-current embedded drivers

The L6718 integrates 3 high-current drivers in control which can work for multi-rail and single-rail. By reducing the number of external components, this integration optimizes the cost and space of the motherboard solution.

The driver for the high-side MOSFET uses the BOOTx pins for supply and the PHASEx pins for return. The driver for the low-side MOSFET uses the VCC12 pin for supply and the GND exposed pad for return.

The embedded driver embodies an anti-shoot-through and adaptive deadtime control to minimize low-side body diode conduction time maintaining good efficiency and saving the use of diodes: when the high-side MOSFET turns off, the voltage on its source begins to fall; when the voltage reaches about 2 V, the low-side MOSFET gate drive voltage is suddenly applied. When the low-side MOSFET turns off, the voltage at the LGATE pin is sensed. When it drops below about 1 V, the high-side MOSFET gate drive voltage is suddenly applied. If the current flowing in the inductor is negative, the source of the high-side MOSFET never drops. To allow the low-side MOSFET to turn on even in this case, a watchdog controller is enabled: if the source of the high-side MOSFET does not drop, the low-side MOSFET is switched on, therefore allowing the negative current of the inductor to recirculate. This allows the system to regulate even if the current is negative.

### 13.2 Boot diode and capacitor design

The bootstrap capacitor must be designed in order to show a negligible discharge due to the high-side MOSFET turn-on. In fact, it must give a stable voltage supply to the high-side driver during the MOSFET turn-on, also minimizing the power dissipated by the embedded boot diode.

To prevent the bootstrap capacitor from extra-charging as a consequence of large negative spikes, an external series resistance  $R_{BOOT}$  (in the range of few Ohm) may be required in series to the BOOTx pins.

One external Schottky boot diode must be added to each channel, between the high-side driver power supply and the BOOTx pins.

### 13.3 Device power dissipation

As the L6718 embeds three high-current MOSFET drivers for both high-side and low-side MOSFETs, it is important to consider the power the device is going to dissipate in driving them, in order to avoid the maximum junction operative temperature being exceeded.

The exposed pad (PGND pin) must be soldered to the PCB power ground plane through several VIAs in order to facilitate the heat dissipation.

Two main terms contribute to the device power dissipation: bias power and driver power.

- Device power ( $P_{DC}$ ) depends on the static consumption of the device through the supply pins and it is simply quantifiable as follows (assuming HS and LS drivers are supplied with the same VCC of the device):

**Equation 17**

$$P_{DC} = V_{CC} \cdot I_{CC} + V_{VCCDR} \cdot I_{VCCDR}$$

- Driver power is the power needed by the driver to continuously switch ON and OFF the external MOSFETs; it is a function of the switching frequency and total gate charge of the selected MOSFETs. It can be quantified considering that the total power  $P_{SW}$  dissipated to switch the MOSFETs is dissipated by three main factors: external gate resistance (when present), intrinsic MOSFET resistance and intrinsic driver resistance. This last term is the important one to be determined in order to calculate the device power dissipation.

The total power dissipated to switch the MOSFETs for each phase featuring an embedded driver results:

**Equation 18**

$$P_{SWx} = F_{SW} \cdot (Q_{GHSx} \cdot V_{VCCDR} + Q_{GLSx} \cdot V_{BOOTx})$$

where  $Q_{GHSx}$  is the total gate charge of the HS MOSFETs and  $Q_{GLSx}$  is the total gate charge of the LS MOSFETs for both CORE and NB sections (only Phase1 and Phase2 for CORE section);  $V_{BOOTx}$  is the driving voltage for the HSx MOSFETs.

External gate resistors help the device to dissipate the switching power as the same power ( $P_{SW}$ ) is shared between the internal driver impedance and the external resistor resulting in a general cooling of the device. When diving multiple MOSFETs in parallel, it is suggested to use one resistor on each MOSFET.

## 14 Layout guidelines

The layout is one of the most important factors to consider when designing high-current applications. A good layout solution can generate benefits by lowering power dissipation on the power paths; reducing radiation and a proper connection between signal and power ground can optimize the performance of the control loops.

Two kinds of critical components and connections must be considered when laying out a VRM based on the L6718: power components and connections and small signal component connections.

### 14.1 Power components and connections

These are the components and connections where switching and high continuous current flows from the input to the load. The first priority when placing components must be reserved for this power section, minimizing the length of each connection and loop as much as possible. To minimize noise and voltage spikes (EMI and losses) these interconnections must be part of a power plane and realized by wide and thick copper traces: loop must be minimized. The critical components, i.e. the power transistors, must be close to one another. The use of a multi-layer printed circuit board is recommended.

As the L6718 uses external drivers to switch the Power MOSFETs, check the selected driver documentation for information related to the proper layout for this part.

### 14.2 Small signal components and connections

These are small signal components and connections to critical nodes of the application as well as bypass capacitors for the device supply. Locate the bypass capacitor close to the device and refer sensitive components such as the frequency set-up resistor  $R_{OSC}$  (both sections). The VSEN and SVSEN pins filtered vs. GND helps to reduce noise injection into the device and the ENABLE pin filtered vs. GND helps to reduce false tripping due to coupled noise: take care when routing the driving net for this pin in order to minimize coupled noise.

Remote buffer connection must be routed as parallel nets from the VSEN/FBG and SVSEN/SFBG pins to the load in order to avoid the pick-up of any common mode noise. Connecting these pins in points far from the load causes a non-optimum load regulation, increasing output tolerance.

Locate current reading components close to the device. The PCB traces connecting the reading points must use dedicated nets, routed as parallel traces in order to avoid the pick-up of any common mode noise. It's also important to avoid any offset in the measurement and, to get a better precision, to connect the traces as close as possible to the sensing elements. Symmetrical layout is also suggested. A small filtering capacitor can be added, near the controller, between  $V_{OUT}$  and GND, on the CSx-line when reading across the inductor to allow higher layout flexibility.

## 15 Package mechanical data

In order to meet environmental requirements, ST offers these devices in different grades of ECOPACK<sup>®</sup> packages, depending on their level of environmental compliance. ECOPACK<sup>®</sup> specifications, grade definitions and product status are available at: [www.st.com](http://www.st.com). ECOPACK<sup>®</sup> is an ST trademark.

**Table 20. VFQFPN56 7x7 mm mechanical data**

Dim.	mm		
	Min.	Typ.	Max.
A	0.80	0.90	1.00
A1	0	0.02	0.05
D	6.90	7.00	7.10
D2	5.05	5.20	5.30
E	6.90	7.00	7.10
E2	5.05	5.20	5.30
b	0.15	0.20	0.25
e		0.40	
k	0.20		
L	0.40	0.50	0.60
aaa		0.10	
bbb		0.10	
ccc		0.10	

Figure 17. VFQFPN56 7x7 mm package dimensions

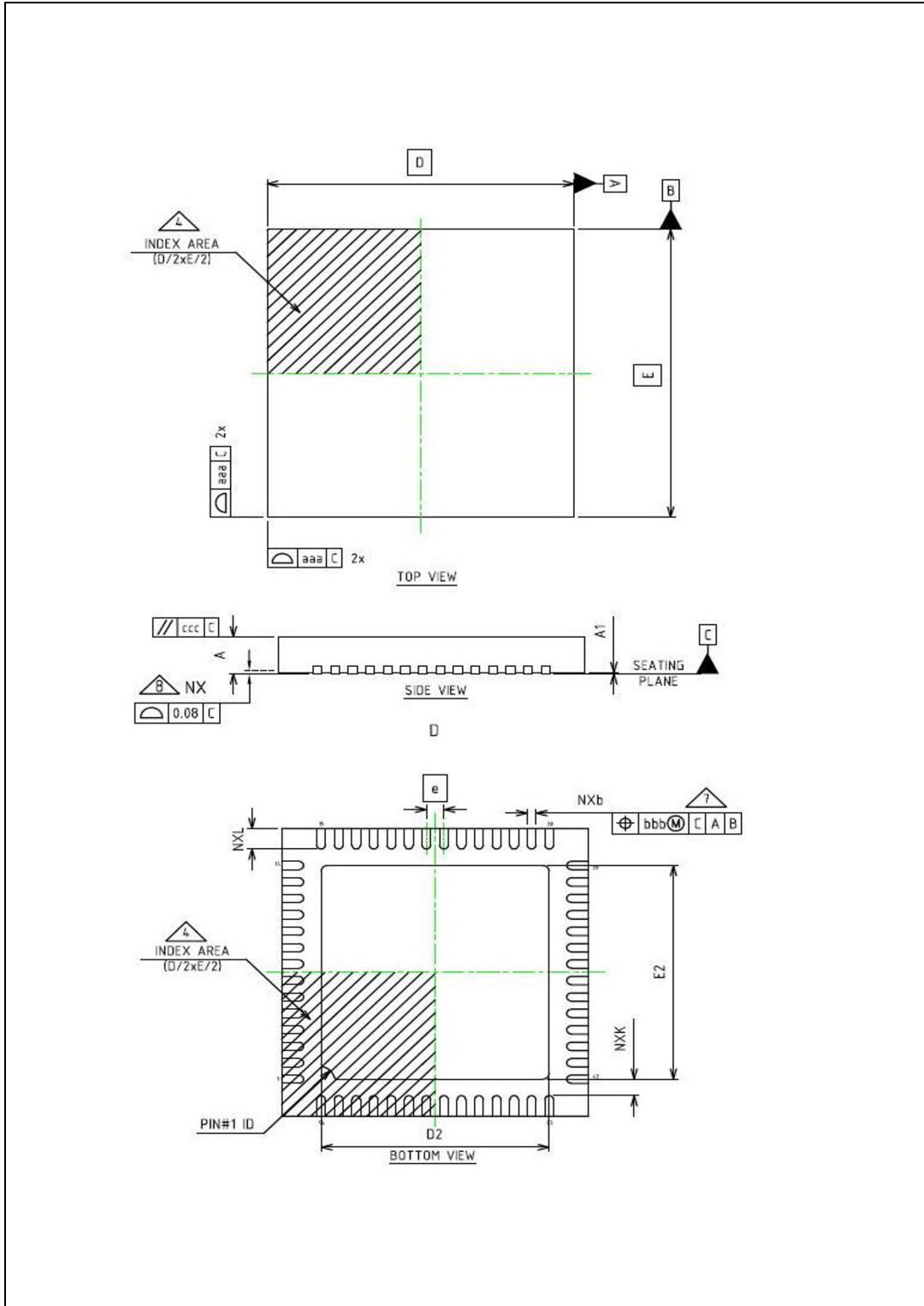

## 16 Revision history

**Table 21. Document revision history**

Date	Revision	Changes
19-Jul-2012	1	Initial release.
08-Nov-2012	2	Minor text changes. Updated the value of the parameter BOOTx in <a href="#">Table 4</a> . Updated <a href="#">Section 13.2</a> .
19-Apr-2013	3	Changed $R_{th(JA)}$ , $T_J$ and $P_{tot}$ values in <a href="#">Table 3</a> . Added $t_{RISE\_UGATE}$ and $t_{RISE\_LGATE}$ values to <a href="#">Table 5</a> . Updated <a href="#">Table 20: VFQFPN56 7x7 mm mechanical data</a> .

**Please Read Carefully:**

Information in this document is provided solely in connection with ST products. STMicroelectronics NV and its subsidiaries ("ST") reserve the right to make changes, corrections, modifications or improvements, to this document, and the products and services described herein at any time, without notice.

All ST products are sold pursuant to ST's terms and conditions of sale.

Purchasers are solely responsible for the choice, selection and use of the ST products and services described herein, and ST assumes no liability whatsoever relating to the choice, selection or use of the ST products and services described herein.

No license, express or implied, by estoppel or otherwise, to any intellectual property rights is granted under this document. If any part of this document refers to any third party products or services it shall not be deemed a license grant by ST for the use of such third party products or services, or any intellectual property contained therein or considered as a warranty covering the use in any manner whatsoever of such third party products or services or any intellectual property contained therein.

**UNLESS OTHERWISE SET FORTH IN ST'S TERMS AND CONDITIONS OF SALE ST DISCLAIMS ANY EXPRESS OR IMPLIED WARRANTY WITH RESPECT TO THE USE AND/OR SALE OF ST PRODUCTS INCLUDING WITHOUT LIMITATION IMPLIED WARRANTIES OF MERCHANTABILITY, FITNESS FOR A PARTICULAR PURPOSE (AND THEIR EQUIVALENTS UNDER THE LAWS OF ANY JURISDICTION), OR INFRINGEMENT OF ANY PATENT, COPYRIGHT OR OTHER INTELLECTUAL PROPERTY RIGHT.**

**ST PRODUCTS ARE NOT AUTHORIZED FOR USE IN WEAPONS. NOR ARE ST PRODUCTS DESIGNED OR AUTHORIZED FOR USE IN: (A) SAFETY CRITICAL APPLICATIONS SUCH AS LIFE SUPPORTING, ACTIVE IMPLANTED DEVICES OR SYSTEMS WITH PRODUCT FUNCTIONAL SAFETY REQUIREMENTS; (B) AERONAUTIC APPLICATIONS; (C) AUTOMOTIVE APPLICATIONS OR ENVIRONMENTS, AND/OR (D) AEROSPACE APPLICATIONS OR ENVIRONMENTS. WHERE ST PRODUCTS ARE NOT DESIGNED FOR SUCH USE, THE PURCHASER SHALL USE PRODUCTS AT PURCHASER'S SOLE RISK, EVEN IF ST HAS BEEN INFORMED IN WRITING OF SUCH USAGE, UNLESS A PRODUCT IS EXPRESSLY DESIGNATED BY ST AS BEING INTENDED FOR "AUTOMOTIVE, AUTOMOTIVE SAFETY OR MEDICAL" INDUSTRY DOMAINS ACCORDING TO ST PRODUCT DESIGN SPECIFICATIONS. PRODUCTS FORMALLY ESCC, QML OR JAN QUALIFIED ARE DEEMED SUITABLE FOR USE IN AEROSPACE BY THE CORRESPONDING GOVERNMENTAL AGENCY.**

Resale of ST products with provisions different from the statements and/or technical features set forth in this document shall immediately void any warranty granted by ST for the ST product or service described herein and shall not create or extend in any manner whatsoever, any liability of ST.

ST and the ST logo are trademarks or registered trademarks of ST in various countries.

Information in this document supersedes and replaces all information previously supplied.

The ST logo is a registered trademark of STMicroelectronics. All other names are the property of their respective owners.

© 2013 STMicroelectronics - All rights reserved

STMicroelectronics group of companies

Australia - Belgium - Brazil - Canada - China - Czech Republic - Finland - France - Germany - Hong Kong - India - Israel - Italy - Japan - Malaysia - Malta - Morocco - Philippines - Singapore - Spain - Sweden - Switzerland - United Kingdom - United States of America

[www.st.com](http://www.st.com)

