

### Features

- Ultra low power dissipation:  
 $I_{CC} = 0.2 \mu\text{A}$  (max.) at  $T_A = 85^\circ\text{C}$
- Low ON resistance:
  - $R_{ON} = 0.50 \Omega$  (max.  $T_A = 25^\circ\text{C}$ ) at  $V_{CC} = 4.3 \text{ V}$
  - $R_{ON} = 0.55 \Omega$  (max.  $T_A = 25^\circ\text{C}$ ) at  $V_{CC} = 3.6 \text{ V}$
  - $R_{ON} = 0.55 \Omega$  (max.  $T_A = 25^\circ\text{C}$ ) at  $V_{CC} = 3.0 \text{ V}$
- Wide operating voltage range:  
 $V_{CC} (\text{opr}) = 1.65 \text{ V to } 4.3 \text{ V}$  single supply
- 5 V tolerant and 1.8 V compatible threshold on digital control input at  $V_{CC} = 1.65 \text{ to } 4.3 \text{ V}$
- Latch-up performance exceeds 300 mA (JESD 17)
- ESD performance:  
 $\text{HBM} > 2 \text{ kV}$  (MIL STD 883 method 3015)

### Description

The STG5223 is a high-speed CMOS dual analog SPDT (single pole dual throw) switch or dual 2:1 multiplexer/demultiplexer bus switch fabricated in silicon gate C<sup>2</sup>MOS technology. It is designed to operate from 1.65 to 4.3 V, making this device ideal for portable applications.

It offers very low ON resistance (<0.5  $\Omega$ ) at  $V_{CC} = 3.0 \text{ V}$ . The nIN inputs are provided to control the switches. The switches nS1 are ON (connected to common ports Dn) when the nIN input is held high and OFF (high impedance state

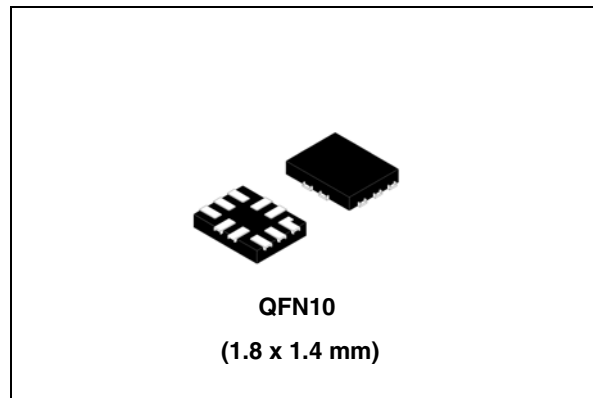

exists between the two ports) when nIN is held low. The switches nS2 are ON (connected to common ports Dn) when the nIN input is held low and OFF (high impedance state exists between the two ports) when IN is held high. Additional key features are fast switching speed, break-before-make delay time and ultra low power consumption. All inputs and outputs are equipped with protection circuits against static discharge, giving them ESD immunity and transient excess voltage immunity.

**Table 1. Device summary**

Order code	Package	Packaging
STG5223QTR	QFN10 (1.8 x 1.4 mm)	Tape and reel

---

# Contents

<b>1</b>	<b>Pin settings</b> .....	<b>3</b>
1.1	Pin connection .....	3
1.2	Pin description .....	3
<b>2</b>	<b>Input equivalent circuit and truth table</b> .....	<b>4</b>
<b>3</b>	<b>Maximum rating</b> .....	<b>5</b>
3.1	Recommended operating conditions .....	6
<b>4</b>	<b>Electrical characteristics</b> .....	<b>7</b>
<b>5</b>	<b>Test circuit</b> .....	<b>10</b>
<b>6</b>	<b>Package mechanical data</b> .....	<b>14</b>
<b>7</b>	<b>Revision history</b> .....	<b>18</b>

# 1 Pin settings

## 1.1 Pin connection

Figure 1. Pin connection (top through view)

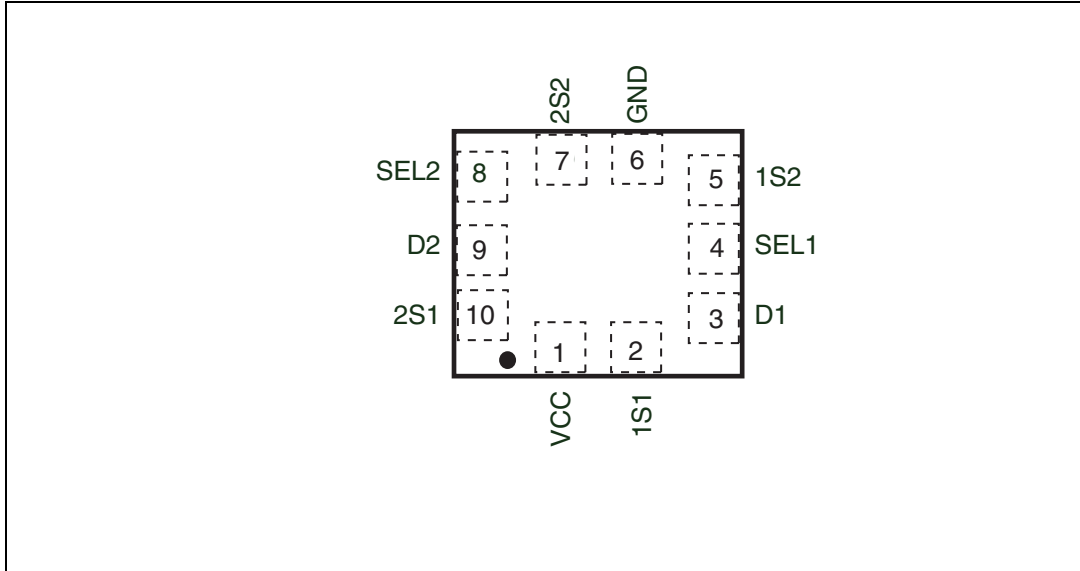

## 1.2 Pin description

Table 2. Pin description

Pin number	Symbol	Name and function
1	V <sub>CC</sub>	Positive supply voltage
2	1S1	Independent channel
3	D1	Common channel
4	SEL1	Control
5	1S2	Independent channel
6	GND	Ground (0V)
7	2S2	Independent channel
8	SEL2	Control
9	D2	Common channel
10	2S1	Independent channel

**Warning:** Exposed pad must be soldered to a floating plane. Do NOT connect to power or ground.

## 2 Input equivalent circuit and truth table

Figure 2. Input equivalent circuit

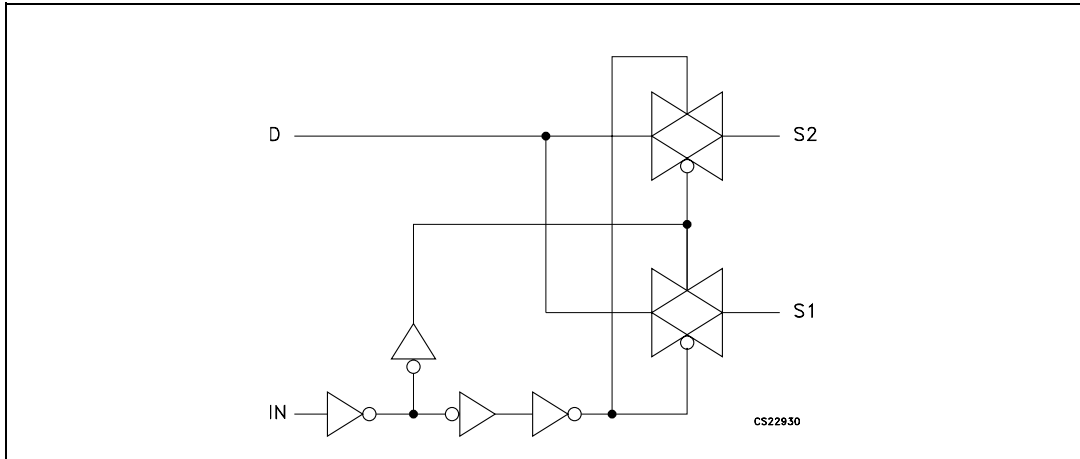

Table 3. Truth table

IN	Switch S1	Switch S2
H	ON	OFF <sup>(1)</sup>
L	OFF <sup>(1)</sup>	ON

1. High impedance

### 3 Maximum rating

Stressing the device above the rating listed in the “Absolute maximum ratings” table may cause permanent damage to the device. These are stress ratings only and operation of the device at these or any other conditions above those indicated in the operating sections of this specification is not implied. Exposure to absolute maximum rating conditions for extended periods may affect device reliability.

**Table 4. Absolute maximum ratings**

Symbol	Parameter	Value	Unit
$V_{CC}$	Supply voltage	-0.5 to 5.5	V
$V_I$	DC input voltage	-0.5 to $V_{CC} + 0.5$	V
$V_{IC}$	DC control input voltage	-0.5 to 5.5	V
$V_O$	DC output voltage	-0.5 to $V_{CC} + 0.5$	V
$I_{IKC}$	DC input diode current on control pin ( $V_{SEL} < 0$ V)	-50	mA
$I_{IK}$	DC input diode current ( $V_{IN} < 0$ V)	$\pm 50$	mA
$I_{OK}$	DC output diode current	$\pm 20$	mA
$I_O$	DC output current	$\pm 300$	mA
$I_{OP}$	DC output current peak (pulse at 1 ms, 10% duty cycle)	$\pm 500$	mA
$I_{CC}$ or $I_{GND}$	DC $V_{CC}$ or ground current	$\pm 100$	mA
$P_D$	Power dissipation at $T_A=70$ °C <sup>(1)</sup>	1120	mW
$T_{STG}$	Storage temperature	-65 to 150	°C
$T_L$	Lead temperature (10 sec)	300	°C

1. Derate above 70 °C by 18.5 mW/ °C

### 3.1 Recommended operating conditions

**Table 5. Recommended operating conditions**

Symbol	Parameter		Value	Unit
$V_{CC}$	Supply voltage		1.65 to 4.3	V
$V_I$	Input voltage		0 to $V_{CC}$	V
$V_{IC}$	Control input voltage		0 to 4.3	V
$V_O$	Output voltage		0 to $V_{CC}$	V
$T_{op}$	Operating temperature		-40 to 85	°C
dt/dv	Input rise and fall time control input	$V_{CC} = 1.65\text{ V to }2.7\text{ V}$	0 to 20	ns/V
		$V_{CC} = 3.0\text{ V to }4.3\text{ V}$	0 to 10	

## 4 Electrical characteristics

Table 6. DC specifications

Symbol	Parameter	V <sub>CC</sub> (V)	Test condition	Value					Unit
				T <sub>A</sub> = 25 °C			-40 to 85 °C		
				Min	Typ	Max	Min	Max	
V <sub>IH</sub>	High level input voltage	1.65 –1.95		0.65 V <sub>CC</sub>	–	–	0.65 V <sub>CC</sub>	–	V
		2.3 –2.5		1.2	–	–	1.2	–	
		2.7 –3.0		1.3	–	–	1.3	–	
		3.0 –3.6		1.4	–	–	1.4	–	
		4.3		1.5	–	–	1.5	–	
V <sub>IL</sub>	Low level input voltage	1.65 –1.95		–	–	0.25	–	0.25	V
		2.3 –2.5		–	–	0.25	–	0.25	
		2.7 –3.0		–	–	0.25	–	0.25	
		3.0 –3.6		–	–	0.30	–	0.30	
		4.3		–	–	0.40	–	0.40	
R <sub>ON</sub>	Switch ON resistance	4.3	V <sub>S</sub> = 0 V to V <sub>CC</sub> I <sub>S</sub> = 100 mA	–	0.45	0.50	–	0.55	Ω
		3.6		–	0.50	0.55	–	0.65	
		3.0		–	0.50	0.55	–	0.65	
		2.3		–	0.60	0.70	–	0.80	
		1.8		–	0.90	1.0	–	1.1	
ΔR <sub>ON</sub>	ON resistance match between channels <sup>(1)</sup>	2.3	V <sub>S</sub> = 0 V to V <sub>CC</sub> I <sub>S</sub> = 100 mA	–	0.1	–	–	–	Ω
R <sub>FLAT</sub>	ON resistance flatness <sup>(2)</sup>	4.3	V <sub>S</sub> = 0 V to V <sub>CC</sub> I <sub>S</sub> = 100 mA	–	0.15	0.20	–	0.20	Ω
		3.6			0.15	0.20	–	0.20	
		3.0			0.15	0.20	–	0.20	
		2.3			0.20	0.25	–	0.25	
		1.8			0.35	0.45	–	0.45	
I <sub>OFF</sub>	OFF state leakage current (nSn), (Dn)	4.3	V <sub>S</sub> = 0.3 or 4 V	–	–	±20	–	±100	nA
I <sub>IN</sub>	Input leakage current	0 –4.3	V <sub>SEL</sub> = 0 to 4.3 V	–	–	±0.05	–	±1	μA
I <sub>CC</sub>	Quiescent supply current	1.65 –4.3	V <sub>SEL</sub> = V <sub>CC</sub> or GND	–	–	±0.05	–	±0.2	μA

**Table 6. DC specifications (continued)**

Symbol	Parameter	V <sub>CC</sub> (V)	Test condition	Value					Unit
				T <sub>A</sub> = 25 °C			-40 to 85 °C		
				Min	Typ	Max	Min	Max	
I <sub>CCLV</sub>	Quiescent supply current low voltage driving	4.3	V <sub>1IN</sub> , V <sub>2IN</sub> = 1.65 V	–	±37	±50	–	±100	μA
			V <sub>1IN</sub> , V <sub>2IN</sub> = 1.80 V	–	±33	±40	–	±50	
			V <sub>1IN</sub> , V <sub>2IN</sub> = 2.60 V	–	±12	±20	–	±30	

1.  $\Delta R_{ON} = R_{ON(max)} - R_{ON(min)}$ .
2. Flatness is defined as the difference between the maximum and minimum value of on-resistance as measured over the specified analog signal ranges.

**Table 7. AC electrical characteristics (C<sub>L</sub> = 35 pF, R<sub>L</sub> = 50 Ω, t<sub>r</sub> = t<sub>f</sub> ≤ 5 ns)**

Symbol	Parameter	V <sub>CC</sub> (V)	Test condition	Value					Unit
				T <sub>A</sub> = 25 °C			-40 to 85 °C		
				Min	Typ	Max	Min	Max	
t <sub>PLH</sub> , t <sub>PHL</sub>	Propagation delay	1.65 – 1.95		–	0.30	–	–	–	ns
		2.3 – 2.7		–	0.25	–	–		
		3.0 – 3.3		–	0.20	–	–		
		3.6 – 4.3		–	0.20	–	–		
t <sub>ON</sub>	Turn-ON time	1.65 – 1.95	V <sub>S</sub> = 0.8 V	–	120	–	–	–	ns
		2.3 – 2.7	V <sub>S</sub> = 1.5 V	–	65	85	–	90	
		3.0 – 3.3		–	42	55	–	65	
		3.6 – 4.3		–	40	55	–	65	
t <sub>OFF</sub>	Turn-OFF time	1.65 – 1.95	V <sub>S</sub> = 0.8 V	–	45	–	–	–	ns
		2.3 – 2.7	V <sub>S</sub> = 1.5 V	–	18	30	–	40	
		3.0 – 3.3		–	16	30	–	40	
		3.6 – 4.3		–	15	30	–	40	
t <sub>D</sub>	Break-before- make time delay	1.65 – 1.95	C <sub>L</sub> = 35 pF R <sub>L</sub> = 50 Ω V <sub>S</sub> = 1.5 V	2	17	–	–	–	ns
		2.3 – 2.7		2	10	–	–	–	
		3.0 – 3.3		2	8	–	–	–	
		3.6 – 4.3		2	7	–	–	–	
Q	Charge injection	1.65 – 1.95	C <sub>L</sub> = 100 pF R <sub>L</sub> = 1 MΩ V <sub>GEN</sub> = 0 V R <sub>GEN</sub> = 0 Ω	–	43	–	–	–	pC
		2.3 – 2.7		–	51	–	–	–	
		3.0 – 3.3		–	51	–	–	–	
		3.6 – 4.3		–	49	–	–	–	



Table 8. Analog switch characteristics ( $C_L = 5 \text{ pF}$ ,  $R_L = 50 \text{ } \Omega$ ,  $T_A = 25 \text{ } ^\circ\text{C}$ )

Symbol	Parameter	$V_{CC}$ (V)	Test condition	Value					Unit
				$T_A = 25 \text{ } ^\circ\text{C}$			$-40 \text{ to } 85 \text{ } ^\circ\text{C}$		
				Min	Typ	Max	Min	Max	
OIRR	Off isolation <sup>(1)</sup>	1.65 –4.3	$V_S = 1 V_{RMS}$ $f = 100 \text{ kHz}$	–	-66	–	–	–	dB
Xtalk	Crosstalk	1.65 –4.3	$V_S = 1 V_{RMS}$ $f = 100 \text{ kHz}$	–	-72	–	–	–	dB
THD	Total harmonic distortion	2.3 –4.3	$R_L = 600 \text{ } \Omega$ $V_{SEL} = 2 V_{PP}$ $f = 20 \text{ Hz to } 20 \text{ kHz}$	–	0.02	–	–	–	%
BW	-3dB bandwidth	1.65 –4.3	$R_L = 50 \text{ } \Omega$	–	55	–	–	–	MHz
$C_{IN}$	Control pin input capacitance			–	7	–	–	–	pF
$C_{ON}$	Sn port capacitance when switch is enabled	3.3	$f = 1 \text{ MHz}$	–	114	–	–	–	
$C_{OFF}$	Sn port capacitance when switch is disabled	3.3	$f = 1 \text{ MHz}$	–	40	–	–	–	
$C_D$	D port capacitance when the switch is enabled	3.3	$f = 1 \text{ MHz}$	–	114	–	–	–	

1. Off isolation =  $20 \text{ Log}_{10} (V_D/V_S)$ ,  $V_D$  = output.  $V_S$  = input at off switch

# 5 Test circuit

Figure 3. ON resistance

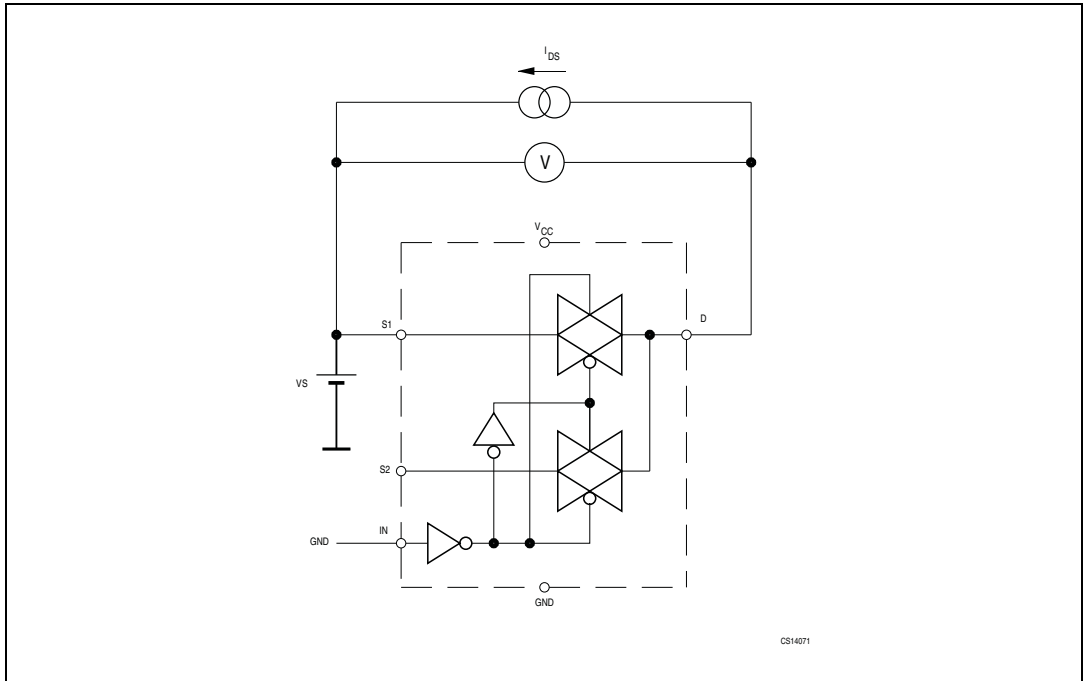

Figure 4. OFF leakage

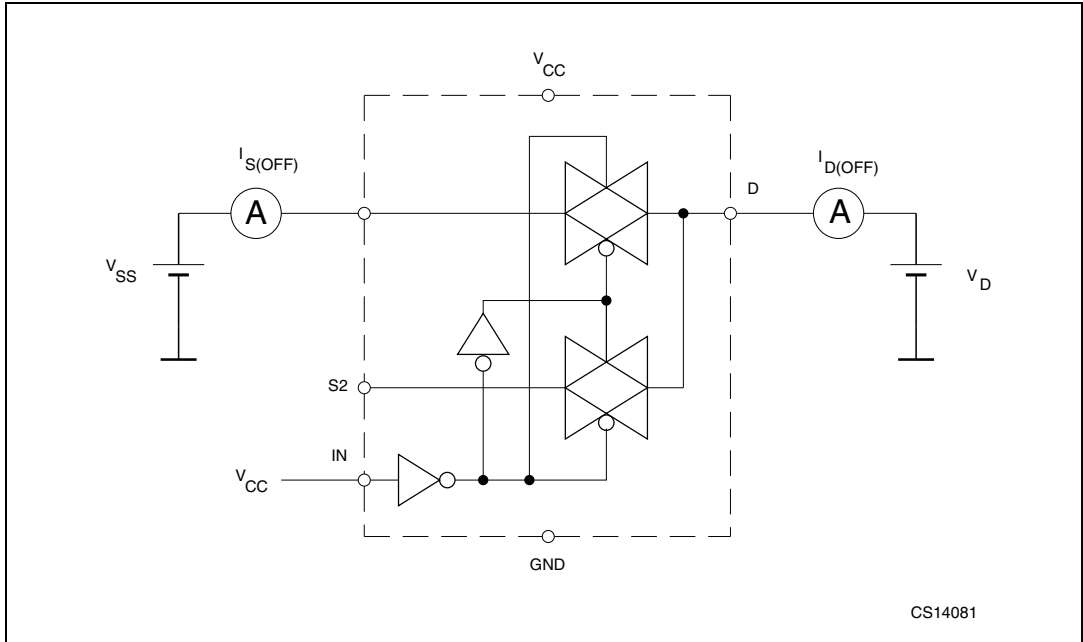

Figure 5. OFF isolation

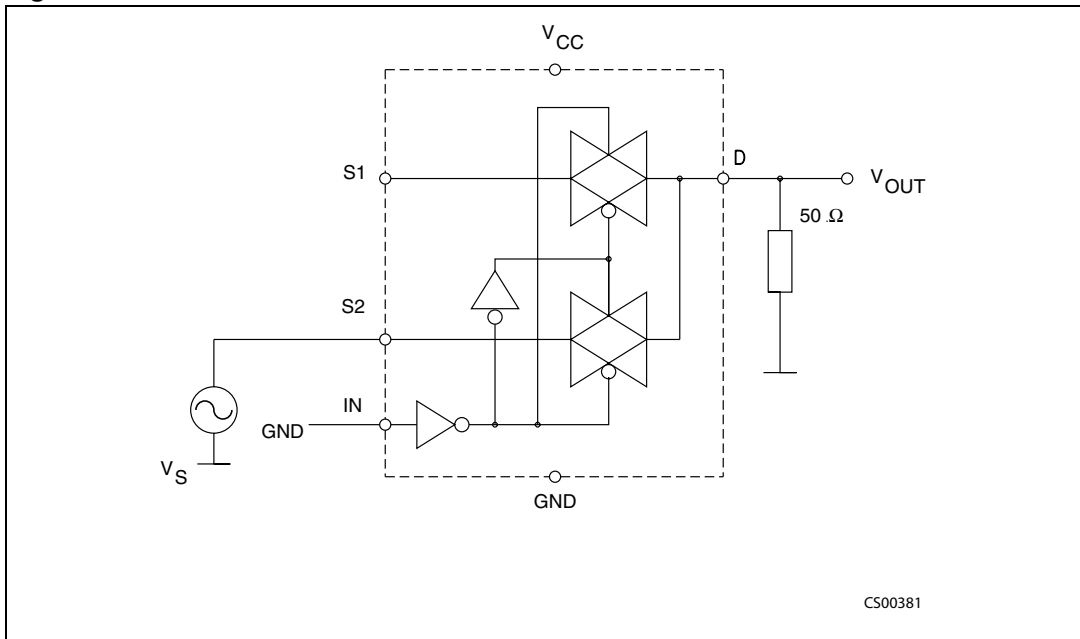

Figure 6. Bandwidth

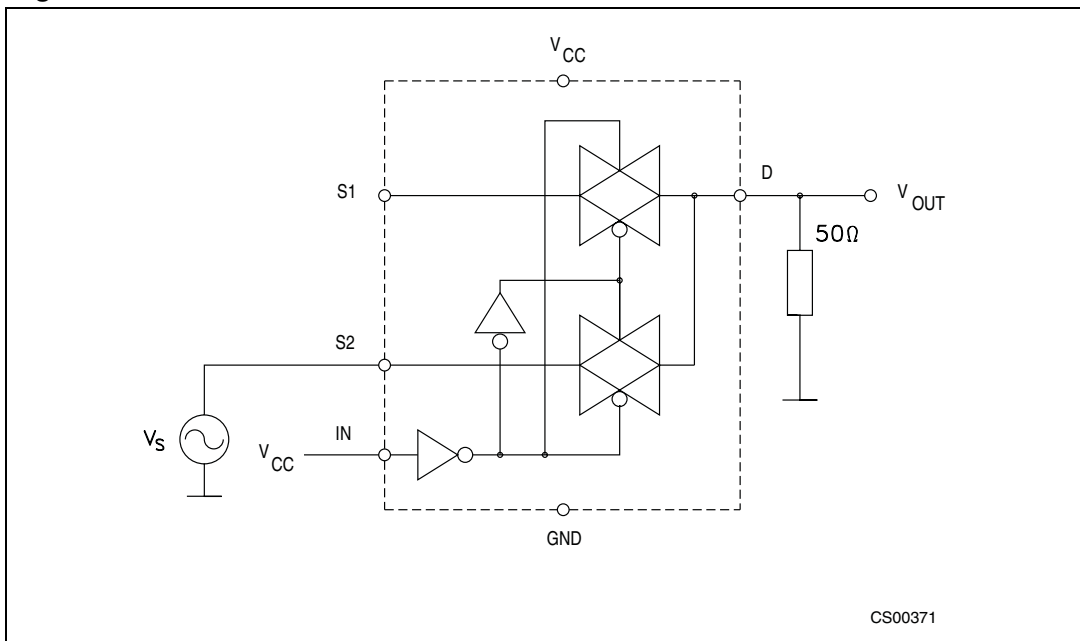

Figure 7. Channel-to-channel crosstalk

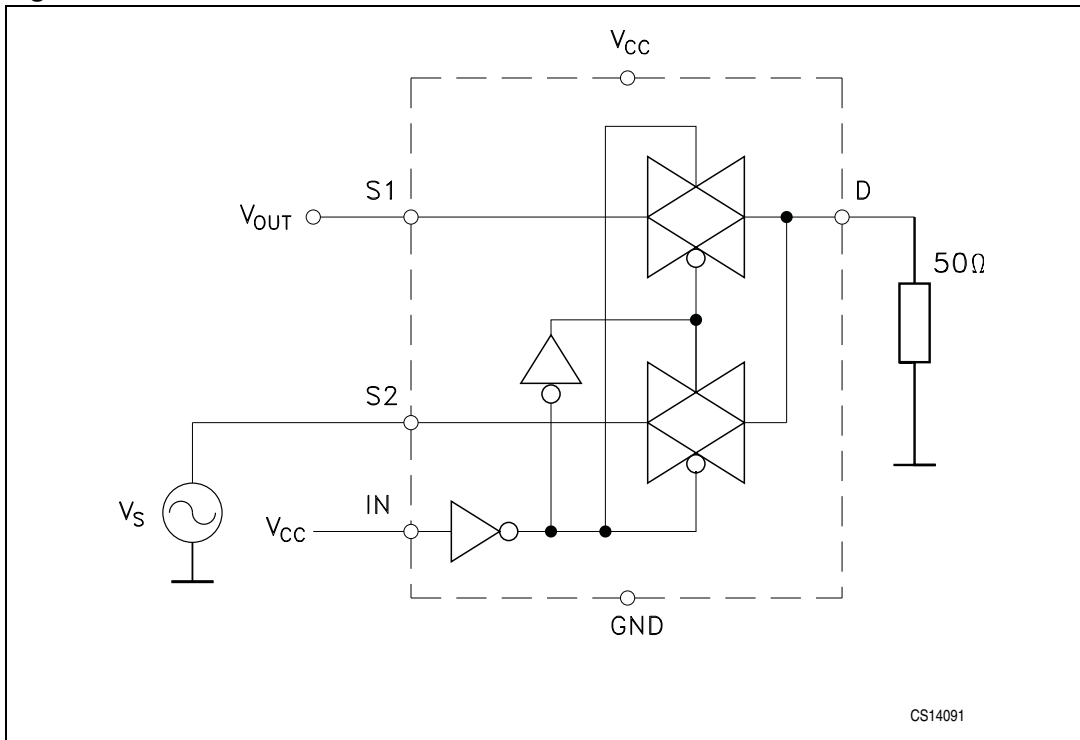
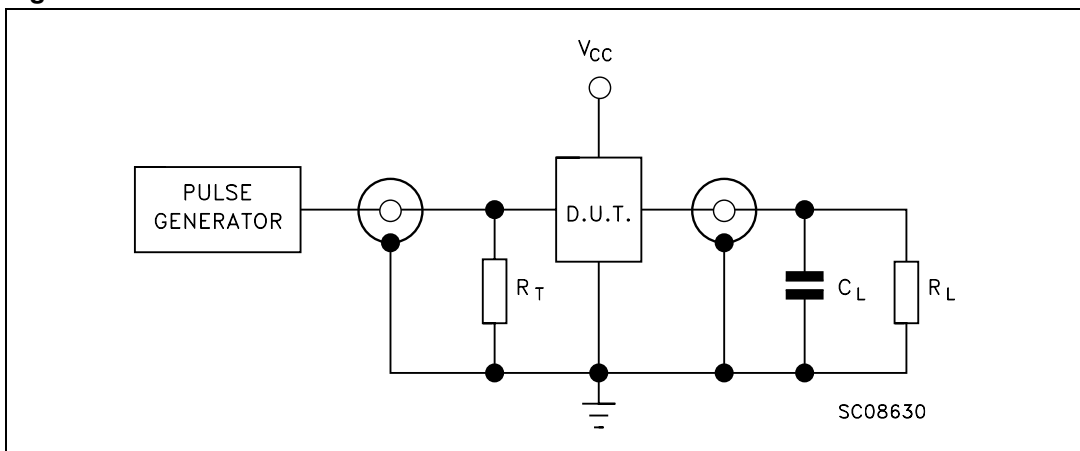
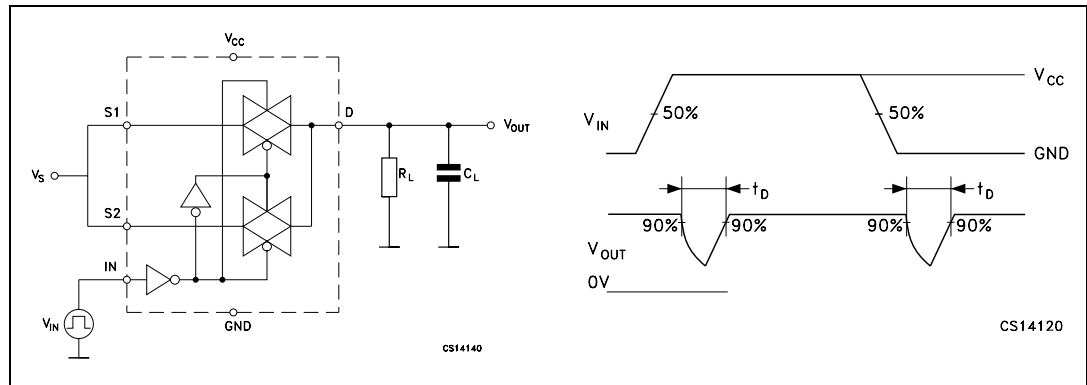

Figure 8. Test circuit



1.  $C_L = 5/35$  pF or equivalent (includes jig and probe capacitance)
2.  $R_L = 50 \Omega$  or equivalent
3.  $R_T = Z_{OUT}$  of pulse generator (typically  $50 \Omega$ )

**Figure 9. Break-before-make time delay**



**Figure 10. Charge injection ( $V_{GEN} = 0$ ,  $R_{GEN} = 0 \Omega$ ,  $R_L = 1 \text{ M}\Omega$ ,  $C_L = 100 \text{ pF}$ )**

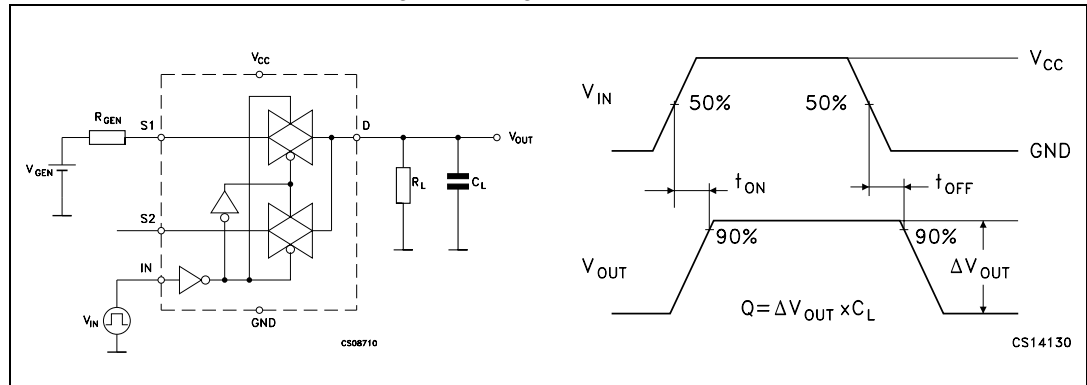

**Figure 11. Turn on, turn off delay time**

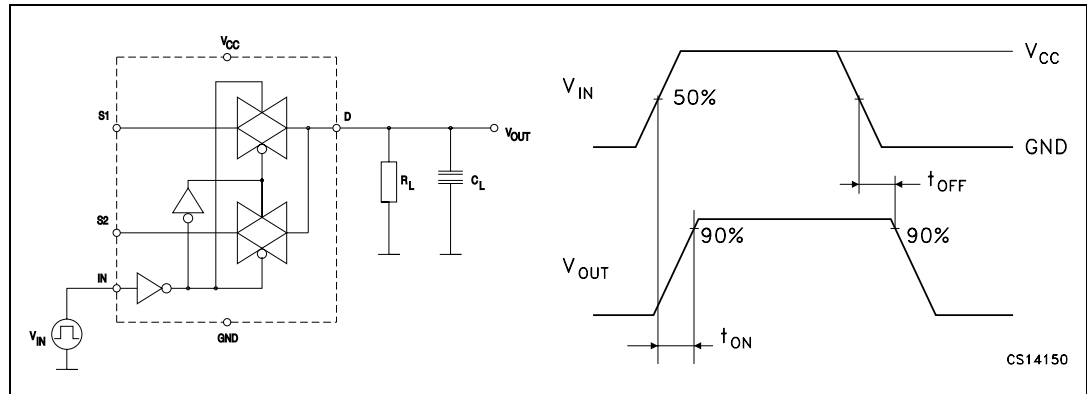

## 6 Package mechanical data

In order to meet environmental requirements, ST offers these devices in different grades of ECOPACK® packages, depending on their level of environmental compliance. ECOPACK® specifications, grade definitions and product status are available at: [www.st.com](http://www.st.com). ECOPACK® is an ST trademark.

**Figure 12. Package outline for QFN10 (1.8 x 1.4 x 0.5 mm) - 0.40 mm pitch**

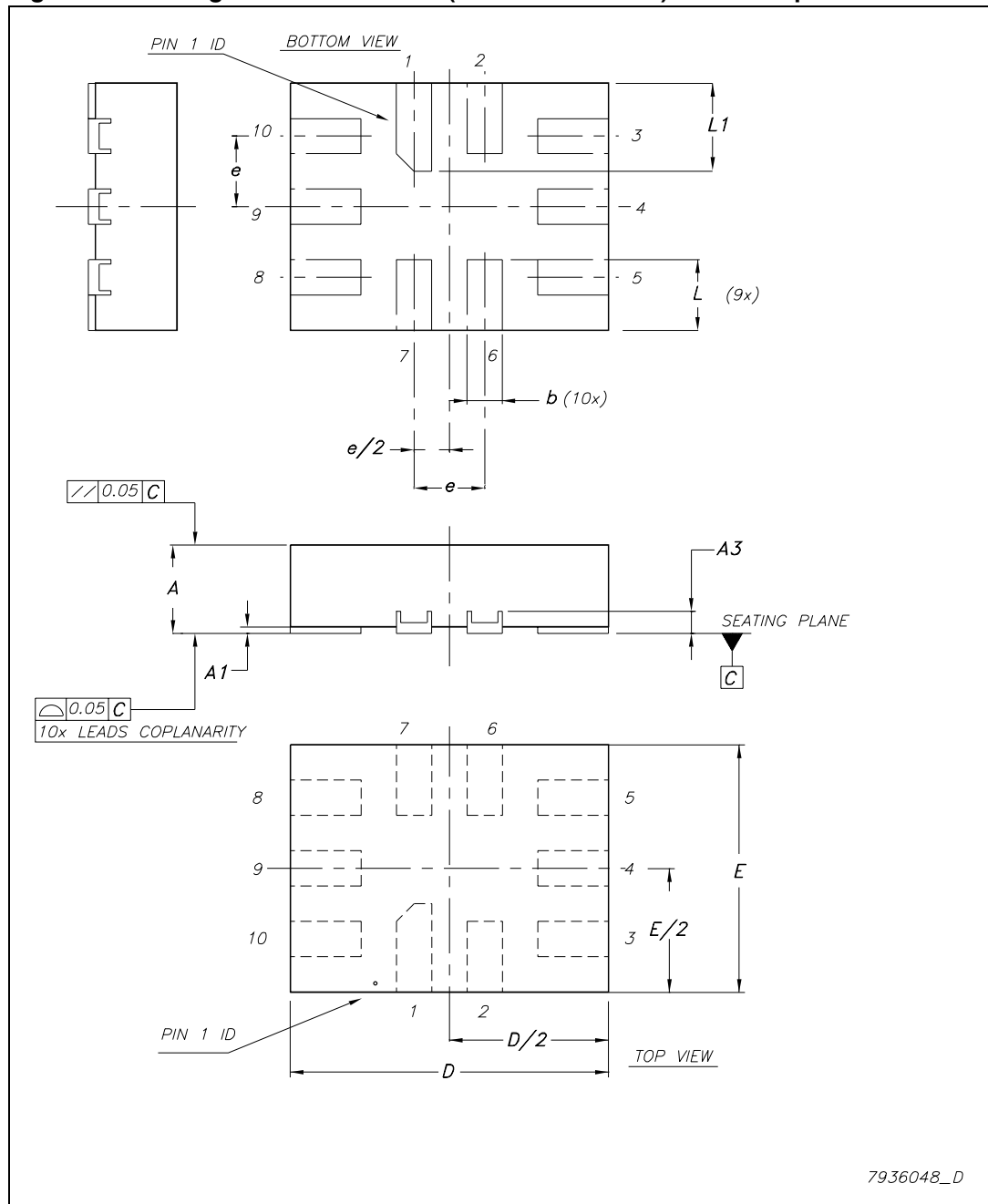

**Table 9. Mechanical data for QFN10 (1.8 x 1.4 x 0.5 mm) - 0.40 mm pitch**

Symbol	Millimeters		
	Min	Typ	Max
A	0.45	0.50	0.55
A1	0	0.02	0.05
A3		0.127	
b	0.15	0.20	0.25
D	1.75	1.80	1.85
E	1.35	1.40	1.45
e		0.40	
L	0.35	0.40	0.45
L1	0.45	0.50	0.55

**Figure 13. Recommended footprint for QFN10 (1.8 x 1.4 x 0.5 mm) - 0.40 mm pitch**

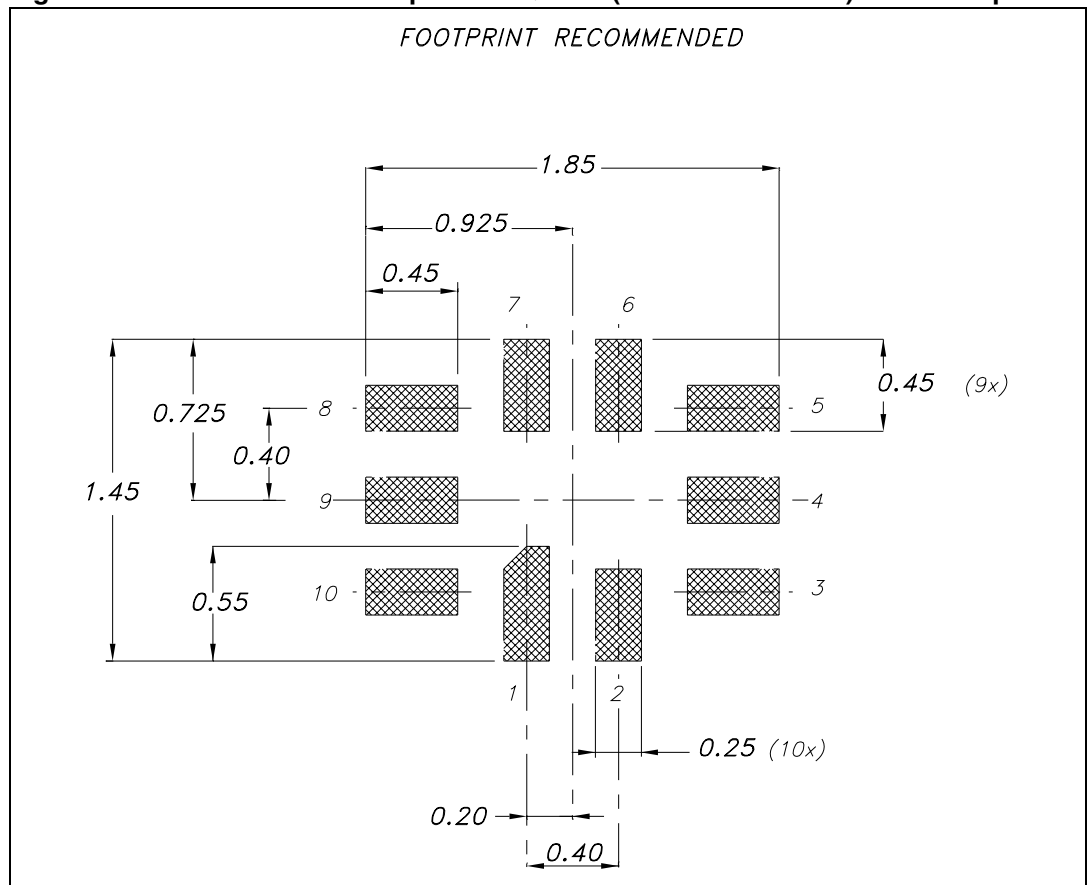

Figure 14. Carrier tape for QFN10 (1.8 x 1.4 x 0.5 mm)

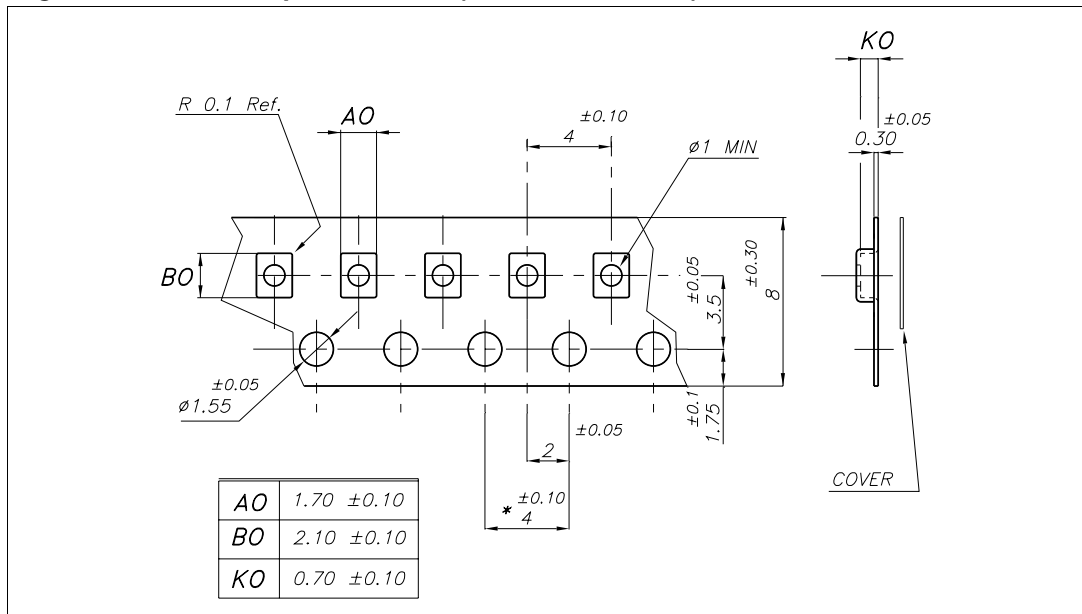

Figure 15. Reel information (back view) for QFN10 (1.8 x 1.4 x 0.5 mm)

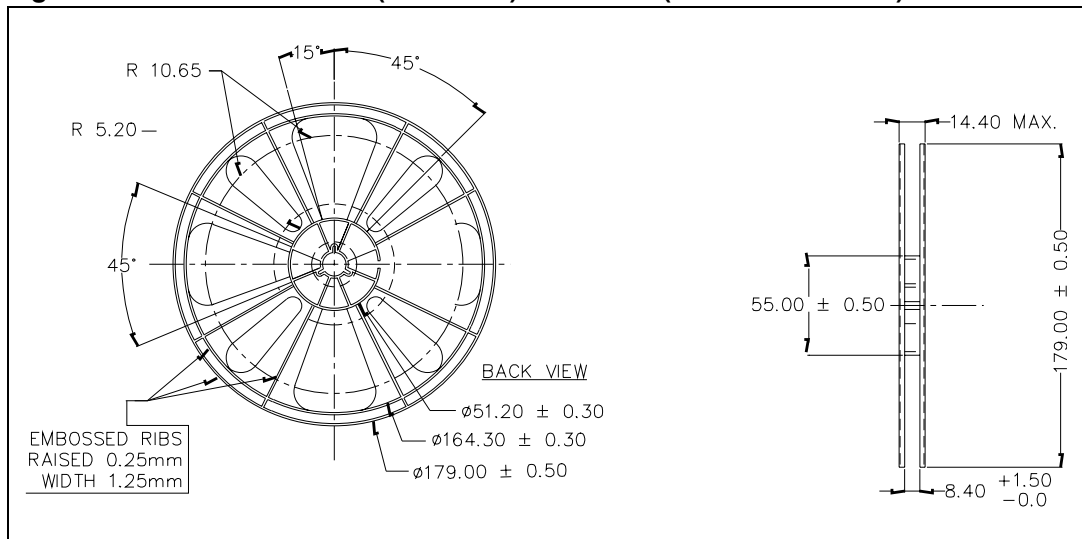
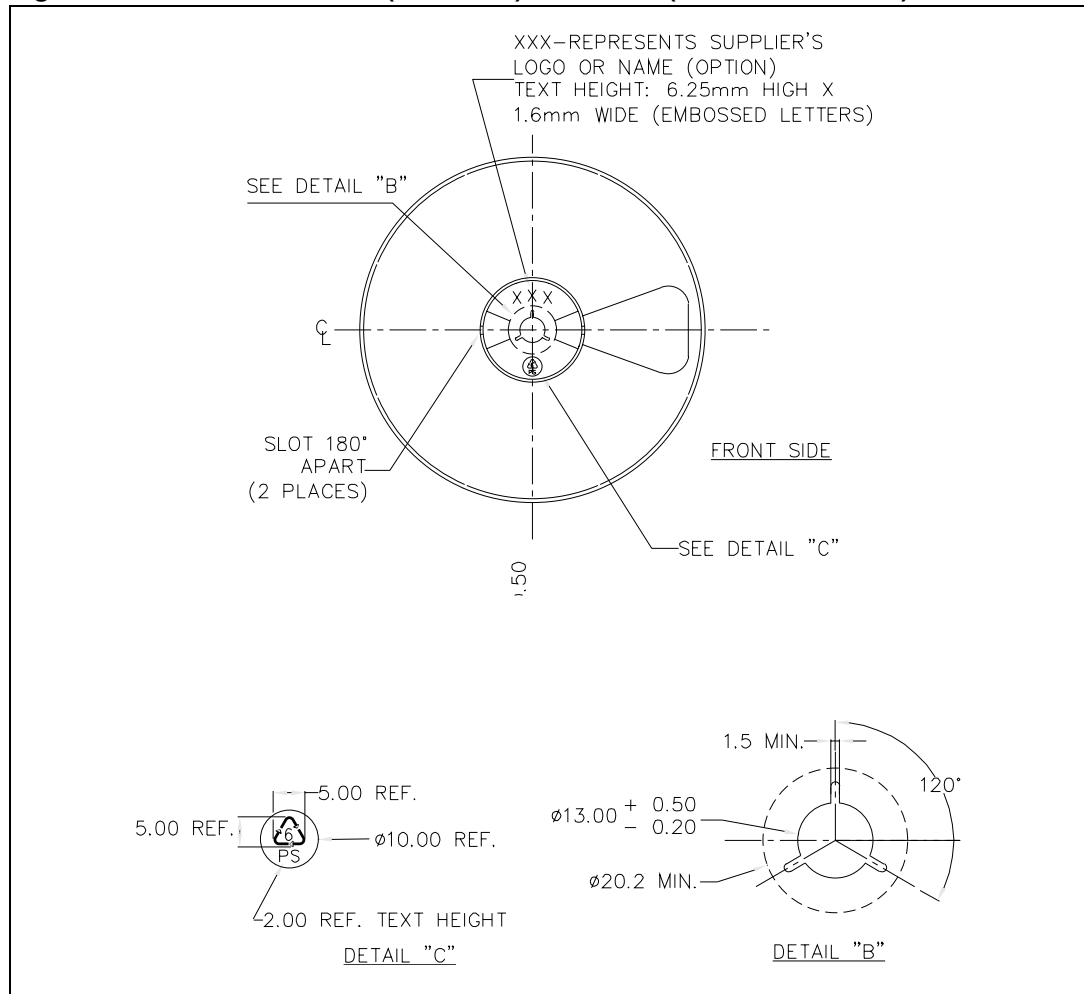



Figure 16. Reel information (front side) for QFN10 (1.8 x 1.4 x 0.5 mm)



## 7 Revision history

**Table 10. Document revision history**

Date	Revision	Changes
06-Dec-2007	1	Initial release.
10-Jul-2008	2	Updated RON and RFLAT in <a href="#">Table 6</a> .
18-May-2009	3	Modified: <a href="#">Table 6</a> and ECOPACK text. Content reworked to improve readability in <a href="#">Section 6</a> .