

## PC8171xNiP0X Series Photocoupler

### Product Specification

August 2006

PC8171xNiP0X Series

Full Specification for part numbers:

PC81710NiP0X

PC81711NiP0X

PC81712NiP0X

PC81713NiP0X

PC81715NiP0X

PC81716NiP0X

PC81718NiP0X

# SHARP

SYSTEM DEVICE DIVISION I  
ELECTRONIC COMPONENTS AND DEVICES GROUP  
SHARP CORPORATION

## SPECIFICATION

DEVICE SPECIFICATION FOR

PHOTOCOUPLER

MODEL No.

PC8171

Business dealing name

	PC81710NIP0X
	PC81711NIP0X
	PC81712NIP0X
	PC81713NIP0X
	PC81715NIP0X
	PC81716NIP0X
	PC81718NIP0X

Specified for \_\_\_\_\_

Enclosed please find copies of the Specifications which consists of 12 pages including cover.  
This specification sheets and attached sheets shall be both side copy.  
After confirmation of the contents, please be sure to send back  copy of the Specifications  
with approving signature on each.

CUSTOMER'S APPROVAL

DATE

\_\_\_\_\_

BY

\_\_\_\_\_

PRESENTED

DATE

\_\_\_\_\_

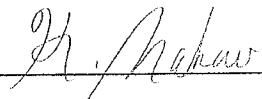
BY 

M. Kubo,  
Department General Manager of  
Development Dept. IV  
System Device Div. I  
Electronic Components and Devices Group  
SHARP CORPORATION

PC81718NIP0X  
**REFERENCE**

Product name : PHOTOCOUPLER

Model No. : PC8171

Business dealing name
PC81710NIP0X
PC81711NIP0X
PC81712NIP0X
PC81713NIP0X
PC81715NIP0X
PC81716NIP0X
PC81718NIP0X

1. These specification sheets include materials protected under copyright of Sharp Corporation ("Sharp"). Please do not reproduce or cause anyone to reproduce them without Sharp's consent.
2. When using this product, please observe the absolute maximum ratings and the instructions for use outlined in these specification sheets, as well as the precautions mentioned below. Sharp assumes no responsibility for any damage resulting from use of the product which does not comply with the absolute maximum ratings and the instructions included in these specification sheets, and the precautions mentioned below.

(Precautions)

- (1) Please do verify the validity of this part after assembling it in customer's products, when customer wants to make catalogue and instruction manual based on the specification sheet of this part.
  - (2) This product is designed for use in the following application areas ;  
(
    - OA equipment    Audio visual equipment    Home appliances
    - Telecommunication equipment (Terminal)    Measuring equipment
    - Tooling machines    Computers)  
If the use of the product in the above application areas is for equipment listed in paragraphs (3) or (4), please be sure to observe the precautions given in those respective paragraphs.
  - (3) Appropriate measures, such as fail-safe design and redundant design considering the safety design of the overall system and equipment, should be taken to ensure reliability and safety when this product is used for equipment which demands high reliability and safety in function and precision, such as ;  
(
    - Transportation control and safety equipment (aircraft, train, automobile etc.)
    - Traffic signals    Gas leakage sensor breakers    Rescue and security equipment
    - Other safety equipment)
  - (4) Please do not use this product for equipment which require extremely high reliability and safety in function and precision, such as ;  
(
    - Space equipment    Telecommunication equipment (for trunk lines)
    - Nuclear power control equipment    Medical equipment)
  - (5) Please contact and consult with a Sharp sales representative if there are any questions regarding interpretation of the above four paragraphs.
3. Please contact and consult with a Sharp sales representative for any questions about this product.

1. Application

This specification applies to the outline and characteristics of photocoupler Model No. PC8171 series (Lead-Free Type).

2. Outline Refer to the attached sheet, page 4.

3. Ratings and characteristics Refer to the attached sheet, page 5, 6.

4. Reliability Refer to the attached sheet, page 7.

5. Outgoing inspection Refer to the attached sheet, page 8.

6. Supplement

6.1 Isolation voltage shall be measured in the following method.

- (1) Short between anode and cathode on the primary side and between collector and emitter on the secondary side.
- (2) The dielectric withstanding tester with zero-cross circuit shall be used.
- (3) The wave form of applied voltage shall be a sine wave.  
(It is recommended that the isolation voltage be measured in insulation oil.)

6.2 Package specifications Refer to the attached sheet, page 9, 10.

6.3 Collector current (Ic) Delivery rank table ("O" mark indicates business dealing name of ordered product)

Rank at delivery	Business dealing name	Rank mark	Ic (mA)	Test conditions
	PC81710NIP0X	With or without	0.5 to 3.0	$I_F=0.5mA$ $V_{CE}=5V$ $T_a=25^{\circ}C$
	PC81711NIP0X	A	0.6 to 1.5	
	PC81712NIP0X	B	0.8 to 2.0	
	PC81713NIP0X	C	1.0 to 2.5	
	PC81715NIP0X	A or B	0.6 to 2.0	
	PC81716NIP0X	B or C	0.8 to 2.5	
	PC81718NIP0X	A, B or C	0.6 to 2.5	

6.4 This Model is approved by UL.

Approved Model No. : PC8171

UL file No. : E64380

6.5 This product is not designed against irradiation.

This product is assembled with electrical input and output.

This product incorporates non-coherent light emitting diode.

6.6 ODS materials

This product shall not contain the following materials.

Also, the following materials shall not be used in the production process for this product.

Materials for ODS : CFCs, Halon, Carbon tetrachloride, 1.1.1-Trichloroethane (Methyl chloroform)

6.7 Specified brominated flame retardants

Specified brominated flame retardants (PBB and PBDE) are not used in this device at all.

6.8 Compliance with each regulation

- (1) The RoHS directive (2002/95/EC)

This product complies with the RoHS directive (2002/95/EC).

Object substances: mercury, lead, cadmium, hexavalent chromium, polybrominated biphenyls (PBB) and polybrominated diphenyl ethers (PBDE)

- (2) Content of six substances specified in Management Methods for Control of Pollution Caused by Electronic Information Products Regulation (Chinese: 电子信息产品污染控制管理办法).

Category	Toxic and hazardous substances					
	Lead (Pb)	Mercury (Hg)	Cadmium (Cd)	Hexavalent chromium (Cr <sup>6+</sup> )	Polybrominated biphenyls (PBB)	Polybrominated diphenyl ethers (PBDE)
Photocopier	✓	✓	✓	✓	✓	✓

✓: indicates that the content of the toxic and hazardous substance in all the homogeneous materials of the part is below the concentration limit requirement as described in SJ/T 11363-2006 standard.

7. Notes

Precautions for photocopiers : Attachment-1

2. Outline

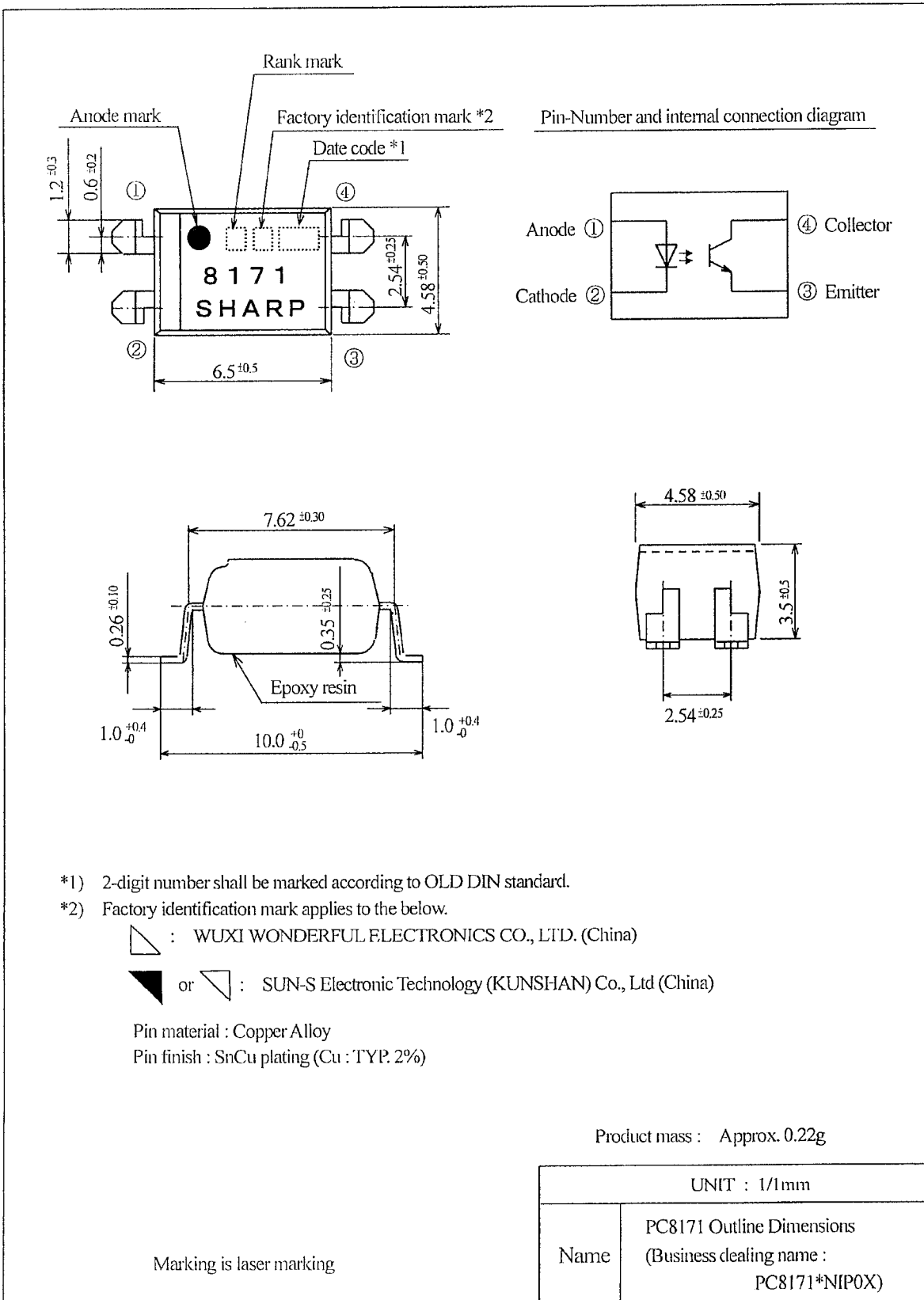

\*1) 2-digit number shall be marked according to OLD DIN standard.

\*2) Factory identification mark applies to the below.

△ : WUXI WONDERFUL ELECTRONICS CO., LTD. (China)

▲ or ▽ : SUN-S Electronic Technology (KUNSHAN) Co., Ltd (China)

Pin material : Copper Alloy

Pin finish : SnCu plating (Cu : TYP. 2%)

### 3. Ratings and characteristics

#### 3.1 Absolute maximum ratings

Ta=25°C

Parameter		Symbol	Rating	Unit
Input	Forward current *1	$I_F$	10	mA
	Peak forward current *2	$I_{FM}$	200	mA
	Reverse voltage	$V_R$	6	V
	Power dissipation *1	P	15	mW
Output	Collector-emitter voltage	$V_{CEO}$	80	V
	Emitter-collector voltage	$V_{ECO}$	6	V
	Collector current	$I_c$	50	mA
	Collector power dissipation *1	$P_c$	150	mW
Total power dissipation *1		$P_{tot}$	170	mW
Operating temperature		$T_{opr}$	-30 to +100	°C
Storage temperature		$T_{stg}$	-55 to +125	°C
Isolation voltage *3		$V_{iso(rms)}$	5	kV
Soldering temperature *4		$T_{sol}$	270	°C

#### 3.2 Electro-optical characteristics

Ta=25°C

Parameter		Symbol	Condition	MIN.	TYP.	MAX.	Unit
Input	Forward voltage	$V_F$	$I_F=5mA$	-	1.2	1.4	V
	Reverse current	$I_R$	$V_R=4V$	-	-	10	$\mu A$
	Terminal capacitance	$C_t$	$V=0, f=1kHz$	-	30	250	pF
Output	Dark current	$I_{CEO}$	$V_{CE}=50V, I_F=0$	-	-	100	nA
	Collector-emitter breakdown voltage	$BV_{CEO}$	$I_c=0.1mA, I_F=0$	80	-	-	V
	Emitter-Collector breakdown voltage	$BV_{ECO}$	$I_E=10\mu A, I_F=0$	6	-	-	V
Transfer characteristics	Collector current	$I_c$	$I_F=0.5mA, V_{CE}=5V$	0.5	-	3.0	mA
	Collector-emitter saturation voltage	$V_{CE(sat)}$	$I_F=10mA, I_c=1mA$	-	-	0.2	V
	Isolation resistance	$R_{ISO}$	DC500V 40 to 60%RH	$5 \times 10^{10}$	$10^{11}$	-	$\Omega$
	Floating capacitance	$C_f$	$V=0, f=1MHz$	-	0.6	1.0	pF
	Response time (Rise)	$t_r$	$V_{CE}=2V, I_c=2mA$	-	4	18	$\mu s$
	Response time (Fall)	$t_f$	$R_L=100\Omega$	-	3	18	$\mu s$
	Common mode rejection ratio *5	CMR	Ta=25°C, $R_L=470\Omega$ $V_{CM}=1.5kV(peak)$ , $I_F=0, V_{CC}=9V$ , $V_{np}=100mV$	10	-	-	kV/ $\mu s$

\*1 The derating factors of absolute maximum ratings due to ambient temperature are shown in Fig. 1 to 4.

\*2 Pulse width  $\leq 100 \mu s$ , Duty ratio : 0.001 (Refer to Fig. 5)

\*3 AC for 1 min, 40 to 60%RH

\*4 For 10s

\*5 Measuring circuit

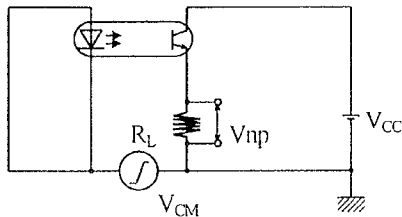

$V_{CM}$ : Higher value of pulse wave  
 $R_L = 470\Omega$   
 $V_{CC} = 9V$

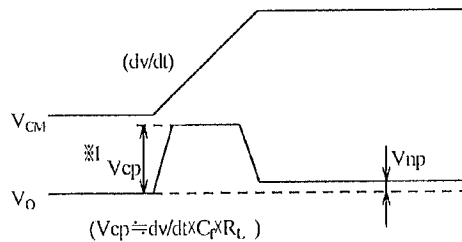

\*1 The voltage generated by a displacement current which flows through floating capacity between primary and secondary side

(Fig. 1)  
 Forward current vs. ambient temperature

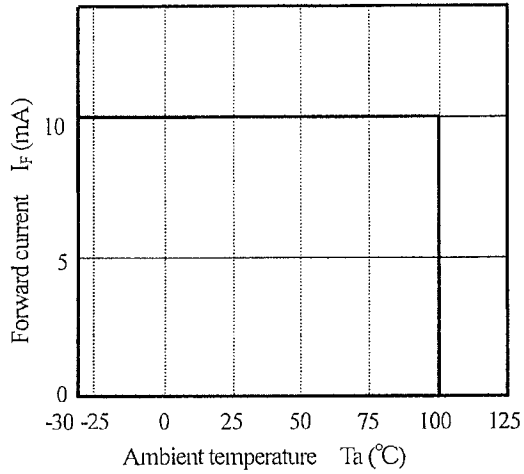

(Fig. 2)  
 Diode power dissipation vs. ambient temperature

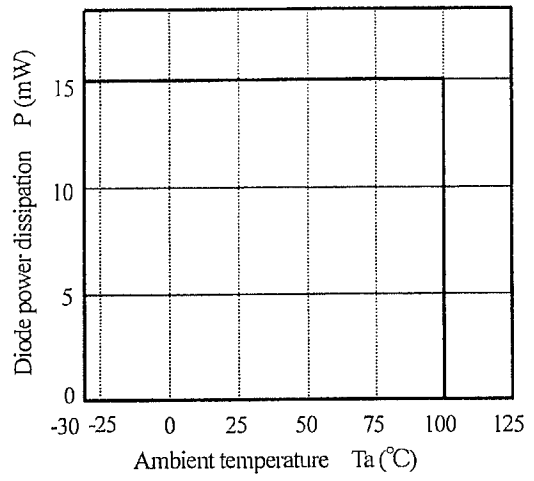

(Fig. 3)  
 Collector power dissipation vs. ambient temperature

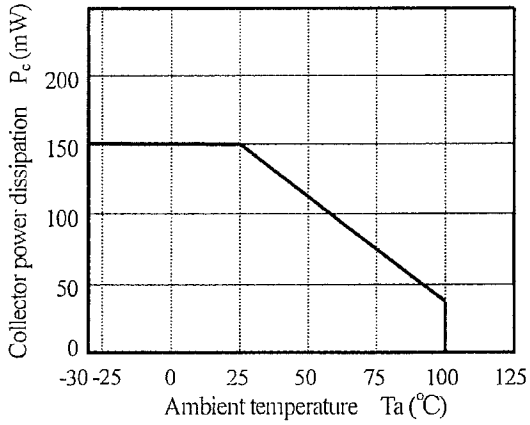

(Fig. 4)  
 Total power dissipation vs. ambient temperature

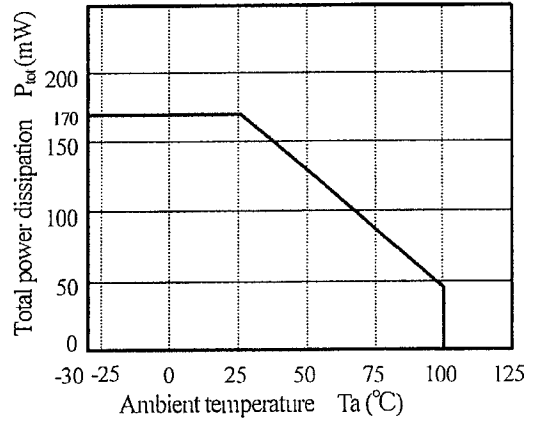

(Fig. 5)  
 Peak forward current vs. duty ratio  
 Pulse width  $\leq 100\mu s$   
 $T_a = 25^\circ C$

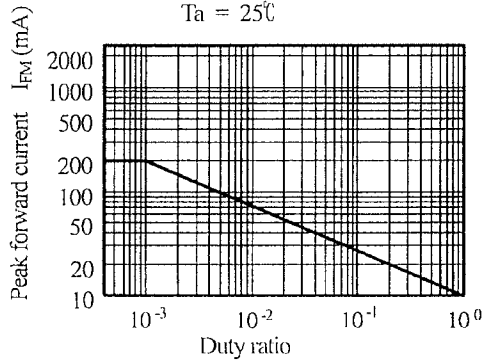



4. Reliability

The reliability of products shall satisfy items listed below.

Confidence level : 90%  
LTPD : 10 or 20

Test Items	Condition	Failure Judgment Criteria	Samples (n) Defective (C)
Solderability	245±3°C, 5s	*2	n=11, C=0
Soldering heat	(Flow soldering) 270°C, 10 s	$V_F > U \times 1.2$ $I_R > U \times 2$ $I_{CEO} > U \times 2$ $I_C < L \times 0.7$ $V_{CE(sat)} > U \times 1.2$  U: Upper specification limit L: Lower specification limit	n=11, C=0
	(Soldering by hand) 400°C, 3 s		n=11, C=0
Terminal strength (Tension)	Weight: 5N 5 s/each terminal		n=11, C=0
Terminal strength (Bending) *3	Weight: 2.5N 2 times/each terminal		n=11, C=0
Mechanical shock	15km/s <sup>2</sup> , 0.5ms 3 times/±X, ±Y, ±Z direction		n=11, C=0
Variable frequency vibration	100 to 2000 to 100Hz/4 min 200m/s <sup>2</sup> 4 times/X, Y, Z direction		n=11, C=0
Temperature cycling	1 cycle -55 °C to +125 °C (30 min) (30 min) 20 cycles test		n=22, C=0
High temp. and high Humidity storage	+85°C, 85%RH, 1000h		n=22, C=0
High temp. storage	+125 °C, 1000h		n=22, C=0
Low temp. storage	-55 °C, 1000h		n=22, C=0
Operation life	I <sub>F</sub> =10mA, P <sub>tot</sub> =170mW T <sub>a</sub> =25 °C, 1000h	n=22, C=0	

\*1 Test method, conforms to EIAJ ED 4701.

\*2 The product whose not-soldered area is more than 5% for all of the dipped area and/or whose pinholes or voids are concentrated on one place shall be judged defect.

\*3 Terminal bending direction is shown below.

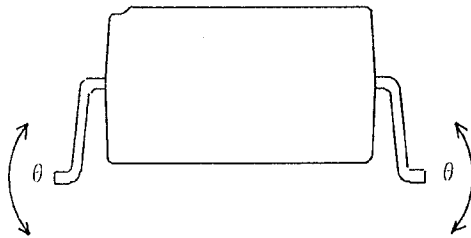

## 5. Outgoing inspection

## 5.1 Inspection items

- (1) Electrical characteristics  
 $V_F$ ,  $I_R$ ,  $I_{CEO}$ ,  $V_{CE(sat)}$ ,  $I_c$ ,  $R_{ISO}$ ,  $V_{iso}$
- (2) Appearance

## 5.2 Sampling method and Inspection level

A single sampling plan, normal inspection level II based on ISO 2859 is applied.

The AQL according to the inspection items are shown below.

Defect	Inspection item	AQL (%)
Major defect	Electrical characteristics Unreadable marking	0.065
Minor defect	Appearance defect except the above mentioned.	0.25

6.2 Package specifications

6.2.1 Taping conditions

- (1) Tape structure and Dimensions (Refer to the attached sheet, Page 9)  
The carrier tape has the heat pressed structure of PS material carries tape and three layers cover tape (PET material base).
- (2) Reel structure and Dimensions (Refer to the attached sheet, Page 10)  
The taping reel shall be of plastic (PS material).
- (3) Direction of product insertion (Refer to the attached sheet, Page 10)
- (4) Joint of tape  
The cover tape and carrier tape in one reel shall be joint less.
- (5) To repair taped failure devices cutting a bottom of carrier tape with a cutter.  
After replacing the cut portion shall be sealed with adhesive tape.

6.2.2 Adhesiveness of cover tape

- The exfoliation force between carrier tape and cover tape shall be 0.2N to 0.7N for the angle 160° to 180° .

6.2.3 Rolling method and quantity

- Wind the tape back on the reel so that the cover tape will be outside the tape.  
Attach more than 20cm of blank tape to the trailer and the leader of the and fix the both ends with adhesive tape.  
One reel basically shall contain 2000pcs.

6.2.4 Outer packing appearance

- Refer to the attached sheet, page 10.

6.2.5 Marking

The label with following information shall be pasted at appointed place of the outer packing case.

- \* Model No. \*(Business dealing name) \* Lot No. \* Quantity
- \* Country of origin \*Company name \*Inspection date specified

6.2.6 Storage condition

- Taped products shall be stored at the temperature 5 to 30°C and the humidity 70%RH or less  
away from direct sunlight.

6.2.7 Safety protection during shipping

- There shall be no deformation of component or degradation of electrical characteristics due to shipping.

Carrier tape structure and Dimensions

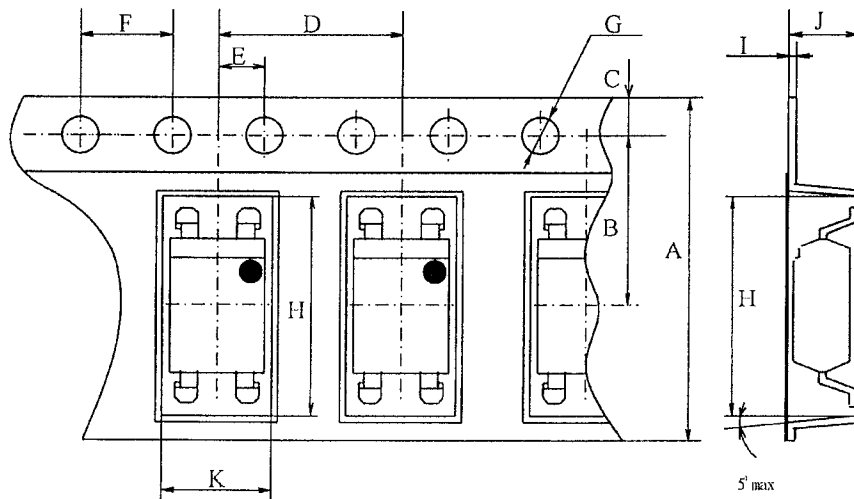

Dimensions list (Unit : mm)

A	B	C	D	E	F	G	H	I	J	K
±0.3	±0.1	±0.10	±0.1	±0.1	±0.1	+0.1 -0.0	±0.1	±0.05	±0.1	±0.1
16.0	7.5	1.75	8.0	2.0	4.0	φ 1.5	10.4	0.40	4.2	5.1

# BC8171NIPDX REFERENCE

## Reel structure and Dimensions

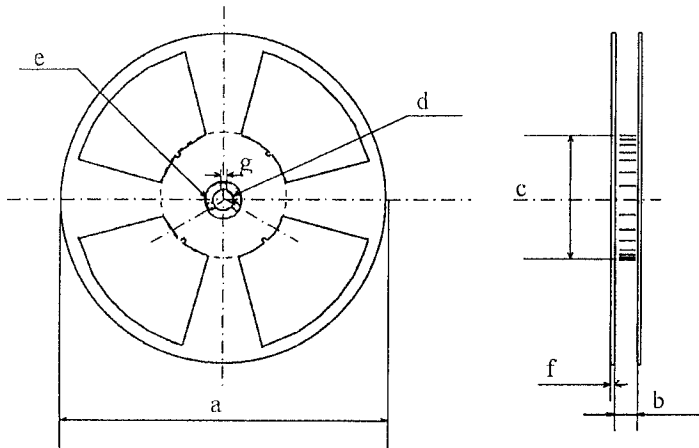

Dimensions list (Unit : mm)

a	b	c	d
(330)	17.5±1.5	φ 100.0±1.0	φ 13.0±0.5
e	f	g	
φ 23.0±1.0	2.0±0.5	2.0±0.5	

## Direction of product insertion

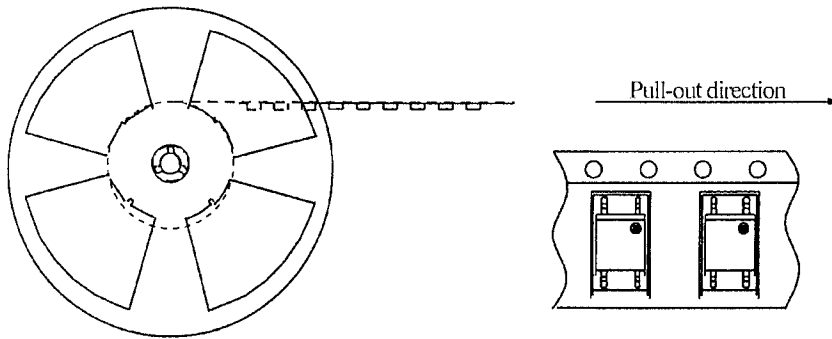

## Outer packing appearance

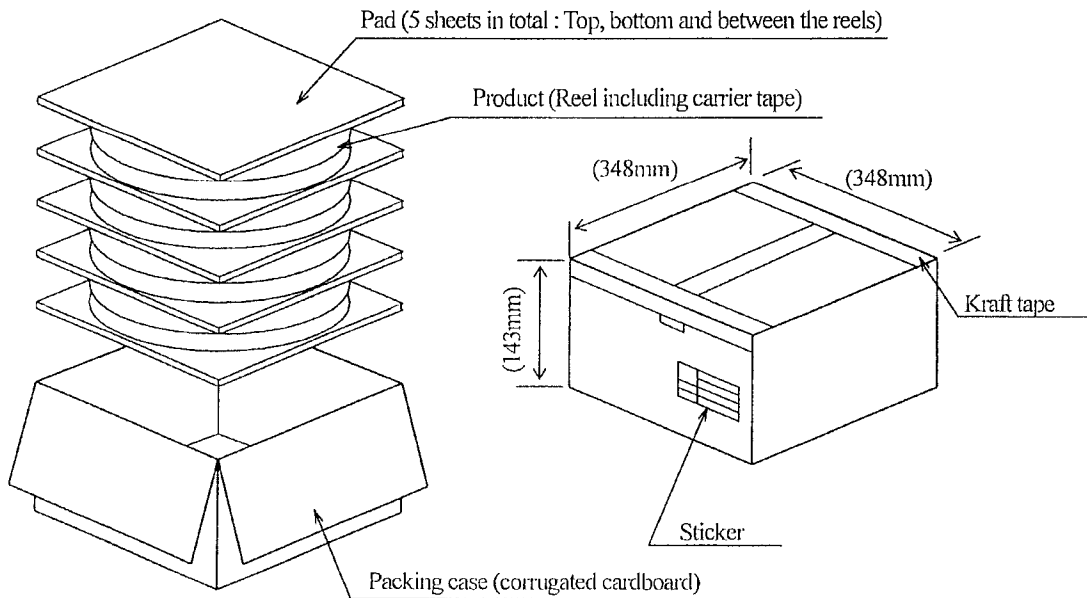

Regular packing mass : Approx. 4.1kg  
 ( ) : Reference dimensions

Precautions for Photocouplers

## 1. Cleaning

- (1) Solvent cleaning : Solvent temperature 45°C or less  
Immersion for 3 min or less
- (2) Ultrasonic cleaning : The effect to device by ultrasonic cleaning differs by cleaning bath size, ultrasonic power output, cleaning time, PCB size or device mounting condition etc. Please test it in actual using condition and confirm that any defect doesn't occur before starting the ultrasonic cleaning.
- (3) Applicable solvent : Ethyl alcohol, Methyl alcohol, Isopropyl alcohol  
When the other solvent is used, there are cases that the packaging resin is eroded.  
Please use the other solvent after thorough confirmation is performed in actual using condition.

## 2. Circuit design

- (1) The LED used in the Photocoupler generally decreases the light emission power by operation.  
In case of long operation time, please design the circuit in consideration of the degradation of the light emission power of the LED. (50%/5years)
- (2) There are cases that the deviation of the CTR and the degradation of the relative light emission power of the LED increase when the setting value of  $I_F$  is less than 0.5mA. Please design the circuit in consideration of this point
- (3) When steep voltage noise is applied between the primary side and the secondary side of the photocoupler, current flows or changes in the light emitting diode through a parasitic capacitance between the primary side and the secondary side of the photocoupler; then there is a case that miss operation occurs depending upon the applied noise level.  
We should certainly recommend to use a by-pass capacitor between both terminals of the light emitting diode where used in noisy environment.

## 3. Precautions for Soldering

- (1) In the case of flow soldering (Whole device dipping.)  
It is recommended that flow soldering should be at 270°C or less for 10 s or less  
(Pre-heating : 100 to 150°C, 30 to 80s). (2 times or less)
- (2) If solder reflow :  
It is recommended to be done at the temperature and the time within the temperature profile as shown in the figure below. (2 times or less)

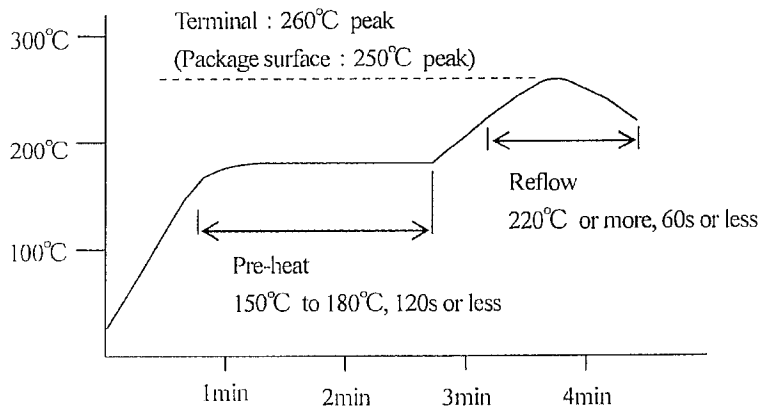

- (3) In the case of hand soldering  
What is done on the following condition is recommended.( 2 times or less)  
Soldering iron temperature : 400°C or less  
Time : 3s or less
- (4) Other precautions  
Depending on equipment and soldering conditions (temperature, Using solder etc.), the effect to the device and the PCB is different.  
Please confirm that there is no problem on the actual use conditions in advance.

# Opto Specification

## Opto/EC Group



### NORTH AMERICA

Sharp Microelectronics of the Americas  
5700 NW Pacific Rim Blvd.  
Camas, WA 98607, U.S.A.  
Phone: (1) 360-834-2500  
Fax: (1) 360-834-8903  
www.sharpsma.com

### TAIWAN

Sharp Electronic Components  
(Taiwan) Corporation  
8F-A, No. 16, Sec. 4, Nanking E. Rd.  
Taipei, Taiwan, Republic of China  
Phone: (886) 2-2577-7341  
Fax: (886) 2-2577-7326/2-2577-7328

### CHINA

Sharp Microelectronics of China  
(Shanghai) Co., Ltd.  
28 Xin Jin Qiao Road King Tower 16F  
Pudong Shanghai, 201206 P.R. China  
Phone: (86) 21-5854-7710/21-5834-6056  
Fax: (86) 21-5854-4340/21-5834-6057  
Head Office:  
No. 360, Bashen Road,  
Xin Development Bldg. 22  
Waigaoqiao Free Trade Zone Shanghai  
200131 P.R. China  
Email: smc@china.global.sharp.co.jp

### EUROPE

Sharp Microelectronics Europe  
Division of Sharp Electronics (Europe) GmbH  
Sonninstrasse 3  
20097 Hamburg, Germany  
Phone: (49) 40-2376-2286  
Fax: (49) 40-2376-2232  
www.sharpsme.com

### SINGAPORE

Sharp Electronics (Singapore) PTE., Ltd.  
438A, Alexandra Road, #05-01/02  
Alexandra Technopark,  
Singapore 119967  
Phone: (65) 271-3566  
Fax: (65) 271-3855

### KOREA

Sharp Electronic Components  
(Korea) Corporation  
RM 501 Geosung B/D, 541  
Dohwa-dong, Mapo-ku  
Seoul 121-701, Korea  
Phone: (82) 2-711-5813 ~ 8  
Fax: (82) 2-711-5819

### JAPAN

Sharp Corporation  
Electronic Components & Devices  
22-22 Nagaïke-cho, Abeno-Ku  
Osaka 545-8522, Japan  
Phone: (81) 6-6621-1221  
Fax: (81) 6117-725300/6117-725301  
www.sharp-world.com

### HONG KONG

Sharp-Roxy (Hong Kong) Ltd.  
Level 26, Tower 1, Kowloon Commerce Centre,  
No. 51, Kwai Cheong Road, Kwai Chung,  
New Territories, Hong Kong  
Phone: (852) 28229311  
Fax: (852) 28660779  
www.sharp.com.hk  
Shenzhen Representative Office:  
Room 602-603, 6/F,  
International Chamber of Commerce Tower,  
168 Fuhua Rd. 3, CBD,  
Futian District, Shenzhen 518048,  
Guangdong, P.R. China  
Phone: (86) 755-88313505  
Fax: (86) 755-88313515

SPECIFICATIONS ARE SUBJECT TO CHANGE WITHOUT NOTICE.

Suggested applications (if any) are for standard use; See Important Restrictions for limitations on special applications. See Limited Warranty for SHARP's product warranty.

The Limited Warranty is in lieu, and exclusive of, all other warranties, express or implied.

ALL EXPRESS AND IMPLIED WARRANTIES, INCLUDING THE WARRANTIES OF MERCHANTABILITY, FITNESS FOR USE AND FITNESS FOR A PARTICULAR PURPOSE, ARE SPECIFICALLY EXCLUDED. In no event will SHARP be liable, or responsible in any way, for any incidental or consequential economic or property damage.