

PREPARED BY : DATE	 DISPLAY DEVICE BUSINESS GROUP SHARP CORPORATION SPECIFICATION	FILE No. LD-27108A
APPROVED BY : DATE		ISSUE : 27-Jan-15
		PAGE : 28pages APPLICABLE GROUP DISPLAY DEVICE BUSINESS GROUP

REVISION : 27-Jan-15

DEVICE SPECIFICATION FOR
LCD Module
 MODEL No.
LS012B7DD01

These parts are complied with the RoHS directive.

CUSTOMER'S APPROVAL

BY _____

BY 
 T. Ohnishi

DEPARTMENT GENERAL MANAGER
 DEVELOPMENT DEPARTMENT III
 DISPLAY DEVICE UNIT III
 DISPLAY DEVICE BUSINESS DIVISION I
 SHARP CORPORATION

NOTICE**<<Precautions>>**

- a) This publication is the proprietary of SHARP and is copyrighted, with all rights reserved. Under the copyright laws, no part of this publication may be reproduced or transmitted in any form or by any means, electronic or mechanical for any purpose, in whole or in part, without the express written permission of SHARP. Express written permission is also required before any use of this publication may be made by a third party.
- b) The application circuit examples in this publication are provided to explain the representative applications of SHARP's devices and are not intended to guarantee any circuit design or permit any industrial property right or other rights to be executed. SHARP takes no responsibility for any problems related to any industrial property right or a third party resulting from the use of SHARP's devices, except for those resulting directly from device manufacturing processes.
- c) When using the products covered herein, please observe the conditions and the precautions written herein. In no event shall the company be liable for any damages resulting from failure to strictly adhere to these conditions and precautions.
- d) SHARP reserves the right to make changes in the specifications, characteristics, data, materials, structures and other contents described herein at any time without notice in order to improve design or reliability. Contact SHARP in order to obtain the latest specification sheets before using any SHARP's device. Manufacturing locations are also subject to change without notice.
- e) The devices in this publication are designed for general electronic equipment use.
- f) The appropriate design measures should be taken to ensure reliability and safety when SHARP's devices are used for equipment such as:
- Transportation control and safety equipment(i.e.,aircraft, trains, automobiles, etc.)
 - Traffic signals
 - Alarm equipment
 - Gas leakage sensor breakers
 - Various safety devices etc.
- g) SHARP's devices shall not be used for equipment that requires extremely high level of reliability, such as:
- Aerospace equipment
 - Nuclear power control equipment
 - Trunk line commucation equipment
 - Military and space applications
 - Medical equipment for life support
- h) Contact and consult with a SHARP representative in advance, if there are any questions about the contents of this publication.

- i) Contact a SHARP representative, in advance, when intending to use SHARP's devices for any "specific" applications other than those recommended by SHARP.
- j) If any problem occurs in relation to the description of this publication, it shall be resolved through discussion with spirit of cooperation each corporation between each corporation.
- k) The ozone-depleting substances are not used.
- l) The device in the production is based on RoHS instructions 95/02.
And RoHS instructions materials and chlorinated paraffin are not included intentionally.

[Handling Instructions]

【Handling Precautions】

- (1) Treat LCD module in dustless surroundings.
- (2) Be sure to turn off the power supply when remove the plugged FPC.
- (3) Be careful not to give any physical stress onto the circuit of LCD module when you plug a FPC.
Physical stress will cause a break or worse connection.
- (4) Do not touch or scratch the polarizer with items harder than the surface rating or permanent damage can result.
- (5) Since the LCD panel is made of glass, it may break or crack if dropped or bumped on hard surface.
Always handle with care.
- (6) Be careful to handle this LCD panel in order to avoid injury yourself as this panel is made of glass and have sharp edge. When the panel is broken, do not touch the glass. Although the panel is difficult to be scattered, touching the broken part may hurt your hands.
- (7) Since a long contact with water may cause discoloration or spots, wipe it with absorbent cotton or other soft cloth immediately.
- (8) This module contains CGS. Please use appropriate anti-static protection methods for all contact with the LCD panel and its electrical circuits.
- (9) Do not expose to strong ultraviolet rays such as direct sunlight for a long time.
- (10) Liquid crystal contained in the panel may leak if the LCD is broken. If LC material should accidentally come in contact with the mouth or eyes rinse with water as soon as possible, following the instructions of the appropriate MSDS.
- (11) Use N2-blower such as ionized nitrogen has anti-electrostatic when you blow dusts on Polarizer.
To clean LCD panel surface, wipe clean with absorbent cotton or soft cloth.
If further cleaning is needed, use IPA(isopropyl alcohol) and wipe clean lightly on surface only.
Do not use organic solvents as it may damage the LCD panel terminal area which uses organic material.
Also, do not directly touch with finger. When the terminals cleaning are needed, those should be wiped by a soft cloth or a cotton swab without directly touching by hand.
- (12) To avoid picture uniformity failure, do not put a seal or an adhesive material on the LCD panel surface.

【Set-Design Precautions】

- (1) Disassembly of the LCD panel in any way voids the warranty and may permanently damage the LCD panel.
- (2) Do not expose the side of LCD panel and gate driver, etc. on the panel (circuit area outside panel display area) to light as it may not operate properly. Design that shields the side of LCD panel and gate driver, etc. from light is required when mounting the LCD module.
- (3) Support for the LCD panel should be carefully designed to avoid the outside of stress specification on glass surface. Be sure to design the cabinet so that the module can be assembled without any extra stress such as warp or twist.
- (4) It causes an irregular display and the defective indication, etc., when always put constant pressure on the back of the module. Please do not make the structure to press the back of the module.
- (5) In case of attaching a cover glass or touch panel to the front surface, use appropriate measures to avoid degrading optical performance.
- (6) To prevent loss of uniformity and prevent the introduction of contamination to the optical path of the LCD panel, please use fine-pitch filters in the air flow of forced ventilation.
- (7) Be sure to follow the absolute maximum rating in the specification. The design should consider the surrounding temperature, the fluctuating input signal, and tolerance of the electronic parts. Exceeding values is possible to cause worse characteristic such as burn and/or broken of the parts on LCD module.
- (8) Be sure to use LCD module within the recommended Electrical Characteristics and Timing Characteristics of Input Signals conditions.
Operating module out of the recommended range is not guaranteed even if it is in the absolute maximum rating.
- (9) Follow the power, signal, and supply voltage sequence which the specification indicates, regarding on-off input signal after power on of LCD module.
- (10) According to the using application, power circuit protection is recommended at module failure.
- (11) When handling LCD modules and assembling them into the cabinet, please avoid long-term storage in the environment of oxidization or deoxidization gas. The use of materials such as reagent, solvent, adhesive, resin, etc. which generate these gasses, may cause corrosion and discoloration of the modules.
Do not use the LCD module under such environment.
- (12) To avoid picture uniformity failure, do not put a seal or an adhesive material on the LCD panel surface.
- (13) Protection film is attached to the module surface to prevent it from being scratched .
Peel the film off slowly, just before the use, with strict attention to electrostatic charges.
Blow off 'dust' on the polarizer by using an ionized nitrogen.
After peeling the protection film off, please do not reattach to the front polarizer.
If you reattach and store it long time, surface of the front polarizer changes in quality and it may cause display non-uniformity issue.

(14) Panel is susceptible to mechanical stress and such stress may affect the display.

Place the LCD panel on flat surface to avoid stress caused by twist, bend, etc.

(15) To prevent reduction in optical quality and abnormal display, avoid exposure and contamination of the LCD panel from epoxy resin (mine system curing agent) that comes out from the material and the packaging material used for the set side, the silicon adhesive (dealcoholization system and oxime system), and the tray blowing agents (azo-compound), etc. Please confirm LCD panel compatibility with materials employed in your manufacturing and shipping processes.

(16) Since the LCD panel is made of glass, it may break or crack if dropped or bumped on hard surface. Always handle with care.

(17) Please design part arrangement to consider the heat dissipation not to change the local temperature for module.

(18) This product is not water-proof and dust-proof structure.

(19) As this LCD module is composed electronic circuits, it is sensitive to electrostatic discharge of 200V or more. Handle with care using cautions for the followings:

- Operators

Operators must wear anti-static wears to prevent electrostatic charge up to and discharge from human body.

- Equipment and containers

Process equipment such as conveyer, soldering iron, working bench and containers may possibly generate electrostatic charge up and discharge. Equipment must be grounded through 100Mohms resistance. Use ion blower.

- Floor

Floor plays an important role in leaking static electricity generated in human body or equipment. If the floor is made of insulated material (such as polymer or rubber material), such static electricity may charge. Proper measure should be taken to avoid static electricity charge (electrostatic earth: 100Mohms). There is a possibility that the static electricity is charged to them without leakage in case of insulating floor, so the electrostatic earth: 100Mohms should be made.

- Humidity

Humidity in work area relates to surface resistance of the persons or objects that generate electrostatics, and it can be manipulated to prevent electrostatic charge. Humidity of 40% or lower increases electrostatic earth resistance and promotes electrostatic charging. Therefore, the humidity in the work area should be kept above 40%. Specifically for film peeling process or processes that require human hands, humidity should be kept above 50% and use electricity removal blower.

- Transportation/Storage

Containers and styroform used in transportation and storage may charge electrostatic (from friction and peeling) or electrostatic charge from human body, etc. may cause containers and styroform to have induced charge. Proper electrostatic measure should be taken for containers and storage material.

【Operation Precautions】

- (1) Do not use polychloroprene (CR) with LCD module. It will generate chlorine gas, which will damage the reliability of the connection part on LCD panel.
- (2) Be sure to use LCD module within the recommended operating conditions.
Operating module out of the recommended range is not guaranteed even if it is in the absolute maximum rating.
- (3) When handling LCD modules and assembling them into cabinets, please avoid long-term storage in the environment of oxidization or deoxidization gas. The use of materials such as reagent, solvent, adhesive, resin, etc. which generate these gasses, may cause corrosion and discoloration of the modules.
Do not use the LCD module under such environment.
- (3) To prevent reduction in optical quality and abnormal display, avoid exposure and contamination of the LCD panel from epoxy resin (amine system curing agent) that comes out from the material and the packaging material used for the set side, the silicon adhesive (dealcoholization system and oxime system), and the tray blowing agents (azo-compound), etc.
Please confirm LCD panel compatibility with materials employed in your manufacturing and shipping processes.
- (4) If stored at the temperatures lower than the rated storage temperature, the LC may freeze and it may cause LCD panel damage. And If stored at the temperatures higher than the rated storage temperature, the LC will lose its characteristics, and it cannot recover. Please keep it at near room temperature.
- (5) Do not operate the LCD panel under outside of electrical specification. Otherwise LCD panel may be damaged.
- (6) Do not use the LCD panel under outside of specified driving timing chart. Otherwise LCD panel may not have proper picture quality.
- (7) A still image should be displayed less than two hours, if it is necessary to display still image longer than two hour, display image data must be refreshed in order to avoid sticking image on LCD panel.
- (8) If LCD module takes a static electricity, as the display image which is written into pixel memory might not be displayed, Data update should be executed frequently.
- (9) It is neither a breakdown nor a defective indication though very slight change in black level might be periodically seen in a black part on the black display image according to the source of light (angle of the luminance and the source of light).
- (10) Be sure to follow the absolute maximum rating in the specification. The design should consider the surrounding temperature, the fluctuating input signal, and tolerance of the electronic parts.
Exceeding values is possible to cause worse characteristic such as burn and/or broken of the parts on LCD module.
- (11) Follow the power, signal, and supply voltage sequence which the specification indicates, regarding on-off input signal after power on of LCD module.
- (12) According to the using application, power circuit protection is recommended at module failure.
- (13) Nature of dew consideration prevention is necessary when LCD is used for long time under high-temperature and high-humidity

. [Precautions for Storage]

(1) After opening the package, do not leave the LCD panel in direct sun or under strong ultraviolet ray.

Store in the dark place.

(2) In temperature lower than specified rating, liquid crystal material will coagulate.

In temperature higher than specified rating, it will liquefies. In either condition, the liquid crystal may not recover its original condition. Store the LCD panel in at or around room temperature as much as possible.

Also, storing the LCD panel in high humidity will damage the polarizer.

Store in normal room temperature as much as possible.

(3) Keeping Method

a. Don't keeping under the direct sunlight.

b. Keeping in the tray under the dark place.

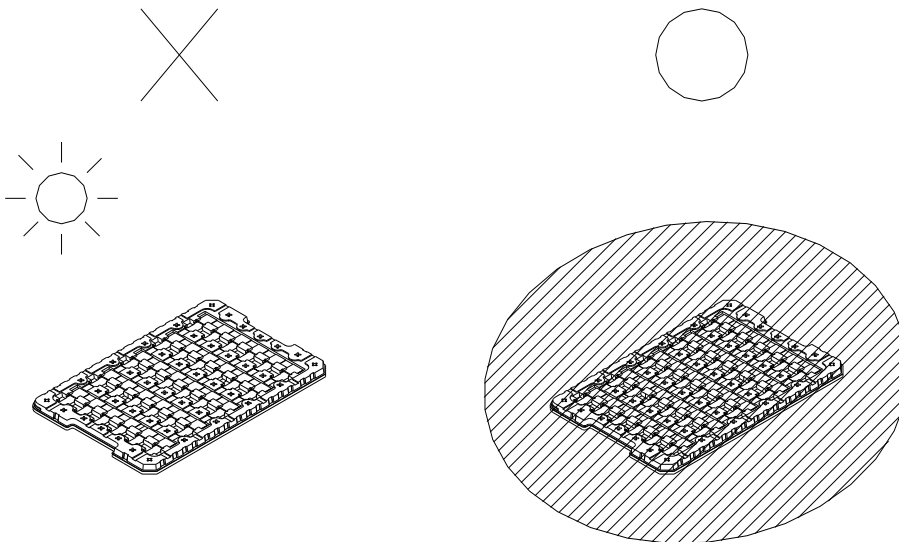

[Other Notice]

- (1) Operation outside specified environmental conditions cannot be guaranteed.
- (2) As power supply (VDD-GND, VDDA-GND) impedance is lowered during use, bus controller should be inserted near LCD module as much as possible.
- (3) Polarizer is applied over LCD panel surface. Liquid crystal inside LCD panel deteriorates with ultraviolet ray. The panel should not be left in direct sun or under strong ultraviolet ray for prolonged period of time even with the polarizer.
- (4) Disassembling the LCD module will cause permanent damage to the module. Do not disassemble the module.
- (5) If LCD panel is broken, do not ingest the liquid crystal from the broken panel. If hand, leg or clothes come in contact with liquid crystal, wash off immediately with soap. If mouth or eyes come in contact with liquid crystal, rinse with water as soon as possible, following the instructions of the appropriate MSDS.
- (6) ODS (specific chlorofluorocarbon, specific halon, 1-1-1 trichloroethane, carbon tetrachloride) are not used or contained in material or all production processes of this product.
- (7) Observe all other precautionary requirements in handling general electronic components.

Discarding liquid crystal modules

Follow the regulations when LCD module is scrapped. The government you stay may have some regulations about it.

LCD Panel : Dispose of as glass waste. This LCD module contains no harmful substances.

The liquid crystal panel contains no dangerous or harmful substances.

This liquid crystal panel contains only an extremely small amount of liquid crystal (approximately 100mg) and therefore it will not leak even if the panel should break.

Its median lethal dose (LD50) is greater than 2,000 mg/kg and a mutagenetic (Aims test: negative) material is used.

Contents

1. Scope of application.....	9
2. Outline	9
3. Features	9
4. Mechanical specification	9
5. Structure.....	10
5-1 Makeup	10
5-2 LCD-FPC performance	10
6. Input pin specification	11
7. Absolute maximum ratings	11
8. Electrical specification	12
8-1 Recommended operation range.....	12
8-2 DC electrical characteristics.....	12
8-3 Operation characteristics.....	13
8-4 Input signal characteristics.....	13
9. Recommended sequence.....	15
9-1 Power source sequence	15
9-2 Timing chart.....	16
10. Example of external circuit	20
11. Optical specification	21
11-1 Optical characteristics	21
11-2 Measurement method.....	21
12. Display quality.....	22
13. Shipping.....	23
13-1 Lot number display	23
13-2 Carton storage conditions.....	24
13-3 Packing.....	24
14. Reliability test conditions	25
14-1 Reliability test items.....	25
15. TFT-LCD module handling	26
15-1 Inserting the FPC in the connector and removing.....	26
15-2 FPC handling	26
15-3 Module handling	26
16. Other	26
Outline dimension	27

1. Scope of application

This specification applies to TFT-LCD module LS012B7DD01

2. Outline

This TFT-LCD module is an active matrix LC display (LCD: liquid crystal display) module with CG silicon (CG-Si: Continuous Grain-Silicon) and thin film transistors (TFT: Thin Film Transistor). This TFT-LCD module is such that black and white 2 value display is possible in a 184x38 dot panel.

3. Features

- Active matrix drive system
- Transflective type, black and white display with 1.17" screen. (184x38 dot structure)
- Low power consumption using pixel memory panel (normally white).
- The interface system uses serial interface (3 wire system).
- Lightweight, thin and compact.
- High reflectance (with slight transmissivity)

4. Mechanical specification

Table 4-1 Module mechanical specification table

Item	Specification	Unit
Screen size(diagonal)	2.9686[1.17"]	cm
Active display area	29.072(H)×6.004(V)	mm
Dot structure	184(H)×38(V)	Dot
Dot pitch	0.158(H) ×0.158(V)	mm
Pixel array	Square	—
Module outline dimensions (not including protruding parts)	35.1(W)×11.0(H)×0.741(D) (NB)	mm
Mass	0.6 (TYP)	g
Surface hardness	At least 3H (initial)	Pencil hardness

NB) Please refer to Figure 5-1 (Page.25) for the detailed dimensions, tolerance.

5. Structure

5-1 Makeup

This LCD module is made up of an LCD panel, polarizer (Front, Rear), LCD-FPC

The outline dimensions are shown in Figure 5-1(Page.25).

5-2 LCD-FPC performance

① Suitable connector

F.C.I. 59453-08111F 8 pin (0.5mm pitch)

② FPC flex resistance

Flexure tests are carried out with a flexure radius=R0.6mm、flexure angle =90°and there should be no breakage after less than 10 times.

③ LCD-FPC circuit diagram

The LCD-FPC circuit diagram is shown in Figure 5-2.

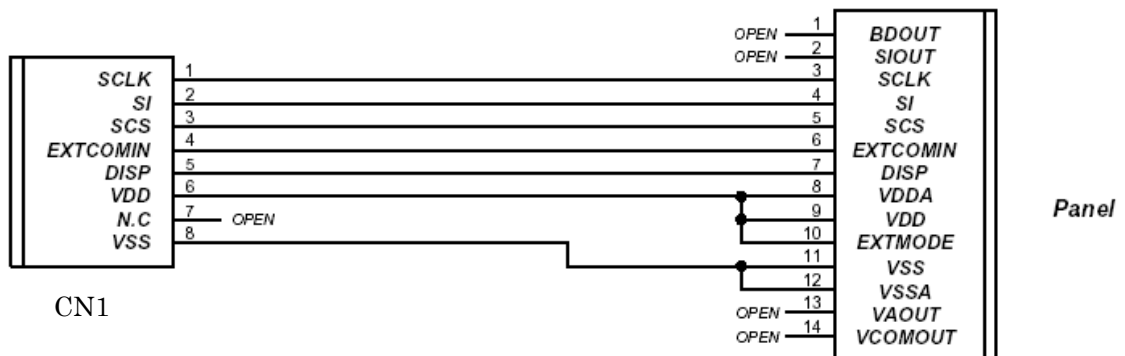

Figure 5-2 LCD-FPC circuit diagram

6. Input pin specification

Table 6-1 Input pin names

No.	Code	I/O	Voltage	Signal name
1	SCLK	I	0/3.0 (V)	Serial clock signal
2	SI	I	0/3.0 (V)	Serial input signal
3	SCS	I	0/3.0 (V)	Chip select signal
4	EXTCOMIN	I	0/3.0 (V)	COM inversion polarity input pin
5	DISP	I	0/3.0 (V)	Display ON/OFF switching signal
6	VDD	I	3(V)	Power source (logic, analog)
7	NC	—	—	—
8	VSS		0(V)	GND

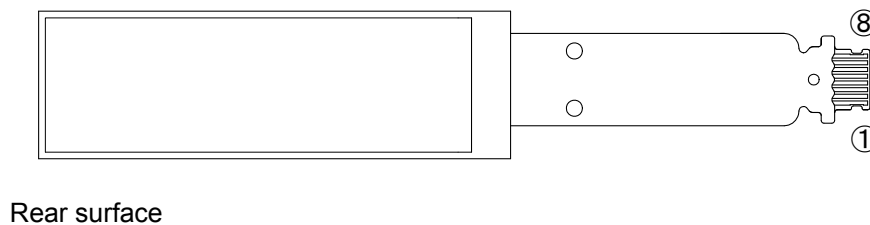
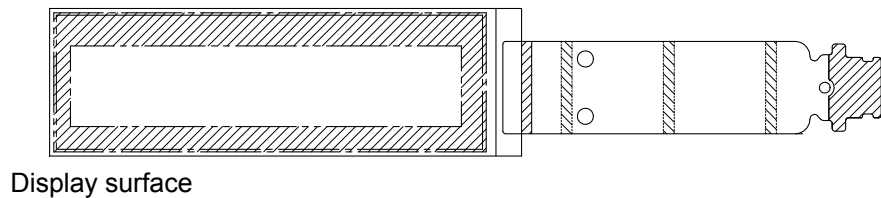

Figure 6-1 Input pin layout

7. Absolute maximum ratings

Table 7-1 Module input absolute maximum ratings

Item	Code	Rating	Unit	Notes
Supply voltage for logic	VDD	-0.3~+3.6	V	
Input signal voltage	V _{IN}	-0.3~VDD	V	(*2)
Operation temperature(panel temperature)	Topr	-10 ~ +70	°C	(*1)
Storage temperature	Tstg	-20 ~ +80	°C	(*1)

(NB) VSS pin=0V unless otherwise indicated.

(*1) Do not allow condensation.

(*2) Applies to SCS, SCLK, SI, DISP and EXTCOMIN signals.

8. Electrical specification

8-1 Recommended operation range

Table 8-1 Recommended operation range

(Ta=25°C, VSS pin=0V)

Item	Code	Conditions	Min	Typ	Max	Unit	Notes
Power supply voltage for driver	VDD		2.7	3.0	3.3	V	
Input signal voltage (High)	V _{INHI}		VDD-0.1	—	VDD	V	(*1)
Input signal voltage (Low)	V _{INLO}		VSS	—	VSS+0.1	V	(*1)

(*1) Applies to SCS, SCLK, SI, DISP and EXTCOMIN signals.

8-2 DC electrical characteristics

Table 8-2 DC electrical characteristics

(Ta=25°C, SCS, SCLK, SI, DISP, EXTCOMIN=3.0V, VDD=3.0V, VSS pin=0V)

Item	Code	Drive	Min.	Typ	Max.	Unit	Notes
Current consumption 1	P _{VDD1}	(*1)	-	2	15	μA	
Current consumption 2	P _{VDD2}	(*2)	-	63	150	μA	

(*1) The display pattern is such that there is no image update with the all black display.

SCS=SCLK=SI=L, EXTCOMIN=60Hz

(*2) The display pattern is such that there is continuous image data update with the vertical stripe (1 dot interval) display. Data update mode

SCLK=1MHz, EXTCOMIN=60Hz

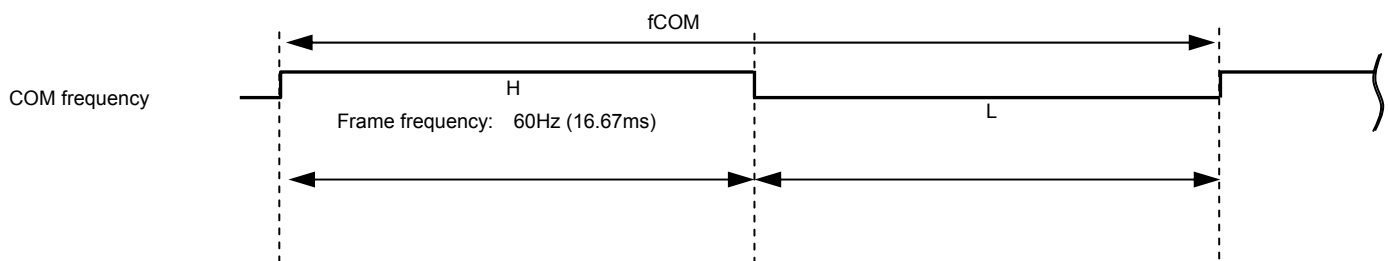

Fig A

8-3 Operation characteristics

Table 8-3 Operation signals

(Ta=25°C, SCS, SCLK, SI, DISP, EXTCOMIN=3.0V, VDD=3.0V, VSS pin =0V)

Pin name	Item	Code	Min	Typ.	Max	Unit	Notes
SCS	Frame frequency	fSCS	56	60	63	Hz	
SCLK	Clock frequency	fSCLK	-	0.5	1	MHz	
-	Vertical period	tv	15.87	16.67	17.86	msec	
-	COM frequency	fCOM	28	30	31.5	Hz	

8-4 Input signal characteristics

Table 8-4 Input signals

(Ta=25°C, SCS, SCLK, SI, DISP, EXTCOMIN=3.0V, VDD=3.0V, VSS =0V)

Pin name	Item	Code	Min	Typ.	Max	Unit	Notes
SCS	SCS rise time	trSCS			70	nsec	
	SCS fall time	tfSCS			70	nsec	
	SCS Hight width	twSCSH	232			μsec	Data update mode
			24			μsec	Display mode
	SCS Low width	twSCSL	2			μsec	
	SCS set up time	tsSCS	6			μsec	
SCS hold time	thSCS	2			μsec		
SI	SI rise time	frSI			50	nsec	
	SI rise time	trSI			50	nsec	
	SI set up time	tsSCS	250			nsec	
	SI hold time	thSI	525			nsec	
SCLK	SCLK rise time	trSCLK			50	nsec	
	SCLK fall time	tfSCLK			50	nsec	
	SCLK Hight width	twSCLKH	450	950		nsec	
	SCLK Low width	twSCLKL	450	950		nsec	
EXTCOMI N	EXTCOMIN frequency	fEXTCOMIN		60	63	Hz	(*1)
	EXTCOMIN rise time	trEXTCOMIN			70	nsec	
	EXTCOMIN fall time	tfEXTCOMIN			70	nsec	
	EXTCOMIN Hight width	twEXTCOMIN	2			μsec	
DISP	DISP rise time	trDISP			70	nsec	
	DISP fall time	tfDISP			70	nsec	

(*1) Please make the EXTCOMIN frequency less than the frame rate frequency.

Pin Name	Item	Symbol	Waveform	Notes
SCS	SCS rise time	trSCS		
	SCS fall time	tfSCS		
	SCS High width	twSCSH		
	SCS Low width	twSCSL		
	SCS set-up time	tsSCS		
	SCS hold time	thSCS		
SI	SI rise time	trSI		
	SI fall time	tfSI		
	SI Set-up time	tsSI		
	SI Hold time	thSI		
SCLK	SCLK rise time	trSCLK		
	SCLK fall time	tfSCLK		
	SCLK High width	twSCLKH		
	SCLK Low width	twSCLKL		
EXTCOMIN	EXTCOMIN rise time	trEXTCOMIN		
	EXTCOMIN fall time	tfEXTCOMIN		
	EXTCOMIN High width	twEXTCOMINH		
DISP	DISP rise time	trDISP		
	DISP fall time	tfDISP		

Figure 8-4 Input signal timing characteristics diagram

9. Recommended sequence

9-1 Power source sequence

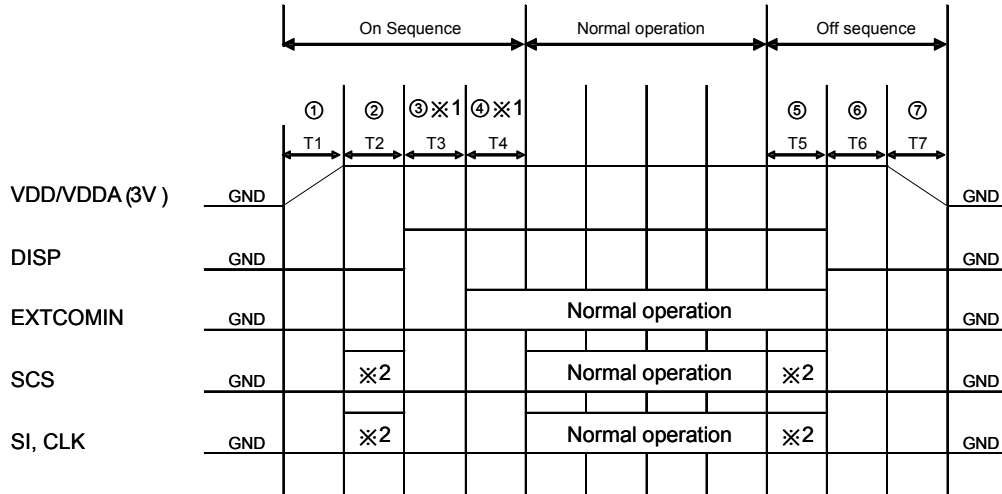

※ Refer to timing chart and AC timing characteristics for detail

※ 1. (3) and (4) may be opposite (however, TCOM polarity inversion will not occur even with EXTCOMIN between DISP="L". Also, when DISP and EXTCOMIN are simultaneously started up, allow 30us or more before SCS starts up (It may be less than 60us).

※ 2. Setting value for pixel memory initialization

SCS=Driving accordingly to clear pixel internal memory method (use all clear flag or write all screen white)

S1=M2 (all clear flag) = "H" or write white

SCLK: Normal Driving

[ON Sequence]

(1) 3V rise time (depends on IC)

(2) Pixel memory initialisation.

T2: at least 1 frame.

Use M2 (all clear flag) to initialise (at least once). Or write whole screen white.

(3) Release time for initialisation of TCOM latch T3: 30us or more

Time required to release COM latch circuit which is initialized using DISP signals

(4) TCOM polarity initialisation time T4: 30us or more

Time required initialising TCOM polarity accordingly to EXTCOMIN input

[Normal Operation]

Duration of normal driving

[Off Sequence]

(5) Pixel memory initialisation time T5: at least 1 frame

(6) VCOM initialisation time T6: 30us or more

(7) 3V falling time (Depends on IC)

NB: Please contact Sharp before changing this sequence.

9-2 Timing chart

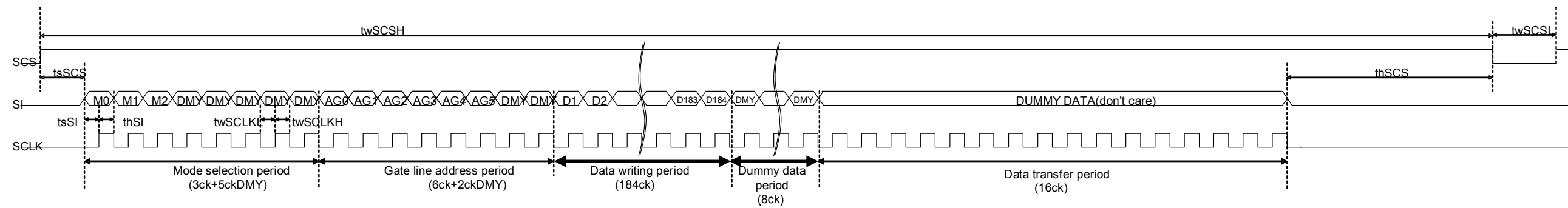

M0: Mode flag. Set for "H". Data update mode (Memory internal data update)

When "L", display mode (maintain memory internal data).

M1: It can be "H" or "L".

M2: All clear flag.

All Clear Mode, set to "L". Refer to 'All clear timing chart'

D1-D184: Image data. "L" = black display. "H" = white display.

DUMMY DATA: Dummy data. It can be "H" or "L" ("L" is recommended.)

※ Data write period
Data is being stored in 1st latch block of binary driver on panel.
※ Data transfer period
Data written in 1st latch is being transferred (written) to pixel internal memory circuit.

Gate line address selection table

GL	AG0	AG1	AG2	AG3	AG4	AG5
1	1	0	0	0	0	0
2	0	1	0	0	0	0
3	1	1	0	0	0	0
4	0	0	1	0	0	0
5	1	0	1	0	0	0
6	0	1	1	0	0	0
7	1	1	1	0	0	0
8	0	0	0	1	0	0
:	:	:	:	:	:	:
31	1	1	1	1	1	0
32	0	0	0	0	0	1
33	1	0	0	0	0	1
34	0	1	0	0	0	1
35	1	1	0	0	0	1
36	0	0	1	0	0	1
37	1	0	1	0	0	1
38	0	1	1	0	0	1

Data Update Mode (Multiple Lines)

Updates arbitrary multiple lines data. (M0="H", M2="L")

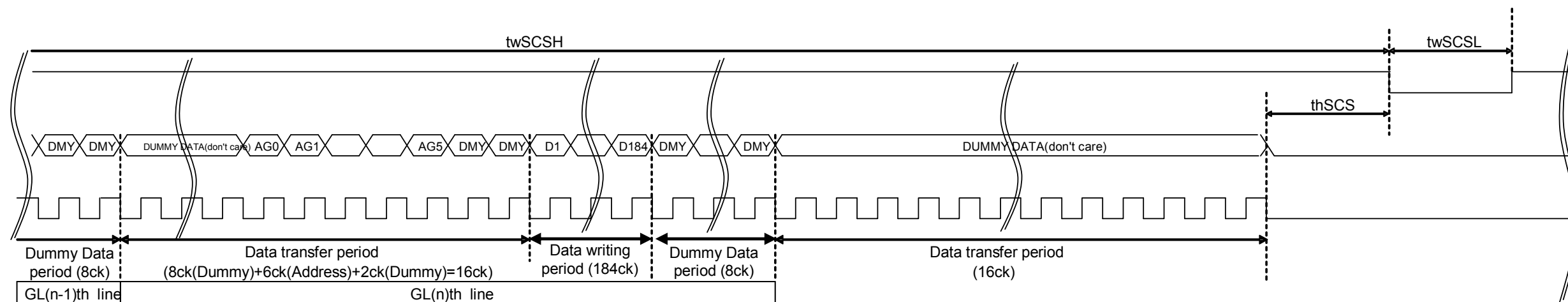
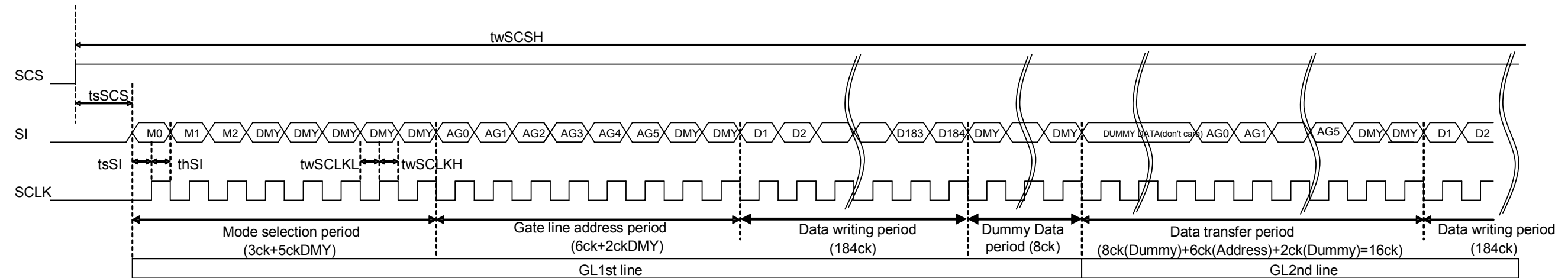

M0: Mode flag. Set for "H". Data update mode (Memory internal data update)

When "L", display mode (maintain memory internal data).

M1: It can be "H" or "L".

M2: All clear flag.

All Clear Mode, set to "L". Refer to 'All clear timing chart'

D1-D184: Image data. "L" = black display. "H" = white display.

DUMMY DATA: Dummy data. It can be "H" or "L" ("L" is recommended.)

- ※ Data write period
Data is being stored in 1st latch block of binary driver on panel.
- ※ Data transfer period
For example, during GL2 line data transfer period, GL 2nd line address is latched and GL 1st line data is transferred from 1st latch to pixel internal memory circuit at the same time.

Display Mode

Maintains memory internal data (maintains current display). (M0="L", M2="L")

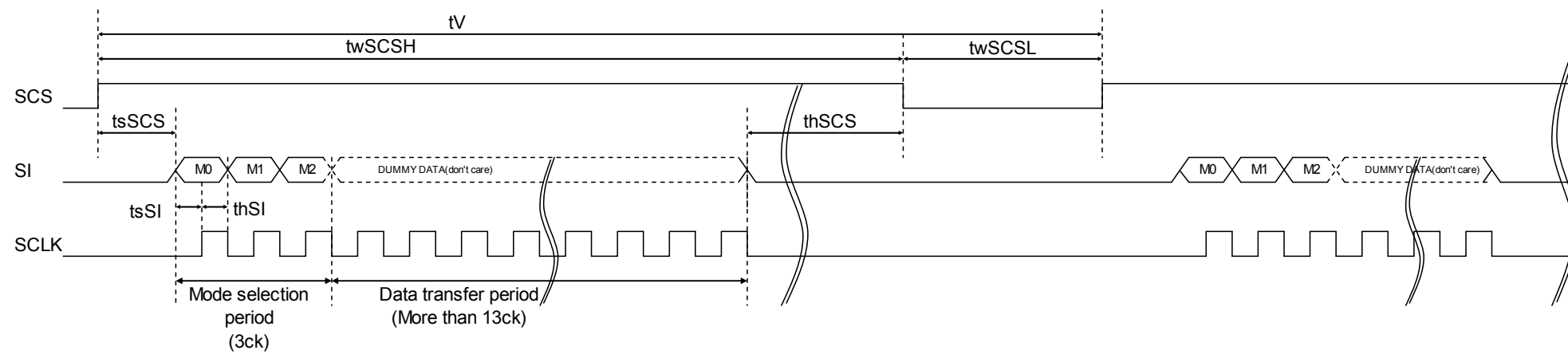

M0: Mode flag.

When "L", display mode (maintain memory internal data).

Set for "H". Data update mode (Memory internal data update)

M1: It can be "H" or "L".

M2: All clear flag.

All Clear Mode, set to "L". Refer to 'All clear timing chart'

DUMMY DATA: Dummy data. It can be "H" or "L" ("L" is recommended.)

All Clear Mode

Clears memory internal data and writes white. (M0="L", M2="H")

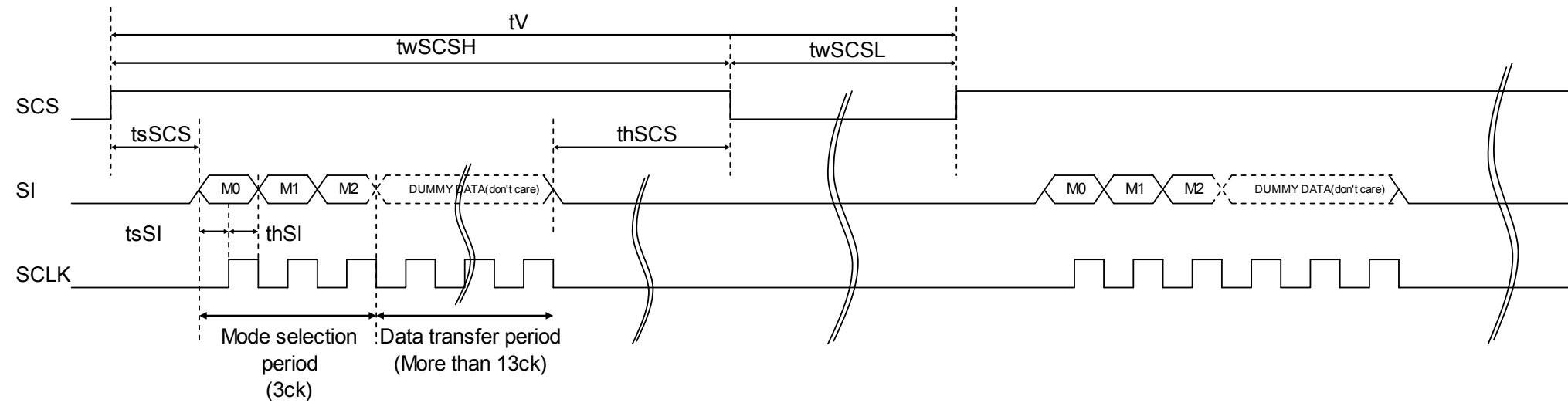

M0: Mode flag.

Set it "L".

M1: It can be "H" or "L".

M2: All clear flag.

Set it "H"

DUMMY DATA: Dummy data. It can be "H" or "L" ("L" is recommended.)

COM Inversion

EXTCOMIN has 2 timing conditions:

(1): The EXTCOMIN input during high period of the SCS signal

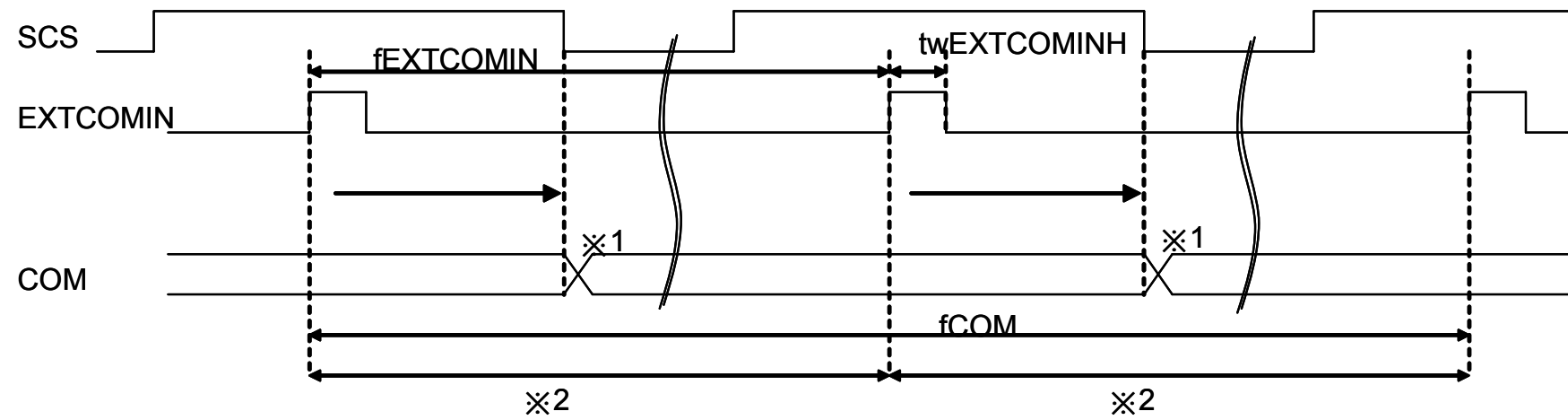

※ 1: LC inversion polarity has been set by the falling edge of SCS signal.

※ 2: The period of EXTCOMIN should be constant.

(2): the EXTCOMIN input during low period of the SCS signal

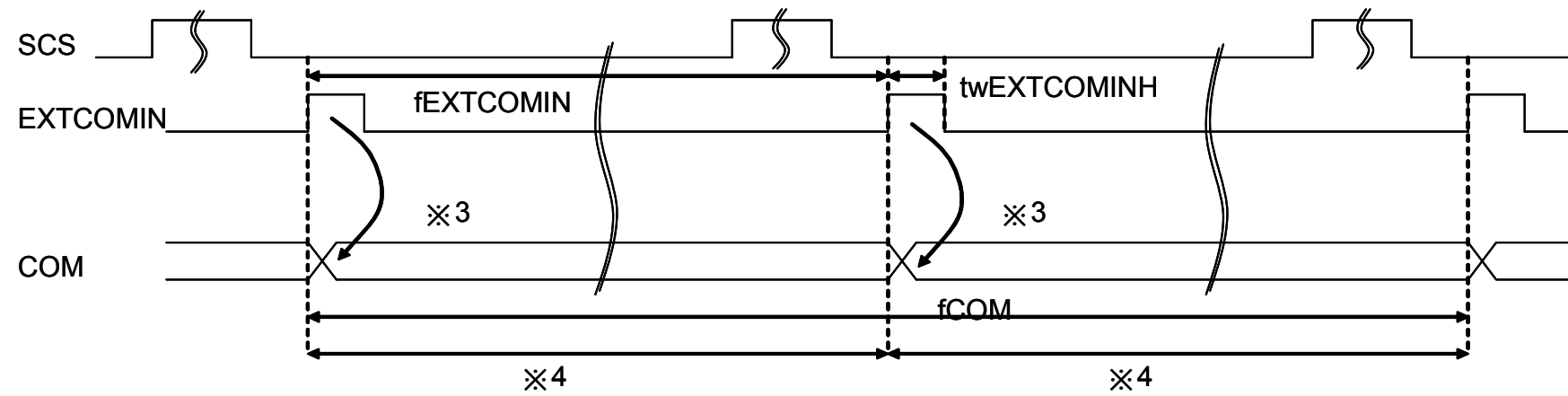

※ 3: LC inversion polarity has been set by the rising edge of EXTCOMIN.

※ 4: The period of EXTCOMIN should be constant.

10. Example of external circuit

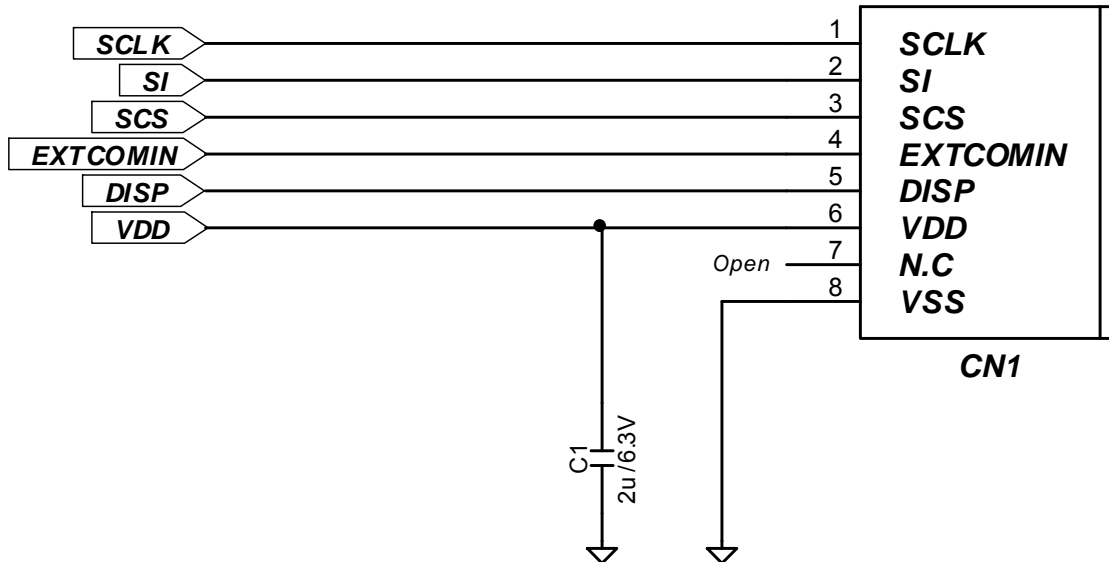

*Above circuit and parts are only recommendation

For actual use, please evaluate their conformity with your system and design.

(Capacitor pressure resistance can be larger than resistance indicated above.)

Figure 10-1 External circuit diagram (recommended)

11. Optical specification

11-1 Optical characteristics

(a) Reflection characteristics

Table 11-1: Reflection optical characteristics

(Ta = 25°C)

Item	Code	Conditions	Min	Typ	Max	Unit	Notes
Reflectance		$\theta=0^\circ$	12	15	—	%	11-2(b),(e)
Contrast ratio	CR	$\theta=0^\circ$	18	22	—	—	11-2(c),(e)
Viewing angle	θ_{11}	$Co \geq 2$	50	60	—	degrees	11-2(a),(d)
	θ_{12}		50	60	—		
	θ_{21}		50	60	—		
	θ_{22}		50	60	—		
Chromaticity	White	W_x	—	0.31	—	-	11-2(e)
		W_y	—	0.33	—		
Transmissivity		$\theta=0^\circ$		0.25	—	%	

11-2 Measurement method

(a) The viewing angle direction is defined as shown below.

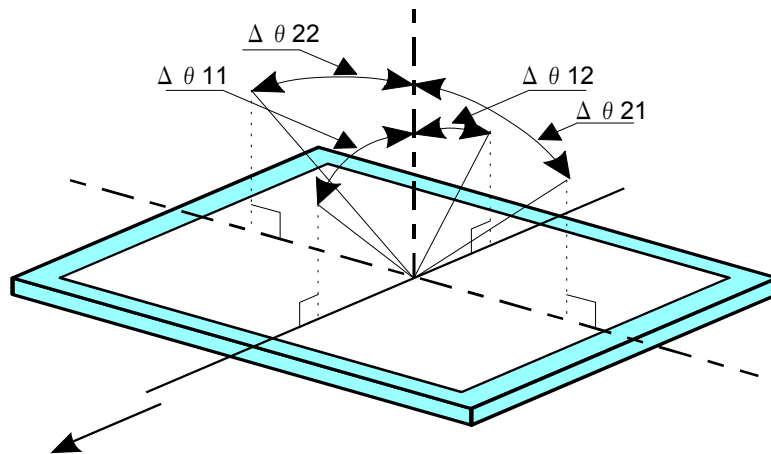

Figure 11-1 Definition of viewing angle direction

(b) Reflectance is defined as shown below.

$$\text{Reflectance} = \frac{\text{Reflected luminance of white display}}{\text{Reflected luminance of calibrated diffuse white standard}}$$

(c) The reflection contrast ratio is defined with the following equation.

$$\text{Reflection contrast ratio} = \frac{\text{Reflected luminance of white display}}{\text{Reflected luminance of black display}}$$

(d) Reflection Viewing angle

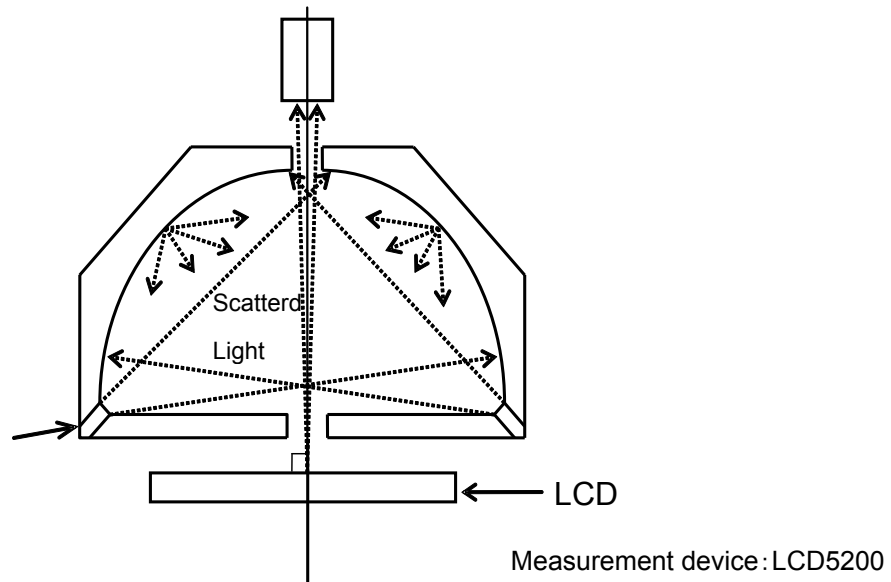

Figure 11-2 Reflection mode viewing angle measurement method

(e) Reflection Reflectance/contrast /chromaticity

-Measured with Minolta spectrophotometer CM2002.

-Based on light source (D65).

12. Display quality

The standard for LCD module display quality is based on the shipping inspection standards.

13. Shipping

13-1 Lot number display

Displayed by printing. The display position is shown in Figure 13-1 outline dimension diagram.

Incjet print contests:

Line 1 → YMDDP
Line 2 → 01234A

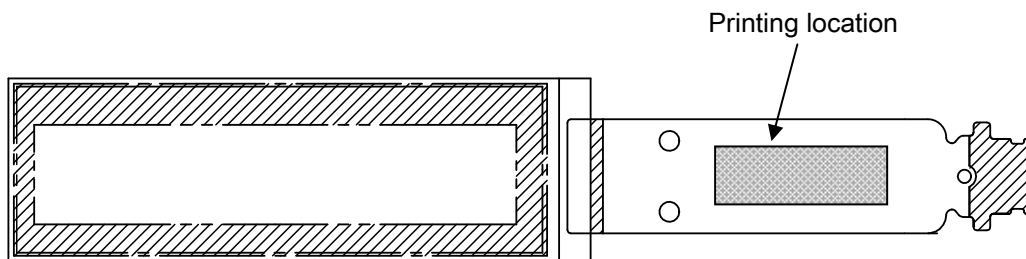

Figure 13-1 Lot number printing position

Table 13-1 marking line definition

Line	Making	Description
1	YMDDP	Y : Single-digit year (Last digit of the year) (0,1,- - 8,9) M : Single-digit Month (1,2,--,9,X,Y,Z) DD : Digit of the day (01,--,31) P : Code of manufacture
2	01234A	01234 : Five-digit in Consecutive number (Traceability number) A : Product revision

13-2 Carton storage conditions

- 1) Piling number of cartons. : 7
- 2) Package quantity in one carton : 1600 pcs
- 3) Carton size (Typ.) : 578mmx382mmx255mm
- 4) Carton store environment:

- Temperature:

0~40°C

- Humidity:

60%RH or lower (at 40°C)

There should be no condensation at low temperature and high humidity.

- Atmosphere:

No harmful gas, such as acid or alkali, which causes severe corrosion on electronic parts and wiring, are to be detected.

- Opening the package:

In order to prevent electrostatic damage to TFT modules, room humidity should be made over 50%RH and take effective measure such as use of earth when opening the package.

- Direct sunlight

Please keep the product in a dark room or cover the product to protect from direct sunlight.

- Atmospheric condition

Please refrain from keeping the product with possible corrosive gas or volatile flux.

- Prevention of dew

Do not place directly on the floor, and please store the product carton either on a wooden pallet or a stand to avoid dew condensation. In order to obtain moderate ventilation in the pallet's bottom surfaces, arrange correctly in the fixed direction.

Please place the product cartons away from the storage wall. Be careful of the inside of a warehouse to ventilate well and please consider installation of a ventilator.

Manage to rapid temperature change under natural environment.

- Vibration

Please refrain from keeping the product in the place which always has vibration.

- Storage Period:

Within above mentioned conditions, maximum storage period should be 3 months

13-3 Packing

The packing method is shown in Figure 13-2(P28).

The packaging is designed such that the module does not break during transit.

14. Reliability test conditions

14-1 Reliability test items

Table 14-1 Reliability test items

	Test items	Test contents		Notes
1	High temperature storage	Ta=80°C	240h (Non-operating)	
2	Low temp. storage	Ta=-20°C	240h (Non-operating)	
3	High temp. high humidity operation	Tp=40°C /95%RH	240h	
4	High temp. operation	Tp=70°C	240h	
5	Low temp. operation	Tp=-10°C	240h	
6	Thermal shock	Ta=-20°C (1h)~+70°C (1h)/cycle= 5cycles (Non-operating)		
7	Electrostatic resistance	±200V,200pF(0Ω) Once each pin		

【NB】Ta=ambient temperature, Tp=panel temperature

(Evaluation method)

In the standard condition, there shall be no practical problems that may affect the display function.

15. TFT-LCD module handling**15-1 Inserting the FPC in the connector and removing**

When inserting the FPC in the connector and then when removing, be sure to turn the set side power OFF.

15-2 FPC handling

(1) The fold of the FPC (R) should be at least 0.6mm and R should be uniform.

Please do not fold the FPC towards the front polarizer side in the connection part with the LCD panel.

(2) Please do not hold the FPC and swing the LCD module or apply too much strength to the FPC.

15-3 Module handling

(1) When adhering the module to a device, contact with the driver or conductive part of the substrate can cause electrical In leakage.

(2) When attaching, please fix such that it is on the same level and make sure there is no stress such as warping or twisting on the module. When pressing the LCD surface after embedding, please take care that excess mechanical stress is not applied to the LC module.

(3) In a set design that has no protective sheet in the panel front part for reducing surface reflection, when static electricity is applied to the panel peripheral part, there is the risk of electrostatic damage of the module so please design such that it is surrounded by the set cabinet up to the peripheral part of the polarizer and such that a conductive sheet or the like grounded to the rear side thereof is adhered to absorb static electricity. (Refer to Figure 15-1)

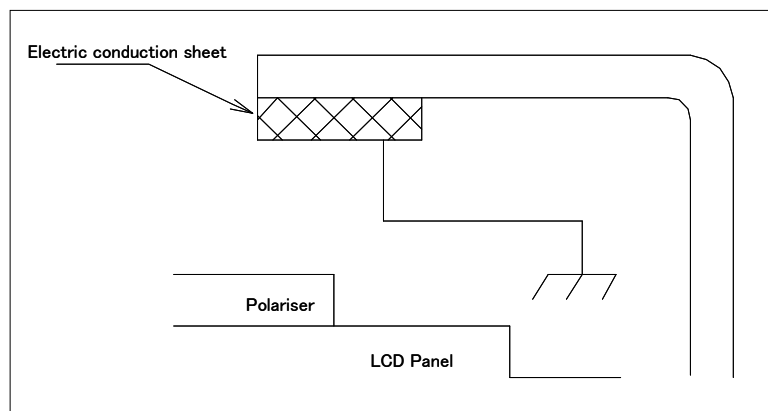
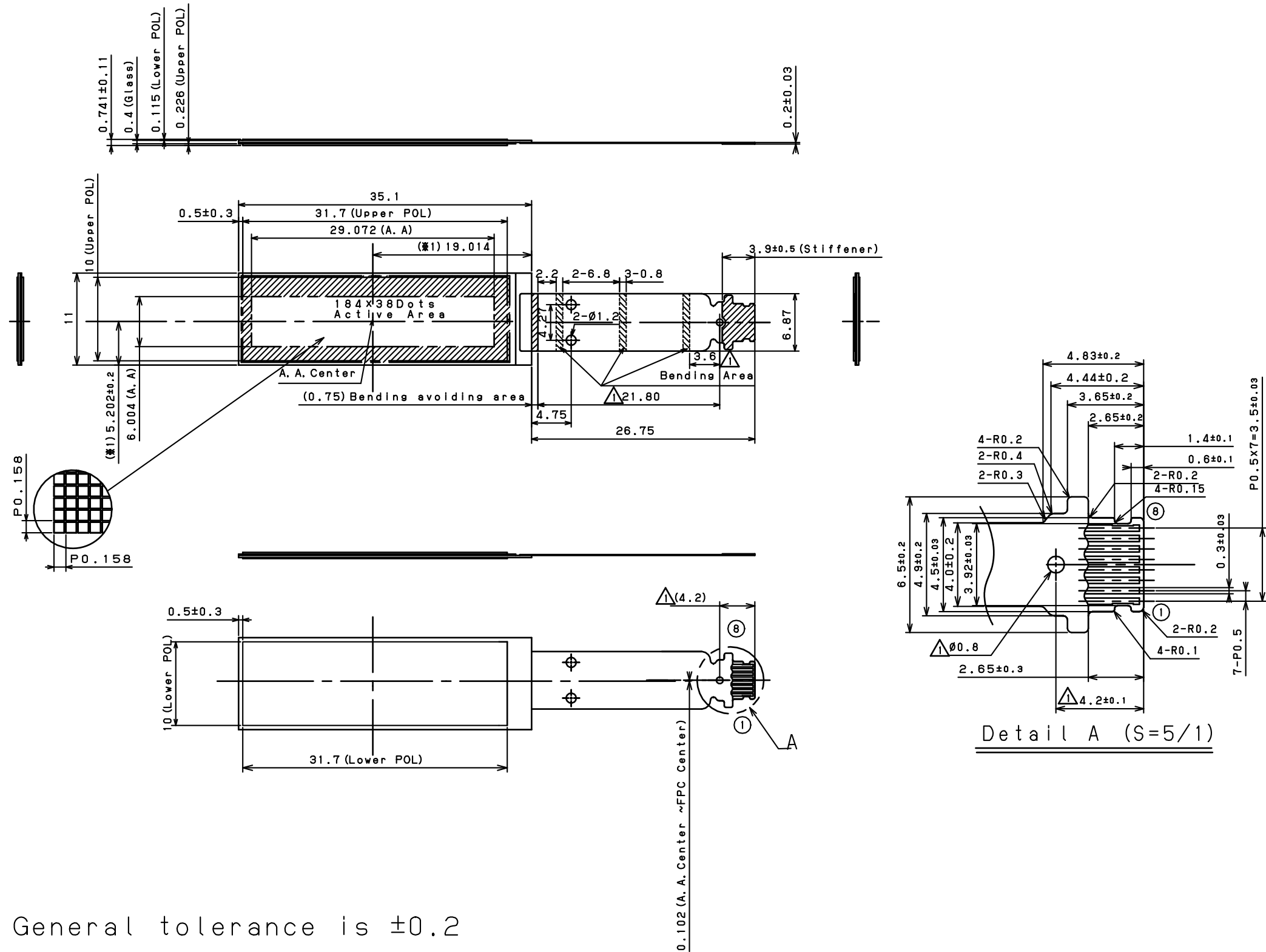

Figure 15-1 Design example

16. Other

If any problems occur with the Sharp specification items or any other items, efforts will be made to improve in cooperation. When making any changes that are likely to have a significant effect on the quality and reliability, advance contact will be made to gain approval.

Outline dimension



General tolerance is ±0.2

Figure 5-1 Outline dimensions diagram

[Packaging]
 40 modules/1 tray (There are 20 pockets in a tray and 2 modules go into one pocket.)
 400 modules/1bag (Ten trays containing 40 modules are contained in one bag.)

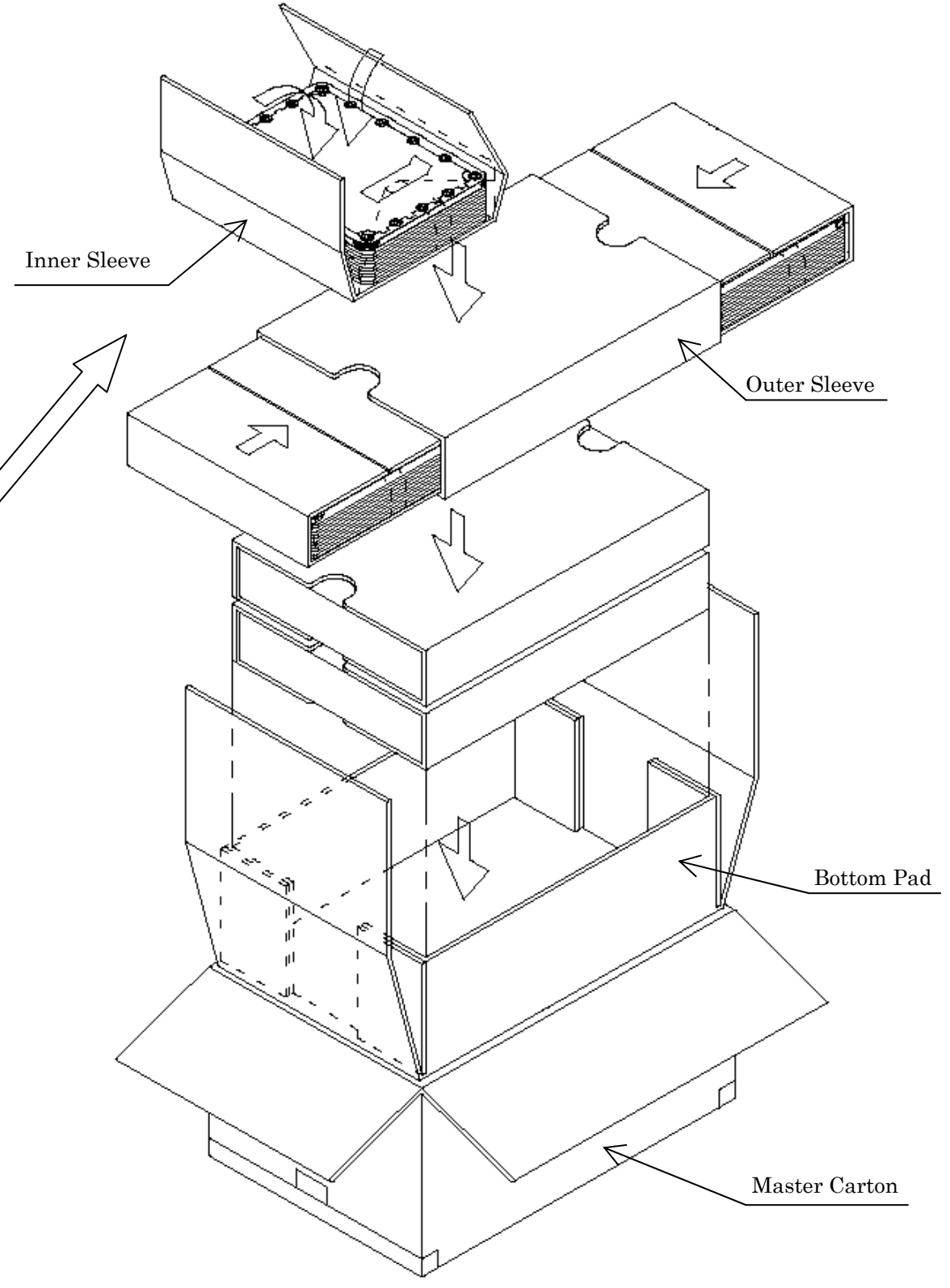
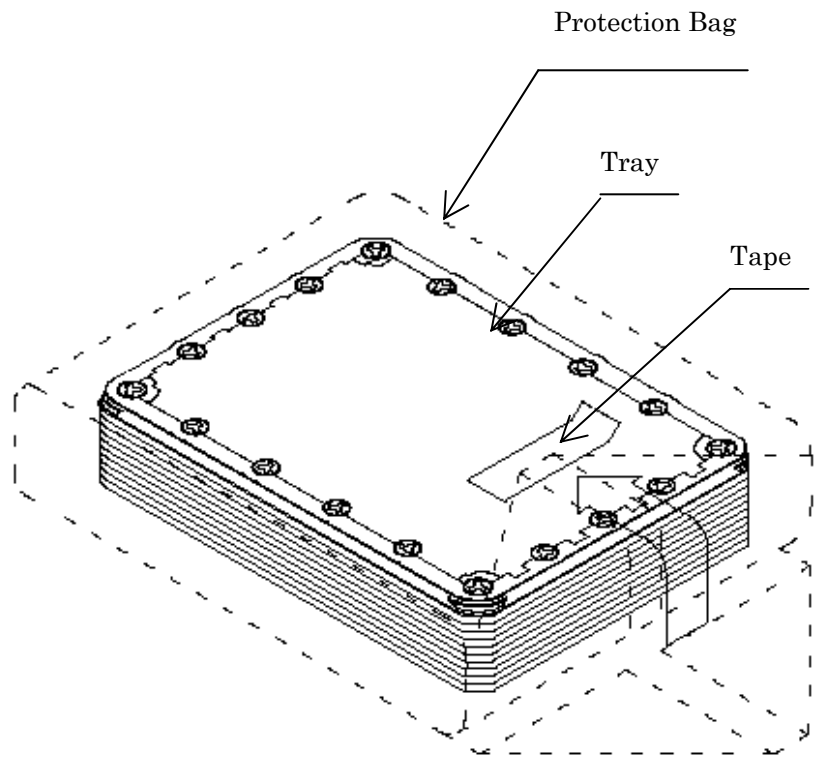

[Module] 400Pcs/bag × 4 = 1,600pcs/Carton

Figure 13-2 Packing