



## Dry Contact Relay Kit

### RELAYCARD-SDU



## Instruction Manual



# Contents

What's Included .....	4
Installation .....	4
Product Description .....	5

While every precaution has been taken to ensure accuracy and completeness in this manual, EGS Electrical Group, LLC. assumes no responsibility, and disclaims all liability for damages resulting from use of this information or for any errors or omissions.

The SolaHD and Emerson logos are registered in the U.S. Patent and Trademark Office. All other product or service names are the property of their registered owners.

©2011 EGS Electrical Group, LLC. All rights reserved. Specifications are subject to change without notice.

## What's Included

- One dry contact relay box
- One interface cable (DB-9 connector)
- One 12 V dc power interconnection cable
- Four M3 mounting screws

## Installation

### **DANGER!**

**Only qualified personnel should install or service this system. Electrical safety precautions must be followed when installing or servicing this equipment. To prevent risk of electrical shock, turn off and lock out all power sources to the unit before making electrical connections.**

1. Using the four M3 screws provided, mount the dry relay box on the right side of the SDU UPS. If mounting on a separate chassis, the hole diameter for the relay box is 0.378 in. (3.5 mm).
2. Plug the 12 V dc power interconnection cable into the 12 V dc input (Vin) of the relay box. Plug the other end of the power interconnection cable into the aux dc output (or Vout) of the SDU UPS.
3. Plug the DB-9 connector cable into the RS232 communication port of the SDU UPS. Plug the other end of the connector into the remote port of the dry contact relay.

# Product Description

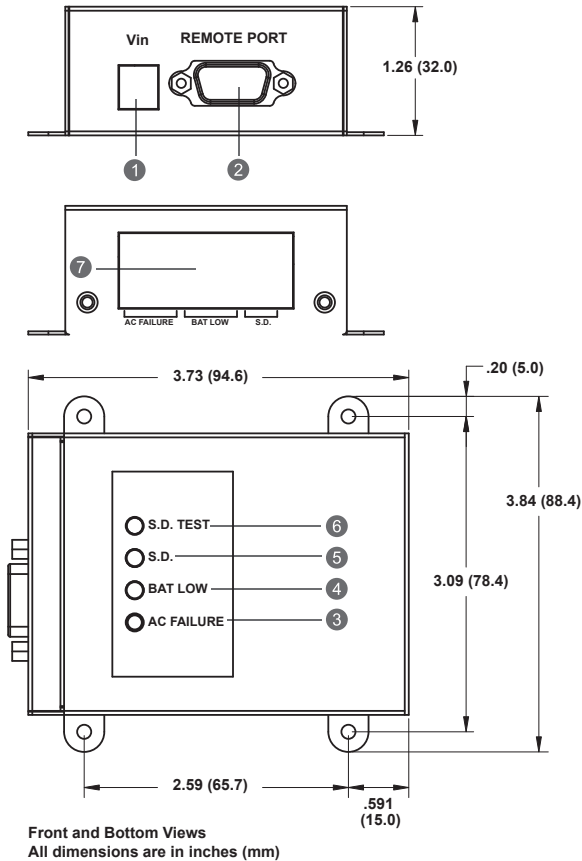

1. **Vin:** Input connector used to provide the dry contact relay with 12 V dc input power.
2. **Remote Port:** This communication port is used for linking to the SDU UPS.  
**NOTE:** The provided connection cable is used only for this dry contact relay.
3. **AC Failure Indicator:** This yellow LED is illuminated when ac voltage is abnormal.
4. **Battery (Bat) Low Indicator:** This green LED is illuminated when battery capacity is low.
5. **Shut Down (S.D.) Indicator:** When the dry contact relay receives the shut down signal for 1 second, the red LED is illuminated and the SDU UPS goes into shut down mode.

**6. Shut Down (S.D.) Test Button:** Provides the dry contact relay a shut down signal (to test the shut down function) when the UPS is operating in the battery mode. Push this button for 1 second and the red LED is illuminated. The SDU UPS goes into shut down mode after 3 minutes.

**7. Eight Pole Terminal Blocks:**

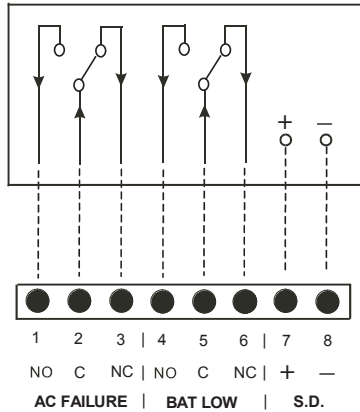

Table 1: Terminal Blocks—Layout & Operation									
+UPS State		External Input	DCB LED Display			Terminal Blocks			
O = Occur X = Does not occur		O = Enable X = Disable	O = LED On X = LED Off			O = Close X = Open			
AC Failure	BAT Low	S.D.	Yellow	Green	Red	Pin 1-2	Pin 2-3	Pin 4-5	Pin 5-6
X	X	X	X	X	X	X	O	X	O
O	X	X	O	X	X	O	X	X	O
O	O	X	X	O	X	O	X	O	X
O	X	O	X	X	O	X	O	X	O

**NOTES:**

- Suitable electric wire: 22–12 AWG (IEC 2.5 mm)
- Contact maximum current: 1.0 A @ 250 V ac
- Shut down input signal (range = +5 V to +12 V) can be provided by enabling terminals 7 and 8 for remote shut down control using an external remote device



# SOLAHD

[www.solahd.com](http://www.solahd.com)  
(800) 377-4384 • (847) 268-6651  
[solahd.technicalservices@emerson.com](mailto:solahd.technicalservices@emerson.com)



**EMERSON**  
Industrial Automation

Part Number: A272-081 Rev 9  
April 2011