

DWG. NO.
S99544

THIS DRAWING IS A CONTROLLED DOCUMENT FOR SOURIAU USA, INC. IT IS SUBJECT TO CHANGE WITHOUT NOTIFICATION. CONTACT THE DOCUMENT CONTROL CENTER FOR THE LATEST REVISION.

THE INFORMATION CONTAINED IN THIS DRAWING IS CONFIDENTIAL AND MAY NOT BE DISCLOSED WITHOUT WRITTEN CONSENT FROM SOURIAU USA, INC.

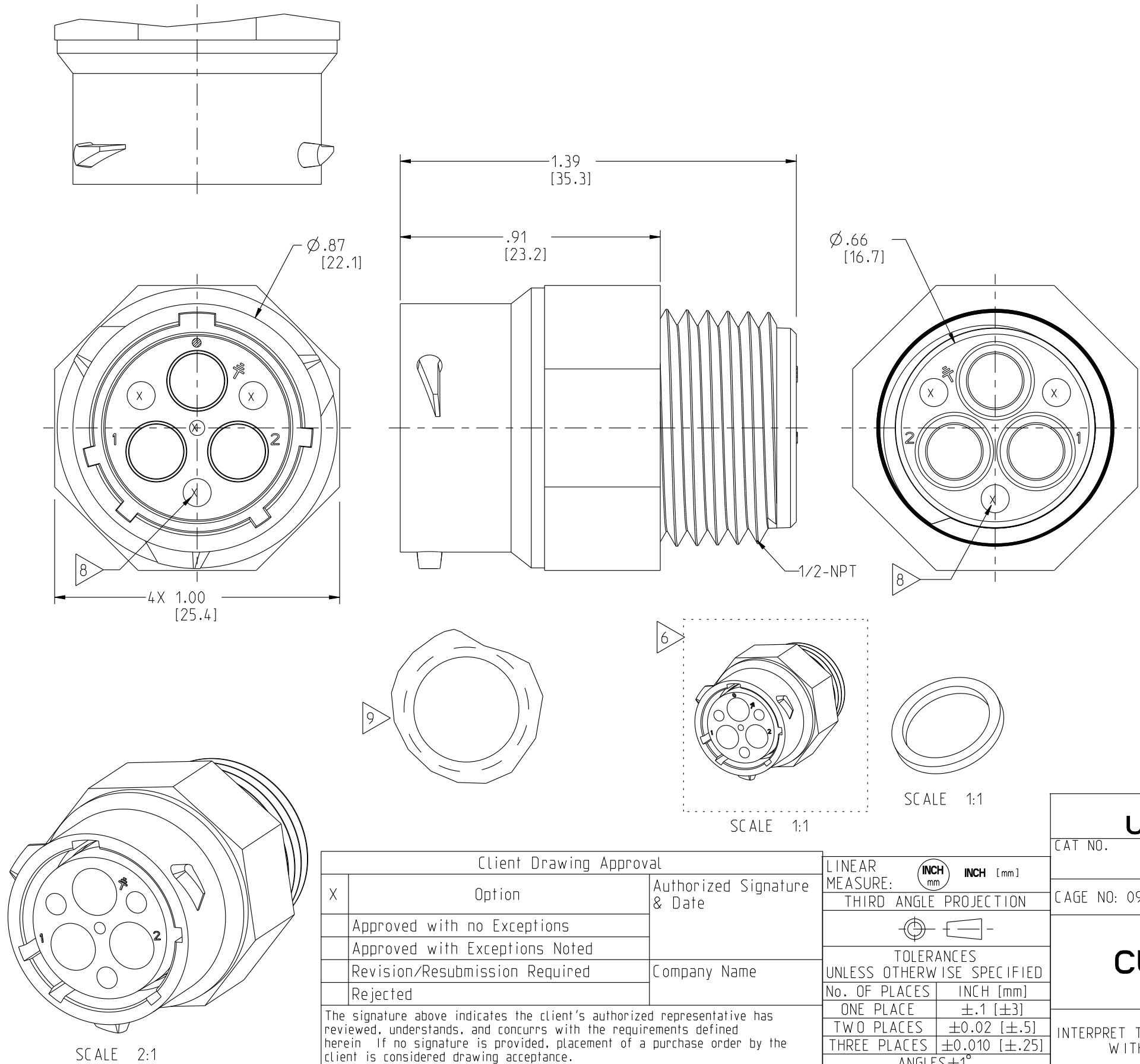

NOTES:

1. MATES WITH UTS6_ _142G1P.
2. USES 1-TO-3 EA. SIZE-8 SOCKET (CONTACTS ORDERED SEPARATELY)
CONTACT TYPE: 829116____: REFER TO SOURIAU BSD202333002.
3. MATERIALS
 - 3.1 HOUSING: POLYAMIDE UL94V0, COLOR-BLACK.
 - 3.2 ALL MATERIALS ARE RoHS COMPLIANT.
4. PRODUCT PERFORMANCE.
 - 4.1 OPERATING TEMPERATURE: -40°C TO 105° C.
 - 4.2 CORROSION: SALT SPRAY, 500 HOUR.
 - 4.3 DURABILITY: 250 MATE-UNMATE CYCLES.
 - 4.4 SEALING: WHEN MATED TO CABLE PLUG (NOTE-1):
IEC 60529-IP68: 10m WATER, 1-WEEK;
-IP69K: HIGH-PRESSURE WATER, DIN 40050.
 - 4.5 TYPICAL INSTALLATION: OUTLET BOX.
RECOMMENDED TOOLS: 8-POINT 1 INCH SOCKET; MAX. TORQUE 37 in.-lb.
5. ELECTRICAL PERFORMANCE
 - 5.1 DIELECTRIC WITHSTANDING VOLTAGE / INSULATION RESISTANCE.
2200 VRMS MAX. BETWEEN CIRCUITS / 5000 MOhm MIN. @ 500 VDC.
 - 5.2 OPERATING VOLTAGE: 600 VAC MAX.
 - 5.3 CIRCUIT USE:

CIRCUIT	USE
1	44-AMP MAX.
2	
X	GROUND, NO CURRENT FIRST MATE LAST BREAK

- 6 PACKAGING: 1 EA. RECEPTACLE PER RESEALABLE PLASTIC BAG.
RUBBER WASHER IS BULK-PACKAGED.
LABEL ON SHIPPING CONTAINER INCLUDES SOURIAU P/N & QTY.
7. UL1977 RECOGNIZED.
- 8 MOLDING "VOID CORES" ARE INDICATED "X".
- 9 PANEL CUTOUT IF APPLICABLE: TAP DRILL 23/32 OR .719 INCH (18.3mm).
NPT-1/2 THREAD.

B	RELEASED PER ECN 11721	RSK 05-16-12	NPP 05-16-12
A	RELEASED PER ECN 11483	RSK 08-11-11	NPP 08-11-11
REV	DESCRIPTION	BY DATE	CHKD DATE

DRAWING TITLE
UTS RECEPTACLE, SIZE-14, NPT-1/2

CAT NO. **UTS7142G1SNPT**

CAGE NO: 09922 SIZE: B

CUSTOMER

INTERPRET THIS DRAWING IN ACCORDANCE WITH ASME Y14.5M - 1994.



SOURIAU
Connection Technology

www.souriau.com

APPROVAL

DRAWN:	NP	4/19/10
CHKD :	-	-
DSGN :	NP	4/19/10
MFG :	DH	4/19/10
QC :	BB	4/19/10
DRAWING SCALE: 5:2		
DRAWING NO.		REV
S99544		B
1 OF 1		

Client Drawing Approval											
X	<table style="width: 100%; border-collapse: collapse;"> <tr> <td style="width: 60%; text-align: center;">Option</td> <td style="width: 40%; text-align: center;">Authorized Signature & Date</td> </tr> <tr> <td style="text-align: center;">Approved with no Exceptions</td> <td></td> </tr> <tr> <td style="text-align: center;">Approved with Exceptions Noted</td> <td></td> </tr> <tr> <td style="text-align: center;">Revision/Resubmission Required</td> <td style="text-align: center;">Company Name</td> </tr> <tr> <td style="text-align: center;">Rejected</td> <td></td> </tr> </table> <p style="font-size: 0.8em;">The signature above indicates the client's authorized representative has reviewed, understands, and concurs with the requirements defined herein. If no signature is provided, placement of a purchase order by the client is considered drawing acceptance.</p>	Option	Authorized Signature & Date	Approved with no Exceptions		Approved with Exceptions Noted		Revision/Resubmission Required	Company Name	Rejected	
Option	Authorized Signature & Date										
Approved with no Exceptions											
Approved with Exceptions Noted											
Revision/Resubmission Required	Company Name										
Rejected											

LINEAR MEASURE: $\frac{INCH}{mm}$ INCH [mm]

THIRD ANGLE PROJECTION

TOLERANCES
UNLESS OTHERWISE SPECIFIED

No. OF PLACES	INCH [mm]
ONE PLACE	$\pm .1$ [± 3]
TWO PLACES	± 0.02 [$\pm .5$]
THREE PLACES	± 0.010 [$\pm .25$]

ANGLES $\pm 1^\circ$