

Mass (g)	Area (mm <sup>2</sup> )	Volume (mm <sup>3</sup> )
147,98	54341	94437

UTS 6 JC 20 HYB -- N --

6 : Plug

JC : with Backshell

Size shell : 20 only

Hybrid connector

Insert Arrangement :  
 MP : optical contact MPO  
 MU : optical contact MU

Polarisation : N only

Packaging:  
 " " : x1  
 B : x100

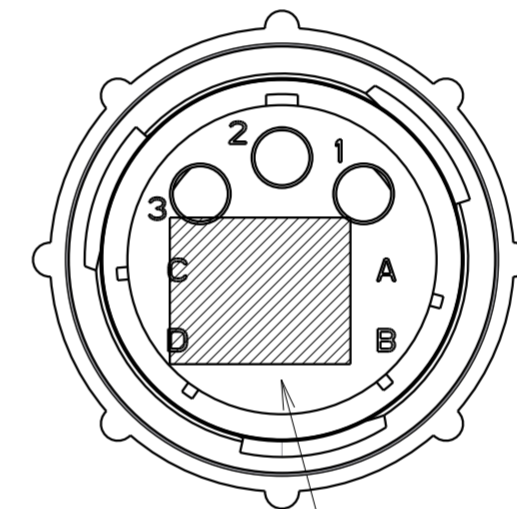
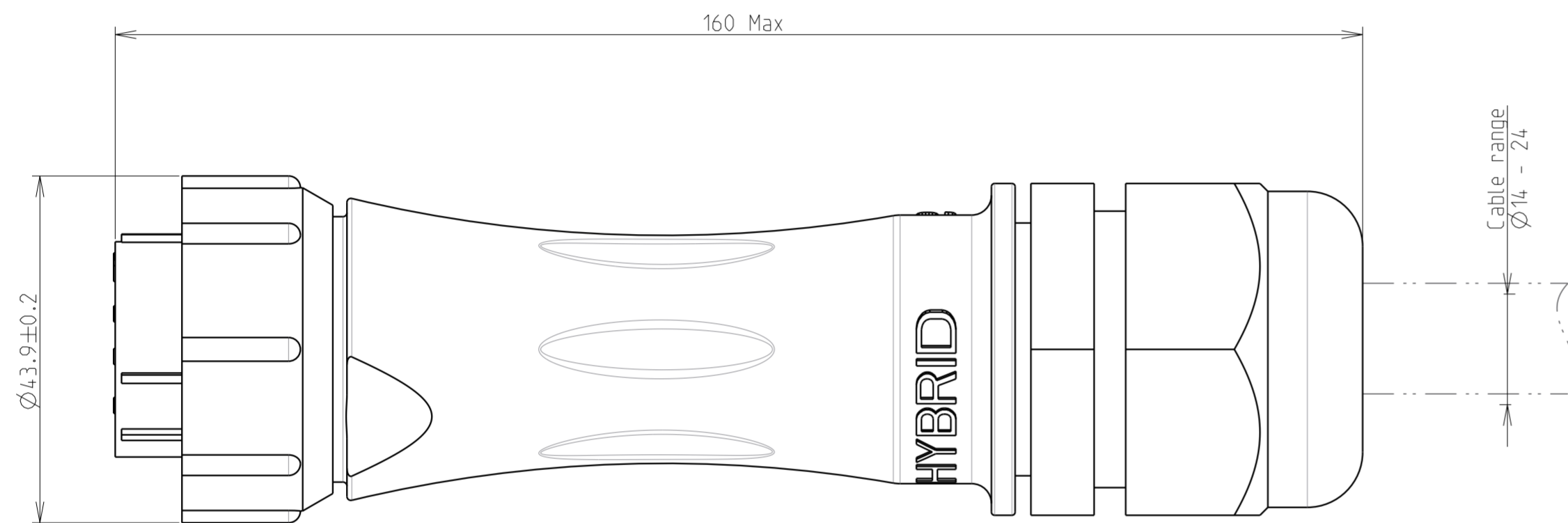

See insert arrangement

QUALITY REQUIREMENTS:

Supply requirements:  
--

Lots type:  
Only one material batch, but several Work Order accepted for a delivery

Traceability:  
Part number piece + Revision piece + SOURIAU Order Number or Work-Order + Delivery date + Quantity + Supplier Batch Number must allow to find the material certificate the process used, the date of manufacture the quantity manufactured on this batch and the recordings of the quality results

Delivery conditions:  
Delivery in bulk while guaranteeing characteristic dimensional and mechanic of straight backshell

Technical requirements:  
--

- 1-Pm = Dimension for information only
- 2-N = Dimension from Industry Standard
- 3-M = Critical Dimension
- 4-(...)= Limits acceptable for part qualification

FOR INFORMATION

Country	Jurisdiction & Control List
FR	NOT LISTED

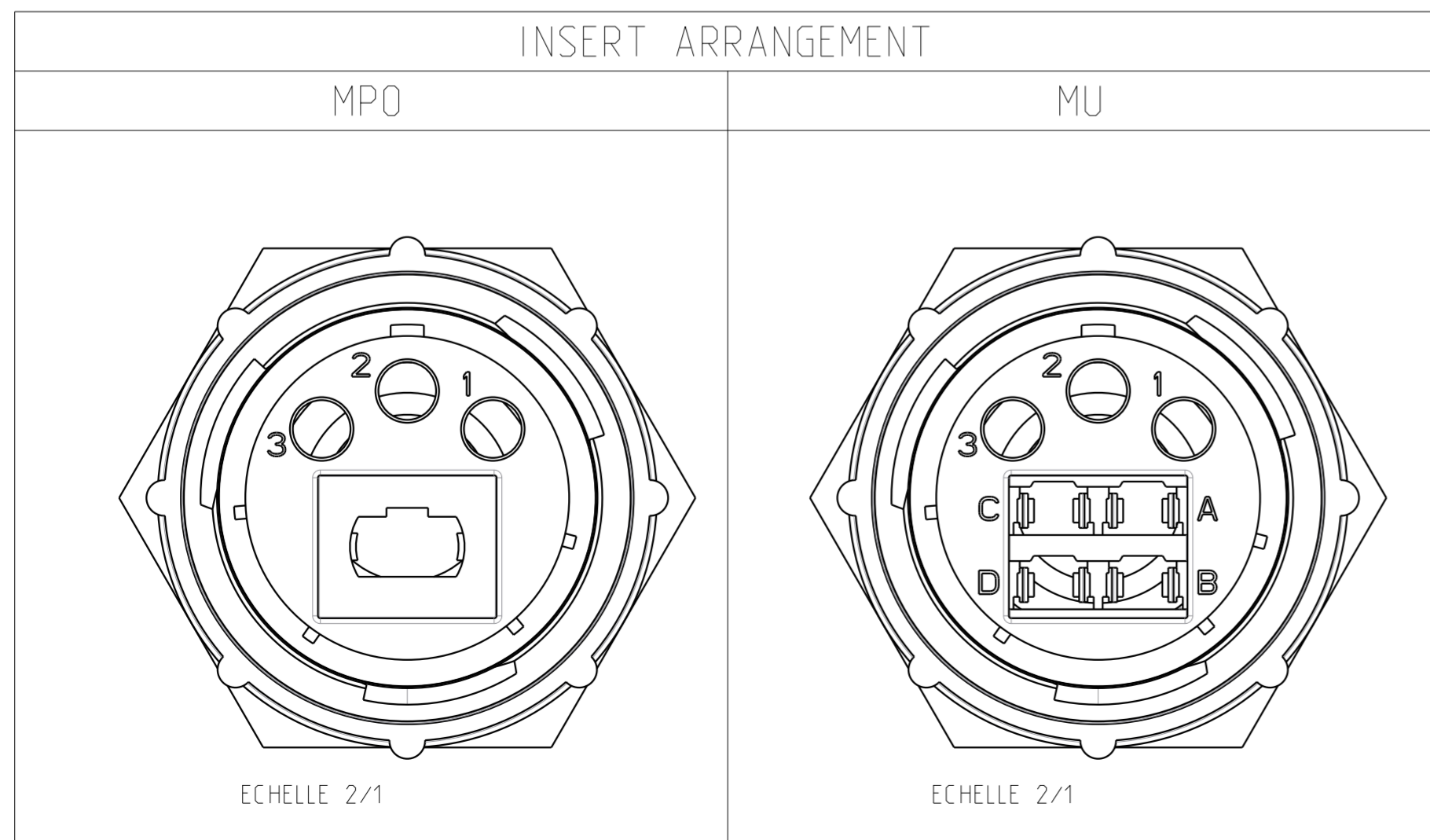

P/N		UTS6JC20HYBxxNx	
A	30/09/15	Creation	--
ISS	DATE	Latest modification - by:	FOUQUERAY
DESIGNED BY:	FOUQUERAY	DATE:	05/08/15
CHECKED BY:	SEE DISTRIBUTION LIST	DATE:	SEE DISTRIBUTION LIST
TITLE		plug with backshell - size 20 HYBRID connector	
SCALE	General angular 1/1	TOLERANCES	± 1°
MATERIAL		--	
General Linear Tolerances : ± 0.1		General machining surface texture Ra 1,6	Geometrical Tolerances See NF EN ISO 1101
PROJECT IC134411		This document is the property of SOURIAU It must not be reproduced or communicated without permission	
FORMAT	A2	DRAWING REFERENCE	UTS6JC20HYBXXNX-C01
SHEET		1 / 1	