



Chip Beads

For general signal line

GHz noise countermeasure (general signal line, high-speed signal line)

MMZ-E series

MMZ0603-E **0603[0201 inch]***

MMZ1005-E **1005[0402 inch]**

* Dimensions Code JIS[EIA]

REMINDERS FOR USING THESE PRODUCTS

Before using these products, be sure to request the delivery specifications.

SAFETY REMINDERS

Please pay sufficient attention to the warnings for safe designing when using these products.

REMINDERS

- The storage period is less than 12 months. Be sure to follow the storage conditions (Temperature: 5 to 40°C, Humidity: 10 to 75% RH or less).
If the storage period elapses, the soldering of the terminal electrodes may deteriorate.
- Do not use or store in locations where there are conditions such as gas corrosion (salt, acid, alkali, etc.).
- Before soldering, be sure to preheat components.
The preheating temperature should be set so that the temperature difference between the solder temperature and chip temperature does not exceed 150°C.
- Soldering corrections after mounting should be within the range of the conditions determined in the specifications.
If overheated, a short circuit, performance deterioration, or lifespan shortening may occur.
- When embedding a printed circuit board where a chip is mounted to a set, be sure that residual stress is not given to the chip due to the overall distortion of the printed circuit board and partial distortion such as at screw tightening portions.
- Self heating (temperature increase) occurs when the power is turned ON, so the tolerance should be sufficient for the set thermal design.
- Carefully lay out the coil for the circuit board design of the non-magnetic shield type.
A malfunction may occur due to magnetic interference.
- Use a wrist band to discharge static electricity in your body through the grounding wire.
- Do not expose the products to magnets or magnetic fields.
- Do not use for a purpose outside of the contents regulated in the delivery specifications.
- The products listed on this catalog are intended for use in general electronic equipment (AV equipment, telecommunications equipment, home appliances, amusement equipment, computer equipment, personal equipment, office equipment, measurement equipment, industrial robots) under a normal operation and use condition.
The products are not designed or warranted to meet the requirements of the applications listed below, whose performance and/or quality require a more stringent level of safety or reliability, or whose failure, malfunction or trouble could cause serious damage to society, person or property.
If you intend to use the products in the applications listed below or if you have special requirements exceeding the range or conditions set forth in the each catalog, please contact us.

- (1) Aerospace/Aviation equipment
- (2) Transportation equipment (cars, electric trains, ships, etc.)
- (3) Medical equipment
- (4) Power-generation control equipment
- (5) Atomic energy-related equipment
- (6) Seabed equipment
- (7) Transportation control equipment

- (8) Public information-processing equipment
- (9) Military equipment
- (10) Electric heating apparatus, burning equipment
- (11) Disaster prevention/crime prevention equipment
- (12) Safety equipment
- (13) Other applications that are not considered general-purpose applications

When designing your equipment even for general-purpose applications, you are kindly requested to take into consideration securing protection circuit/device or providing backup circuits in your equipment.

Chip Beads

Product compatible with RoHS directive

Halogen-free

Compatible with lead-free solders

For general signal line

GHz noise countermeasure (general signal line, high-speed signal line)

Overview of the MMZ-E Series

FEATURES

- Noise reduction solution for general signal line.
- Compared to the MMZ Series, it is a product that increases the SRF to GHz bands and can countermeasure noise at wide frequencies with 1 element.
- Compared to the MMZ Series, it can attain high impedance at GHz bands.
- Lineup includes 2 sizes: 0603 and 1005.
- Various frequency characteristics with 4 materials of different features for countermeasures against everything from general signals to high-speed signals.

APPLICATION

- Noise removal for mobile devices such as smartphones and tablet terminals, and various modules.
- Noise removal for PCs and recorders, household appliances such as STBs, smart grids, and industrial equipment.

PART NUMBER CONSTRUCTION

MMZ	0603		S	601		E	T		000
Series name	LxWxT Dimensions (mm)		Material name	Impedance (Ω) at 100MHz		Characteristic type	Packaging style		Internal code
	0603	0.6x0.3x0.3	S	601	600	E	T	Taping	000
	1005	1.0x0.5x0.5	A	102	1000				
			D						
			F						

OPERATING TEMPERATURE RANGE, PACKAGE QUANTITY, PRODUCT WEIGHT

Type	Temperature range		Package quantity	Individual weight
	Operating temperature	Storage temperature*		
	(°C)	(°C)	(pieces/reel)	(mg)
MMZ0603-E	-55 to +125	-55 to +125	15,000	0.3
MMZ1005-E	-55 to +125	-55 to +125	10,000	1

* The Storage temperature range is for after the circuit board is mounted.

- RoHS Directive Compliant Product: See the following for more details related to RoHS Directive compliant products. <http://product.tdk.com/en/environment/rohs/>
- Halogen-free: Indicates that Cl content is less than 900ppm, Br content is less than 900ppm, and that the total Cl and Br content is less than 1500ppm.

• All specifications are subject to change without notice.

Overview of the MMZ-E Series

RECOMMENDED REFLOW PROFILE



Preheating			Soldering		Peak	
Temp.	Temp.	Time	Temp.	Time	Temp.	Time
T1	T2	t1	T3	t2	T4	t3
150°C	180°C	60 to 120s	230°C	30 to 60s	250 to 260°C	10s

MMZ-E series

MMZ0603-E Type



■ SHAPE & DIMENSIONS

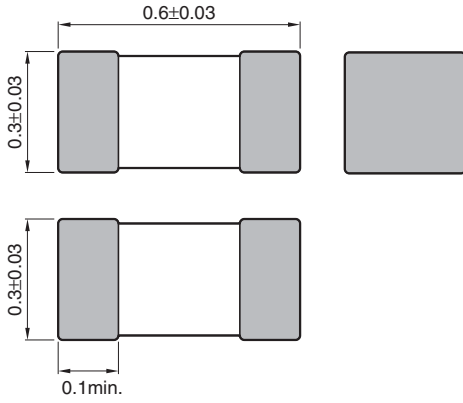

Dimensions in mm

■ RECOMMENDED LAND PATTERN

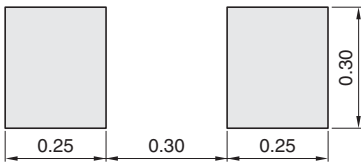

Dimensions in mm

• All specifications are subject to change without notice.

MMZ-E series MMZ0603-E Type

■ ELECTRICAL CHARACTERISTICS

□ CHARACTERISTICS SPECIFICATION TABLE

Impedance				DC resistance (Ω)max.	Rated current (mA)max.	Part No.
[100MHz] (Ω)	Tolerance	[1GHz] (Ω)	Tolerance			
120	$\pm 25\%$	200	$\pm 40\%$	0.37	250	MMZ0603S121ET000
240	$\pm 25\%$	400	$\pm 40\%$	0.71	200	MMZ0603S241ET000
600	$\pm 25\%$	1000	$\pm 40\%$	1.60	150	MMZ0603S601ET000
1000	$\pm 25\%$	1800	$\pm 40\%$	2.60	125	MMZ0603S102ET000
120	$\pm 25\%$	300	$\pm 40\%$	0.44	250	MMZ0603A121ET000
240	$\pm 25\%$	600	$\pm 40\%$	0.86	200	MMZ0603A241ET000
33	$\pm 25\%$	200	$\pm 40\%$	0.6	250	MMZ0603D330ET000
47	$\pm 25\%$	300	$\pm 40\%$	0.76	200	MMZ0603D470ET000
120	$\pm 25\%$	1000	$\pm 40\%$	2.4	125	MMZ0603D121ET000
56	$\pm 25\%$	700	$\pm 40\%$	1.9	150	MMZ0603F560ET000
75	$\pm 25\%$	950	$\pm 40\%$	2.6	125	MMZ0603F750ET000

○ Measurement equipment

Measurement item	Product No.	Manufacturer
Impedance	E4991A+16197	Agilent Technologies
DC resistance	Type-7556	Yokogawa

* Equivalent measurement equipment may be used.

MMZ-E series MMZ0603-E Type

ELECTRICAL CHARACTERISTICS

Z VS. FREQUENCY CHARACTERISTICS (BY SERIES)

MMZ0603S-E SERIES

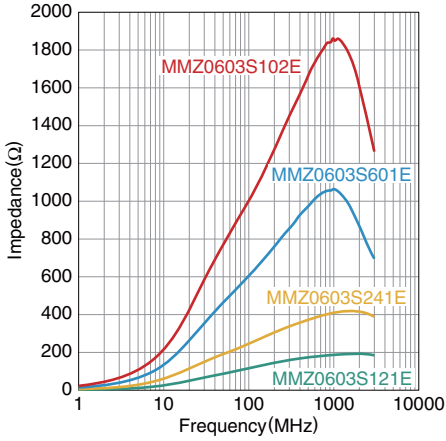

MMZ0603A-E SERIES

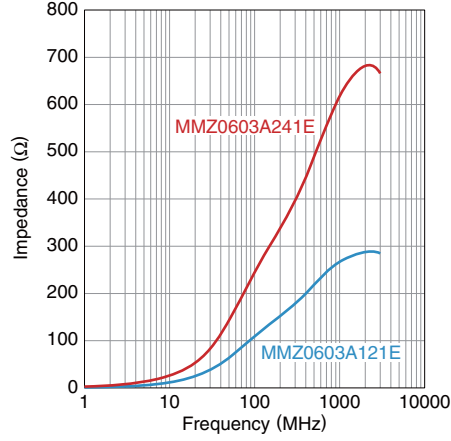

MMZ0603D-E SERIES

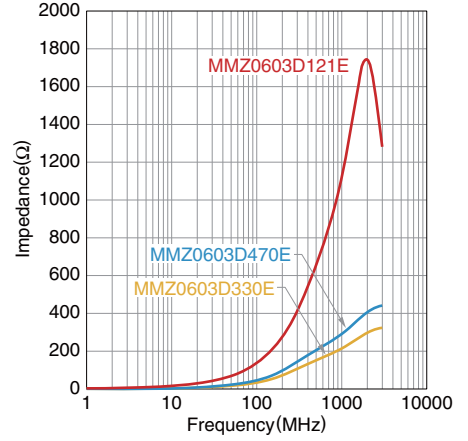

MMZ0603F-E SERIES

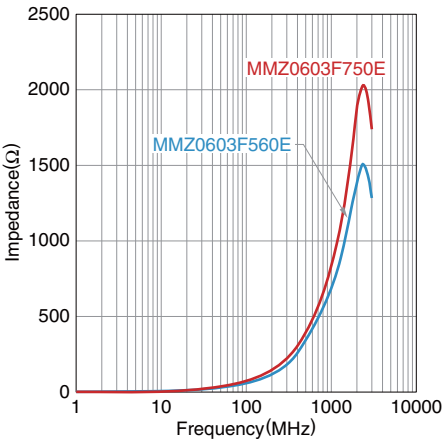

• All specifications are subject to change without notice.

MMZ-E series MMZ0603-E Type

ELECTRICAL CHARACTERISTICS

Z, X, R VS. FREQUENCY CHARACTERISTICS

MMZ0603S121ET000

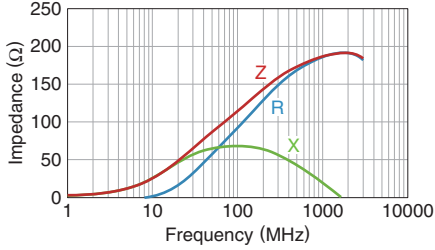

MMZ0603S241ET000

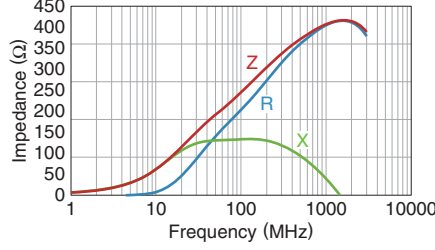

MMZ0603S601ET000

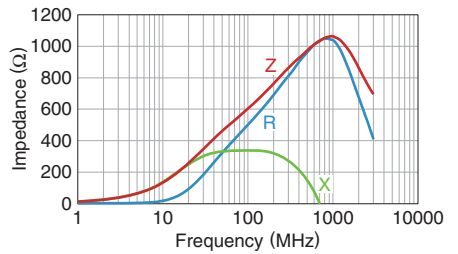

MMZ0603S102ET000

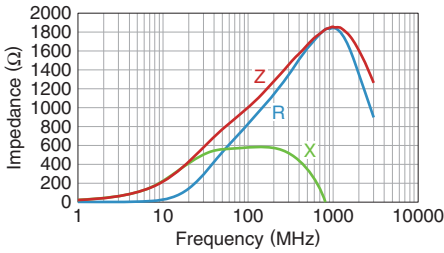

MMZ0603A121ET000

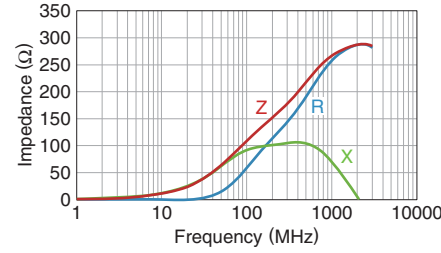

MMZ0603A241ET000

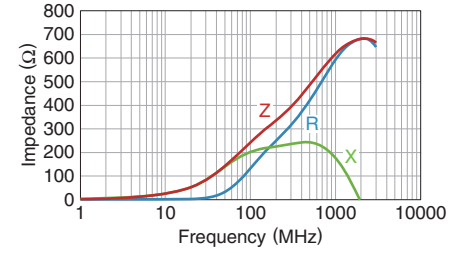

MMZ0603D330ET000

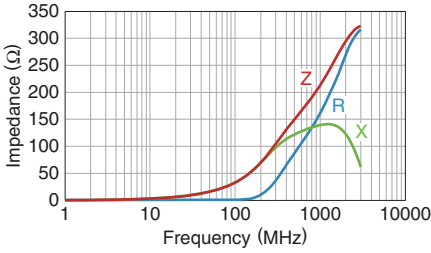

MMZ0603D470ET000

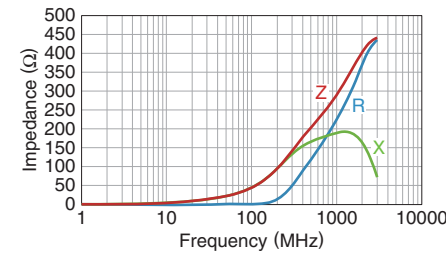

MMZ0603D121ET000

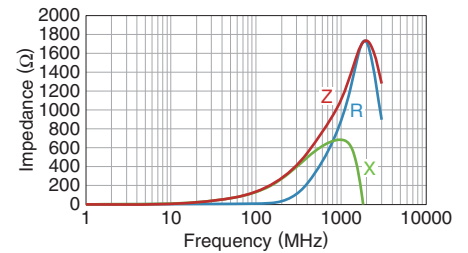

MMZ0603F560ET000

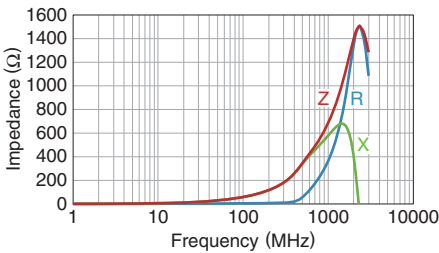

MMZ0603F750ET000

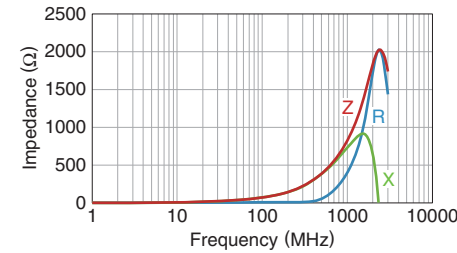

• All specifications are subject to change without notice.

MMZ-E series

MMZ1005-E Type



SHAPE & DIMENSIONS

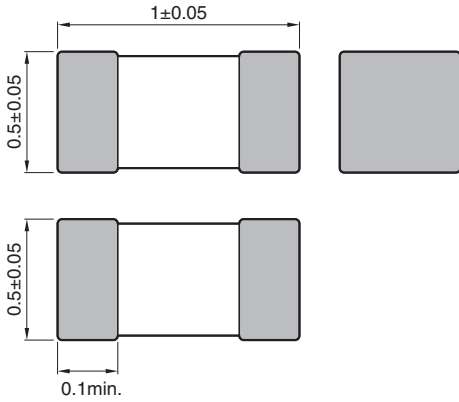

Dimensions in mm

RECOMMENDED LAND PATTERN

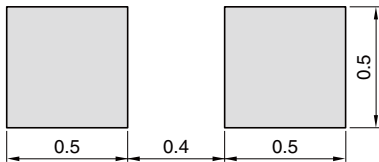

Dimensions in mm

• All specifications are subject to change without notice.

MMZ-E series MMZ1005-E Type

■ ELECTRICAL CHARACTERISTICS

□ CHARACTERISTICS SPECIFICATION TABLE

Impedance				DC resistance (Ω)max.	Rated current (mA)max.	Part No.
[100MHz]		[1GHz]				
(Ω)	Tolerance	(Ω)	Tolerance			
600	±25%	1000	±40%	0.65	300	MMZ1005S601ET000
1000	±25%	1400	±40%	1.00	250	MMZ1005S102ET000
1800	±25%	1800	±40%	1.50	200	MMZ1005S182ET000
600	±25%	1400	±40%	0.80	300	MMZ1005A601ET000
1000	±25%	2000	±40%	1.20	250	MMZ1005A102ET000
1500	±25%	2300	±40%	1.60	230	MMZ1005A152ET000
1800	±25%	2700	±40%	2.10	200	MMZ1005A182ET000
2200	±25%	3000	±40%	2.20	150	MMZ1005A222ET000
120	±25%	1000	±40%	0.70	300	MMZ1005D121ET000
220	±25%	1700	±40%	1.00	250	MMZ1005D221ET000
47	±25%	800	±40%	0.70	300	MMZ1005F470ET000
75	±25%	1500	±40%	1.00	250	MMZ1005F750ET000
120	±25%	2300	±40%	1.50	200	MMZ1005F121ET000

○ Measurement equipment

Measurement item	Product No.	Manufacturer
Impedance	E4991A+16192A	Agilent Technologies
DC resistance	Type-7556	Yokogawa

* Equivalent measurement equipment may be used.

MMZ-E series **MMZ1005-E Type**

■ ELECTRICAL CHARACTERISTICS

□ Z VS. FREQUENCY CHARACTERISTICS (BY SERIES)

MMZ1005S-E SERIES

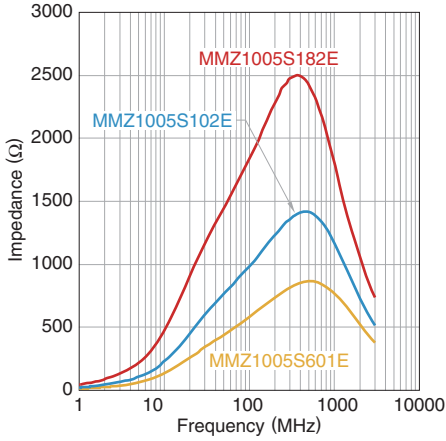

MMZ1005A-E SERIES

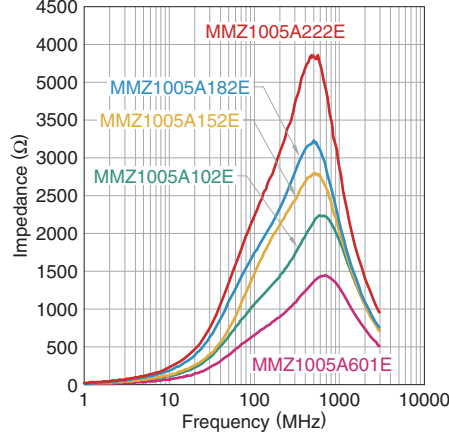

MMZ1005D-E SERIES

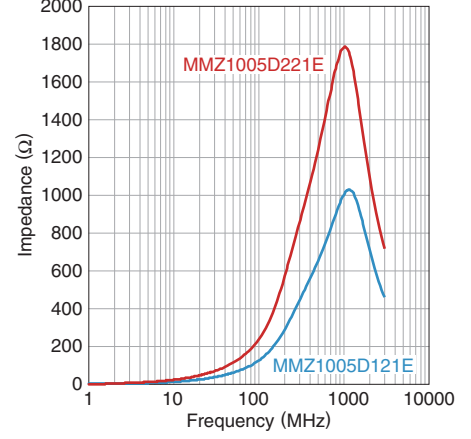

MMZ1005F-E SERIES

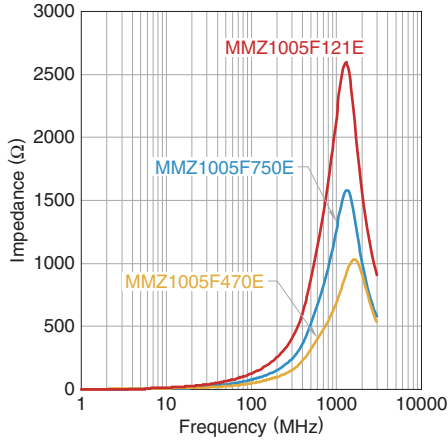

• All specifications are subject to change without notice.

MMZ-E series **MMZ1005-E Type**

ELECTRICAL CHARACTERISTICS

Z, X, R VS. FREQUENCY CHARACTERISTICS

MMZ1005S601ET000

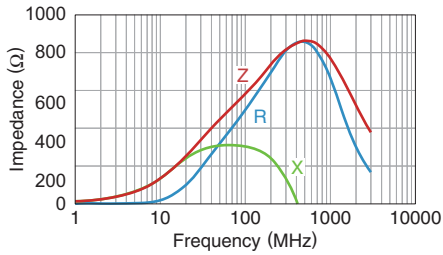

MMZ1005S102ET000

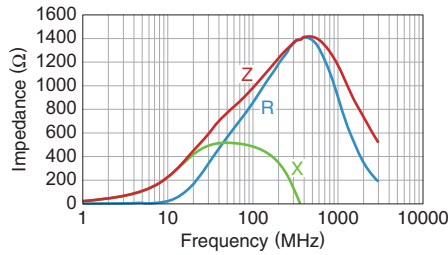

MMZ1005S182ET000

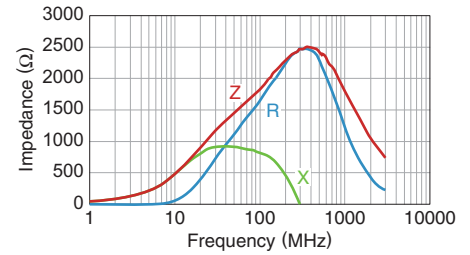

MMZ1005A601ET000

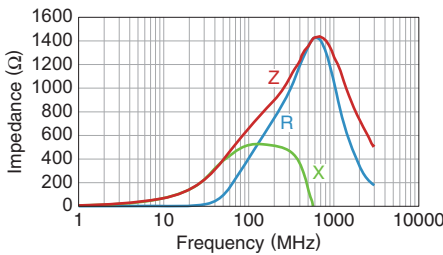

MMZ1005A102ET000

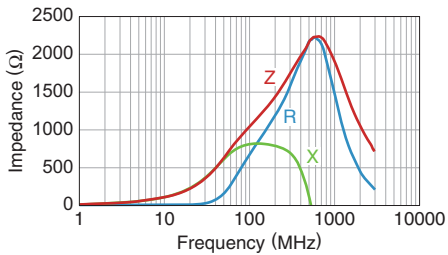

MMZ1005A152ET000

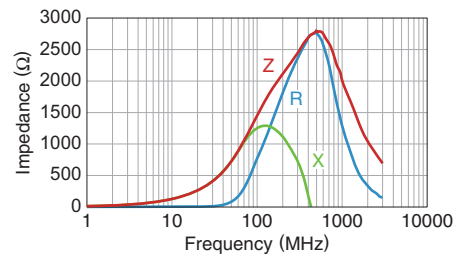

MMZ1005A182ET000

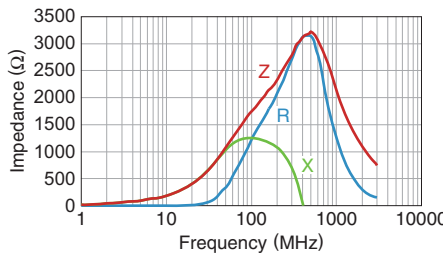

MMZ1005A222ET000

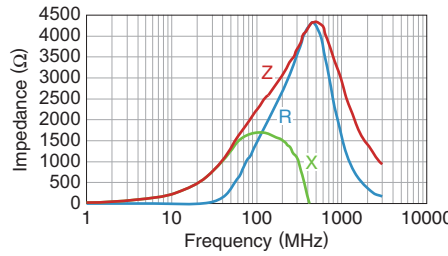

MMZ1005D121ET000

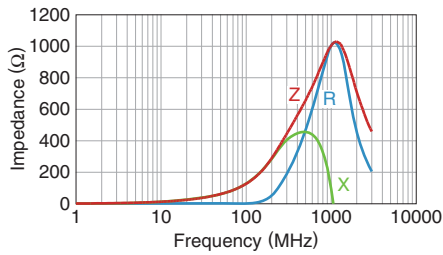

MMZ1005D221ET000

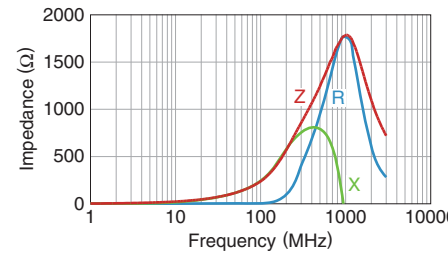

MMZ1005F470ET000

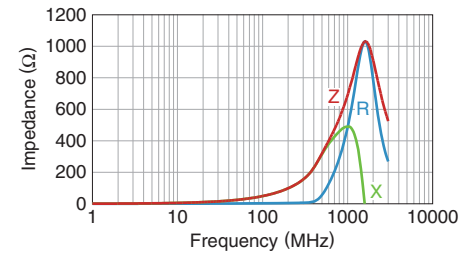

MMZ1005F750ET000

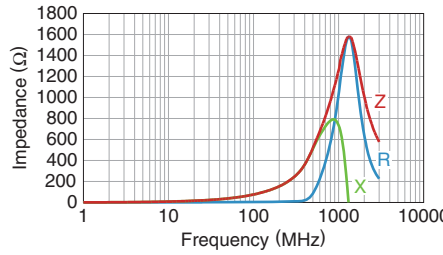

MMZ1005F121ET000

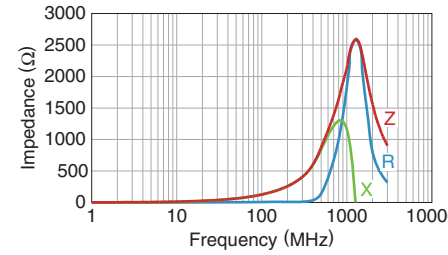

• All specifications are subject to change without notice.

MMZ-E series

Packaging style

REEL DIMENSIONS

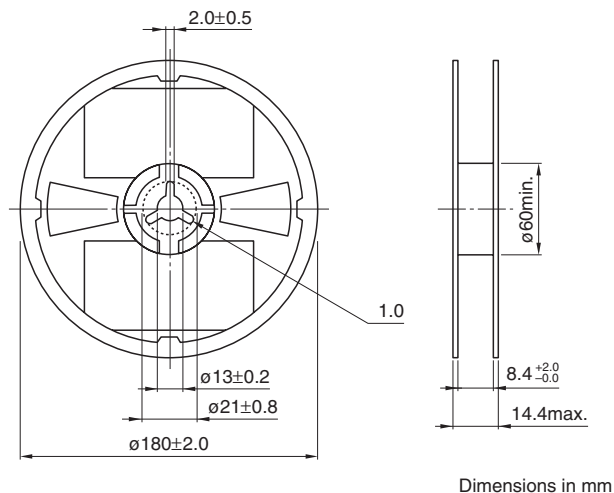

Dimensions in mm

TAPE DIMENSIONS

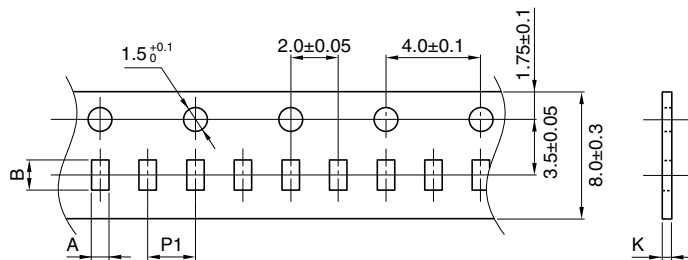

Dimensions in mm

Type	A	B	P1	K
MMZ0603-E	0.38±0.05	0.68±0.05	2.0±0.05	0.5max.
MMZ1005-E	0.65±0.1	1.15±0.1	2.0±0.05	0.8max.

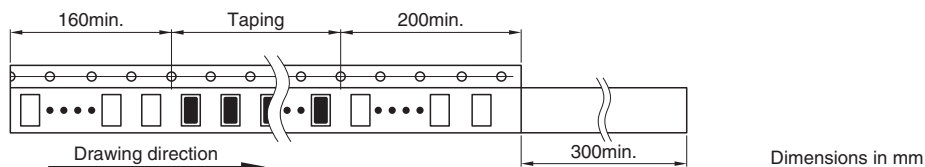

Dimensions in mm

• All specifications are subject to change without notice.